

MULTI-NETWORK CABLE TESTER KIT

MODEL TCT-255K



Assembly and Instruction Manual



Elenco Electronics, Inc.

INTRODUCTION

The TCT-255 Cable Tester is a convenient instrument for testing different unshielded wiring schemed communication cable with RJ-11 and RJ-45 connectors and coax cable. This tester can be used for testing cables before and/or after they are installed. The tester offers easy operation by having to push only one button. Testing status is indicated by multiple LEDs and an auto power-off function maximizes battery life.

The unique design of the TCT-255 allows you to place the parts over their corresponding symbol in the schematic drawing on the surface of the PC board during assembly. This technique maximizes the learning process while keeping the chances of an assembly error at a minimum. It is very

important, however, that good soldering practices are used to prevent bad connections.

The actual assembly is broken into **SEVEN SECTIONS**. After each assembly, you will be instructed to make certain tests and measurements to prove that each section is functioning properly. The theory for each section, or stage, should be read before the test is started. This will provide the student with an understanding of what that stage has been designed to accomplish, and how it actually works. If a test fails to produce the proper results, a troubleshooting guide is provided to help you correct the problem. For testing you need to have only a voltmeter for measuring DC and AC.

GENERAL DISCUSSION

You can see a block diagram of the TCT-255 in Figure 1 below.

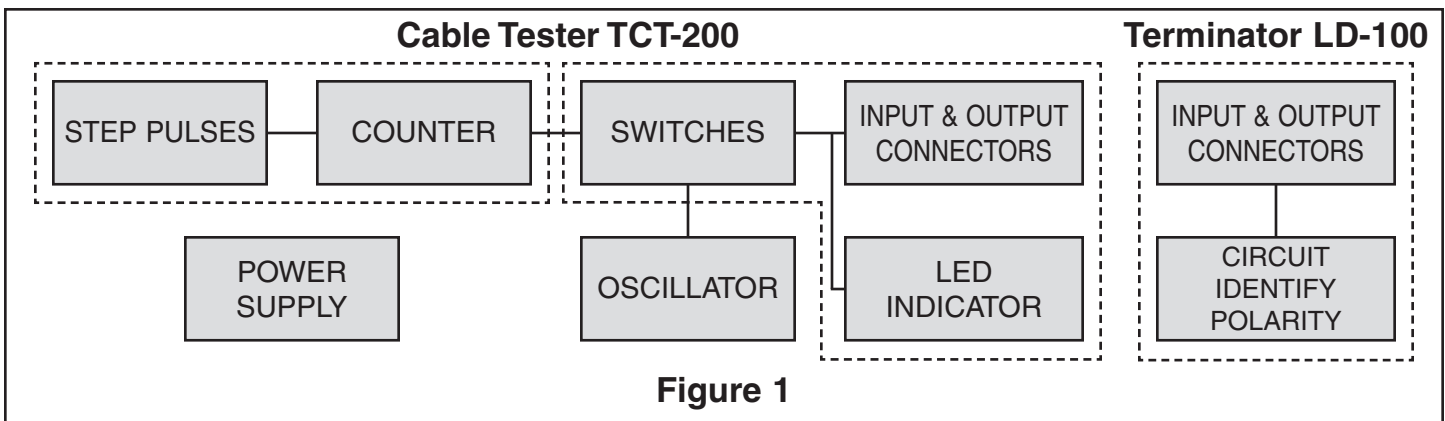

Figure 1

The TCT-255 Cable Tester has five basic blocks:

1. Power Supply

It powers all of the circuits of the tester (not including the terminator). The power supply has a low battery indicator (less than 7.5V) and a circuit to disconnect power 30 - 50 seconds after the last push on the test switch.

2. Oscillator

Uses a 555 timer IC with two resistors and one capacitor. They control the free running frequency and duty cycle.

3. Step Pulses with Counter

The outputs change by the positive pulses from the test button switch.

4. Switches and LED Indicator

It includes eight electronic switches for operating the indicators (16 LEDs).

5. Terminator

Connected to cable under test. Identifies the polarity signals.

IDENTIFYING RESISTOR VALUES

Use the following information as a guide in properly identifying the value of resistors.

BAND 1 1st Digit		BAND 2 2nd Digit		Multiplier		Resistance Tolerance	
Color	Digit	Color	Digit	Color	Multiplier	Color	Tolerance
Black	0	Black	0	Black	1	Silver	+10%
Brown	1	Brown	1	Brown	10	Gold	+5%
Red	2	Red	2	Red	100	Brown	+1%
Orange	3	Orange	3	Orange	1,000	Red	+2%
Yellow	4	Yellow	4	Yellow	10,000	Orange	+3%
Green	5	Green	5	Green	100,000	Green	+5%
Blue	6	Blue	6	Blue	1,000,000	Blue	+25%
Violet	7	Violet	7	Silver	0.01	Violet	+1%
Gray	8	Gray	8	Gold	0.1		
White	9	White	9				

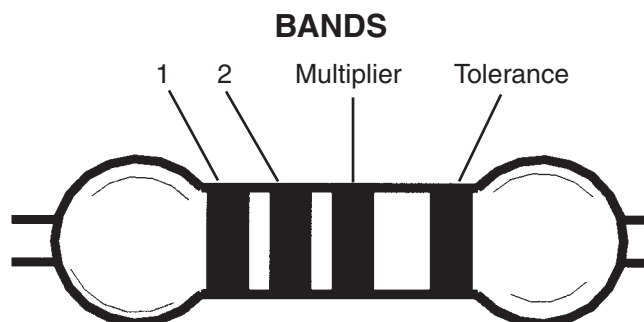

IDENTIFYING CAPACITOR VALUES

Capacitors will be identified by their capacitance value in pF (picofarads), nF (nanofarads), or μ F (microfarads). Most capacitors will have their actual value printed on them. Some capacitors may have their value printed in the following manner. The maximum operating voltage may also be printed on the capacitor.

Multiplier	For the No.	0	1	2	3	4	5	8	9
		Multiply By	1	10	100	1k	10k	100k	.01

Note: The letter "R" may be used at times to signify a decimal point; as in 3R3 = 3.3

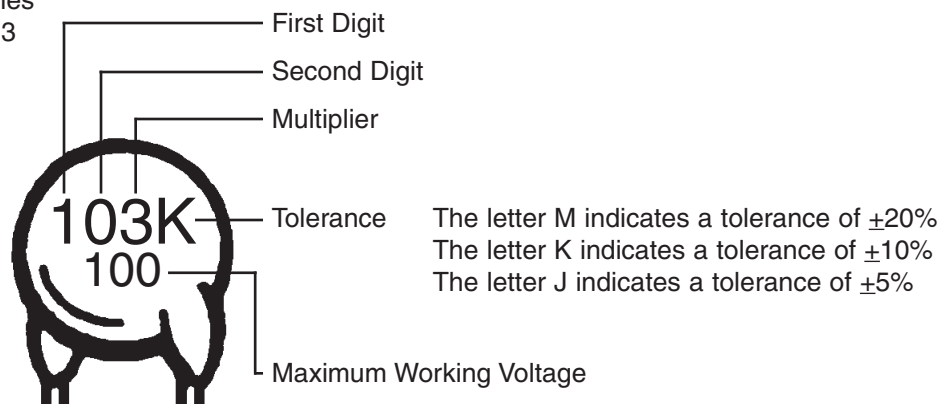

The value is $10 \times 1,000 = 10,000\text{pF}$ or $.01\mu\text{F}$ 100V

CONSTRUCTION

Introduction

Assembly of your TCT-255 Multi-Network Cable Tester Kit will prove to be an exciting project and give you much satisfaction and personal achievement. If you have experience in soldering and wiring techniques, then you should have no problem with the assembly of this kit. Care must be given to identifying the proper components and in good soldering habits. Above all, take your time and follow these easy step-by-step instructions. Remember, "An ounce of prevention is worth a pound of cure". Avoid making mistakes and no problems will occur.

Safety Procedures

- Wear eye protection when soldering.
- Locate soldering iron in an area where you do not have to go around it or reach over it.
- Do not hold solder in your mouth. Solder contains lead and is a toxic substance. Wash your hands thoroughly after handling solder.
- Be sure that there is adequate ventilation present.

Assemble Components

In all of the following assembly steps, the components must be installed on the top side of the PC board unless otherwise indicated. The top legend shows where each component goes. The leads pass through the corresponding holes and the board is turned to solder the component leads on the foil side. Solder immediately unless the pad is adjacent to another hole which will interfere with the placement of the other component. Cut excessive leads with a diagonal cutter. Then, place a check mark in the box provided next to each step to indicate that the step is completed. Be sure to save the extra leads for use as jumper wires if needed.



- Rx - 100Ω 5% 1/4W Resistor
(brown-black-brown-gold)

Soldering

The most important factor in assembling your cable tester kit is good soldering techniques. Using the proper soldering iron is of prime importance. A small pencil type soldering iron of 25 - 40 watts is recommended. **The tip of the iron must be kept clean at all times and well tinned.** Many areas on the PC board are close together and care must be given not to form solder shorts. Size and care of the tip will eliminate problems.

For a good soldering job, the areas being soldered must be heated sufficiently so that the solder flows freely. Apply the solder simultaneously to the component lead and the component pad on the PC board so that good solder flow will occur. Be sure that the lead extends through the solder smoothly indicating a good solder joint. **Use only rosin core solder of 63/37 or 60/40 alloy.**

DO NOT USE ACID CORE SOLDER! Do not blob the solder over the lead because this can result in a cold solder joint.

Heat Sinking

Electronic components such as transistors, IC's, and diodes can be damaged by the heat during soldering. Heat sinking is a way of reducing the heat on the components while soldering. Dissipating the heat can be achieved by using long nose pliers, an alligator clip, or a special heat dissipating clip. The heat sink should be held on the component lead between the part and the solder joint.

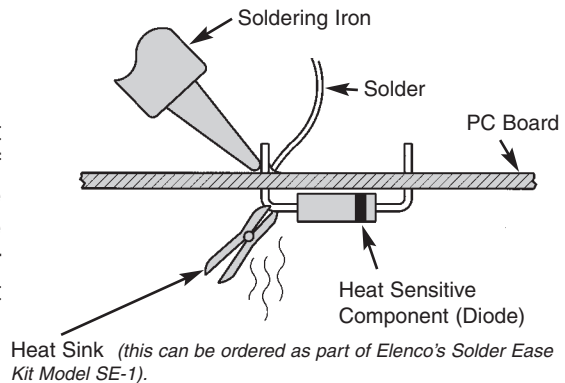

Figure 6

A poorly soldered joint can greatly affect small current flow in circuits and can cause equipment failure. You can damage a PC board or a component with too much heat or cause a cold solder joint with insufficient heat. Sloppy soldering can cause bridges between two adjacent foils preventing the circuit from functioning.

What Good Soldering Looks Like

A good solder connection should be bright, shiny, smooth, and uniformly flowed over all surfaces.

Soldering a PC board

1. Solder all components from the copper foil side only. Push the soldering iron tip against both the lead and the circuit board foil.
2. Apply a small amount of solder to the iron tip. This allows the heat to leave the iron and onto the foil. Immediately apply solder to the opposite side of the connection, away from the iron. Allow the heated component and the circuit foil to melt the solder.
3. Allow the solder to flow around the connection. Then, remove the solder and the iron and let the connection cool. The solder should have flowed smoothly and not lump around the wire lead.
4. Here is what a good solder connection looks like.

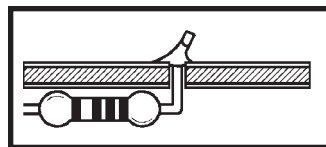
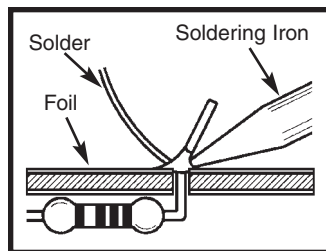
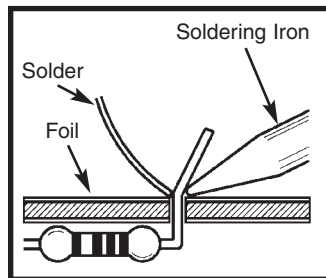
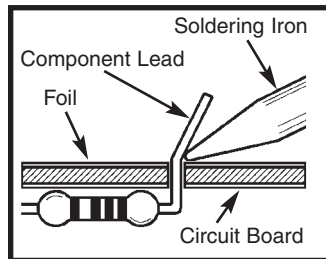

Types of Poor Soldering Connections

1. **Insufficient heat** - the solder will not flow onto the lead as shown.
2. **Insufficient solder** - let the solder flow over the connection until it is covered. Use just enough solder to cover the connection.
3. **Excessive solder** - could make connections that you did not intend to between adjacent foil areas or terminals.
4. **Solder bridges** - occur when solder runs between circuit paths and creates a short circuit. This is usually caused by using too much solder. To correct this, simply drag your soldering iron across the solder bridge as shown.

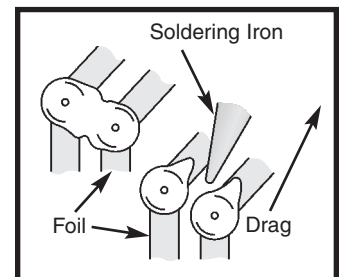
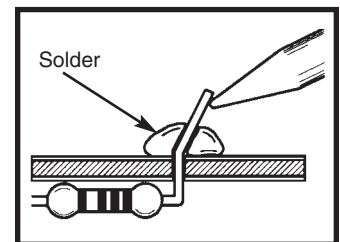
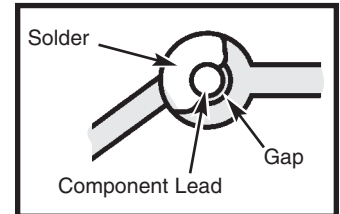
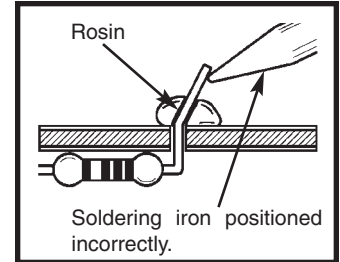

TROUBLESHOOTING

1. One of the most frequently occurring problems is poor solder connections.
 - a) Tug slightly on all parts to make sure that they are indeed soldered.
 - b) All solder connections should be shiny. Resolder any that are not.
 - c) Solder should flow into a smooth puddle rather than a round ball. Resolder any connection that has formed into a ball.
 - d) Have any solder bridges formed? A solder bridge may occur if you accidentally touch an adjacent foil by using too much solder or by dragging the soldering iron across adjacent foils. Break the bridge with your soldering iron.

SECTION A

Power Supply

PARTS LIST - SECTION A

RESISTORS

Qty.	Symbol	Description	Color Code	Part #
□ 2	R12, R17	1kΩ 5% 1/4W	brown-black-red-gold	141000
□ 1	R16	5.6kΩ 5% 1/4W	green-blue-red-gold	145600
□ 1	R15	12kΩ 5% 1/4W	brown-red-orange-gold	151200
□ 1	R9	3.3MΩ 5% 1/4W	orange-orange-green-gold	173300

CAPACITORS

Qty.	Symbol	Value	Description	Part #
□ 1	C2	22μF	Electrolytic Radial	272244

SEMICONDUCTORS

Qty.	Symbol	Value	Description	Part #
□ 1	D17	1N4001	Silicon Diode	314001
□ 1*		1N4736	Zener Diode 6.8V 1W	314736
□ 1	D18	1N5235	Zener Diode 6.8V 0.5W	315235
□ 2	Q2, Q3	2N3904	Transistor NPN	323904
□ 1	Q1	2N3906	Transistor PNP	323906
□ 1	D19		LED Red	350003
□ 1	U4	40106	Integrated Circuit (IC) Hex Inverter	330106

MISCELLANEOUS

Qty.	Symbol	Description	Part #
□ 1		PC Board Tester TCT-200	517041
□ 1	SW1	Switch Push Button DPDT	540203
□ 1		Battery 9V	590009
□ 1		Battery Snap 9V	590098
□ 1		Spacer	624018
□ 1	U4	Socket IC 14-pin	664014
□ 1		Tubing #20 1/2"	890020
□ 1		Solder	9ST4

* Packaged in a separate bag, used for testing only.

PARTS IDENTIFICATION

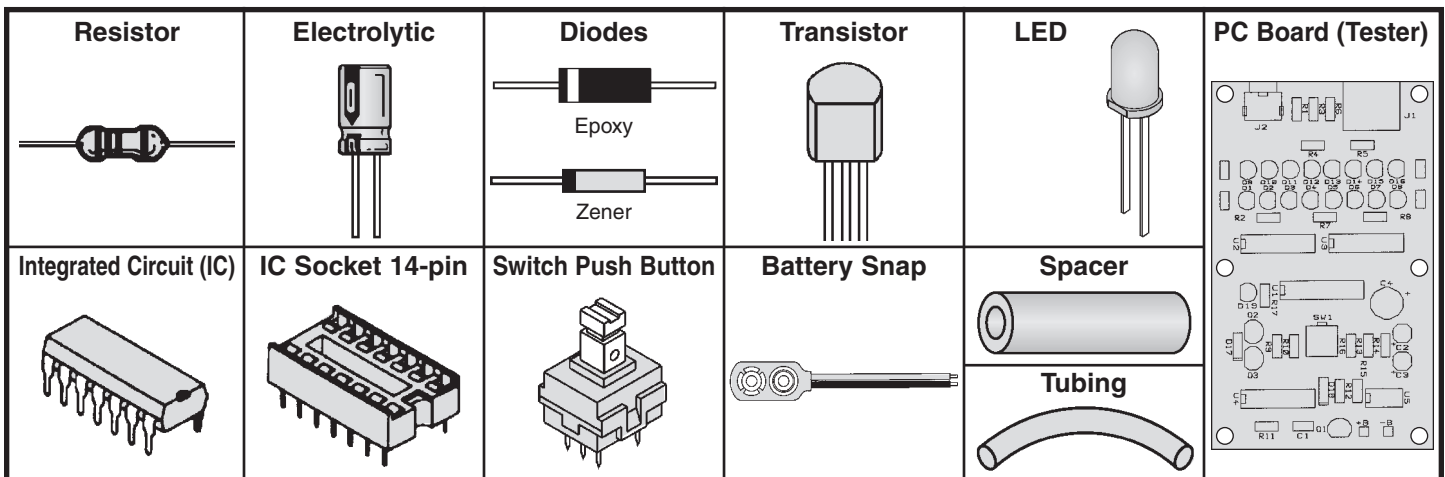

ASSEMBLE THE FOLLOWING COMPONENTS TO THE PC BOARD

In all of the following steps the components must be installed on the top legend side of the PC board. The board is turned to solder the component leads on the foil side.

- R17 - 1kΩ 5% 1/4W Resistor (brown-black-red-gold) (see Figure A)
- D19 - LED Red
 Tubing
 Spacer (see Figure B)
- R9 - 3.3MΩ 5% 1/4W Resistor (orange-orange-green-gold) (see Figure A)
- Q2 - 2N3904 Transistor NPN (see Figure C)
- D17 - 1N4001 Diode (epoxy) (see Figure D)
- Q3 - 2N3904 Transistor NPN (see Figure C)
- U4 - 14-pin IC Socket
 U4 - 40106 IC Hex Inverter (see Figure E)

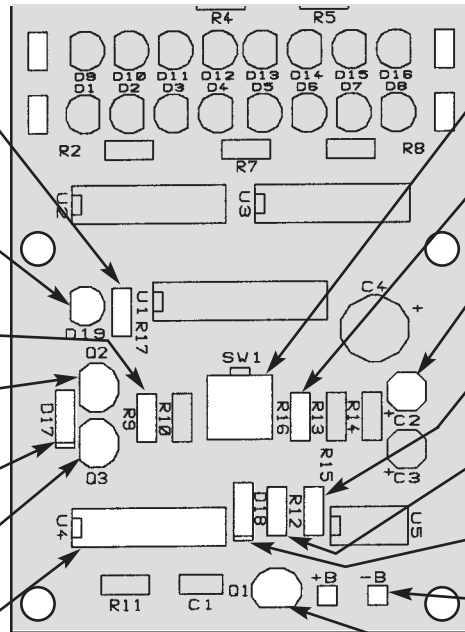

- SW1 - Push Button Switch (see Figure F)
- R16 - 5.6kΩ 5% 1/4W Resistor (green-blue-red-gold) (see Figure A)
- C2 - 22μF Electrolytic (see Figure G)
- R15 - 12kΩ 5% 1/4W Resistor (brown-red-orange-gold) (see Figure A)
- R12 - 1kΩ 5% 1/4W Resistor (brown-black-red-gold) (see Figure A)
- D18 - 1N5235 Zener Diode 0.5W (see Figure D)
- Battery Snap (see Figure H)
- Q1 - 2N3906 Transistor PNP (see Figure C)

Figure A

Mount the resistor flat against the PC board as shown.

Figure B

Mount the LED with the tubing and plastic spacer to the PC board as shown. Note the flat side of the LED and the PC board marking.

Figure C

Mount the transistor to the PC board noting the flat side.

Figure D

Diodes have polarity. Mount the diodes in the direction marked on the PC board as shown.

Figure E

Insert the IC socket into the PC board with the notch in the direction shown on the top legend. Solder the IC socket into place. Insert the IC into the socket with the notch in the same direction as the notch on the socket.

Figure F

IMPORTANT!!! Mount the push button switch as shown. The circle **MUST** be facing the other direction from the marking "SW1" on the PC board.

Figure G

Electrolytic capacitors have polarity. Be sure to mount them with the negative (-) lead (marked on the side) in the correct hole.

Figure H

Mount the battery snap as shown. The black (-) lead goes to -B and the red (+) lead goes to +B.

SECTION A - POWER SUPPLY

When the SW1 (test button) is pushed, capacitor C2 (see schematic diagram, Figure 1) is charged to the battery voltage. Transistor Q1 turns on and all of the circuits in the tester are powered. If you don't push SW1, capacitor C2 begins discharging. When the voltage on C2 is less than 0.7V, transistor Q1 and the power turn off after 30-50 seconds.

When the voltage of the battery is less than 7.5V, transistors Q2 and Q3 turn on and LED D19 (Low Battery) lights. The diode D17 protects the tester from wrong polarity input voltage.

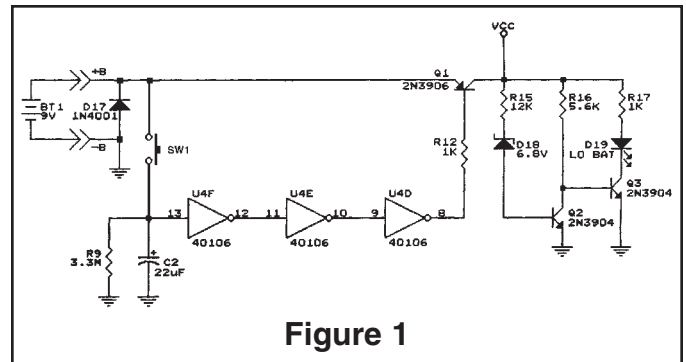

Figure 1

TESTING

- 1. Connect the battery to the battery snap.
- 2. Set the voltmeter to read 20VDC and connect the COM lead to the negative (-) side of the battery and the V lead to the positive (+) side of the battery as shown in Figure 2. The meter should indicate 9-10VDC. Push switch SW1.

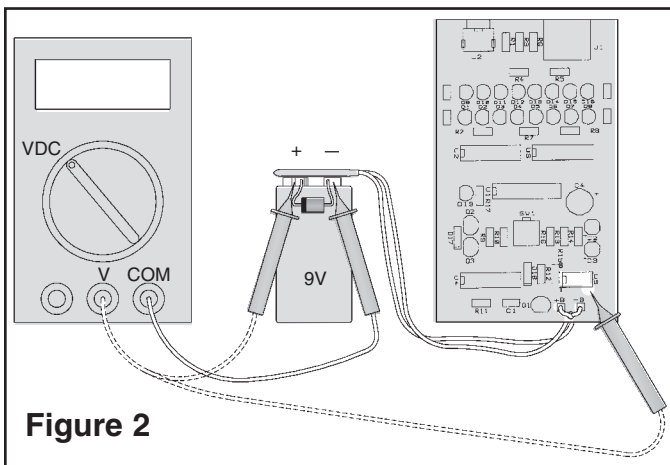

Figure 2

- 3. Remove the V lead from the positive (+) side of the battery and move to pad of pin 4 of IC U5. The meter should indicate the same voltage, but after 30-50 seconds, the voltage should drop to 0V.
- 4. Push the switch SW1 again. The meter should indicate the same voltage as in step 2. If not:
 - a) Check that the battery snap is connected with the the right polarity as shown in the assembly instructions.
 - b) Check that the transistor Q1 is 2N3906 and mounted with the emitter, base and collector leads as shown in the assembly instructions.

c) Check that R9, R12 and C2 are the correct values.

d) Check that D17, D18, C2, U4 and SW1 are installed as shown in the assembly instructions.

- 5. Bend the zener diode 1N4736 (6.8V 1W, located in a separate bag) as shown in Figure 3.

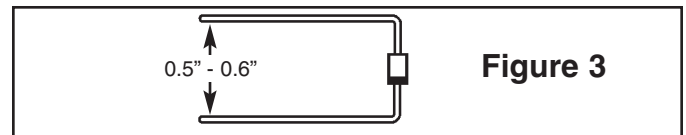

Figure 3

Push the switch SW1 again and short the battery by the zener diode for 1-2 seconds (the side with the band should be touching the "+" terminal of the battery, see Figure 2). LED D19 (Lo Batt.) should be lit. Remove the zener diode and the LED should turn off. If not:

- a) Check that the transistors Q2 and Q3 are 2N3904 and mounted as shown in the assembly instructions.
- b) Check zener diode D18 and LED D19. Be sure that they are installed as shown in the assembly instructions.
- c) Check that resistors R15, R16 and R17 are the correct values.

Remove the battery from the battery snap and the leads from the tester.

SECTION B

Oscillator

PARTS LIST - SECTION B

RESISTORS

Qty.	Symbol	Description	Color Code	Part #
□ 1	R13	18kΩ 5% 1/4W	brown-gray-orange-gold	151800
□ 1	R14	100kΩ 5% 1/4W	brown-black-yellow-gold	161000

CAPACITORS

Qty.	Symbol	Value	Description	Part #
□ 1	C3	1μF	Electrolytic Radial	261047

SEMICONDUCTORS

Qty.	Symbol	Value	Description	Part #
□ 1	U5	555	Integrated Circuit (IC) 555 Timer	330555

MISCELLANEOUS

Qty.	Symbol	Description	Part #
□ 1	U5	Socket IC 8-pin	664008

PARTS IDENTIFICATION

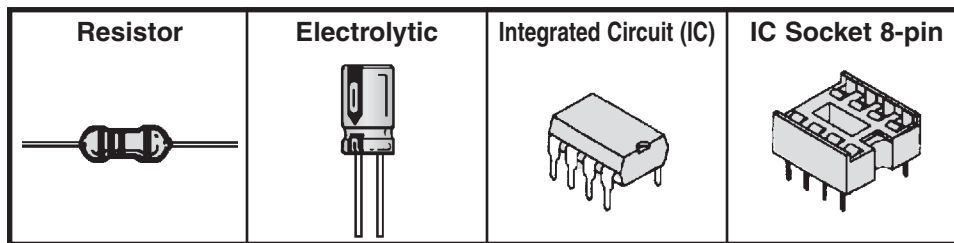

ASSEMBLE THE FOLLOWING COMPONENTS TO THE PC BOARD

In all of the following steps the components must be installed on the top legend side of the PC board. The board is turned to solder the component leads on the foil side.

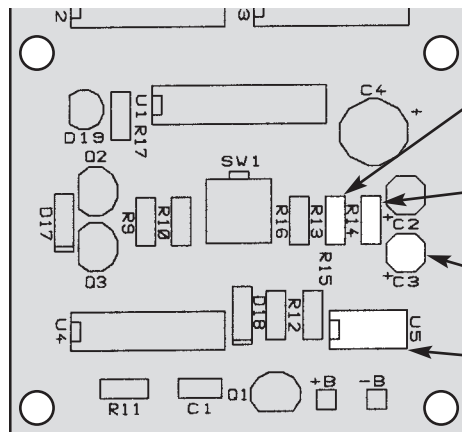
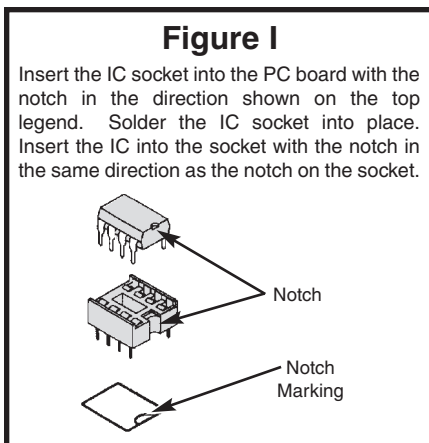

- R13 - 18kΩ 5% 1/4W Resistor (brown-gray-orange-gold) (see Figure A)
- R14 - 100kΩ 5% 1/4W Resistor (brown-black-yellow-gold) (see Figure A)
- C3 - 1μF Electrolytic Radial (see Figure G)
- U5 - 8-pin IC Socket
- U5 - 555 IC Timer (see Figure I)

SECTION B - OSCILLATOR

The oscillator section consists of a 555 timing circuit, resistors R13, R14, and capacitor C3. The 555 IC is configured as an astable or free-running oscillator. The values of the resistor R14 and capacitor C3 set the output frequency at 8Hz. The IC will produce a continuous 8Hz square wave from pin 3 as long as it is powered.

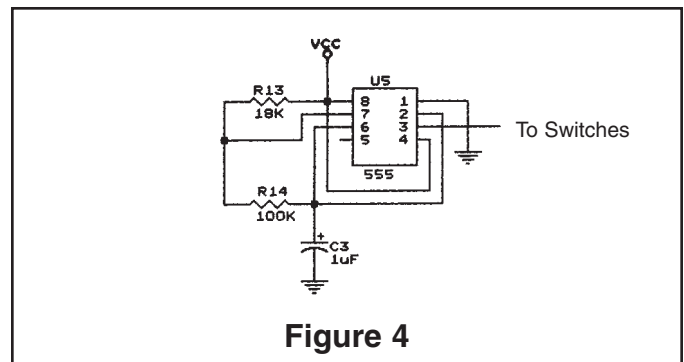

Figure 4

TESTING

- 1. Connect the battery to the battery snap.
- 2. Set the voltmeter to read 20VAC and connect the COM lead to the negative (-) side of the battery and the V lead to pad of pin 8 of IC U3 as shown in Figure 5. The meter should indicate 0V. Push switch SW1. The meter should indicate 3-5VAC. If not:
 - a) Check U5 and C3 to be sure that they are installed as shown in the assembly instructions.
 - b) Check R13 and R14 are the correct values.

Remove the battery from the battery snap and the leads from the tester.

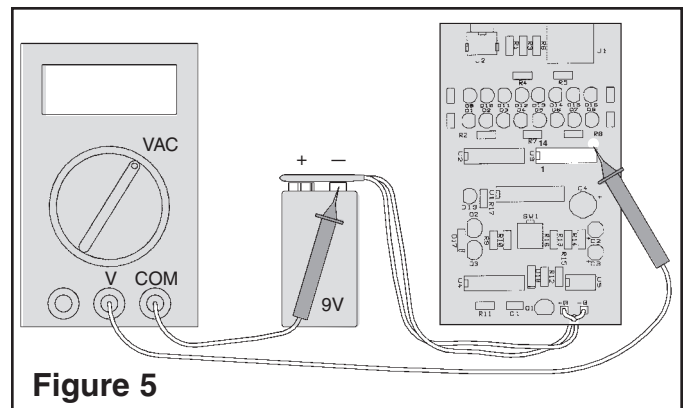

Figure 5

SECTION C

Step Pulses with Counter

PARTS LIST - SECTION C

RESISTORS				
Qty.	Symbol	Description	Color Code	Part #
□ 1	R11	680kΩ 5% 1/4W	blue-gray-yellow-gold	166800
□ 1	R10	1.2MΩ 5% 1/4W	brown-red-green-gold	171200

CAPACITORS				
Qty.	Symbol	Value	Description	Part #
□ 1	C1	.001μF	Discap (102 or .001)	231035

SEMICONDUCTORS				
Qty.	Symbol	Value	Description	Part #
□ 1	U1	4017	Integrated Circuit (IC) Decade Counter	334017

MISCELLANEOUS				
Qty.	Symbol	Description		Part #
□ 1	U1	Socket IC 16-pin		664016

PARTS IDENTIFICATION

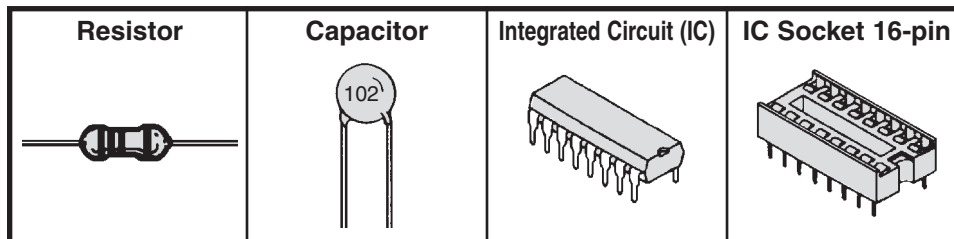

ASSEMBLE THE FOLLOWING COMPONENTS TO THE PC BOARD

In all of the following steps the components must be installed on the top legend side of the PC board. The board is turned to solder the component leads on the foil side.

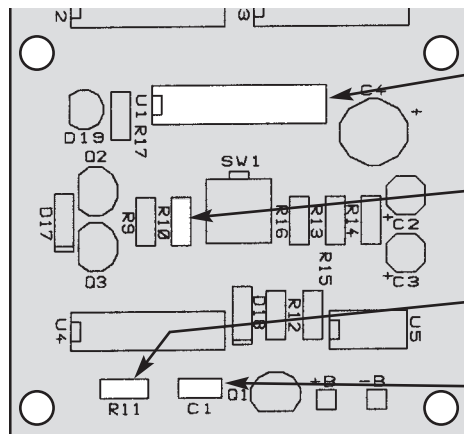
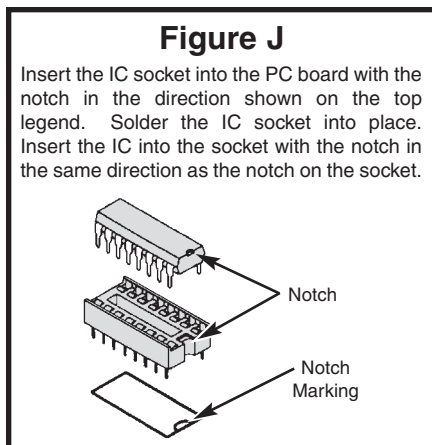

- U1 - 16-pin IC Socket
- U1 - 4017 IC Decade Counter (see Figure J)
- R10 - 1.2MΩ 5% 1/4W Resistor (brown-red-green-gold) (see Figure A)
- R11 - 680kΩ 5% 1/4W Resistor (blue-gray-yellow-gold) (see Figure A)
- C1 - .001μF Discap (102 or .001)

SECTION C - STEP PULSES WITH COUNTER

In this section, a 4017 counter IC and a 40106 inverter IC are used to control eight electronic switches. A short positive pulse must be generated and applied to the clock input of the 4017 IC whenever switch SW1 is depressed. This is done by wiring three inverters in series. When switch SW1 is depressed, the voltage at pin 1 of the 40106 is pulled to ground. This low condition is then inverted three times to produce a positive pulse to the CLK pin of the 4017.

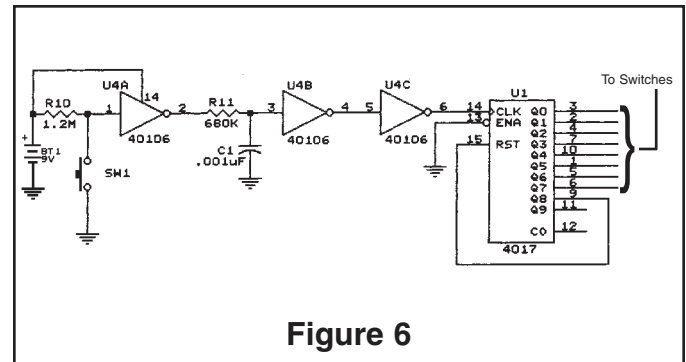

Figure 6

The 4017 IC is a five-stage Johnson decade counter. The IC has 10 outputs, but only one output will be driven high at any given time, the other nine will be low. For each pulse at the clock (CLK) input, the output will move one position. In this design, only eight outputs are used, the ninth output is wired to the reset (RST) pin. When the reset pin goes high, it sets the Q0 output high again. The clock enable (ENA) pin is tied to ground, so every clock pulse will move the output.

TESTING

- 1. Connect the battery to the battery snap.
 - 2. Set the voltmeter to read 20VDC and connect the COM lead to the negative (-) side of the battery and the V lead to pin 3 of IC U1 as shown in Figure 7.
 - 3. Push switch SW1 until the voltmeter indicates 9-10VDC.
 - 4. Move the V lead of the voltmeter to pin 2. The voltmeter should indicate 0V. Push SW1 again. The voltmeter should indicate 8-9VDC.
- In the same manner, test the outputs of the counter (pins 4, 7, 10, 1, 5, and 6).

If the test results are not satisfactory, then:

- a) Check U1. Be sure that it is installed as shown in the assembly instructions.

Remove the battery from the battery snap and the leads from the tester.

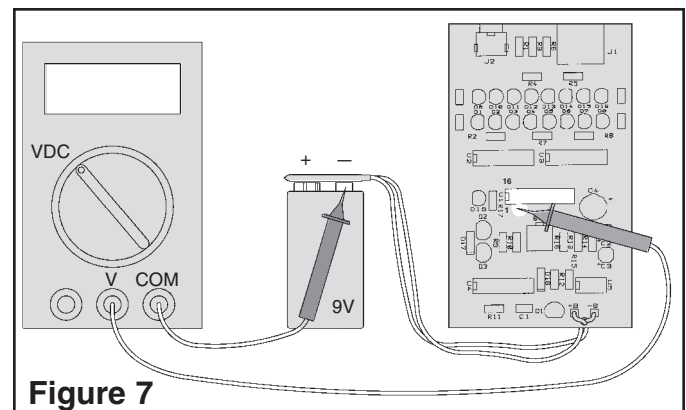

Figure 7

SECTION D

Switches and LED Indicator

PARTS LIST - SECTION D

RESISTORS				
Qty.	Symbol	Description	Color Code	Part #
□ 8	R1-R8	200Ω 5% 1/4W	red-black-brown-gold	132000
CAPACITORS				
Qty.	Symbol	Value	Description	Part #
□ 1	C4	470μF 16V	Electrolytic Radial	284744
SEMICONDUCTORS				
Qty.	Symbol	Value	Description	Part #
□ 16	D1-D16		LED Red	350003
□ 2	U2, U3	74HC4066	Integrated Circuit (IC) Quad Analog Switch	394066
MISCELLANEOUS				
Qty.	Symbol	Description		Part #
□ 1	J2	F-Connector		590500
□ 1	J1	Modular Jack RJ-45		621028
□ 2		Spacer		624006
□ 2	U2, U3	IC Socket 14-pin		664014

PARTS IDENTIFICATION

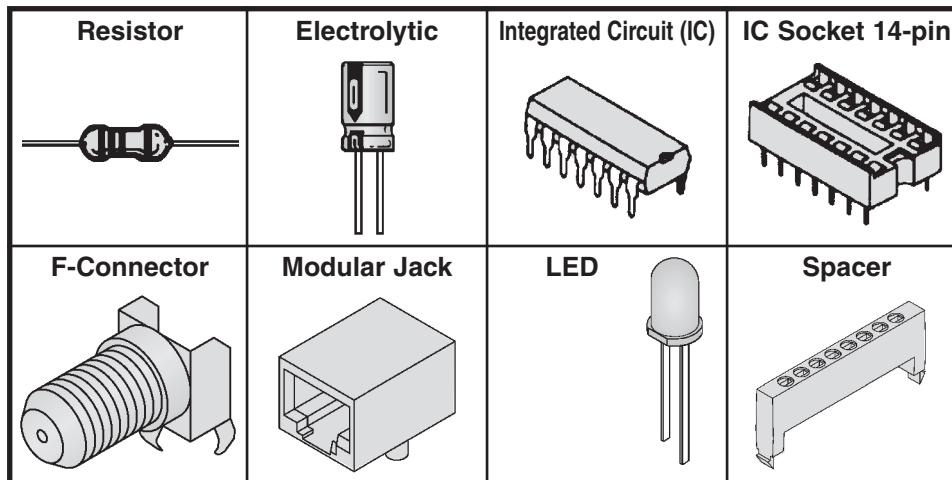

ASSEMBLE THE FOLLOWING COMPONENTS TO THE PC BOARD

In all of the following steps the components must be installed on the top legend side of the PC board. The board is turned to solder the component leads on the foil side.

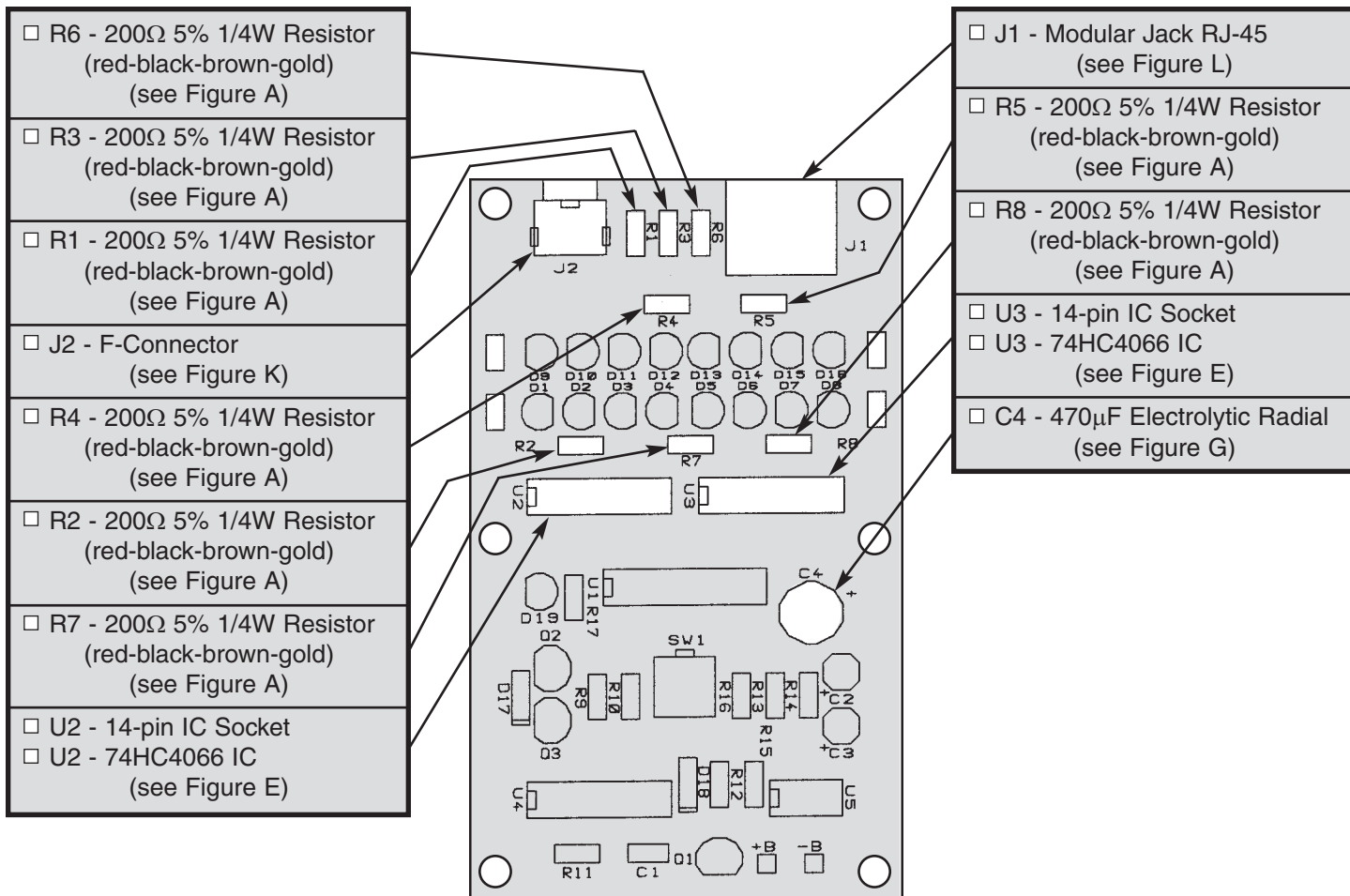

Figure K

Mount and solder the F-connector to the PC board in the location shown. **Note: The connector must be soldered in straight.**

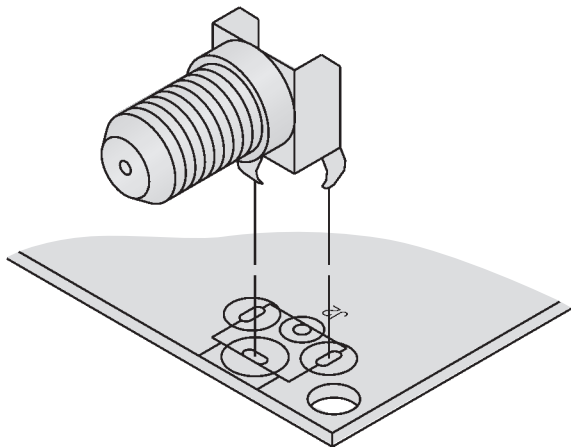
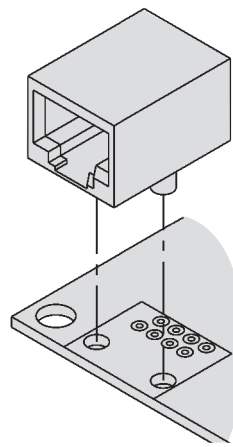

Figure L

Mount and solder the modular jack to the PC board as shown.



ASSEMBLE THE FOLLOWING COMPONENTS TO THE PC BOARD (cont.)

- Spacer
(see Figure M)
- D9 - LED
- D10 - LED
- D11 - LED
- D12 - LED
- D13 - LED
- D14 - LED
- D15 - LED
- D16 - LED
(see Figure N)

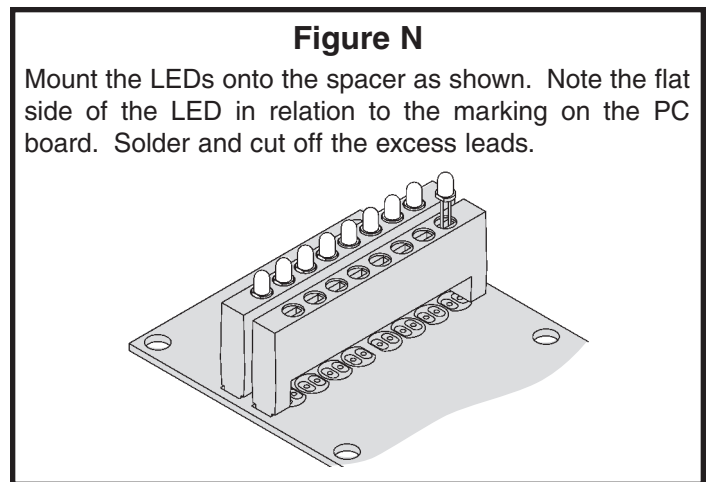
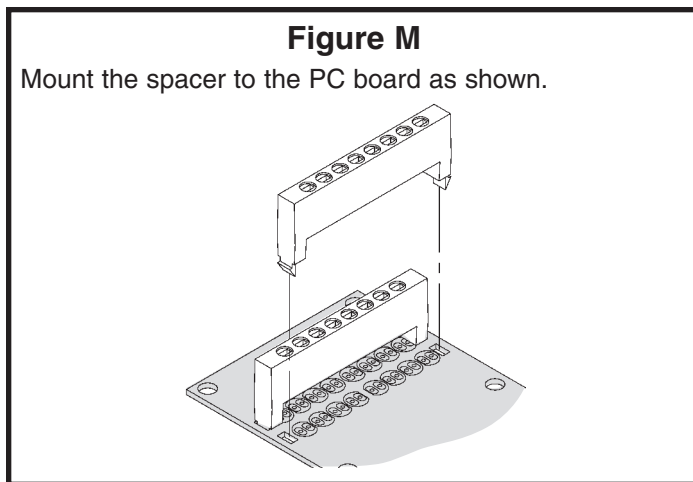
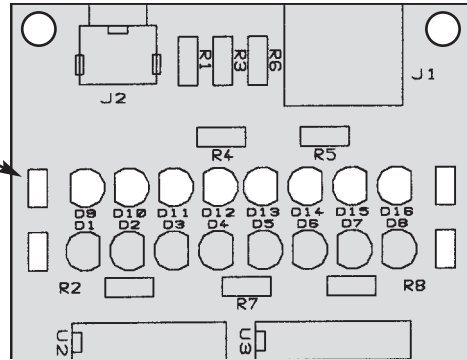

- Spacer
(see Figure M)
- D1 - LED
- D2 - LED
- D3 - LED
- D4 - LED
- D5 - LED
- D6 - LED
- D7 - LED
- D8 - LED
(see Figure N)

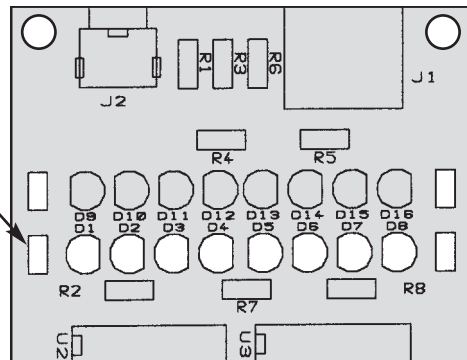

SECTION D - SWITCHES AND LED INDICATOR

In this section, two quad analog switches (74HC4066) and 16 LEDs are used to indicate which pins are being tested and the type of cable. Figure 8 shows the logic diagram for each switch. Each switch contains an input, output and a control pin. The inputs are connected to the oscillator section and the outputs to two LEDs and connector. The control pins connect to the outputs of the 4017 IC (see Figure 10).

When switch A is closed, capacitor C charges and discharges at the oscillator frequency. This causes LEDs D1 and D2 to blink at the same rate (see Figure 9a).

Connecting a straight cable, LED D3 will light only during the charging cycle. The diode in the terminator only allows the current flow in one direction (see Figure 9b).

Connecting a cross-pinning cable, LED D4 will light only during the discharging cycle (see Figure 9c).

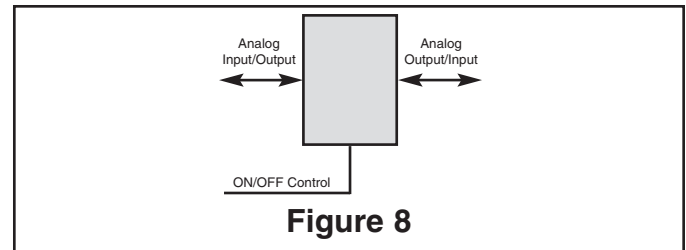
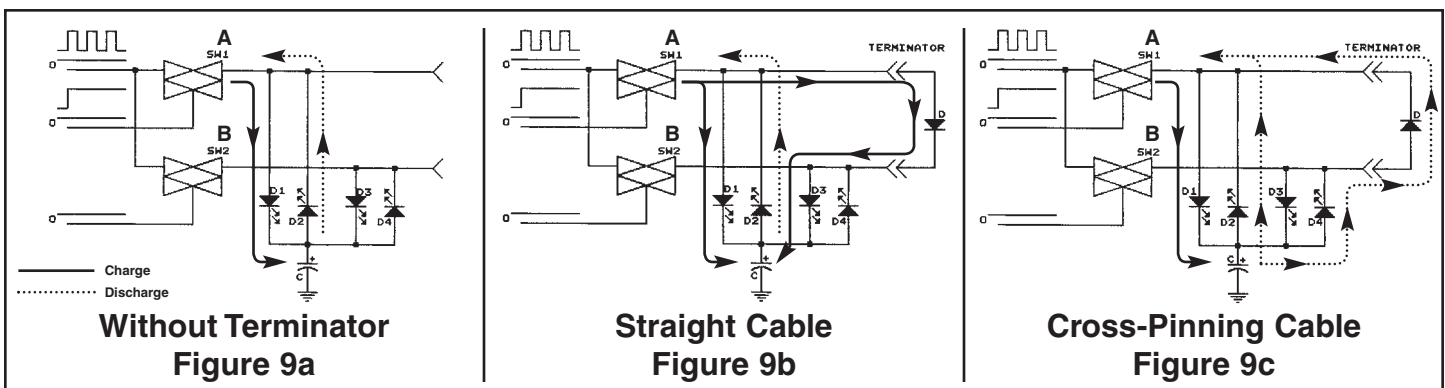

Figure 8



Without Terminator
Figure 9a

Straight Cable
Figure 9b

Cross-Pinning Cable
Figure 9c

TESTING

- 1. Connect the battery to the battery snap.
- 2. Push the switch SW1. Two vertical LEDs should be blinking at a frequency of approximately 8Hz.
- 3. Test the other pairs of LEDs by pushing switch SW1. For every step, there should be only two vertical blinking LEDs. If not, then:
 - a) Check U2, U3, C4 and diodes D1-D16. Be sure that they are installed as shown in the assembly instructions.
 - b) Check that the resistors R1-R8 installed are the correct values.
 - c) Check the soldering on the modular jack and F-connector.

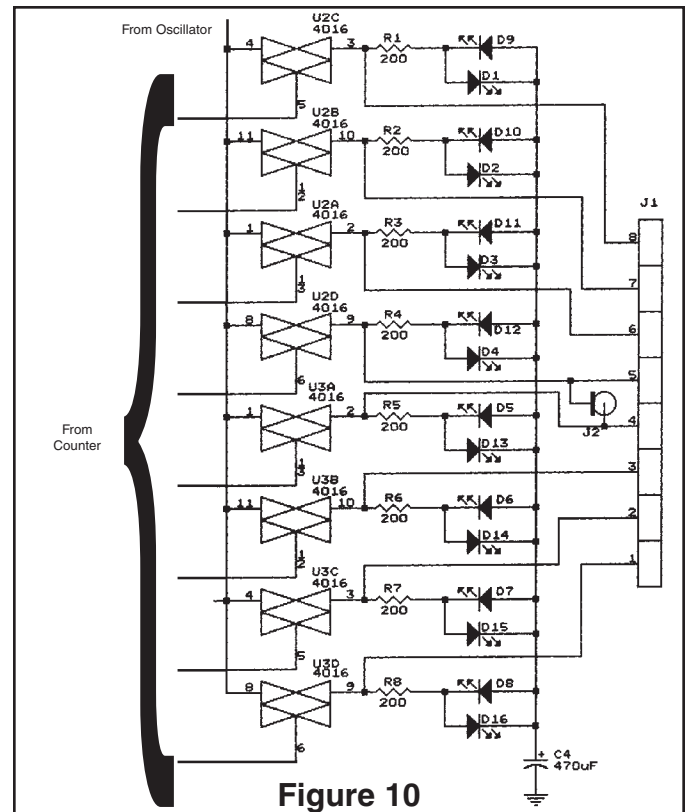

Figure 10

SECTION E

Terminator

PARTS LIST - SECTION E

SEMICONDUCTORS				
Qty	Symbol	Value	Description	Part #
□ 4	D1-D4	1N4148	Diode	314148

MISCELLANEOUS				
Qty	Symbol	Description	Part #	
□ 1		PC Board Terminator LD-100	510005	
□ 1	J2	F-Connector	590500	
□ 1	J1	Modular Jack RJ-45	621028	

PARTS IDENTIFICATION

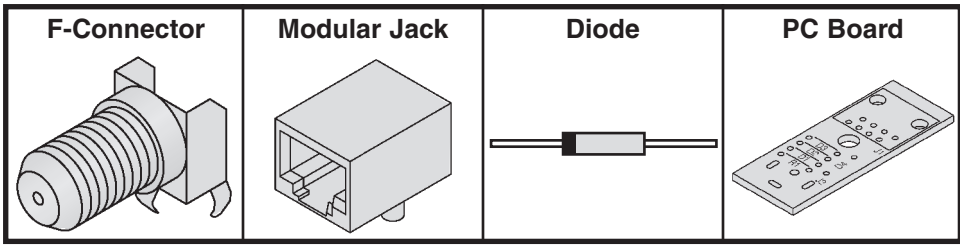

ASSEMBLE THE FOLLOWING COMPONENTS TO THE PC BOARD

In all of the following steps the components must be installed on the top legend side of the PC board. The board is turned to solder the component leads on the foil side.

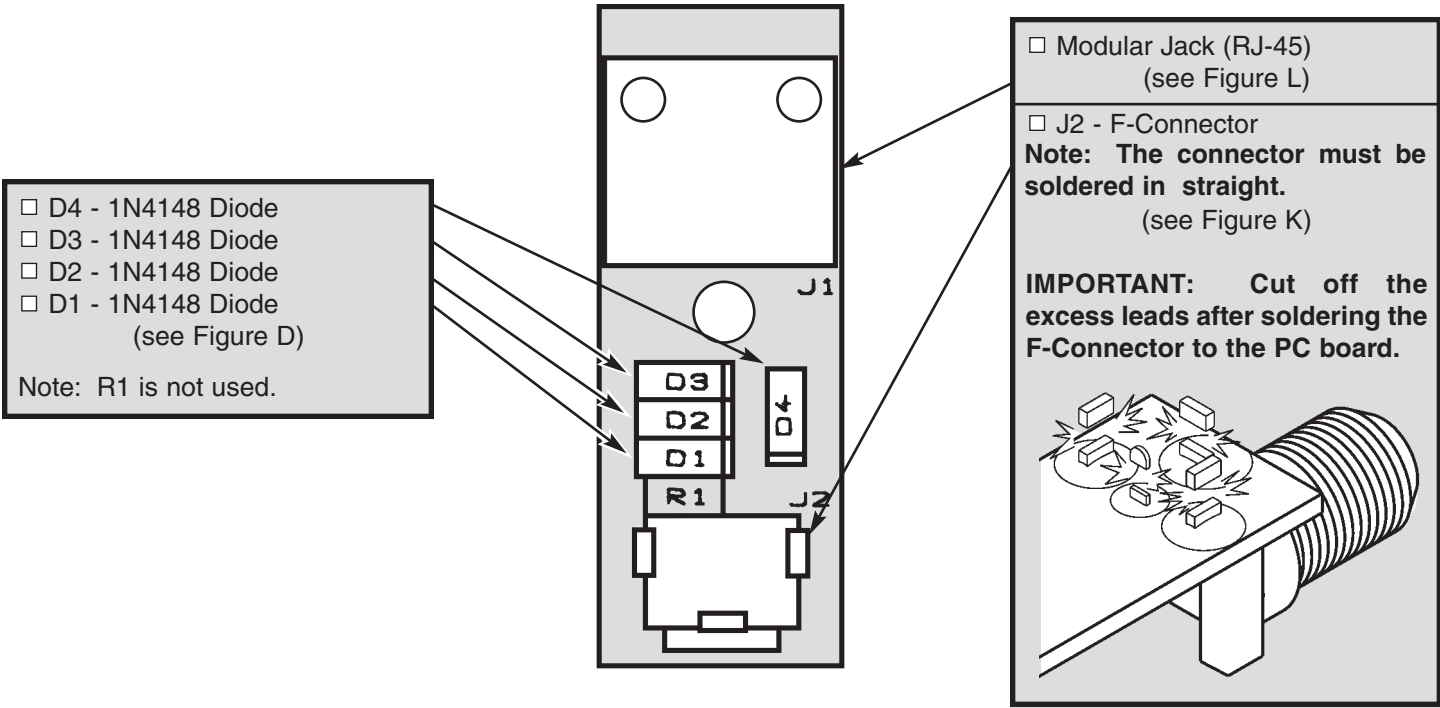

SECTION E - TERMINATOR

The terminator uses four diodes to identify the polarity of the input signals. The diodes are placed in series with wires 1-8, 2-7, 3-6, and 4-5 (see Figure 11).

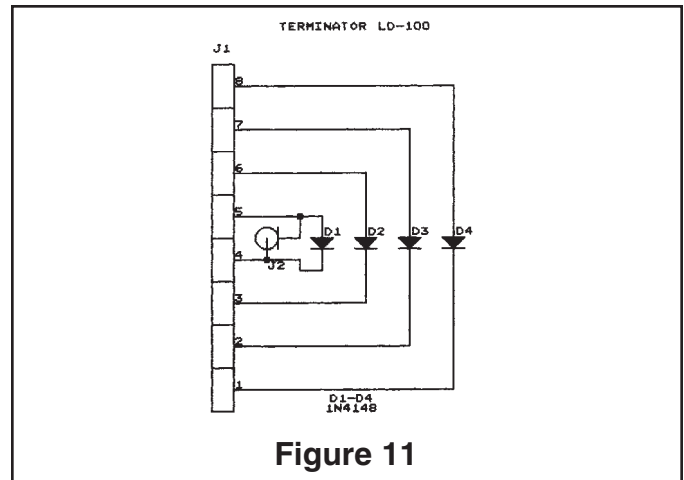

SECTION F

Assemble Telecom Cables

PARTS LIST - SECTION F

MISCELLANEOUS

Qty.	Symbol	Description	Part #
□ 4		Plug RJ-45	621032
□ 2'		Cable Flat 8 Wires	870984

PARTS IDENTIFICATION

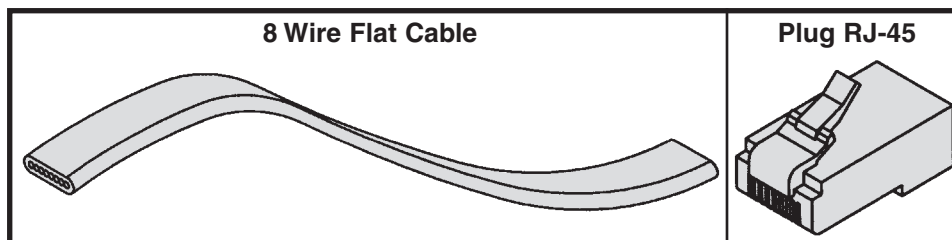

ASSEMBLE THE TELECOM CABLES

For testing and troubleshooting the tester, you need to assemble straight and cross-pinning cables.

For cutting, stripping, and crimping, use a standard tool for RJ-45 plugs (flat cable).

Elenco Electronics has modular crimping tools Models ST-500 and HT-568.

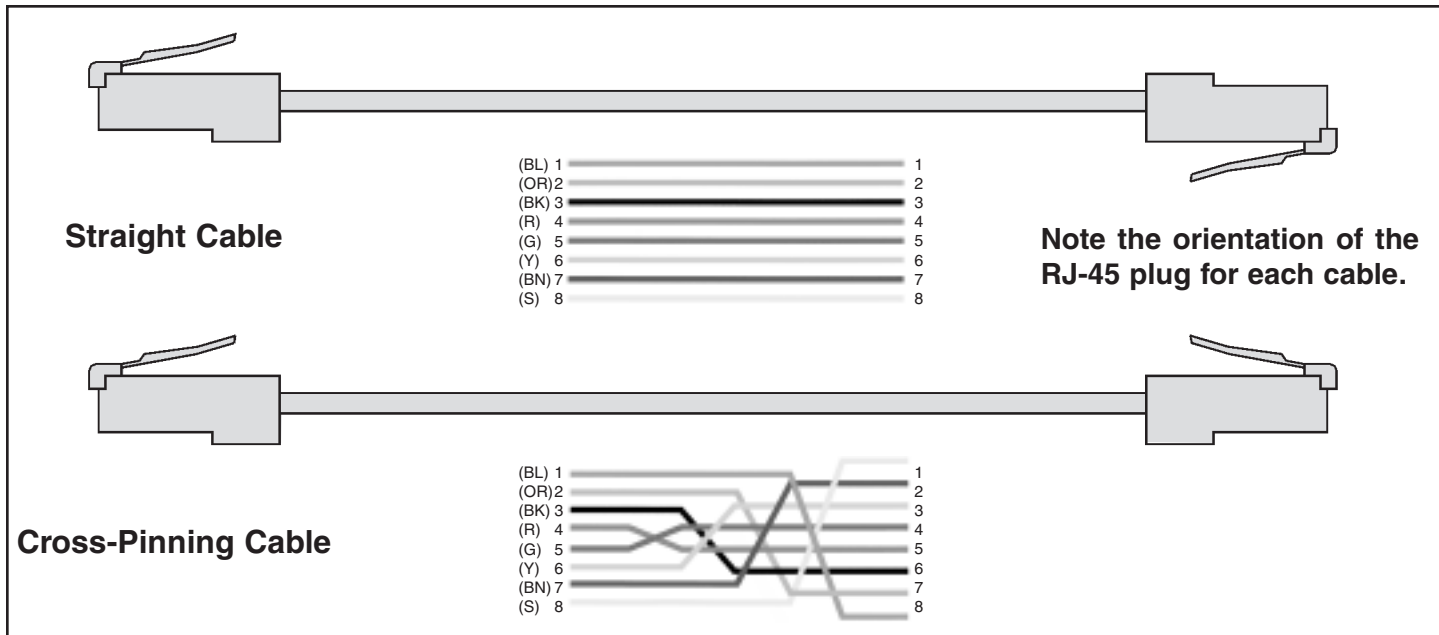

- Cut the 2' telecom cable in half (see Figure 12).
- Using the instructions for your tool, make two cables (straight and cross-pinning) as shown in Figures 13 - 15. Make sure that you make a clean cut on the cable.

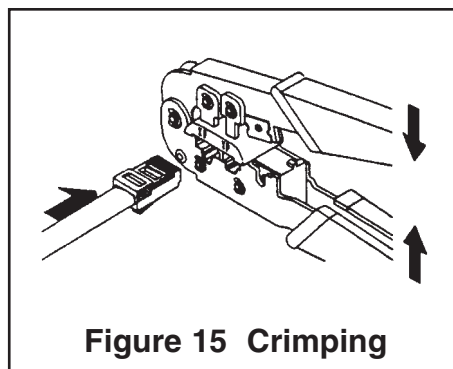
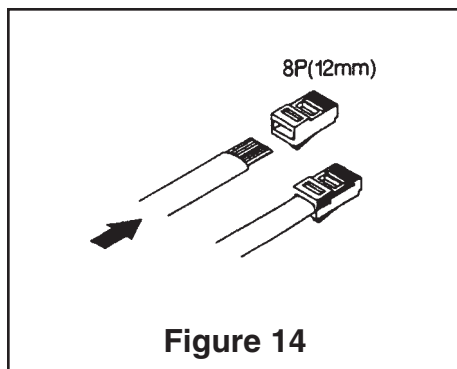
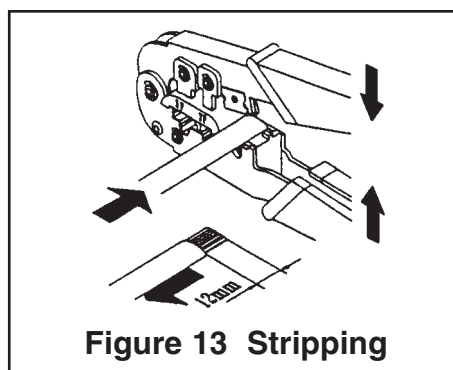
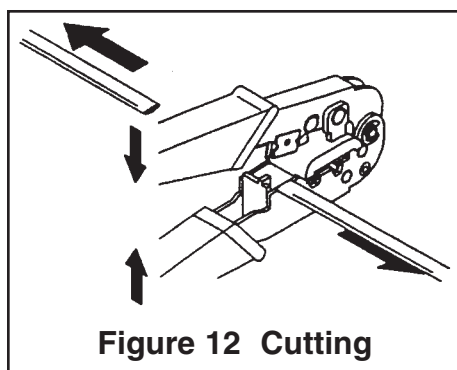

SECTION G

Final Test and Assembly









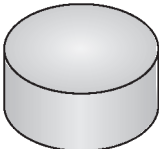

PARTS LIST - SECTION G

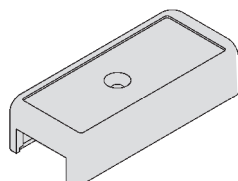
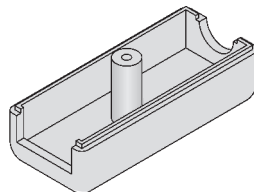
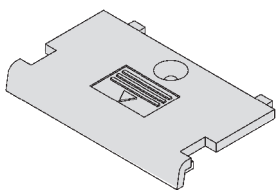
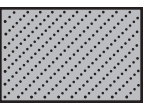
MISCELLANEOUS

Qty.	Symbol	Description	Part #
□ 2		F to BNC Adapter	596020
□ 1		Button Cap	622006
□ 1		Case Top Tester	623114
□ 1*		Case Top Terminator	623115
□ 1		Case Bottom Tester	623211
□ 1*		Case Bottom Terminator	623212
□ 1		Cover Battery	623401
□ 1		Velcro Hook and Loop Set	628002
□ 2		Screw #4 5/16" AB Phillips Pan Head	642442
□ 4		Screw 3 x 12mm Thread Cutting Phillips Flat Head	643104
□ 1		Screw M3 x 10mm Machine Phillips Flat Head	643105
□ 1*		Screw 2.6 x 10mm Thread Cutting Phillips Flat Head	643107
□ 1*		Label Terminator	727050
□ 1		Label Tester	727051

* Used for the assembly of the terminator.

PARTS IDENTIFICATION

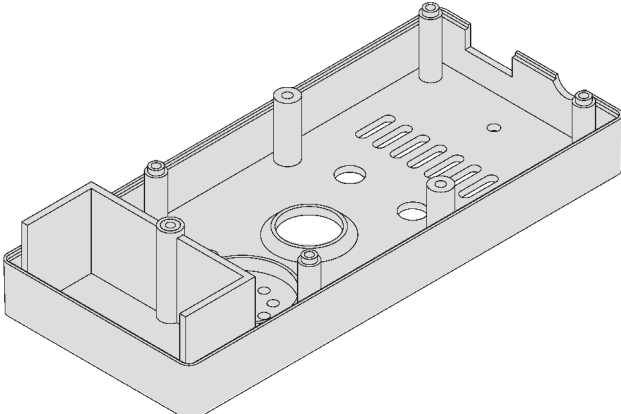
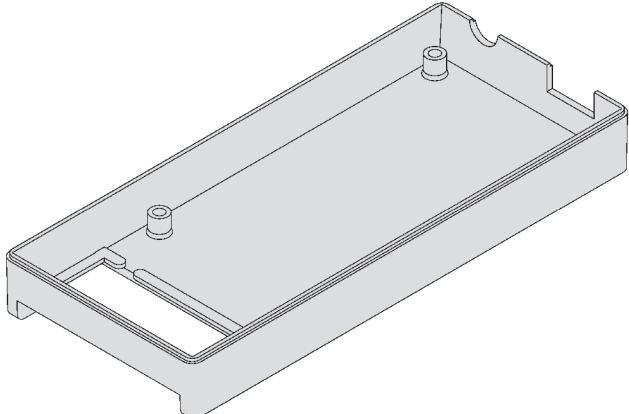
Button Cap 	F to BNC Adapter 	Case Top Terminator 	Case Bottom Terminator 	Cover Battery 
Velcro Hook & Loop Set  <p style="text-align: center;">Hook</p>  <p style="text-align: center;">Loop</p>	Screws (actual size) <div style="display: flex; justify-content: space-around; align-items: center;"> <div style="text-align: center;">  <small>#4 5/16" AB Phillips Pan Head</small> </div> <div style="text-align: center;">  <small>M3 x 10mm Machine Phillips Flat Head</small> </div> <div style="text-align: center;">  <small>3 x 12mm Thread Cutting Phillips Flat Head</small> </div> <div style="text-align: center;">  <small>2.6 x 10mm Thread Cutting Phillips Flat Head</small> </div> </div>		Label Tester 	Label Terminator 
Case Top Tester 			Case Bottom Tester 	

SECTION G - FINAL TEST

Straight Cable

- 1. Connect one end of the straight cable to the modular jack on the PC board of the terminator and the second end to the PC board of the cable tester as shown in Figure 16a.
- 2. Push switch SW1 until the two vertical LEDs D1 and D9 are blinking alternately and LED D16 should be blinking too.

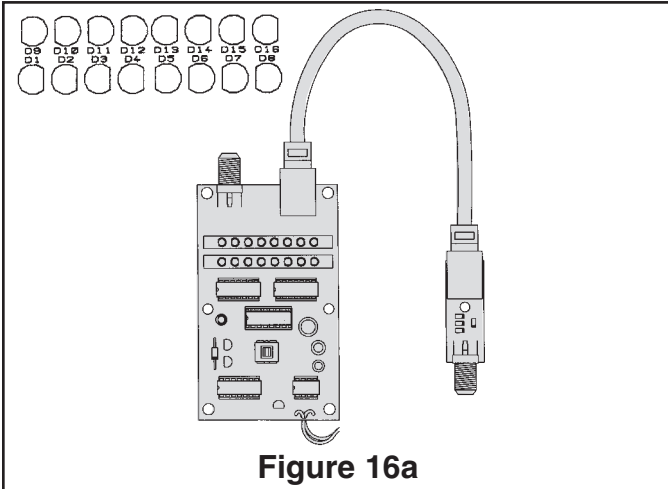

Figure 16a

- 3. Check the other LEDs by pressing switch SW1 and referring to Table 1 below. The single blinking LED should always be on the top row.

Table 1

#	Two Vertical Blinking LEDs	Straight Cable Single Blinking LED on Top Row
1	D1 and D9	D16
2	D2 and D10	D15
3	D3 and D11	D14
4	D4 and D12	D13
5	D5 and D13	D12
6	D6 and D14	D11
7	D7 and D15	D10
8	D8 and D16	D9

If the LEDs are not functioning properly, then:

- a) Check the cable using a master tester.
- b) Check the ICs U2, U3 and LEDs D1-D16 on the PC board of the tester. They should be mounted as shown in the assembly instructions.
- c) Check that resistors R1-R8 on the PC board of the tester are the correct values (200Ω).
- d) Check diodes D1-D4 on the PC board of the terminator. Be sure that the diodes are installed as shown in Figure D in the assembly instructions.

Cross-Pinning Cable

- 1. Remove the straight cable and connect the cross-pinning cable to the modular jacks on the PC boards of the tester and terminator.
- 2. Push switch SW1 until the two vertical LEDs D1 and D9 are blinking alternately and LED D8 should be blinking too.
- 3. Check the other LEDs by pressing switch SW1 and referring to Table 2 below. The single LED should always be on the bottom row. If not, then:
 - a) Check the cable using the master tester.
 - b) Check diodes D1-D4 on the PC board of the terminator. Be sure that the diodes are installed as shown in Figure D in the assembly instructions.

Table 2

#	Two Vertical Blinking LEDs	Cross-Pinning Cable Single Blinking LED on Bottom Row
1	D1 and D9	D8
2	D2 and D10	D7
3	D3 and D11	D6
4	D4 and D12	D5
5	D5 and D13	D4
6	D6 and D14	D3
7	D7 and D15	D2
8	D8 and D16	D1

Short Test

- 1. Push switch SW1 until the two vertical LEDs D4 and D12 are blinking alternately and LED D5 is blinking too.
- 2. Using a short piece of wire or a discarded lead from one of the components, short the F-connector on the terminator PC board as shown in Figure 16b.

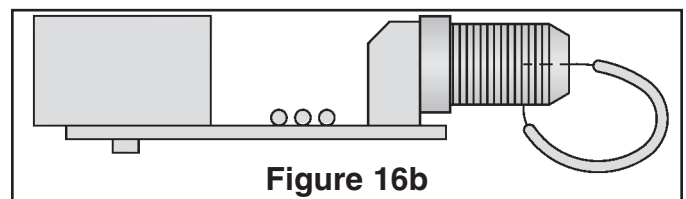

Figure 16b

The LED D13 should be blinking too. Remove the jumper and LED D13 should turn off. If not, then:

- a) Check the F-connector on the terminator PCB.
- 3. Short the F-connector on the tester PC board. The LED D13 should be blinking again. If not, then:
 - a) Check the F-connector on the terminator PCB.
- 4. Remove the cable from the modular jacks on the PC board and proceed to the final assembly.

SECTION G - FINAL ASSEMBLY OF TESTER

- Push the button cap onto the switch as shown in Figure O.
- Mount the PC board to the top case, as shown in Figure P, with two #4 5/16" phillips screws.
Note: The button cap should be centered in the top case hole. Make sure that the Lo Batt LED goes through the hole in the case.
- Wrap the wires from the battery snap around the battery housing as shown in Figure Q.

- Mount the bottom case to the front case, as shown in Figure Q, using four 3 x 12mm flat phillips screws. Be sure that the battery snap is through the battery compartment hole as shown.
- Connect the 9V battery to the battery snap and place it into the case. Slide the battery cover onto the case as shown in Figure R.

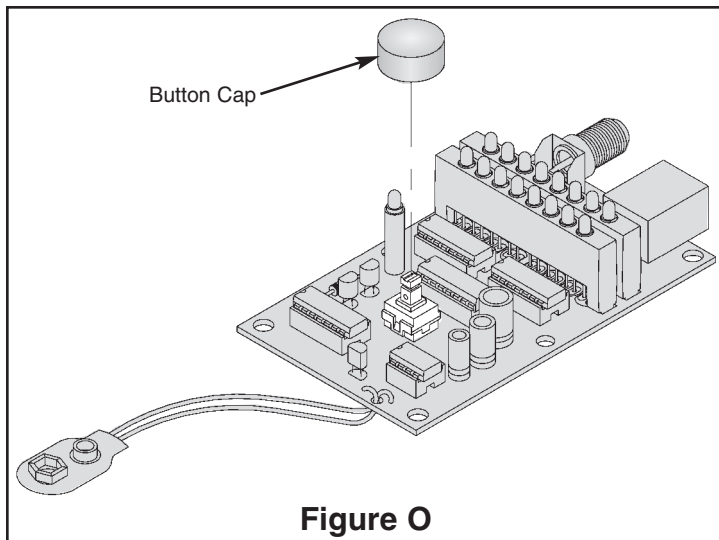

Figure O

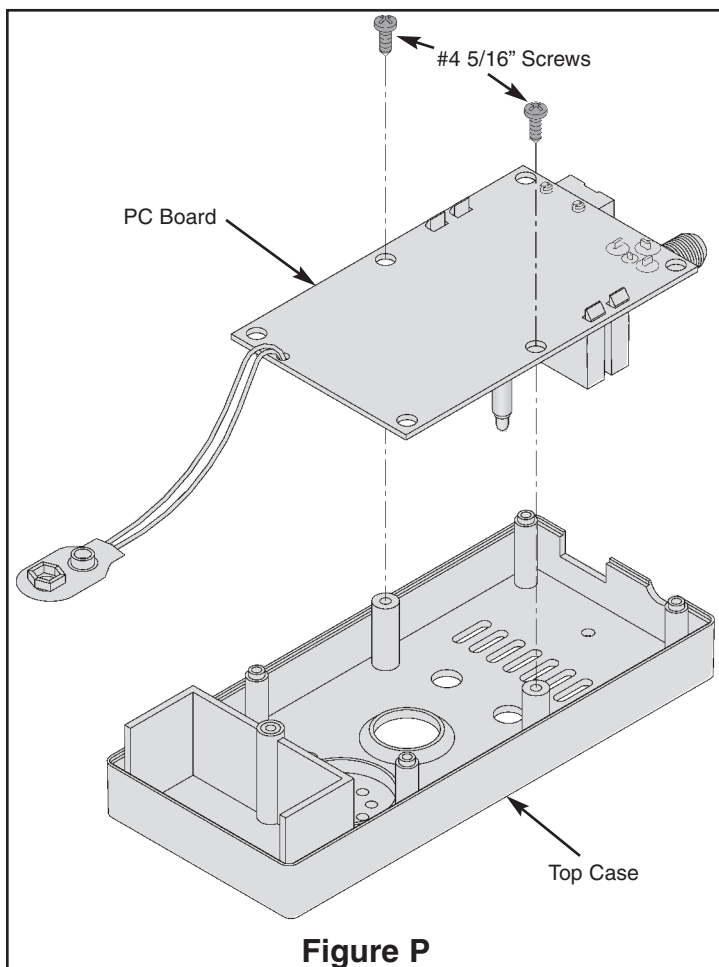

Figure P

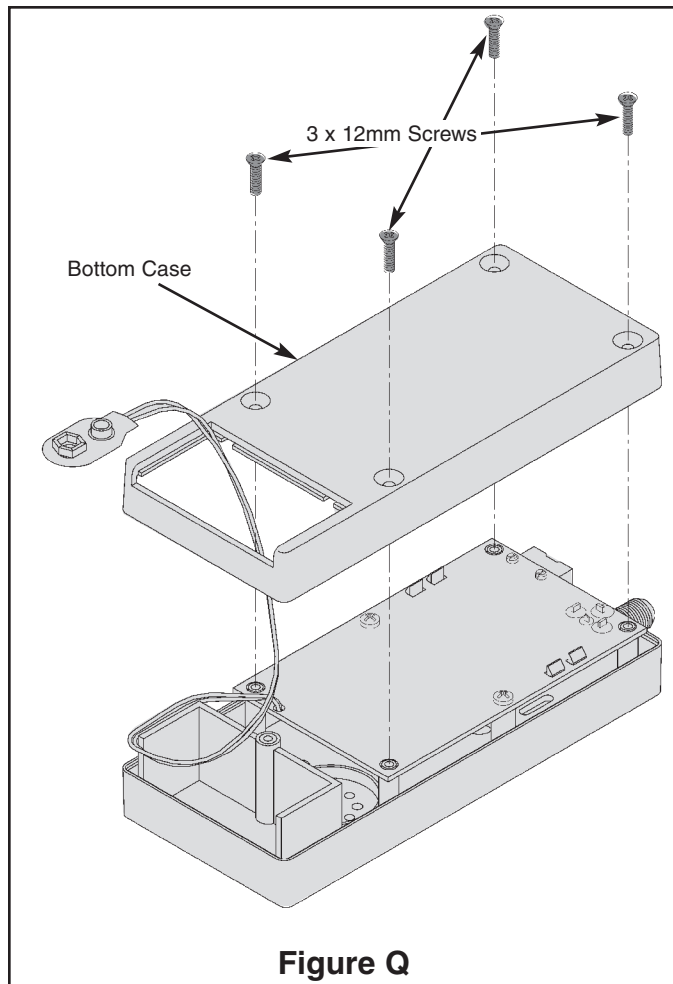

Figure Q

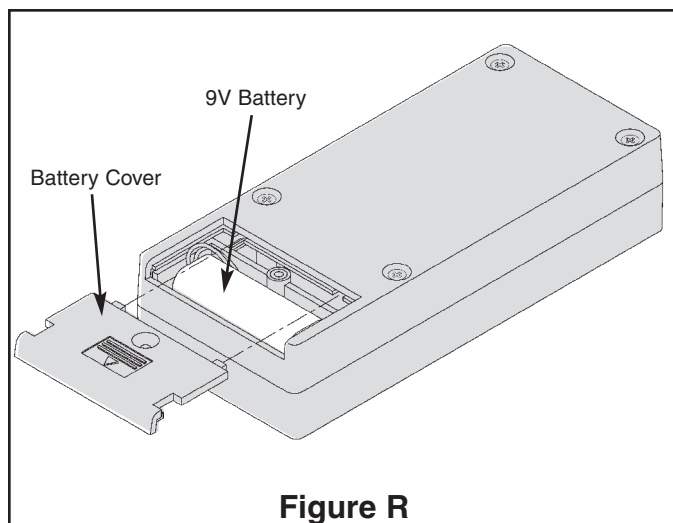
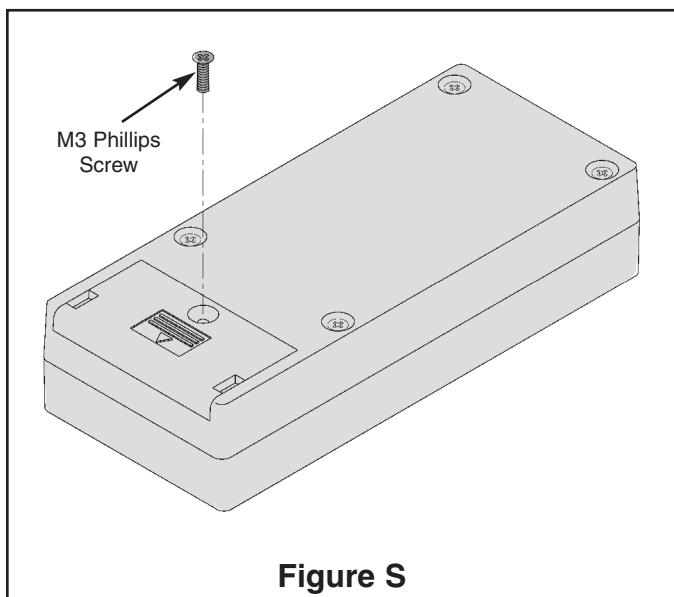

Figure R

FINAL ASSEMBLY OF TESTER (cont.)

- Insert the M3 x 10mm machine phillips screw into the battery cover hole, as shown in Figure S, and tighten.



- Peel the backing off of the label and stick it onto the front case as shown in Figure T. Use the hole in the middle to line up the label. **Note:** Be very careful when applying this label. The adhesive is very sticky and when the label is on, it's on!

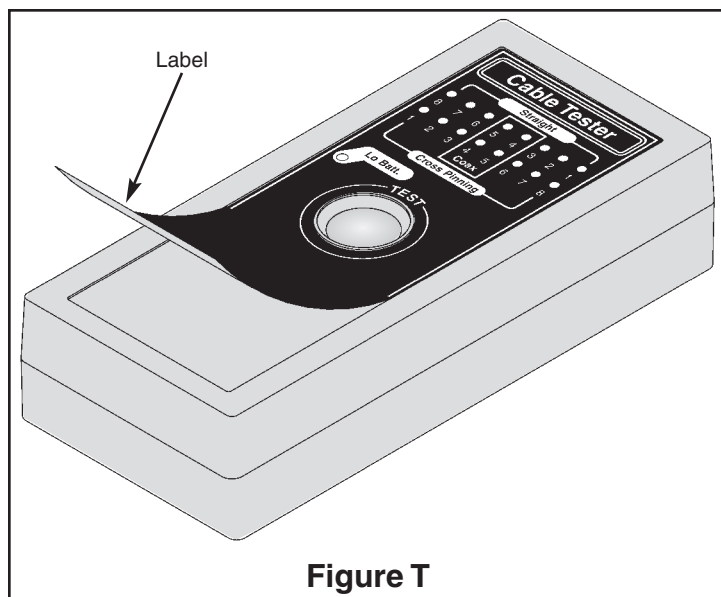

FINAL ASSEMBLY OF TERMINATOR

- Before assembling, check that the excess leads from the F-connector are cut off (see page 16).
- Assemble the terminator as shown in Figure U. Insert the 2.6 x 10mm flat phillips screw and tighten down.

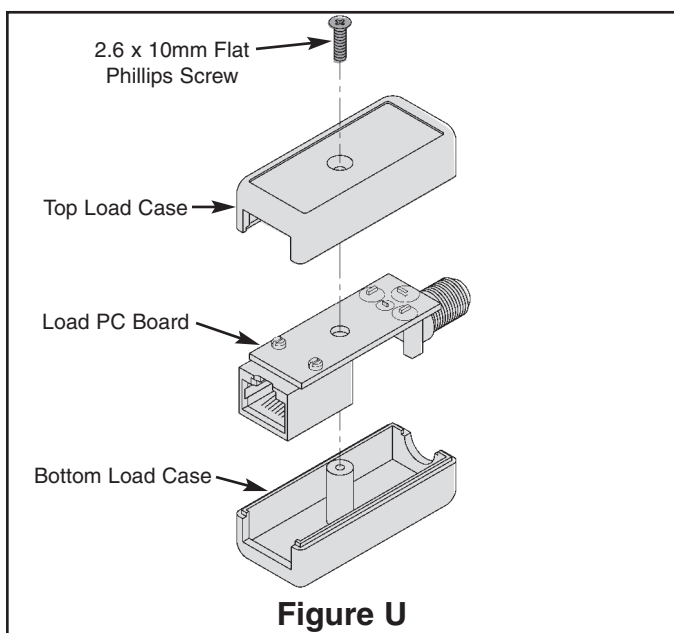

- Peel the backing off of the terminator label and carefully place it onto the unit as shown in Figure V. **Note:** Be sure that the terminator has been tested and is in working order before you apply the label.

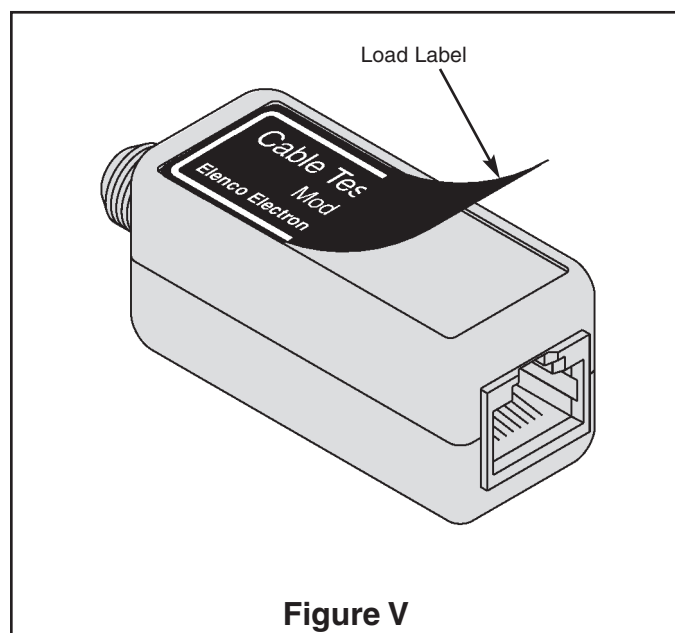

FINAL ASSEMBLY (cont.)

- Peel off the two backings, and attach the two velcro pieces onto the terminator and the tester in the location shown in Figure W.

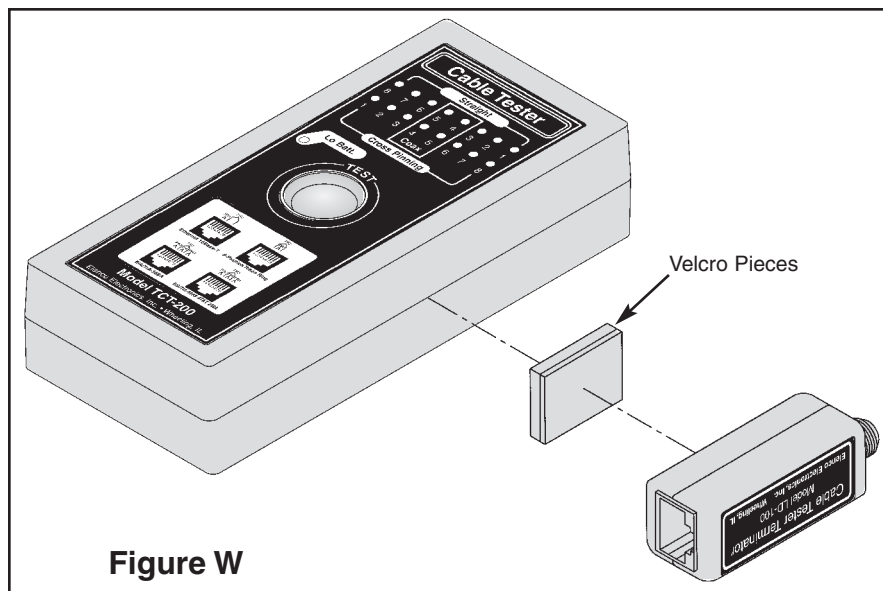

SPECIFICATIONS

CATEGORY OF CABLE

- Unshielded communication cable with RJ-11 and RJ-45 connectors.
- Ethernet 10 Base-T, Token Ring, EIA/TIA-568A/B, AT&T 258A, and USOC.
- 50 or 75Ω coaxial cable with F connectors.
- 50 or 75Ω coaxial cable with BNC connectors. Must use F to BNC adapters.

Maximum testing length for all cable types is 1,000 feet.

MULTIPLE FUNCTIONS

- Testing cables before or after their installation.
- Mapping Function (to test individual wire pairs or coaxial cables).
- Cable identification (straight or cross-pinning).
- Pair identification (straight or cross-pinning).
- Open/short wiring test.

ENVIRONMENTAL CONDITIONS

- Operating Conditions: 0°C - 45°C / 32°F - 113°F
70% RH max.
- Storage Conditions: -10°C - 50°C / 14°F - 122°F
80% RH max.

POWER

- Standard or alkaline 9V battery
- Low battery indicator (Lo Batt.)
- Auto power-off function (30 s)

OPERATION INSTRUCTIONS

1. Connect one end of the cable to be tested to the terminator and the other end to the cable tester as shown in Figure 17.
2. Push the TEST (power) button and read the result.

Good Pair: Two vertical and one single blinking LEDs. The location of the single LED indicates a straight or cross-pinning for the pair.

Open Pair: Only two vertical LEDs blinking.

Short: Four or more LEDs are blinking (two or more wires are shorted).

3. Push the TEST button again and read the result for the next pair.
4. For testing coax cable, use the middle LEDs (boxed in as coax on the unit).
5. If you do not push the button for 30 seconds, it will automatically shut off.

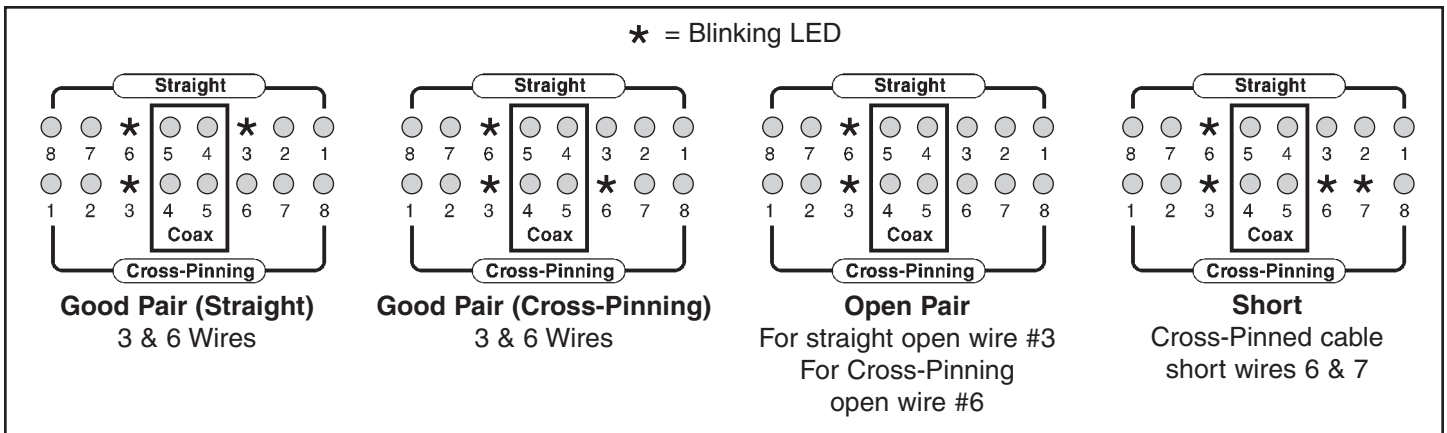

CAUTION

DO NOT test cable connected to electric power. To avoid electric shock, disconnect the power to the cable under test. Connection to an active power cable can result in injury or even death.

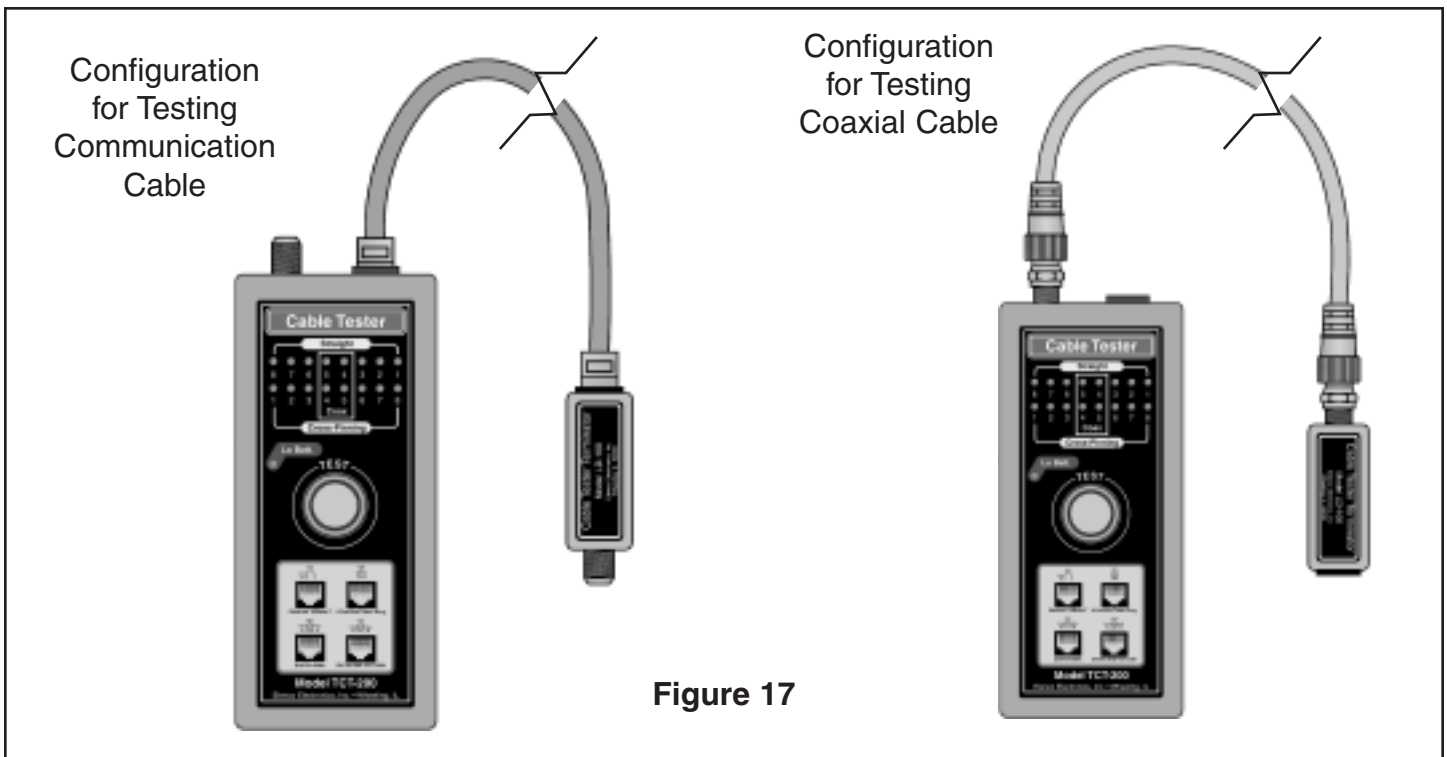

WIRING SCHEMES

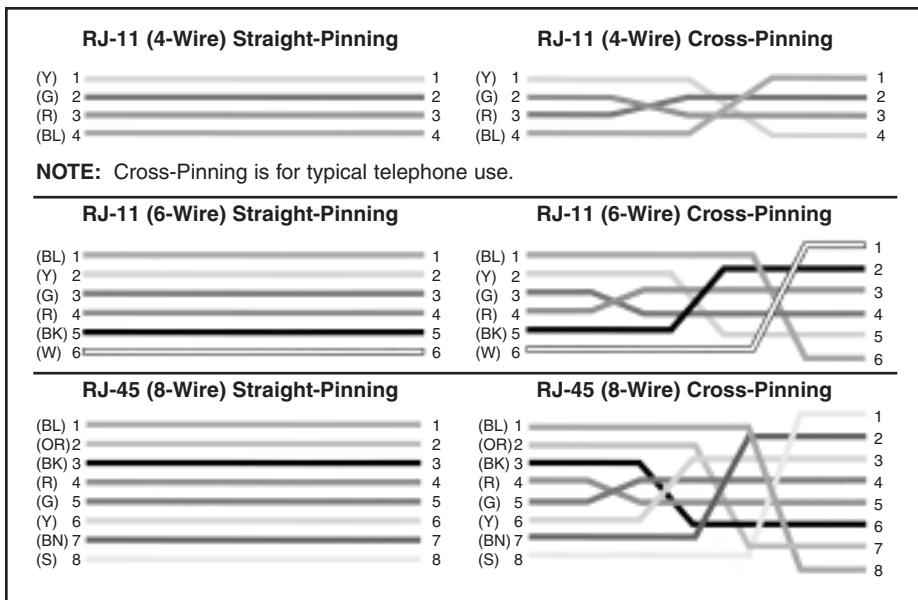
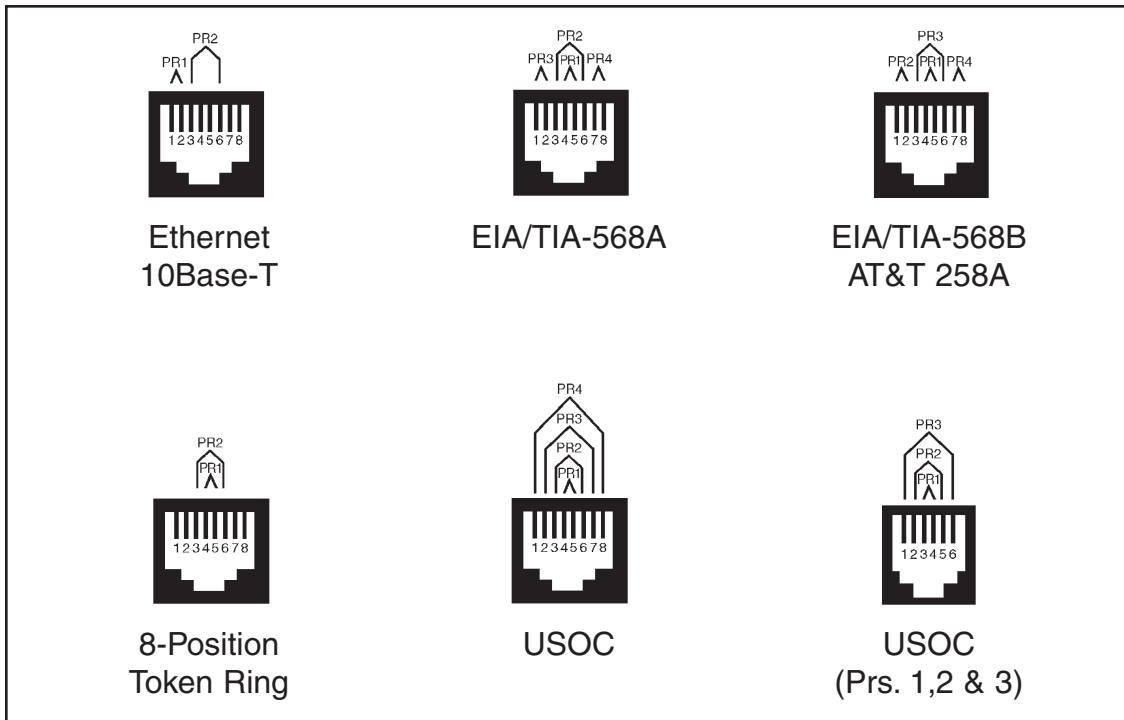

MAINTENANCE

GENERAL MAINTENANCE

To clean, wipe the case with a damp cloth and detergent (do not use abrasives or solvents).

When the Lo Batt. LED lights up, you need to replace the battery. The terminator does not use a battery.

BATTERY REPLACEMENT

The tester is powered by a single standard or alkaline 9V battery. Use the following procedure to replace the battery.

1. Disconnect the cables from the tester.
2. Using a phillips screwdriver, remove the battery cover screw and open the battery cover.

3. Carefully remove the old battery and replace with a new battery.
4. Reinsert the battery into the case, dressing the battery leads so that they will not be pinched between the case and the battery cover.
5. Reinstall the battery cover and screw.

SCHEMATIC DIAGRAM

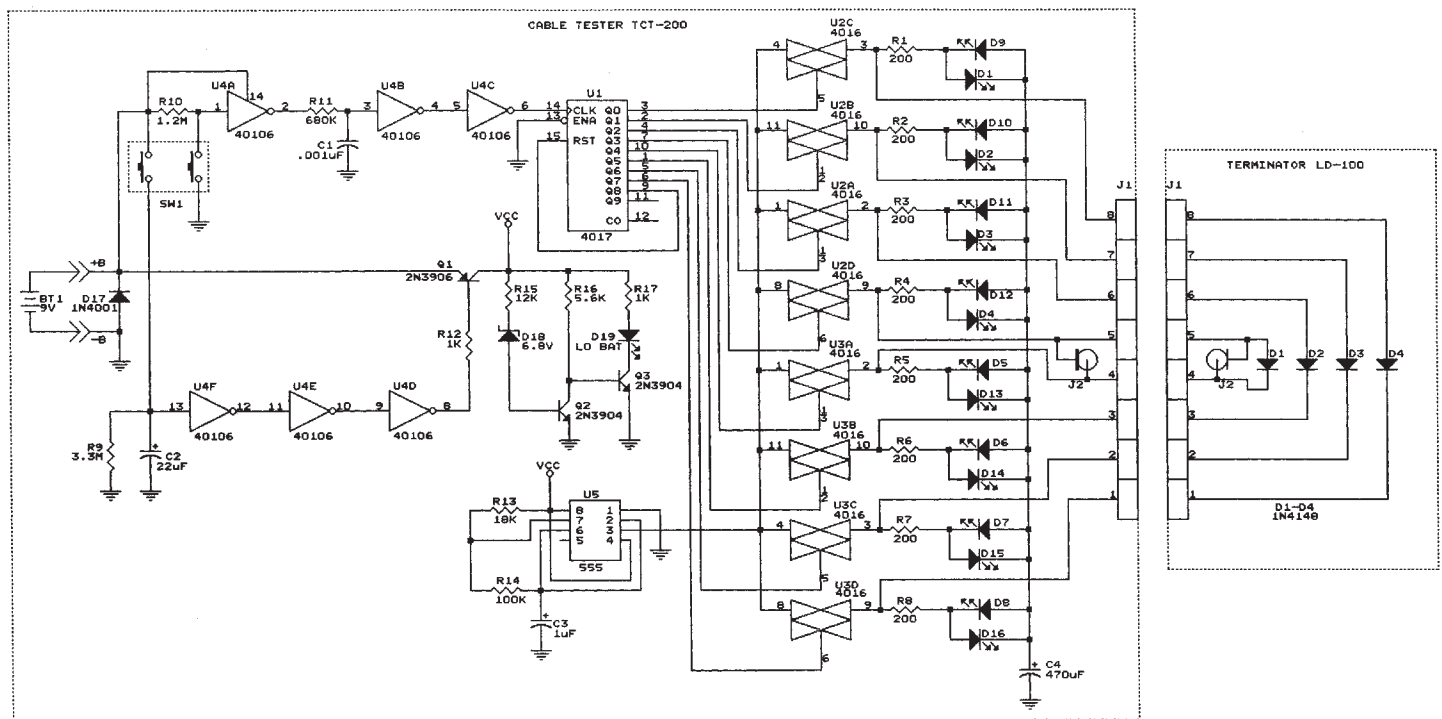

Elenco Electronics, Inc.

150 W. Carpenter Avenue

Wheeling, IL 60090

(847) 541-3800

www.elenco.com

e-mail: elenco@elenco.com