



User Guide

CC8-BLUES • *CompactPCI*[®] Multi-Processing PIII CPU

Document No. 2749 • Edition 1

10-2002



Contents

About this Manual	4
Edition History	4
Related Documents	5
Nomenclature	5
Trade Marks	5
Legal Disclaimer - Liability Exclusion	5
CC8-BLUES Features	6
Short Description	7
Block Diagram	8
Expansion Module CC6-ACID	9
Top View Component Assembly	10
Strapping Headers	11
Connectors & Sockets	11
Front Panel Elements	12
Microprocessor	13
Thermal Considerations	17
Main Memory	23
LAN Subsystem	23
Enhanced IDE Interface	23
Graphics Subsystem	24
Universal Serial Bus (USB)	26
IEEE 1394 / FireWire High Performance Serial Bus	26
Real-Time Clock	26
Watchdog/Reset	28
Firmware Hub (Flash BIOS)	29
Programmable LED	29
Non-Transparent PCI Bridge	30
Hot Swap Controller	32
Geographic Addressing Lines GA0..GA2	33
Installing and Replacing Components	34
Before You Begin	34
Warnings	34
Caution	34
Installing the Board	35
Removing the Board	36
EMC Recommendations	37
Installing or Replacing the Processor	38
Installing or Replacing the Memory Module	38
Replacement of the Battery	39
Technical Reference	40
Local PCI Devices	40
Local SMB Devices	40
Connectors	41

Caution	41
Front Panel Connectors	41
Video Monitor Connector MON	42
USB Connector	44
Ethernet Connector	44
IEEE 1394 / FireWire Connectors	45
Internal Connectors	46
ATA CompactFlash Socket	46
LPC Low Pin Count Header	47
Fan Heatsink Pin Row	48
Speaker Pin Row	48
PLD Programming Pin Row	48
Hot Swap Micro Switch Pin Row	48
Processor Debug Header	49
CompactPCI J1	50
CompactPCI J2	51
Power Supply Requirements	52
Literature	52



About this Manual

This manual describes the technical aspects of the CC8-BLUES, required for installation and system integration. It is intended for the experienced user only.

Edition History

Document	Ed.	Contents/ <i>Changes</i>	Author	Date
Text # 2749	1	1. Edition User Manual CC8-BLUES English, reflects board rev.1	jj	25 October 2002

Related Documents

For a description of the CC8-BLUES BIOS refer to document 'CC5-RAVE BIOS Quick Reference', available by download at <http://www.ekf.de/c/ccpu/cc5/cc5.html>.

Nomenclature

Signal names used herein with an attached '#' designate active low lines.

Trade Marks

Some terms used herein are property of their respective owners, e.g.

Pentium, Celeron, Socket 370: ® Intel

CompactPCI: ® PICMG

Windows 98, Windows NT, Windows 2000: ® Microsoft

EKF does not claim this list to be complete.

Legal Disclaimer - Liability Exclusion

This manual has been edited as carefully as possible. We apologize for any potential mistake. Information provided herein is designated exclusively to the proficient user (system integrator, engineer). EKF can accept no responsibility for any damage caused by the use of this manual.

CC8-BLUES Features

Summary of Features CC8-BLUES	
Form Factor	Single size <i>CompactPCI</i> style Eurocard (160x100mm ²), front panel width 4HP (20.3mm)
Processor	Support for Intel® Celeron™ and Pentium® -III (0.18µ Coppermine series) processors, 370-pin PPGA or FC-PGA package
Chip Set	i810 or i810E chip set consisting of: <ul style="list-style-type: none"> • 82810 Graphics/Memory Controller Hub (GMCH) • 82801 I/O Controller Hub (ICH0) • 82802 Firmware Hub (FWH)
Memory	<ul style="list-style-type: none"> • 144-pin dual in-line memory module (SO-DIMM) socket, module height 1.1inch (28mm) max. • Support for up to 256MB, non ECC, unbuffered synchronous DRAM (SDRAM) • Support for serial presence detect (SPD) and non-SPD SO-DIMMs, PC-100 style
Video Output	Analog monitor output (front panel), up to 1280x1024 pixel 16M colours 85Hz refresh rate, HarLink connector (front panel, HarLink to VGA adapter cable available)
USB I/O	Single type A connector (front panel), USB1.1, data transfer rate of up to 12Mbit/s, short-circuit protected by electronic power switch, nominal maximum current 0.5A
Ethernet I/O	100Base-Tx/10Base-T Fast-Ethernet controller, RJ45 connector (front panel), 100Mbps full-duplex, auto-negotiation
IEEE 1394 FireWire	Integrated 1394a-2000 OHCI PHY/Link-Layer Controller, dual ports, 6-position receptacles (front panel), 400Mbps data transfer rate, remote power distribution, short-circuit protected by electronic regulator, nominal maximum current 0.5A
Legacy I/O	LPC Super-I/O interface connector, CC6-ACID companion board with Super-I/O controller available
IDE/ATA	CompactFlash type II socket for CF ATA Flash cards and CF ATA Microdrives (Secondary IDE)
<i>CompactPCI</i>	32/64-bit, 33.3MHz, non-transparent PCI bridge 133/266MByte/s
Hot Swap Function	Board installing and removing without adversely effecting a running system, "Full Hot Swap" implementation according to CompactPCI Hot Swap Specification PICMG® 2.1
BIOS	General Software BIOS for embedded systems, 2..8Mbit Flash memory (Firmware Hub)

Short Description

The CC8-BLUES was designed for CompactPCI® multi-processing systems, with several CPU boards sharing a common CPCI backplane. Likewise equipped with an Intel Celeron® or Pentium-III® up to 1GHz, the 3U single-size Eurocard provides for a dual IEEE 1394 port, Ethernet, USB and graphics interface.

A CompactFlash socket holds either an ATA Flash card (silicon disk) or an IBM Microdrive, useful as on-board mass storage and boot device.

With multi-processing systems and high density cluster computing in mind, several CC8-BLUES as slaves can coexist with any system-controller CPU acting as master on a common CompactPCI backplane. Due to its low-profile passive heatsink, the hot swap capable board requires only 4HP mounting space.

With a variety of different interfaces and its excellent computing power, the CC8-BLUES copes perfectly with any communications task.

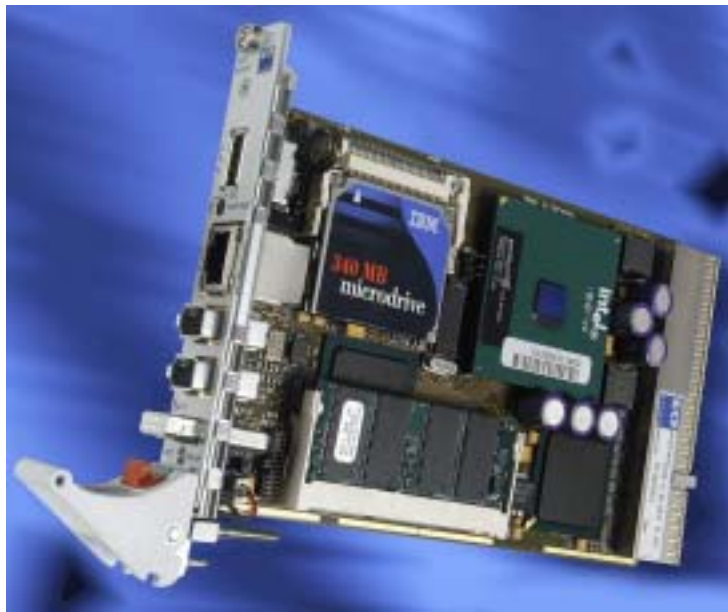

Block Diagram

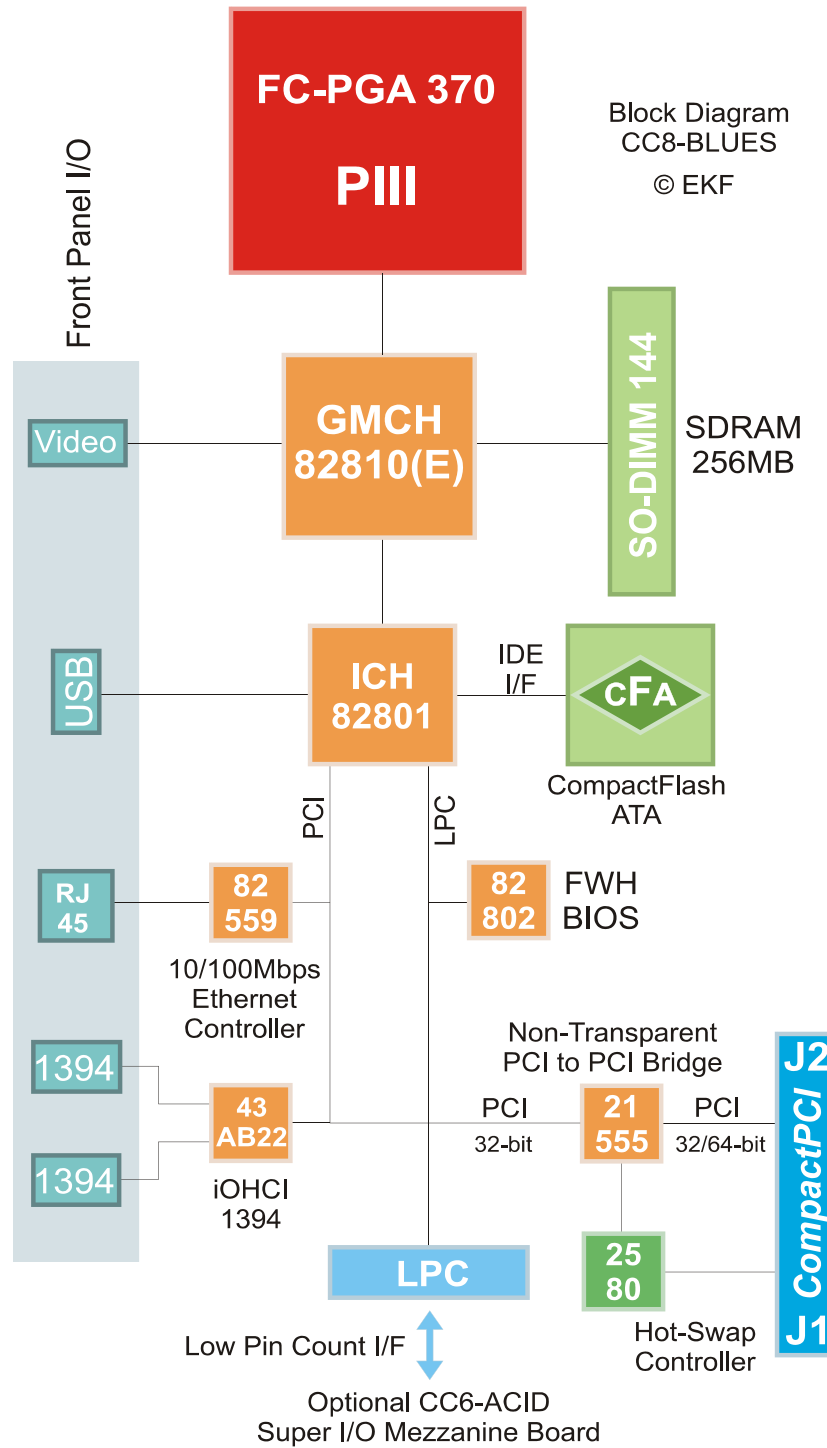

Expansion Module CC6-ACID

Available as a companion board to the CC8-BLUES, the CC6-ACID is provided with all PC legacy I/O ports. This module fits on either side of the CC8, top (CC6-1 and CC6-3) or bottom (CC6-3 only), utilizing the LPC Low Pin Count interface. The card will be required only if the classical interfaces, e.g. serial and parallel port remain in use in a given application.

The connectors LPT (CC6-1 only), COM1/2, mouse and keyboard are situated at the front panel, while a floppy disk drive can be attached via the on-board pin header. While the CC6-1 requires 8HP, the CC6-3 is equipped with a 4HP front panel.

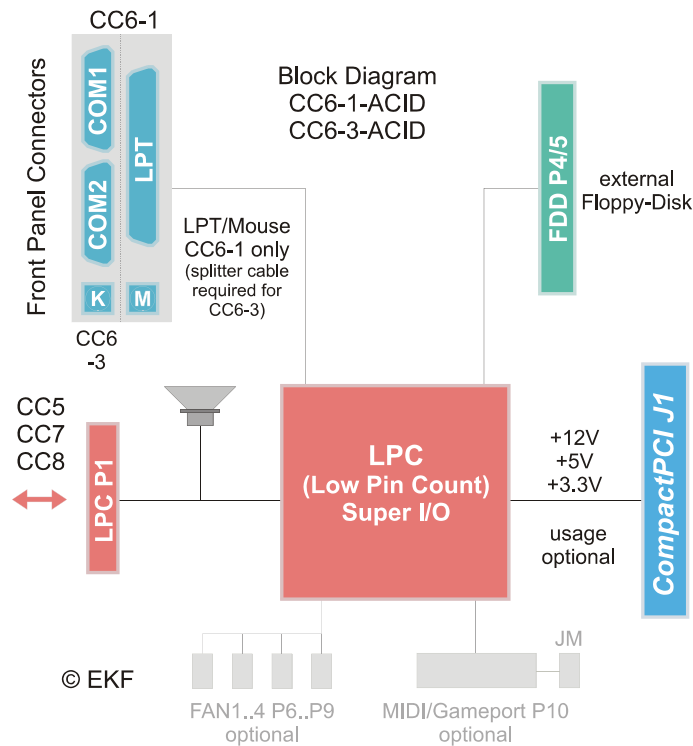

CC8-BLUES & CC6-ACID (similar image)

Top View Component Assembly

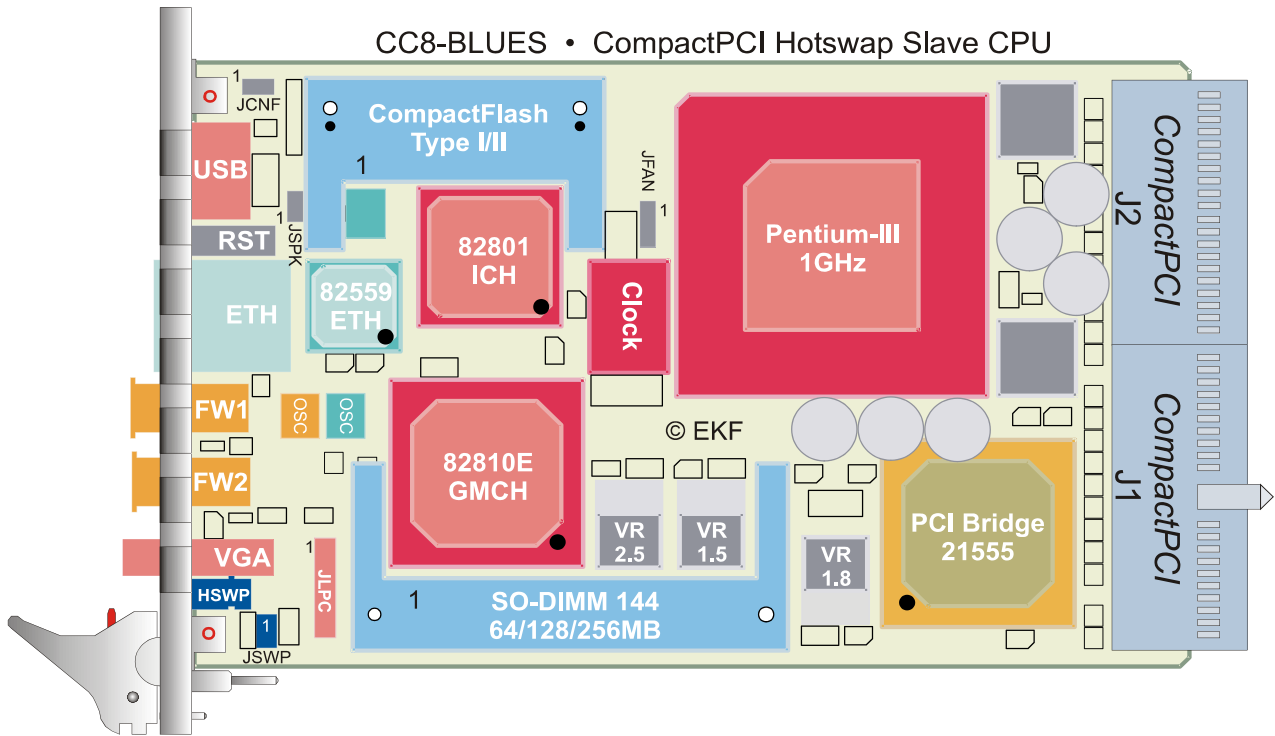

Strapping Headers

ISPCON	In System Programmable GAL (PLD programming), not stuffed
JFAN	Cooling fan connector, 12V or 5V fixed operation
JSPKR	Speaker connector
JSWAP	Interface to the board ejector micro switch (hot swap)

Connectors & Sockets

CFA1	CompactFlash ATA socket (secondary EIDE interface)
J1/J2	<i>CompactPCI</i> Bus
PLPCT PLPCB	Low Pin Count expansion interface connector (Super-I/O), available either from top (T) or bottom (B) of the board
PITP	CPU Debug Port, not stuffed
SODIMM1	144-pin memory module

Front Panel Elements

1394-1	IEEE 1394a (FireWire) 400Mbps serial interface port 1
1394-2	IEEE 1394a (FireWire) 400Mbps serial interface port 2
Ethernet	100BaseTX/10BaseT, RJ-45 receptacle with indicator LEDs
Graphics	DVI-I receptacle, suitable for DVI digital flat panel displays and/or analog monitors
Hot Swap Micro Switch	A switch integrated into the ejector handle signalling the request for removing the board (this push-button unlocking switch must be pressed before the ejector lever can be actuated)
MON	Monitor - VGA video output <i>har-link</i> female metric connector (adapter cable to HD-SUB 15 available as accessory)
USB	Universal Serial Bus 1.1 self powered root hub, type A receptacle
Reset	Push-button switch with indicator LED (power good)
ACT	LED signalling activity on either or both of the 1394 ports
IDE	LED indicating IDE activity (ATA CompactFlash Card or MicroDrive)
Hot Swap	LED signalling that the board can be removed when lit

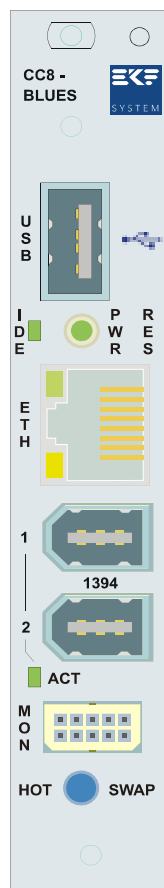

Microprocessor

The CC8-BLUES supports 370-pin PPGA and FC-PGA socketed Celeron processors and FC-PGA housed Pentium-III processors listed below. The FC-PGA processors are also known as Coppermine 0.18 μ generation (CPU ID 068xh). The CC8 is not suitable for newly available Tualatin 0.13 μ FC-PGA2 processors. The CC8 is also not suitable for older 'slot style' Celeron and Pentium-II processors. The Socket 370 also is not compatible with Socket 7 processors (e.g. Pentium-MMX, K6). The table below lists typical processors available for the CC8-BLUES (there might be other resources not mentioned here). **Please note: Use of any processor not supported can cause permanent damage to the processor and the CC8-BLUES!**

Neither have all of the CPU types mentioned in the tables below been tested by EKF for use with the CC8-BLUES, nor does EKF claim that the entire range of processors is available for purchase. Instead, please refer to the EKF price list http://www.ekf.de/liste/liste_20.html for availability of the CC8-BLUES with particular processors (your individual request to sales@ekf.de is highly appreciated).

Please do not attempt to change or remove the installed processor by yourself. The CC8-BLUES is equipped with a non-ZIF processor socket, which requires special handling to remove the CPU. In addition, the passive heatsink is fixed by several screws, which need to be precisely adjusted in order to achieve the optimum heat conduction. Furthermore, the heatsink is fixed with conductive pads and/or adhesion to the Coppermine processors hot spot, which cannot be removed and renewed without suitable material and knowledge. If it is required to identify a particular processor, use suitable software instead, like Intel's freely available Processor Frequency ID Utility.

Do not confuse the processor host bus frequency (FSB front side bus) with the memory speed or the PCI clock, which are independent from each other. The processor signals its appropriate basic speed by two pins to the chipset, which is thereby adjusted automatically (no user interaction required). The internal CPU speed is achieved by multiplying the host bus frequency by a fixed value.

The CC8-BLUES is powered across the CompactPCI connectors J1/J2 (3.3V, 5V, 12V). The processor core voltage is generated by a switched voltage regulator, sourced from the 5V plane. Any FC-PGA 370 processor signals its required core voltage by 4 (Intel) dedicated pins, hence there is no need (no choice) for user adjustment. Manipulation of these parameters (the euphemistic term 'tuning' is widely in use for that) may lead to unpredictable results.

Celeron® Processors Currently Supported (as of 05/2002)

Processor	Speed	Host Bus	L2 Cache	CPU ID	Package	Stepping
Celeron 1.1G	1.1GHz	100MHz	128KB	068Ah	FC-PGA	DO
Celeron 1G	1GHz	100MHz	128KB	068Ah	FC-PGA	DO
Celeron 950	950MHz	100MHz	128KB	068Ah	FC-PGA	DO
Celeron 900	900MHz	100MHz	128KB	068Ah	FC-PGA	DO
Celeron 850	850MHz	100MHz	128KB	068Ah	FC-PGA	DO
Celeron 850	850MHz	100MHz	128KB	0686h	FC-PGA	CO
Celeron 800	800MHz	100MHz	128KB	068Ah	FC-PGA	DO
Celeron 800	800MHz	100MHz	128KB	0686h	FC-PGA	CO
Celeron 766	766MHz	66MHz	128KB	068Ah	FC-PGA	DO
Celeron 766	766MHz	66MHz	128KB	0686h	FC-PGA	CO
Celeron 733	733MHz	66MHz	128KB	068Ah	FC-PGA	DO
Celeron 733	733MHz	66MHz	128KB	0686h	FC-PGA	CO
Celeron 700	700MHz	66MHz	128KB	0686h	FC-PGA	CO
Celeron 700	700MHz	66MHz	128KB	0683h	FC-PGA	BO
Celeron 667	667MHz	66MHz	128KB	0686h	FC-PGA	CO
Celeron 667	667MHz	66MHz	128KB	0683h	FC-PGA	BO
Celeron 633	633MHz	66MHz	128KB	0686h	FC-PGA	CO
Celeron 633	633MHz	66MHz	128KB	0683h	FC-PGA	BO
Celeron 600	600MHz	66MHz	128KB	0686h	FC-PGA	CO
Celeron 600	600MHz	66MHz	128KB	0683h	FC-PGA	BO
Celeron 566	566MHz	66MHz	128KB	068Ah	FC-PGA	DO
Celeron 566	566MHz	66MHz	128KB	0686h	FC-PGA	CO
Celeron 566	566MHz	66MHz	128KB	0683h	FC-PGA	BO
Celeron 533A	533MHz	66MHz	128KB	0683h	FC-PGA	BO
Celeron 533	533MHz	66MHz	128KB	0665h	PPGA	BO
Celeron 500	500MHz	66MHz	128KB	0665h	PPGA	BO
Celeron 466	466MHz	66MHz	128KB	0665h	PPGA	BO
Celeron 433	433MHz	66MHz	128KB	0665h	PPGA	BO
Celeron 400	400MHz	66MHz	128KB	0665h	PPGA	BO
Celeron 366	366MHz	66MHz	128KB	0665h	PPGA	BO
Celeron 333	333MHz	66MHz	128KB	0665h	PPGA	BO
Celeron 300A	300MHz	66MHz	128KB	0665h	PPGA	BO

Pentium-III® Processors Currently Supported (as of 05/2002)

Processor	Speed	Host Bus	L2 Cache	CPU ID	Package	Stepping
Pentium-III 1.13G	1.13GHz	133MHz ¹	256KB	068Ah	FC-PGA	D0
Pentium-III 1.1G	1.1GHz	100MHz	256KB	068Ah	FC-PGA	D0
Pentium-III 1BG	1GHz	133MHz ¹	256KB	068Ah	FC-PGA	D0
Pentium-III 1BG	1GHz	133MHz ¹	256KB	0686h	FC-PGA	C0
Pentium-III 1G	1GHz	100MHz	256KB	068Ah	FC-PGA	D0
Pentium-III 933	933MHz	133MHz ¹	256KB	068Ah	FC-PGA	D0
Pentium-III 933	933MHz	133MHz ¹	256KB	0686h	FC-PGA	C0
Pentium-III 933	933MHz	133MHz ¹	256KB	0683h	FC-PGA	B0
Pentium-III 900	900MHz	100MHz	256KB	068Ah	FC-PGA	D0
Pentium-III 900	900MHz	100MHz	256KB	0686h	FC-PGA	C0
Pentium-III 866	866MHz	133MHz ¹	256KB	068Ah	FC-PGA	D0
Pentium-III 866	866MHz	133MHz ¹	256KB	0686h	FC-PGA	C0
Pentium-III 866	866MHz	133MHz ¹	256KB	0683h	FC-PGA	B0
Pentium-III 850	850MHz	100MHz	256KB	068Ah	FC-PGA	D0
Pentium-III 850	850MHz	100MHz	256KB	0686h	FC-PGA	C0
Pentium-III 850	850MHz	100MHz	256KB	0683h	FC-PGA	B0
Pentium-III 800EB	800MHz	133MHz ¹	256KB	068Ah	FC-PGA	D0
Pentium-III 800EB	800MHz	133MHz ¹	256KB	0686h	FC-PGA	C0
Pentium-III 800EB	800MHz	133MHz ¹	256KB	0683h	FC-PGA	B0
Pentium-III 800EB	800MHz	133MHz ¹	256KB	0681h	FC-PGA	A2
Pentium-III 800	800MHz	100MHz	256KB	068Ah	FC-PGA	D0
Pentium-III 800	800MHz	100MHz	256KB	0686h	FC-PGA	C0
Pentium-III 800	800MHz	100MHz	256KB	0683h	FC-PGA	B0
Pentium-III 800	800MHz	100MHz	256KB	0681h	FC-PGA	A2
Pentium-III 750	750MHz	100MHz	256KB	068Ah	FC-PGA	D0
Pentium-III 750	750MHz	100MHz	256KB	0686h	FC-PGA	C0
Pentium-III 750	750MHz	100MHz	256KB	0683h	FC-PGA	B0
Pentium-III 750	750MHz	100MHz	256KB	0681h	FC-PGA	A2
Pentium-III 733	733MHz	133MHz ¹	256KB	068Ah	FC-PGA	D0
Pentium-III 733	733MHz	133MHz ¹	256KB	0686h	FC-PGA	C0
Pentium-III 733	733MHz	133MHz ¹	256KB	0683h	FC-PGA	B0
Pentium-III 733	733MHz	133MHz ¹	256KB	0681h	FC-PGA	A2

Pentium-III® Processors Currently Supported (as of 05/2002)

Processor	Speed	Host Bus	L2 Cache	CPU ID	Package	Stepping
Pentium-III 700	700MHz	100MHz	256KB	068Ah	FC-PGA	D0
Pentium-III 700	700MHz	100MHz	256KB	0686h	FC-PGA	C0
Pentium-III 700	700MHz	100MHz	256KB	0683h	FC-PGA	B0
Pentium-III 700	700MHz	100MHz	256KB	0681h	FC-PGA	A2
Pentium-III 667	667MHz	133MHz ¹	256KB	0686h	FC-PGA	C0
Pentium-III 667	667MHz	133MHz ¹	256KB	0683h	FC-PGA	B0
Pentium-III 667	667MHz	133MHz ¹	256KB	0681h	FC-PGA	A2
Pentium-III 650	650MHz	100MHz	256KB	0686h	FC-PGA	C0
Pentium-III 650	650MHz	100MHz	256KB	0683h	FC-PGA	B0
Pentium-III 650	650MHz	100MHz	256KB	0681h	FC-PGA	A2
Pentium-III 600EB	600MHz	133MHz ¹	256KB	0686h	FC-PGA	C0
Pentium-III 600EB	600MHz	133MHz ¹	256KB	0683h	FC-PGA	B0
Pentium-III 600EB	600MHz	133MHz ¹	256KB	0681h	FC-PGA	A2
Pentium-III 600E	600MHz	100MHz	256KB	0686h	FC-PGA	C0
Pentium-III 600E	600MHz	100MHz	256KB	0683h	FC-PGA	B0
Pentium-III 600E	600MHz	100MHz	256KB	0681h	FC-PGA	A2
Pentium-III 550E	550MHz	100MHz	256KB	0683h	FC-PGA	B0
Pentium-III 550E	550MHz	100MHz	256KB	0681h	FC-PGA	A2
Pentium-III 533EB	533MHz	133MHz ¹	256KB	0683h	FC-PGA	B0
Pentium-III 533EB	533MHz	133MHz ¹	256KB	0681h	FC-PGA	A2
Pentium-III 500E	500MHz	100MHz	256KB	0683h	FC-PGA	B0
Pentium-III 500E	500MHz	100MHz	256KB	0681h	FC-PGA	A2

¹ 133MHz host bus frequency supported only with 810E chipset

Thermal Considerations

In order to avoid malfunctioning of the CC8-BLUES, take care of appropriate cooling of the processor and system, e.g. by a cooling fan suitable to the maximum power consumption of the CPU chip actually in use. Please note, that the processors temperature is steadily measured by a special controller (MAX1617), attached to the onboard SMBus[®] (System Management Bus). The processor core (die) temperature is signalled by the forward voltage of a CPU integrated diode. A second diode internal to the MAX1617 allows for acquisition of the boards surface temperature. The programmable overtemperature alarm allows to trigger the SMBus alert line in order to avoid overheating. A suitable software to display both, the die temperature, as well as the board temperature, is MBM (Motherboard Monitor), which can be downloaded from the web. After installation, both temperatures can be observed permanently from the Windows taskbar.

By default, the CC8-BLUES is equipped with a passive heatsink, covering not only the processor chip itself but also major areas on the board, for an optimum thermal conduction. In addition, a forced vertical air flow trough the system enclosure (e.g. bottom mount fan unit) is strongly recommended. Be sure to thoroughly discuss your actual cooling needs with EKF. Generally, the faster the CPU speed the higher is its power consumption.

The maximum power consumption and operating temperature of a particular processor can be derived from the tables below. Fortunately, the power consumption is by far lower when executing typical Windows or Linux tasks. The heat dissipation increases especially when rendering software is executed, e.g. the Acrobat Distiller. EKF tests the CC8-BLUES by running 'kpower.exe', a proprietary Intel tool for generating the maximum stress to the processor.



Celeron® Processors Maximum Power Consumption and Die Temperature

Processor	Speed	Host Bus	CPU ID	maximum Power	max. Die Temperature
Celeron 1.1G	1.1GHz	100MHz	068Ah	33.0W	77°C
Celeron 1G	1GHz	100MHz	068Ah	29.0W	75°C
Celeron 950	950MHz	100MHz	068Ah	28.0W	79°C
Celeron 900	900MHz	100MHz	068Ah	26.7W	77°C
Celeron 850	850MHz	100MHz	068Ah	25.7W	80°C
Celeron 850	850MHz	100MHz	0686h	22.5W	80°C
Celeron 800	800MHz	100MHz	068Ah	24.5W	80°C
Celeron 800	800MHz	100MHz	0686h	20.8W	80°C
Celeron 766	766MHz	66MHz	068Ah	23.6W	80°C
Celeron 766	766MHz	66MHz	0686h	20.0W	80°C
Celeron 733	733MHz	66MHz	068Ah	22.8W	80°C
Celeron 733	733MHz	66MHz	0686h	19.1W	80°C
Celeron 700	700MHz	66MHz	0686h	21.9W	80°C
Celeron 700	700MHz	66MHz	0683h	18.3W	80°C
Celeron 667	667MHz	66MHz	0686h	21.1W	82°C
Celeron 667	667MHz	66MHz	0683h	17.5W	82°C
Celeron 633	633MHz	66MHz	0686h	20.2W	82°C
Celeron 633	633MHz	66MHz	0683h	16.5W	82°C
Celeron 600	600MHz	66MHz	0686h	19.6W	90°C
Celeron 600	600MHz	66MHz	0683h	15.8W	90°C
Celeron 566	566MHz	66MHz	068Ah	19.2W	90°C
Celeron 566	566MHz	66MHz	0686h	14.9W	90°C
Celeron 533A	533MHz	66MHz	0683h	14.0W	90°C
Celeron 533	533MHz	66MHz	0665h	28.3W	T_case 70°C
Celeron 500	500MHz	66MHz	0665h	27.0W	T_case 70°C
Celeron 466	466MHz	66MHz	0665h	25.6W	T_case 70°C
Celeron 433	433MHz	66MHz	0665h	24.1W	T_case 85°C
Celeron 400	400MHz	66MHz	0665h	23.7W	T_case 85°C
Celeron 366	366MHz	66MHz	0665h	21.7W	T_case 85°C
Celeron 333	333MHz	66MHz	0665h	19.7W	T_case 85°C

Pentium-III® Processors Maximum Power Consumption and Die Temperature

Processor	Speed	Host Bus	CPU ID	maximum Power	max. Die Temperature
Pentium-III 1.13G	1.13GHz	133MHz	068Ah		
Pentium-III 1.1G	1.1GHz	100MHz	068Ah		
Pentium-III 1BG	1GHz	133MHz	068Ah	29.0W	75°
Pentium-III 1BG	1GHz	133MHz	0686h	26.1W	70°
Pentium-III 1G	1GHz	100MHz	068Ah	29.0W	75°
Pentium-III 933	933MHz	133MHz	068Ah	27.5W	77°
Pentium-III 933	933MHz	133MHz	0686h	24.5W	77°
Pentium-III 900	900MHz	100MHz	068Ah	26.7W	77°
Pentium-III 900	900MHz	100MHz	0686h	23.2W	77°
Pentium-III 866	866MHz	133MHz	068Ah	26.1W	80°
Pentium-III 866	866MHz	133MHz	0686h	22.9W	80°
Pentium-III 850	850MHz	100MHz	068Ah	25.7W	80°
Pentium-III 850	850MHz	100MHz	0686h	22.5W	80°
Pentium-III 800EB	800MHz	133MHz	068Ah	24.5W	80°
Pentium-III 800EB	800MHz	133MHz	0686h	20.8W	80°
Pentium-III 800	800MHz	100MHz	068Ah	24.5W	80°
Pentium-III 800	800MHz	100MHz	0686h	20.8W	80°
Pentium-III 750	750MHz	100MHz	068Ah	23.2W	80°
Pentium-III 750	750MHz	100MHz	0686h	19.5W	80°
Pentium-III 733	733MHz	133MHz	068Ah	22.8W	80°
Pentium-III 733	733MHz	133MHz	0686h	19.1W	80°
Pentium-III 700	700MHz	100MHz	068Ah	21.9W	80°
Pentium-III 700	700MHz	100MHz	0686h	18.3W	80°
Pentium-III 667	667MHz	133MHz	0686h	17.5W	82°
Pentium-III 650	650MHz	100MHz	0686h	17.0W	82°
Pentium-III 600EB	600MHz	133MHz	0686h	15.8W	82°
Pentium-III 600E	600MHz	100MHz	0686h	15.8W	82°
Pentium-III 550E	550MHz	100MHz	0683h	14.5W	85°
Pentium-III 533EB	533MHz	133MHz	0683h	14.0W	85°
Pentium-III 500E	500MHz	100MHz	0683h	13.2W	85°

A special method to reduce power consumption is to force the processor into the 'Throttle Mode'. This is achieved by actuating the 'Stop Clock' input of the CPU, and can be activated through the BIOS settings. A Throttle Mode of 50% e.g. means a duty cycle of 50% on the stop clock input. However, while saving considerable power consumption, the data throughput of the processor is also reduced. The table below shows the effect of several throttle mode settings on the processor temperature in a given system equipped with the CC8-BLUES. The CPU is a 850MHz Pentium-III processor, the airflow around the CC8 cards slot is about 16m³/h, which is typical for EKF systems. While the testing procedure, the CPU is stressed to its maximum by running kpower.exe.

Ambient Temperature °C Climate Chamber	Throttle Mode (PIII-850) °C							
	0% (100% duty)		25%		50%		87.5%	
	Board	Die	Board	Die	Board	Die	Board	Die
40	52	74	50	68	48	60	42	48
45	59	82	58	75	54	66	50	54
50	64	87	64	82	60	72	55	58
55	71	93	69	86	66	77	61	63
60	76	98	74	91	71	82	65	67
65	81	104	79	96	76	87	71	72
70	87	110	84	102	81	92	76	78
75	92	115	89	107	87	98	80	81
80	97	119	95	112	92	103	85	86
85	1)	1)	100	117	97	108	90	92
90			1)	1)	102	113	95	97
95					108	119	101	102
100					1)	1)	106	107

1) System not operational anymore

From the table on the previous page the maximum allowed die temperature of the PIII-850 can be derived as 80°C. If a small amount of overtemperature would be tolerated, the test system can be operated up to 45°C ambient temperature at 0% throttle mode, and up to 75°C at 87.5% throttle mode. However, the processor under test did remain fully functional up to ~120°C die temperature. Under typical conditions (not executing kpower.exe), the heat dissipation of the CPU would be remarkable lower, thus increasing the maximum ambient temperature of the CC8-BLUES.

The table below shows the effect of several throttle mode settings on the processor temperature in a given system equipped with the CC8-BLUES, now provided with a 566MHz Celeron processor. Again, the airflow around the CC8 cards slot is about 16m³/h, which is typical for EKF systems, and as before, while the testing procedure, the CPU is stressed to its maximum by running kpower.exe.

Ambient Temperature °C Climate Chamber	Throttle Mode (Celeron-566) °C							
	0% (100% duty)		25%		50%		87.5%	
	Board	Die	Board	Die	Board	Die	Board	Die
40	48	66	48	62	46	56	42	43
45	56	74	54	69	51	61	48	49
50	61	80	59	74	57	67	52	53
55	66	85	64	78	62	72	58	59
60	71	90	69	83	67	77	63	64
65	76	97	74	88	72	82	68	69
70	82	104	81	97	77	87	72	74
75	88	109	86	101	82	92	78	80
80	94	117	92	109	87	98	84	85
85	98	121	96	115	93	104	88	90
90	1)	1)	103	121	98	110	94	95
95			1)	1)	103	115	99	99
100					108	121	104	106

1) System not operational anymore

The maximum allowed die temperature of the Celeron-566 can be derived as 90°C. The test system can be operated up to 60°C ambient temperature at 0% throttle mode (which is 100% duty cycle), and up to 85°C at 87.5% throttle mode. However, the processor under test did remain fully functional up to ~120°C die temperature. Under typical conditions (not executing kpower.exe), the heat dissipation of the CPU would be remarkable lower, thus increasing the maximum ambient temperature of the CC8-BLUES.

The measuring results in the table above are based on a forced vertical airflow of 16m³/h around each card slot in a fully equipped 19-inch system rack, achieved by three Papst 4312M fans operated at 12V. Under these conditions, the CC8 heatsink delivers a thermal resistance of about 1K/W.

What can be recommended as an optimum airflow? The table below shows the effect on the maximum allowable ambient temperature of our PIII-850 system at the specified maximum processor die temperature of 80°C. Again, the processor is stressed to its maximum power dissipation by running kpower.exe.

Fan Type Pabst x 3	Vertical Airflow around each Card Slot	Maximum Ambient Temp. @Throttle Mode			
		0%	25%	50%	87.5%
4312GL/6V	4m ³ /h	20°C	35°C	44°C	69°C
4312GL/12V	10m ³ /h	31°C	43°C	55°C	73°C
4312M/12V	16m ³ /h	42°C	48°C	57°C	74°C
4312-179/13.2V	27m ³ /h	43°C	50°C	60°C	75°C

As easily can be seen, increasing the airflow above 16m³/h has no significant effect on the maximum allowable ambient temperature. So ~16m³/h would be the optimum airflow for most industrial systems.

Conclusion

Take care of sufficient heat exchange in your system. If appropriate, setup the Throttle Mode feature. Both Celeron and Pentium-III processors can be reliably operated over a wide temperature range in a suitable environment.

Main Memory

The CC8-BLUES is equipped with a socket for installing a single 144-pin SO-DIMM module (module height limited to ≤ 1.100 inch). Minimum memory size is 32MB; maximum memory size is 256MB. Due to the video requirements of the i810 chipset, minimum memory for the Windows NT 4.0 and Windows 2000 operating system is 64MB (some of the system memory is dedicated to the graphics controller). The supported on-board memory is entirely cacheable. The memory module is a unbuffered SD-RAM, PC100 style. The contents of the SPD eeprom are displayed on system start by the BIOS. The memory clock is 100MHz maximum, due to limitations of the 810GMCH.

LAN Subsystem

The Intel 82559ER Fast Ethernet PCI LAN subsystem provides both 10Base-T and 100Base-TX connectivity. Features include:

- PCI bus mastering 32-bit, 33MHz
- Shared memory structure in the host memory that copies data directly to/from host memory
- 10Base-T (Ethernet) and 100Base-TX (Fast Ethernet, half- or full-duplex) capability using a single RJ-45 connector
- IEEE 802.3 μ Auto-Negotiation for the fastest available connection
- Jumperless configuration (complete software-configurable)

Two display LEDs in the RJ-45 connector signal LAN Link and Activity status.

The Intel 82559ER Fast Ethernet PCI LAN software and drivers are available from Intel's World Wide Web site.

Enhanced IDE Interface

The EIDE interface handles the exchange of information between the processor and ATA CompactFlash cards (including IBM MicroDrives).

The primary IDE interface is not in use on the CC8-BLUES. The secondary IDE interface is routed to the CompactFlash Card Adapter socket. Use this connector to attach a CompactFlash ATA style silicon disk or miniature drive, whenever an on-board mass storage device is needed for your application.

It is possible, to boot the operation system from the CompactFlash card. While being a simple task to install Linux on the CC8-BLUES, there are some issues to observe regarding Windows 2000.

A display LED, situated in the front panel near the reset push-button, signals the disk activity status of the IDE device (the CompactFlash slot). This LED is also software programmable. See the section "Programmable LED" how to do this.

Graphics Subsystem

The graphics subsystem is part of the Intel 82810 Graphic/Memory Controller Hub (GMCH), supporting the following features:

- 3-D Hyper Pipelined architecture
- Full 2-D hardware acceleration
- Motion video acceleration
- 3-D graphics visual and texturing enhancements
- Integrated 24-bit 230MHz RAMDAC
- DDC2B compliant
- Hardware motion compensation for software MPEG2 decode
- Integrated graphics memory controller

Due to lack of space on the front panel, the CC8-BLUES is provided with a miniature 10-lead female *Har-Link* metric connector. A short adapter cable (not supplied with the CC8-BLUES) is available as accessory for converting the video output signals to the popular 15-pin HD-SUB VGA connector.



CC8-BLUES Video Adapter Cable

i810 GMCH Refresh Rates						
Resolution	Color	60Hz	70Hz	72Hz	75Hz	85Hz
640x200	16		!			
640x350	16		!			
640x400	256	!	!		!	!
	64K	!	!		!	!
	16M		!			
640x480	16	!		!	!	!
	256	!	!	!	!	!
	32K	!			!	!
	64K	!	!	!	!	!
	16M	!	!	!	!	!
800x600	256	!	!	!	!	!
	32K	!			!	!
	64K	!	!	!	!	!
	16M	!	!	!	!	!
1024x768	256	!	!		!	!
	32K	!			!	!
	64K	!	!	!	!	!
	16M	!	!	!	!	!
1056x800	16		!			
1280x1024	256	!	!	!	!	!
	32K	!			!	!
	64K	!	!	!	!	!
	16M	!	!	!	!	!

Universal Serial Bus (USB)

The CS5-BLUES is provided with a single USB port, routed to a front panel connector. You can connect a USB peripheral device directly to the CC8 without an external hub. To attach more devices, connect an external hub to the CC8 built-in port (often monitors or keyboards provide USB hub functionality). The USB connector can source up to 0.5A/5V, and is protected by an electronic power switch against shortening.

IEEE 1394 / FireWire High Performance Serial Bus

The CC8-BLUES is equipped with an integrated 1394a-2000 OHCI PHY/Link-Layer Controller. This standard defines a maximum data transfer rate of 400Mbps. The dual port PHY acts as a 1394 hub with respect to the 1394 receptacles in the front panel. The 6-lead connectors with integrated power distribution can source up to 0.5A/10V in total to remote devices, and are protected by an electronic regulator against short-circuit conditions.

Real-Time Clock

The CC8-BLUES has a time-of-day clock and 100-year calendar. A battery on the board keeps the clock current when the computer is turned off. The CC8 uses a Vanadium-Pentoxide-Lithium rechargeable battery, giving an autonomy of more than 80 days when fully loaded after 24 hours. The cell is free of memory effects and withstands deep discharging. Under normal conditions, replacement should be superfluous during lifetime of the board.

LPC Super- I/O Interface

In a modern system, legacy ports as PS/2 Keyboard/Mouse, COM1/2 and LPT have been replaced by USB and Ethernet connectivity. The 1.4MB floppy disk drive has been swapped against LS-120 or CD-RW drives, attached to the IDE connector. Hence, the CC8-BLUES is virtually provided with all necessary I/O ports.

Though, for applications with inevitable demand for legacy I/O, EKF offers the CC6-ACID, an expansion module to the CC8-BLUES, featuring all classic Super-I/O functionality. The CC6-ACID is a 3U Eurocard, with an either 8HP (double) or 4HP (single) width front panel. Access to the connectors COM1/2, LPT, mouse, keyboard is given directly from the front panel. Onboard connectors are provided for FDD, MIDI/Gameport, and cooling fans. The CC6-ACID connects to the CC8-BLUES across the connector LPCT or LPCB (LPC = Low Pin Count interface standard). The CC6-ACID can be attached either to the top of the CC8-BLUES or to the bottom (bottom attachment restricted to the 4HP version of the CC6-ACID).



The (similar) photo above (left) shows the bottom attachment of the CC6-ACID. The boards are fixed together by the LPC connector and the IDE connector, and in addition by a bracket which bolts together both front panels. The (similar) right image shows the top attachment of the CC6-ACID.



The photo above (left) shows the CC8-BLUES and CC6-ACID connected by the LPC interface. The right image shows the front panel fixing bracket.

Watchdog/Reset

The CC8-BLUES is provided with the MAX705 supervisor circuit, which controls the supply voltages 3.3V, 5V and the CPU core voltage, and generates a power-on reset signal. The manual push-button reset is also passed through the MAX705 for appropriate pulse conditioning.

The reset manual push-button is situated at the front panel. The button is indent mounted behind the front and requires a tool, e.g. pen to be pressed, preventing from being inadvertently activated. The push button reset signal is routed across a PLD (programmable logic device) and could be passivated on customers request.

The healthy state of the CC8-BLUES is signalled by the LED PWR integrated into the reset push-button. As soon as this LED begins to shine all power voltages are well and the reset signal was deasserted.

Another feature is the watchdog function, which can be programmed by software. The behaviour of the MAX705 watchdog is partially defined by the PLD, which controls whether the watchdog is activated. The related software (e.g. BIOS, application program) must trigger the watchdog by toggling the GPIO21 signal of the ICH 82801.

The watchdog is in a passive state after a system reset. There is no need to trigger it at boot time. Once the GPIO21 of the ICH was pulsed the watchdog is activated. If the duration between two trigger pulses exceeds a period of 1000 ms the watchdog timed out and a system reset is generated.

The watchdog remains in the active state until the next system reset. There is no way to disable it once it was started.

Firmware Hub (Flash BIOS)

The BIOS is stored in the 82802Ax Firmware Hub (there are second sources available with deviant part numbers). The firmware hub contains a nonvolatile memory core based on flash technology, allowing the BIOS to be upgraded. Currently, there are three variants of the FWH available:

x = A: 2Mbit

x = B: 4Mbit

x = C: 8Mbit

The FWH is soldered at the bottom side of the CC8-BLUES. Be careful when upgrading to a new BIOS - a failure while re-programming the flash (e.g. by power interruption) can cause the board to become no more operable. You would have to send in the board to EKF for repair.

The latest CC8-BLUES BIOS release (including a suitable programming tool) is available from the EKF website.

Programmable LED

The CC8-BLUES offers a software programmable LED, marked as IDE (placed near the reset push-button). After system reset, this LED defaults to signal the IDE activity. By the first setting of the GPIO22 of the ICH 82801 this LED changes its function and is then controlled only by the level of the GPIO22 pin. Setting this pin to 1 will switch on the LED.

The LED IDE remains in the programmable state until the next system reset.

Non-Transparent PCI Bridge

Unlike the VMEbus, the CompactPCI bus was not designed for multiple processor boards which share a common backplane. Instead, (only) one system slot controller (CPU board) has been defined; all other card slots are reserved for peripheral I/O boards. In order to achieve multi-processing, additional CPU boards on the CPCI bus must hide themselves behind a so called non-transparent PCI bridge. This is what mainly distinguishes the CC8-BLUES from system slot controllers such as the CC7-JAZZ, which is provided with a transparent PCI bridge.

The CC8-BLUES is equipped with a 21555 non-transparent PCI bridge. The Intel® 21555 is a PCI peripheral device that performs PCI bridging functions for embedded and intelligent I/O applications. The 21555 has a 64-bit primary interface, a 64-bit secondary interface, and 66-MHz capability. The 21555 is a "non-transparent" PCI-to-PCI bridge that acts as a gateway to an intelligent subsystem. It allows a local processor to independently configure and control the local subsystem. The 21555 implements an I²O message unit that enables any local processor to function as an intelligent I/O processor (IOP) in an I²O-capable system. Since the 21555 is architecture independent, it works with any host and local processors that support a PCI bus. Unlike a transparent PCI-to-PCI bridge, the 21555 is specifically designed to bridge between two processor domains. The processor domain on the primary interface of the 21555 is also referred to as the host domain, and its processor is the host processor. The secondary bus interfaces to the local domain and the local processor. Special features include support of independent primary and secondary PCI clocks, independent primary and secondary address spaces, and address translation between the primary (host) and secondary (local) domains. The 21555 uses a Type 0 configuration header, which presents the entire subsystem as a single "device" to the host processor. This allows loading of a single device driver for the entire subsystem, and independent local processor initialization and control of the subsystem devices. Since the 21555 uses a Type 0 configuration header, it does not require hierarchical PCI-to-PCI bridge configuration code. The 21555 forwards transactions between the primary and secondary PCI buses as does a transparent PCI-to-PCI bridge. In contrast to a transparent PCI-to-PCI bridge, the 21555 can translate the address of a forwarded transaction from a system address to a local address, or vice versa. This mechanism allows the 21555 to hide subsystem resources from the host processor and to resolve any resource conflicts that may exist between the host and local subsystems.

The 21555 is functionally similar to a transparent PCI-to-PCI bridge (PPB) in that both provide a connection path between devices attached to two independent PCI buses. A 21555 and a PPB allow the electrical loading of devices on one PCI bus to be isolated from the other bus while permitting concurrent operation on both buses. Since the *PCI Local Bus Specification* restricts PCI option cards to a single electrical load, the ability of PPBs and the 21555 to spawn PCI buses enables the design of multi device PCI option cards. The key difference between a PPB and the 21555 is that the presence of a PPB in a connection path between the host processor and a device is transparent to devices and device drivers, while the presence of the 21555 is not. This difference enables the 21555 to provide features that better support the use of intelligent controllers in the subsystem such as the CC8-BLUES. A primary goal of the PCI-to-PCI bridge architecture was that a PPB be transparent to devices and device drivers. For example, no changes are needed to a device driver when a PCI peripheral is located behind a PPB. Once configured during system initialization, a PPB operates without the aid of a device driver. A PPB does not require a device driver of its own since it does not have any resources that must be managed by software during run-time. This requirement for transparency forced the usage of a

flat addressing model across PCI-to-PCI bridges. This means that a given physical address exists at only one location in the PCI bus hierarchy and that this location may be accessed by any device attached at any point in the PCI bus hierarchy. As a consequence, it is not possible for a PPB to isolate devices or address ranges from access by devices on the opposite interface of a PPB. The PPB architecture assumes that the resources of any device in a PCI system are configured and managed by the host processor.

Since the 21555 is not transparent, the device driver for the CC8-BLUES must be aware of the presence of the 21555 and manage its resources appropriately. The 21555 allows the entire subsystem to appear as a single virtual device to the host. This enables configuration software to identify the appropriate driver for the subsystem.

Hot Swap Controller

The CC8-BLUES is provided with a Hot Swap controlling mechanism according to the PICMG 2.1 R2.0 specification. Hot Swap defines a process for installing and removing boards without adversely effecting a running system. Since the CC8-BLUES was designed with cluster-computing in mind, it was important to allow hot-plugging of the board.

The CC8-BLUES is equipped with the MIC2580 Hot Swap Controller. The MIC2580 provides for safe and orderly insertion and removal of the CC8-BLUES from a hot-plug compliant CompactPCI system. The MIC2580 incorporates a circuit breaker function that protects all four supplies (+12V, +5V, +3.3V, and -12V) upon an overcurrent fault condition. Current foldback limiting prevents large transient currents caused by plugging adapter cards into live backplanes, such as in a CompactPCI system. A slew-rate control limits high inrush currents to all loads that occur when power is applied to large capacitive loads. Voltage supervisory functions for all four power supplies are provided.

Geographic Addressing Lines GA0..GA2

The CC8-BLUES supports geographic addressing. The signals GA0..GA2 are routed from the CPCI connector J2 to the GPIO ports of the 82801AA (ICH).

<i>CompactPCI</i> Geographic Addressing		
J2 E22	GA0	GPIO 8
J2 D22	GA1	GPIO 13
J2 C22	GA2	GPIO 12

Installing and Replacing Components

Before You Begin

Warnings

The procedures in this chapter assume familiarity with the general terminology associated with industrial electronics and with safety practices and regulatory compliance required for using and modifying electronic equipment. telecommunication links, networks or procedures described in this chapter. links before you open the system or personal injury or equipment damage. operate even though the power switch is in its off state.



Disconnect the system from any modems before performing any of the Failure to disconnect telecommunication perform any procedures can result in Some parts of the system can continue to

Do not expose the board to fire. Battery and cause personal injury.



cells and other components could explode

Caution

Electrostatic discharge (ESD) can damage components. Perform the procedures described in this chapter only at an ESD workstation. If provide some ESD protection by wearing to a metal part of the system chassis or in its original ESD protected packaging.



such a station is not available, you can an antistatic wrist strap and attaching it board front panel. Store the board only Retain the original packaging (antistatic bag and antistatic box) in case of returning the board to EKF for rapair.

Installing the Board

Board insertion may be done in a running *CompactPCI* system. Typically you will perform the following steps:

- Attach your antistatic wrist strap to a metallic part of the system.
- Remove the board packaging, be sure to touch the board only at the front panel.
- Identify the related *CompactPCI* slot (peripheral slot for I/O boards, system slot for CPU boards, with the system slot typically most right or most left to the backplane).
- Insert board carefully and push it slowly over the guide rails, but do not contact it with any backplane connectors. Be sure not to damage components mounted on the bottom side of the board by scratching neighbored front panels.
- Attach any necessary cabling to the board's front panel and onboard connectors.
- Press the board into the backplane connectors by the ejector lever(s) until the lever locks. The blue hot swap LED illuminates during this process.
- Retain original packaging in case of return.

Removing the Board

Board extraction may be done from a running *CompactPCI* system. Typically you will perform the following steps:

- Attach your antistatic wrist strap to a metallic part of the system.
- Identify the board, be sure to touch the board only at the front panel.
- Unlock the ejector lever.
- As soon as the blue hot swap LED illuminates, activate the ejector lever to pull the *CompactPCI* connectors out of the backplane. ¹⁾
- Remove any front panel and onboard cabling assembly.
- Remove the board carefully. Be sure not to damage components mounted on the bottom side of the board by scratching neighbored front panels.
- Store board in the original packaging, do not touch any components, hold the board at the front panel only.

Note ¹⁾ :

To wait for the LED to illuminate is not necessary when extracting the board from a powerless system.

EMC Recommendations



In order to comply with the CE regulations for EMC, it is mandatory to observe the following rules:

- The chassis or rack including other boards in use must comply entirely with CE
- Close all board slots not in use with a blind front panel
- Front panels must be fastened by built-in screws
- Cover any unused front panel mounted connector with a shielding cap
- External communications cable assemblies must be shielded (shield connected only at one end of the cable)
- Use ferrite beads for cabling wherever appropriate
- Some connectors may require additional isolating parts

Reccomended Accessories

Blind CPCI Front Panels	EKF Elektronik	Widths currently available (1HP=5.08mm): with handle 4HP/8HP without handle 2HP/4HP/8HP/10HP/12HP
Ferrit Bead Filters	ARP Datacom, 63115 Dietzenbach	Ordering No. 102 820 (cable diameter 6.5mm) 102 821 (cable diameter 10.0mm) 102 822 (cable diameter 13.0mm)
Metal Shielding Caps	Conec-Polytronic, 59557 Lippstadt	Ordering No. CDFA 09 165 X 13129 X (DB9) CDSFA 15 165 X 12979 X (DB15) CDSFA 25 165 X 12989 X (DB25)

Installing or Replacing the Processor

Note: If you decide to install a processor on your own, observe the precautions in 'Before You Begin'

As default, the CC8-BLUES comes fully equipped and tested with a processor. So normally there should be no need to install a processor.

Due to the very compact construction of the CC8-BLUES, a ZIF socket for the processor could not be implemented. Instead, the CC8 features a high quality industrial PGA 370 socket with precision contacts. You will need a special tool to remove the processor from this socket. If you try to remove the CPU without the PGA extracting tool, the processor's case or its contact pins could be damaged. We suggest that you install or replace the processor only if you own an ESD workstation and the matching extracting tool.

Before the processor can be replaced, you would have to remove the passive heatsink, which is fitted by screws to the board and attached by conductive pads and/or adhesion to the processor. Special handling is required to remove the heatsink and to re-install it afterwards, including renewing the conductive adhesion and adjustment of the mounting screws.

Conclusion: Do not attempt to replace the processor by yourself, unless you are an absolute professional. Instead, send in the board to EKF.

Installing or Replacing the Memory Module

Note: If you decide to replace the memory, observe the precautions in 'Before You Begin'

By default, the CC8-BLUES comes fully equipped and tested with a 64MB...256MB SD-RAM memory module. So normally there should be no need to install a memory module.

Because the main memory is also used as video memory, the CC8-BLUES requires a PC-100 (100MHz) SDRAM SO-DIMM module even when the processor front side bus is 66MHz (Celeron only). It is highly recommended that Serial Presence Detect (SPD) SO-DIMMs be used, since this allows the chipset to accurately configure the memory settings for optimum performance. If non-SPD memory is installed, the BIOS will attempt to correctly configure the memory settings, but performance and reliability may be impacted.

A replacement memory module must match the 144-pin SO-DIMM form factor (known from Notebook PCs), 3.3V, 100MHz unbuffered, non-ECC style. Be sure to buy no module with a height >1.100 inch. Suitable modules are available up to 256MB. The 810GMCH supports modules of up to a maximum of 12 address lines (A0...A11). However, there are also 256MB memory modules on the market organized by 13 address lines, which are not suitable.

Conclusion: Replacement of a memory module is easy, but unnecessary in most cases.

Replacement of the Battery

When your system is turned off, a battery maintains the current time-of-day clock and the values in CMOS RAM current. The battery is rechargeable und should last during the lifetime of the CC8-BLUES. For replacement, the old battery must be desoldered, and the new one soldered. Observe the cell polarization. We suggest that you send back the board to EKF for battery replacement.

Warning

Danger of explosion if the battery is incorrectly replaced. Replace only with the same or equivalent type. Do not expose a battery to fire.



Technical Reference

Local PCI Devices

The following table shows the on-board PCI devices and their location within the PCI configuration space. These devices consist of the Ethernet controller, the PCI-To-PCI Bridge and several devices within the i810 chip set.

Bus Number	Device Number	Function Number	Vendor ID	Device ID	Description
0	0x00	0	0x8086	0x7120 ¹⁾	Host Bridge
0	0x01	0	0x8086	0x7121 ²⁾	VGA Display
0	0x1E	0	0x8086	0x2418	PCI-To-PCI Bridge
0	0x1F	0	0x8086	0x2410	ISA Bridge
0	0x1F	1	0x8086	0x2411	IDE Controller
0	0x1F	2	0x8086	0x2412	USB Controller
0	0x1F	3	0x8086	0x2413	SMB Controller
1	0x04	0	0x8086	0x1209	Ethernet Controller
1	0x05	0	0x104C	0x8021	IEEE 1394 OHCI Controller
1	0x06	0	0x8086	0xB555	PCI-To-PCI Bridge (CPCI)

¹⁾ 0x7122 when i810E chipset is stuffed

²⁾ 0x7123 when i810E chipset is stuffed

Local SMB Devices

The CC8-BLUES contains a few devices that are reachable via the System Management Bus (SMB). These are the clock generation chip, the SPD EEPROM on the SO-DIMM memory module and a CPU temperature controlling device in particular. Other devices could be connected to the SMB via the *CompactPCI* signals IPMB SCL (J1 B17) and IPMB SDA (J1 C17).

Address	Description
0x30	CPU Temperature Sensor MAX 1617
0xA0	SPD of SO-DIMM
0xD2	Main Clock Generation ICS 9250-16

Connectors

Caution

Some of the internal connectors provide operating voltage (e.g. 5V and 12V) to devices inside the system chassis, such as fans and internal peripherals. Not all of these connectors are overcurrent protected. Do not use these internal connectors for powering devices external to the computer chassis. A fault in the load presented by the external devices could cause damage to the board, the interconnecting cable and the external devices themselves.

Front Panel Connectors

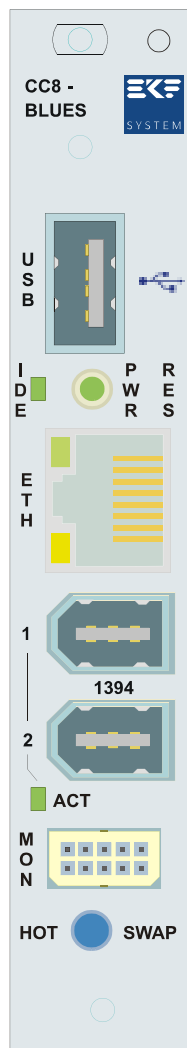

CC8-BLUES Front Panel Elements

Video Monitor Connector MON

Connector MON (Harting <i>Har-Link</i> Series No. 27 21 121 8000)	
<i>har-link</i> 10-lead female connector	VGA Signal
a 1	GND (blue return)
a 2	blue
b 1	GND (green return)
b 2	green
c 1	GND (red return)
c 2	red
d 1	GND (vsync return)
d 2	GND (hsync return)
e 1	vsync
e 2	hsync
metal case	shield

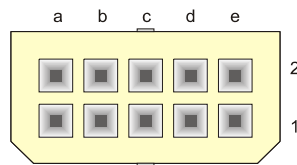

For attachment of an analog RGB monitor to the CC8-BLUES MON receptacle, there is an VGA adapter cable available as accessory. The table below shows the interconnections required:

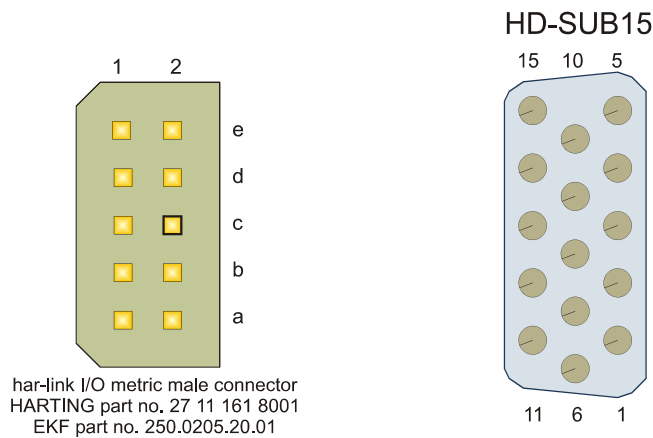

EKF VGA Adapter Cable Part No. 250.0205.30.03

<i>har-link</i> 27 11 161 8001 male connector	VGA Signal	Wire Pair each pair individually shielded	HD-SUB 15 female connector metal shell UNC 4-40 nuts
a 1	GND (blue return)	A	6
a 2	blue	A	3
b 1	GND (green return)	B	7
b 2	green	B	2
c 1	GND (red return)	C	8
c 2	red	C	1
d 1	GND (vsync return)	D	10
d 2	GND (hsync return)	E	5
e 1	vsync	D	14
e 2	hsync	E	13
metal case	shield		metal case

each wire pair individually shielded, in addition to common shield



CC8-BLUES Video Adapter Cable

USB Connector

USB	
1	+5V (Electronic Power Switch 0.5A)
2	USB Data 0 (1) NEG
3	USB Data 0 (1) POS
4	GND

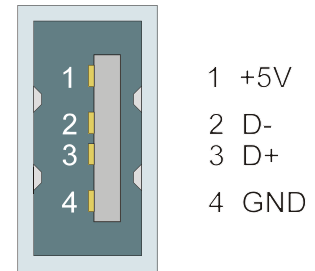

The connector is an USB A-style receptacle. Use any common USB cable for attachment of USB devices. The board is protected against devices with high power-on current or short circuit conditions across the USB cable by an electronic switch, which limits the maximum USB supply current to 0.5A nominal.

Ethernet Connector

RJ45	
1	TX+
2	TX-
3	RX+
4	
5	
6	RX-
7	
8	

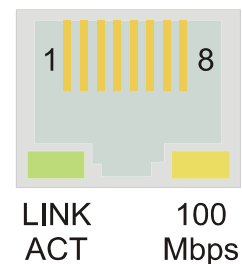

The yellow LED signals 100Mbit/s when lit, and 10Mbit/s when off. The green LED indicates LINK established when continuously on, and data transfer (activity) when blinking. If the green LED is off, no LINK is established.

IEEE 1394 / FireWire Connectors

Both 1394 receptacles are functionally equivalent and wired to a dual-port 1394 PHY, which is operated as a hub with respect to the connectors. 1394 bus power is sourced by the CC8-BLUES and electronically limited to $\sim 0.5A$ in total. Use commercially available cable assemblies to attach 1394 devices, which may have 4-position (without power distribution) or 6-position (with power distribution) receptacles.

The 1394 connectors are protruding through the CC8-BLUES front panel. This allows for snapping in a locking mechanism, which is part of special 1394 plugs for industrial use.

1394 (1 & 2)	
1	Bus Power
2	GND
3	TP B-
4	TP B+
5	TP A-
6	TP A+

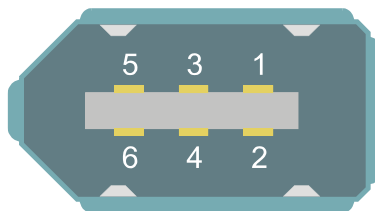

Avoid hot inserting of devices with high power-on current ($> 1A$) across the 1394 cable. EKF has found 1394 hard disk drives with a power-up current requirement beyond 1A, which may trigger the CC8-BLUES on-board 12V power switch protection circuit while hot insertion. This effect causes the board to be reset. As a workaround, power up such devices simultaneously with the CC8-BLUES, or use an external power supply for the respective 1394 device.

Internal Connectors

ATA CompactFlash Socket

CompactFlash Socket CFA1 (True IDE Mode)			
<i>CD1#</i>	26	1	GND
D11	27	2	D03
D12	28	3	D04
D13	29	4	D05
D14	30	5	D06
D15	31	6	D07
CS1#	32	7	CS0#
VS1# (10k PU)	33	8	A10 (GND)
IORD#	34	9	ATA_SEL# (GND)
IORW#	35	10	A09 (GND)
WE# (Vcc)	36	11	A08 (GND)
INTRQ (IRQ15)	37	12	A07 (GND)
Vcc	38	13	Vcc
CSEL# (GND)	39	14	A06 (GND)
VS2# (10k PU)	40	15	A05 (GND)
RESET#	41	16	A04 (GND)
IORDY	42	17	A03 (GND)
<i>INPACK#</i>	43	18	A02
REG# (Vcc)	44	19	A01
<i>DASP#</i>	45	20	A00
<i>PDIAG#</i>	46	21	D00
D08	47	22	D01
D09	48	23	D02
D10	49	24	IOCS16#
GND	50	25	<i>CD2#</i>

italic/gray - not connected

The CompactFlash specification 1.4 describes three different operating modes. The CC8-BLUES supports the True IDE mode only. Any CompactFlash Storage Card is required to support the True IDE mode and can be used on the CC8-BLUES.

LPC Low Pin Count Header

PLPCT/PLPCB			
GND	1	2	pciclk
GND	3	4	lad0
GND	5	6	lad1
GND	7	8	lad2
GND	9	10	lad3
GND	11	12	lframe#
GND	13	14	ldrq#
serirq	15	16	lpme#
lsmi#	17	18	pcirst#
5V	19	20	3.3V
rcin#	21	22	a20gate
12V	23	24	3.3V
sio_clk14	25	26	speaker

The LPC header is available twice, on both sides of the board, top and bottom, in order to provide attachment of the CC6-ACID either to the left or to the right side of the CC8-BLUES.

Fan Heatsink Pin Row

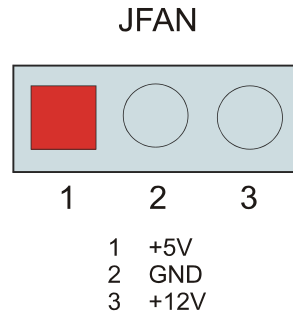

Speaker Pin Row

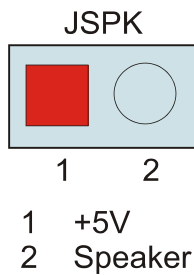

PLD Programming Pin Row

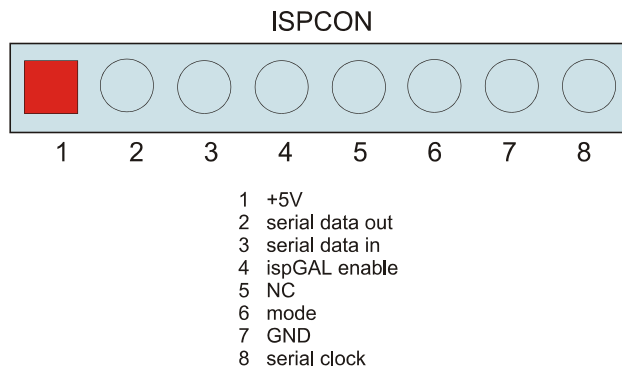

Note: The ISPCON is not normally stuffed. Its footprint is situated at the bottom side of the board.

Hot Swap Micro Switch Pin Row

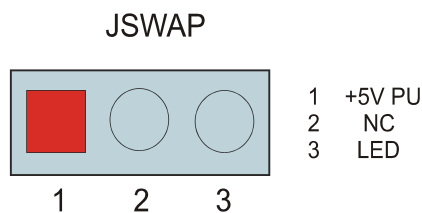

Processor Debug Header

PITP			
itpres#	1	2	GND
dbreset#	3	4	GND
tck	5	6	GND
tms	7	8	tdi
itppon	9	10	tdo
	11	12	trst#
GND	13	14	
GND	15	16	itpreq#
GND	17	18	itprdy#
GND	19	20	
GND	21	22	
GND	23	24	
GND	25	26	
GND	27	28	
itpclk	29	30	

Note: The Debug Header is not normally stuffed. Its footprint is situated at the bottom side of the board.

CompactPCI J1

#J1	A	B	C	D	E
25	5V	<i>REQ64#</i>	ENUM#	3.3V	5V
24	AD1	5V	VI/O ¹⁾	AD0	ACK64#
23	3.3V	AD4	AD3	5V ¹⁾	AD2
22	AD7	GND	3.3V ¹⁾	AD6	AD5
21	3.3V	AD9	AD8	M66EN	C/BE0#
20	AD12	GND	VI/O	AD11	AD10
19	3.3V	AD15	AD14	GND	AD13
18	SERR#	GND	3.3V	PAR	C/BE1#
17	3.3V	<i>IPMB SCL</i>	<i>IPMB SDA</i>	GND	PERR#
16	DEVSEL#	GND	VI/O	STOP#	LOCK#
15	3.3V	FRAME#	IRDY#	BDSSEL# ²⁾	TRDY#
14					
13					
12					
11	AD18	AD17	AD16	GND	C/BE2#
10	AD21	GND	3.3V	AD20	AD19
9	C/BE3#	IDSEL ²⁾	AD23	GND	AD22
8	AD26	GND	VI/O	AD25	AD24
7	AD30	AD29	AD28	GND	AD27
6	REQ#	GND	3.3V ¹⁾	CLK	AD31
5	<i>BRSVP1A5</i>	<i>BRSVP1B5</i>	RST#	GND	GNT#
4	<i>IPMB PWR</i>	HEALTHY#	VI/O ¹⁾	<i>INTP</i>	<i>INTS</i>
3	INTA#	<i>INTB#</i>	<i>INTC#</i>	5V ¹⁾	<i>INTD#</i>
2	<i>TCK</i>	5V	<i>TMS</i>	<i>TDO</i>	<i>TDI</i>
1	5V	-12V	<i>TRST#</i>	+12V	5V

pin positions printed italic/coloured brown: not connected

pin positions printed italic/coloured blue: not connected

Notes:

¹⁾ This is a long pin providing an early connection on hot board insertion.

²⁾ This is a short pin providing the last connection on hot board insertion.

CompactPCI J2

#J2	A	B	C	D	E
22	<i>GA4</i>	<i>GA3</i>	GA2	GA1	GA0
21	CLK6	GND	<i>RSV</i>	<i>RSV</i>	<i>RSV</i>
20	CLK5	GND	<i>RSV</i>	GND	<i>RSV</i>
19	GND	GND	<i>RSV</i>	<i>RSV</i>	<i>RSV</i>
18	<i>BRSVP2A18</i>	<i>BRSVP2B18</i>	<i>BRSVP2C18</i>	GND	<i>BRSVP2E18</i>
17	<i>BRSVP2A17</i>	GND	<i>PRST#</i>	<i>REQ6#</i>	<i>GNT6#</i>
16	<i>BRSVP2A16</i>	<i>PXI TRIG0</i>	<i>DEG#</i>	GND	<i>PXI TRIG7</i>
15	<i>BRSVP2A15</i>	GND	<i>FAL#</i>	<i>REQ5#</i>	<i>GNT5#</i>
14	AD35	AD34	AD33	GND	AD32
13	AD38	GND	V(I/O)	AD37	AD36
12	AD42	AD41	AD40	GND	AD39
11	AD45	GND	V(I/O)	AD44	AD43
10	AD49	AD48	AD47	GND	AD46
9	AD52	GND	V(I/O)	AD51	AD50
8	AD56	AD55	AD54	GND	AD53
7	AD59	GND	V(I/O)	AD58	AD57
6	AD63	AD62	AD61	GND	AD60
5	C/BE5#	64EN#	V(I/O)	C/BE4#	PAR64
4	V(I/O)	<i>BRSVP2B4</i>	C/BE7#	GND	C/BE6#
3	<i>CLK4</i>	GND	<i>GNT3#</i>	<i>REQ4#</i>	<i>GNT4#</i>
2	<i>CLK2</i>	<i>CLK3</i>	SYSEN#	<i>GNT2#</i>	<i>REQ3#</i>
1	<i>CLK1</i>	GND	<i>REQ1#</i>	<i>GNT1#</i>	<i>REQ2#</i>

pin positions printed italic/coloured brown: not connected

Power Supply Requirements

Operating Voltage	max. current (depends on CPU in use)
+5V / $\pm 0,25V$	7.0A
+3,3V / $\pm 0,1V$	3.5A
+12V / $\pm 0,5V$	0.5A
-12V / $\pm 0,5V$	-

Literature

Theme	Document Title	Origin
<i>CompactPCI</i> Specification	<i>CompactPCI</i> Specification, PICMG 2.0 R3.0, Oct. 1, 1999	PICMG (http://www.picmg.org)
<i>CompactPCI</i> Hot Swap	<i>CompactPCI</i> Hot Swap Specification, PICMG 2.1 R2.0, Jan. 17, 2001	PICMG (http://www.picmg.org)
USB Specification	Universal Serial Bus Specification	http://www.teleport.com/~usb
1394 Specification	High Performance Serial Bus Specification	http://standards.ieee.org
CompactFlash Specification	CompactFlash Specification R1.4	http://www.compactflash.org
PCI	PCI Hardware and Software Architecture & Design, Solari/Willse, 4th Edition, Annabooks	Annabooks (http://www.annabooks.com)
Metric Connectors	IEC 1076-4-101 Application Literature from ERNI, AMP, FCI	Beuth Verlag, Berlin ILI Index House, GB SL57EU Ascot Berkshire

EKF Elektronik GmbH
Philipp-Reis-Str. 4
D-59065 HAMM
(Germany)



Internet <http://www.ekf.de>
Fax. +49 (0)2381/6890-90
Tel. +49 (0)2381/6890-0
E-Mail info@ekf.de