

Estate Swing GSM Intercom and Access Control System



Web Direct Brands, Inc., parent corporation of Estate Swing, warrants all parts of the Estate Swing GSM Intercom / Access Control System for a period of 1 year from the date of purchase. The warranty applies to the original purchaser and is non-transferable.

The warranty applies only to defects in components and workmanship and NOT to damage due to causes beyond the control of Estate Swing; such as but not limited to incorrect voltage, lightning damage, mechanical shock, water damage, fire damage, damage arising out of abuse and improper application of the equipment, or any acts of nature.

To address a warranty issue please call 1-800-640-4283 between 9-5 EST M-F to receive technical assistance and if deemed needed an RA number from a technician to send the product or component in for evaluation. All RA must be returned with the RA number on the outside of the package and with pre-paid postage.

Estate Swing
13100 State Road 54
Odessa, FL 33556

Introduction and Features

Call Button for visitors: The Estate Swing GSM intercom comes with a reception box that a guest can call the resident from. The call button on the box, when pressed, directs the system to dial the phone number of first administrator. If there is no answer the system will proceed to call the second and then third administrator numbers (if second and/or third administrators exist).

Can hold 1000 authorized numbers: The Estate Swing GSM intercom can be programmed with up to 1000 phone numbers that are authorized users. These users will be able to call the gate GSM phone number and when their phone number is recognized by caller id as an authorized user the gate will open. The call is never answered by the GSM so no minutes are used in this process.

Open the gate with your phone: As an administrator you have many opening options for your gate.

- When you receive a call from a visitor you can open your gate from your phone.
- When entering the property yourself you can open the gate through a phone call to the gate or an SMS text message to the gate.
- When entering the gate, if you wish to hold the gate open longer than its normal pause time, for long trailers or trucks for example, you text a 1 time longer delay and after the one opening it will go back to normal operation automatically.
- If you want to leave the gate open, you can enter party mode and text the gate to stay open until it is texted again to close it.

Remote programming from phone: The Estate Swing GSM intercom can be programmed by an administrator from their phone through a call or text message. You can do this from any location. The system will return confirmation of successful programming through an audible confirmation by phone or a text confirmation if programmed by text message.

Visual Diagnostic Screen Plug-in: The Estate Swing GSM intercom comes with a diagnostic screen you can plug into the control board to see battery charge, signal strength and see visual confirmations of programming being performed.

Battery Backup: The Estate Swing GSM intercom comes with a built in battery backup. In the event of a loss of incoming power the system will automatically switch to battery backup. The administrators can also have an option turned on to be notified through text message of the system switching to battery back up so they can address the lack of incoming power issue. The back up battery will last approximately 8 hours.

Installation of Components

Speaker/Microphone box:

- Take the screw out of the bottom of the box.
- The face of the speaker/mic box lifts straight off, it does not slide down.
- Once the face is off you will see two screws holding the mid plate to the rear housing. Remove those screws.
- There are 4 mounting holes in the rear housing, use flat head screws (not provided) to mount the rear housing to a pillar, post or fence (not provided).
It is suggested to put a dab of silicone over and around the heads of the screws to keep insects and moisture out.
- Run the 4 colored wires through to a junction box (not provided) and splice or use wire nuts to lengthen the wire to reach your intercom control box (wire is not provided—use up to 22 gauge wire up to 200’)
Reassemble the mid plate and the face plate.

Intercom Control Box:

- Inside the box you will find a wire with a coaxial connector and a red rubber cap. Remove the rubber cap, nut and washer. [A]
Feed this through the hole on the lower right side of the box.
Put the nut and washer on the threads until it is secure against the side of the box.
Screw the antenna on the threads; there will be some visible thread on the coaxial connector even after the antenna is secured.
- You were provided two water tight wire connectors. Remove the back nut on the connectors and feed through the two large holes on the bottom of the board.
Tighten the nuts back on the threads until it is snug against the box wall.
When you run your wire, do so through these connectors and tighten the connector down on the wire to keep water and insects out.
- In the upper left hand corner, under the board, there is a backup battery. Find the red and black wires with the connector on the end. [B]
Plug the backup battery into the board when you are done with your wiring, it is easier to fish the wires out however before mounting the box.
- Mount the control box in a secure location near the gate opener control box.
- The intercom control box will have 4 wires coming into it from the speaker/mic box, 2 wires coming in for power and 2 wires going out to the gate opener. (this is for minimum installation—additional wires may be used in more advanced installations)

See the chart on the next pages for wire locations and power instructions.

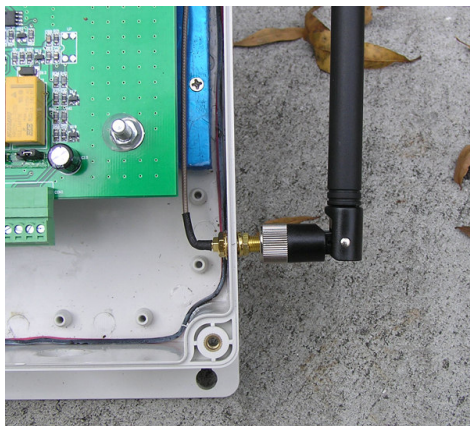

[A]



[B]

Wiring

Speaker/Microphone box to Control Box:

- **Black** wire to terminal 10
- **Red** wire to terminal 11
- **Green** wire to terminal 12
- **Yellow** wire to terminal 13
- **Run between speaker/mic box and control box should not exceed 16'**

Control Box to Gate Opener:

- **E-S 1100, E-S 1102, E-SC 1102, E-SL1200**
Terminal 4 of intercom to Terminal 13 of gate opener
Terminal 16 of intercom to Terminal 1 of gate opener
- **E-S 1600, E-S 1602, E-SC 1600, E-SC 1602, E-SU2200, E-SU2202, E-SL 1800**
Terminal 4 of intercom to Terminal COM of gate opener
Terminal 16 of intercom to Terminal OPEN A of gate opener
- **E-S 300, E-S 302, E-S 500, E-S502**
Terminal 4 of intercom to Terminal P1 of gate opener
Terminal 16 of intercom to Terminal V+ of gate opener

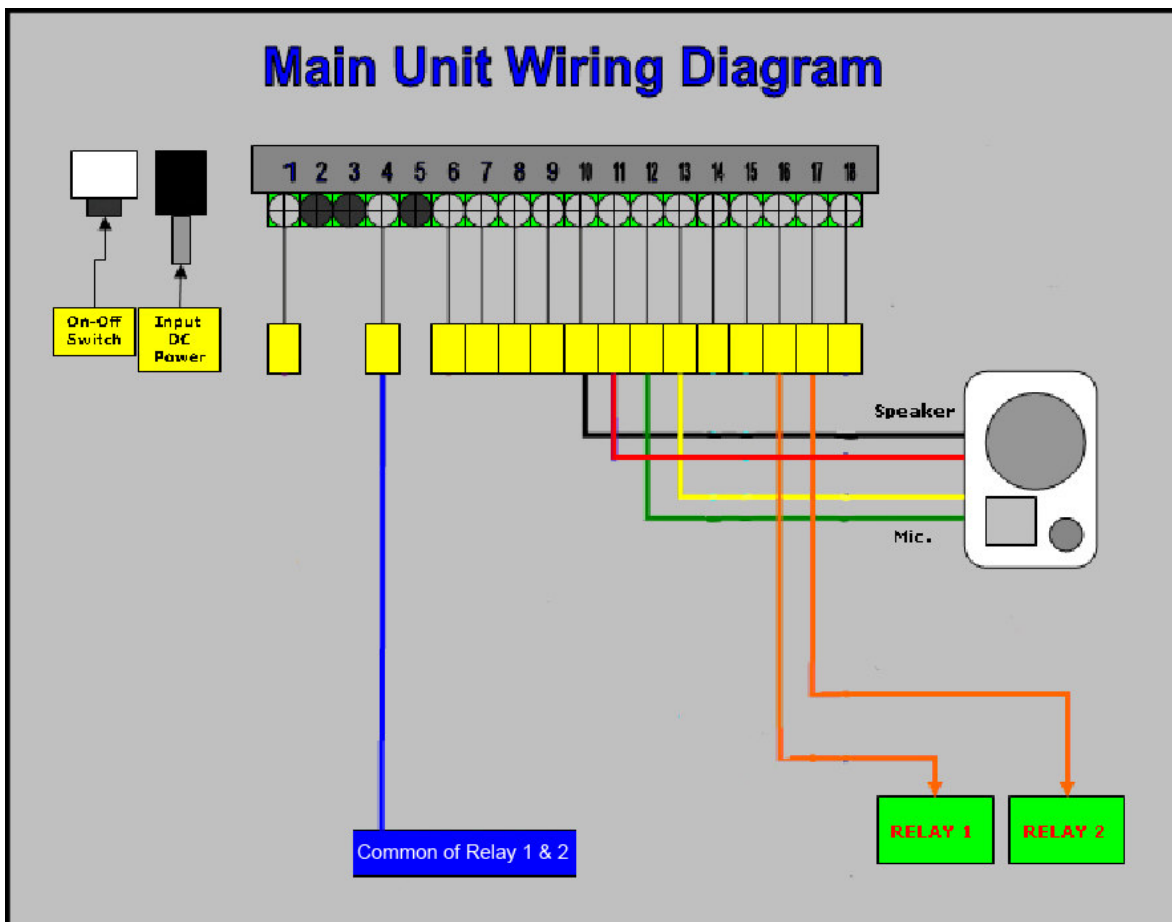

Power Connection & Sim Card:

Low voltage power connection:

- Verify the On/Off switch is in the OFF position (LEFT)
- In the bottom of the box you will see a red and black wire attached to a round connector. You will utilize this connector for your low voltage connection. Cut the red and black wire about 2 - 3 inches from the round connector.
- Using low voltage wire (16-20 gauge stranded direct burial 2 conductor) up to 500 feet connect the red wire of the connector to the positive and the black to a negative of a 12 - 24V DC transformer. The wire connections can be made using wire nuts inside the control box.
- Plug in the back up battery (upper right side of board, white connector) and plug in the round low voltage connector.
- Do not turn the On/Off switch to On until specified by the directions.



SIM Card:

- Slide back the SIM door and lift it up
- Slide the SIM card into the SIM door making sure that the clipped corner of the SIM card lines up with the clipped corner of the SIM holder



Powering up/Verification of system ready:

Digital Diagnostics Board:

The plug in LED board that comes with the unit is for diagnostic purposes. It is recommended that you have the installed when you first turn on the system so you can check your system statuses. **After you feel confident with programming or when you close the control box; take the diagnostic display off the board and store it in a safe dry location.**

Turn System on:

- Flip the On/Off switch to the right.
- **ATTN: When you first turn the system on the system will actuate the gate. Stand clear of the gate.**

Once you turn on the system you will see the following

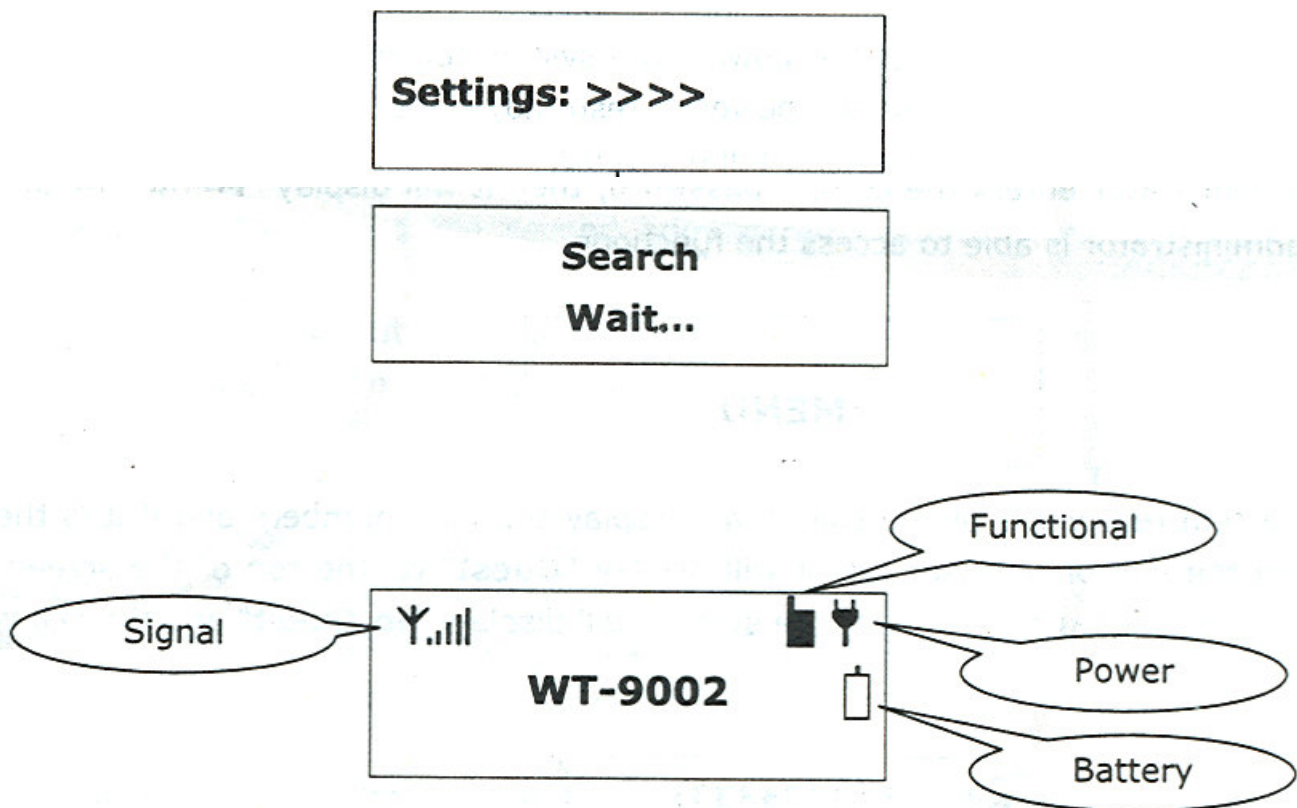

Now the system is ready for programming.

Programming Administrator Numbers:

Administrator codes:

Administrators can program the system, open the gate via cell phone and receive the phone calls from the gate call box.

Programming via phone call:

The administrator numbers can be programmed individually or all in one call

using the following [Example numbers are (1111558888), (2222669999), and (3333770000) - substitute real phone numbers in your programming]. Only one administrator needs to be established to begin using the system.

Example:

Once the call has connected... (With a short beep ~ prompt the administrator to enter password, the initial set up password is 123456 by default)

After enter password... (Another short beep ~ Password Correct)

Press *3# (you should hear a short beep ~ success)

Continue press 1# to add the first administrator number (another short beep ~ success)

Then enter the administrator number 1111558888# (you will hear a short beep ~ the administrator number is setup successfully)

Continue...

Press *3# (you should hear a short beep ~ success)

Continue press 2# to add the second administrator number (another short beep ~ success)

Then enter the administrator number 2222669999# (you will hear a short beep and the number has been changed to 2222669999)

Continue...

Press *3# (you should hear a short beep ~ success)

Continue press 3# to add the third administrator number (another short beep ~ success)

Then enter the administrator number 3333770000# (you will hear a short beep and the number has been changed to 3333770000)

If the change has not been successful you will hear 3 beeps and must re-enter again.

Programming via Text Message (SMS) on next page.

Diagnostic display read out below

TEL: 1#, 2#, 3#



TEL: 1#

TEL: 1111558888
1#



TEL: OK

Programming Administrator Numbers (cont):

Programming via Text Message (SMS)

Send the following 3 SMS Commands:

- 1) ***TEL1#1111558888**
- 2) ***TEL2#2222669999**
- 3) ***TEL3#3333770000**

As the first 2 numbers will be the customers own numbers you would program in the Installers number in
***TEL3#**

This number can be changed once the system has been installed.

When the system received the message and the number is programmed successfully, it will display “**OK**” on the screen and the administrator will receive a reply message from the unit.

Example of Return Message:

TEL1=1111558888

TEL2=2222669999

TEL3=3333770000

To change an administrator number you can simply SMS or call and write over the TEL#. You have to be an administrator to do this.

Phone Call From Gate

When a person presses the call button at the gate the #1 administrator will receive a phone call from the front gate.

If they do not answer it will roll to the #2 and then to the #3.

In order to open the gate through Relay 1 (this is the primary relay that is normally hooked to the gate opener) the administrator should press:

***0#**

In order to open a secondary device through Relay 2 (this is the relay that is normally hooked to a pedestrian gate lock or other device) the administrator should press:

***1#**

In order to disconnect the call from the gate without opening the gate (this would be if you did not want to let the person in) the administrator should press:

***4#**

This can also be used before hanging up after opening the gate to be sure that the network doesn't hold the call from the gate and waste minutes.

Changing Administrator Pass Code from Default:

Programming via phone call:

The system only allows the 3 administrator numbers as authorized user to change the 6 digits password.

To change the password from the factory default 123456 to 654321 (Example) you can just call the unit and when the unit replies, you can use the following commands using the keypad prompts on your telephone.

Once the call has connected ... (With a short beep ~ prompt the administrator to enter password, the initial set up password is 123456 by default)

After enter password... (Another short beep ~Password Correct)

Press ***2#** (A short beep ~ success)

Then input the current password **123456#** (you should hear a short beep ~success)

Continue to enter new password **654321#** for 2 times (another short beep if password entered correctly)

If the change has not been successful you will hear 3 beeps and must re-enter again.

Programming via Text Message (SMS)

Example:

Sends a SMS Command: ***PAWO#654321**

If the change is successfully, the system will display “**OK**” on the screen and the administrator will receive a reply message from the unit.

Returned Message:

PAWO-OK

Resetting forgotten password

In the event the password is forgotten or cannot be accessed, you can send the following SMS to the unit and the system will be reset to factory default as ***123456#**

Sends the SMS Command ***REST#615858** and the unit will reply **REST-OK** and the password is now back at factory default as ***123456#**

To manually reset the unit, you can press and hold on the “Call” button and turn on the unit for 10 seconds. The unit will displays **Wait...** and then **OK**, the unit is reset.

Programming User Access Phone Numbers:

IMPORTANT—PLEASE READ FIRST

User access numbers can open the gate by calling the gates phone number and the call id of the unit will recognize their number and open the gate for them. In order for the system to rapidly sort recognized numbers it stores them in lists 0 through 9. There is the ability to keep up to 99 numbers in each list. It will be much easier if you organize your phone numbers by list and slot number before programming. The last digit of the phone number determines its list. Example: if the number ends in 2 then the number has to be in list 2. The slot number (01-99) in list 2 is up to you.

Example of a user list

| | | |
|--------|--------------|-------|
| List 0 | | |
| | none | |
| | | |
| List 1 | | |
| Slot 1 | 684-727-1991 | jack |
| Slot 2 | 305-700-2261 | larry |
| | | |
| List 2 | | |
| Slot 1 | 734-253-5832 | mel |
| | | |
| List 3 | | |
| Slot 1 | 813-343-0913 | karen |
| | | |
| List 4 | | |
| | none | |
| | | |
| List 5 | | |
| | none | |
| | | |
| List 6 | | |
| Slot 1 | 312-348-6546 | helen |
| Slot 2 | 422-311-9846 | troy |
| Slot 3 | 422-875-2116 | steve |
| | | |
| list 7 | | |
| Slot 1 | 813-945-8537 | tom |
| | | |
| List 8 | | |
| Slot 1 | 213-253-9748 | sue |
| | | |
| List 9 | | |
| | none | |

Programming User Access Phone Numbers (cont):

Programming via phone call:

To program [Example number **222222226** into position 03] in the list:

Press ***5#** (A short beep ~ success)

Continue press **603** (you should hear a short beep ~success)

Then you can input the phone number **222222226#** (A short beep ~ success)

And **222222226** is programmed into position 03 in list 6

Note: If the last digit guest number entered was not match with the list number, the number will not program successfully.

Diagnostic display read out below

Guest:6>03;

Guest:6>03;
222222226

If the change has not been successful you will hear 3 beeps and must re-enter again.

Programming via Text Message (SMS)

Example:

To program phone number: 333333331

Sends SMS command ***BOOK#01#333333331**

Hence 333333331 is listed in position 01 in List 1

Returned Message: **BOOK(1>01;)= 333333331**

For phone number: 444444441

Sends SMS command ***BOOK#02#444444441**

Hence 444444441 is listed in position 02 in List 1

Returned Message: **BOOK(1>02;)= 444444441**

Deleting a number via Text Message (SMS) [can only be done through text]

Example:

To remove phone number: **666666667**

Simply sends a SMS Command ***DEL>#666666667** to the unit and it will search for number (666666667) in the list and delete it.

Returned Message:

Delete-OK

Alternate Relay Activation:

Activating relay 2:

There is a second relay which can control another device like a pedestrian gate. You can activate it using text messaging from an administrator phone. (as well as relay 1)

Send either of the the following 2 SMS Command:

- 1) *ECL1#
- 2) *ECL2#

Returned Message:

ECLK1<OK>
ECLK2<OK>

Party Mode:

You can latch relay 1 or 2 to stay on until commanded to turn off, which can be used to open the gate and hold it open.

Send either of the following 2 SMS Command:

- 1) *FRL1#1 – Latch Relay1 to stay ON
- 2) *FRL2#1 – Latch Relay2 to stay ON

Returned Message:

FRL1<ON>
FRL2<ON>

Send either of the following 2 SMS Command to turn OFF:

- 1) *FRL1#0 – Switch OFF Relay1
- 2) *FRL2#0 – Switch OFF Relay2

Returned Message:

FRL1<OFF>
FRL2<OFF>

Alternate Relay Activation (cont):

Temporary longer latch:

You can extend the time the gate pauses in the open position by extending the relay latch time for a single use. This is helpful if you are driving a slow moving or long vehicle. It can be held for up to 65000 seconds.

Via phone call:

Once the call has connected... (With a short beep ~ prompt the administrator to enter password, the initial set up password is 123456 by default)

After enter password... (Another short beep ~ Password Correct)

Press *6# (A short beep ~ success)

Continue press 1# for relay 1 (A short beep ~ success)

Then input value 00030# (A short beep ~ success)

Relay 1 will now latch for 30 seconds and after 30 seconds it will switch off and sends a message back to the administrator informed that Relay 1 has closed.

Via text message (SMS):

Example:

Temporary latch Relay 1 for 60 seconds or

Temporary latch Relay 2 for 180 seconds

Simply send either of the 2 SMS command as below:

***RLY1#00060**

***RLY2#00180**

Example of Returned Message:

RELAY1=00060

RELAY2=00180

Special Functions:

Admin and user access:

It is possible to control the access of administrator or user to the system by sending the following SMS command to the unit.

Sending SMS Command ***ANY?#1**, the system will allow only the administrators to gain access to the system and the authorized users in this case will not allow to access the system. (**Factory Default: *ANY?#0** ~ Any person can gain access to the system)

Note: It is advised that the owner should set the system to allow access only for administrators after programmed the Administrator numbers.

Sending SMS Command ***TEL?#1**, the system will **Not** receive phone call from both administrators and users but will activate relay 1 immediately. (**Factory Default: *TEL?#0** ~ able to receive phone call only from administrator but will not activate relay 1 immediately)

Text Reporting to Admins:

It is possible to turn ON/OFF the request of report message when inputs triggered from the unit by sending the following SMS command to the unit.

Example of sending the below command:

***RERN#100** (Factory Default)

Only Administrator number **1#** will receive a report message after setup

Returned Message:

RERN:<100>

***RERN#110**

Administrator number **1#** and **2#** will receive a report message after setup

Returned Message:

RERN:<110>

***RERN#111**

All the Administrators will receive a report message after setup

Returned Message:

RERN:<111>

Sending the below command will turn Off this feature:

***RERN#000**

Special Functions (cont):

Check signal strength:

To check the signal strength (0-31), you would send the following SMS command to the unit.

*CSQ?#

Example of Returned Message:

CSQ=<27>

Power Loss Report:

The unit is able to send alert message to the administrator in the event the main power is out / turned off. When the main power is restored it can notify the administrator again the main power is on.

When main power **OFF**

The unit will send a message: **ACP-OFF**

Note: At the same time, it will send an ALWAYS high pulse out from I/O port. Alarm will sound.

When main power restored

The unit will send a message: **ACP-ON**

Intercom Volume:

It is possible to adjust the volume (from level 1 to 6) of the intercom by sending the following SMS command. **Factory Default:**
4

Example: Sending the following SMS Command

*SOUD#5 – Adjust the volume to 5

Example of Returned Message:

SOUND:<5>

Remote System Check:

It is possible to check the system is operating correctly by sending the following SMS command to the unit.

Send the following SMS Command:

*TEST#

When the unit replies **TEST-OK** indicate the unit is operating correctly.

Note: If you receive no reply then unit is not working

Trouble Shooting:

An alarm keeps sounds repeatedly and/or power loss text keeps being sent after switching unit on:

- Check to be sure the transformer is a DC transformer. AC power will repeatedly turn the power on and off and create multiple text messages. AC power may also do irreversible damage to the control board.

Text messages are not being returned:

- Turn the power off for 5 seconds and then turn back on. This will reconnect your SIM card with the network.
- Check to see who is an administrator, if you are no longer an administrator you will not receive text notifications.
- Check to see what # administrators are programmed to receive notification; if any at all. (under special functions)

I need to reset my entire unit:

- Turn the unit off. Plug in the digital read out. Press and hold the “Call” button on the gate. Turn the unit back on and wait approximately 10 seconds while holding the call button on the unit. The unit display will read “Wait...” and when finished will read “OK”. At this point the unit is reset and your password is returned to *123456#

I cannot get my SIM card to react to programming:

- Many SIM cards have an initial 4 digit security PIN code. This must be disabled. This can be done by placing the card in an unlocked cellular phone and checking to see if the SIM requested a PIN. If there is a PIN requested, it can be disabled through the phones security settings.