



# *Quartet 2015*

**Cordless Telephone & Digital Answering Machine**



# User Guide

This equipment is not designed for making emergency telephone calls when the power fails. Alternative arrangements should be made for access to emergency services.

**Please open this page for an 'at a glance'  
guide to your Quartet 2015.**



# At a glance

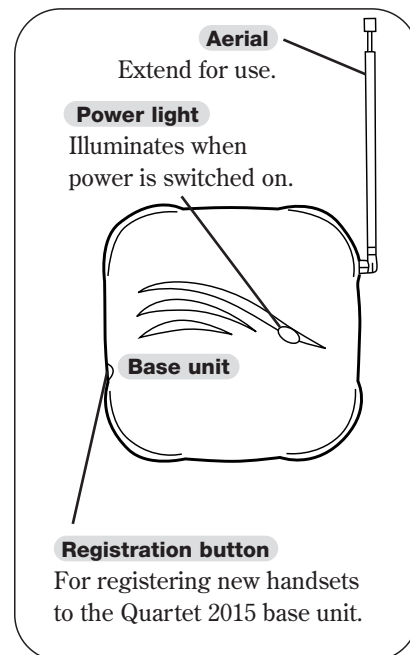
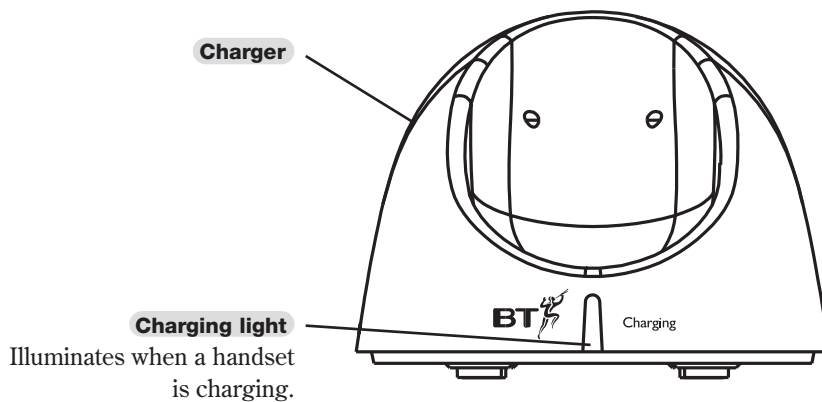
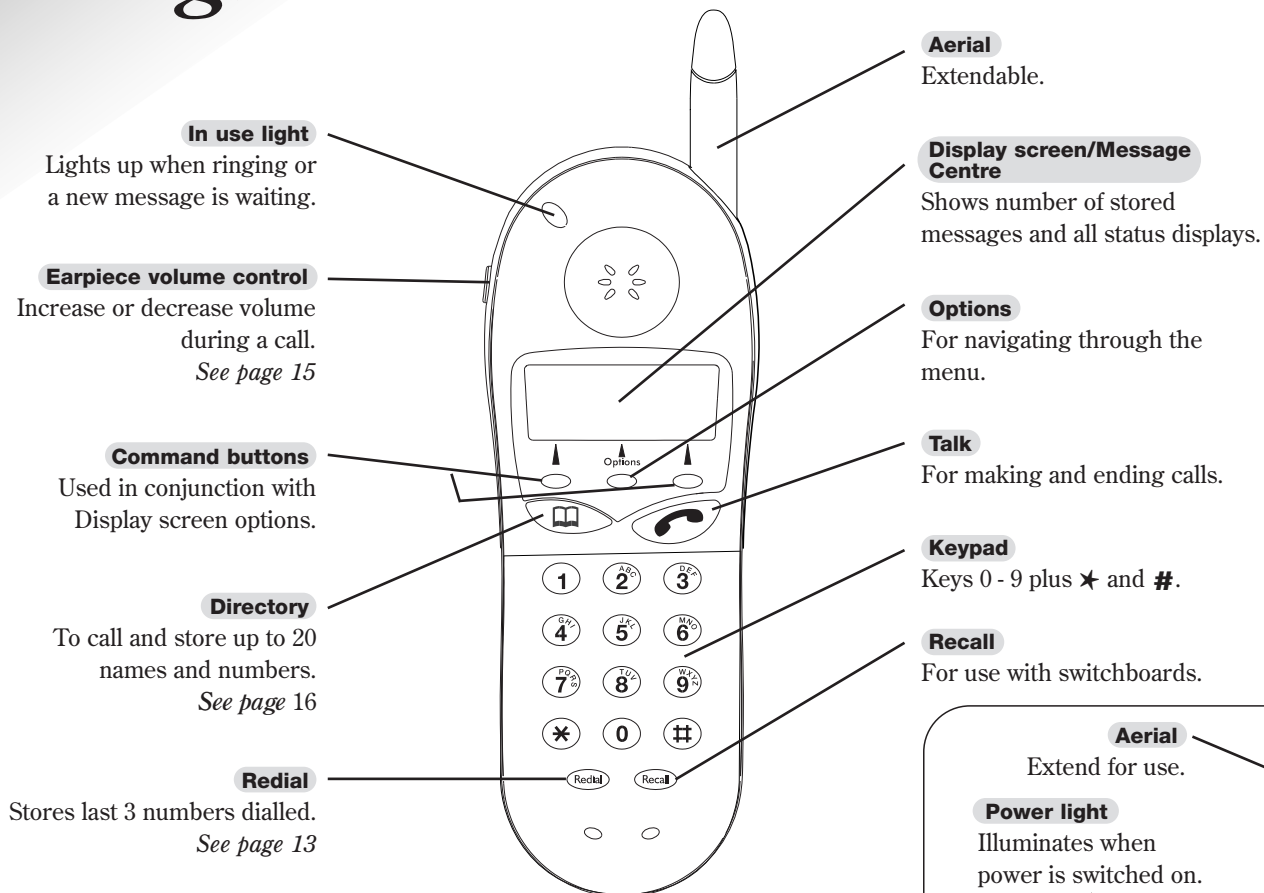



# *In this guide*

<i>At a glance</i> .....	1
<i>Introduction</i> .....	4
<i>Setting up</i> .....	6
<i>Using your Quartet 2015</i> .....	8
<i>Making and receiving calls</i> .....	12
<i>Using the directory</i> .....	16
<i>Using the answering machine</i> .....	19
<i>Optional settings</i> .....	32
<i>Using Select Services</i> .....	35
<i>Using additional handsets</i> .....	44
<i>Wall mounting</i> .....	46
<i>Help and advice</i> .....	48
<i>Technical advice</i> .....	50
<i>Index</i> .....	52
<i>Wall mounting template</i> .....	53

# Introduction

*Your BT Quartet 2015 combined cordless telephone and digital answering system is designed for ease of use and is made to BT's high standards.*

The BT Quartet 2015 combines the advantages of cordless operation with the performance of a high quality telephone and digital answering system. It offers unparalleled quality and features.

## Cordless telephone functions

Your Quartet 2015 offers you the convenience and flexibility of a cordless telephone system and has been specifically designed to be easy to use. You can use up to 4 handsets with the base unit and transfer calls between them. The handset is highly functional and has a clear and simple display to assist you to use the many helpful features of your telephone, answering machine and BT Select Services.

## Directory

The Directory, which you access via the directory button, allows you to store up to 20 names and numbers in alphabetical order. You can scroll through and edit or delete them. You can also preview entries and set up calls directly from them.

## Answering machine

The answering machine allows callers to leave a 3-minute message tagged with the day and time. You can also record memos for family or colleagues. Different outgoing messages can be recorded and used on demand.

If you want your caller to leave a message, set to 'Answer and Record' if not, set to 'Answer Only'. The Quartet 2015 has pre-recorded greetings and voice prompts and has visual and audible signals to alert you when new messages have been left.

## Select Services

Your Quartet 2015 is designed to make it easy for you to access and manage BT's Friends & Family and certain BT Select Services. For instance, you may also want to change the time for your Reminder Call or switch Call Waiting on or off. These can all be edited, enabled or cancelled via the handset display.

## Handset functions

Apart from some very basic functions on the base unit and charger, your Quartet 2015 is managed almost entirely from the handset. Using the handset's display screen and buttons, you can edit and activate the functions of your Quartet 2015, both on and off-line. The main method of control, is via a tree of *menus*, which you can access and navigate through by using buttons beneath the Display. Please see *'Menu options'*, page 8.

## Unpacking your Quartet 2015

Check that your BT Quartet 2015 is complete.  
When you unpack it, you should have:

- BT Quartet 2015 base unit with telephone line cable attached.

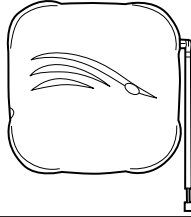

- Cordless handset

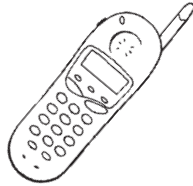

- Charger

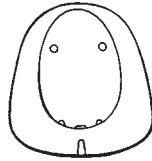

- 2 x 13 amp mains power adaptor plugs

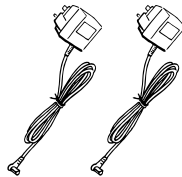

- Wall plugs and screws



## For your records

Date of purchase:

Place of purchase:

Serial number (on the underside of the telephone base unit):

Purchase price:

For warranty purposes, proof of purchase is required, so please keep your receipt.

# Setting up

Follow these steps to get your Quartet 2015 ready for use.

## Situating your Quartet 2015

Position your Quartet 2015 within 2 metres of a phone socket and 3 metres of a mains power socket.

Do not stand it on carpets or other similar surfaces which might generate fibres.

Do not cover or enclose the machine. Allow a free flow of air to its surfaces.

For the best performance do not position your Quartet 2015 close to other electrical equipment, eg. TV's or large metal objects, metal cabinets etc.

Your Quartet 2015 can be wall-mounted. For instructions on how to do this, see 'Wall-mounting' on page 46.

If you have any problems setting up or using your Quartet 2015, please call Helpline on **08457 697330**.

## 1 Plug your Quartet 2015 base unit into the telephone wall socket

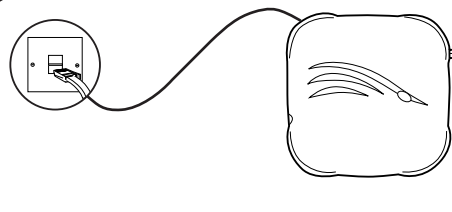

If you do not have a modern-style socket, call **Freefone 0800 800 150** and ask for a BT engineer to come and fit the correct type. This is a chargeable service.

## 2 Plug your Quartet 2015 base unit and charger into the mains power socket

There is one mains power adaptor for the charger and one for the base unit. Simply plug one end in the socket provided on the underside of each box, plug the other end into a mains power supply socket, and switch on.

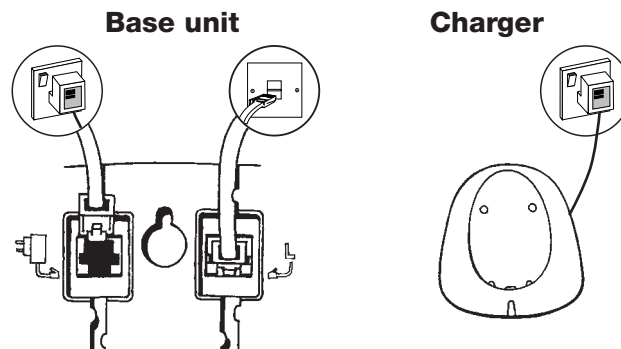



### 3 Charge the handset batteries for at least 24 hours

Before you use your Quartet 2015 for the first time, it is important to have the handset batteries fully charged. We recommend that you leave the Quartet 2015 handset on the cradle charger for at least 24 hours.

#### Battery Low Indication

*When the batteries need re-charging, the display will show a 'battery low' symbol. Replace the handset on the charger to re-charge.*

### 4 Aerial

It is advisable to extend the aerials on both the handset and base unit for optimum performance.

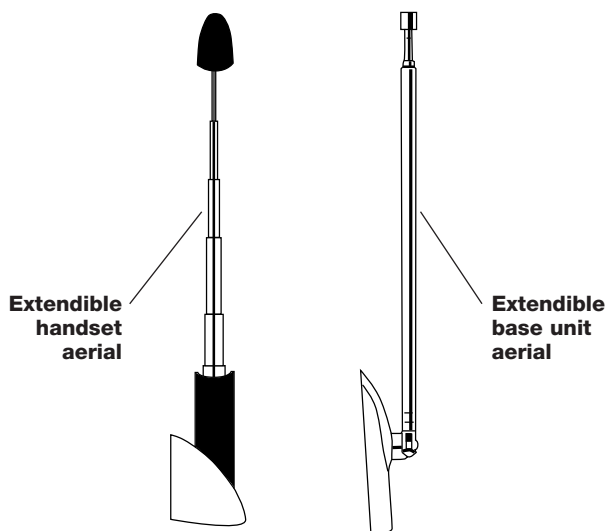

---

Your Quartet 2015 is now ready for use.

---

# Using your Quartet 2015

## Menu options

Your Quartet 2015 uses a display on the handset which allows you to select from the various product features detailed throughout this guide. Using the keypad, you are guided through the menu options by the prompts on the display.

At standby (that is the basic screen when not in use) the handset display shows:



Press the **Options** button. This opens the top level menu, showing the first of 3 main options. The first is:



Press **Options** again. Display shows:

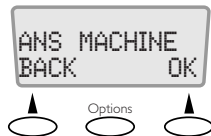

Press **Options** again. Display shows:



Each menu option offers you with a choice of prompts that appear on screen (ie. **BACK**, **OK**) which are selected using the 2 buttons located just below the display.

The **Options** button is in the middle of these.

For example, if you press **OK** when in **ANS MACHINE**, you will be presented with a further menu of 3 screens, which you move between by pressing the **OPTIONS** button again.

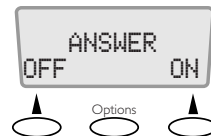

Press **Options** button. Display shows:

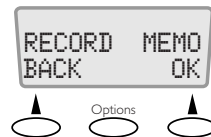

Press **Options** button again. Display shows:



If you wish to select an option, press **OK**, or **BACK** to move back to the previous menu.

When you wish to exit the menus completely, press and hold **BACK**.

Replacing the handset in the charger at any time will return the system to standby.

When you have reached the feature you wish to select or change, just follow the on-screen or voice prompts to complete.







Using the menus you can edit and set up the Select Services you subscribe to, switch the answering machine on and off, record outgoing messages, set answer modes or change the number of rings before your outgoing messages cut in.

#### PLEASE NOTE

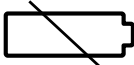
*For more details of the menus and how they work, please refer to the relevant sections in the guide itself.*

## Display symbols

The following symbols may appear on your handset display.

Symbol	Meaning
	Battery Low
	Call Transfer
	In Use
	Answering machine ON
	You have messages stored on your answering machine
	Flashing indicates you have new messages stored

## MENU STRUCTURE (WHEN IN STANDBY)

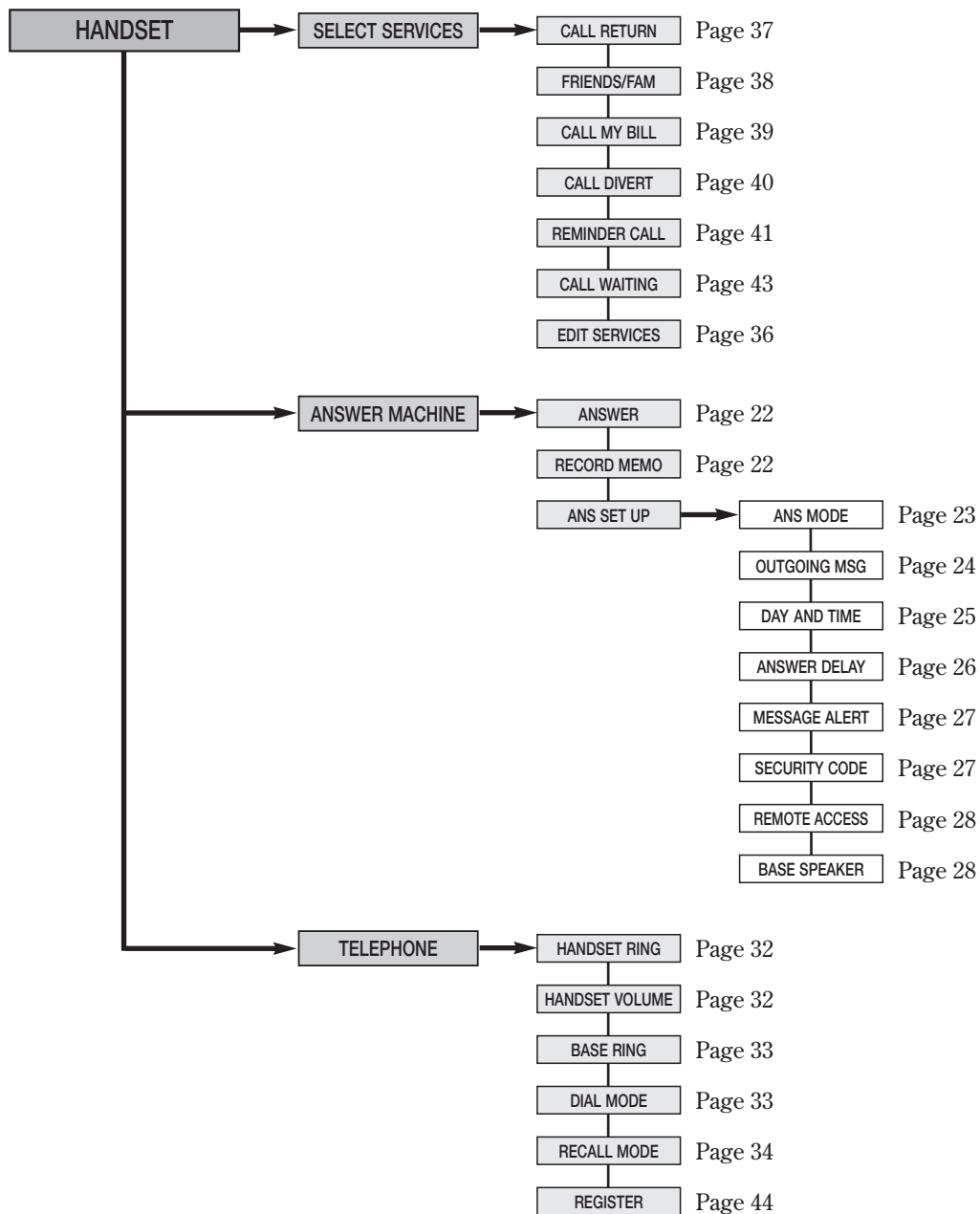

## MENU STRUCTURE (DURING A CALL)

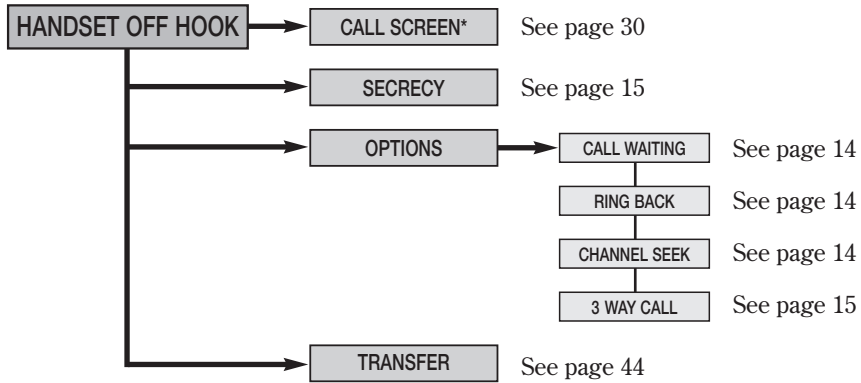

\*This menu is only available when the answering machine has answered an incoming call.

# Making and receiving calls

## To make a call

*Press buttons in order shown*



Press the **TALK** button to obtain dial tone.

The handset display shows **MAKING LINK** then , to indicate you are now connected to a line.

### DIAL

Key in the phone number. The number is displayed and dialled.

If the number keyed in has more than 12 digits, the number scrolls along to the left so that the last 12 digits are always displayed.

Within 10 seconds of the number being entered the call timer starts from zero, 00:00:00.

## PLEASE NOTE



*After using one of the 3 option buttons or the **TALK** button, the words **MAKING LINK** may momentarily appear in the display. This confirms that a command has been accepted and is being acted upon.*



## To view the number before dialling

To make a call, you can choose to enter the number first, before you dial it.

Enter the number you wish to dial.

### DIAL

The number will appear in the handset display together with  for back and  for forward. The black cursor will flash.

To delete a digit press and release the button under the  symbol. Press the button under the  symbol to insert a space.



When you have entered the full number, press the **TALK** button. Your number will be dialled. (If you do not press the **TALK** button, you will be returned to standby after 20 seconds.)

The display shows the number of the person being called. Within 10 seconds of the number being dialled the call timer starts from zero, 00:00:00.

## To end a call



Press the **TALK** button or replace the handset in its charger.

## To redial the last number

Using the redial button that is located on the bottom left side of your handset:

 Redial

Press the **REDIAL** button. The last number called appears in the display. This allows you to check it before dialling.



Press **TALK** to dial the call.

An alternative way of doing this is:



 Redial

Press **TALK**, then the **REDIAL** button. The number is immediately dialled.

**REDIAL** will store the last 3 numbers called.

 Redial

Press the **REDIAL** button until the number you wish to redial is displayed.



Press **TALK** to dial.

## To receive a call

When the phone rings:

The light on the handset flashes.

Display shows **CALL**. This occurs both on and off the charger.

*If the handset is in its charger:*

Lift the handset and you are immediately in contact with the caller.



To end the call, press the **TALK** button or replace the handset in its charger.

*If the handset is not in its charger:*



Press the **TALK** button.

If another registered user picks up the call, an error tone sounds.



To end the call, press the **TALK** button or replace the handset in its charger.

## To switch on the keyguard

You may like to lock your keypad when you are carrying it around. This stops you from accidentally dialling any numbers.



Press the left button (under the display) followed by the ★ button. Display shows **KEYGUARD ON**.



If you now try to dial, display will show **KEYGUARD CANCEL**. When you wish to cancel the keyguard, press the left button (under the display) followed by the ★ button.

## Options during a call

You can use a number of additional functions during a call.

### To seek a stronger channel

*Press buttons in order shown*

Options



Press the **OPTIONS** button until the display shows CHANNEL SEEK.

OK

Press **OK**.

The handset automatically finds the best channel. CHANNEL SEEK will disappear from the display.

Your call will continue during Channel Seek.

### To answer a Call Waiting call

For an explanation of Call Waiting service, please see page 36.

When you hear the Call Waiting beeps during a call:

Options



Press the **OPTIONS** button until the display shows CALL WAITING.

SWITCH

Press **SWITCH** to speak to the other caller. Your first call will be put 'on hold'.

SWITCH

Press **SWITCH** to toggle between the 2 callers.



When you wish to end one of the calls, press the **TALK** button. Your current call will end.



Your handset will ring, display showing CALL. Press the **TALK** button and you will be re-connected to the remaining caller. Press the **TALK** button again when you wish to end the call.

### To use Ring Back for an engaged number

**NOTE:** Ring back service must be available – check with network provider.

Options



If the number you are calling is engaged, press the **OPTIONS** button until the display shows RING BACK.

OK

Press **OK**. Voice says 'Your Ring Back request has been accepted'.



To end the call, press the **TALK** button or replace the handset in its charger.

When the engaged number becomes free, your phone will ring and you will be connected to the person you were trying to contact. (They will answer the call as if you had just called them.)



## To use the secrecy function

While on a call, if you wish to talk to someone close by without the person at the other end hearing the conversation, you can use the secrecy function.

During a call:

**SEC** Select the **SEC** option.  
The display shows **SECURITY ON**.

This confirms that you have activated the secrecy function and you can now talk without the other person at the end of the line hearing you. You will also hear a beep every 5 seconds or so.

**SEC** To allow the caller to hear you again, select **SEC**. You can now resume your conversation.

To end the call and return to standby, press **TALK**.



## To adjust the handset earpiece volume (speech)

While on a call or listening to messages:

**VOL** To adjust the volume of speech of the person you are talking to, press the **VOLUME** button situated at the top left-hand corner of the handset.

The volume will get louder or softer, depending on the start point, and will beep twice when it has reached either the highest or lowest volume setting. It will then go back the other way.

**VOL** Press and release the volume button to increase/decrease for the required level.

## To use 3 Way Calling

During a call.

**Options** Press the **OPTION** button until display shows **3 WAY CALLING**

**OK** Press **OK**.

Key in the phone number you require.

**JOIN** Press **JOIN**.

You can now speak to both parties.

To end the call, press the **TALK** button or replace the handset on the charger.



# Using the Directory

Your Quartet 2015 can hold up to 20 names and numbers in its directory which will be stored in alphabetical order.

You can add names to the directory and edit or delete them as required.

You can also set up calls from entries in the directory.

## To store an entry in the Directory

*Press buttons in order shown*



Press the **DIRECTORY** button. The display shows **EMPTY** or your first directory name.

**NEW**

Select **NEW**. Display shows **ENTER NAME**.

**KEYPAD**

Key the first letter of the name you wish to enter. (For instance, to display the letter **C**, press the **2** button until **C** appears on the display.)

You will now see the letter just entered, and the cursor will start flashing under the next letter space after a few seconds.

### NOTE

*If you want to enter 'C' followed by another 'C' wait for a few seconds for the cursor to automatically move onto the next space before entering the second 'C'.*



Finish entering the letters of the name, using the **>** symbol to insert a space between the first and last name.



To delete a letter, use the **<** symbol.

**SAVE**

Press **SAVE**. The display shows **ENTER NUMBER**.

Enter the number in the same way as you entered the letters. If there are more than 12, they will be scrolled along, allowing the last 12 digits to be shown.

Insert a space if you wish (this is ignored during dialling).

To insert a pause in the string of digits (for instance for switchboard access), press the **REDIAL** button. The pause is shown as **P**.

**Redial**

**SAVE**

Press **SAVE**. Display shows **UPDATING DIRECTORY** followed by **SAVED**.

Display confirms name and number together for up to 15 seconds, then returns to standby.

**BACK**

Press and hold **BACK** to return to standby.

### DIRECTORY FULL

*If you try to store a new entry and you see the message **DIRECTORY FULL**, you will need to delete an entry before you can store any others. See 'to delete an entry in the directory' page 18.*

## AVAILABLE CHARACTERS

1 = & ' ( ) 1

2 = A B C 2

3 = D E F 3

4 = G H I 4

5 = J K L 5

6 = M N O 6

7 = P Q R S 7

8 = T U V 8

9 = W X Y Z 9

## To add extra entries to the directory



Press the **DIRECTORY** button.

Options



Press the **OPTIONS** button.

NEW

Select **NEW**.

Follow the process on the previous page.

## To edit an entry in the directory



Press the **DIRECTORY** button.



Use the **DIRECTORY** button to scroll through the names until the name you wish to edit appears.

Options



Press the **OPTIONS** button. The display shows the name.

EDIT

Press **EDIT**. You will now see the name, such as LOUISE DAVIES. Use the backspace, the forward space and the keypad to edit the name. Then press

SAVE

**SAVE** until a beep sounds.

SAVE

If it is only the number you wish to edit, press **SAVE** to confirm the name.

SAVE

Edit the number as before. Press **SAVE**. The revised name and number are displayed.

BACK

Press **BACK** to return to standby.

## To view and then dial a call from the directory

*Press buttons in order shown*



Press the **DIRECTORY** button. The first stored name is displayed with the telephone number.



Press and release the **DIRECTORY** button to move to the next entry.

*Or*



Press and hold the **DIRECTORY** button to scroll through all entries. These are in alphabetical order. After reaching Z the scrolling takes you back to letter A.

If the number has more than 12 digits the display scrolls to the left.

*Or*



To go to a specific entry, use the **DIRECTORY** button then the handset keypad to enter the first letter of the name. For example, for “C Davis” press button **2** three times, for C, wait for the display to show the first directory entry under ‘C’, then press the directory button to access any further names under ‘C’.



If there are no entries under a section beginning with the chosen letter, the display will move to the next section and letter.

*To dial the number on the screen:*



Press the **TALK** button. The name of the person will appear on the display for a few seconds before the call timing begins.

## To delete an entry in the directory



Press the **DIRECTORY** button. The first entry appears on the display.



Use the **DIRECTORY** button to scroll through the names until the name you wish to delete appears.

Options



Press the **OPTIONS** button. The display shows the name.

DEL

Press **DEL**. The display shows DELETE?

YES

Press **YES**. After a few seconds you will hear a double beep and the display then shows UPDATING DIRECTORY then ENTRY DELETED.



After confirmation of the deletion has been displayed for one second, the next entry in the directory is displayed.

# Using the answering machine

When you are unable to answer the phone, your Quartet 2015's digital answering machine will take messages. You can also leave your own recorded messages (see Memos, page 22). Your Quartet 2015 can record up to 15 minutes of messages in total, including the outgoing messages.

You can skip backwards and forwards through your messages and memos and delete or save any or all of them.

Your Quartet 2015 handset display shows the following symbols relating to the answering machine functions.

Symbol	Meaning
	Answering machine ON
	You have messages stored on your answering machine
	Flashing indicates you have new messages stored

The answering machine can be operated from your Quartet 2015 cordless phone or any external phone provided it is a *Touchtone*™.

## Voice prompts

The Quartet 2015 makes using your answering machine easy by using voice prompts as well as the instructions on the handset display.

These announcements can be heard at the base unit, or through your Quartet 2015 handset.

We recommend that initially, when setting up your answering machine, you also listen to the announcements from the base unit.

Messages are tagged with the day and time which is announced to you at the end of each individual message during playback. To ensure that this information is accurate you must set the date and time. See page 25.

You can adjust the base speaker volume or switch it off (see page 28). The base speaker enables you to clearly hear when messages and voice announcements are being played.

## Recording time limit

The system also has its own pre-recorded concluding announcement.

This cuts in automatically to warn callers that they are about to, or have, run out of time for recording their message.

Incoming messages are restricted to a maximum of 3 minutes, with 15 minutes of recording time in total.

### PLEASE NOTE

*If a period of silence in excess of 8 seconds occurs during the recording of the outgoing messages, memos or incoming messages the answering machine will stop the recording and return to standby.*

## Memos

You can leave messages for members of your household or office colleagues. Memos can be recorded and saved as if they were normal answering machine messages. There is no time limit on the length of a memo.

## Outgoing messages

The Quartet 2015 contains two different outgoing messages which you can replace with a recording in your own style and voice.

Of these 2, one announcement invites callers to leave a message. This is *Answer and Record* mode. The second enables you to leave an announcement, but does not allow callers to leave a message. This is *Answer Only* mode.

Your Quartet 2015 will automatically switch to *Answer Only* mode when your message memory is full.

## Answer Delay

It is possible to change how many times your phone will ring before the answering machine takes a call. The length of the delay is set using ANSWER DELAY in the ANSWER SET UP menu options.

Your Quartet 2015 has the following settings: 2, 3, 4, 5, 6, 7, 8, 9 and TIMESAVER (Time Saver).

### PLEASE NOTE

*If the answering machine is set to TIMESAVER it will automatically answer after 2 rings if you have any new messages, or after 6 rings if you have no new messages.*

*This facility is useful if you wish to interrogate your system remotely, since if your answering machine does not answer after 2 rings, you will know that there are no new messages and you can choose to hang up.*

## Message alerts

Your Quartet 2015 features an audible Message Alert function for new incoming messages. When the message alert function is switched on, the handset will beep every 10 seconds to let you know you have new messages.

Even if the message alert function is switched off, you can still see if you have new messages as a visual alert symbol  will flash in the display. If this symbol does not flash you have messages stored, but no new messages.

A red light on the top left side of the handset will also flash if new messages have been received.

The display shows the total number of messages stored, under the  symbol.

## Remote access

You can operate your answering machine from any other external phone, providing it is a *Touchtone*<sup>™</sup> phone. To do this you need a security code to prevent unauthorised access. The default setting is 0000.

Your code authorises you to access your messages from any *Touchtone*<sup>™</sup> phone.

This feature can be turned on or off.

## Call screening

Call Screening enables you to listen to incoming calls while they are being recorded, without the caller knowing. You can then choose to take the call or allow the caller to finish the message.

## To switch the answering machine on and off

*Press buttons in order shown*

Options



Press the **OPTIONS** button until the display shows **ANS MACHINE**.

OK

Select **OK**. The display reads **MAKING LINK** then shows **ANSWER**.

ON

Select **ON**. Voice says 'Answer on' and the  symbol will appear on your handset's display.

OFF

Select **OFF**. Voice says 'Answer off', and the  symbol will disappear from the display.

## To record a memo

Options



Press the **OPTIONS** button until the display shows **ANS MACHINE**.

OK

Select **OK**. The display briefly reads **MAKING LINK** then shows **ANSWER**.

Options



Press **OPTIONS** until the display shows **RECORD MEMO**.

OK

Press **OK**. The display shows **SPEAK AFTER TONE**. Voice says: 'Please speak after the tone, then press **SAVE** to confirm.'

SAVE

SAVE

Speak your memo. The display shows **RECORDING SAVE**. When finished, press **SAVE**. Voice says 'Your memo is ...' Your memo is played and then the day and time is announced.

Display reads **MEMO PLAY**.

DEL

If, during memo playback, you press **DEL**, then your memo will not be recorded, the display will show **DELETED** and voice will announce 'Message deleted'.

BACK

Press **BACK** to return to standby.

STOP

If, during memo recording you press, **STOP** or replace the handset in the charger, then you will be returned to standby immediately. In this case the portion of the message left before you stopped recording is recorded.

STOP

If you press **STOP** or replace the handset in the charger during playback the whole memo is retained and tagged with day and time.

The message symbol appears once all or part of your memo has been recorded. The red light on the handset will flash to indicate a new message has been received.



## To play back a memo

Memos are stored as normal answering machine messages. They are not then identified separately as memos. See page 29 for instructions on how to play back messages.

## To select Answer Mode (answer and record or answer only)

The Quartet 2015 contains 2 different outgoing messages which you can substitute with a recording in your own style and voice.

One announcement invites callers to leave a message. This is *Answer and Record*. The other enables you to leave a greeting, but does not allow callers to leave a message. This is *Answer Only*. When the message memory is full your Quartet 2015 answering machine will automatically switch to *Answer Only* mode.

If you choose not to record your own outgoing message, the pre-recorded ones will automatically be selected.

To choose the type of outgoing message you wish to use:

Options  

Press the **OPTIONS** until the display shows **ANS MACHINE**.

OK

Select **OK**. The display briefly shows **MAKING LINK** then shows **ANSWER**.

Options  

Press **OPTIONS** again until the display shows **ANS SET UP**.

OK

Press **OK**. The display shows **ANSWER MODE** and either **ANS AND REC** or **ANS ONLY**.

CHANGE

Press **CHANGE**. The display shows either **ANS AND REC** or **ANS ONLY**. If the option you want is displayed press **SAVE**. The display returns to **ANSWER MODE**.

SAVE

Options  

If not, press **OPTIONS** to switch to the other.

As each option appears the voice confirms either '*Answer only*' or '*Answer and Record*'.

SAVE

Press **SAVE** to make your choice.

The display returns to **ANSWER MODE**. Without leaving **ANSWER MODE** you may now record your own outgoing message.

BACK

Press and hold **BACK** to return to standby.

## To record a new outgoing message

*Press buttons in order shown*

Options



Press the **OPTIONS** button until the display shows **ANS MACHINE**.

*Then*

OK

Press **OK**. The display briefly shows **MAKING LINK**.

Options



Press **OPTIONS** until the display shows **ANS SET UP**.

OK

Press **OK**. The display shows **ANSWER MODE**.

Options



Press the **OPTIONS** button again, until display shows **OUTGOING MSG**.

OK

Select **OK**. Display shows **OUTGOING MSG**.

REC

Select **REC**. The display shows **SPEAK AFTER TONE**. Voice says *'Please speak after the tone then press save to confirm'*.

BACK

Record your message. The display shows **RECORDING**. Press **BACK** during the recording to delete what you have recorded so far. Voice says *'Message deleted'* and the display reverts to standby.

SAVE

If you complete the recording and are happy with it, press **SAVE**.

Voice says *'Your outgoing message is...'*  
Your message is played through.  
The display shows **OGM PLAY**.

DEL

To delete during playback, press **DEL**. Voice says *'Message deleted. Your outgoing message is ...'* and the system's pre-recorded message is played instead.

At the end the display returns to standby.

STOP

To stop playback (ie you are happy with it so far), press **STOP**. Your new message is retained. The display returns to standby.

### PLEASE NOTE

*Deleting your recorded outgoing messages will automatically reinstate the original pre-recorded message.*

*It is not possible to delete any of the pre-recorded messages.*

## To listen to or check your outgoing messages

Options



Press the **OPTIONS** button until the display shows **ANS MACHINE**.

OK

Select **OK**. The display briefly shows **MAKING LINK**.

Options



Press **OPTIONS** until the display shows **ANS SET UP**.

OK

Press **OK**. The display shows **ANSWER MODE**.

Options



Press the **OPTIONS** button again. The display reads **OUTGOING MSG**.

OK

Select **OK**. The display reads **OUTGOING MSG**.

PLAY

Press **PLAY**. Voice says *'Your outgoing message is ...'* and the current message (ie *Answer only* or *Answer and Record*) is played. The display shows **OGM PLAY**.

STOP

If you are happy with the message while it is still playing, press **STOP**. Alternatively, wait until the end. In both instances the display returns to standby.

DEL

However, if you wish to delete the message, you must press **DEL** before the message ends. The display then shows **DELETED** briefly and voice says *'Message deleted. Your outgoing message is'*.

The system's pre-recorded outgoing message is then substituted and played. It will remain until you decide to record your own. Display returns to standby.

## Setting day and time

Options



Press the **OPTIONS** button until the display shows **ANS MACHINE**.

OK

Select **OK**. The display shows **MAKING LINK** then shows **ANSWER**.

Options



Press the **OPTIONS** button until the display shows **ANS SET UP**.

OK

Press **OK**. The display shows **ANSWER MODE**.

Options



Press the **OPTIONS** button again until the display shows **DAY AND TIME** alternating with the current setting, e.g. **SAT 12.01PM**.

CHANGE

Select **CHANGE**. The display shows **SAT 12.01PM**. The day flashes, indicating that it is ready to be changed. Voice says *'Please enter the day using the buttons 1 to 7, where 1 is Monday and 7 is Sunday, then press SAVE to confirm'*.

SAVE

Use the handset's keypad to enter the correct day (eg.1) and press **SAVE**. Display shows **MON 12.01 PM**. Voice says *'Please enter the time in the 12 hour clock using four digits, then press SAVE to confirm.'*

**SAVE** Use the handset's keypad to enter the correct time and press **SAVE**. Display shows (eg. 01.45) MON 01.45PM and the options: AM or PM. Voice says "Press the **AM** or **PM** button, then press **SAVE** to confirm".

**SAVE** Select AM or PM and press **SAVE**. Voice confirms day and time set and the display returns to ANSWER MODE.

### MAINS POWER FAILURE

*If the mains power fails, your Outgoing Messages and any Incoming Messages or Memos that have been recorded will be saved. However, if the mains power fails for more than about 1 second, you will need to reset the time and day announcement.*

### To set the number of rings before your Quartet 2015 answers the call

*Press buttons in order shown*

Options



At standby press **OPTIONS** until the display shows ANS MACHINE.

OK

Select **OK**. The display briefly shows MAKING LINK then shows ANSWER.

Options



Press **OPTIONS** until display shows ANS SET UP.

OK

Press **OK**. Display shows ANSWER MODE.

Options



Press **OPTIONS** until the display shows ANSWER DELAY and X RINGS. The number of rings shown is the current setting.

CHANGE

Select **CHANGE**. Display shows the current setting again: X RINGS.

SAVE

Options



Select **SAVE** to confirm setting shown or keep pressing the **OPTIONS** button to scroll through the different settings. As each new number of rings appears voice says 'Answer delay X rings' or 'Answer delay Timesaver'. Make your selection by pressing **OK**. Display immediately returns to ANSWER DELAY, showing the new setting.

OK

BACK

Wait 20 seconds or press or hold **BACK** to return to standby.

## To turn the message alert beeps on and off

Options  

At standby, press **OPTIONS** until the display shows **ANS MACHINE**.

OK

Select **OK**. The display briefly shows **MAKING LINK** then shows **ANSWER**.

Options  

Press **OPTIONS** until the display shows **ANS SET UP**.

OK

Press **OK**. The display shows **ANSWER MODE**.

Options  

Press the **OPTIONS** button until the display reads **MESSGE ALERT** flashing alternately with either **ON** or **OFF**, depending on the current setting.

CHANGE

Press **CHANGE**. Display shows **OFF** or **ON**. The setting shown is the current setting. If this is what you want, select **SAVE**.

SAVE

Options  

If you wish to change the setting, press the **OPTIONS** button and the setting will change. Voice says *'Message alert on/off'*. The display then returns to **MESSGE ALERT**, alternating with the new setting.

BACK

Press and hold **BACK** to return to standby.

## To set your remote access security code from your handset

Options  

At standby press **OPTIONS** until the display shows **ANS MACHINE**.

OK

Select **OK**. The display briefly shows **MAKING LINK** then shows **ANSWER**.

Options  

Press **OPTIONS** until display shows **ANS SET UP**.

OK

Press **OK**. Display shows **ANSWER MODE**.

Options  

Press **OPTIONS** until the display shows **SECURITY CODE** and the current three digit code. (Default code is 000.)

CHANGE

Press **CHANGE**. Display repeats the three digit code with the first digit flashing. If you wish to retain the existing code, select **SAVE**.

SAVE

If not, enter a new number, then press **SAVE**. Voice says *'Security code setting XXX'* and the display returns to **SECURITY CODE** showing the new setting.

SAVE

BACK

Wait 20 seconds or press and hold **BACK** to return to standby.

## To turn remote access on and off

*Press buttons in order shown*

Options  

At standby press **OPTIONS** until the display shows **ANS MACHINE**.

OK

Select **OK**. The display briefly shows **MAKING LINK** then shows **ANSWER**.

Options  

Press **OPTIONS** until display shows **ANS SET UP**.

OK

Press **OK**. Display shows **ANSWER MODE**.

Options  

Press **OPTIONS** until the display reads **REMOTE** alternating with **ACCESS ON**.

CHANGE

Press **CHANGE**. Display shows **ACCESS ON**.

Options  

Press the **OPTIONS** button to switch between on and off. At each option voice says '*Remote access on*' or '*off*'.

SAVE

Select the option you want using **SAVE**.

Display returns to **REMOTE ACCESS ON** or **OFF**, confirming the setting that has been selected.

BACK

Press and hold **BACK** to return to standby.

## Setting the base unit speaker volume

Options  

Press the **OPTIONS** button until the display shows **ANS MACHINE**.

OK

Select **OK**. Display briefly shows **MAKING LINK**.

Options  

Press the **OPTIONS** button until the display shows **ANS SET UP**.

OK

Press **OK**. Display shows **ANSWER MODE**.

Options  

Press the **OPTIONS** button until the display shows **BASE SPEAKER** alternating with **VOLUME HIGH, LOW** or **OFF**.

CHANGE

Select **CHANGE**. Display shows **VOLUME HI LOW** or **OFF**.

Options  

Press the **OPTIONS** button to switch between the settings. When **HIGH** is shown there is a loud beep, a softer one for **LOW** and silence for **OFF**.

SAVE

Press **SAVE** to select the one you want.

The display returns to **BASE SPEAKER** and shows the new setting.

BACK

Press and hold **BACK** to return to standby.

## To listen to your messages

When new messages have been left for you the message symbol  flashes in the top right-hand corner of the handset display, the red light also flashes and the handset beeps every 10 seconds (if message alert has been switched on, see page 27). The handset also shows the number of messages stored and the word **PLAY**.

**PLAY** Select **PLAY**. The display briefly shows **MAKING LINK** then **MESSAGE 01**. Voice says 'You have X messages. Message 1'. The message is played, then voice announces the day and time the message was left, then 'Message 2' etc.

After all messages have been played voice says 'End of messages'. The display shows **END OF MESS.**

To pause a message, press **2**. The display shows **PAUSED**. Press **2** again to resume playing.





To stop message playing and revert to standby, press **#**.

**STOP** The display returns to standby after a few seconds or immediately if you press **STOP**.

## To move through your messages



During message playback, as just described, use  and  to skip backwards and forwards through your messages.

## To delete a message during playback

During message playback the display shows **MESSAGE 01** together with 3 command options **DEL < >**.

To delete messages while you are playing through them, wait for the message to begin.

**DEL** Press **DEL** at any point after this, including during the day and time announcement.

**YES** Display shows **DELETE?** Select **YES**. Voice says 'Message deleted' and 'Message X', if there is a next message to be played.

If you change your mind and select **NO**, the message continues. The display reverts to **MESSAGE X**.

## To delete all messages at once

*Press buttons in order shown*

Wait until all messages have been played. Voice says 'End of messages.' The display shows END OF MESS and 3 options DEL <<< STOP.

DEL Press **DEL**. The display shows DELETE ALL.

YES Select **YES**.

Voice says 'All messages deleted' and the display shows DELETED before returning to standby.

The message waiting symbol  disappears.

If you do not want to delete your messages:

*Either*

STOP Press **STOP** during the END OF MESS screen.

*Or*

NO Press **NO** during the DELETE ALL screen.

In both cases the display will return to standby.

## To listen to a caller leaving a message (Call Screening)

switched on and be set to ANSWER AND RECORD (see page 23).

Incoming calls will cause the handset display to show CALL.

OK After the answering machine has answered the call, the display shows CALL SCREEN. Pressing **OK** allows the listener to hear the call but the microphone is muted.

BACK If you wish to stop listening, press **BACK**. The handset returns to standby and the message is recorded in the usual way.



If you wish to take the call, press the **TALK** button. The display shows SEC TRANS. You can now talk to the caller. The portion of the message left before you pressed the **TALK** button is recorded and tagged with day and time. The message symbol appears.

OK To Call Screen while the handset is on the charger, handset display shows CALL. Press the **OK** button before picking up the handset.

### PLEASE NOTE

*Any message not deleted will automatically be saved and stored.*



## Contacting your Quartet 2015 answering machine from another phone (remote access)

**KEYPAD** Dial your phone number.

★ When you hear your outgoing message, press the ★ button. You will hear the announcement *'Please enter your security code'*.

**CODE** Enter your security code (default 000).

If you have entered the correct code you will hear, *'You have x messages'*, and the messages are played back, with the day and time they were recorded. If there are no new messages you will hear *'You have no messages'*, then *'To hear main menu, press 1'*.

At the end of the last message, you will hear *'End of messages'*, then *'To hear main menu press 1'*.

If you enter the wrong security code the machine announces *'Incorrect security code. Please enter your security code'*. You have another chance to enter the security code. If its wrong the second time, the Quartet 2015 will end the call.

When you have accessed your answering machine, you can turn it off, play and delete messages, move backwards and forwards through your messages and re-record your outgoing message using the keypad of the phone you are using. Your Quartet 2015 will announce the command options and the corresponding number to press as follows:

*'To play all messages, press 2'*

*'To play new messages, press 3'*

*'To skip forward during messages, press 6'*

*'To delete during messages, press 5'*

*'To delete all messages, press 5'*

*'To skip back during messages, press 4'*

*'To play outgoing messages, press 8'*

*'To record a new outgoing message, press 9'*

*'To set answer on or off, press 0'*

*'To change your answer mode, press 7'*

*'To hear main menu, press 1'*

# Optional settings

The following settings can be altered on your Quartet 2015.

## To change the handset ringer melody

*Press buttons in order shown*

Options  

Press the **OPTIONS** button until the display shows the TELEPHONE.

OK

Press **OK**. Display briefly shows MAKING LINK then HANDSET RING.

CHANGE

Press **CHANGE**. Display shows MELODY.

Options  

Scroll through the options using the **OPTIONS** button. A different melody plays each time.

SAVE

Select one and press **SAVE**. Display returns to HANDSET RING.

BACK

Press and hold **BACK** to return to standby.

## To change the handset ringer volume

Options  

Press the **OPTIONS** button until the display shows TELEPHONE.

OK

Press **OK**. The display briefly shows MAKING LINK then HANDSET RING.

Options  

Press the **OPTIONS** button until the display shows HANDSET VOL alternating with VOLUME HIGH (LOW or OFF).

CHANGE

Press **CHANGE**. The display shows VOLUME HIGH (LOW or OFF).

Options  

Scroll through the options using the **OPTIONS** button. You will hear the various volume options as well as see them on the display.

SAVE

Select one and press **SAVE**. The display returns to HANDSET VOL alternating with your selected volume level.

BACK

Press and hold **BACK** to return to standby.

## To change the base unit ringer volume

Options  

Press the **OPTIONS** button until the display shows TELEPHONE.

OK

Press **OK**. The display briefly shows MAKING LINK then HANDSET RING.

Options  

Press the **OPTIONS** button until the display shows BASE RING alternating with VOLUME HIGH (LOW or OFF).

CHANGE

Press **CHANGE**. The display shows VOLUME HIGH (LOW or OFF).

Options  

Scroll through the options using the **OPTIONS** button.

SAVE

Select one and press **SAVE**. A beep sounds. The display returns to BASE RING alternating with your selected volume levels.

BACK

Press and hold **BACK** to return to standby.

## To change the dial mode

Options  

Press the **OPTIONS** button until the display shows TELEPHONE.

OK

Press **OK**. The display briefly shows MAKING LINK then HANDSET RING.

Options  

Press the **OPTIONS** button until the display shows DIAL MODE alternating with TONE.

CHANGE

Press **CHANGE**. The display shows TONE (or PULSE).

Options  

Use the **OPTIONS** button to switch between the 2 settings.

SAVE

Select one and press **SAVE**. A beep sounds and the display returns to DIAL MODE alternating with your selected dial mode.

BACK

Press and hold **BACK** to return to standby.

## To change recall mode

*Press buttons in order shown*

Options



Press the **OPTIONS** button until the display shows TELEPHONE.

OK

Press **OK**. The display briefly shows MAKING LINK then HANDSET RING.

Options



Press the **OPTIONS** button until the display shows RECALL MODE, alternating with TIMED BREAK (or EARTH).

CHANGE

Press **CHANGE**. The display shows TIMED BREAK (or EARTH).

Options



Use the **OPTIONS** button to switch between the 2 settings.

SAVE

Select one and press **SAVE**. A beep sounds. The display returns to RECALL MODE alternating with your selected recall mode.

BACK

Press and hold **BACK** to return to standby.

## NOTE

*It is recommended that on all BT lines, Dial Mode should be set to Tone and Recall Mode be set to Timed Break.*

## NOTE

*Timed Break is required for use with Select Services.*

# Using Select Services

Your Quartet 2015 is designed to make it easy for you to access certain BT Select Services, Friends & Family and Call My Bill.

The available Select Services are Call Return, Call Diversion, Reminder Call, Call Waiting, 3 Way Calling and Ring Back.

If you have any or all of these services (some do not require you to subscribe), your Quartet 2015 will help you to manage them from your handset using the *Select Services* menu.

When you start to use the *Select Services* menu, the handset will automatically take you to the last Select Service you accessed.

For information on BT Select Services, please call BT free on **0800 800 150** (residential) or **0800 800 152** (business)

## PLEASE NOTE

*If your Quartet 2015 is connected via a switchboard, the pre-programmed access to some Select Services will not be available but you can connect to the service by dialling your switchboard access code.*

*Please contact your switchboard provider if you are unsure.*

## Call Return

Using Call Return you can find out the number of the last person who called you and the date and time of the call by dialling **1471**. While on line you can return the call by dialling **3**.

## Friends & Family

This is where the telephone number of the Friends & Family service is pre-programmed into your Quartet 2015, enabling you to dial the Friends & Family service and follow the instructions from the network to add or change numbers.

## PLEASE NOTE

*Before phoning the Friends & Family service, you need your BT customer number. This is in the top right-hand corner of your phone bill.*

## Call My Bill

This feature gives you the cost of calls recorded on your telephone number since your last bill. You can get an instant bill total including all charges up to the last working day.

### PLEASE NOTE

*Before phoning the Call My Bill service, you need your BT customer number. This is in the top right-hand corner of your phone bill.*

## Call Diversion

You can use your Quartet 2015 to request the network to divert all incoming calls to another number.

Using the Quartet 2015 you can only divert all calls.

## Reminder Call

It is possible to select a Select Services option to ring you at a pre-set time, for instance, to remind you of an appointment.

## Call Waiting

The Call Waiting service lets you know when you have another caller trying to contact you while you are already on the phone. You are alerted that a call is waiting by a series of on-the-line beeps.

## Editing your Select Services

You may need to change some of your Select Services settings from time to time.

For example, Call Diversion has 3 optional access codes, **#21#**, **#61#** or **#67#**, each of which might be needed at different times. You may also want to change the divert number.

### PLEASE NOTE

*To make this type of change, you need to enter the Edit Services menu. Do not enter the Edit Select Services menu unless you are sure you wish to change your defaults.*

## 3 Way Calling

You can hold a conversation with two other external callers. You can speak to both people at the same time or choose to switch between both callers.

### VOICE PROMPTS

*When using Select Services, your Quartet 2015 display may show 'Please listen' – listen to Select Service prompts which will guide you. Please refer to your Select Service instruction book for further details.*

## To make a Call Return call

*Press buttons in order shown*

Options



Press the **OPTIONS** button until the display shows **SELECT SERVS.**

OK

Press **OK**. The display shows the last Select Service accessed.

Options



Press the **OPTIONS** button until the display shows **CALL RETURN.**

*Either*



Press the **TALK** button. The display briefly shows **MAKING LINK** then **PLEASE LISTEN**. Follow the voice prompts.

*Or*

DIAL

Press **DIAL** and follow the voice prompts.

The **CALL TIMER** then replaces the number some seconds after the number has been dialled.



To end the call press **TALK**.

### PLEASE NOTE

*If you dial the number of the person who last called, you will be charged for this call*

## To edit Call Return

**(Not to be edited unless requested by your Network Provider.)**

Options



Press the **OPTIONS** button, the display shows **SELECT SERVS.**

OK

Press **OK**. The display shows the last Select Service accessed.

Options



Press the **OPTIONS** button until the display shows **EDIT SERVS.**

OK

Press **OK**.

Options



Press **OPTIONS** until the display shows **CALL RETURN.**

CHANGE

Select **CHANGE**. The display shows the current number the handset uses to access Call Return (1471).



Using **< >** as required, edit the number displayed until it is the one you want, e.g. 1471.

SAVE

Press **SAVE**. The handset beeps and the display returns to **CALL RETURN.**

BACK

Press and hold **BACK** to return to standby.

## To call Friends & Family

*Press buttons in order shown*

Options



Press the **OPTIONS** button. The display shows **SELECT SERVS.**

OK

Press **OK**. The display shows the last Select Service accessed.

Options



Press the **OPTIONS** button until the display shows **FRIENDS/FAM.**



Press the **TALK** button or **DIAL** button. The display briefly shows **MAKING LINK** then **PLEASE LISTEN**, the Friends & Family **0800** number is then shown. The call timer then replaces the number after a few seconds.

Follow the Friends & Family voice prompts.



To end the call, press the **TALK** button.

## To set or edit Friends & Family

**(Not to be edited unless requested by your Network Provider.)**

Options



Press the **OPTIONS** button, the display shows **SELECT SERVS.**

OK

Press **OK**. The display shows the last Select Service accessed.

Options



Press the **OPTIONS** button until the display shows **EDIT SERVS.**

OK

Press **OK**.

Options



Press **OPTIONS** until the display shows **FRIENDS/FAM.**

CHANGE



Press **CHANGE**. The display shows the Friends & Family **0800** number. Edit the number if required, using the arrows to move the cursor over the digits.

SAVE

Press **SAVE**. The display returns to **FRIENDS/FAM.**

BACK

Press and hold **BACK** to return to standby.



## To call your bill

Options  

At standby, press the **OPTIONS** button. The display shows `SELECT SERVS.`

OK

Press **OK**. The display shows the last Select Service accessed.

Options  

Press **OPTIONS** until the display shows `CALL MY BILL.`



OR  
DIAL

Press the **TALK** button or **DIAL** button. The display shows the `CALL MY BILL` number being dialed and then `PLEASE LISTEN.` You are then connected to Call My Bill. Listen to the voice prompts.

The call timer then replaces the number after the number has been dialed.



Press **TALK** to end the call.

## To set or edit Call My Bill

**(Not to be edited unless requested by your Network Provider.)**

Options  

Press the **OPTIONS** button. The display shows `SELECT SERVS.`

OK

Press **OK**. The display shows the last Select Service accessed.

Options  

Press the **OPTIONS** button until the display shows `EDIT SERVS.`

OK

Press **OK**.

Options  

Press the **OPTIONS** several times until the display shows `CALL MY BILL.`

CHANGE

Select **CHANGE**. The display shows the current **0800** number for accessing Call My Bill. Edit the number if required, using the arrows to move the cursor over the digits.



SAVE

When ready press **SAVE**. The display returns to `CALL MY BILL.`

BACK

Press and hold **BACK** to return to standby.

## To set your Call Diversion setting

*Press buttons in order shown*

Options  

Press the **OPTIONS** button until the display shows SELECT SERVS.

OK

Press **OK**, then press the **OPTIONS** button until the display shows CALL DIVERT.

SET

Press **SET**. The display briefly shows MAKING LINK then PLEASE LISTEN. Follow the voice prompts.



To end the call press **TALK**.

## To cancel your Call Diversion setting

Options  

Press the **OPTIONS** button until the display shows SELECT SERVS.

OK

Press **OK**, then press the **OPTIONS** button until the display shows CALL DIVERT.

CANCEL

Press **CANCEL**. The display briefly shows MAKING LINK then PLEASE LISTEN. Follow the voice prompts.



To end the call press **TALK**.

## To edit the Call Diversion set code

Options  

Press the **OPTIONS** button, the display shows SELECT SERVS.

OK

Press **OK**. Display shows the last Select Service accessed.

Options  

Press the **OPTIONS** button until the display shows EDIT SERVS.

OK

Press **OK**.

Options  

Press the **OPTIONS** button until the display shows CALL DIVERT alternating with SET.

CHANGE

Press **CHANGE**.

Display shows the programmed code ★ 21★ for set.

Using the arrows as required enter or change the four-digit access number.

SAVE

Press **SAVE**. The display returns to CALL DIVERT alternating with SET.

BACK

Press and hold **BACK** to return to standby.

## To edit the Call Diversion cancel code

Options  

Press the **OPTIONS** button, the display shows SELECT SERVS.

OK

Press **OK**. Display shows the last Select Service accessed.

Options  

Press the **OPTIONS** button until the display shows EDIT SERVS.

OK

Press **OK**.

Options  

Press the **OPTIONS** button until the display shows CALL DIVERT alternating with CANCEL.

CHANGE

Press **CHANGE**.  
Display shows the programmed code **#21#** for cancel.

Using the arrows as required enter or change the four-digit access number.

SAVE

Press **SAVE**. The display returns to CALL DIVERT alternating with CANCEL.

BACK

Press and hold **BACK** to return to standby.

## To set or edit the Reminder Call cancel code

Options  

Press the **OPTIONS** button, the display shows SELECT SERVS.

OK

Press **OK**. The display shows the last Select Service accessed.

Options  

Press the **OPTIONS** button until the display shows EDIT SERVS.

OK

Press **OK**.

Options  

Press the **OPTIONS** button until the display shows REMINDER CALL alternating with SET or CANCEL.

CHANGE

Press **CHANGE**. The display shows **#55#**, the default setting.

KEYPAD

Using the numeric buttons as required enter the new code.

SAVE

Press **SAVE**. The display returns to REMINDER CALL. Your reminder call has been set.

BACK

Press and hold **BACK** to return to standby.

## To edit or cancel the Reminder Call set up code

*Press buttons in order shown*

Options  

Press the **OPTIONS** button, the display shows SELECT SERVS.

OK

Press **OK**. Display shows the last Select Service accessed.

Options  

Press the **OPTIONS** button until the display shows EDIT SERVS.

OK

Press **OK**.

Options  

Press the **OPTIONS** button until the display shows REMINDER CALL alternating with SET or CANCEL.

CHANGE

Press **CHANGE**. The display shows ★55★, as set previously.

KEYPAD

Using the numeric buttons as required enter the new code.

SAVE

Press **SAVE**. The display returns to REMINDER CALL. Your reminder call has been set.

BACK

Press and hold **BACK** to return to standby.

## To turn your Reminder Call ON/OFF

Options  

Press **OPTIONS** until the display shows SELECT SERVS.

OK

Press **OK**, then press **OPTIONS** until REMINDER CALL appears.

SET

Press **SET**. The display shows MAKING LINK and the REMINDER CALL.

*or*

CANCEL

Press **CANCEL**. The display shows MAKING LINK and the REMINDER CALL. The number is dialed.

The display shows PLEASE LISTEN. Follow the voice prompts.

The network voice confirms the setting or cancellation.



To end the call, press **TALK**.

## To turn Call Waiting ON/OFF

Options



Press **OPTIONS** button until the display shows **SELECT SERVS.**

OK

Press **OK**. Press the **OPTIONS** button until the display shows **CALL WAITING**.

ON

Press **ON** or **OFF**. The display shows **MAKING LINK** followed by **PLEASE LISTEN** and your setting is confirmed by the voice.



To end the call press **TALK** or return the handset to the base unit.

## To edit the Call Waiting code

**(Not to be edited unless requested by your Network Provider.)**

Options



Press the **OPTIONS** button. The display shows **SELECT SERVS.**

OK

Press **OK**. The display shows the last Select Service accessed.

Options



Press the **OPTIONS** button until the display shows **EDIT SERVS.**

OK

Press **OK**.

Options



Press the **OPTIONS** button until the display shows **CALL WAITING** alternating with **ON**.

Options



Press the **OPTIONS** button until the display shows **CALL WAITING** alternating with **OFF**.

CHANGE

Select **CHANGE**. The display shows the current setting, either **\*43#** for **ON** or **#43#** for **OFF**.



Using the  as required to enter or edit the code as required.

SAVE

When ready press **SAVE**. The display returns to **CALL WAITING** alternating with your chosen setting.

BACK

Press and hold **BACK** to return to standby.

# Using additional handsets

You can register more than one handset on your Quartet 2015 base unit; the maximum is 4.

## To register an additional handset

*Press buttons in order shown*

Charge the handset for 24 hours.  
The handset display will show



**YES** Press **YES**. The display shows **HANDSET X**, with **X** flashing.

**KEYPAD** Enter the number of the handset to be registered. If yours is the second of two, enter **2**, if the first, enter **1** etc.

**OK** Press **OK**. The display reads **PRESS BASE BUTTON**.

Press the **BLACK** button on the base unit.

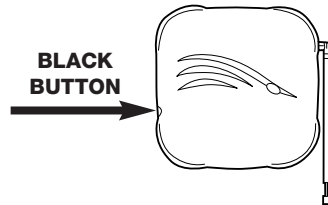

A double beep sounds and the display returns to standby. Your handset is now registered to the Quartet 2015 base unit.

## To transfer a call to another handset

You are Handset 1 and have taken an incoming call and wish to transfer it to another Quartet 2015 handset that is registered to your base unit.

*During the call*

**TRANS** Press **TRANS**. The display shows **( )** and **TRANSFER X**, where **X** is the number of one of the registered handsets.

**KEYPAD** Enter the number of the handset you wish to transfer the call to (**2, 3, 4**).

**OK** Press **OK**. The display shows **HANDSET 1** and **(->)**.

 Press **TALK** or return the handset to the base unit. Your call has been transferred.

The display returns to standby.

## To register your handset to another Quartet 2015 base

If you want to re-register the handset on another Quartet 2015 unit – then the handset needs to be completely reset. This is done by pressing the **VOLUME** button and the **REDIAL** button together until the display shows **RESET**. This may take up to 3 seconds.

VOL

Redial

OK Press **OK** to confirm.

You may then follow these instructions for registering an additional handset.

The handset display will show



YES Press **YES**. The display shows **HANDSET X**, with **X** flashing.

KEYPAD Enter the number of the handset to be registered. If yours is the second of two, enter **2**, if the first, enter **1** etc.

OK Press **OK**. The display reads **PRESS BASE BUTTON**.

Press the **BLACK** button on the base unit.

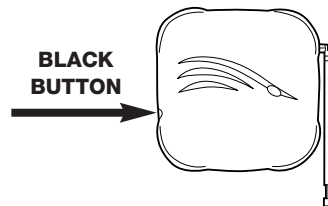

A double beep sounds and the display returns to standby. Your handset is now registered to the Quartet base unit.

### NOTE

*If the handset is reset the Directory memories will be erased and the handset options will return to their default settings.*

# Wall mounting

Your BT Quartet 2015 can be wall-mounted using the screws and wall plugs provided. Use the wall-mounting template opposite as a guide for the drill holes.

Before you wall-mount your Quartet 2015 or handset charger (or both), check that:

- The wall can support the weight of the apparatus.
- The position you choose leaves enough space for the unit to clear any obstruction on the wall with the aerial extended, such as a shelf.
- The positioning gives you sufficient radio coverage. Avoid mounting the units near large metal objects and minimising the amount of walls between the base unit and the handsets.

## To wall-mount the Quartet 2015 base unit

- 1** Using a pencil, mark the place on the wall where you wish to place the screws using the wall-mounting template on page 53.
- 2** Drill two holes suitable for the screws and wall plugs supplied (if required).
- 3** Drive the screws into the wall, leaving about 5 mm free on which to hang the Quartet 2015.
- 4** Position the power and telephone cords down through the grooves before you hook the unit on the screws.

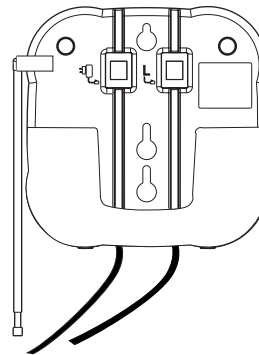



## To wall-mount the handset charger

- 1 Using a pencil, mark two holes on the wall *48mm* apart in the position you want to mount your charger.
- 2 Drill two holes with a drill bit suitable for the screws and wall-plugs supplied (if required).
- 3 Drive the screws into the wall, leaving about 9mm free on which to hang the charger.
- 4 Remove the back panel of your handset charger as shown.

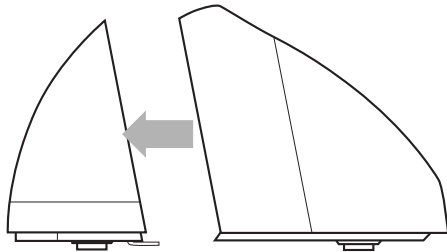

- 5 If you wish, you can rotate the back panel round and attach it to the bottom of the charger.

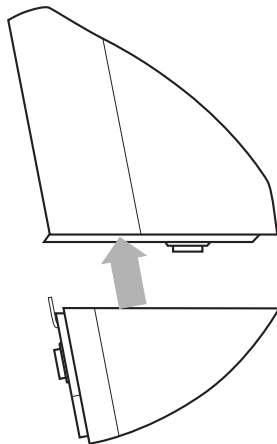

- 6 Press the power cord into its guide groove before you hook the unit on the screws.

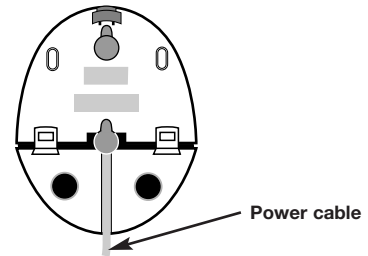

- 7 Hook the holes on the back of the charger over the screws heads in the wall.

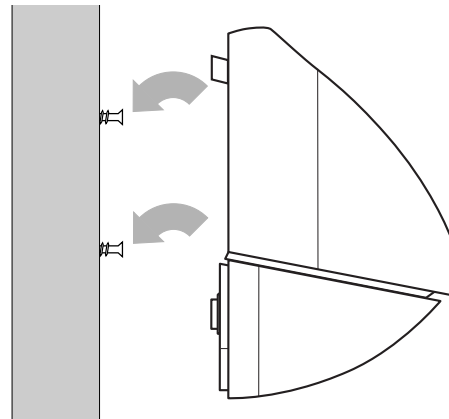

# Help and advice

If you have any difficulty using your Quartet 2015, look in this section first for solutions to the most common problems

## **No dialling tone**

Make sure the telephone lead is plugged into the telephone socket at the back of the Quartet 2015 and that the telephone lead is connected to your wall socket. Check that no other extension is in use.

Make sure that you are within range of the Quartet 2015 base unit. Move closer and try again.

## **Phone does not ring**

Check that the handset ringer volume is not switched off.

Check that no other connected phones are off hook.

Check whether you have too many phone extensions in your home or office. For help with this, please refer to the section '*How many phones can you have?*' in Technical advice on page 50.

BT can supply a REN booster to support up to 8 separate pieces of equipment connected to your line.

## **Cannot get through, even though dialling tone can be heard**

You may be set to the wrong Dial Mode (Tone or Pulse). Check to see that it is correct for your use.

Batteries may be low, ensure that they are charged

## **Handset beeps**

You have new messages recorded on your answering machine. Play them, and the beeping will stop. If you do not wish to hear beeps when you have new messages, you can turn off the message alert beeps.

Your handset may be out of range and you will need to move closer to the base unit.

Batteries may be low, ensure that they are charged

## **I have no answer machine messages**

Check that your answering machine is switched on. There should be  on your display.

Check that your answering machine is set to Answer and Record mode.

## **Reception is poor during a call**

You may need to change the channel. You can do this during the call.

Your handset may be out of range and you will need to move closer to the base unit.

## **Pre-programmed Select Services do not work**

### **BT Services Information**

**Freefone 0800 800 150** (*residential customers*).

**Freefone 0800 800 152** (*business customers*).

## BT Helpline 08457 697330

*Please call the BT Helpline (local call rates) if you need further assistance with your BT Quartet 2015. Please have your Quartet 2015 Serial Number ready when calling the Helpline. For your convenience please enter the Serial Number, place and date of purchase on Page 5 of this user guide.*

## Emergency services

The emergency services can be contacted in the UK by dialling 999. You may also dial 112, which is valid in any country that is a member of the European Community.

In certain situations you may not be able to make an emergency call:

- If the telephone line is disconnected.
- If there is a line fault, whether on your phone or in the network.
- If there is a power failure.

If your BT Quartet 2015 is connected to a PBX (switchboard), you may have to dial an access number before entering 999 to contact the emergency services.

It is recommended that alternative arrangements are provided to enable you to make emergency calls during a mains power failure.

## Safety instructions



Use only the power adaptor supplied and the handset battery pack supplied. Spare batteries – Item Code: 870461 – are available from BT Shops.



There is a slight chance that your phone could be damaged by an electrical storm. We recommend that you unplug your Quartet 2015 from the mains power and telephone line socket during storms.



The Quartet 2015 base unit, handset and charging units produce a small amount of heat during use. Therefore, we advise against placing these products on antique, veneered or wooden surfaces as damage may occur.



Do not use your Quartet 2015 in damp, humid conditions such as bathrooms.

# Technical advice

## Environment

Your BT Quartet 2015 should be kept free of dust, moisture, high temperature and vibration, and it should not be exposed to direct sunlight. It should not be used in bathrooms or near water.

Your Quartet 2015 is designed to be operated in a normal office or domestic environment only, where the relative humidity is no more than 60%.

## Maintaining your Quartet 2015

Clean with a soft, dry cloth, do not use a damp cloth.

Do not use abrasive materials, solvents or aerosol cleaners as these may damage the unit. Do not place on untreated antique furniture.

## How many phones can you have?

Although you may have any number of sockets, it is important to limit the number of phones and other pieces of apparatus connected in order to ensure that each phone will ring.

All telephone equipment has a Ringer Equivalence Number (REN), which is used to calculate how many pieces of apparatus may be connected to any one telephone line.

Telephones provided by BT have a REN of 1, unless otherwise stated on the underside of the phone. Even where the number of telephones has been limited, there is no guarantee that different types of phone on the same line will ring, even when the REN is less than 4.

You must not connect more than 4 products to a single line.

## Network connection information

Your Quartet 2015 is designed to work with both BT and other UK networks, including cable.

Although this equipment can use either Loop Disconnect (Pulse) or DTMF (Tone) signalling, the performance of the DTMF (Tone) signalling is subject to regulatory requirements for correct operation. It is therefore strongly recommended that your equipment is set to use DTMF (Tone) signalling for access to public or private emergency services.

DTMF signalling also provides faster call set-up.

Advice on connection to BT systems can be obtained by dialling BT **Freefone 0800 800 152**.

## Guarantee

**If you own your BT Quartet 2015 and it is under BT's guarantee, BT guarantees the product for one year, provided that:**

The goods have only been used for their intended purpose, and have not been subjected to misuse or been wilfully or accidentally damaged.

The goods have not been tampered with or repaired by anyone other than BT, its staff or its agents.

If a fault does occur, and you bought the unit yourself, it will be repaired or replaced free of charge, provided you return it to where you purchased it and produce your receipt.

The terms and conditions of this guarantee do not affect your statutory rights.

**If you own your BT Quartet 2015, but the guarantee period has expired:**

If your BT Quartet 2015 needs repair after the guarantee period has ended, it must be repaired so as to remain compliant with the approval requirements for connection to the telephone network.

For details of BT's recommended repair agents, please call BT free of charge on **Freefone 0800 800 150**, or visit your nearest BT shop.

# Index

Additional handsets	<b>44</b>	Keypad guard	<b>13</b>	Ring delay	<b>26</b>
Aerial	<b>7</b>	Mains power socket	<b>6</b>	Ringer Equivalence Number (REN)	<b>50</b>
Answer mode	<b>23</b>	Maintenance	<b>50</b>	Ringer melody	<b>32</b>
Answering Machine	<b>19</b>	Making calls	<b>12</b>	Safety Instructions	<b>49</b>
BT Services Information	<b>48</b>	Memos	<b>22</b>	Secrecy	<b>15</b>
Call Diversion	<b>40, 41</b>	Menu options	<b>8</b>	Select Services	<b>35</b>
Call My Bill	<b>39</b>	Menu structure	<b>10, 11</b>	Setting up	<b>6</b>
Call Return	<b>37</b>	Message alert on/off	<b>27</b>	Store an entry	<b>16</b>
Call Screening	<b>30</b>	Messages		Symbols	<b>9</b>
Call Waiting	<b>14, 43</b>	Delete all	<b>30</b>	Technical Advice	<b>50</b>
Channel seeker	<b>14</b>	Delete individual	<b>29</b>	Telephone wall socket	<b>6</b>
Charging handset batteries	<b>7</b>	Listen	<b>29</b>	Three way calling	<b>15</b>
		Move through	<b>29</b>	To view a number before dialling	<b>12</b>
Day and time	<b>25</b>	On and off	<b>22</b>	Transfer calls	<b>44</b>
Delete an entry	<b>18</b>	Optional Settings	<b>32</b>	Viewing an entry	<b>18</b>
Dial mode	<b>33</b>	Outgoing message	<b>25</b>	Volume, base station	<b>28</b>
Directory	<b>16</b>	Recall mode	<b>34</b>	Volume, handset	<b>15</b>
Edit an entry	<b>17</b>	Receiving calls	<b>13</b>	Wall Mounting	<b>46</b>
Emergency Services	<b>49</b>	Recording a new outgoing message	<b>24</b>	Template	<b>53</b>
Ending calls	<b>12</b>	Redialling the last number	<b>13</b>		
Environment	<b>50</b>	Registering	<b>44</b>		
Friends & Family	<b>38</b>	base unit	<b>45</b>		
Guarantee	<b>51</b>	Reminder Call	<b>41, 42</b>		
Help and Advice	<b>48</b>	Remote access	<b>28</b>		
Helpline	<b>49</b>	Remote access security code	<b>27</b>		
		Ring back	<b>14</b>		

# *Wall mounting Template*

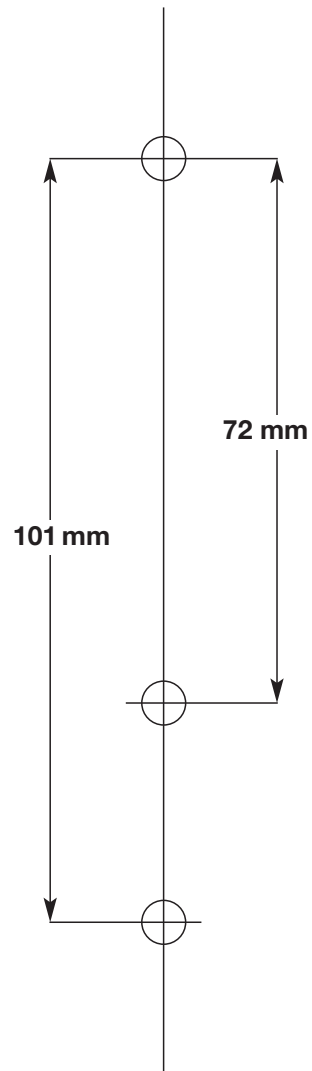







*Offices in Europe, North America,  
Japan and Asia Pacific.*

The telecommunications services described in this publication are subject to availability and may be modified from time to time. Services and equipment are provided subject to British Telecommunications plc's respective standard conditions of contract. Nothing in this publication forms any part of any contract.

*Touchtone*™ is a registered trade mark of British Telecommunications plc in the UK.

© British Telecommunications plc 1998.  
Registered Office: 81 Newgate Street, London EC1A 7AJ.  
Registered in England No. 1800000.  
Printed in Thailand. Quartet 2015 Issue 1 (11/98) 7  
Designed by The Art & Design Partnership Limited.



CE compliant to 89/336/EEC  
(EMC Directive) & 73/23/EEC  
(Low Voltage Directive)

