

SmartRad Planning Manual

Issue 1 – 15 April 2010

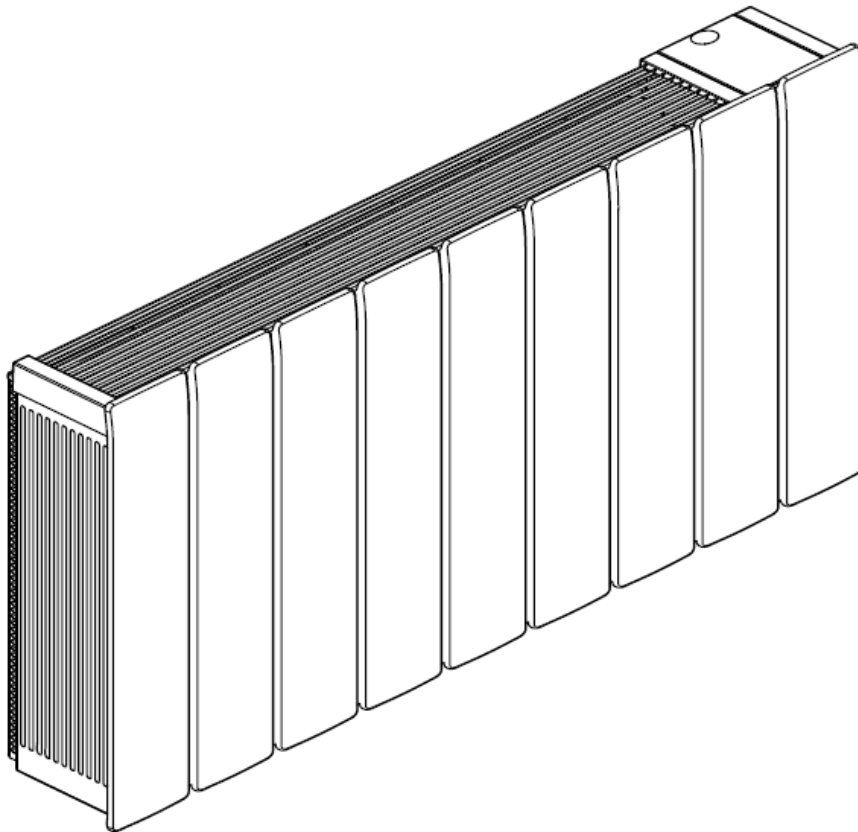

Dimplex SmartRad Fan Convectector

Models SRX80, SRX120, SRX140 & SRX180

Applies to models with White Glass, Black Glass and Metal facias

Contents

1	Introduction to the SmartRad.....	4
2	Benefits of the SmartRad.....	4
2.1.1	Smaller dimensions.....	4
2.1.2	Low flow temperature.....	4
2.1.3	Lower Water content.....	5
2.1.4	Rapid heat up.....	5
2.1.5	Fast Reacting.....	5
2.1.6	Less stratification.....	5
2.1.7	Low surface temperature.....	6
3	SmartRad Specification.....	7
3.1	Technical and performance data.....	7
3.2	Electrical specification.....	8
3.3	Hydraulic connection.....	8
3.4	Pressure Losses.....	9
3.5	SRX Outputs (Watts).....	10
3.6	Output adjustment for different flow rates.....	11
4	Accessories.....	11
4.1	Filter set SRX FS.....	11
4.2	Plug in timers.....	11
5	Installation Considerations.....	12
5.1	SmartRad positioning.....	12
5.2	System Balancing.....	12
5.3	Wall Mounting.....	12
5.4	Water Connection.....	13
5.5	Corrosion inhibitors.....	14
5.6	Electrical Connection.....	14
6	Typical applications.....	15
6.1	Whole house.....	15
6.2	SmartRads mixed with Radiators.....	15
6.3	SmartRads mixed with under floor heating.....	15
6.4	Ground Source heat pumps.....	15

Controls and Control strategies	16
6.5 Mixed SmartRad and Radiator circuits	16
6.6 Boiler interlock	16
6.7 SmartRad controls.....	16
6.8 Central system control	16
6.9 Individual SmartRad control Plug in controllers	17
6.10 Spring and autumn operation	17
6.11 Summer operation	17
6.12 Pump optimisation.....	17
7 Designing the system for Maximum Efficiency.....	18
7.1 Choosing a Mean Water Temperature (MWT)	18
7.1.1 Suggested MWT	18
7.1.2 Air off temperatures	18
7.2 Weather compensation	18

1 Introduction to the SmartRad

The SmartRad is a stylish and modern alternative that out performs traditional radiators. At the heart of the SmartRad is a heat exchanger with a large surface area, which allows effective transfer of heat into the room even at low flow temperatures. To increase the amount of heat output there is an energy efficient fan which forces air over the heat exchanger. By being able to give a decent heat output at low flow temperatures, the SmartRad makes it even more viable to install heat pumps when refurbishing a property.

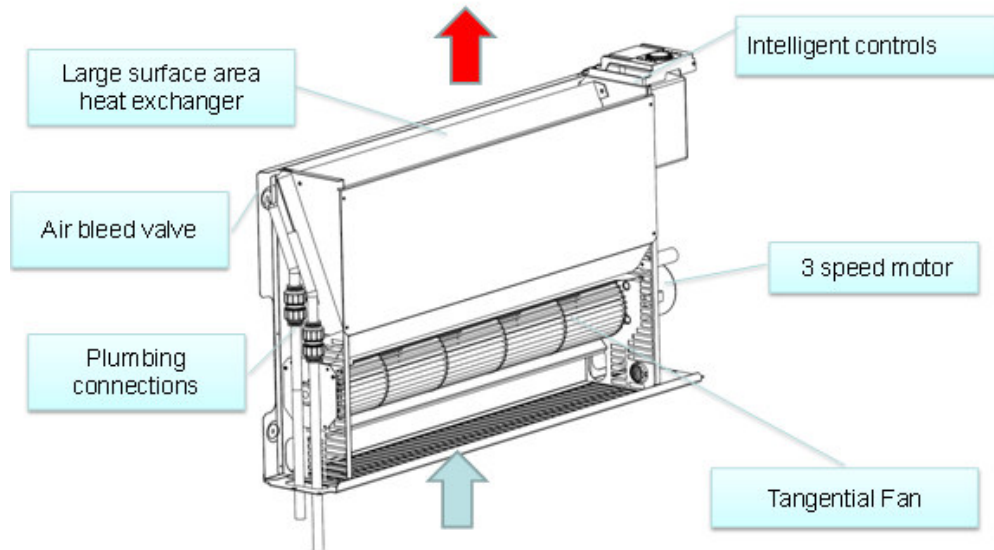

2 Benefits of the SmartRad

Thanks to the heat exchanger and fan the increased heat output means that the SmartRad takes up less wall space compared to a standard radiator when operating under the same conditions. The following examples demonstrate the benefits of the SmartRad over traditional radiators.

2.1.1 Smaller dimensions

A Radiator with dimensions of 530x911mm would need to have a Mean Water Temperature (MWT) of 73°C to give an output of 1kW whilst the SmartRad would only need a MWT of 40°C to give the same 1kW output. This means the system can be run at significantly lower flow temperature which will give significant savings in system efficiency.

2.1.2 Low flow temperature

As shown in Figure 1 a standard radiator operating at a flow temperature of 40°C would need to measure 530x3128mm whilst

Figure 2 shows that the SmartRad would only need to be 530x911mm – that is over 3½ times smaller. Therefore, by using the SmartRad it becomes practical to fit the product into a room and still operate at lower flow temperatures.

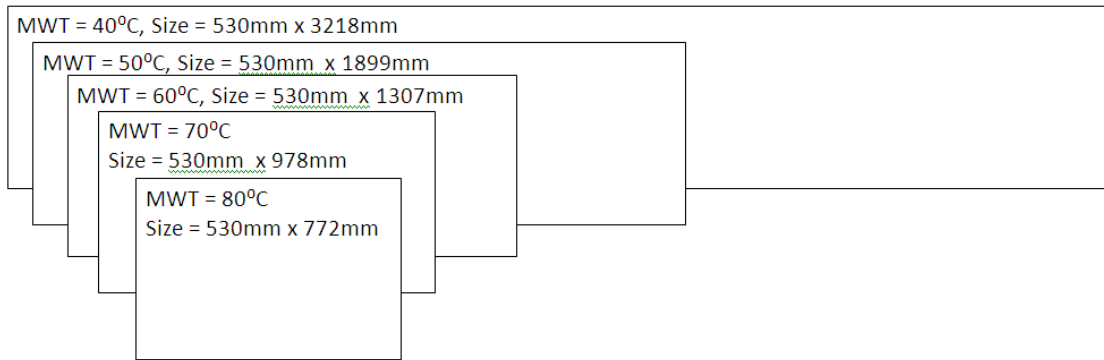

Figure 1: Radiator sizes based upon a “Double convection” design with an output of 1537W

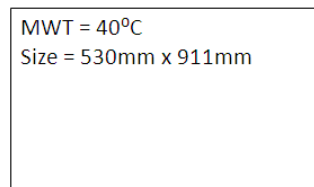

Figure 2: SmartRad size based upon fan speed 2 setting with an output of 1537W.

2.1.3 Lower Water content

The SmartRad contains only a fraction of the water compared to a traditional radiator. A traditional 1kW radiator operating at a flow temperature of 73°C could contain up to 35 litres of water, whereas the SRX180 gives a 1kW output when operating at only 40°C but contains only 0.6 litres – that is over 50 times less water.

2.1.4 Rapid heat up

The low water content makes the SmartRad highly reactive, when the heating demand increases the heat pump only has to heat a small volume of water to 40°C. However with a radiator the boiler would have to heat the 35 Litres of water to 73°C.

2.1.5 Fast Reacting

The low water content is also beneficial if the heating demand is suddenly decreased if for example there is suddenly a solar gain. With a radiator the large thermal mass will stubbornly keep emitting heat even though the room is up to temperature, however with a SmartRad the fan will modulate its speed down and the low thermal mass will quickly cool down meaning that the room is not over heated.

2.1.6 Less stratification

With a traditional radiator, the high water flow temperature means that the air off temperatures is high causing a ‘chimney’ effect as the hot air rushes to the ceiling but leaving the floor area cold. The air in the region around the thermostat is at the correct temperature but the average room temperature is in fact higher. A lot of heat is lost into the ceiling and though the upper part of the walls.

With the SmartRad the lower water flow temperatures and increased mixing of the air by the fan mean that there is less temperature stratification, meaning that the average room temperature is in fact lower, meaning there is less heat loss to the ceiling and upper walls. The lower heat loss translates into lower heating bills and a more comfortable climate for the end user.

2.1.7 Low surface temperature

Due to the heat exchanger being installed inside the cover it is possible to pass high temperature water through the SmartRad without the casing getting above 43°C. This means that the product could replace a standard high temperature radiator in places such as Nurseries and Care homes. Please note that full testing and approvals have not been completed yet.

3 SmartRad Specification

3.1 Technical and performance data					
	Fan Speed	SRX080	SRX120	SRX140	SRX180
Fan Power Consumption (W)	3	25-27	43-47	56-60	50-53
	2	19-20	29-32	36-40	33-35
	1	16-17	20-22	24-26	23-24
Air Flow rate (m ³ /h)	3	228	345	410	540
	2	125	190	225	300
	1	60	100	120	160
Sound Level @ 1m dB(A)	3	36	36	36	36
	2	29	29	29	29
	1	26	26	26	26
Water Content (l)		0.31	0.43	0.48	0.60
Length (mm)		503	670	740	911
Height (mm)		530	530	530	530
Depth (mm)		145	145	145	145
Installed weight (kg) – White metal front	Not currently available at time of print.				
Installed weight (kg) – White glass front					
Installed weight (kg) – Black glass front					
Installation	wall mounted				
Water protection of housing	IP X0				
Front Panel	White metal front White Glass front Black Glass front				
Rear Panel	Metal				
Approvals and certification	CE declaration of conformity Conforms to EN 55014, EN 61000-3-2, EN 61000-3-3				

3.2 Electrical specification					
Dimplex product name		SRX080	SRX120	SRX140	SRX180
Nominal voltage (V)		~ 230-240			
Fuse rating (A)		3A	3A	3A	3A
Power Cable		4 core cable each with cross section of 0.75mm ² , (live, neutral, earth and black wire for “pilot wire function”) usable length 1m,			
Electrical Power Consumption (W)	Speed 3	25-27	43-47	56-60	50-53
	Speed 2	19-20	29-32	36-40	33-35
	Speed 1	16-17	20-22	24-26	23-24
	PCB only	1	1	1	1

3.3 Hydraulic connection	
Flow and return pipes	15mm copper pipes 50mm between middle of flow and return pipes
Air bleed valve	Air bleed valve on the top of the heat exchanger
Typical flow rate (l/h)	Typical 150l/h (can range from 100 l/h to 450 l/h)

3.4 Pressure Losses

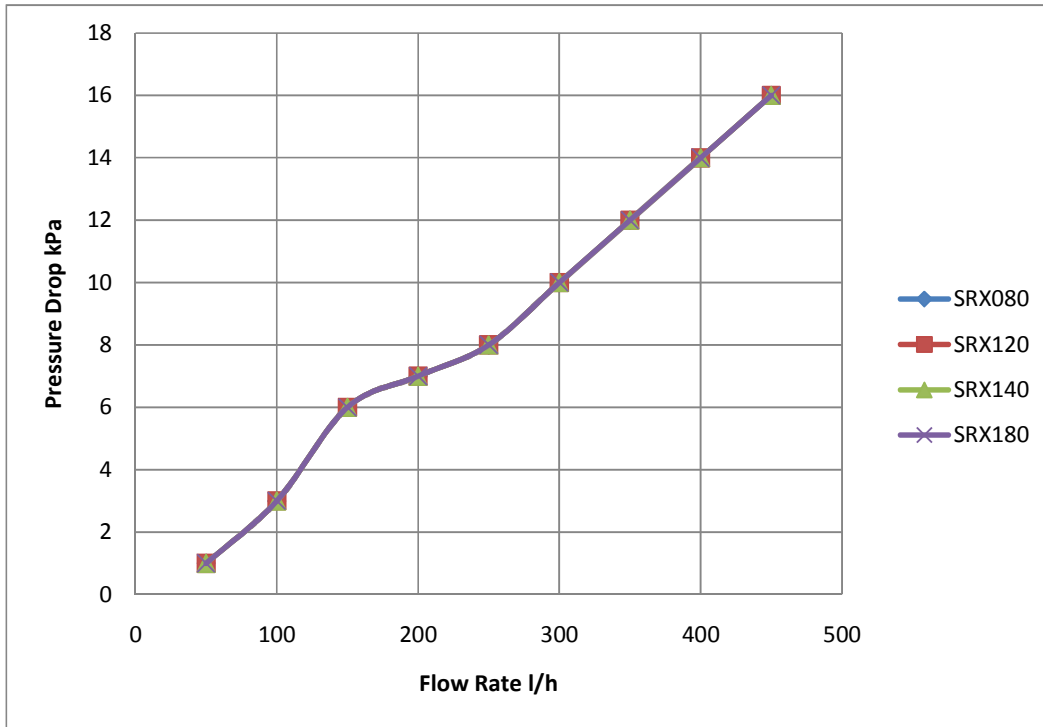

Figure 3: Pressure losses and various flow rates

Note: these pressure drops are only indicative. Each of the SmartRads have a different heat exchanger and therefore a different pressure. Figure 3 will be updated with the correct information when it is available.

3.5 SRX Outputs (Watts)

Inlet air temperature of 20°C and a water flow rate of 150 l/h

	Mean Water Temp °C	SRX080	SRX120	SRX140	SRX180
Speed 3	30	485	730	854	1088
	33	613	923	1079	1375
	35	741	1115	1304	1662
	38	869	1308	1530	1949
	40	996	1500	1755	2236
	43	1124	1693	1980	2523
	45	1252	1885	2206	2810
	48	1380	2078	2431	3097
	50	1508	2270	2656	3384
	53	1635	2463	2882	3671
	55	1763	2655	3107	3958
	58	1891	2848	3332	4245
	60	2019	3041	3558	4532
	63	2147	3233	3783	4819
65	2274	3426	4008	5106	
Speed 2	30	314	401	551	718
	33	394	521	693	903
	35	474	640	835	1088
	38	554	759	977	1273
	40	634	878	1119	1457
	43	714	997	1261	1642
	45	794	1117	1403	1827
	48	874	1236	1545	2012
	50	954	1355	1687	2197
	53	1034	1474	1829	2382
	55	1114	1593	1971	2567
	58	1194	1713	2113	2752
	60	1274	1832	2255	2936
	63	1354	1951	2397	3121
65	1434	2070	2539	3306	
Speed 1	30	163	271	323	423
	33	204	339	405	530
	35	245	408	487	637
	38	286	476	569	745
	40	327	545	650	852
	43	368	613	732	959
	45	409	682	814	1067
	48	450	750	896	1174
	50	491	819	977	1281
	53	532	887	1059	1389
	55	573	956	1141	1496
	58	614	1024	1223	1603
	60	655	1093	1305	1711
	63	696	1161	1386	1818
65	737	1230	1468	1925	

3.6 Output adjustment for different flow rates

The output of the SmartRad is affected by the flow rate of water through the heat exchanger even if the Mean water temperature remains the same. The performance of the heat exchanger changes with flow rate due to increased heat transfer when the flow becomes more turbulent. For most instances 150l/h is the most suitable however a conversion factor can be used to adjust the heat output for different flow rates.

Flow Rate l/h	Adjustment Factor
50	0.87
100	0.93
150	1.00
200	1.04
250	1.06
300	1.09
350	1.10
400	1.10
450	1.10

4 Accessories

4.1 Filter set SRX FS

Filter set can be clipped to the air inlet grill of the SmartRad. The filter is easily cuttable in order to fit all four sizes. The filter will slightly restrict the air flow meaning that the heat output will be slightly reduced.	
Dimensions of unit (W x H x D) mm	This information is not currently available. Please speak to your Dimplex representative for more information.
Factor to calculate the power output reduction	
Factor to calculate the air flow reduction	

4.2 Plug in timers

RX24Ti	24 hour programmable timer allowing each SmartRad to be configured to its own individual time program
RXRBTi	Electronic runback timer ideal for controlling running costs allowing the heater to only operate for a set period each time the controller is activated.

5 Installation Considerations

5.1 SmartRad positioning

In many instances the position of the SmartRad will already be dictated by the design of the room. Consideration must however be given to avoid:

- Fixing the product near curtains or other materials that are light weight and could be moved in the air current created by the fan.
- Installation in an environment where dirt, dust or pet hair could be sucked into the product and block the air flow.
- Installation immediately above or below a fixed socket outlet or connection box.
- In a location where the risk of water entering the product is possible for example bath rooms and kitchens.

5.2 System Balancing

It is essential that there is adequate flow through each of the SmartRads. Balancing valves are not supplied with the product.

5.3 Wall Mounting

The appliance should be securely mounted to the wall to minimise the possibility of noise transmission.

Model	A	B	C	D
SRX080	503	324	396	386
SRX120	670	492	564	564
SRX140	740	562	634	624
SRX180	911	732	804	794

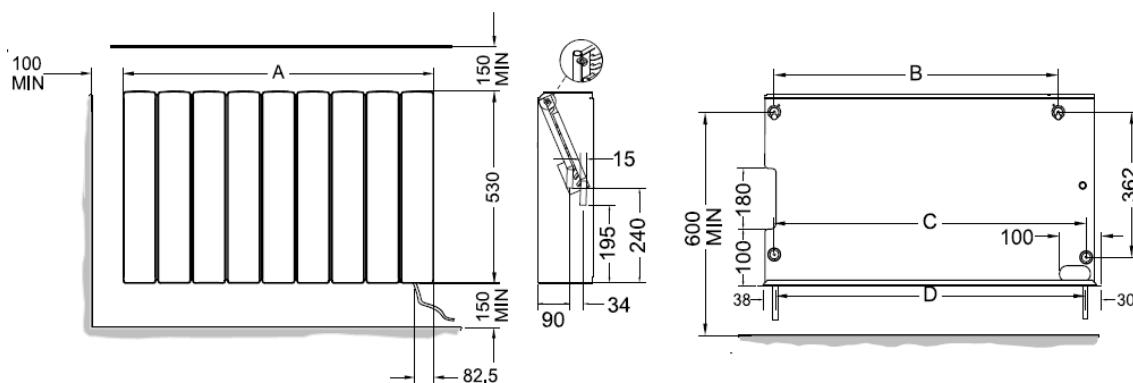

Figure 4: Product and installation dimensions

5.4 Water Connection

There are a number of different plumbing options which the installer can adapt depending on the project as shown in Figure 5. The inlet and outlet pipes on the heat exchanger are plain 15mm pipe. Note that on the left hand side of the product the pipes pass in front of each other but on the right hand side pass side by side as shown in Figure 6.

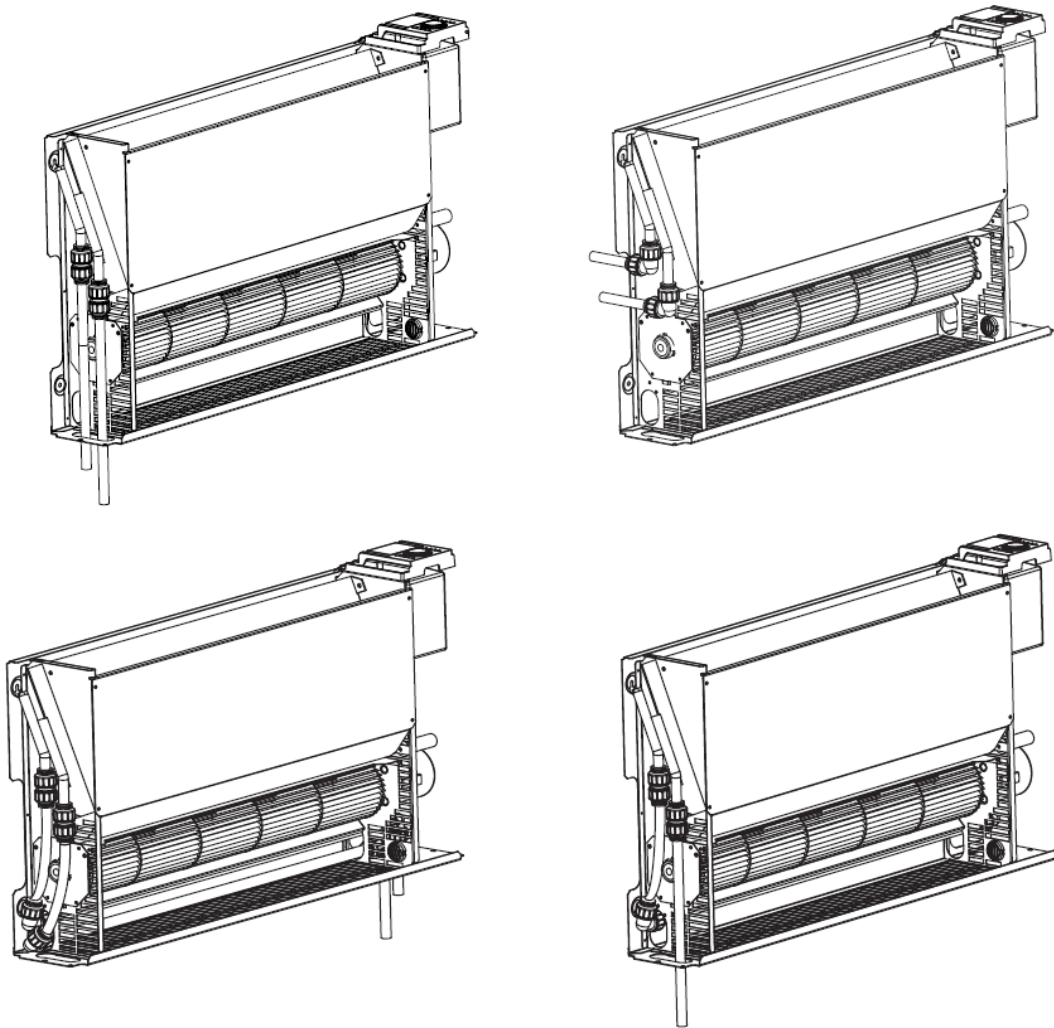

Figure 5: Possible routes for piping

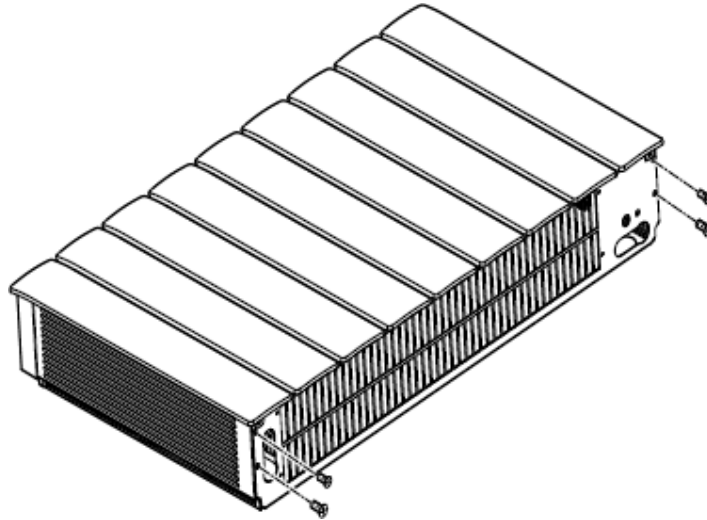

Figure 6: Note the different orientation of the flow and return pipes on the LHS and RHS.

5.5 Corrosion inhibitors

The use of anticorrosion inhibitors is permitted with SmartRad. A general rule is that SmartRad system should be given the same protection as a wet radiator system.

5.6 Electrical Connection

The SmartRad requires a connection to the mains power supply via a junction box fixed close to the product. In addition to the Live, Neutral and Earth cables, the SmartRad has a 'pilot wire' and can be used with optional plug in modules to communicate between the heaters.

If the black 'pilot' wire is not being used it should be isolated in accordance with IEE wiring regulations. When the pilot wire is switching to set back it becomes energised at 240V although at a low current. Where pilot wires are installed separately from the heater circuitry they should be protected, double insulated and carry their own integral earth continuity conductor. For more information see the "Electrical Specification" .

6 Typical applications

The SmartRad is highly versatile; it can be used in conjunction with radiators or in conjunction with under floor heating. In all cases it is important to ensure that there is always an adequate flow of hot water at the correct temperature through the SmartRad throughout the entire heating season. In a domestic installation it is typical to have all the heat emitters sized based upon the same mean water temperature.

6.1 Whole house

SmartRads are ideal if the installer is aiming to reduce the flow temperature as low as possible, but it is not practical to install under floor.

6.2 SmartRads mixed with Radiators

It is possible to combine standard radiators and SmartRads in the same installation. This is particularly common if the radiators in some rooms are too large or the number of radiators in each of the rooms needs to be reduced for aesthetic reasons. Special care needs to be taken to ensure that there is the correct flow rate through the radiators and SmartRads.

6.3 SmartRads mixed with under floor heating

Under floor heating typically operates at low flow temperatures to maximise the efficiency of the heat pump or boiler. In many houses it is not practical to install under floor heating upstairs. If the installer wanted to install radiators upstairs it would be necessary to increase the flow temperature in order to get enough heat out of the radiators, this would mean that a second heating circuit would have to be installed and the temperature mixed down to make it cool enough for the under floor.

By installing the SmartRads upstairs, there is no need to install a second heating circuit as the SmartRads can operate at the same temperature as the under floor system. Typical MWT should be higher than 40°C to prevent air off temperature from the SmartRad feeling too cold.

6.4 Ground Source heat pumps

When installing the SmartRad extra care must be given to the running hours and sizing of the ground source heat pump. If the heat load is larger than expected the ground source heat pump will attempt to draw more heat from the ground than is available. This situation could occur if the SmartRad is sized to run on a low fan speed during the design stage but the heat load for the area is much higher in practice and the SmartRad is actually run on a higher fan speed drawing more heat from the system than expected.

Controls and Control strategies



Figure 7: SmartRad controls

6.5 Mixed SmartRad and Radiator circuits

It is permissible to place radiators and SmartRads on the same heating system however the flow rates and MWT through each product should be considered to ensure that they give the desired output. It will be necessary to correctly balance the system.

6.6 Boiler interlock

It is a requirement under the building regulations that all boilers should have interlock. i.e. a method of minimising system operation if there is no heating requirement.

6.7 SmartRad controls

There is a temperature coil installed on the water coil that measures its temperature. The sensor prevents the fan from running if the MWT is less than 2°C warmer than room temperature or if the water is cooler than 14°C. If the water temperature is too low this will be indicated by the power light flashing. This feature has 3 benefits:

- Prevents the fan from running if there is no heat available from the heating system. This prevents cold air being blown around the room and also allows the SmartRad to be “disabled” centrally when there is no flow through the product by turning off the pump.
- Prevents the SmartRad from taking more heat from the system if the water temperature is lower than 14°C. This means that an air source heat pump will always have enough energy to perform a defrost.

6.8 Central system control

The SmartRad is automatically disabled after a short time when there has been no flow through the product. This is achieved because when the circulating pump is switched off, the flow in the SmartRad will stop and its temperature starts to drop. The fan will be disabled once the water in the fan coil has cooled within 2°C of room temperature. As soon as the temperature rises above 2°C the fan will be enabled again.

This means that the entire heating system can be enabled by a central timer clock which controls a circulating pump. The added advantage of SmartRad over radiators with TRVs is that the thermal mass of the SmartRad is much lower so therefore less heat is wasted when the system is turned off.

6.9 Individual SmartRad control Plug in controllers

There may be times when it is desirable for some areas of the property to be heated and others not to be heated. This can be achieved by having the central pump running and installing timers on the SmartRad in areas where no heating is required. With the plug in timers, there is still flow through the water coil, however, because the fan is not running the heat emitted is very low.

In addition to control system already on the SmartRad controllers extra optional controllers can be fitted for increased control. This would be an ideal way to minimise running costs if not all parts of the building are occupied all of the time.

6.10 Spring and autumn operation

When the weather starts improving, there will become times in the day when heating is no longer required. If weather compensation is enabled on the heat pump this will moderate the flow temperature to ensure that heating is only supplied when it is needed. During times when heating is not required for short periods it is best to leave the power on so that the SmartRad can control things correctly. The advantage of leaving the SmartRads turned on is that the plug in timer cassettes will retain their settings.

6.11 Summer operation

When the weather has improved sufficiently so that the heat pump or boiler can be switched off or placed into “Summer mode”, the SmartRads can also be switched off. If the SmartRads are left in standby they have been designed to use very little power. Leaving them switched on during the summer has the added benefit that they will not lose their timer settings and no one will need to remember to turn them on again when the weather gets colder.

6.12 Pump optimisation

For the majority of installations it is not recommended to use Pump Optimisation with the SmartRads although it may be appropriate in some instances. Some heat pump controllers such as the WPM 2006/7 give an option to switch off the circulating pumps if the return temperature has been met for a set period of time. The system then assumes that no heating is required and therefore can switch off the circulating pumps. The controller will activate the pumps periodically to check the system temperature.

Whilst pump optimisation could reduce the running time of the pump, if there is a heating demand whilst the pump is turned off the SmartRad will be unable to communicate this demand and the room will not be heated.

7 Designing the system for Maximum Efficiency

7.1 Choosing a Mean Water Temperature (MWT)

The MWT is the average between the inlet and outlet across the radiator. Feedback from customers is that a MWT of 40°C gives adequate air off temperatures. Some customers have indicated that an air off temperature with a MWT of 35°C is acceptable if they understand the benefits of maximising heat pump COP.

7.1.1 Suggested MWT

Whilst there is no such thing as a typical installation, the following table suggests suitable flow temperature although the final choice is up to the installer.

System heater	Typical Mean Water temperature
Water, Air and Ground source heat pumps	Ideally low as possible. The lowest recommended temperature is 35°C with weather compensation fully activated and a design MWT of 40°C.
Condensing boilers	Below 55°C so that the flue gasses can condense all year round. As efficiency is not closely related to temperature it is best not to enable weather compensation since this will increase the SmartRad fan run time which has a small electrical consumption.
Systems with efficiency not affected by flow temperature.	The temperature does not matter so long as it falls within the product operating limits however care must be given to transmission losses between the radiators.

Table 1: Summary of suggested MWT temperatures

7.1.2 Air off temperatures

Decreasing the MWT will also decrease the air off temperature. A situation may be reached, particularly when there is a small heating demand where the air off temperatures are relatively low but the room is still being effectively heated. This phenomenon will be more pronounced because the moving air feels cooler than it actually is. The customer must be informed that the product operates at low air off temperatures in order to maximise the Heat pump efficiency. If the customer complains of cool air off temperatures from the product the MWT must be raised which will have a knock-on effect on the COP.

7.2 Weather compensation

A weather compensation function on a heat pump or boiler decreases the mean temperature of the heating system as the external temperature increases. Weather compensation will maximise the Heat Pump COP by ensuring that the MWT is only as high as it needs to be to meet the heating

demand. Care should be taken when setting the weather compensation curves that the Mean Water temperature does not fall too low, so that the air off temperatures starts to feel cool.

For a heat pump a lower mean system temperature gives a higher Coefficient of Performance. However, a lower mean system temperature reduces the output of the SmartRad, meaning that the fan has to be run on a higher setting. Computer modelling has shown that it is best to use weather compensation because the increased fan usage is far outweighed by the improvements in COP.