

AXMINSTER

**Trade**  
SERIES

Code 501215

# UB-801F Extractor



# **CONTENTS:**

IMPORTANT SAFETY RULES -----	<b>2</b>
SAFETY LABEL -----	<b>5</b>
GROUNDING INSTRUCTIONS -----	<b>7</b>
SPECIFICATIONS -----	<b>8</b>
CONTENTS OF PACKAGE & TRANSPORTATION-----	<b>9</b>
ASSEMBLY INSTRUCTION -----	<b>11</b>
WIRING DIAGRAM -----	<b>13</b>
OUTSIDE DIMENSION -----	<b>14</b>
EXPLODED DIAGRAM -----	<b>15</b>
PARTS LIST -----	<b>16</b>
MAINTENANCE / SERVICE -----	<b>17</b>

- **WARNING!**

Please read this manual carefully before assembly, testing and operating.

- **WARNING!**

Do not operate this unit until the hose is connected to the inlet port.

- **WARNING!**

This machine is for woodworking machinery use only, and prohibited for other purposes. The collection equipment (machine) is used for **dry** woodworking debris/chips/swarfs collection purpose. Any other application is prohibited. No explosive proof design is used.

# IMPORTANT SAFETY RULES

Wood working can be dangerous if safe and proper operating procedures are not followed. As with all machinery, there are certain hazards involved with the operation of the product. Using the machine with respect and caution will considerably lessen the possibility of personal injury. However, if normal safety precautions are overlooked or ignored, personal injury to the operator may result.

Safety equipment such as guards, push sticks, hold-downs, feather boards, goggles, dust masks and hearing protection can reduce your potential for injury. But even the best guard won't make up for poor judgment, carelessness or inattention. Always use common sense and exercise caution in the workshop. If a procedure feels dangerous, don't try it. Figure out an alternative procedure that feels safer. REMEMBER: Your personal safety is your responsibility.

## WARNING: FAILURE TO FOLLOW THESE RULES MAY RESULT IN SERIOUS PERSONAL INJURY

1. FOR YOUR OWN SAFETY, READ INSTRUCTION MANUAL BEFORE OPERATING THE TOOL. Learn the tool's application and limitations as well as the specific hazards peculiar to it.
2. KEEP GUARDS IN PLACE and in working order
3. ALWAYS WEAR EYE PROTECTION
4. GROUND ALL TOOLS. If tool is equipped with three-prong plug, it should be plugged into a three-hole electrical receptacle. If an adapter is used to accommodate a two-prong receptacle, the adapter plug must be attached to a known ground. Never remove the third prong.
5. REMOVE ADJUSTING KEYS AND WRENCHES. Form habit of checking to see that keys and adjusting wrenches are removed from tool before turning it "ON".
6. KEEP WORK AREA CLEAN. Cluttered areas and benches invite accidents.
7. DON'T USE IN DANGEROUS ENVIRONMENT. Don't use power tools in damp or wet locations, or expose them to rain. Keep work area well lighted.
8. KEEP CHILDREN AND VISITORS AWAY. All children and visitors should be kept a safe distance from work area.
9. MAKE WORKSHOP CHILDPROOF – with padlocks, master switches, or by removing starter keys.
10. DON'T FORCE TOOL. It will do the job better and be safer at the rate for which it was designed.
11. USE RIGHT TOOL. Don't force tool or attachment to do a job for which it was not designed.
12. WEAR PROPER APPAREL. No loose clothing, gloves, neck-ties, rings, bracelets, or other jewelry to get caught in moving parts. Non-slip footwear is recommended. Wear protective hair covering to contain long hair.
13. ALWAYS USE SAFETY GLASSES. Wear safety glasses. Everyday eyeglasses only have impact resistant lenses; they are not safety glasses. Also use face or dust mask if cutting operation is dusty.
14. SECURE WORK. Use clamps or a vise to hold work when practical. It's safer than using your hand and frees both hands to operate tool.
15. DON'T OVERREACH. Keep proper footing and balance at all times.
16. MAINTAIN TOOLS IN TOP CONDITION. Keep tools sharp and clean for best and safest performance. Follow instructions for lubricating and changing accessories.
17. DISCONNECT TOOLS before servicing and when changing accessories such as blades, bits, cutters, etc.
18. USE RECOMMENDED ACCESSORIES. The use of accessories and attachments not recommended by us may cause hazards or risk of injury to persons.
19. REDUCE THE RISK OF UNINTENTIONAL STARTING. Make sure switch is in "OFF" position before plugging in power cord.
20. NEVER STAND ON TOOL. Serious injury could occur if the tool is tipped or if the cutting tool is accidentally contacted.
21. CHECK DAMAGED PARTS. Before further use of the tool, a guard or other part that is damaged should be carefully checked to ensure that it will operate properly and perform its intended function – check for alignment of moving parts, binding of moving parts, breakage of parts, mounting, and any other conditions that may affect its operation. A guard or other part that is damaged should be properly repaired or replaced.
22. DIRECTION OF FEED. Feed work into a blade or cutter against the direction of rotation of the blade or cutter only.
23. NEVER LEAVE TOOL RUNNING UNATTENDED. TURN POWER OFF. Don't leave tool until it comes to a complete stop.
24. DRUGS, ALCOHOL, MEDICATION. Do not operate tool while under the influence of drugs, alcohol or any medication.
25. MAKES SURE TOOL IS DISCONNECTED FROM POWER SUPPLY while motor is being mounted, connected or reconnected.
26. WARNING: The dust generated by certain woods and wood products can be injurious to your health. Always operate machinery in well ventilated areas and provide for proper dust removal. Use wood dust collection systems whenever possible.

## Safety Contents:

1. CAUTION: This appliance is not suitable for picking up hazardous dust.
2. CAUTION: This appliance is for dry use only and is not to be used or stored outdoors in wet conditions.
3. Regularly examine the supply cord for damage. If damaged, replace the cord specified, before further use.
4. Only replace the supply cord with the type specified In the Instructions.
5. Only use the socket outlet/or plug on the appliance for purposes specified in the instruction manual
6. If the supply cord is damaged, it must be replaced by the manufacturer, its service agent or similarly qualified persons in order to avoid a hazard.
7. The appliance is to disconnected from its power source during cleaning or maintenance and when replacing parts or converting the appliance to another function.
8. **WARNING:** This appliance contains wood debris/dust hazardous to health. Operating emptying and maintenance operations, including removal of the dust collecting means, must only be carried out by authorized personnel wearing suitable personal protection. Do not operate without a good personal respiration device wearing or without a good ventilation system acc. to national health code/regulation.
9. When carrying out service or repair operations, all contaminated items which cannot be satisfactorily cleaned, are to be disposed of; such items shall be disposed of in impervious bags in accordance with any current regulation for the disposal of such waste.
10. It is necessary to provide for an adequate air change rate  $\angle$  in the room if the exhaust air is returned to the room. Reference to National Regulations is necessary.

# IMPORTANT SAFETY RULES FOR DUST COLLECTORS

**WARNING:** Basic precautions should always be followed when using your dust collector. To reduce the risk of injury, electrical shock or fire, comply with the safety rules listed below:

1. READ and understand the instruction manual before operating the dust collector.
2. DO NOT leave the dust collector plugged into the electrical outlet. Unplug dust collector from outlet when not in use and before servicing, changing bags, unclogging and cleaning.
3. ALWAYS turn the power switch "OFF" before unplugging the dust collector.
4. WARNING: TO REDUCE THE RISK OF ELECTRICAL SHOCK do not use outdoors or on wet surfaces. Use for dry pickup only!
5. FOLLOW all electrical and safety codes, including the National Electric Code (NEC) and the Occupational Safety and Health Regulations (OSHA). All electrical connections and wiring should be made by qualified personnel only.
6. DO NOT use the dust collector to pick up flammable or combustible liquids, such as gasoline. NEVER use the dust collector near any flammable or combustible liquids.
7. USE the dust collector to pick up wood materials only. DO NOT use the dust collector to pick up metal shavings, dust, water, or parts.
8. NEVER use the dust collector to dissipate fumes or smoke. NEVER pick-up anything that is burning or smoking, such as cigarettes, matches or hot ashes.
9. USE only as described in this manual.
10. DO NOT pull the dust collector by the power cord. NEVER allow the power cord to come in contact with sharp edges, hot surfaces, oil or grease.
11. DO NOT unplug the dust collector by pulling on the power cord. ALWAYS grasp the plug, not the cord.
12. DO NOT handle the plug or dust collector with wet hands.
13. REPLACE a damaged cord immediately. DO NOT use a damaged cord or plug. If the dust collector is not operating properly, or has been damaged, left outdoors or has been in contact with water, return it to an Authorized Service Center for service.
14. DO NOT use the dust collector as a toy. DO NOT use near or around children.
15. DO NOT insert fingers or foreign objects into the dust intake ports. Keep hair, loose clothing, fingers, and all body parts away from openings and moving parts of the dust collector.
16. DO NOT use the dust collector without a filter bag and dust collection bag in place and properly secured.
17. DO NOT operate the dust collector with unused dust intake ports uncapped. ALWAYS cover exposed dust intake ports.
18. PERIODICALLY INSPECT dust and filter bags for any cuts, rips or tears. NEVER operate the dust collector with a damaged bag or vacuum hose.
19. The dust collector is designed for home use or light commercial duty ONLY!
20. CONNECT dust collector to a properly grounded outlet only. See Grounding Instructions.
21. The residual current device (RCD) is used in the power supply system to reinforce the safety.

## MAINTENANCE:

1. **Please unplug the plug and turn off the power supply before doing maintenance & change the filters/filter bags & cleaning & repair.**
2. Please clean the filters/filter bags after daily work and also maintain the appliance in a period of time.

## **SAVE THESE INSTRUCTIONS**

# **GROUNDING INSTRUCTIONS**

The appliance must be grounded; if it should malfunction or breakdown, grounding provides a path of least resistance for electric current to reduce the risk of electric shock. This appliance is equipped with a cord that has a equipment-ground conductor and grounding plug. The plug must be inserted into an appropriate outlet that is properly installed and grounded in accordance with all local codes and ordinances.

**WARNING** – Improper connection of the equipment-grounding conductor can result in a risk of electric shock. Check with a qualified electrician or service person if you are in doubt as to whether the outlet is properly grounded. Do not modify the plug provided with the appliance – if it will not fit the outlet; have a proper outlet installed by a qualified electrician.

## **For grounded, cord-connected appliances:**

This appliance is for use on a circuit having a normal rating more than 120 volts and is factory-equipped with a specific electrical cord and plug to permit connection to a proper electrical circuit. Make sure that the appliance is connected to an outlet having the same configuration as the plug. No adaptor should be used with this appliance. If the appliance must be reconnected for use on a different type of electrical circuit, qualified service personnel should make the reconnection.

## **For a permanently connected appliance:**

This appliance must be connected to a grounded metal, permanent wiring system, or an equipment-grounding conductor must be run with the circuit conductors and connected to the equipment grounding terminal or lead on the appliance.

## **Operation Conditions:**

**Voltage** Steady state voltage: 0,9 to 1,1 of nominal voltage.

**Frequency** 0,99 to 1,01 of nominal frequency continuously; 0,98 to 1,02 short time.

**Harmonics** Harmonic distortion not exceeding 10% of the total r.m.s. voltage between live conductors for the sum of the 2<sup>nd</sup> through to the 5<sup>th</sup> harmonic.

**Voltage interruption** Supply interrupted or at zero voltage for not more than 3 ms at any random time in the supply cycle with more than 1 s between successive interruption.

**Voltage dips** Voltage dips not exceeding 20% of the peak voltage of the supply for more than one cycle with more than 1 s between successive dips.

The minimum requirement for all electrical equipment is correct operation between air temperature of +5°C and +45°C.

Electrical equipment is capable of operating correctly when the relative humidity does not exceeding 50% at a maximum temperature of +45°C.

Electrical equipment is capable of operating correctly at altitude up to 1000 m.

Electrical equipment is designed to withstand to protected against the effects of transportation, and storage temperature within a range of -25°C to +55°C and for short periods not exceeding 24h at up to +70°C.

Avoid exposing to vibration environment.

Avoid exposing to direct sunlight or heat rays.

Have to connect to the factory grounding system correctly away from electric magnetic interference source sites, such welding, discharge machine.

## **Specifications:**

**Motor-----1HP/1 Phase**

**Motor Speed----- 2850 RPM**

**Suction Capacity----- 700 CFM**

**Static Pressure----- 5.4 Inch H<sub>2</sub>O**

**Impeller Size----- 10"**

**Inlet Size----- 4"**

**Switch----- ON/OFF Switch**

**Overall Dimensions of Base----- 700 x 380 x 1450 mm**

**N.W. ----- 30 KGS**

**G.W. ----- 33 KGS**

**CUFT----- 7.6'**

### **Noise:**

Average A weighted sound pressure level of UB-801F: 78.5 dB (A)

Associated uncertainty K = 4 dB

Measured made in accordance with EN ISO 3746

**UNPACKING & CHECKING CONTENTS:**

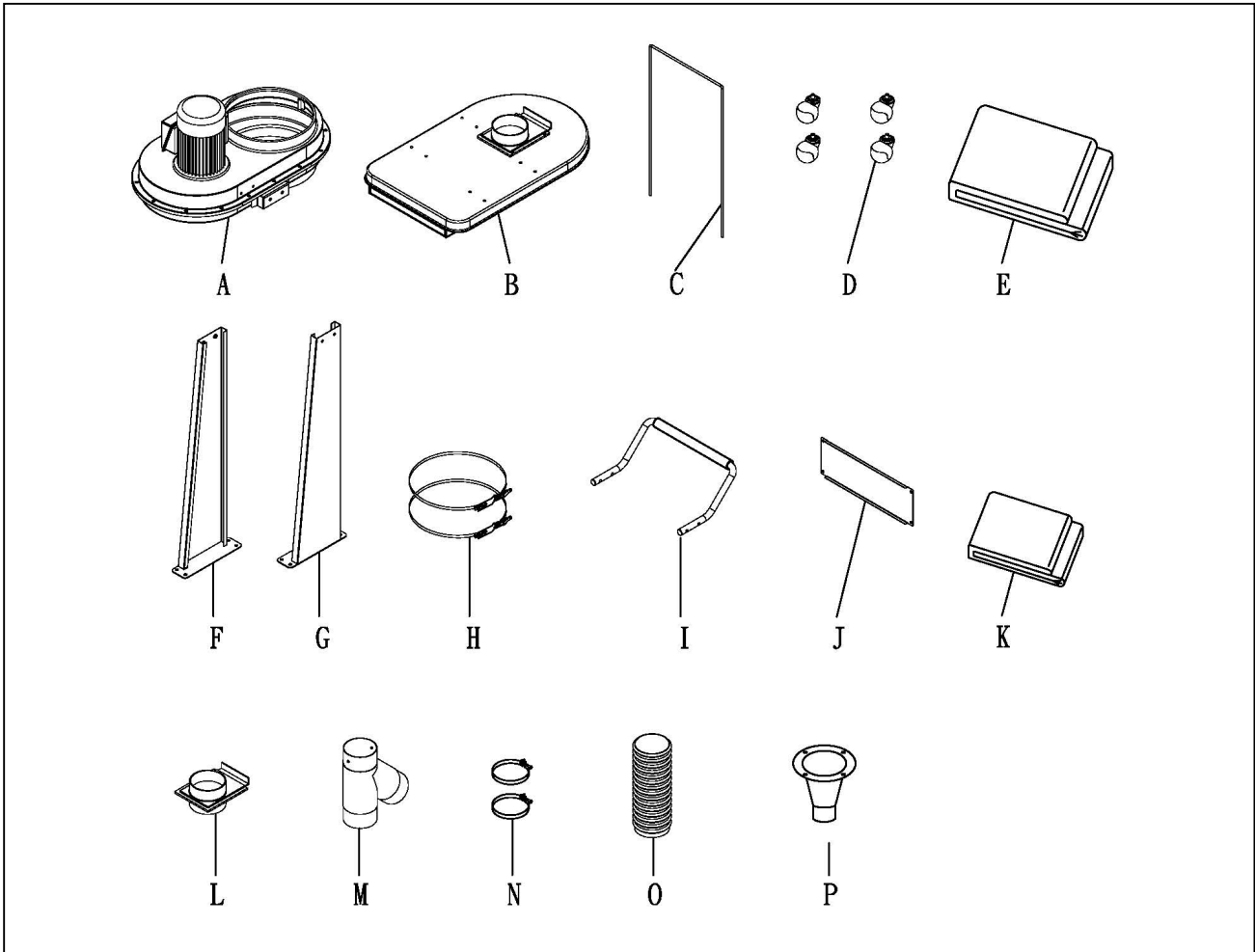

<b>NO.</b>	<b>Description</b>	<b>Specification</b>	<b>Q'TY</b>	<b>Part List No.</b>
<b>A</b>	<b>Housing</b>		<b>1</b>	<b>NO.3</b>
<b>B</b>	<b>Base</b>		<b>1</b>	<b>NO.19</b>
<b>C</b>	<b>Hanger</b>		<b>1</b>	<b>NO.30</b>
<b>D</b>	<b>Wheel</b>		<b>4</b>	<b>NO.22</b>
<b>E</b>	<b>Upper Bag</b>		<b>1</b>	<b>NO.1</b>
<b>F</b>	<b>Right Stand</b>		<b>1</b>	<b>NO.15</b>
<b>G</b>	<b>Left Stand</b>		<b>1</b>	<b>NO.14</b>
<b>H</b>	<b>Bag Clamp</b>		<b>2</b>	<b>NO.2</b>
<b>I</b>	<b>Handle</b>		<b>1</b>	<b>NO.8</b>
<b>J</b>	<b>Fixing Plate</b>		<b>1</b>	<b>NO.17</b>
<b>K</b>	<b>Polyester Bag</b>		<b>1</b>	<b>NO.16</b>
<b>L</b>	<b>Blast Gate</b>		<b>1</b>	<b>NO.36</b>
<b>M</b>	<b>Y-Inlet</b>	<b>4"</b>	<b>1</b>	<b>NO.32</b>
<b>N</b>	<b>Hose Clamp</b>	<b>4"</b>	<b>2</b>	<b>NO.35</b>
<b>O</b>	<b>Hose</b>	<b>4"</b>	<b>1</b>	<b>NO.37</b>
<b>P</b>	<b>Reducing Connector</b>		<b>1</b>	<b>NO.34</b>



## Hardware package:

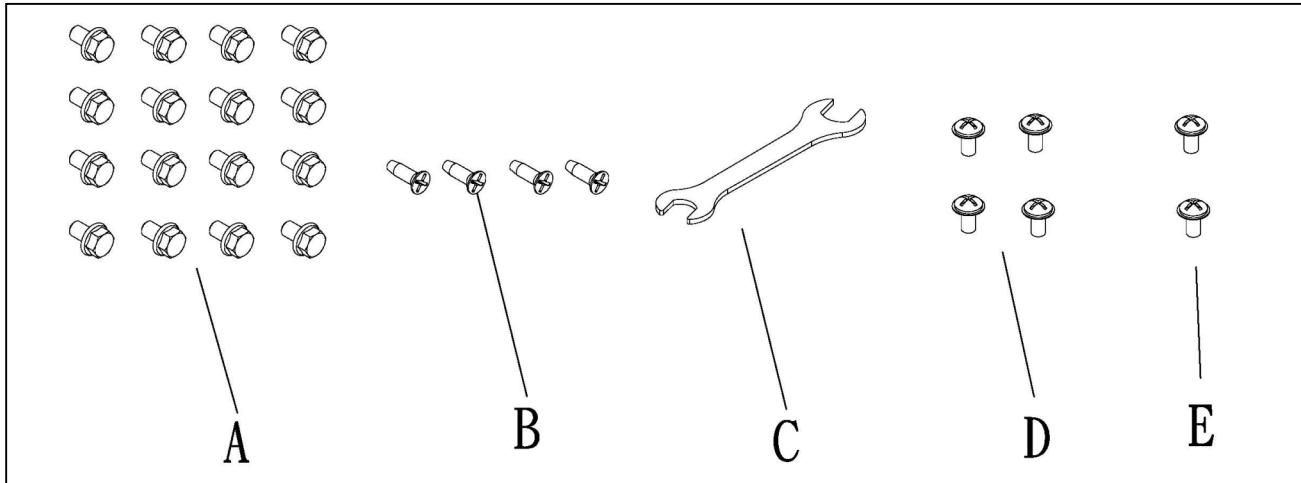

<b>NO.</b>	<b><u>Description</u></b>	<b><u>Specification</u></b>	<b>Q'TY</b>	<b>Part List No.</b>
<b>A</b>	<b>Flange Bolt</b>	<b>5/16"*1/2"</b>	<b>16</b>	<b>NO.13</b>
<b>B</b>	<b>Flat Head Screw</b>	<b>5/16"*1-1/4"</b>	<b>4</b>	<b>NO.7</b>
<b>C</b>	<b>Open Wrench</b>	<b>10*12</b>	<b>1</b>	<b>NO.31</b>
<b>D</b>	<b>Phillips Head Screw</b>	<b>3/16"*1/4"</b>	<b>4</b>	<b>NO.40</b>
<b>E</b>	<b>Phillips Head Screw</b>	<b>3/16"*3/8"</b>	<b>2</b>	<b>NO.33</b>

## TRANSPORTATION:

**Please have at least 2 people work together when lifting up!!!**

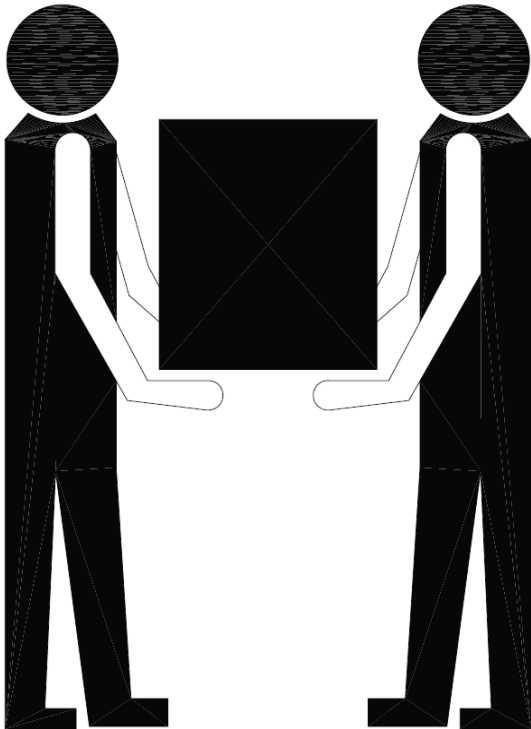

# ASSEMBLY INSTRUCTION

## STEP1.

Insert the wheels (NO.22) under the base (No.19) and tight with open wrench. (See FIG.1).

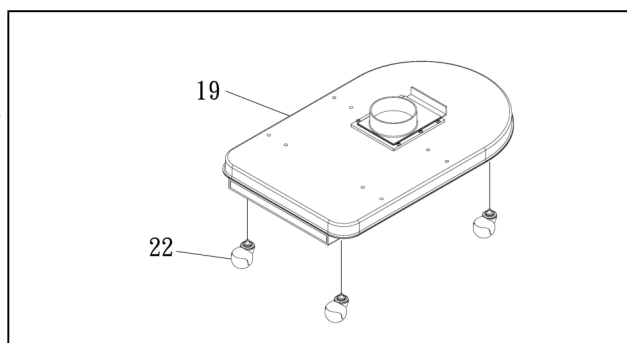

(FIG.1)

## STEP2.

Place the housing (NO.3) on the right stand (NO.15) and left stand (NO.14) tight with flange bolts. (NO.13) (See FIG.2)

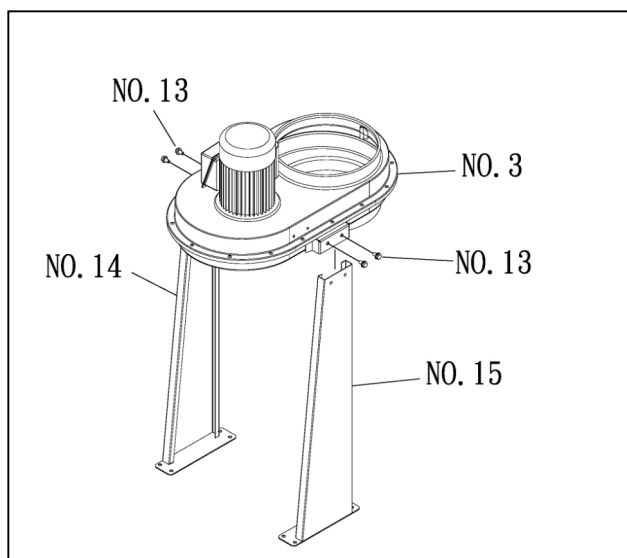

(FIG.2)

## STEP3-1.

Place the stand and housing set on the base tight with flange bolt. (NO.13) Next, tight the fixing plate (No.17) on the stands with flange bolts.

## STEP3-2.

Secure Reducing Connector(No.34) on Housing (No.3) with Phillips Head Screw (No.40) (See FIG.3)

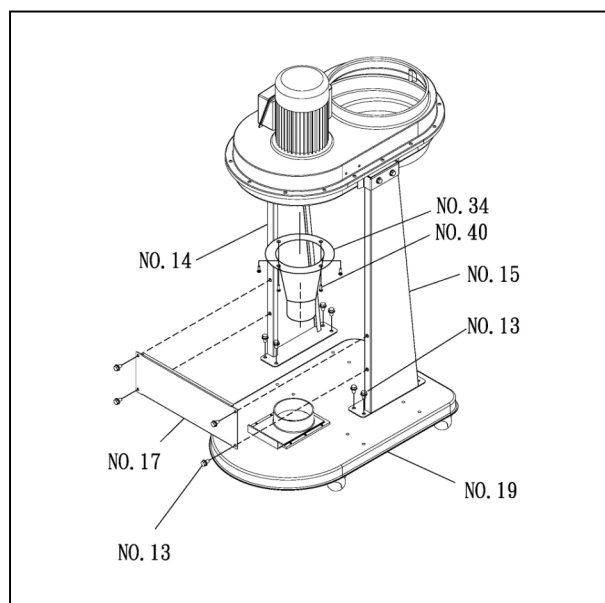

(FIG.3)

STEP4-1.

Place the handle (NO.8), on the top of the housing (NO.3) and tight with flat head screw. (NO.7)

STEP4-2.

Insert the hanger (NO.30) into the holes of the housing top. (See FIG.4)

STEP4-3

Attach Y Inlet (No.32) on Reducing Connector (No.34) and then use Hose (No.37) to connector Reducing Connector (No.34) and Blast Gate (No.38) also tight Hose (No.37) with Hose Clamp (No.35)

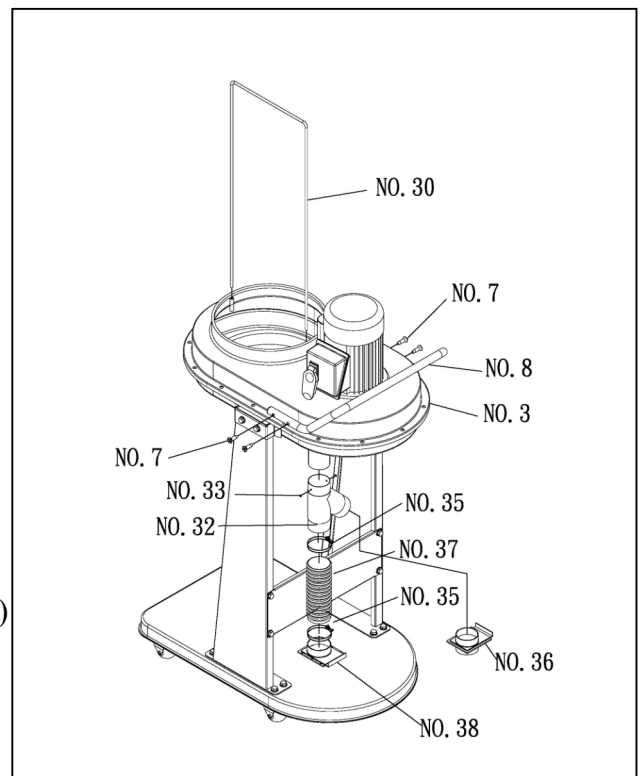

(FIG.4)

STEP5.

Place the upper bag (NO.1) and lower polyester bag (NO.16) on the top and bottom of the housing (NO.3), and tight with bag clamps. (NO.2) (See FIG 5)

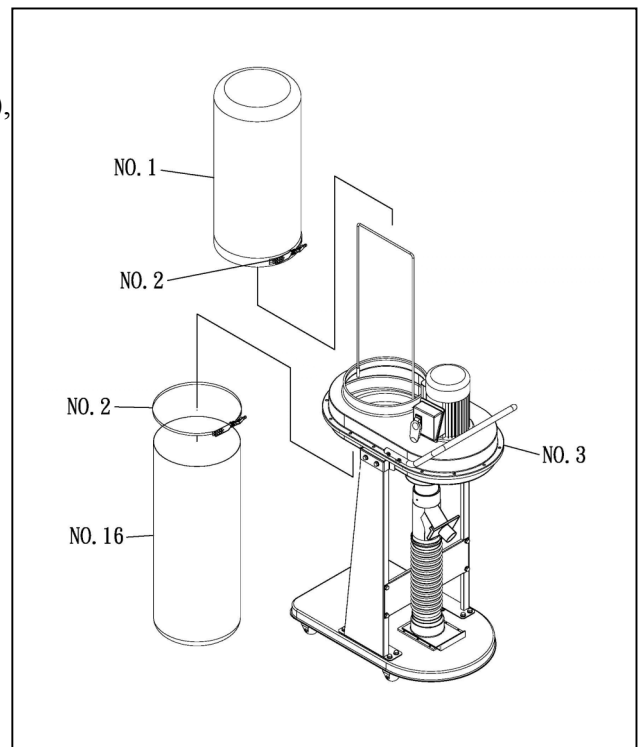

(Fig.5)

# OUTSIDE DIMENSION:

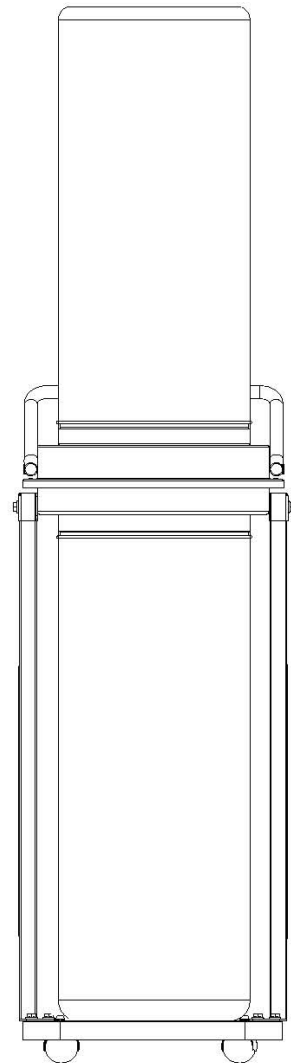
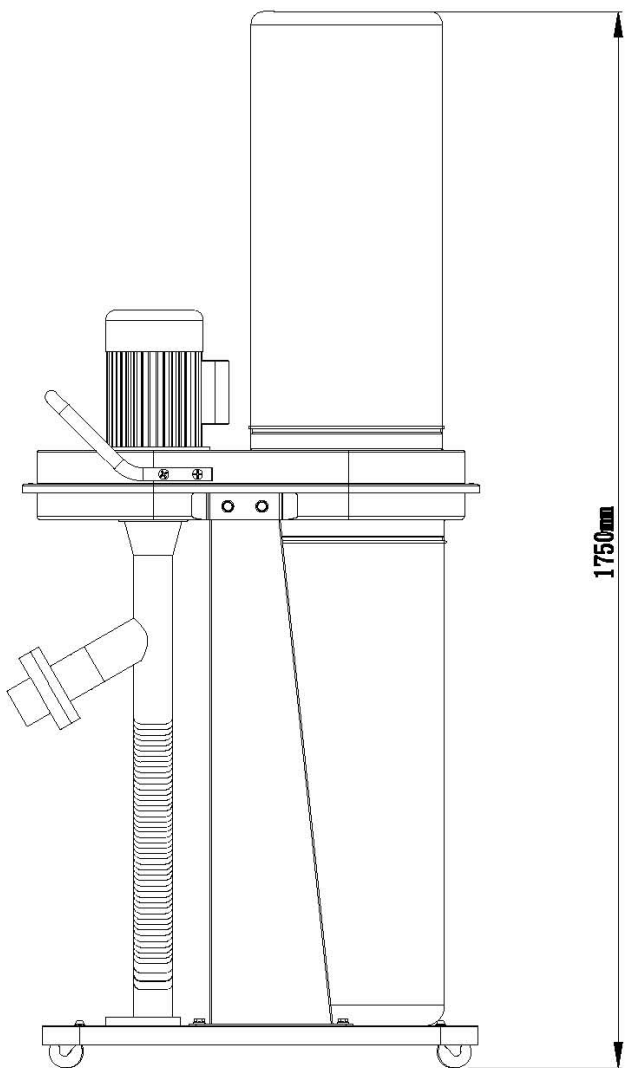
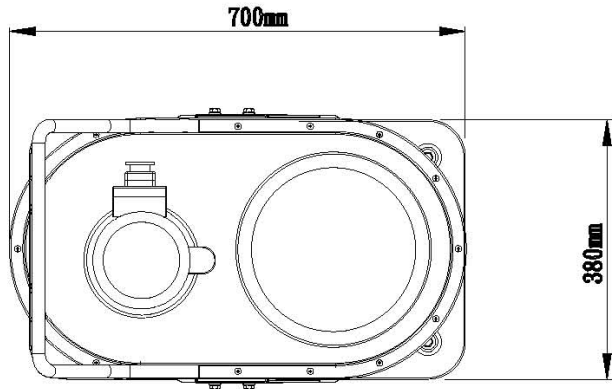

# EXPLODED DIAGRAM:

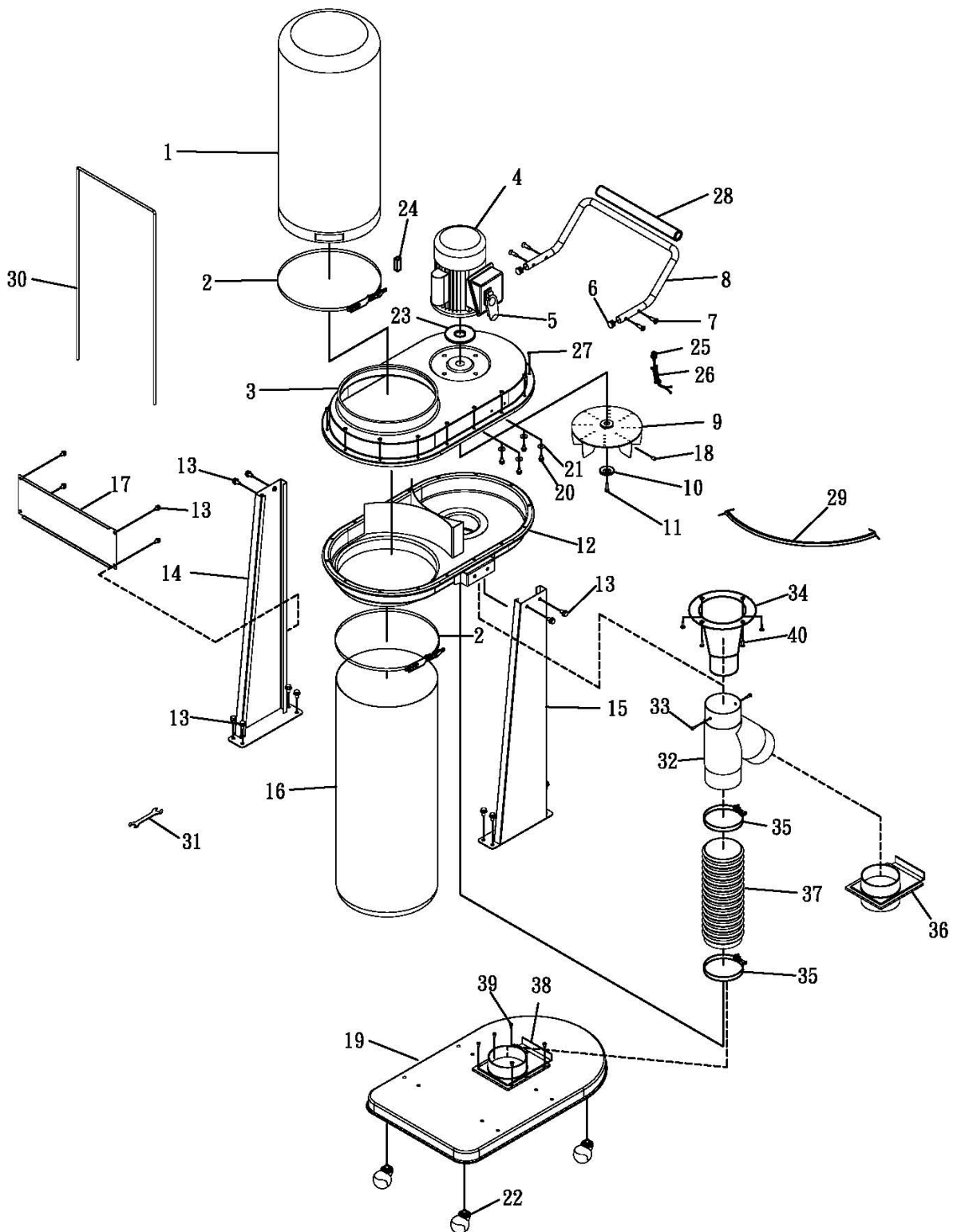

**Part List:**

<b>NO.</b>	<b>Description</b>	<b>Specification</b>	<b>Q'TY</b>
1	Upper Bag	Φ280*800	1
2	Bag Clamp	80H	1
3	Upper Housing		1
4	Motor	1HP	1
5	On/Off Switch		1
6	Cap	3/4"	2
7	Flat Head Screw	5/16"*1-1/4"	4
8	Handle		1
9	Impeller	10"	1
10	Impeller Washer		1
11	Cap Screw	M6*20	1
12	Lower Housing		1
13	Flange Bolt	5/16"*1/2"	16
14	Right Stand		1
15	Left Stand		1
16	Lower Plastic Bag	Φ280*800	1
17	Fixing Plate		1
18	Set Screw	5/16"*5/16"	1
19	Base		1
20	Flange Bolt	1/4"*1/2"	4
21	Washer	1/4*25mm	4
22	Ball Wheel	2"	4
23	Motor Packing		1
24	Key	5*5*25	1
25	Pushing		1
26	Power Cord		1
27	Tapping Screw	M5*10	16
28	Foam	7/8"*430*5	1
29	Housing Foam		1
30	Hanger		1
31	Open Wrench	10*12	1
32	Inlet	4"	1
33	Phillip Head Screw	3/16"x 3/8"	2
34	Reducing Connector		1
35	Cap	4"	1
36	Blast Gate	4"	1
37	Hose	4"	1
38	Blast Gate	4"	1
39	Phillip Head Screw	3/16"x 1/2"	6
40	Phillip Head Screw	3/16"x1/4"	4

# The **Axminster guarantee** is available on Hobby, Trade, Industrial, Engineer, Air Tools & Axcnc Technology Series machines

It's probably the most comprehensive FREE guarantee ever- buy with confidence from Axminster!  
So sure are we of the quality, we cover all parts and labour free of charge for three years!

- **Look for the icon and put your trust in Axminster**
- **No registration necessary - just keep your proof of purchase**
- **Optional Service Plan for Industrial Series machinery**



Great value & easy-to-use,  
perfect for use at home



Solid, reliable machines  
designed for daily use



Top performers with class leading features and  
build quality for use in busy workshops



Quality, precision machines  
for the workshop or education



Small machines for the home  
engineer



Compressors and tools for home or  
workshop use, durable and great value



Precision CNC machines for  
industry and education

Free Three Year Guarantee on Axminster Hobby, Trade and Industrial Series woodworking and engineering machines, Axminster Air compressors and Air Tools, and bench top grinders - no registration necessary just proof of purchase.

We will repair or replace at our discretion and will collect only from a UK mainland address, irrespective of the original delivery address

The Guarantee assumes that you have bought the correct machine for the required operation, in accordance with our guidelines; have operated and maintained it in accordance with the instruction manual; and that all cutting machines will be used with a blade which is sharp and serviceable at all times. It does not cover consumable items purchased with the original product, including original blades or abrasives

Normal wear and tear, misuse, abuse and neglect are excluded and the machine should not have been modified in any way. Please do not attempt to service the product without first contacting us; we are happy to guide you but failure to do so may invalidate the guarantee

The Guarantee is transferable from owner to owner in the first three years but you must have original proof of purchase. Should we need to replace a machine in the first three years the guarantee will still continue to be effective from the original purchase date

Full Terms and Conditions can be found here. This guarantee does not affect your statutory rights.

For more information visit [axminster.co.uk/3years](http://axminster.co.uk/3years)



Please dispose of packaging for the product in a responsible manner. It is suitable for recycling. Help to protect the environment, take the packaging to the local recycling centre and place into the appropriate recycling bin.

## Only for EU countries



Do not dispose of electric tools together with household waste material. In observance of European Directive 2002/96/EC on waste electrical and electronic equipment and its implementation in accordance with national law, electric tools that have reached the end of their life must be collected separately and returned to an environmentally compatible recycling facility.

Axminster Tool Centre,  
Unit 10 Weycroft Avenue, Axminster, Devon EX13 5PH

[axminster.co.uk](http://axminster.co.uk)