

x900 Series Switch and SwitchBlade® x908 Installation and Safety Guide



AT-8948
x900-48FE
x900-48FE-N
x900-48FS
AT-9924T
AT-9924SP
AT-9924Ts
x900-12XT/S
x900-24XT
x900-24XT-N
x900-24XS
SwitchBlade® x908

x900 Series Switch and SwitchBlade[®] x908 Installation and Safety Guide

AT-8948

x900-48FE

x900-48FE-N

x900-48FS

AT-9924T

AT-9924SP

AT-9924Ts

x900-12XT/S

x900-24XT

x900-24XT-N

x900-24XS

SwitchBlade[®] x908

Download the complete document set from
www.alliedtelesis.com/support/software

x900 Series Switch and SwitchBlade® x908 Installation and Safety Guide
Document Number C613-04052-00 REV J

© 2003-2007 Allied Telesis, Inc. All rights reserved. No part of this publication may be reproduced without prior written permission from Allied Telesis, Inc.

Allied Telesis, Inc. reserves the right to change specifications and other information in this document without prior written notice. The information provided herein is subject to change without notice. In no event shall Allied Telesis, Inc. be liable for any incidental, special, indirect, or consequential damages whatsoever, including but not limited to lost profits, arising out of or related to this manual or the information contained herein, even if Allied Telesis, Inc. has been advised of, known, or should have known, the possibility of such damages.

Allied Telesis, AlliedWare, AlliedWare Plus, and SwitchBlade are trademarks or registered trademarks in the United States and elsewhere of Allied Telesis, Inc. Adobe, Acrobat, and Reader are either registered trademarks or trademarks of Adobe Systems Incorporated in the United States and/or other countries. Microsoft and Visio are either registered trademarks or trademarks of Microsoft Corporation in the United States and/or other countries. Additional brands, names and products mentioned herein may be trademarks of their respective companies.

Contents

About this Guide	4
Package Contents	4
Selecting a Site	6
Installing the Switch	7
Applying Power to the Switch	11
Connecting to the Switch	13
Checking LEDs	19
Obtaining Documentation and Resources	23
Standards	25
Safety	26
Sicherheit	28
Sikkerhed	30
Veiligheid	32
Sécurité	34
Turvallisuus	36
Norme di Sicurezza	38
Sikkerhet	40
Segurança	42
Seguridad	44
Säkerhet	46
EC Declaration of Conformity	48

About this Guide

This Installation and Safety Guide describes how to install and log in to the following switches:

- AT-8948
- x900-48FE
- x900-48FE-N
- x900-48FS
- AT-9924T
- AT-9924SP
- x900-12XT/S
- AT-9924Ts
- x900-24XT
- x900-24XT-N
- x900-24XS
- SwitchBlade® x908

You can download the complete document set for x900 Series switches and SwitchBlade x908 from www.alliedtelesis.com/support/software. For more information about the document set and other resources, see “[Obtaining Documentation and Resources](#)” on page 23.

Package Contents

Depending on the model, the switch is factory-fitted with the following power supply and fan options:

- AT-8948, AT-9924Ts, x900-24XT, x900-24XT-N, and x900-24XS switches have a PSU and a FOM installed.
- AT-9924T, AT-9924SP, x900-48FE, x900-48FE-N, and x900-48FS switches have a PSU and a blanking plate installed.
- x900-12XT/S has a fixed PSU installed.
- SwitchBlade x908 has dual chassis fan modules and blanking plates installed, but no PSUs. Power supplies must be ordered separately.

Power supply units (PSU) can be:

- AT-PWR01, either AC or DC
- AT-PWR02 AC
- AT-PWR05 AC

How to install a PSU or fan in the switch is described in the *Removable Power Supply and Fan Installation Guide*.

The following items are shipped with each switch. Contact your authorised distributor or reseller if any are damaged or missing.

All models ship with:

- one cable for connecting the switch to a terminal or PC
- two rack-mount brackets
- depending on the switch, an appropriate number of M4 screws for rack-mount brackets
- this Installation and Safety Guide
- one warranty card

All models except the SwitchBlade x908 also ship with:

- AC power cord(s) (AC models only)
- one power cord retaining kit (AC models only)
 - 1 retaining clip
 - 2 retaining plates
 - 2 screws
- depending on the switch, four or five rubber feet with screws for mounting the switch on a level surface

Some products also ship with a Documentation and Tools CD-ROM containing documentation and utilities. For more information, see [“Obtaining Documentation and Resources”](#) on page 23.

Selecting a Site

Before you install the switch, review the following considerations about its location.

- AT-8948, x900-48FE, x900-48FS, and AT-9900 switches require an ambient temperature from 0°C to 50°C (32°F to 122°F).
- AT-9924Ts, x900-12XT/S, x900-24XT, x900-24XT-N, x900-24XS, and SwitchBlade x908 switches require an ambient temperature from 0°C to 40°C (32°F to 104°F).
- There should be adequate airflow around the switch and its vents.
- The site should be dust-free and without moisture.
- Humidity can be from 5% to 80% non-condensing.
- You need a reliable and earthed (grounded) power supply source, preferably dedicated and filtered.
- Cabling must not be exposed to sources of electrical noise, such as radio transmitters, broadband amplifiers, power lines, electric motors, and fluorescent fixtures.
- Switch ports are suitable for intra-building connections, or where non-exposed cabling is required.
- Related network devices can be connected to the switch but cannot exceed maximum cable lengths specified in the Hardware Reference.
- You may need to remove cabinet doors from the equipment rack to accommodate cords and cables.
- Ensure easy access to the switch's power and cable connections.
- The SwitchBlade x908 should only be installed in locations where access to the system is controlled. The SwitchBlade x908 is not intended for home use. If installed in a school, it should only be installed in a location restricted to service personnel.

Installing the Switch

Ports on the switch are suitable only for connections within buildings (intra-building) and with cables unexposed to the outside.

You can install the switch on a level surface, such as a desktop or bench, or in a standard 19-inch rack. Some switches are heavier at the rear than at the front. Use the brackets supplied with the switch when rack-mounting because they are designed to fully support the weight.

Before you begin

- Read the safety information.

For your well-being and that of the equipment, read the safety information in this document. You can also download this document from www.alliedtelesis.com/support/software.

- Verify the package contents if you have not already done so.

See “[Package Contents](#)” on [page 4](#). If any items are damaged or missing, contact your authorised distributor or reseller.

- Gather necessary tools and equipment:

- Phillips #2 screwdriver to loosen the blanking plate, if any.
- Rack-mount screws and nuts, and a suitable screwdriver. The SwitchBlade x908 requires eight sets of screws and nuts. All other switches required four sets.
- For DC installations, you need an appropriate DC power source, DC supply cable, ring connectors, and a crimp tool for screw terminal style connectors or appropriate connectors for the PSU model.

- Prepare the cabinet in a suitable location

Follow guidelines described in “[Selecting a Site](#)” on [page 6](#) to choose an appropriate location and modify the rack as necessary.

- Because the switch is deep, we recommend two people mount the switch in the rack and tighten the screws.

Preparation for NEBS

For Network Equipment Building System (NEBS) installations of the x900-24XT-N, do the following to ensure rack-mounted installations are earthed:

- Remove non-conductive coatings, such as lacquer and enamel, from the rack rail where hardware will contact it. Remove coatings from unplated connectors, braided strap, and bus bars, and bring them to a bright finish. Coat them with an antioxidant before connecting them. During installation, thread-forming screws with star washers may be used for this purpose.

- All bare conductors must be coated with an appropriate antioxidant compound before making crimp connections.



Warning Both AC and DC versions of this equipment must be earthed through the power cables provided.

On a level surface

1. Ensure the area has sufficient space for the switch and its cables.
If you have not already done so, review considerations in [“Selecting a Site” on page 6](#).

2. Unpack the switch.

3. Fit rubber feet, if supplied.

All models except the SwitchBlade x908 ship with rubber feet. They stop the switch from slipping and protect the surface from scratches. The x900-12XT/S switch has four feet. All other models have five feet. Using the screws provided, screw the rubber feet in the holes on the underside of the switch. Use the following diagram to locate the screw holes. For the x900-12XT/S, use positions 1, 2, 3, and 5.

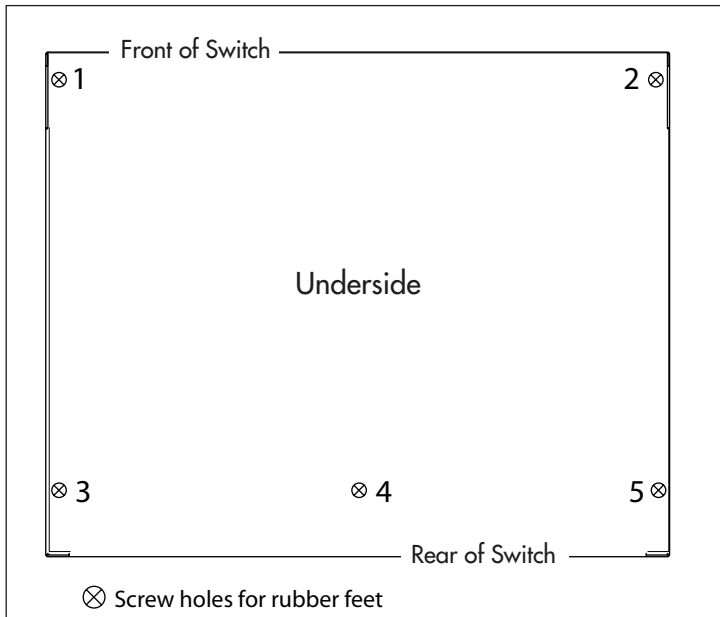

4. Place the switch in the desired location for operation.

In a 19-inch rack

1. Ensure the rack has sufficient space for the switch and its cables. For the switch's requirements, see [“Selecting a Site” on page 6](#).
2. Install cage nuts at the front of the rack so they are ready for the rack-mount screws in the following steps.
3. Unpack the switch.

It may be helpful to temporarily remove any PSU or FOM so that the switch is lighter and easier to manipulate during installation. For more information, see the *Removable Power Supply and Fan Installation Guide*.

4. Screw one bracket to each side of the switch using the M4 screws provided.
For NEBS ensure the rack and hardware have been pre-treated, as described in [“Preparation for NEBS” on page 7](#).

Fitting a bracket on a switch (except x900-12XT/S and SwitchBlade x908)

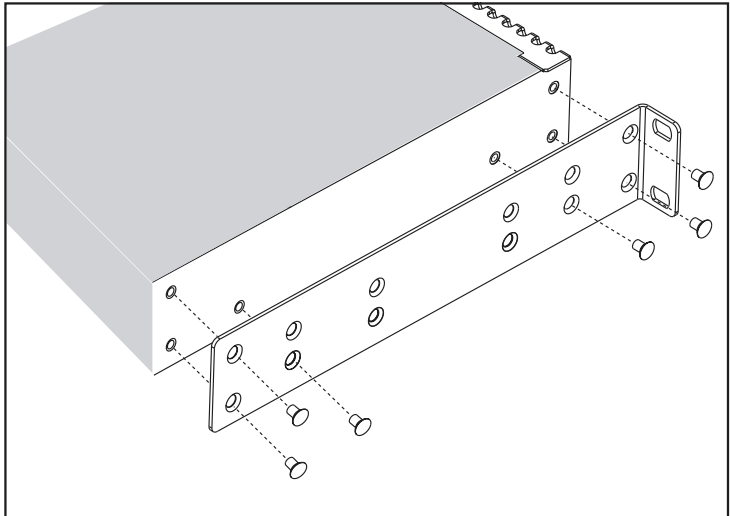

Fitting a bracket on an x900-12XT/S switch

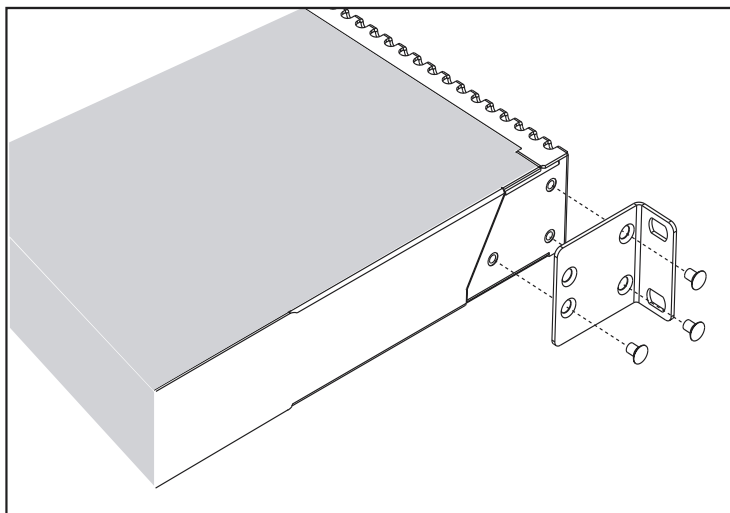

The SwitchBlade x908 has similar short brackets.

5. Mount the switch into the rack from the front, and tighten the rack-mount screws.

Two people are required at this point. One person can lift the switch into the rack and attach it to the front rails while the second person safely supports it from the rear.

Applying Power to the Switch

Power supply bays are in the rear of the switch. Depending on the model, the switch may have a PSU, FOM, or blanking plate over a power supply bay.

Connecting an AC power supply

Follow these instructions to connect one of the following to an AC power supply:

- an AT-PWR01, AT-PWR02, or AT-PWR05 AC PSU
- an x900-12XT/S switch



Warning The AT-PWR01 AC PSU has a fuse rating of 250V, 5A for FH101 and FH102.



Warning The AT-PWR01 AC PSU has double pole/neutral fusing. Electric shock is possible since there are dual primary fuses, one on the phase circuit and one on the neutral circuit. If the neutral opens, the phase may still be live.



Warning For SwitchBlade x908 AC models the grounding stud on the rear of the unit is for supplemental grounding only. The system must be supplied by a grounded 3 wire AC source through the power supply cord.

1. Plug the AC power cord that is provided into the power inlet on the PSU.
2. Connect the power cord to the main power source.
3. On the AT-PWR05, set the Run/Standby switch to Run.
4. Check that the PSU LED on the front panel of the switch is lit green. If the LED does not light, refer to the Hardware Reference for troubleshooting information.

Connecting a DC power supply

Follow these instructions to connect an AT-PWR01-80 DC PSU to a DC power supply. Only trained and qualified personnel should connect a DC power supply.

For centralised DC power connection, the switch should be installed in **restricted access areas only**, such as dedicated equipment rooms or equipment closets, in accordance with Articles 110-16, 110-17, and 110-18 of the National Electrical Code, ANSI/NFPA 70.

Power supply specifications:

- 40 to 60V, 48V nominal
- supports either positive grounded or negative grounded operation
- a 15Amp certified/listed circuit breaker is required for circuit protection

Supply cable specifications:

- three-core cable is required
- minimum core size: 3.3 mm² (12 AWG) high strand count copper wire
- minimum cable rating: 600 V, 90 degrees C



Warning Disconnect the power supply cable before starting this procedure.

1. Remove the transparent protective terminal cover.
2. Strip the supply cable wires to expose 7.5 mm (0.31 in.) of bare conductor. Terminate the wire with a nylon insulated solderless ring tongue terminal, JST FN5.5-5 or equivalent, using a crimp tool.
3. Connect the ground wire to the ground terminal. Use the diagram on the rear panel of the switch to identify terminals. Tighten the terminal to between 2.4 and 4.0 Nm (21.3 and 35.4 lbf in).



Caution Check that the PSU terminals are wired to the correct polarity. You will damage it if you incorrectly connect it.

4. Connect the positive feed to the + (positive) terminal and the negative feed to the - (negative) terminal. Tighten the terminals to between 2.4 and 4.0 Nm (21.3 and 35.4 lbf in).

Note that the DC return input terminal must be connected as an Isolated DC return (DC-I).

5. Ensure there are no exposed cable strands.



6. Replace the cover. You **must** replace the transparent plastic terminal cover before continuing.
7. Secure the supply cable to the rack framework or a similar object to ensure that connections are isolated from any force applied to the cable.
8. Ensure the circuit breaker is **off** for the supply circuit and the Run/Standby control on the PSU. Release the Run/Standby control so that it is not pushed in (which is the Off position).
9. Connect the supply cable wires to the circuit breaker.
10. Turn on the PSU by pushing in the Run/Standby control.
11. Confirm that the switch is receiving power.

Check that at least one of the PSU LEDs on the front panel of the switch is lit green. If no LEDs light, refer to the Hardware Reference for troubleshooting information.

Connecting to the Switch

All x900 Series switches and the SwitchBlade x908 can be configured using the Command Line Interface (CLI). The procedure and command syntax varies depending on whether the switch is running the AlliedWare® operating system or the AlliedWare Plus™ operating system.

AT-9900 Series switches running the AlliedWare operating system can also be configured using the Graphical User Interface (GUI).

Before configuring the switch, you must make some basic connections explained in the following procedures:

- [“Using the AlliedWare Plus Operating System CLI” on page 13](#)
- [“Using the AlliedWare Operating System CLI” on page 16](#)
- [“Using the AlliedWare Operating System GUI” on page 18](#)

Before starting these procedures, ensure that the switch is connected to a power supply and receiving power.

Using the AlliedWare Plus Operating System CLI

Depending on the model, an ASYN0/CONSOLE and/or ETH0 port is on the front of the switch for installation and maintenance.

- I. **To use the ETH0 port**, physically connect it to the terminal or PC, and check that the port’s LEDs are lit. This means a link has been established between the port and the PC. For NEBS compatibility, the cable must be shielded and grounded at both ends, especially if permanently connected.

The default configuration contains the following commands:

```
interface eth0
    ip address 192.168.242.242/24
```

Set the PC to an IP address in the 192.168.242.0 subnet, and then establish a Telnet session to 192.168.242.242.

When x900-24XT, x900-24XT-N, x900-24XS, or SwitchBlade x908 switches are connected to form a virtual chassis stack (VCS), the ETH0 port has additional operational functions. See the Hardware Reference for more information.

2. To use the **ASYN0/CONSOLE port**, physically connect it to the terminal or PC with the RJ-45 DB9 cable that is supplied. For NEBS compatibility, the cable must be shielded and grounded at both ends, especially if permanently connected.

Set communication parameters on your terminal or terminal emulation program to the following:

- bit rate: **9600**
- data bits: **8**
- parity: **None**
- stop bits: **1**
- flow control: **None**

For information about terminal emulation, see *Using Windows Terminal and HyperTerminal* in the Hardware Reference.

3. Log in at the prompt.

If using the ASYN0/CONSOLE port, the login prompt is displayed after the switch has booted. If not, press the Enter key two or three times.

When the switch boots for the first time, it automatically creates an account with manager privileges. The login name for the account is *manager* and the password is *friend*.

At the login prompt, enter the login name and password as follows:

```
Login: manager
Password: friend
```

The switch's command prompt is displayed upon successful login.

4. Change the password.

A manager account with the default password is a serious security risk. Remember the new password because there is no way to retrieve it if you forget it.

To change the account password, use the following commands:

```
awplus>enable
awplus#configure terminal
awplus(config)#username manager password <password>
```

5. Configure the switch.

Refer to the *AlliedWare Plus™ Operating System Software Reference* for detailed information about configuring the software.

For online help, type ? after:

- the prompt, to list all commands available in the command mode you are in
- one or more parameters, to list parameters that can come next in the partial command
- one or more letters of a parameter, to list matching parameters

To complete a keywords, press the Tab key after part of the command. If only one keyword matches the partial command, the CLI fills in that keyword. If multiple keywords match, it lists them.

6. Save the configuration.

Save the current configuration as the default startup configuration `boot.cfg` by using the commands:

```
awplus>enable
awplus#copy running-config startup-config
```

Alternatively, you can save the current configuration with a different file name and then set the switch to load this file when it restarts by using the commands:

```
awplus>enable
awplus#copy running-config <filename>.cfg
awplus#configure terminal
awplus(config)#boot config-file <filename>.cfg
```

Using the AlliedWare Operating System CLI

Depending on the model, an ASYN0/CONSOLE and/or ETH0 port is on the front of the switch for installation and maintenance.

1. **To use the ETH0 port**, physically connect it to the terminal or PC, and check that the port's LEDs are lit. This means a link has been established between the port and the PC. For NEBS compatibility, the cable must be shielded and grounded at both ends, especially if permanently connected.

The default configuration contains the following commands:

```
enable ip
add ip int=eth0 ip=192.168.242.242
```

Set the PC to an IP address in the 192.168.242.0 subnet, and then establish a Telnet session to 192.168.242.242.

2. **To use the ASYN0/CONSOLE port**, physically connect it to the terminal or PC with the RJ-45 DB9 cable that is supplied. For NEBS compatibility, the cable must be shielded and grounded at both ends, especially if permanently connected.

Set communication parameters on your terminal or terminal emulation program to the following:

- bit rate: **9600**
- data bits: **8**
- parity: **None**
- stop bits: **1**
- flow control: **Hardware**

For information about terminal emulation, see *Using Windows Terminal and HyperTerminal* in the Hardware Reference.

3. Log in at the prompt.

If using the ASYN0/CONSOLE port, the login prompt is displayed after the switch has booted. If not, press the Enter key two or three times.

When the switch boots for the first time, it automatically creates an account with manager privileges. The login name for the account is *manager* and the password is *friend*.

At the login prompt, enter the login name and password as follows:

```
Login: manager
Password: friend
```

The switch's command prompt is displayed upon successful login.

4. Change the password.

A manager account with the default password is a serious security risk. Remember the new password because there is no way to retrieve it if you forget it.

To change the account password, use the **set password** command.

5. Configure online help.

To use online help you must first configure the help file by using one of these commands:

For AT-8948, x900-48FE, x900-48FE-N, x900-48FS, and AT-9900 switches, use:

```
set help=<filename>.hlp
```

For AT-9924Ts, x900-24XT, x900-24XT-N, and x900-24XS switches, use:

```
set install=preferred help=help-filename
```

Help files have an HLP extension. To see the help files on your switch, use the command:

```
show system
```

6. Configure the switch.

Refer to the *x900 Series Switch AlliedWare[®] Operating System Software Reference* for more information about configuring the software.

Alternatively, if you do not know the command syntax, use any of the following to help you:

- To display a list of help topics, use the **help** command.
- To display help on a specific topic, use the **help <topic>** command.
- To display a list of valid options, type a question mark or press the Tab key at the end of a partial command.
- To complete a parameter after you have typed enough letters to uniquely match the desired one, press the Tab key.

7. Save the configuration.

Save your configuration to a new file by using the command:

```
create config=<filename>.cfg
```

Then set the switch to load this file when it restarts by using the command:

```
set config=<filename>.cfg
```

Using the AlliedWare Operating System GUI

Follow this procedure to establish a connection to an AT-9900 series switch, so you can use the GUI to configure the switch.

1. Select a PC to use and identify its subnet.

You can browse to the switch from any PC running a supported operating system with a supported browser. See *Using the Graphical User Interface (GUI) on AT-9900 Series Switches* in the *AlliedWare® Operating System Software Reference* for a list of supported combinations. JavaScript must be enabled. While using the GUI, disable any toolbars or plug-ins on your browser that block pop-ups. The GUI displays detailed configuration options and information in pop-up windows.

2. Connect the PC to the switch.

Use an Ethernet cable to connect an Ethernet card on the PC to any of the switch ports. You can browse to the router through any VLAN as long as you give it an IP address. These instructions assume you are using vlan 1. All switch ports belong to vlan 1 by default.

3. Access the CLI from the PC as described in [“Using the AlliedWare Operating System CLI” on page 16](#).

4. Enable IP.

```
enable ip
```

5. Assign the vlan 1 interface an IP address in the same subnet as the PC.

```
add ip interface=vlan1 ip=ipaddress mask=mask  
enable http server
```

6. Save the configuration and set the switch to use it on bootup.

```
create config=your-name.cfg  
set config=your-name.cfg
```

7. On the PC's web browser, bypass the HTTP proxy server, if necessary.

8. Point your web browser at the IP address for vlan 1.

9. At the login prompt, enter the user name and password.

```
User Name: manager  
Password: friend
```

The System Status page is displayed. Select options from the sidebar menu to configure and manage the switch.

For context-sensitive online help, click the Help button at the top of the sidebar menu or on any pop-up page.

Checking LEDs

The following LEDs report operations and faults on x900 Series and SwitchBlade x908 switches:

- “System LEDs” on page 19
- “Stacking LEDs” on page 21
- “PWR01 LEDs” on page 21
- “PWR02 LEDs” on page 22
- “PWR05 LEDs” on page 22

LEDs for Ethernet ports and Small Form Factor Pluggable (SFP) ports are described in the Hardware Reference.

System LEDs The following table describes how LEDs on the switch report operations and faults.

LED	State	Description
PSU 1	Green	The PSU is installed and supplying power to the switch. The voltage output is within specification.
and PSU 2	Red	One of the following: <ul style="list-style-type: none"> • The PSU is installed in the switch, and a fan has failed or the PSU has exceeded its recommended temperature threshold. • A FOM is installed in the switch and a fan has failed. The x900-12XT/S and SwitchBlade x908 switches do not support FOMs. • The bay is empty. Applies to AT-8948, AT-9924Ts, x900-24XT, x900-24XT-N, and x900-24XS switches which require a FOM when only one PSU is installed. • Dual PSUs are installed, but the PSU is not receiving power.
	Off	A FOM is installed and operating at an acceptable speed. For AT-9924T, x900-48FE, x900-48FE-N, x900-48FS, and SwitchBlade x908 switches, a blanking plate is installed.
POWER	Green	The PSU is operating and supplying power to the switch. The voltage output is within specification. Valid for the x900-12XT/S switch.

LED	State	Description (cont)
POE PSU 1 and PSU 2	Green	The PSU is installed and supplying power. Voltage output, fan speed, and operating temperature are within specification. Valid for the SwitchBlade x908 switch.
	Red	The voltage output is not within specification, a fan has failed or the PSU has exceeded its recommended temperature threshold. Valid for the SwitchBlade x908 switch.
Fault	Red	The switch or management software is malfunctioning.
	Red flashing	The following flash sequences indicate a hardware-related fault. After sequences of two or more flashes, the LED stops briefly, then repeats the sequence. If multiple faults occur, the LED flashes each sequence in turn, stops briefly, then repeats the sequences.
	1 Flash	One or more heatsink fans has failed or is operating below the recommended speed.
	2 Flashes	For SwitchBlade x908 switches, one or both of the chassis fans are not installed, or the fans are operating below the recommended speed.
	3 Flashes	For AT-9924T, AT-9924SP, AT-9924Ts, x900-24XT, x900-24XT-N, and x900-24XS switches, the ability to monitor temperature and fans has failed, and it cannot report whether they are in the supported ranges.
	4 Flashes	For switches running the AlliedWare Plus operating system, a XEM failed to initialise or is incompatible.
	6 Flashes	The switch's temperature has exceeded the recommended threshold.
	Slow flashing at startup	The SDRAM (DIMM) has not been detected. Does not apply to AT-9924Ts, x900-12XT/S, x900-24XT, x900-24XT-N, x900-24XS, and SwitchBlade x908 switches.
Rapid flashing at startup	The SDRAM (DIMM) is not compatible with the switch. Does not apply to AT-9924Ts, x900-12XT/S, x900-24XT, x900-24XT-N, x900-24XS, and SwitchBlade x908 switches.	

LED	State	Description (cont)
CF	Green flashing	The CompactFlash memory card is active and should not be ejected. The card can be safely ejected when the LED remains off. Valid for AT-8948, x900-48FE, x900-48FE-N, x900-48FS, AT-9924T, and AT-9924SP switches.
SD	Green flashing	The Secure Digital memory card is active and should not be ejected. The card can be safely ejected when the LED remains off. Valid for AT-9924Ts, x900-12XT/S, x900-24XT, x900-24XT-N, x900-24XS, and SwitchBlade x908 switches.

Stacking LEDs The following table describes how LEDs on the SwitchBlade x908 report operations and faults on the rear panel stacking ports.

LED	State	Description
STATUS	Green	The switch is the stack master.
	Amber	The switch is a stack member.
	Green flashing	The switch is in the process of learning the stack topology and selecting the stack master.
	Off	The switch is not a stack member.
PORT 1 and PORT 2	Green	A link has been established.
	Amber flashing	The link has a transmission fault.

PWR01 LEDs The following table describes LEDs on the PWR01 power supply unit.

LED	State	Description
Fault	Red	The temperature on the PSU has exceeded the limit of 75° C (167° F), or the fan failed.
PWR	Green	A PSU is installed in the switch and is delivering power. A FOM does not have this LED.

PWR02 LEDs The following table describes LEDs on the PWR02 power supply unit.

LED	State	Description
Fault	Red	The temperature on the PSU has exceeded the limit of 75° C (167° F), or the fan failed.
PWR	Green	A PSU is installed in the switch and is delivering power. A FOM does not have this LED.

PWR05 LEDs The following table describes LEDs on the PWR05 (AC) power supply unit for the SwitchBlade x908.

LED	State	Description
~	Green	AC input voltage is within 90-264VAC, 47-63Hz.
	Off	AC input voltage is outside the acceptable range.
≡	Green	DC output voltage is within 12V +/- 10%.
	Off	DC output voltage is outside the acceptable range.
⏏	Red	A fault has occurred. There is either a fan failure, or the temperature has exceeded its limit of 70° C (158° F).
	Off	No fault conditions detected.

Obtaining Documentation and Resources

The complete document set for x900 Series switches and SwitchBlade x908 includes:

- this Installation and Safety Guide
- the *x900 Series Switch and SwitchBlade® x908 Hardware Reference*, which contains detailed information on x900 Series and SwitchBlade x908 switches and their hardware features
- the *Removable Power Supply and Fan Installation Guide*, which describes how to install power supply units and fan-only modules in x900 Series and SwitchBlade x908 switches
- the *x900 Series Switch and SwitchBlade® x908 Expansion Module Installation Guide*, which describes how to install expansion modules in x900 Series and SwitchBlade x908 switches
- the *AT-9900s Series Switch Expansion Module Installation Guide*, which describes how to install expansion modules in AT-9900s Series switches
- the *x900 Series Switch AlliedWare® Operating System Software Reference*, which contains detailed information on configuring switches running the AlliedWare operating system
- the *AlliedWare Plus™ Operating System Software Reference*, which contains detailed information on configuring switches running the AlliedWare Plus operating system

You can download these documents and updates from www.alliedtelesis.com/support/software.

You need Adobe® Acrobat® Reader® software to view, search, or print these documents. You can download it from www.adobe.com.

Other resources

How-To Notes describe a range of standard Allied Telesis solutions, and include technical tips and guides to configuring specific hardware and software features. You can download the latest How-To Notes from www.alliedtelesis.com/resources/literature/howto.aspx.

MIBs supported by Allied Telesis products can be downloaded from www.alliedtelesis.com/support/software.

Microsoft® Visio® stencils for Allied Telesis products can be downloaded from www.alliedtelesis.com/resources/images/visio.aspx.

AT-TFTP Server for Windows is a TFTP (*Trivial File Transfer Protocol*) server for transferring software versions, configuration scripts and other files between a PC and the switch. You download AT-TFTP Server from www.alliedtelesis.com/support/software.

CD-ROM

Some products ship with a Documentation and Tools CD-ROM, which includes:

- the complete document set
- Adobe® Acrobat® Reader®
- AT-TFTP Server
- Supported MIBs
- How-To Notes, white papers, Microsoft® Visio® stencils and other resources
- Tryouts of networking software

Contacting us

With locations covering all of the established markets in North America, Latin America, Europe, Asia, and the Pacific, Allied Telesis provides localized sales and technical support worldwide. To find the representative nearest you, visit us on the Web at www.alliedtelesis.com.

Standards

Where applicable, the products in this document meet the following standards:

Approval Agency and Requirement		
Safety	UL60950-1 CAN/CSA-C22.2 No. 60950-1-03 EN60950-1 AS/NZS 60950.1	EN 60825-1 EN 60825-2 21 CFR 1040
Electromagnetic	FCC CFR47 Part 15 Class A EN55022 Class A VCCI Class A AS/NZS CISPR22 Class A	CNS 13438 Class A EN61000-3-2/3 EN55024 ETSI 300 386
NEBS	GR-63-Core NEBS Level 3 GR-1089-Core NEBS Level 3	
ETSI	ETSI 300 019 ETSI 300 132	
WEEE	Meets requirements of Directive 2002/96/EC of the European Parliament and of the council of 27 January 2003	
RoHS	Meets requirement of Directive 2002/95/EC of the European Parliament and of the council of 27 January 2003	

U.S. Federal Communications Commission

RADIATED ENERGY

Note: This equipment has been tested and found to comply with the limits for a Class A digital device pursuant to Part 15 of the FCC Rules. These limits are designed to provide reasonable protection against harmful interference when the equipment is operated in a commercial environment. This equipment generates, uses, and can radiate radio frequency energy and, if not installed and used in accordance with this instruction manual, may cause harmful interference to radio communications. Operation of this equipment in a residential area is likely to cause harmful interference in which case the user will be required to correct the interference at his own expense.

Note: Modifications or changes not expressly approved by the manufacturer or the FCC can void your right to operate this equipment.

Canadian Department of Communications

This Class A digital apparatus meets all requirements of the Canadian Interference-Causing Equipment Regulations.

Cet appareil numérique de la classe A respecte toutes les exigences du Règlement sur le matériel brouilleur du Canada.

この装置は、クラスA情報技術装置です。この装置を家庭環境で使用すると電波妨害を引き起こすことがあります。この場合には使用者が適切な対策を講ずるよう要求されることがあります。

VCCI- A

警告使用者：

這是甲類的資訊產品，在居住的環境中使用時，可能會造成射頻干擾，在這種情況下，使用者會被要求採取某些適當的對策。

BSMI- A

Safety



WARNING: In a domestic environment this product may cause radio interference in which case the user may be required to take adequate measures.



WARNING: Class I Laser product.



WARNING: Do not stare into the laser beam.



CAUTION: Use of controls or adjustments of performance or procedures other than those specified herein may result in hazardous radiation exposure.



ELECTRICAL NOTICES

WARNING: ELECTRIC SHOCK HAZARD

To prevent ELECTRIC shock, do not remove the cover. No user-serviceable parts inside. This unit contains HAZARDOUS VOLTAGES and should be opened only by a trained and qualified technician.



LIGHTNING DANGER

DANGER: DO NOT WORK on equipment or CABLES during periods of LIGHTNING ACTIVITY.



CAUTION: POWER CORD IS USED AS A DISCONNECTION DEVICE. TO DE-ENERGIZE EQUIPMENT, disconnect the power cord.



ELECTRICAL - TYPE CLASS I EQUIPMENT

THIS EQUIPMENT MUST BE EARTHED. Power plug must be connected to a properly wired earth ground socket outlet. An improperly wired socket outlet could place hazardous voltages on accessible metal parts.



PLUGGABLE EQUIPMENT, the socket outlet shall be installed near the equipment and shall be easily accessible.



CAUTION: Air vents must not be blocked and must have free access to the room ambient air for cooling.



OPERATING TEMPERATURE: The AT-8948, x900-48FE, x900-48FE-N, x900-48FS, and AT-9900 series switches are designed for a maximum ambient temperature of 50 degrees C. The AT-9924Ts, x900-12XT/S, x900-24XT, x900-24XT-N, x900-24XS, and SwitchBlade x908 switches are designed for a maximum of 40 degrees C. Derate the x900-24XT, x900-24XT-N, x900-24XS, and SwitchBlade x908 switches by 1 degree C per 305 Meters (1000ft).



ELECTRICAL - AC MAINS CIRCUIT OVERLOADING

When installing product, consideration must be given to the accumulative nameplate ratings when connecting the equipment to the AC supply wiring.



CAUTION: MECHANICAL LOADING - Mounting of the equipment in the rack should be such that a hazardous condition is not achieved due to uneven loading.



Lithium Battery - Should be changed only by authorised service personnel.

CAUTION: Danger of explosion if battery is incorrectly replaced. Replace only with Lithium Battery, type CR2032, and dispose of in accordance with the manufacturer's recommendations and all local codes.



ALL COUNTRIES: Install product in accordance with local and National Electrical Codes.



WARNING: For centralized DC power connection, install only in a restricted access area.



A tray cable is required to connect the power source if the unit is powered by centralized DC power. The tray cable must be UL listed Type TC tray cable and rated at 600 V and 90 degrees C, with three conductors, minimum 12 AWG.



WARNING: Only trained and qualified personnel are allowed to install or replace this equipment.



WARNING: As a safety precaution, a 15 Amp circuit breaker should be installed at the supply end of the cable to be used with this LAN equipment.

Always connect the wiring to the LAN equipment first before connecting the wiring to the breaker. To avoid the danger of physical injury from electrical shock, do not work with HOT feeds. Always be sure that the breaker is in the Off position before connecting the wiring to the breaker.



WARNING: Do not strip more than the recommended amount of wire. Stripping more than the recommended amount can create a safety hazard by leaving exposed wire on the terminal block after installation.



WARNING: When installing this equipment, always ensure that the frame ground connection is installed first and disconnected last.



WARNING: "Safety Hazard" - Check to see if there are any exposed copper strands coming from the installed wires. When this installation is done correctly, there should be no exposed copper wire strands extending from the terminal block. Any exposed wiring can conduct harmful levels of electricity to persons touching the wires.



DC versions of this system will work with a positive grounded or negative grounded DC system.

Sicherheit



WARNUNG: Bei Verwendung zu Hause kann dieses Produkt Funkstörungen hervorrufen. In diesem Fall müßte der Anwender angemessene Gegenmaßnahmen ergreifen.



WARNUNG Laserprodukt der Klasse I.



WARNUNG Nicht direkt in den Strahl blicken.



ACHTUNG: GEFÄHRLICHE SPANNUNG

Das Gehäuse nicht öffnen. Das Gerät enthält keine vom Benutzer wartbaren Teile. Das Gerät steht unter Hochspannung und darf nur von qualifiziertem technischem Personal geöffnet werden.



GEFAHR DURCH BLITZSCHLAG

GEFAHR: Keine Arbeiten am Gerät oder an den Kabeln während eines Gewitters ausführen.



VORSICHT: DAS NETZKABEL DIENT ZUM TRENNEN DER STROMVERSORGUNG. ZUR TRENNUNG VOM NETZ, KABEL AUS DER STECKDOSE ZIEHEN.



GERÄTE DER KLASSE I

DIESE GERÄTE MÜSSEN GEERDET SEIN. Der Netzstecker darf nur mit einer vorschriftsmäßig geerdeten Steckdose verbunden werden. Ein unvorschriftsmäßiger Anschluß kann die Metallteile des Gehäuses unter gefährliche elektrische Spannungen setzen.



STECKBARES GERÄT: Die Anschlußbuchse sollte in der Nähe der Einrichtung angebracht werden und leicht zugänglich sein."



VORSICHT

Die Entlüftungsöffnungen dürfen nicht versperrt sein und müssen zum Kühlen freien Zugang zur Raumluft haben.



BETRIEBSTEMPERATUR: AT-8948, x900-48FE, x900-48FE-N, x900-48FS, AT-9900 series produkt wurde für den Betrieb in einer Umgebungstemperatur von nicht mehr als 50 grad C entworfen. Die AT-9924Ts, x900-12XT/S, x900-24XT, x900-24XT-N, x900-24XS, SwitchBlade x908 produkt wurde für den Betrieb in einer Umgebungstemperatur von nicht mehr als 40 grad C entworfen.



NETZSICHERUNG

Bei der Installation muß der auf dem Typenschild angezeigte Nennwert des Gerätes für den Anschluß an das Netz beachtet werden.



VORSICHT: RAHMENEINBAU

Die Geräte müssen so in den Rahmen montiert werden, daß keine Gefahren durch unebenen inbau des Rahmens verursacht werden.



Lithium-Batterie - Sollte nur von einem geschulten qualifizierten Techniker ausgetauscht werden.

VORSICHT: Explosionsgefahr bei unsachgemäßem Austausch der Batterie. Nur mit einer gleichen Batterie oder einem gleichwertigen Batterietyp nach Empfehlung des Herstellers ersetzen. Gebrauchte Batterien nach Anweisungen des Herstellers beseitigen.



ALLE LÄNDER: Installation muß örtlichen und nationalen elektrischen Vorschriften entsprechen.



Warnung: Bei zentralisierten Gleichstromverbindungen sollte die Installation nur an einem Standort mit beschränktem Zugang erfolgen.



Hinweis: Für den Anschluß der Stromquelle ist ein für den Einsatz in Kabelrinnen geeignetes Installationskabel (Tray Cable) erforderlich, falls die Einheit durch zentralisierten Gleichstrom angetrieben wird. Das Installationskabel muß ein dem UL-Standard entsprechendes Kabel des Typs TC mit einer Nennspannung von 600 V und einer Nenntemperatur von 90 Grad C sein, das drei Leiter hat. Stärke mind. 12 AWG (American Wire Gauge – amerikanische Einheit für Drahtdurchmesser).



Warnung: INSTALLATION UND WARTUNG DIESER EINRICHTUNG NUR DURCH AUSGEBILDETES FACHPERSONAL.



Warnung: Aus Sicherheitsgründen sollte am Netzteilende des mit dieser LAN-Einrichtung verwendeten Kabels ein 15-Ampere-Leistungsschalter installiert werden.

Nehmen Sie STETS zuerst die Verkabelung der LAN-Einrichtung vor, bevor Sie die Kabel an den Leistungsschalter anschließen. Arbeiten Sie nie mit SPANNUNGSFÜHRENDEN Kabeln, um Körperverletzungen durch Stromschlag zu vermeiden. Achten Sie stets darauf, daß sich der Leistungsschalter in der Position Off (Aus) befindet, bevor Sie Kabel an den Leistungsschalter anschließen.



Warnung: Ziehen Sie nicht mehr als die empfohlene Drahtlänge ab. Wird mehr als die empfohlene Länge abisoliert, stellt dies ein Sicherheitsrisiko dar, da auf dem Anschlußklemmblock nach der Installation möglicherweise freiliegende Drähte verbleiben.



Warnung: Bei der Installation dieser Einrichtung ist stets sicherzustellen, daß der Masseanschluß jeweils zuerst installiert und zuletzt getrennt wird.



Warnung: "Sicherheitsrisiko" Prüfen Sie, daß aus dem installierten Draht keine freiliegenden Kupferlitzen herausragen. Bei korrekter Installation sollten aus dem Anschlußklemmblock keine freiliegenden Kupferlitzen vorstehen. Freiliegende Kabel führen genug Spannung, um Personen zu gefährden, die diese Drähte berühren.



Hinweis: Dieses System kann mit positiv geerdeten oder negativ geerdeten Gleichstromsystemen betrieben werden.

Sikkerhed



ADVARSEL: I et hjemligt miljø kunne dette produkt forårsage radio forstyrrelse. Bliver det tilfældet, påkræves brugeren muligvis at tage tilstrækkelige foranstaltninger.



ADVARSEL Laserprodukt av klasse I.



ADVARSEL Stirr ikke på strålen.



ELEKTRISKE FORHOLDSREGLER

ADVARSEL: RISIKO FOR ELEKTRISK STØD

For at forebygge ELEKTRISK stød, undlad at åbne apparatet. Der er ingen indre dele, der kan repareres af brugeren. Denne enhed indeholder LIVSFARLIGE STRØMSPÆNDINGER og bør kun åbnes af en uddannet og kvalificeret tekniker.



FARE UNDER UVEJR

FARE: UNDLAD at arbejde på udstyr eller KABLER i perioder med LYNAKTIVITET.



ADVARSEL: DEN STRØMFØRENDE LEDNING BRUGES TIL AT AFBRYDE STRØMMEN. SKAL STRØMMEN TIL APPARATET AFBRYDES, tages ledningen ud af stikket.



ELEKTRISK - KLASSE I-UDSTYR

DETTE UDSKYR KRÆVER JORDFORBINDELSE. Stikket skal være forbundet med en korrekt installeret jordforbunden stikkontakt. En ukorrekt installeret stikkontakt kan sætte livsfarlig spænding til tilgængelige metaldele.



UDSTYR TIL STIKKONTAKT, stikkontakten bør installeres nær ved udstyret og skal være lettilgængelig.



ADVARSEL: Ventilationsåbninger må ikke blokeres og skal have fri adgang til den omgivende luft i rummet for afkøling.



BETJENINGSTEMPERATUR: AT-8948, x900-48FE, x900-48FE-N, x900-48FS, AT-9900 series apparat er konstrueret til en omgivende temperatur på maksimum 50 grader C. AT-9924Ts, x900-12XT/S, x900-24XT, x900-24XT-N, x900-24XS, SwitchBlade x908 apparat er konstrueret til en omgivende temperatur på maksimum 40 grader C.



ELEKTRISK-OVERBELASTNING AF SPÆNDINGSKREDSLØBET

Ved installation af produktet, bør der tages hensyn til den kumulative kapacitet der angives på navneskiltet, når udstyret forbindes med vekselstrømsledningen.



ADVARSEL: MEKANISK OPSTILLING-Udstyret skal opstilles i stativet, på en sådan måde, at der ikke opstår fare p.g.a. ujævn opstilling.



Lithium batteri - Bør kun udskiftes af uddannet og kvalificeret tekniker.

ADVARSEL : Eksplosionsfare, hvis batteriet udskiftes ukorrekt. Udskift kun

med samme eller en tilsvarende type der anbefales af producenten. Kassér brugte batterier i overensstemmelse med producentens instruktioner.



ALLE LANDE: Installation af produktet skal ske i overensstemmelse med lokal og national lovgivning for elektriske installationer.



Advarsel: ETABLERES FORBINDELSEN TIL ET JÆVNSTRØMSNET, BØR INSTALLERING FORETAGES I ET OMRÅDE HVOR UVEDKOMMENDE IKKE HAR ADGANG.



Bemærk: Hvis switchen forbindes til jævnstrømsnet skal den føres med skinnekabel, der skal være UL mærket type TC normeret til 600 V, 90 grader C' med tre ledere af mindst tykkelse 12 AWG (amerikansk ledningsmål).



Advarsel: INSTALLERING OG UDSKIFTNING AF DETTE UDSTYR BØR KUN UDFØRES AF AUT. EL-INSTALLATØR.



Advarsel: Der bør indskydes en 15 A automatsikring på forsyningsenden af kablet til dette LAN-udstyr.

Man skal **ALTID** først forbinde ledningerne med LAN-udstyret inden de forbindes med automatsikringen. Ved ledningsarbejde skal strømmen altid være AFBRUDT til forebyggelse af fare for elektrisk stød. Man skal altid SLUKKE automatsikringen inden man forbinder ledninger med den.



Advarsel: Man bør ikke afisolere mere af ledningerne end anvist, for så kan sådanne blanke ledninger udgøre et faremoment efter montering på klemmerækken.



Advarsel: Ved installering af dette udstyr skal steljord altid forbindes først og aftages sidst.



Advarsel: "Fare" Se omhyggeligt efter om der stikker blanke kobbertråde ud fra klemmeforbindelserne. Ved korrekt montering er det ikke tilfældet. Enhver afisoleret leder kan lede farlig strømstyrke til personer, som kommer til at røre ved dem.



Bemærk: Dette udstyr kan køre både på jævnstrøm med positiv og med negativ jord.

Veiligheid



WAARSCHUWING: Binnenshuis kan dit product radiostoring veroorzaken, in welk geval de gebruiker verplicht kan worden om gepaste maatregelen te nemen.



WAARSHUWING Klasse-I laser produkt.



WAARCHUWING Neit in de straal staren.



WAARSCHUWINGEN MET BETREKKING TOT ELEKTRICITEIT

WAARSCHUWING: GEVAAR VOOR ELEKTRISCHE SCHOKKEN

Verwijder het deksel niet, teneinde ELEKTRISCHE schokken te voorkomen. Binnenin bevinden zich geen onderdelen die door de gebruiker onderhouden kunnen worden. Dit toestel staat onder GEVAARLIJKE SPANNING en mag alleen worden geopend door een daartoe opgeleide en bevoegde technicus.



GEVAAR VOOR BLIKSEMINSLAG

GEVAAR: NIET aan toestellen of KABELS WERKEN bij BLIKSEM.



WAARSCHUWING: HET TOESTEL WORDT UITGESCHAKELD DOOR DE STROOMKABEL TE ONTKOPPELEN. OM HET TOESTEL STROOMLOOS TE MAKEN: de stroomkabel ontkoppelen.



ELEKTRISCHE TOESTELLEN VAN KLASSE I
DIT TOESTEL MOET GEAARD WORDEN. De stekker moet aangesloten zijn op een juist geaarde contactdoos. Een onjuist geaarde contactdoos kan de metalen onderdelen waarmee de gebruiker eventueel in aanraking komt onder gevaarlijke spanning stellen.



AAN TE SLUITEN APPARATUUR, de contactdoos wordt in de nabijheid van de apparatuur geïnstalleerd en is gemakkelijk te bereiken.”



OPGELET: De ventilatiegaten mogen niet worden gesperd en moeten de omgevingslucht ongehinderd toelaten voor afkoeling.



BEDRIJFSTEMPERATUUR: De omgevingstemperatuur voor AT-8948, x900-48FE, x900-48FE-N, x900-48FS, AT-9900 series produkt mag niet meer bedragen dan 50 graden C. De omgevingstemperatuur voor AT-9924Ts, x900-12XT/S, x900-24XT, x900-24XT-N, x900-24XS, SwitchBlade x908 produkt mag niet meer bedragen dan 40 graden C.



ELEKTRISCH: OVERBELASTING VAN WISSELSTROOM HOOFDCIRCUIT

Tijdens de installatie van het produkt dient men rekening te houden met de gecombineerde waarden op de naamplaatjes bij het aansluiten van het toestel op de wisselstroom-voedingsdraden.



OPGELET: MECHANISCH LADEN - De montage van het toestel in het rek dient zo uitgevoerd te worden dat geen gevaar ontstaat door een ongelijke lading.



Lithium batterij. Mag alleen worden vervangen door een daartoe opgeleide en bevoegde technicus.

OPGELET: Gevaar voor ontploffing indien de batterij verkeerd wordt vervangen. Alleen vervangen door hetzelfde of een gelijkwaardig, door de fabrikant aanbevolen type.



ALLE LANDEN: het toestel installeren overeenkomstig de lokale en nationale elektrische voorschriften.



Waarschuwing: BIJ GECENTRALISEERDE DC-AANSLUITING: INSTALLATIE UITSLUITEND UITVOEREN IN EEN GEBIED MET BEPERKTE TOEGANG.



Opmerking: U hebt een PVC/nylon-kabel nodig voor aansluiting op de voedingsbron als de eenheid van stroom wordt voorzien door een gecentraliseerde DC-voeding. De PVC/nylon-kabel moet een TC-kabel zijn (met een vermelding op de UL-lijst), die geschikt is voor 600 V en 90 graden C met drie geleiders en een minimumdikte van 12 AWG.



Waarschuwing: ALLEEN GESCHOOLD EN GEKWALIFICEERD PERSONEEL MAG DEZE APPARATUUR INSTALLEREN OF VERVANGEN.



Waarschuwing: Op de kabel die op de LAN-apparatuur wordt aangesloten dient een zekering van 15 amp te worden gemonteerd aan de zijde van de aansluiting op de voeding.

Sluit bedrading **ALTIJD** eerst op de LAN-apparatuur aan en pas daarna op de zekering. Voorkom het risico op een elektrische schok en schakel eerst de voeding uit. Controleer voordat u de bedrading op de zekering aansluit altijd of de zekering zich in de stand UIT bevindt.



Waarschuwing: Verwijder niet meer dan de aanbevolen hoeveelheid isolatiemateriaal. Als u meer dan de aanbevolen hoeveelheid verwijdert, kan dit een veiligheidsrisico veroorzaken doordat draden bloot blijven liggen na aansluiting op het blok.



Waarschuwing: Zorg er tijdens installatie van de apparatuur altijd voor dat de aardeaansluiting van het frame als eerste wordt geplaatst en als laatste wordt losgemaakt.



Waarschuwing: “Veiligheidsrisico” Controleer of er bij de aangesloten bedrading geen koper blootligt. Als de installatie juist is uitgevoerd, is er bij het aansluitblok geen koperdraad zichtbaar. Blootliggende bedrading kan schadelijke elektriciteitsniveaus geleiden naar personen die met de draden in aanraking komen.



Opmerking: Dit systeem werkt met positief geaarde of negatief geaarde DC-systemen.

Sécurité



MISE EN GARDE : dans un environnement domestique, ce produit peut provoquer des interférences radioélectriques. Auquel cas, l'utilisateur devra prendre les mesures adéquates.



ATTENTION Produit laser de classe I.



ATTENTION Ne pas fixer le faisceau des yeux.



INFORMATION SUR LES RISQUES ÉLECTRIQUES

AVERTISSEMENT: DANGER D'ÉLECTROCUTION

Pour éviter toute ÉLECTROCUTION, ne pas ôter le revêtement protecteur du matériel. Ce matériel ne contient aucun élément réparable par l'utilisateur. Il comprend des TENSIONS DANGEREUSES et ne doit être ouvert que par un technicien dûment qualifié.



DANGER DE Foudre

DANGER: NE PAS MANIER le matériel ou les CÂBLES lors d'activité orageuse.



ATTENTION: LE CORDON D'ALIMENTATION SERT DE MISE HORS CIRCUIT. POUR COUPER L'ALIMENTATION DU MATÉRIEL, débrancher le cordon.



ÉQUIPEMENT DE CLASSE I ÉLECTRIQUE

CE MATÉRIEL DOIT ÊTRE MIS A LA TERRE. La prise de courant doit être branchée dans une prise femelle correctement mise à la terre car des tensions dangereuses risqueraient d'atteindre les pièces métalliques accessibles à l'utilisateur.



EQUIPEMENT POUR BRANCHEMENT ELECTRIQUE, la prise de sortie doit être placée près de l'équipement et facilement accessible".



ATTENTION: Ne pas bloquer les fentes d'aération, ceci empêcherait l'air ambiant de circuler librement pour le refroidissement.



TEMPÉRATURE DE FONCTIONNEMENT: AT-8948, x900-48FE, x900-48FE-N, x900-48FS, AT-9900 series est capable de tolérer une température ambiante maximum de ou 50 degrés C. AT-9924Ts, x900-12XT/S, x900-24XT, x900-24XT-N, x900-24XS, SwitchBlade x908 est capable de tolérer une température ambiante maximum de ou 40 degrés C.



SURCHARGE DES CIRCUITS PRINCIPAUX DE COURANT ALTERNATIF ÉLECTRIQUE

Lors de l'installation du matériel, il faut prendre en compte la somme des puissances indiquées sur les étiquettes au moment de connecter le matériel à une source de courant alternatif.



ATTENTION : RÉPARTITION DE LA CHARGE MÉCANIQUE - Le montage du matériel dans le bâti doit être effectué de telle manière que la répartition de la charge mécanique ne pose aucun danger.



Pile en Lithium-Doit uniquement être remplacée par un technicien dûment qualifié

ATTENTION : Un danger d'explosion existe en cas de remplacement incorrect de la pile. Remplacer uniquement avec une pile du même type ou d'un type recommandé par le fabricant. Mettre au rebut les piles usagées conformément aux instructions du fabricant).



POUR TOUS PAYS: Installer le matériel conformément aux normes électriques nationales et locales.



Avertissement: POUR UNE CONNEXION A UNE SOURCE D'ALIMENTATION C.C. CENTRALISEE, L'INSTALLATION DOIT ETRE UNIQUEMENT EFFECTUEE DANS UNE ZONE D'ACCES LIMITE.



Remarque: Un câble de chariot est requis pour connecter la source de courant si l'unité est alimentée par une source de C.C. centralisée. Il doit s'agir d'un câble agréé UL de type TC, d'une puissance de 600 V et de 90 degrés C, avec trois fils conducteurs et un calibre minimum de 12 AWG (norme américaine exprimant la section des fils).



Avertissement: SEUL UN PERSONNEL QUALIFIE ET ENTRAINE EST AUTORISE A INSTALLER OU REMPLACER CET EQUIPEMENT.



Avertissement: Par mesure de sécurité, un disjoncteur de 15 A doit être installé au point d'alimentation électrique du câble devant être utilisé avec cet équipement de réseau local (LAN).

Connectez **TOUJOURS** le câblage à l'équipement LAN avant de le connecter au disjoncteur. Pour éviter tout risque de blessure corporelle par électrocution, ne travaillez pas lorsque le matériel est sous tension. Assurez-vous toujours que le disjoncteur est bien en position d'ARRET avant de le connecter au câblage.



Avertissement: Ne coupez pas une quantité de câble supérieure à celle qui est recommandée. Cela pourrait constituer un risque de sécurité en laissant du câblage à nu sur le bornier après l'installation.



Avertissement: Lors de l'installation de cet équipement, vérifiez toujours que la connexion de terre du châssis est installée en premier et débranchée en dernier.



Avertissement: "Risque de sécurité" Vérifiez qu'aucun fil de cuivre dénudé ne sort du câble installé. Lorsque cette installation est effectuée correctement, aucun fil de cuivre ne devrait dépasser du bornier. Tout câblage dénudé peut être conducteur de tensions dangereuses pour les personnes touchant les câbles.



Remarque: Ce système peut fonctionner avec des systèmes C.C. dotés d'une mise à la terre positive ou négative.

Turvallisuus



VAROITUS: Kotiolosuhteissa tämä laite voi aiheuttaa radioaaltojen häiröitä, missä tapauksessa laitteen käyttäjän on mahdollisesti ryhdyttävä tarpeellisiin toimenpiteisiin.



VAROITUS Luokan I Lasertuote.



VAROITUS Älä katso säteeseen.



SÄHKÖÖN LIITTYVIÄ HUOMAUTUKSIA

VAROITUS: SÄHKÖISKUVAARA

Estääksesi SÄHKÖISKUN älä poista kantta. Sisällä ei ole käyttäjän huollettavissa olevia osia. Tämä laite sisältää VAARALLISIA JÄNNITTEITÄ ja sen voi avata vain koulutettu ja pätevä teknikko.



SALAMANISKUVAARA

HENGENVAARA: ÄLÄ TYÖSKENTELE laitteiden tai KAAPELEIDEN KANSSA SALAMOINNIN AIKANA.



HUOMAUTUS: VIRTAJOHTOA KÄYTETÄÄN

VIRRANKATKAISULAITTEENA. VIRTA KATKAISTAAN irrottamalla virtajohto.



SÄHKÖ - TYYPPILUOKAN I LAITTEET

TÄMÄ LAITE TÄYTY MAADOITTA. Pistoke täytyy liittää kunnollisesti maadoitettuun pistorasiaan. Virheellisesti johdotettu pistorasia voi altistaa metalliosat vaarallisille jännitteille.



PISTORASIAAN KYTKETTÄVÄ LAITE; pistorasia on asennettava laitteen lähelle ja siihen on oltava esteetön pääsy.”



HUOMAUTUS: Ilmavaihtoreikiä ei pidä tukkia ja niillä täytyy olla vapaa yhteys ympäröivään huoneilmaan, jotta ilmanvaihto tapahtuisi.



KÄYTTÖLÄMPÖTILA: Tämä AT-8948, x900-48FE, x900-48FE-N, x900-48FS, AT-9900 series katkaisin on suunniteltu ympäröivän ilman maksimilämpötilalle 50° C. Tämä AT-9924Ts, x900-12XT/S, x900-24XT, x900-24XT-N, x900-24XS, SwitchBlade x908 tuote on suunniteltu ympäröivän ilman maksimilämpötilalle 40° C.



SÄHKÖ-VAIHTORVIRTASÄHKÖPIIRIN YLIKUORMITUS

Tuotetta asennettaessa on otettava huomioon osien nimikilvissä osoitettu teho silloin kun osat liitetetään vaihtovirtaverkkoon.



HUOMAUTUS: MEKAANINEN KUORMITUS--Osien asennuksen alustaan tulee tapahtua siten, että epätasainen kuormitus ei aiheuta vaaraa.



Litiumparisto - Vaihdon voi suorittaa vain koulutettu ja pätevä teknikko.

Varoitus: Räjähdyksivaara, jos paristo on vaihdettu väärin. Vaihda vain samaan tai vastaavaan tyyppiin, jota valmistaja suosittelee. Hävitä käytetyt paristot valmistajan ohjeiden mukaan.



KAIKKI MAAT: Asenna tuote paikallisten ja kansallisten sähköturvallisuusmääräysten mukaisesti.



Varoitus: KESKITETTY TASAVIRTAKYTKENTÄ ASENNETTAVA AINOASTAAN TILAAN, JOHON ON RAJOITETTU PÄÄSY.



Huomaa: Virtalähteen kytkemiseen tarvitaan levykaapeli, jos yksikkö saa tehonsa keskitetystä tasavirtalähteestä. Levykaapelin on oltava UL-luetteloitu tyyppiin TC levykaapeli ja nimellisarvoiltaan 600 V ja 90° C, kolmijohtiminen, minimi 12 AWG (American Wire Gauge -lankamitta).



Varoitus: TÄMÄN LAITTEEN SAA ASENTAA TAI VAIHTAA AINOASTAAN KOULUTETTU JA AMMATTITAITOINEN HENKILÖKUNTA.



Varoitus: Tämän LAN-laitteen kanssa käytettävän kaapelin syöttöpäähän tulee turvallisuusyistä asentaa 15 A virrankatkaisin.

Yhdistä johdot AINA ensin LAN-laitteeseen ennen virrankatkaisimeen kytkemistä. Sähköiskusta johtuvien vammojen välttämiseksi älä käsittele JÄNNITTEELLISIÄ johtoja. Varmista aina, että virrankatkaisin on pois päältä (off) ennen kuin yhdistät johdot katkaisimeen.



Varoitus: Älä poista johtimesta päällystettä enempiä kuin on suositeltu. Päällysteen poistaminen suositusta pidemmältä matkalta voi aiheuttaa turvallisuusriskin, sillä riviliittimeen jää asennuksen jälkeen paljaita johtimia.



Varoitus: Kun asennat tätä laitetta, varmista aina, että runkomaadoitettu liitin kytketään ensin ja irrotetaan viimeiseksi.



Varoitus: Turvallisuusriski Tarkista, ettei asennetusta johtimesta näy paljaita kuparisäikeitä. Kun asennus suoritetaan oikein, riviliittimestä ei pitäisi näkyä paljaita kuparijohdinsäikeitä. Paljaat johtimet voivat aiheuttaa sähköiskuvaaran, jos niihin kosketaan.



Huomaa: Tämä järjestelmä toimii positiivisesti tai negatiivisesti maadoitettujen tasavirtajärjestelmien kanssa.

Norme di Sicurezza



AVVERTENZA: in ambiente domestico questo prodotto potrebbe causare radio interferenza. In questo caso potrebbe richiedersi all'utente di prendere gli adeguati provvedimenti.



AVVERTENZA Prodotto laser di Classe I.



AVERTENZA Non fissare il raggio con gli occhi.



AVVERTENZE ELETTRICHE

ATTENZIONE: PERICOLO DI SCOSSE ELETTRICHE

Per evitare SCOSSE ELETTRICHE non asportare il coperchio. Le componenti interne non sono riparabili dall'utente. Questa unità ha TENSIONI PERICOLOSE e va aperta solamente da un tecnico specializzato e qualificato.



PERICOLO DI FULMINI

PERICOLO: NON LAVORARE sul dispositivo o sui CAVI durante PRECIPITAZIONI TEMPORALESCHIE.



ATTENZIONE: IL CAVO DI ALIMENTAZIONE È USATO COME DISPOSITIVO DI DISATTIVAZIONE. PER TOGLIERE LA CORRENTE AL DISPOSITIVO staccare il cavo di alimentazione.



ELETTRICITÀ - DISPOSITIVI DI CLASSE I

QUESTO DISPOSITIVO DEVE AVERE LA MESSA A TERRA. La spina deve essere inserita in una presa di corrente specificamente dotata di messa a terra. Una presa non cablata in maniera corretta rischia di scaricare una tensione pericolosa su parti metalliche accessibili.



APPARECCHIATURA COLLEGABILE, la presa va installata vicino all'apparecchio per risultare facilmente accessibile”.



ATTENZIONE: le prese d'aria non vanno ostruite e devono consentire il libero ricircolo dell'aria ambiente per il raffreddamento.



TEMPERATURA DI FUNZIONAMENTO: AT-8948, x900-48FE, x900-48FE-N, x900-48FS, AT-9900 series prodotto è concepito per una temperatura ambientale massima di 50 gradi C. AT-9924Ts, x900-12XT/S, x900-24XT, x900-24XT-N, x900-24XS, SwitchBlade x908 prodotto è concepito per una temperatura ambientale massima di 40 gradi C.



ELETTRICITÀ - SOVRACCARICO DEL CIRCUITO DI RETE A C.A.

Durante l'installazione ed il collegamento del dispositivo alla rete di alimentazione a corrente alternata, è necessario tenere in considerazione le capacità cumulative riportate sulla targhetta.



ATTENZIONE: CARICAMENTO MECCANICO - Il montaggio del dispositivo sul supporto va effettuato in maniera tale da evitare qualsiasi potenziale condizione di pericolo eventualmente dovuta al montaggio irregolare.



Batteria al litio - Va sostituita solo da un tecnico specializzato e qualificato.

ATTENZIONE: l'errata sostituzione della batteria può causare pericolo di esplosioni. Sostituire solamente con lo stesso tipo o con uno equivalente raccomandato dal produttore. Eliminare le batterie usate secondo le istruzioni del produttore.



TUTTI I PAESI: installare il prodotto in conformità delle vigenti normative elettriche nazionali.



Avvertenza: AI FINI DEL COLLEGAMENTO CENTRALIZZATO DI ALIMENTAZIONE A CC, INSTALLARE SOLO IN UN'AREA AD ACCESSO LIMITATO.



Nota: Se l'unità è alimentata a corrente continua centralizzata, per collegare l'alimentatore è necessario un cavo a piatto di tipo TC, listato UL, avente caratteristiche nominali di tensione e temperatura di 600 V e 90gradi C, tre conduttori ed un diametro minimo di 12 AWG.



Avvertenza: L'INSTALLAZIONE E LA SOSTITUZIONE DI QUESTA APPARECCHIATURA DEVONO ESSERE EFFETTUATE SOLAMENTE DA PERSONALE SPECIALIZZATO E QUALIFICATO.



Avvertenza: A titolo di cautelativo, installare un interruttore di sicurezza da 15 ampere sull'estremità in entrata del cavo di alimentazione di questa apparecchiatura LAN.

Collegare **SEMPRE il cablaggio** prima all'apparecchiatura LAN e poi all'interruttore. Per evitare i infortuni causati da folgorazione, non lavorare su cavi SOTTO TENSIONE. Prima di collegare il cavo all'interruttore di sicurezza, accertarsi sempre che quest'ultimo sia disinserito.



Avvertenza: Per evitare i possibili pericoli associati all'esposizione dei fili sulla morsettiera dopo l'installazione, non rimuovere l'isolamento oltre le misure specificate.



Avvertenza: Quando si installa questo apparecchio, accertarsi sempre che il collegamento a massa del telaio sia sempre il primo ad essere effettuato e l'ultimo ad essere scollegato.



Avvertenza: "Pericolo!" Controllare che il filo installato non abbia trefoli in rame esposti. Se l'installazione è stata effettuata in modo corretto, non vi deve protrudere dalla morsettiera alcun trefolo in rame esposto. In caso di contatto, un filo esposto può condurre livelli di elettricità pericolosi a quanti lo tocchino.



Nota: Questo sistema funziona con sistemi a CC con massa positiva o negativa.

Sikkerhet



ADVARSEL: Hvis dette produktet benyttes til privat bruk, kan produktet forårsake radioforstyrrelse. Hvis dette skjer, må brukeren ta de nødvendige forholdsregler.



ADVARSEL Laserprodukt av klasse I.



ADVARSEL Stirr ikke på strålen.



ELEKTRISITET

ADVARSEL: FARE FOR ELEKTRISK SJOKK

For å unngå ELEKTRISK sjokk, må dekslet ikke tas av. Det finnes ingen deler som brukeren kan reparere på innsiden. Denne enheten inneholder FARLIGE SPENNINGER, og må kun åpnes av en faglig kvalifisert tekniker.



FARE FOR LYNNEDSLAG

FARE: ARBEID IKKE på utstyr eller KABLER i TORDENVÆR.



FORSIKTIG: STRØMLEDNINGEN BRUKES TIL Å FRAKOBLE UTSTYRET. FOR Å DEAKTIVISERE UTSTYRET, må strømforsyningen kobles fra.



ELEKTRISK - TYPE I- KLASSE UTSTYR

DETTE UTSTYRET MÅ JORDES. Strømkontakten må være tilkopleet en korrekt jordet kontakt. En kontakt som ikke er korrekt jordet kan føre til farlig spenninger i lett tilgjengelige metalldeleer.



UTSTYR FOR STIKKONTAKT. Stikkontakten skal monteres i nærheten av utstyret og skal være lett tilgjengelig.”



FORSIKTIG: Lufteventilene må ikke blokkeres, og må ha fri tilgang til luft med romtemperatur for avkjøling.



DRIFTSTEMPERATUR: AT-8948, x900-48FE, x900-48FE-N, x900-48FS, AT-9900 series produktet er konstruert for bruk i maksimum romtemperatur på 50 grader C. AT-9924Ts, x900-12XT/S, x900-24XT, x900-24XT-N, x900-24XS, SwitchBlade x908 produktet er konstruert for bruk i maksimum romtemperatur på 40 grader C.



ELEKTRISK OVERBELASTNING PÅ AC HOVEDKRETSLØP

Når produktet installeres, må de samlede navneplateverdierne kontrolleres nøye når strøm påsettes.



FORSIKTIG: MEKANISK LASTNING Installering av utstyret på hyllen må utføres på en slik måte at ingen farlige situasjoner oppstår som en følge av ujevn lastning.



Litiumbatteri — Må kun byttes ut av en faglig kvalifisert tekniker.

FORSIKTIG: Eksplosjonsfare hvis batteriet feilinnsettes. Batteriet må bare erstattes med samme type eller en tilsvarende type som er anbefalt av fabrikanten. Batteriene må kasseres i samsvar med fabrikantens instruksjoner.



ALLE LAND: Produktet må installeres i samsvar med de lokale og nasjonale elektriske koder.



Advarsel: VED TILKOPLING TIL ET LIKESTRØMSNETT, SKAL DU BARE MONTERE UTSTYRET PÅ ET STED HVOR UVEDKOMNE IKKE HAR ADGANG.



Merknad: En kanalkabel er nødvendig for å kople til strømkilden hvis enheten drives av strøm fra et likestrømsnett. Kanalkabelen må være utstyrt med UL-merke med type TC, normert for 600 V og 90 grader C med tre ledere som har en tykkelse på minst 12AWG (amerikansk ledningsmål).



Advarsel: DETTE UTSTYRET SKAL BARE MONTERES ELLER SKIFTES UT AV KVALIFISERT PERSONELL SOM HAR GJENNOMGÅTT OPPLÆRING.



Advarsel: Av sikkerhetshensyn bør en automatsikring på 15 A monteres i forsyningsenden av kabelen som skal brukes sammen med dette LAN-utstyret.

Du skal ALLTID først kople ledningene til LAN-utstyret før du kople ledningene til automatsikringen. Arbeid aldri med ledninger uten at strømmen er slått av, ettersom det ellers kan være fare for personskader som følge av elektrisk støt. Pass alltid på at automatsikringer er slått AV før du kople ledningene til automatsikringen.



Advarsel: Du skal ikke avisolere mer av ledningen enn det som er anbefalt. Dersom du avisolerer mer enn det som er anbefalt, kan dette forårsake en sikkerhetsfare, ettersom det vil finnes uisolert ledning på rekkeklemmen etter montering.



Advarsel: Når du monterer dette utstyret, skal du alltid passe på at forbindelsen til rammejordingen monteres først og koples fra sist.



Advarsel: "Sikkerhetsfare" Kontroller om uisolerte koppertråder stikker ut av den monterte ledningen. Hvis monteringen er riktig utført, skal det ikke finnes uisolerte kobbertråder som stikker ut fra rekkeklemmen. Uisolerte ledninger kan lede skadelige mengder strøm til personer som berører ledningene.



Merknad: Systemet fungerer med positivt og negativt jordede likestrømssystemer.

Segurança



AVISO: Num ambiente doméstico este produto pode causar interferência na radiorrecepção e, neste caso, pode ser necessário que o utente tome as medidas adequadas.



AVISO Produto laser de classe I



AVISO Não olhe fixamente para o raio.



AVISOS SOBRE CARACTERÍSTICAS ELÉTRICAS

ATENÇÃO: PERIGO DE CHOQUE ELÉTRICO

Para evitar CHOQUE ELÉTRICO, não retire a tampa. Não contém peças que possam ser consertadas pelo usuário. Este aparelho contém VOLTAGENS PERIGOSAS e só deve ser aberto por um técnico qualificado e treinado.



PERIGO DE CHOQUE CAUSADO POR RAIOS

PERIGO: NÃO TRABALHE no equipamento ou nos CABOS durante períodos suscetíveis a QUEDAS DE RAIOS.



CUIDADO: O CABO DE ALIMENTAÇÃO É UTILIZADO COMO UM DISPOSITIVO DE DESCONEXÃO. PARA DESELETRIFICAR O EQUIPAMENTO, desconecte o cabo de ALIMENTAÇÃO.



ELÉTRICO - EQUIPAMENTOS DO TIPO CLASSE I DEVE SER FEITA LIGAÇÃO DE FIO TERRA PARA ESTE EQUIPAMENTO. O plugue de alimentação deve ser conectado a uma tomada com adequada ligação de fio terra. Tomadas sem adequada ligação de fio terra podem transmitir voltagens perigosas a peças metálicas expostas.



EQUIPAMENTO DE LIGAÇÃO, a tomada eléctrica deve estar instalada perto do equipamento e ser de fácil acesso.”



CUIDADO: As aberturas de ventilação não devem ser bloqueadas e devem ter acesso livre ao ar ambiente para arrefecimento adequado do aparelho.



TEMPERATURA DE FUNCIONAMENTO: AT-8948, x900-48FE, x900-48FE-N, x900-48FS, AT-9900 series produto foi projetado para uma temperatura ambiente máxima de 50 graus C. AT-9924Ts, x900-12XT/S, x900-24XT, x900-24XT-N, x900-24XS, SwitchBlade x908 produto foi projetado para uma temperatura ambiente máxima de 40 graus C.



ELÉTRICO - SOBRECARGA DA REDE DE CORRENTE ALTERNADA (AC)

Antes de instalar o produto, verifique o efeito cumulativo da conexão de diversos aparelhos à rede de corrente alternada através das etiquetas que indicam potência ou amperagem.



CUIDADO: CARREGAMENTO - O equipamento deverá ser montado no suporte de montagem de forma tal que não cause perigo devido a carregamento não uniforme.



Bateria de lítio - Só deve ser trocada por técnico qualificado e treinado.

CUIDADO: Se a bateria não for devidamente instalada há perigo de explosão. Substitua somente pelo mesmo tipo ou equivalente, conforme recomendado pelo fabricante. Descarte baterias usadas, de acordo com as instruções fornecidas pelo fabricante.



TODOS OS PAÍSES: Instale o produto de acordo com as normas nacionais e locais para instalações elétricas.



Aviso: PARA UMA LIGAÇÃO CC CENTRALIZADA, INSTALE APENAS NUMA ZONA DE ACESSO RESTRITO.



Nota: É necessário um cabo de bandeja para ligar a fonte de energia se a unidade for alimentada por um fonte CC centralizada. O cabo de bandeja deve fazer parte da lista UL do Tipo TC cabo de bandeja para 600 V e 90 graus C, com três condutores, com um mínimo de 12 AWG.



Aviso: SÓ PESSOAL TREINADO E QUALIFICADO PODE INSTALAR OU SUBSTITUIR ESTE EQUIPAMENTO.



Aviso: Como medida de precaução, deve instalar-se um disjuntor de 15 Amp na extremidade de alimentação do cabo a ser usado com este equipamento LAN.

Ligue **SEMPRE** os cabos ao equipamento LAN primeiro antes de os ligar ao disjuntor. Para evitar o perigo de ferimentos por choque eléctrico, não trabalhe com alimentadores LIGADOS. Verifique sempre se o disjuntor está na posição OFF (desligado) antes de ligar os cabos ao mesmo.



Aviso: Não corte mais fio do que recomendado. Cortar mais do que o recomendado pode ser perigoso, por deixar fio exposto no terminal depois da instalação.



Aviso: Ao ligar este equipamento, instale sempre primeiro a ligação à terra e desligue-a sempre em último.



Aviso: “Perigo” Verifique se há algum fio de cobre exposto a sair do fio instalado. Quando esta instalação é feita correctamente não deve haver qualquer fio de cobre exposto a sair do terminal. Qualquer fio exposto pode conduzir níveis perigosos de electricidade para a pessoa que toque nos fios.



Nota: Este sistema funciona com sistemas CC com ligações à terra Positivas ou Negativas.

Seguridad



ADVERTENCIA: en un entorno doméstico, este producto puede causar radiointerferencias, en cuyo caso, puede requerirse del usuario que tome las medidas que sean convenientes al respecto.



¡**ADVERTENCIA!** Producto láser Clase I.



¡**ADVERTENCIA!** No mirat fijamente el haz.



AVISOS ELECTRICOS

ADVERTENCIA: PELIGRO DE ELECTROCHOQUE

Para evitar un ELECTROCHOQUE, no quite la tapa. No hay ningún componente en el interior al cual puede prestar servicio el usuario. Esta unidad contiene VOLTAJES PELIGROSOS y sólo deberá abrirla un técnico entrenado y calificado.



PELIGRO DE RAYOS

PELIGRO: NO REALICE NINGUN TIPO DE TRABAJO O CONEXION en los equipos o en LOS CABLES durante TORMENTAS ELECTRICAS.



ATENCION: EL CABLE DE ALIMENTACION SE USA COMO UN DISPOSITIVO DE DESCONEXION. PARA DESACTIVAR EL EQUIPO, desconecte el cable de alimentación.



ELECTRICO - EQUIPO DEL TIPO CLASE I

ESTE EQUIPO TIENE QUE TENER CONEXION A TIERRA. El cable tiene que conectarse a un enchufe a tierra debidamente instalado. Un enchufe que no está correctamente instalado podría ocasionar tensiones peligrosas en las partes metálicas que están expuestas.



EQUIPO CONECTABLE, el tomacorriente se debe instalar cerca del equipo, en un lugar con acceso fácil”.



ATENCION: Las aberturas para ventilación no deberán bloquearse y deberán tener acceso libre al aire ambiental de la sala para su enfriamiento.



TEMPERATURA REQUERIDA PARA LA OPERACIÓN: AT-8948/

x900-48/AT-9900 producto está diseñado para una temperatura ambiental máxima de 50 grados C. AT-9924Ts, x900-12XT/S, x900-24XT, x900-24XT-N, x900-24XS, SwitchBlade x908 producto está diseñado para una temperatura ambiental máxima de 40 grados C.



ELECTRICO - SOBRECARGA DEL CIRCUITO PRIMARIO DE CORRIENTE ALTERNA

Al instalarse el producto deberán considerarse las potencias nominales acumulativas, cuando se conecta el equipo al cable de alimentación de corriente alterna.



ATENCIÓN: CARGA MECANICA - El montaje del equipo en el bastidor debe realizarse de manera tal que no cause una condición peligrosa debido a la distribución desigual del peso.



Batería de litio - Sólo deberá ser cambiada por un técnico entrenado y calificado.
ATENCIÓN: Peligro de explosión si la batería no se reemplaza en forma correcta. Reemplace sólo con el mismo tipo o equivalente que recomienda el fabricante. Deseche las baterías usadas según las instrucciones del fabricante.



PARA TODOS LOS PAÍSES: Monte el producto de acuerdo con los Códigos Eléctricos locales y nacionales.



Advertencia: PARA HACER CONEXIONES DE CC CENTRALIZADAS, INSTALE EL CONMUTADOR ÚNICAMENTE EN LUGARES CON ACCESO RESTRINGIDO.



Nota: Para conectar la fuente de alimentación, se necesita un cable de bastidor si el aparato es activado por una fuente de alimentación de CC. El cable de bastidor debe figurar en la lista de UL, ser de tipo TC, tener una clasificación de 600 V y 90 grados C, y disponer de tres conductores con un mínimo de 12 según el Patrón de Medidas Estadounidense (AWG - American Wire Gage).



Advertencia: ÚNICAMENTE EMPLEADOS CAPACITADOS Y COMPETENTES TIENEN LA AUTORIZACIÓN DE INSTALAR O REPONER DICHO EQUIPO.



Advertencia: Por razones de precaución, se debe instalar un cortacircuitos de 15 amperios en el extremo de alimentación del cable que se utilizará con este equipo LAN.

SIEMPRE conecte los cables al equipo LAN primero, antes de conectarlos al cortacircuitos. Para evitar el peligro de sufrir daños corporales a causa de sacudidas eléctricas, no trabaje con conductores **CON CORRIENTE**. Asegúrese siempre de que el cortacircuitos esté en la posición de **APAGADO (OFF)** antes de conectar los cables al cortacircuitos.



Advertencia: No pele el cable más de la cantidad recomendada, ya que si después de instalar el bloque terminal quedan cables pelados, habrá riesgos de seguridad.



Advertencia: Cuando instale dicho equipo, asegúrese siempre de que el bastidor se conecte a tierra primero y se desconecte por último.



Advertencia: “Riesgo de seguridad” Cerciórese de que no haya hilos de cobre pelados que salgan del alambre instalado. Cuando dicha instalación se realiza correctamente, los hilos de cobre pelados no deben salir del bloque terminal. Todo alambre pelado puede conducir niveles de electricidad nocivos a la persona que lo toca.



Nota: Este sistema funcionará con sistemas de CC con conexión positiva o negativa a tierra.

Säkerhet



WARNING: Denna produkt kan ge upphov till radiostörningar i hemmet, vilket kan tvinga användaren till att vidtaga erforderliga åtgärder.



WARNING! Laserprodukt av klass I.



WARNING! Laserstrålning när enheten är öppen.



TILLKÄNNAGIVANDEN BETRÄFFANDE ELEKTRICITETSRIK:
RISK FÖR ELEKTRISK STÖTFör att undvika ELEKTRISK stöt, ta ej av locket. Det finns inga delar inuti som behöver underhållas. Denna apparat är under HÖGSPÄNNING och får endast öppnas av en utbildad kvalificerad tekniker.



FARA FÖR BLIXTNEDSLAG

FARA: ARBETA EJ på utrustningen eller kablarna vid ÅSKVÄDER.



WARNING: NÄTKABELN ANVÄNDS SOM STRÖMBRYTARE FÖR ATT KOPPLA FRÅN STRÖMMEN, dra ur nätkabeln.



ELEKTRISKT - TYP KLASS I UTRUSTNING
DENNA UTRUSTNING MÅSTE VARA JORDAD. Nätkabeln måste vara ansluten till ett ordentligt jordat uttag. Ett felaktigt uttag kan göra att närliggande metalldelar utsätts för högspänning. Apparaten skall anslutas till jordat uttag, när den ansluts till ett nätverk.



UTRUSTNING MED PLUGG. Uttaget skall installeras i utrustningens närhet och vara lättåtkomligt”.



WARNING: Luftventilerna får ej blockeras och måste ha fri tillgång till omgivande rumsluft för avsvaning.



DRIFTSTEMPERATUR: AT-8948, x900-48FE, x900-48FE-N, x900-48FS, AT-9900 series produkt är konstruerad för rumstemperatur ej överstigande 50 grader C. AT-9924Ts, x900-12XT/S, x900-24XT, x900-24XT-N, x900-24XS, SwitchBlade x908 produkt är konstruerad för rumstemperatur ej överstigande 40 grader C.



ELEKTRISKT - ÖVERBELASTNING AV VÄXELSTRÖMSNÄTET: När produkten installeras bör den sammanlagda effekten på namnplåten beaktas när apparaten ansluts till växelströmsnätet.



WARNING: MEKANISK BELASTNING: Utrustningen ska installeras i chassit på så sätt att fara inte uppstår p g a ojämn belastning.



Litium batteri - Får endast bytas av utbildade och kvalificerade tekniker.
WARNING: Risk för explosion om felaktigt batteri används. Byt endast mot samma eller likvärdig typ batteri, rekommenderat av tillverkaren. Kassera använda batterier i enlighet med tillverkarens instruktioner.



ALLA LÄNDER: Installera produkten i enlighet med lokala och statliga bestämmelser för elektrisk utrustning.



Varning: ANSLUTNING TILL LIKSTRÖMSNÄT FÅR ENDAST SKE I LOKAL DÄR OBEHÖRIGA EJ ÄGER TILLTRÄDE.



Anmärkning: Kanalkabel krävs för att ansluta strömkällan om enheten ansluts till likströmsnät. Kanalkabeln måste vara UL-märkt och av TC-typ. Kabeln måste ha en märkspänning på 600 V och en märktemperatur på 90 grader C samt ha tre ledare med en tjocklek på minst 12 AWG (amerikanskt ledningsmått).



Varning: INSTALLATION OCH UTBYTE AV DENNA UTRUSTNING FÅR ENDAST UTFÖRAS AV AUKTORISERAD ELINSTALLATÖR.



Varning: Av säkerhetsskäl skall en 15 A automatsäkring anslutas till försörjningsänden på kabeln som används till denna LAN-utrustning.

Ledningar skall **ALLTID** anslutas till LAN-utrustningen innan ledningarna ansluts till automatsäkringen. För att förebygga uppkomsten av personsador orsakade av elektrisk stöt skall man inte vidröra strömförande uttag. Kontrollera alltid att automatsäkringen är i läget OFF (AV) innan anslutning av ledningar till automatsäkringen sker.



Varning: Skala inte av mer isolering än vad som anges ovan. Skalar för mycket isolering av kan fara uppstå om oskyddad tråd vidrörs på anslutningsplinten efter anslutningen.



Varning: Vid anslutning av denna utrustning skall man alltid se till att jordtråden ansluts först och lossas sist.



Varning: OBS! FARA! Kontrollera om små koppartrådar sticker ut ifrån den anslutna tråden. Om anslutningen utförts riktigt sticker inga trådar ut från anslutningsplinten. Oisolerade trådar kan överföra skadlig elektricitet till person som vidrör trådarna.



Anmärkning: Detta system fungerar både med positivt och negativt jordade likströmskällor.

EC Declaration of Conformity

We: **ALLIED TELESIS LABS LIMITED**
27 NAZARETH AVENUE
CHRISTCHURCH 8024
NEW ZEALAND

Declare under our sole legal responsibility that these products:

AT-8948, AT-9900 Series, AT-9924Ts, x900 Series,
SwitchBlade x908 Switches

Are in conformity with the essential requirements of directives:

- 2006/95/EC Low Voltage Directive including its amending directive 93/68/EEC
- 89/336/EEC Electromagnetic Compatibility (EMC) Directive including its amending directives 92/31/EC, 93/68/EEC and 2004/108/EC

with reference to the following harmonised standards:

- EN55022: 1998 Incl A1:2000 and A2:2003
Information Technology Equipment—Radio disturbance
- EN55024: 1998 Incl A1:2001 and A2:2003
Information Technology Equipment—Immunity characteristics—Limits and methods of measurement
- EN60825-1: 1994 Incl A1:2002 and A2:2001
Safety of Laser Products—part 1: Equipment classification, requirements and user's guide
- EN60950-1: 2001 Incl A11:2004
Information Technology Equipment including electrical business equipment—General Requirements
- EN61000-3-2: 2000 Incl A2:2005
Electromagnetic compatibility (EMC)—part 3-2: Limits for harmonic current emissions (equipment input current up to and including 16A per phase)
- EN61000-3-3: 1995 Incl A1:2001 and A2:2005
Electromagnetic compatibility (EMC)—part 3-3: Limitation of voltage fluctuations and flicker in low-voltage supply systems for equipment with rated current up to 16A

Name: John Shields
On behalf of the Manufacturer

Signature:



Position:
Vice President of Engineering
Date of issue: 17 August 2007
Place of issue: 27 Nazareth Ave