

## ORDERING REPLACEMENT PARTS

To order replacement parts, contact the ICON Health & Fitness, Ltd. office, or write:

ICON Health & Fitness, Ltd.  
Customer Service Department  
Unit 4, Revie Road Industrial Estate  
Revie Road  
Beeston  
Leeds, LS118JG  
UK

Tel:

**08457 089 009**

Outside the UK: (44) 113 387 7133  
Fax: (44) 113 387 7125

To help us assist you, please be prepared to give the following information:

- The MODEL NUMBER of the product (PETL75133)
- The NAME of the product (PROFORM® 760 AIR treadmill)
- The SERIAL NUMBER of the product (see the front cover of this manual)
- The KEY NUMBER AND DESCRIPTION OF THE PART(S) (see the PART LIST on pages 30 and 31 and the EXPLODED DRAWING attached in the centre of this manual)

# PRO-FORM 760 AIR CoolingBreeze

## USER'S MANUAL

Model No. PETL75133

Serial No. \_\_\_\_\_

Serial Number Decal

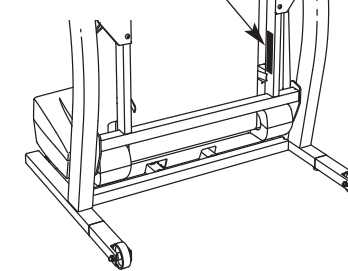

### QUESTIONS?

As a manufacturer, we are committed to providing complete customer satisfaction. If you have questions, or if there are missing or damaged parts, please call:

**08457 089 009**

Or write:  
ICON Health & Fitness, Ltd.  
Unit 4  
Revie Road Industrial Estate  
Revie Road, Beeston  
Leeds, LS11 8JG  
UK

email: [csuk@iconeurope.com](mailto:csuk@iconeurope.com)

### CAUTION

Read all precautions and instructions in this manual before using this equipment. Save this manual for future reference.



Visit our website at

[www.iconeurope.com](http://www.iconeurope.com)

# PRO-FORM 760 AIR

## CoolingBreeze

### TABLE OF CONTENTS

IMPORTANT PRECAUTIONS .....	3
BEFORE YOU BEGIN .....	5
ASSEMBLY .....	6
HOW TO USE THE CHEST PULSE SENSOR .....	9
OPERATION AND ADJUSTMENT .....	10
HOW TO FOLD AND MOVE THE TREADMILL .....	24
TROUBLESHOOTING .....	26
CONDITIONING GUIDELINES .....	29
PART LIST .....	30
ORDERING REPLACEMENT PARTS .....	Back Cover

Note: An EXPLODED DRAWING is attached in the centre of this manual.

Key No.	Qty.	Description	Key No.	Qty.	Description
101	1	Console Base	126	1	Pulley Bolt
102	1	Console Back	127	1	Chest Pulse Sensor
103	6	Ground Screw/Choke Screw	128	1	Splitter
104	1	Key Clip	129	1	Pulse Receiver
105	1	Hood	130	1	Optic Disk
106	1	Fan	131	1	Motor Isolator
107	1	Console	132	1	Controller Bracket
108	44	Screw	133	1	On/Off Switch
109	1	Left Tray	134	1	Circuit Breaker
110	1	CD Holder	#	1	8" Green Wire, F/Ring
111	1	Right Tray	#	1	8" Green Wire, 2 Ring
112	1	iFIT.com Wire	#	1	4" Green Wire, F/Ring
113	1	iFIT.com Jack	#	1	4" Blue Wire, 2F
114	2	Motor Bracket Bolt	#	1	8" White Wire, 2F
115	1	Photo Switch Screw	#	1	4" Black Wire, 2F
116	1	Access Door	#	1	6" Green Wire, F/Ring
117	1	Left Handgrip (Top)	#	1	10" Blue Wire, 2F
118	1	Photo Switch Nut	#	1	10" White Wire, 2F
119	1	Left Bottom Handgrip	#	1	User's Manual
120	1	Right Handgrip (Top)			
121	1	Right Bottom Handgrip			
122	1	Pulley Nut			
123	1	Chest Pulse Strap			
124	1	Idler Pulley			
125	1	Latch Assembly			

\* Includes all parts shown in the box

#These parts are not illustrated

Specifications are subject to change without notice.

# PART LIST—Model No. PETL75133

R0504A

To locate the parts listed below, see the EXPLODED DRAWING attached in the centre of this manual.

Key No.	Qty.	Description	Key No.	Qty.	Description
1	1	Left Foot Rail	51	2	Static Decal
2	12	Foot Rail Screw	52	10	3/4" Tek Screw
3	2	Isolator Bolt (Top)	53	3	Belly Pan Clip
4	2	Isolator Decal	54	1	Belly Pan
5	2	Isolator Top Cap	55	1	Releasable Tie
6	2	Isolator Spring	56	1	Latch Pin Collar
7	2	Isolator	57	1	Tie Holder Clamp
8	2	Isolator Bottom Cap	58	1	Cable Tie
9	2	Isolator Bracket Cover	59	1	Frame
10	2	Isolator Bracket	60	1	Right Rear Foot
11	4	Isolator Bracket Bolt	61	1	Idler Arm Washer
12	2	Isolator Bolt	62	2	Rear Roller Adj. Bolt
13	1	Walking Platform	63	1	Rear Roller
14	2	Belt Guide	64	1	Hex Key
15	4	Belt Guide Screw	65	1	5/32" Hex Key
16	2	Walking Platform Screw (Rear)	66	1	Left Rear Foot
17	2	Frame Pivot Bolt	67	1	Right Foot Rail
18	1	Front Roller/Pulley	68	1	Walking Belt
19	1	Magnet	69	2	Warning Decal
20	9	Pivot Nut	70	1	Photo Switch Star Washer
21	2	Pivot Bushing	71	1	Pulse Bar
22	1	Reed Switch	72	2	Motor Bushing
23	1	Reed Switch Screw	73	1	Console Top
24	1	Reed Switch Clip	74	1	Wire Harness
25	1	E-Clip	75	2	Top Endcap
26	1	Motor Tension Washer	76	4	Console Bolt
27	1	Audio Wire	77	4	Internal Star Washer
28	1	Motor Belt	78	1	Photo Switch Wire
29*	1	Idler Arm Assembly	79	2	Latch Screw
30	1	Idler Pivot Bolt	80	2	1" Tek Screw
31	1	Motor	81	1	Filter Wire
32	1	Idler Arm	82	1	Latch Housing
33	1	Lift Frame	83	1	Controller Wire
34	1	Spring	84	1	Latch Pin
35	2	Walking Platform Nut	85	1	Filter
36	1	Idler Arm Spring	86	2	Front Isolator Screw
37	1	Incline Motor	87	2	Front Isolator
38	2	Incline Motor Bolt	88	1	Latch Knob
39	6	1/4" Washer	89*	2	Extension Leg Assembly
40	2	Motor Bushing	90	2	Wheel Bolt
41	1	Front Roller Adj. Bolt	91	2	Warning Decal
42	2	Walking Platform Screw (Front)	92	2	Extension Leg
43	1	Transformer	93	1	Small Nut
44	1	Audio Wire	94	2	Wheel
45	1	Left Handrail	95	2	Leveling Foot
46	1	Right Handrail	96	4	Extension Leg Bolt
47	1	Chest Pulse Strap	97	1	Upright
48	1	Controller	98	1	Photo Switch
49	1	Power Cord	99	2	Base Pad
50	1	Receptical	100	2	Upright Base Endcap

# IMPORTANT PRECAUTIONS

**⚠ WARNING:** To reduce the risk of burns, fire, electric shock, or injury to persons, read the following important precautions and information before operating the treadmill.

- It is the responsibility of the owner to ensure that all users of this treadmill are adequately informed of all warnings and precautions.
- Use the treadmill only as described.
- Place the treadmill on a level surface, with at least 2.5 m (8 ft.) of clearance behind it and 0.5 m (2 ft.) on each side. Do not place the treadmill on any surface that blocks air openings. To protect the floor or carpet from damage, place a mat under the treadmill.
- Keep the treadmill indoors, away from moisture and dust. Do not put the treadmill in a garage or covered patio, or near water.
- Do not operate the treadmill where aerosol products are used or where oxygen is being administered.
- Keep children under the age of 12 and pets away from the treadmill at all times.
- The treadmill should be used only by persons weighing 115 kg (250 lbs.) or less.
- Never allow more than one person on the treadmill at a time.
- Wear appropriate exercise clothes when using the treadmill. Do not wear loose clothes that could become caught in the treadmill. Athletic support clothes are recommended for both men and women. *Always wear athletic shoes. Never use the treadmill with bare feet, wearing only stockings, or in sandals.*
- When connecting the power cord (see page 10), plug the power cord into an earthed circuit. No other appliance should be on the same circuit. When replacing the fuse, an ASTA approved BS1362 type should be fitted to the fuse carrier. A 13 amp fuse should be used.
- If an extension cord is needed, use only a 3-conductor, 1mm<sup>2</sup> (14-gauge) cord that is no longer than 1.5 m (5 ft.).
- Keep the power cord away from heated surfaces.
- Never move the walking belt whilst the power is turned off. Do not operate the treadmill if the power cord or plug is damaged, or if the treadmill is not working properly. (See BEFORE YOU BEGIN on page 5 if the treadmill is not working properly.)
- Never start the treadmill whilst you are standing on the walking belt. Always hold the handrails whilst using the treadmill.
- The treadmill is capable of high speeds. Adjust the speed in small increments to avoid sudden jumps in speed.
- Never leave the treadmill unattended whilst it is running. Always remove the key, unplug the power cord, and move the on/off switch to the off position when the treadmill is not in use. (See the drawing on page 5 for the location of the on/off switch.)
- Do not attempt to raise, lower, or move the treadmill until it is properly assembled. (See ASSEMBLY on page 6, and HOW TO FOLD AND MOVE THE TREADMILL on page 24.) You must be able to safely lift 20 kg (45 lbs.) to raise, lower, or move the treadmill.
- When folding or moving the treadmill, make sure that the storage latch is fully closed.
- The pulse sensors are not medical devices. Various factors, including your movement, may affect the accuracy of heart rate readings. The sensors are intended only as exercise aids in determining heart rate trends in general.
- When using iFIT.com CDs and videos, an electronic "chirping" sound will alert you when the speed and/or incline of the treadmill is about to change. Always listen for the "chirp" and be prepared for speed and/or incline changes. In some instances, the speed and/or incline may change before the personal trainer describes the change.

21. When using iFIT.com CDs and videos, you can manually override the speed and incline settings at any time by pressing the speed and incline buttons. However, when the next “chirp” is heard, the speed and/or incline will change to the next settings of the CD or video program.
22. Remove iFIT.com CDs and videos from your CD player or VCR when you are not using them.
23. Inspect and properly tighten all parts of the treadmill regularly.
24. Never insert any object into any opening.

25. **DANGER:** Always unplug the power cord immediately after use, before cleaning the treadmill, and before performing the maintenance and adjustment procedures described in this manual. Never remove the motor hood unless instructed to do so by an authorised service representative. Servicing other than the procedures in this manual should be performed by an authorised service representative only.

26. This treadmill is intended for in-home use only. Do not use this treadmill in a commercial, rental, or institutional setting.

### SAVE THESE INSTRUCTIONS

**⚠ WARNING:** Before beginning this or any exercise program, consult your physician. This is especially important for persons over the age of 35 or persons with pre-existing health problems. Read all instructions before using. ICON assumes no responsibility for personal injury or property damage sustained by or through the use of this product.

The decals shown at the right have been placed on your treadmill. If a decal is missing or illegible, please call our Customer Service Department to order a free replacement decal (see ORDERING REPLACEMENT PARTS on the back cover of this manual). Apply the decal in the location shown.

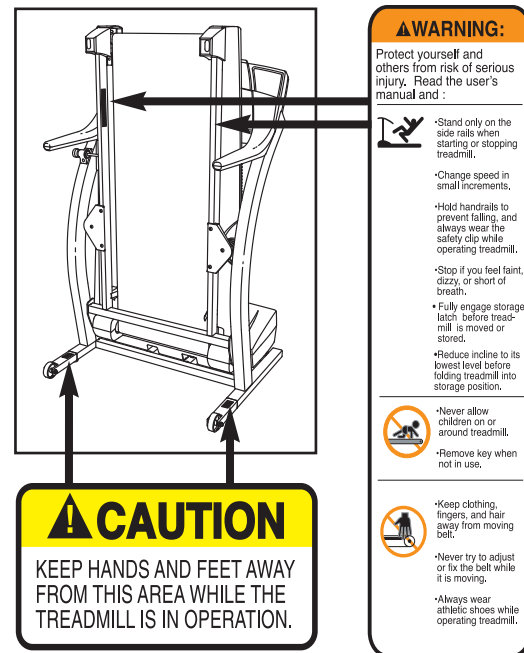

## CONDITIONING GUIDELINES

**⚠ WARNING:** Before beginning this or any exercise program, consult your physician. This is especially important for individuals over the age of 35 or individuals with pre-existing health problems.

The pulse sensors are not medical devices. Various factors, including your movement, may affect the accuracy of heart rate readings. The sensors are intended only as exercise aids in determining heart rate trends in general.

The following guidelines will help you to plan your exercise program. For more detailed exercise information, obtain a reputable book or consult your physician.

### EXERCISE INTENSITY

Whether your goal is to burn fat or to strengthen your cardiovascular system, the key to achieving the desired results is to exercise with the proper intensity. The proper intensity level can be found by using your heart rate as a guide. The chart below shows recommended heart rates for fat burning and aerobic exercise.

♥	165	155	145	140	130	125	115
♥	145	138	130	125	118	110	103
♥	125	120	115	110	105	95	90
	20	30	40	50	60	70	80

To find the proper heart rate for you, first find your age near the bottom of the chart (ages are rounded off to the nearest ten years). Next, find the three numbers above your age. The three numbers define your “training zone.” The lower two numbers are recommended heart rates for fat burning; the higher number is the recommended heart rate for aerobic exercise.

To measure your heart rate during exercise, use the pulse sensor.

### Fat Burning

To burn fat effectively, you must exercise at a relatively low intensity level for a sustained period of time. During the first few minutes of exercise, your body uses easily accessible *carbohydrate calories* for energy. Only after the first few minutes does your body

begin to use stored *fat calories* for energy. If your goal is to burn fat, adjust the speed and incline of the treadmill until your heart rate is near the lowest number in your training zone.

For maximum fat burning, adjust the speed and incline of the treadmill until your heart rate is near the middle number in your training zone.

### Aerobic Exercise

If your goal is to strengthen your cardiovascular system, your exercise must be “aerobic.” Aerobic exercise is activity that requires large amounts of oxygen for prolonged periods of time. This increases the demand on the heart to pump blood to the muscles, and on the lungs to oxygenate the blood. For aerobic exercise, adjust the speed and incline of the treadmill until your heart rate is near the highest number in your training zone.

### WORKOUT GUIDELINES

Each workout should include the following three parts:

**A Warm-up**—Start each workout with 5 to 10 minutes of stretching and light exercise. A proper warm-up increases your body temperature, heart rate and circulation in preparation for exercise.

**Training Zone Exercise**—After warming up, increase the intensity of your exercise until your pulse is in your training zone for 20 to 60 minutes. (During the first few weeks of your exercise program, do not keep your pulse in your training zone for longer than 20 minutes.) Breathe regularly and deeply as you exercise—never hold your breath.

**A Cool-down**—Finish each workout with 5 to 10 minutes of stretching to cool down. This will increase the flexibility of your muscles and will help prevent post-exercise problems.

### EXERCISE FREQUENCY

To maintain or improve your condition, complete three workouts each week, with at least one day of rest between workouts. After a few months, you may complete up to five workouts each week if desired. The key to success is to make exercise a regular and enjoyable part of your everyday life.

**PROBLEM: The heart rate monitor does not function properly**

**SOLUTION:** a. If the heart rate monitor does not function properly, see CHEST PULSE SENSOR TROUBLE-SHOOTING on page 9.

b. If the heart rate monitor still does not function properly, the battery should be changed. To replace the battery, locate the battery cover on the back of the sensor unit. Insert a coin into the slot in the cover and turn the cover counterclockwise to the "open" position. Remove the cover.

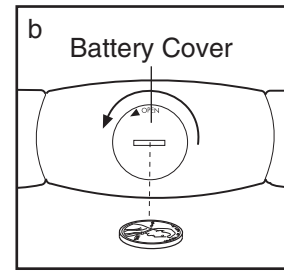

Remove the old battery from the sensor unit. Insert a new **CR 2032 battery**, making sure that the writing is on top. In addition, make sure that the rubber gasket is in place in the sensor unit. Replace the battery cover and turn it to the closed position.

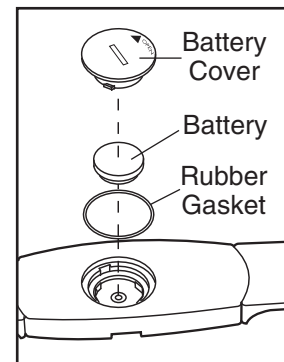

**PROBLEM: The incline of the treadmill does not change correctly**

**SOLUTION:** a. With the key in the console, press one of the Incline buttons. **Whilst the incline is changing, remove the key.** After a few seconds, reinsert the key. The treadmill will automatically rise to the maximum incline level and then return to the minimum level. This will recalibrate the incline system.

**PROBLEM: The treadmill rocks during use**

**SOLUTION:** a. See assembly step 6 on page 8.

## BEFORE YOU BEGIN

Thank you for selecting the revolutionary PROFORM® 760 AIR treadmill. The 760 AIR treadmill offers an impressive array of features to help you achieve your fitness goals in the convenience and privacy of your home. And when you're not exercising, the unique 760 AIR treadmill can be folded up, requiring less than half the floor space of other treadmills.

ing this manual, please call our Customer Service Department at 08457 089 009. To help us assist you, please note the product model number and serial number before calling. The model number of the treadmill is PETL75133. The serial number can be found on a decal attached to the treadmill (see the front cover of this manual for the location).

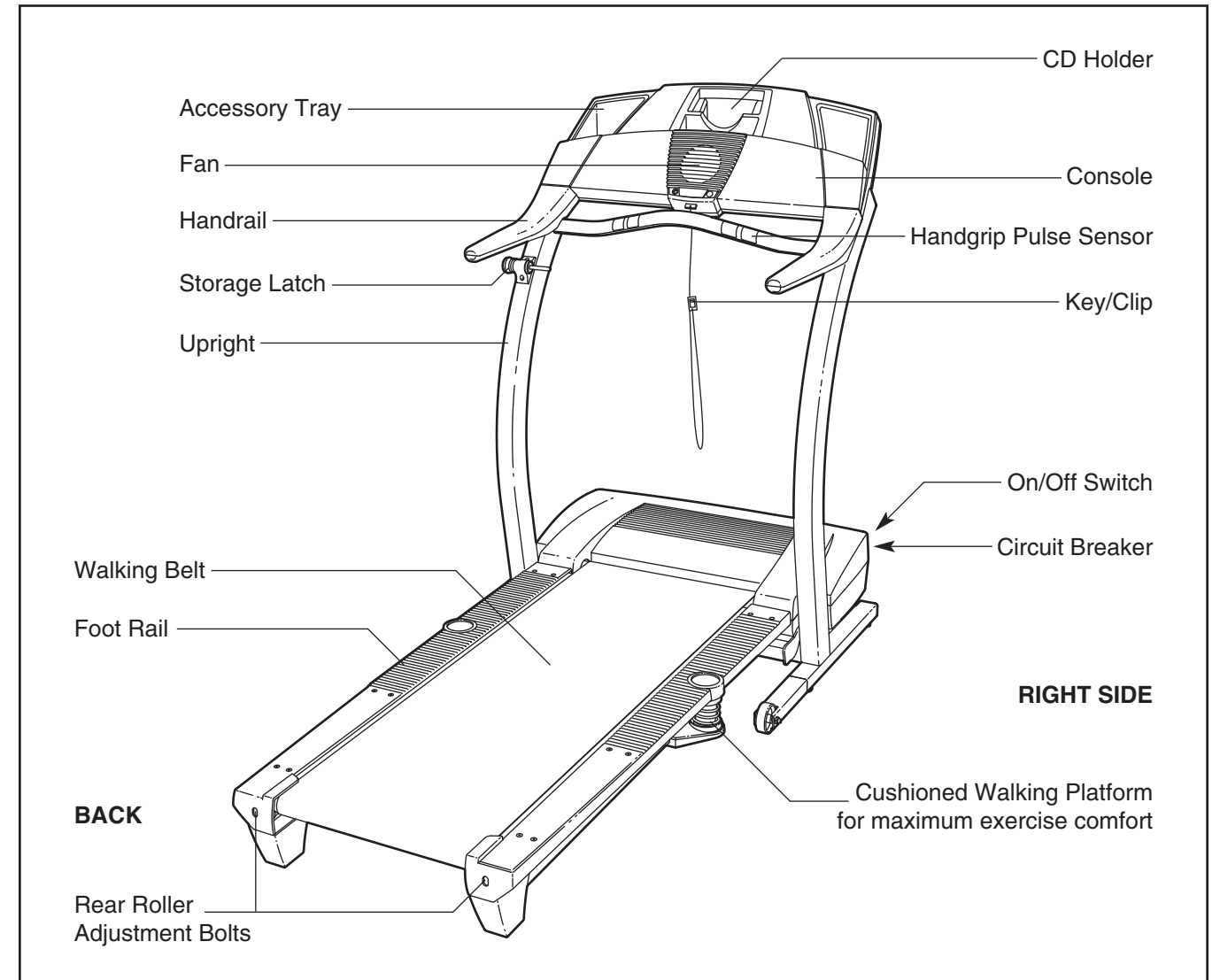

**For your benefit, read this manual carefully before using the treadmill.** If you have questions after read-

Before reading further, please review the drawing below and familiarise yourself with the labeled parts.



# ASSEMBLY

**Assembly requires two persons.** Set the treadmill in a cleared area and remove all packing materials. Do not dispose of the packing materials until assembly is completed. Note: The underside of the treadmill walking belt is coated with high-performance lubricant. During shipping, a small amount of lubricant may be transferred to the top of the walking belt or the shipping carton. This is a normal condition and does not affect treadmill performance. If there is lubricant on top of the walking belt, simply wipe off the lubricant with a soft cloth and a mild, non-abrasive cleaner.

**Assembly requires the included hex keys**  **and your own phillips screwdriver**  **and wire cutters** .

Use the drawings below to identify the assembly hardware. The number in parentheses below each drawing is the key number of the part, from the PART LIST on pages 30 and 31. The number after the parentheses shows the quantity needed for assembly. **Note: If a part is not in the parts bag, check to see if it is preattached to one of the parts to be assembled.**

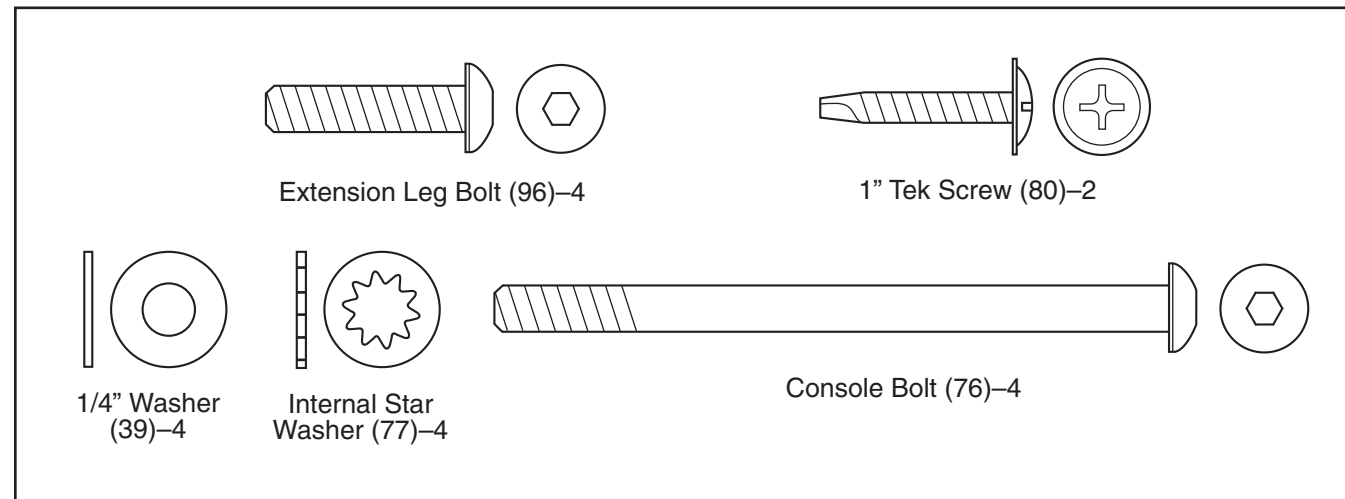

## 1. Make sure that the power cord is unplugged.

With the help of a second person, carefully raise the Uprights (97) to the position shown. Insert one of the Extension Legs (92) into the base of the right Upright. (Note: It may be helpful to tip the Uprights forward as you insert the Extension Leg.) Make sure that the Warning Decal (91) is in the indicated location.

Insert the other Extension Leg (not shown) in the same way.

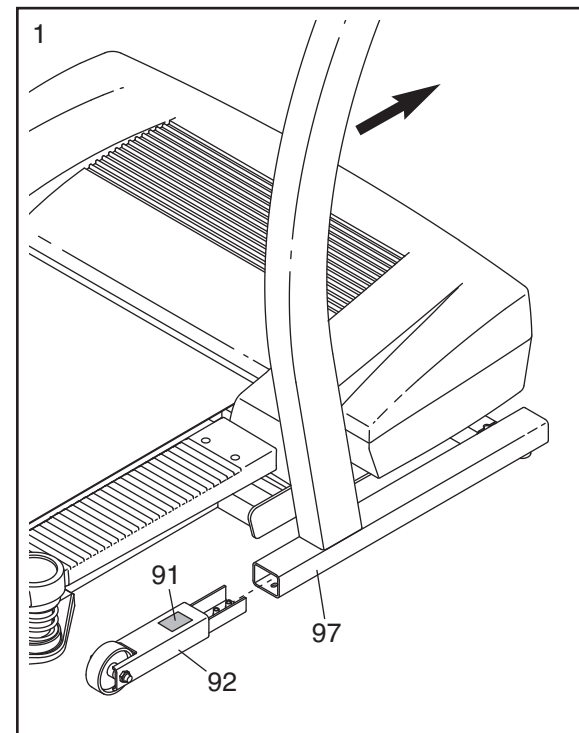

With the help of a second person, carefully raise the Upright Base (97) as shown. Carefully pivot the Hood (105) off.

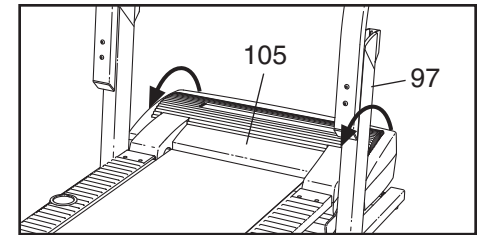

Locate the Reed Switch (22) and the Magnet (19) on the left side of the Pulley (18). Turn the Pulley until the Magnet is aligned with the Reed Switch. **Make sure that the gap between the Magnet and the Reed Switch is about 3 mm (1/8 in.).** If necessary, loosen the Screw (23) and move the Reed Switch slightly. Retighten the Screw. Reattach the Hood, and run the treadmill for a few minutes to check for a correct speed reading.

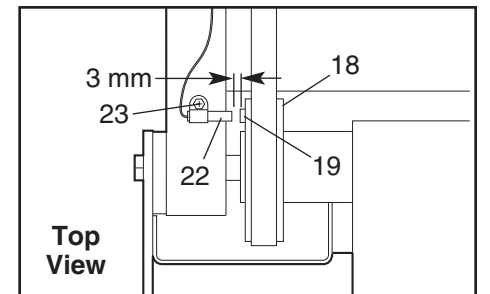

## PROBLEM: The walking belt slows when walked on

**SOLUTION:** a. If an extension cord is needed, use only a 3-conductor, 1mm<sup>2</sup> (14-gauge) cord that is no longer than 1.5 m (5 ft.).

b. If the walking belt is overtightened, treadmill performance may decrease and the walking belt may become damaged. Remove the key and **UNPLUG THE POWER CORD**. Using the hex key, turn both rear roller adjustment bolts counterclockwise, 1/4 of a turn. When the walking belt is properly tightened, you should be able to lift each side of the walking belt 5–7 cm (2–3 in.) off the walking platform. Be careful to keep the walking belt centred. Plug in the power cord, insert the key, and run the treadmill for a few minutes. Repeat until the walking belt is properly tightened.

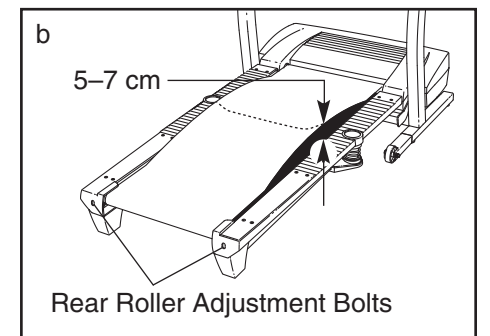

c. If the walking belt still slows when walked on, please call our Customer Service Department.

## PROBLEM: The walking belt is off-centre or slips when walked on

**SOLUTION:** a. **If the walking belt is off-centre**, first remove the key and **UNPLUG THE POWER CORD**. **If the walking belt has shifted to the left**, use the hex key to turn the left rear roller bolt clockwise 1/2 of a turn; **if the walking belt has shifted to the right**, turn the bolt counterclockwise 1/2 of a turn. Be careful not to overtighten the walking belt. Plug in the power cord, insert the key, and run the treadmill for a few minutes. Repeat until the walking belt is centred.

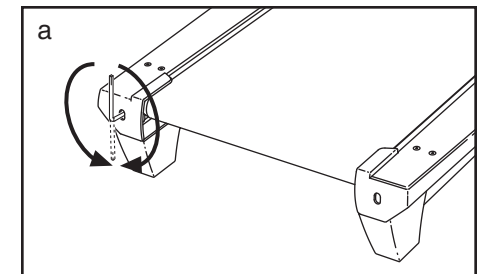

b. **If the walking belt slips when walked on**, first remove the key and **UNPLUG THE POWER CORD**. Using the hex key, turn both rear roller bolts clockwise, 1/4 of a turn. When the walking belt is correctly tightened, you should be able to lift each side of the walking belt 5–7 cm (2–3 in.) off the walking platform. Be careful to keep the walking belt centred. Plug in the power cord, insert the key, and carefully walk on the treadmill for a few minutes. Repeat until the walking belt is properly tightened.

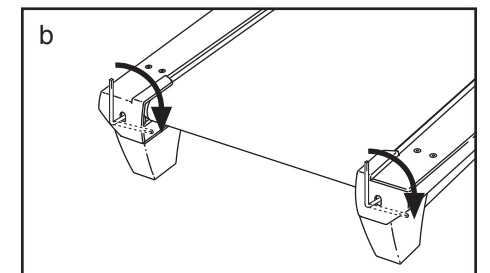

# TROUBLESHOOTING

Most treadmill problems can be solved by following the steps below. Find the symptom that applies, and follow the steps listed. If further assistance is needed, please call our Customer Service Department.

## PROBLEM: The power does not turn on

**SOLUTION:** a. Make sure that the power cord is plugged into a properly earthed outlet. (See page 10.) If an extension cord is needed, use only a 3-conductor, 1 mm<sup>2</sup> (14-gauge) cord that is no longer than 1.5 m (5 ft.). Important: The treadmill is not compatible with GFCI-equipped outlets.

b. After the power cord has been plugged in, make sure that the key is fully inserted into the console.

c. Check the circuit breaker located on the treadmill near the power cord. If the switch protrudes as shown, the circuit breaker has tripped. To reset the circuit breaker, wait for five minutes and then press the switch back in.

d. Check the on/off switch located on the treadmill near the power cord. The switch must be in the on position.

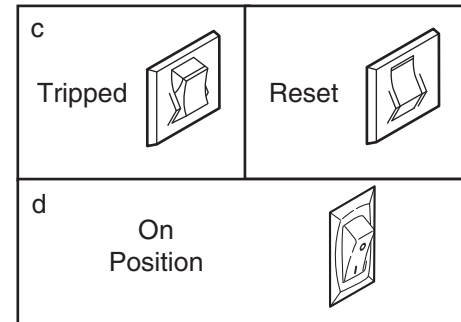

## PROBLEM: The power turns off during use

**SOLUTION:** a. Check the circuit breaker located on the treadmill frame near the power cord (see c. above). If the circuit breaker has tripped, wait for five minutes and then press the switch back in.

b. Make sure that the power cord is plugged in. If the power cord is plugged in, unplug it, wait for five minutes, and then plug it back in.

c. Remove the key from the console. Reinsert the key fully into the console.

d. Make sure that the on/off switch is in the on position.

e. If the treadmill still will not run, please call our Customer Service Department.

## PROBLEM: The displays of the console do not function properly

**SOLUTION:** a. Remove the key from the console and **UNPLUG THE POWER CORD**. With the help of a second person, carefully tip the Uprights (97) down as shown. Remove the five Screws (108). Note: A phillips screwdriver with at least a 127 mm (5 in.) shaft is required.

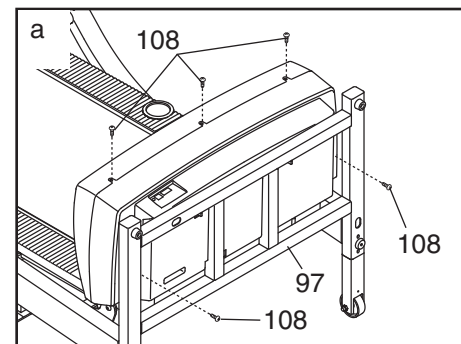

2. With the help of a second person, carefully tip the Uprights (97) down as shown. (Note: It may be helpful to place your foot on one of the Extension Legs [92] as you tip the Uprights.) **Make sure that the Extension Legs remain in the Uprights.**

Attach each Extension Leg (92) with two Extension Leg Bolts (96) and two 1/4" Washers (39) as shown. Thread a Leveling Foot (95) into the base of each Upright (97); **do not thread the Leveling Feet fully into the Uprights.**

Attach the two Base Pads (99) to the Uprights (97) in the locations shown with two 1" Tek Screws (80).

With the help of a second person, raise the Uprights (97) to the vertical position.

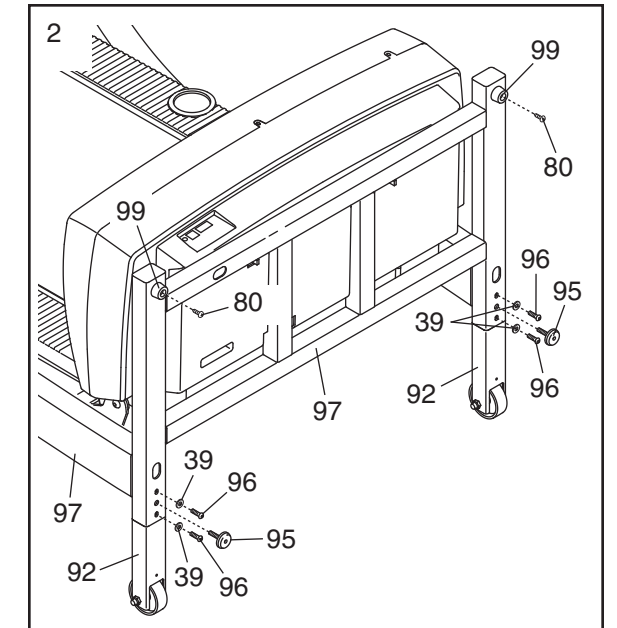

3. Remove the Latch Knob (88) from the Latch Pin (84). Make sure that the Latch Pin Collar (56) and the Spring (34) are on the Latch Pin. (Note: If there are two Latch Pin Collars, place one on each side of the Spring.) Insert the Latch Pin into the Latch Housing (82) and tighten the Latch Knob onto the Latch Pin.

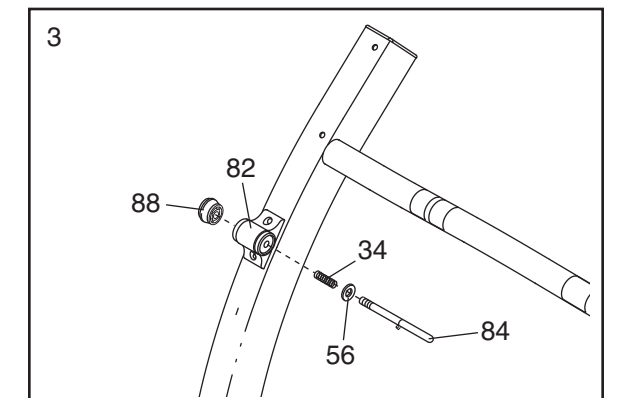

4. See drawing 4c. With the help of a second person, hold the Console Base (101) near the Uprights (97). Look under the Console Base and locate the wires on the sides of the Console Base. Make sure that the wires are **not** routed through the openings for the Trays (109, 111). Drawing 4a shows the correct route for the wires. Drawing 4b shows an incorrect route.

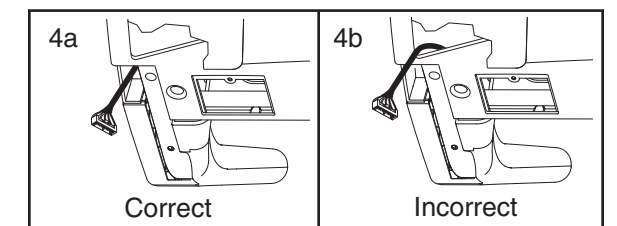

See drawing 4c. Cut the plastic ties holding the Wire Harness (74) and the pulse wire in the Uprights (97). Connect the Wire Harness and the pulse wire to the connectors on the sides of the Console Base (101). **Make sure to connect the connectors properly (see the inset drawings). IF THE CONNECTORS ARE NOT CONNECTED PROPERLY, THE CONSOLE MAY BE DAMAGED WHEN THE POWER IS TURNED ON. The connectors should slide together easily and snap into place.** If the connectors do not slide together easily and snap into place, turn a connector and then try to insert it. Insert the excess Wire Harness and pulse wire into the Console Base.

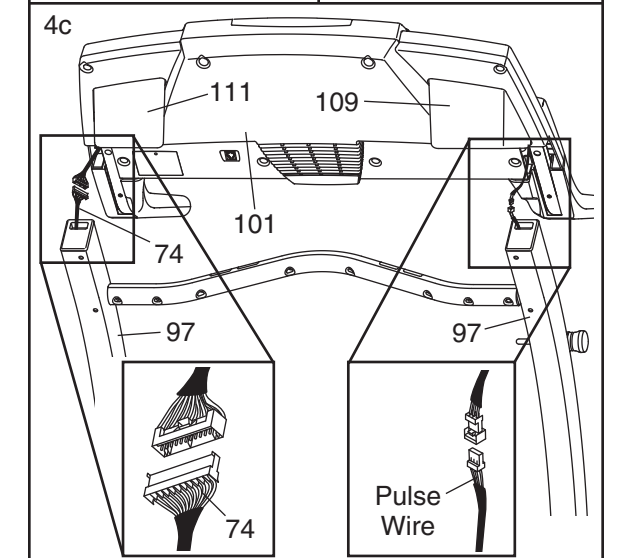

5. Set the Console Base (101) on the Uprights (97). Thread the four Console Bolts (76) with four Internal Star Washers (77) into the Uprights and the Console Base. **Be careful not to pinch the Wires (not shown) in the Uprights.** Tighten the two Console Bolts indicated by the arrows first; then, tighten the remaining two Console Bolts.

Make sure that the Left and Right Trays (109, 111) are pressed into the Console Base (101).

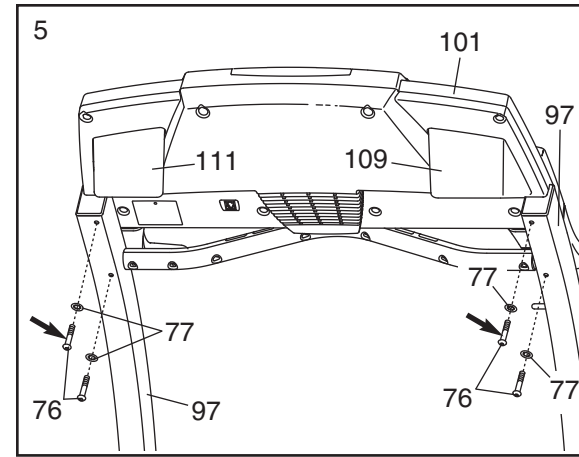

6. Fold the treadmill to the storage position (see page 24).

If the Wheels (94) are resting on the floor, or if the treadmill rocks slightly, turn one or both of the Leveling Feet (95) under the Uprights (97) until the Wheels are off the floor and the rocking motion is eliminated. Note: If necessary, tip the treadmill and use a phillips screwdriver to turn the Leveling Feet.

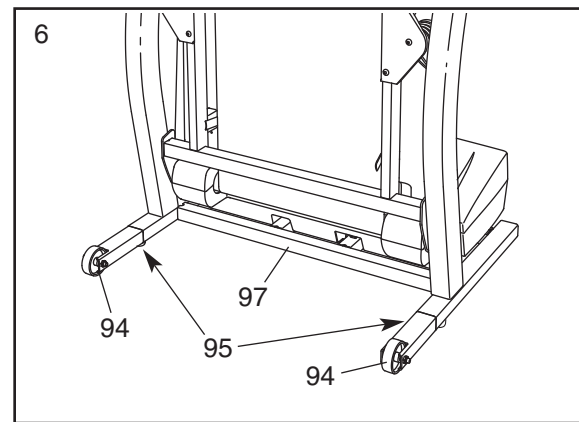

7. **Make sure that all parts are properly tightened before you use the treadmill.** Note: Extra hardware may be included. Keep the included hex keys in a secure place. The large hex key is used to adjust the walking belt (see page 27). To protect the floor or carpet, place a mat under the treadmill. If there are thin sheets of clear plastic on the decals, remove them.

#### HOW TO LOWER THE TREADMILL FOR USE

1. Hold the upper end of the treadmill with your right hand as shown. Using your left hand, pull the latch knob to the left and hold it. Pivot the treadmill down until the frame is past the latch pin. Slowly release the latch knob.

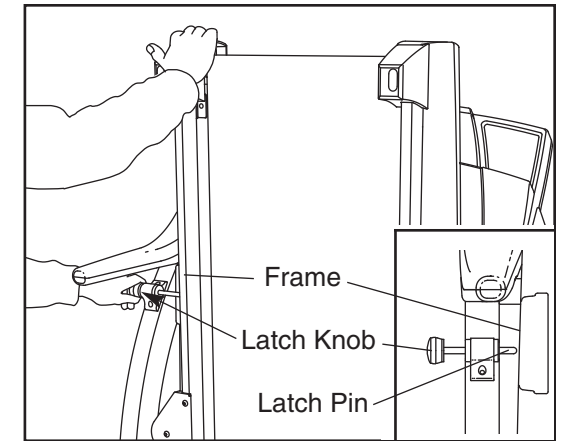

2. Hold the treadmill firmly with both hands, and lower the treadmill to the floor. **Do not drop the treadmill frame to the floor. To decrease the possibility of injury, bend your legs and keep your back straight.**

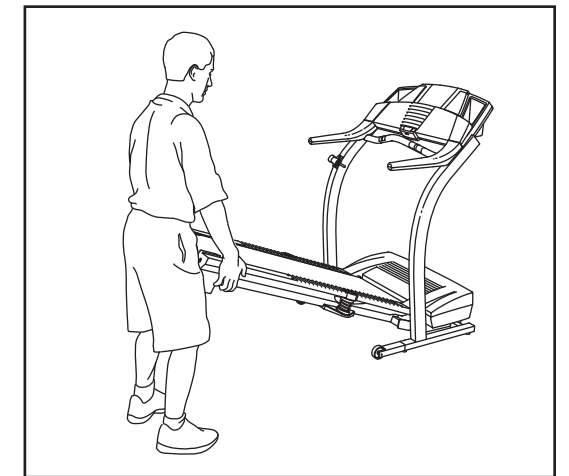



## HOW TO FOLD AND MOVE THE TREADMILL

### HOW TO FOLD THE TREADMILL FOR STORAGE

Before folding the treadmill, adjust the incline to the lowest position. If this is not done, the treadmill may be permanently damaged. Next, unplug the power cord. **CAUTION: You must be able to safely lift 20 kg (45 lbs.) to raise, lower, or move the treadmill.**

1. Hold the treadmill with your hands in the locations shown at the right. **To decrease the possibility of injury, bend your legs and keep your back straight. As you raise the treadmill, make sure to lift with your legs rather than your back.** Raise the treadmill about halfway to the vertical position.

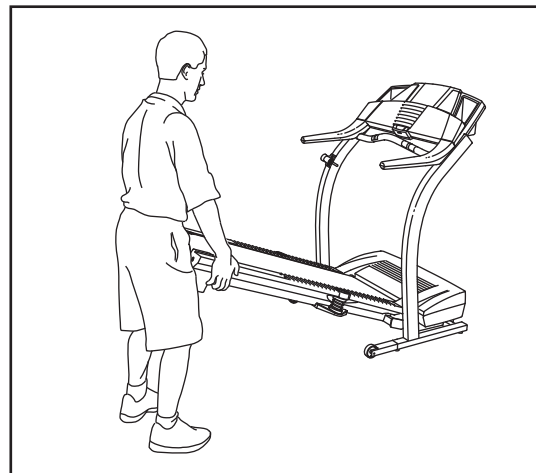

2. Move your right hand to the position shown and hold the treadmill firmly. Using your left hand, pull the latch knob to the left and hold it. Raise the treadmill until the frame is past the latch pin. Slowly release the latch knob. **Make sure that the frame is securely held by the latch pin.**

**To protect the floor or carpet from damage, place a mat under the treadmill. Keep the treadmill out of direct sunlight. Do not leave the treadmill in the storage position in temperatures above 30° C (85° F).**

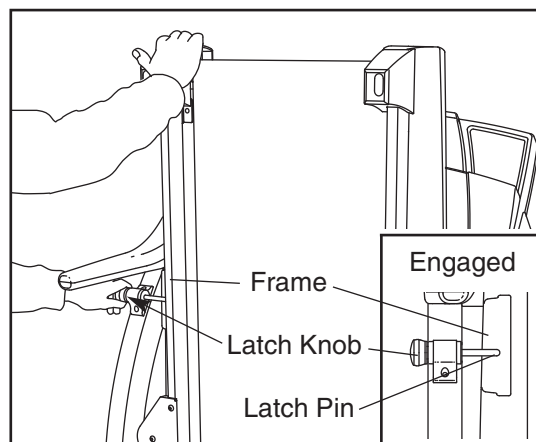

### HOW TO MOVE THE TREADMILL

Before moving the treadmill, convert the treadmill to the storage position as described above. **Make sure that the frame is securely held by the latch pin.**

1. Hold the upper ends of the handrails. Place one foot on the base as shown.
2. Tilt the treadmill back until it rolls freely on the front wheels. Carefully move the treadmill to the desired location. **To reduce the risk of injury, use extreme caution whilst moving the treadmill. Do not move the treadmill over an uneven surface.**
3. Place one foot on the base, and carefully lower the treadmill until it is resting in the storage position.

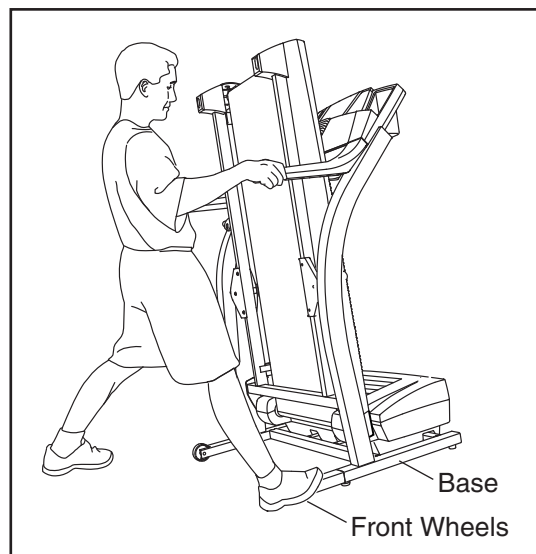

## HOW TO USE THE CHEST PULSE SENSOR

### HOW TO PUT ON THE CHEST PULSE SENSOR

The chest pulse sensor consists of two components: the chest strap and the sensor unit (see the drawing below). Insert the tab on one end of the chest strap into one end of the sensor unit, as shown in the inset drawing. Press the end of the sensor unit under the buckle on the chest strap. The tab should be flush with the front of the sensor unit.

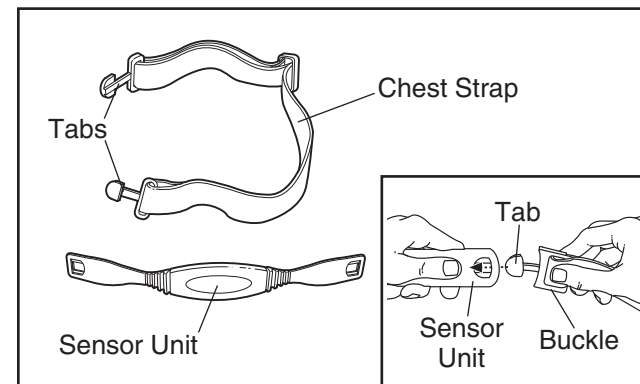

Next, wrap the chest pulse sensor around your chest and attach the other end of the chest strap to the sensor unit. Adjust the length of the chest strap, if necessary. The chest pulse sensor should be under your clothes, tight against your skin, and as high under the pectoral muscles or breasts as is comfortable. Make sure that the logo on the sensor unit is facing forward and is right-side-up.

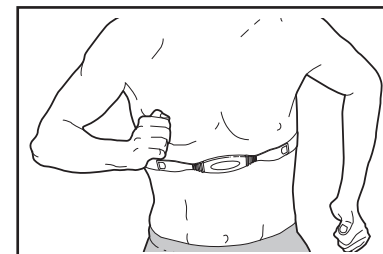

Pull the sensor unit away from your body a few inches and locate the two electrode areas on the inner side (the electrode areas are covered by shallow ridges). Using saline solution such as saliva or contact lens solution, wet both electrode areas. Return the sensor unit to a position against your chest.

### CHEST PULSE SENSOR CARE AND MAINTENANCE

- Thoroughly dry the chest pulse sensor after each use. The chest pulse sensor is activated when the electrode areas are wetted and the heart rate monitor is put on; the chest pulse sensor shuts off when it is removed and the electrode areas are dried. If the chest pulse sensor is not dried after

each use, it may remain activated longer than necessary, draining the battery prematurely.

- Store the chest pulse sensor in a warm, dry place. Do not store the chest pulse sensor in a plastic bag or other container that may trap moisture.
- Do not expose the chest pulse sensor to direct sunlight for extended periods of time; do not expose it to temperatures above 50° C (122° F) or below -10° C (14° F).
- Do not excessively bend or stretch the sensor unit when using or storing the chest pulse sensor.
- Clean the sensor unit using a damp cloth—never use alcohol, abrasives, or chemicals. The chest strap may be hand washed and air dried.

### CHEST PULSE SENSOR TROUBLESHOOTING

The instructions on the following pages explain how the chest pulse sensor is used with the console. If the chest pulse sensor does not function properly, try the steps below.

- Make sure that you are wearing the chest pulse sensor as described at the left. Note: If the chest pulse sensor does not function when positioned as described, move it slightly lower or higher on your chest.
- Use saline solution such as saliva or contact lens solution to wet the two electrode areas on the sensor unit. If heart rate readings do not appear until you begin perspiring, rewet the electrode areas.
- As you walk or run on the treadmill, position yourself near the centre of the walking belt. **For the console to display heart rate readings, the user must be within arm's length of the console.**
- The chest pulse sensor is designed to work with people who have normal heart rhythms. Heart rate reading problems may be caused by medical conditions such as premature ventricular contractions (pvc's), tachycardia bursts, and arrhythmia.
- The operation of the chest pulse sensor can be affected by magnetic interference caused by high power lines or other sources. If it is suspected that this is a problem, try relocating the treadmill.
- The CR2032 battery may need to be replaced (see page 28).

# OPERATION AND ADJUSTMENT

## THE PERFORMANT LUBE™ WALKING BELT

Your treadmill features a walking belt coated with PERFORMANT LUBE™, a high-performance lubricant. **IMPORTANT: Never apply silicone spray or other substances to the walking belt or the walking platform. Such substances will deteriorate the walking belt and cause excessive wear.**

## HOW TO PLUG IN THE POWER CORD

**This product must be earthed.** If it should malfunction or break down, earthing provides a path of least resistance for electric current to reduce the risk of electric shock. This product is equipped with a cord having an equipment-earthing conductor and an earthing plug. **Important: If the power cord is damaged, it must be replaced with a manufacturer-recommended power cord.**

Two power cords are included. Select the one that will fit your outlet. Refer to drawing 1. Plug the indicated end of the power cord into the socket on the treadmill.

Refer to drawing 2. Plug the power cord into an appropriate outlet that is properly installed and earthed in accordance with all local codes and ordinances. Note: In Italy, an adaptor (not included) must be used between the power cord and the outlet. **Important: The treadmill is not compatible with GFCI-equipped outlets.**

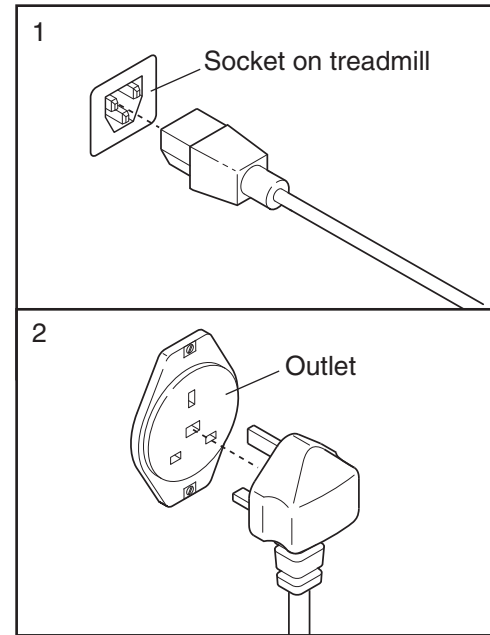

**⚠ DANGER:** Improper connection of the equipment-earthing conductor can result in an increased risk of electric shock. Check with a qualified electrician or serviceman if you are in doubt as to whether the product is properly earthed. Do not modify the plug provided with the product—if it will not fit the outlet, have a proper outlet installed by a qualified electrician.

## THE INFORMATION MODE/DEMO MODE

The console features an information mode that keeps track of the total number of hours that the treadmill has been used and the total number of miles that the walking belt has moved. The information mode also allows you to switch the console from miles per hour to kilometers per hour. In addition, the information mode allows you to turn on and turn off the demo mode.

To select the information mode, hold down the Stop button whilst inserting the key into the console. When the information mode is selected, the following information will be shown:

The Distance/Incline display will show the total number of miles (or kilometers) that the walking belt has moved.

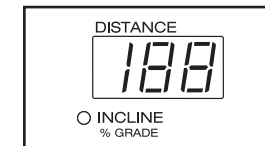

The Time/Pace display will show the total number of hours the treadmill has been used.



An "E" for English miles or an "M" for metric kilometers will appear in the Speed display. Press the Speed + button to change the unit of measurement.

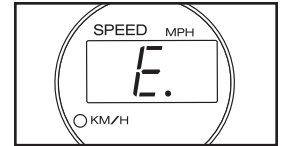

**IMPORTANT: The Calories/Pulse display should be blank.** If a "d" appears in the display, the console is in the "demo" mode. This mode is intended to be used only when a treadmill is displayed in a store. When the console is in the demo mode, the power cord can be plugged in, the key can be removed from the console, and the displays and indicators on the console will automatically light in a preset sequence, although the buttons on the console will not operate. **If a "d" appears in the Calories/Pulse display when the information mode is selected, press the Speed – button so the display is blank.**

To exit the information mode, remove the key from the console.

## HOW TO USE PROGRAMS DIRECTLY FROM OUR WEB SITE

To use programs from our Web site, the treadmill must be connected to your home computer. See HOW TO CONNECT YOUR COMPUTER on page 19. In addition, you must have an internet connection and an internet service provider. A list of specific system requirements is found on our Web site.

Follow the steps below to use a program from our Web site.

### 1 Insert the key into the console.

See HOW TO TURN ON THE POWER on page 12.

### 2 Select the iFIT.com mode.

When the key is inserted, the manual mode will be selected. To use a program from our Web site, press the iFIT.com button. The indicator on the button will light.

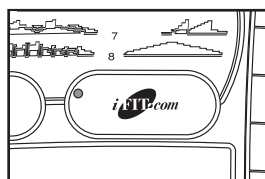

### 3 Go to your computer and start an internet connection.

### 4 Start your web browser, if necessary, and go to our Web site at www.iFIT.com.

### 5 Follow the desired links on our Web site to select a program.

Read and follow the on-line instructions for using a program.

### 6 Follow the on-line instructions to start the program.

When you start the program, an on-screen countdown will begin.

### 7 Return to the treadmill and stand on the foot pads. Find the clip attached to the key and slide the clip onto the waistband of your clothes.

When the on-screen countdown ends, the program will begin and the walking belt will begin to move. Hold the handrails, step onto the walking belt, and

begin walking. During the program, an electronic “chirping” sound will alert you when the speed and/or incline of the treadmill is about to change. **CAUTION: Always listen for the “chirp” and be prepared for speed and/or incline changes.**

If the speed or incline settings are too high or too low, you can manually override the settings at any time by pressing the Speed or Incline buttons on the console. **However, when the next “chirp” is heard, the speed and/or incline will change to the next settings of the program.**

To stop the walking belt at any time, press the Stop button on the console. The Time/Pace display will begin to flash. To restart the program, press the Start button or the Speed + button. After a moment, the walking belt will begin to move at 1 mph. **When the next “chirp” is heard, the speed and incline will change to the next settings of the program.**

When the program is completed, the walking belt will stop and the Time/Pace display will begin to flash. Note: To use another program, press the Stop button and go to step 5.

**Note: If the speed or incline of the treadmill does not change when a “chirp” is heard, make sure that the iFIT.com indicator is lit and that the Time/Pace display is not flashing. In addition, make sure that the audio cable is properly connected, that it is fully plugged in, and that it is not wrapped around a power cord.**

### 8 Follow your progress with the matrix and the displays.

See step 5 on page 12.

### 9 When you are finished exercising, remove the key from the console.

See step 7 on page 15.

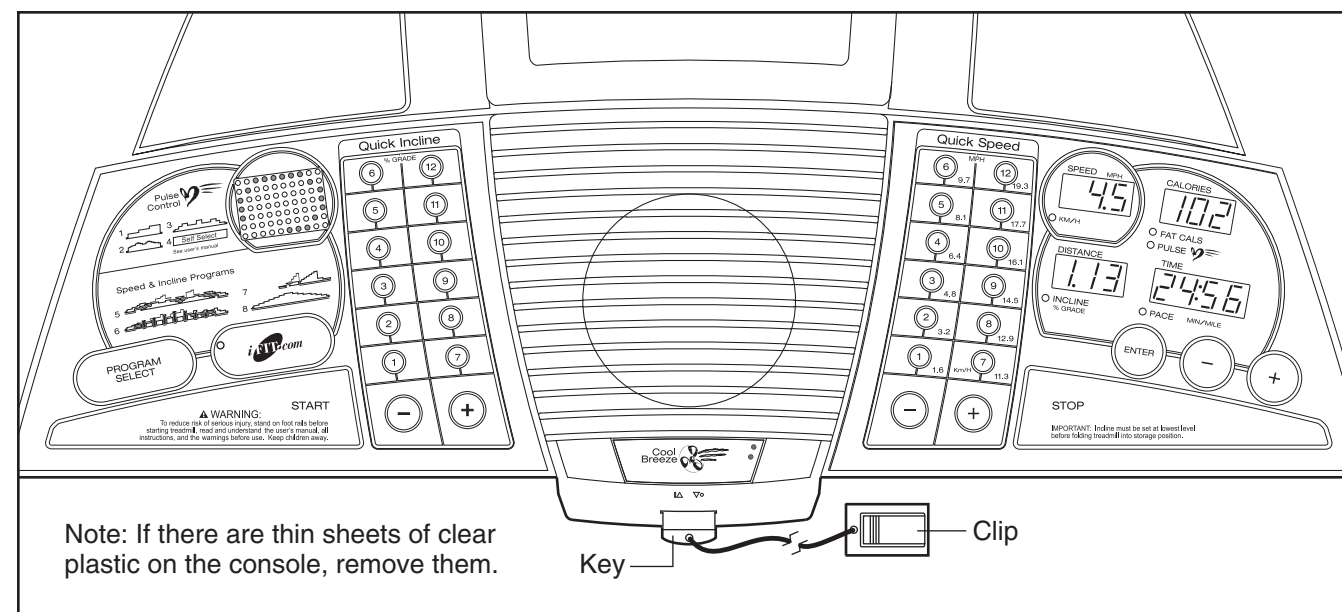

Note: If there are thin sheets of clear plastic on the console, remove them.

## FEATURES OF THE CONSOLE

The treadmill console offers an impressive array of features that help you get the most from your workouts.

When the manual mode of the console is selected, the speed and incline of the treadmill can be changed with the touch of a button. As you exercise, the console will display instant exercise feedback. You can even measure your heart rate using the handgrip pulse sensor or the chest pulse sensor.

In addition, the console offers four preset programs. Each program automatically controls the speed and incline of the treadmill as it guides you through an effective workout. Four pulse programs are also offered. Each program automatically adjusts the speed and incline of the treadmill to keep your heart rate near a target heart rate whilst you exercise.

The console also features iFIT.com interactive technology. Having iFIT.com technology is like having a personal trainer in your home. Using the included audio

cable, you can connect the treadmill to your home stereo, portable stereo, computer, or VCR and play special iFIT.com CD and video programs (iFIT.com CDs and videocassettes are available separately). iFIT.com CD and video programs automatically control the speed and incline of the treadmill as a personal trainer guides you through every step of your workout. High-energy music provides added motivation. **To purchase iFIT.com CDs or videocassettes, visit our Web site at www.iFIT.com.**

With the treadmill connected to your computer, you can also go to our Web site at www.iFIT.com and access programs directly from the internet. Additional options are soon to be available. **See www.iFIT.com for more information.**

**To use the manual mode of the console**, follow the steps beginning on page 12. **To use a preset program**, see page 14. **To use a pulse program**, see page 16. **To use an iFIT.com CD or video program**, see page 20. **To use iFIT.com programs directly from our Web site**, see page 22.

## HOW TO TURN ON THE POWER

**1** Plug in the power cord (see page 10).

**2** Locate the on/off switch on the treadmill near the power cord. Move the on/off switch to the on position.

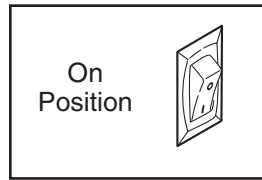

**3** Stand on the foot rails of the treadmill. Find the clip attached to the key (see the drawing on page 11) and slide the clip onto the waistband of your clothes. Next, route the cord attached to the clip **under the handgrip pulse sensor**, and insert the key into the console. After a moment, the displays and various indicators will light. **Test the clip by carefully taking a few steps backward until the key is pulled from the console. If the key is not pulled from the console, adjust the position of the clip.**

## HOW TO USE THE MANUAL MODE

**1** Insert the key fully into the console.

See HOW TO TURN ON THE POWER above.

**2** Select the manual mode.

When the key is inserted, the manual mode will be selected. If you have selected a program, select the manual mode by pressing the Program Select button repeatedly until a track appears in the matrix. Make sure that the indicator on the iFIT.com button is *not* lit.

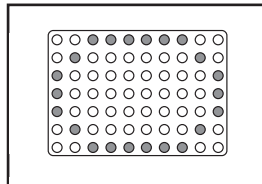

**3** Press the Start button or the Speed + button to start the walking belt.

A moment after the button is pressed, the walking belt will begin to move at 1 mph. Hold the handrails and begin

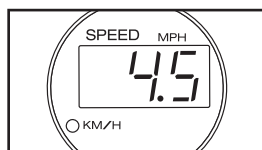

walking. As you exercise, change the speed of the walking belt as desired by pressing the Speed + and – buttons. Each time a button is pressed, the speed setting will change by 0.1 mph; if a button is held down, the speed setting will change in increments of 0.5 mph. To change the speed setting quickly, press the Quick Speed buttons. **Note: The console can display speed and distance in either miles or kilometers. For simplicity, all instructions in this section refer to miles.**

To stop the walking belt, press the Stop button. The Time/Pace display will begin to flash. To restart the walking belt, press the Start button or the Speed + button.

Note: The first time the treadmill is used, observe the alignment of the walking belt, and align the walking belt if necessary (see page 27).

**4** Change the incline of the treadmill as desired.

To change the incline of the treadmill, press the Incline + and – buttons. Each time a button is pressed, the incline will change by 0.5%. To change the incline setting quickly, press the Quick Incline buttons.

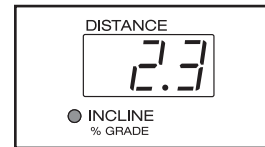

**5** Follow your progress with the matrix and the displays.

**The matrix**—When the manual mode or the iFIT.com mode is selected, the matrix will display a 1/4-mile track. As you exercise, the indicators around the track will light in succession until the entire track is lit. The track will then darken and the indicators will again begin to light in succession.

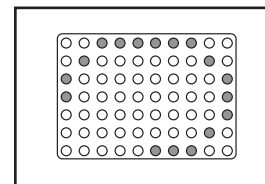

**Speed display**—This display shows the speed of the walking belt. Note: When the KM/H indicator is lit, the console will display speed and distance in kilometers; when the KM/H indicator is not lit, the console will display speed and distance in miles.

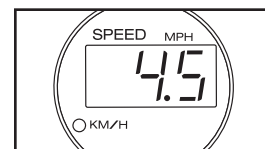

If the speed or incline settings are too high or too low, you can manually override the settings at any time by pressing the Speed or Incline buttons on the console. However, **when the next “chirp” is heard, the speed and/or incline will change to the next settings of the CD or video program.**

To stop the walking belt at any time, press the Stop button on the console. The Time/Pace display will begin to flash. To restart the program, press the Start button or the Speed + button. After a moment, the walking belt will begin to move at 1 mph. **When the next “chirp” is heard, the speed and incline will change to the next settings of the CD or video program.**

When the CD or video program is completed, the walking belt will stop and the Time/Pace display will begin to flash. Note: To use another CD or video program, press the Stop button or remove the key and go to step 1 on page 20.

**Note: If the speed or incline of the treadmill does not change when a “chirp” is heard:**

- Make sure that the iFIT.com indicator is lit and that the Time/Pace display is not flashing. If the Time/Pace display is flashing, press the Start button or the Speed + button on the console.

- Adjust the volume of your CD player or VCR. If the volume is too high or too low, the console may not detect the program signals.

- Make sure that the audio cable is properly connected, that it is fully plugged in, and that it is not wrapped around a power cord.

- If you are using your portable CD player and the CD skips, set the CD player on the floor or another flat surface instead of on the console.

**5** Follow your progress with the matrix and the displays.

See step 5 on page 12.

**6** Measure your heart rate if desired.

See step 6 on page 13.

**7** Turn on the fan if desired.

See step 7 on page 13.

**8** When you are finished exercising, remove the key from the console.

See step 7 on page 15.

**CAUTION: Always remove iFIT.com CDs and videocassettes from your CD player and VCR when you are finished using them.**

## HOW TO CONNECT YOUR VCR

**Note:** If your VCR has an unused AUDIO OUT jack, see instruction A below. If the AUDIO OUT jack is being used, see instruction B. If you have a TV with a built-in VCR, see instruction B. If your VCR is connected to your home stereo, see HOW TO CONNECT YOUR HOME STEREO on page 19.

- A. Plug one end of the audio cable into the jack on the front of the treadmill near the power cord. Plug the other end of the cable into the included adapter. Plug the adapter into the AUDIO OUT jack on your VCR.

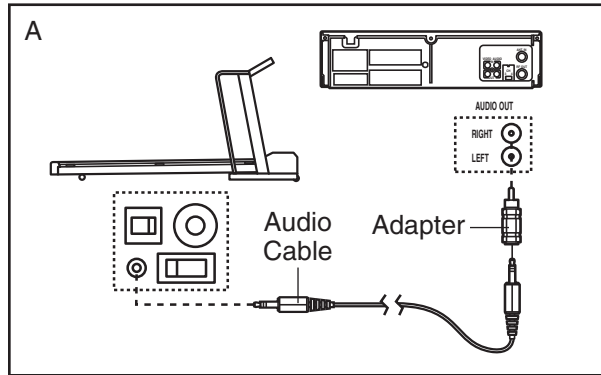

- B. Plug one end of the audio cable into the jack on the front of the treadmill near the power cord. Plug the other end of the cable into the included adapter. Plug the adapter into an RCA Y-adapter (available at electronics stores). Next, remove the wire that is currently plugged into the AUDIO OUT jack on your VCR and plug the wire into the unused side of the RCA Y-adapter. Plug the RCA Y-adapter into the AUDIO OUT jack on your VCR.

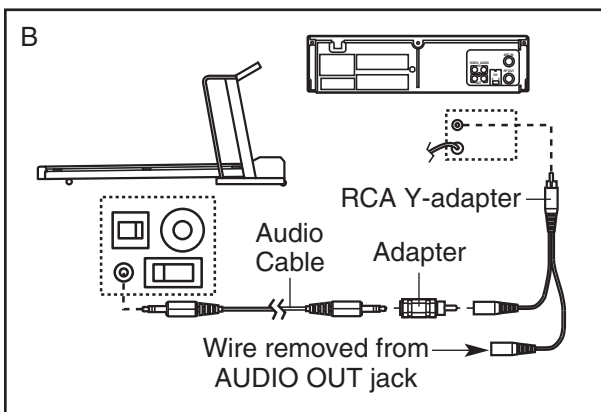

## HOW TO USE iFIT.COM CD AND VIDEO PROGRAMS

To use iFIT.com CDs or videocassettes, the treadmill must be connected to your portable CD player, portable stereo, home stereo, computer with CD player, or VCR. See HOW TO CONNECT THE TREADMILL TO YOUR CD PLAYER, VCR, OR COMPUTER on pages 18 to 20. **Note:** To purchase iFIT.com CDs or videocassettes, visit our Web site at [www.iFIT.com](http://www.iFIT.com).

Follow the steps below to use an iFIT.com CD or video program.

### 1 Insert the key into the console.

See HOW TO TURN ON THE POWER on page 12.

### 2 Select the iFIT.com mode.

When the key is inserted, the manual mode will be selected. To use iFIT.com CDs or videocassettes, press the iFIT.com button. The indicator on the button will light.

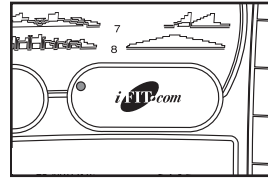

### 3 Insert the iFIT.com CD or videocassette.

If you are using an iFIT.com CD, insert the CD into your CD player. If you are using an iFIT.com videocassette, insert the videocassette into your VCR.

### 4 Press the PLAY button on your CD player or VCR.

A moment after the button is pressed, your personal trainer will begin guiding you through your workout. Simply follow your personal trainer's instructions. Note: If the Time/Pace display is flashing, press the Start button or the Speed + button on the console. The treadmill will not respond to a CD or video program whilst the Time/Pace display is flashing.

During the CD or video program, an electronic "chirping" sound will alert you when the speed and/or incline of the treadmill is about to change. **CAUTION: Always listen for the "chirp" and be prepared for speed and/or incline changes. In some instances, the speed and/or incline may change before the personal trainer describes the change.**

To change the unit of measurement, first hold down the Stop button whilst inserting the key into the console. An "E" for English miles or an "M" for metric kilometers will appear in the Speed display. Press the Speed + button to change the unit of measurement. When the desired unit of measurement is selected, remove the key.

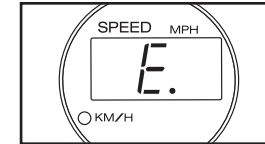

**Calories/Pulse display**—This display shows the approximate numbers of *calories* and *fat calories* you have burned (see FAT BURNING on page 29). The display will change from one number to the other every few seconds. The display will also show your heart rate when you use the handgrip pulse sensor or the chest pulse sensor.



**Distance/Incline display**—This display shows the distance that you have walked or run and the incline level of the treadmill. The display will change from one number to the other every few seconds. Note: Each time the incline changes, the display will show the incline setting for several seconds.

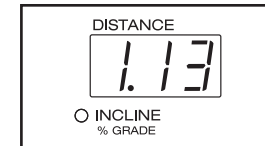

**Time/Pace display**—When the manual mode or the iFIT.com mode is selected, this display will show the elapsed time and your current pace (pace is measured in *minutes per mile*). The display will change from one number to the other every few seconds. When a program is selected (except for pulse program 4), the display will show the time *remaining* in the program rather than the elapsed time.



To reset the displays, press the Stop button, remove the key, and then reinsert the key.

## 6 Measure your heart rate if desired.

You can measure your heart rate using either the chest pulse sensor or the handgrip pulse sensor.

To use the handgrip pulse sensor, first make sure that your hands are clean. Next, **stand on the foot rails** and hold the handgrip pulse sensor with your palms on the metal contacts.

**Avoid moving your hands.** When your pulse is detected, two dashes (--) will appear in the Calories/Pulse display, and then your heart rate will be shown. **For the most accurate heart rate reading, continue to hold the contacts for about 15 seconds.**

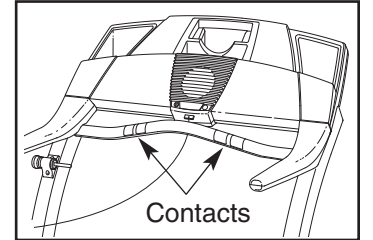

## 7 Turn on the fan if desired.

To turn on the fan, press the button below the fan. To turn on the fan at high speed, press the button a second time. To turn off the fan, press the button a third time. Note: A few minutes after the walking belt is stopped, the fan will automatically turn off.

## 8 When you are finished exercising, remove the key from the console.

Step onto the foot rails, press the Stop button, and **adjust the incline of the treadmill to the lowest setting. The incline must be at the lowest setting when the treadmill is folded to the storage position or the treadmill will be damaged.** Next, remove the key from the console and put it in a secure place. **Note: If the displays and various indicators on the console remain lit after the key is removed, the console is in the "demo" mode. See page 23 and turn off the demo mode.**

When you are finished using the treadmill, move the on/off switch near the power cord to the off position and unplug the power cord.

## HOW TO USE PRESET PROGRAMS

### 1 Insert the key fully into the console.

See HOW TO TURN ON THE POWER on page 12.

### 2 Select one of the preset programs.

When the key is inserted, the manual mode will be selected. To select a preset program, press the Program Select button repeatedly until a "P 5," "P 6," "P 7," or "P 8" appears in the Distance/Incline display.

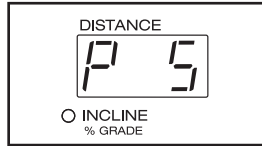

When a preset program is selected, the Speed display will flash the maximum speed setting of the program for a few seconds. The Time/Pace display will show how long the program will last.

The matrix will show the first seven speed settings of the program. Note: The diagrams numbered 5 through 8 on the left side of the console show how the speed and incline will change during the preset programs. For example, diagram number 8 shows that during preset program 8, the speed will gradually increase during the first half of the program and then gradually decrease during the last half; the incline will remain constant.

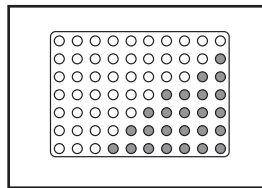

### 3 Press the Start button or the Speed + button to start the program.

A moment after the button is pressed, the treadmill will automatically adjust to the first speed and incline settings of the program. Hold the handrails and begin walking.

Each program is divided into several time segments of different lengths. One speed setting and one incline setting are programmed for each segment. Note: The same speed setting and/or incline setting may be programmed for two or more consecutive segments.

The speed setting for the first segment is shown in the flashing Current Segment column of the matrix. (The incline settings are not shown in the matrix.) The speed settings for the next seven segments are shown in the seven columns to the right.

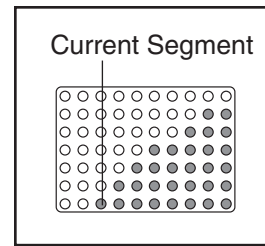

When only three seconds remain in the first segment of the program, both the Current Segment column and the column to the right will flash and a series of tones will sound. If the speed and/or incline of the treadmill is about to change, the Speed display and/or the Distance/Incline display will flash to alert you. When the first segment ends, *all speed settings will move one column to the left.* The speed setting for the second segment will then be shown in the flashing Current Segment column and the treadmill will automatically adjust to the speed and incline settings for the second segment. Note: If all of the indicators in the Current Segment column are lit after the speed settings have moved to the left, *the speed settings may move downward* so that only the highest indicators appear in the matrix. If some of the indicators in the Current Segment column are not lit when the speed settings move to the left again, the speed settings will move back up.

The program will continue in this way until the speed setting for the last segment is shown in the Current Segment column of the matrix and the last segment ends. The walking belt will then slow to a stop.

If the speed or incline setting is too high or too low at any time during the program, you can manually override the setting by pressing the Speed or Incline buttons. Every few times a Speed button is pressed, an additional indicator will light or darken in the Current Segment column. (If any of the columns to the right of the Current Segment column have the same number of lit indicators as the Current Segment column, an additional indicator may light or darken in those columns as well.) **Note: When the next segment of the program begins, the treadmill will automatically adjust to the speed and incline settings for the next segment.**

## HOW TO CONNECT YOUR HOME STEREO

**Note: If your stereo has an unused LINE OUT jack, see instruction A below. If the LINE OUT jack is being used, see instruction B.**

- A. Plug one end of the audio cable into the jack on the front of the treadmill near the power cord. Plug the other end of the cable into the adaptor. Plug the adaptor into the LINE OUT jack on your stereo.

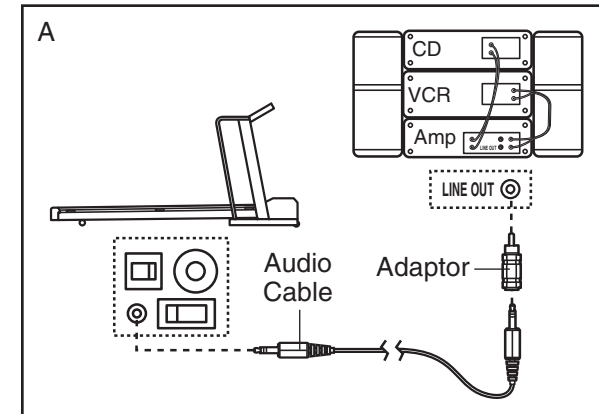

- B. Plug one end of the audio cable into the jack on the front of the treadmill near the power cord. Plug the other end of the cable into the adaptor. Plug the adaptor into an RCA Y-adaptor (available at electronics stores). Next, remove the wire that is currently plugged into the LINE OUT jack on your stereo and plug the wire into the unused side of the Y-adaptor. Plug the Y-adaptor into the LINE OUT jack on your stereo.

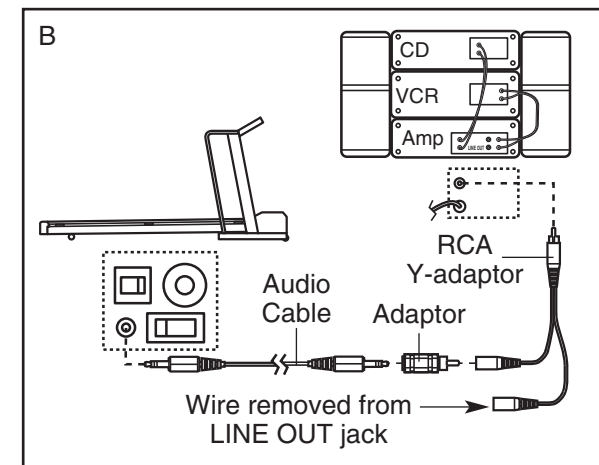

## HOW TO CONNECT YOUR COMPUTER

**Note: If your computer has a 3.5 mm LINE OUT jack, see instruction A. If your computer has only a PHONES jack, see instruction B.**

- A. Plug one end of the audio cable into the jack on the front of the treadmill near the power cord. Plug the other end of the cable into the LINE OUT jack on your computer.

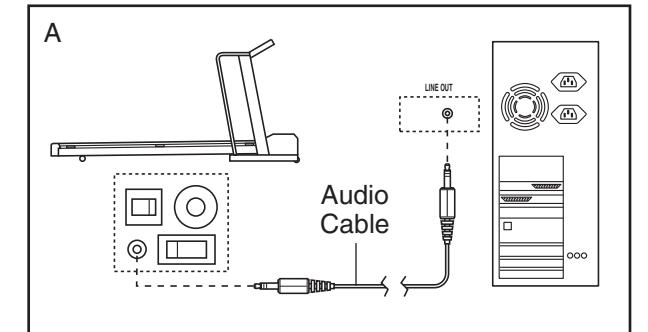

- B. Plug one end of the audio cable into the jack on the front of the treadmill near the power cord. Plug the other end of the cable into the splitter. Plug the splitter into the PHONES jack on your computer. Plug your headphones or speakers into the other side of the splitter.

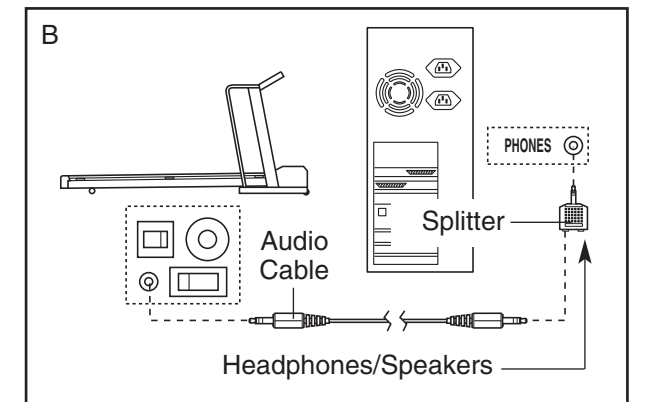

## HOW TO CONNECT THE TREADMILL TO YOUR CD PLAYER, VCR, OR COMPUTER

To use **iFIT.com CDs**, the treadmill must be connected to your portable CD player, portable stereo, home stereo, or computer with CD player. See pages 18 and 19 for connecting instructions. To use **iFIT.com video-cassettes**, the treadmill must be connected to your VCR. See page 20 for connecting instructions. To use **iFIT.com programs directly from our Web site**, the treadmill must be connected to your home computer. See page 19 for connecting instructions.

### HOW TO CONNECT YOUR PORTABLE CD PLAYER

**Note: If your CD player has separate LINE OUT and PHONES jacks, see instruction A below. If your CD player has only one jack, see instruction B.**

A. Plug one end of the audio cable into the jack on the front of the treadmill near the power cord. Plug the other end of the cable into the LINE OUT jack on your CD player. Plug your headphones into the PHONES jack.

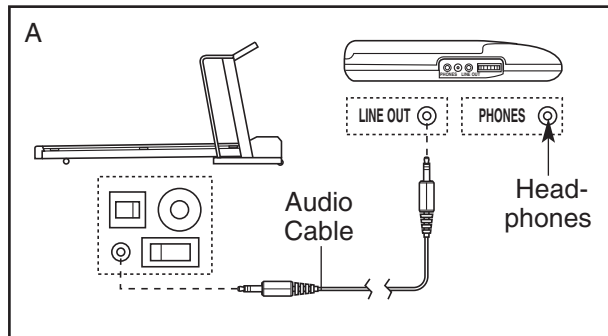

B. Plug one end of the audio cable into the jack on the front of the treadmill near the power cord. Plug the other end of the cable into the splitter. Plug the splitter into the PHONES jack on your CD player. Plug your headphones into the other side of the splitter.

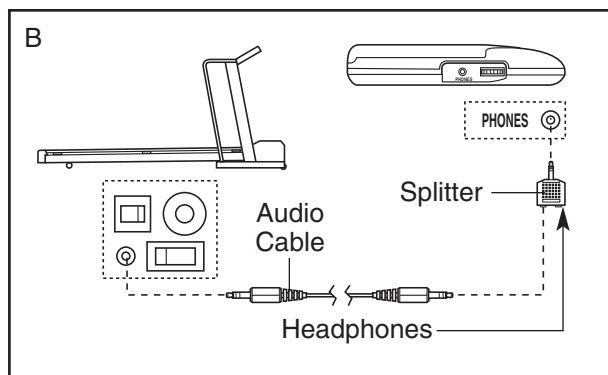

### HOW TO CONNECT YOUR PORTABLE STEREO

**Note: If your stereo has an RCA-type AUDIO OUT jack, see instruction A below. If your stereo has a 3.5 mm LINE OUT jack, see instruction B. If your stereo has only a PHONES jack, see instruction C.**

A. Plug one end of the audio cable into the jack on the front of the treadmill near the power cord. Plug the other end of the cable into the adaptor. Plug the adaptor into an AUDIO OUT jack on your stereo.

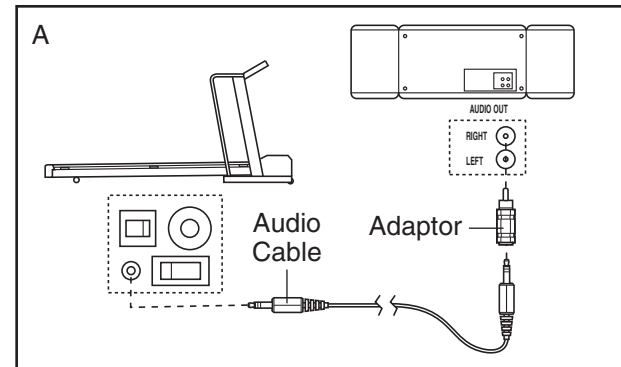

B. Plug one end of the audio cable into the jack on the front of the treadmill near the power cord. Plug the other end of the cable into the LINE OUT jack on your stereo.

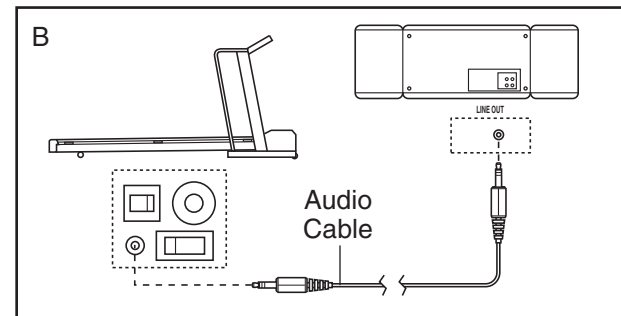

C. Plug one end of the audio cable into the jack on the front of the treadmill near the power cord. Plug the other end of the cable into the splitter. Plug the splitter into the PHONES jack on your stereo. Plug your headphones into the other side of the splitter.

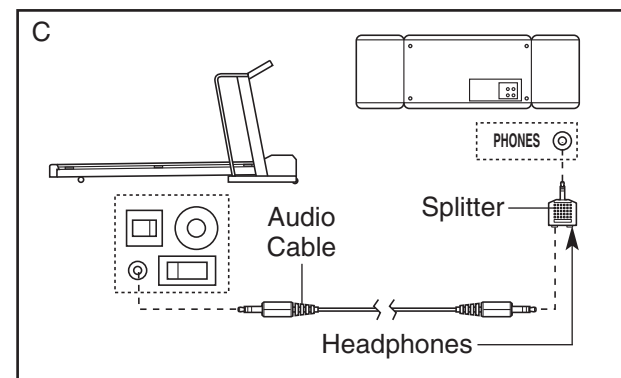

To stop the program at any time, press the Stop button. The Time/Pace display will begin to flash. To restart the program, press the Start button or the Speed + button. The walking belt will begin to move at 1 mph. When the next segment of the program begins, the treadmill will automatically adjust to the speed and incline settings for the next segment.

**4 Follow your progress with the displays.**

See step 5 on page 12.

**5 Measure your heart rate if desired.**

See step 6 on page 13.

**6 Turn on the fan if desired.**

See step 7 on page 13.

**7 When you are finished exercising, remove the key from the console.**

When the program has ended, **make sure that the incline of the treadmill is at the lowest setting.** Next, remove the key from the console and put it in a secure place. **Note: If the displays and various indicators on the console remain lit after the key is removed, the console is in the "demo" mode. See page 23 and turn off the demo mode.**

When you are finished using the treadmill, move the on/off switch near the power cord to the off position and unplug the power cord.

## HOW TO USE PULSE PROGRAMS

**CAUTION:** If you have heart problems, or if you are over 60 years of age and have been inactive, do not use the pulse programs. If you are taking medication regularly, consult your physician to find whether the medication will affect your exercise heart rate.

### 1 Put on the chest pulse sensor.

You must wear the chest pulse sensor to use a pulse program. See the instructions on page 9.

### 2 Insert the key fully into the console.

See HOW TO TURN ON THE POWER on page 12.

### 3 Select a pulse program.

When the key is inserted, the manual mode will be selected. To select a pulse program, press the Program Select button repeatedly until a “P 1,” “P 2,” “P 3,” or “P 4” appears in the Distance/Incline display.

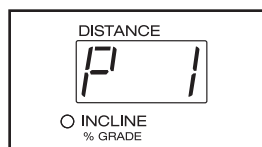

The diagrams numbered 1 through 4 on the left side of the console show how the target heart rate will change during the programs. During pulse program 1, your heart rate will reach approximately 85% of your *estimated maximum heart rate*; during pulse programs 2 and 3, your heart rate will reach approximately 80% of your estimated maximum heart rate; during pulse program 4, your heart rate will remain near a level that you select.

Note: Your estimated maximum heart rate is determined by subtracting your age from 220. For example, if you are 30 years old, your estimated maximum heart rate is 190 beats per minute (220 – 30 = 190).

During pulse programs, the matrix will show a moving graphic that represents your heart rate. Each time a heartbeat is detected, an additional peak will appear.

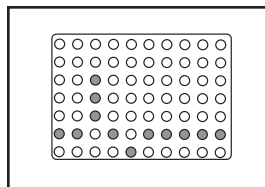

### 4 Enter your age.

When a pulse program is selected, the word “AGE” and the current age setting will flash in the Calories/Pulse display. If you have already entered your age, simply press the Enter button. If you have not entered your age, press the + and – buttons beside the Enter button to enter your age. Then, press the Enter button.



### 5 Enter a target heart rate.

If pulse program 1, 2, or 3 is selected, go to step 6. If pulse program 4 is selected, follow the instructions below.

After you have entered your age, the letters “PLS” and the target heart rate setting for the program will flash in the Calories/Pulse display. If desired, press the + and – buttons beside the Enter button to adjust the target heart rate setting. When the desired setting is shown, press the Enter button.



### 6 Enter a maximum speed.

Next, the letters “SPd” and the maximum speed setting of the program will flash in the Calories/Pulse display. If desired, press the + and – buttons beside the Enter button to adjust the maximum speed setting. When the desired setting is shown, press the Enter button.

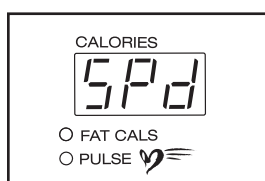

### 7 Press the Start button or the Speed + button to start the program.

A moment after the button is pressed, the treadmill will automatically adjust to the first speed and incline settings of the program. Hold the handrails and begin walking.

Each pulse program is divided into several time segments of different lengths. One target heart rate is programmed for each segment. Note: If pulse program 4 is selected, the same target heart rate is programmed for all segments.

During each segment, the console will regularly compare your heart rate to the current target heart rate. If your heart rate is too far below or above the target heart rate, the speed of the treadmill will automatically increase or decrease to bring your heart rate closer to the target heart rate. If the speed reaches the maximum speed setting of the program (see step 6 on page 16) and your heart rate is still too far below the current target heart rate, the incline of the treadmill will also increase to bring your heart rate closer to the target heart rate.

During the last three seconds of each segment, a series of tones will sound and the Speed display and the Distance/Incline display will flash.

The program will continue until the last segment ends. The walking belt will then slow to a stop.

If the speed or incline setting is too high or too low at any time during the program, you can adjust the setting with the Speed or Incline buttons. However, each time the console compares your heart rate to the current target heart rate, the speed and/or incline of the treadmill may automatically change to bring your heart rate closer to the target heart rate.

If your pulse is not detected during the program, the letters “PLS” will flash in the Calories/Pulse display and the speed and incline of the treadmill will stay the same until your pulse is detected. If this occurs, see CHEST PULSE SENSOR TROUBLESHOOTING on page 9.

To stop the program at any time, press the Stop button. Pulse programs cannot be stopped temporarily and then restarted. To use a pulse program again, reselect the program and start it at the beginning.

### 8 Follow your progress with the displays.

See step 5 on page 12.

### 9 Turn on the fan if desired.

See step 7 on page 13.

### 10 When you are finished exercising, remove the key from the console.

See step 7 on page 15.



# EXPLODED DRAWING—Model No. PETL75133

R0504A

To identify the parts shown on this EXPLODED DRAWING, see the PART LIST on pages 30 and 31 of the user's manual.

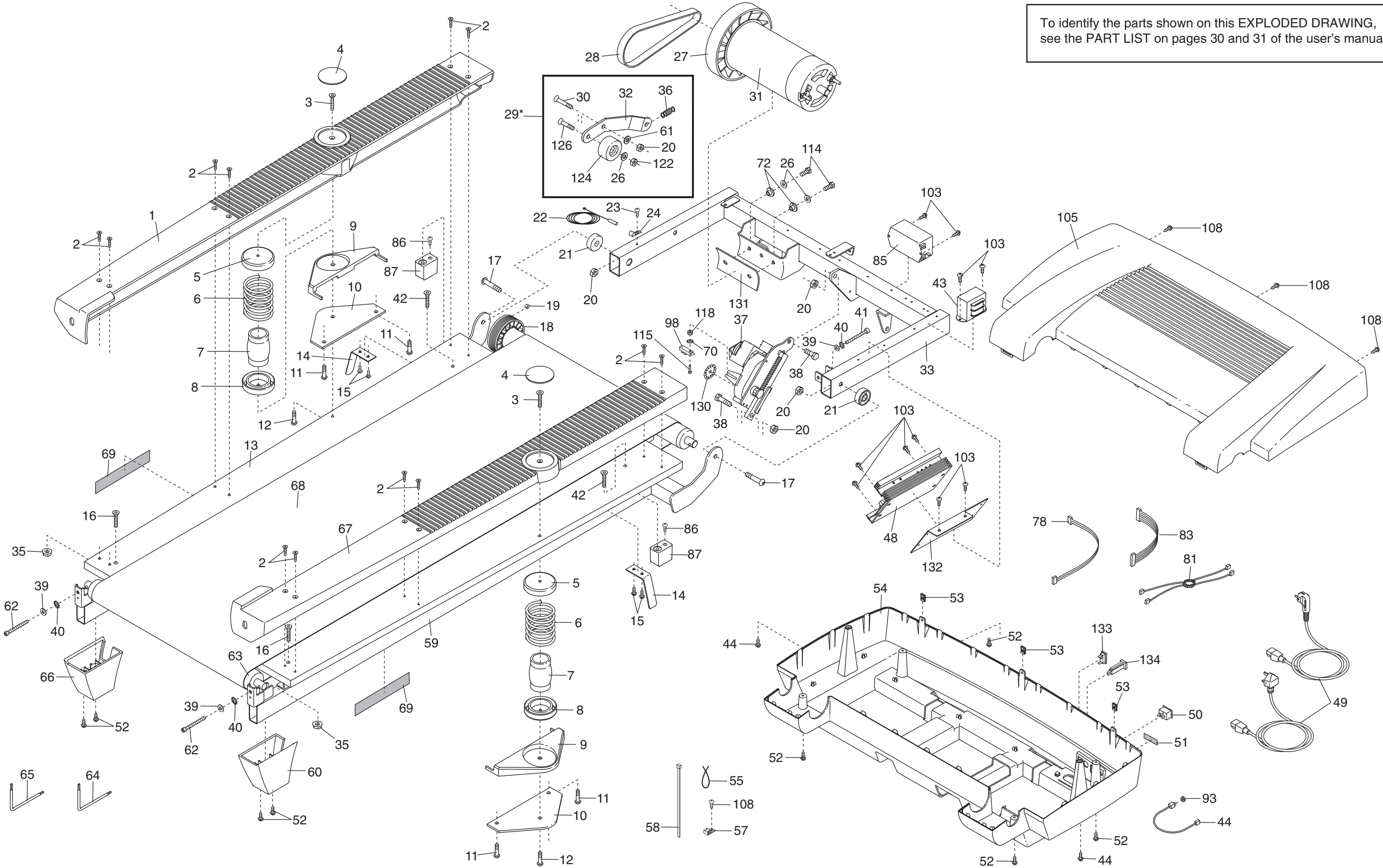

# EXPLODED DRAWING—Model No. PETL75133

R0504A

