

# ARISTA

## Quick Start Guide

### 7000 Series 1 RU – Gen 2 Data Center Switches

DCS-7048T-A	DCS-7050T-64
DCS-7050Q-16	DCS-7124FX
DCS-7050QX-32	DCS-7124SX
DCS-7050S-52	DCS-7150S-24
DCS-7050S-64	DCS-7150S-52
DCS-7050T-36	DCS-7150S-64
DCS-7050T-52	

**Arista Networks**

[www.aristanetworks.com](http://www.aristanetworks.com)

<b>Headquarters</b>	<b>Support</b>	<b>Sales</b>
5453 Great America Parkway Santa Clara, CA 95054 USA		
408 547-5500	408 547-5502 866 476-0000	408 547-5501 866 497-0000
<a href="http://www.aristanetworks.com">www.aristanetworks.com</a>	<a href="mailto:support@aristanetworks.com">support@aristanetworks.com</a>	<a href="mailto:sales@aristanetworks.com">sales@aristanetworks.com</a>

© Copyright 2014 Arista Networks, Inc. The information contained herein is subject to change without notice. Arista Networks and the Arista logo are trademarks of Arista Networks, Inc in the United States and other countries. Other product or service names may be trademarks or service marks of others.

# Chapter 1 Overview

## 1.1 Scope

This guide is intended for properly trained service personnel and technicians who need to install the following Arista Networks Data Center Switches:

- DCS-7048T-A
- DCS-7050Q-16
- DCS-7050QX-32
- DCS-7050S-52
- DCS-7050S-64
- DCS-7050T-36
- DCS-7050T-52
- DCS-7050T-64
- DCS-7124FX
- DCS-7124SX
- DCS-7150S-24
- DCS-7150S-52
- DCS-7150S-64

---

**Important!** Only qualified personnel should install, service, or replace this equipment.

---

## 1.2 Receiving and Inspecting the Equipment

Upon receiving the switch, inspect the shipping boxes and record any external damage. Retain packing materials if you suspect that part of the shipment is damaged; the carrier may need to inspect them.

If the boxes were not damaged in transit, unpack them carefully. Ensure that you do not discard any accessories that may be packaged in the same box as the main unit.

Inspect the packing list and confirm that you received all listed items. Compare the packing list with your purchase order. [Appendix B](#) provides a list of components included with the switch.

## 1.3 Installation Process

The following tasks are required to install and use the switch:

- Step 1** Select and prepare the installation site ([Section 2.1](#)).
- Step 2** Assemble the installation tools listed in [Section 2.2](#).
- Step 3** Attach the mounting brackets and install the switch in an equipment rack ([Chapter 3](#)).
- Step 4** Connect the switch to the power source and network devices ([Chapter 4](#)).
- Step 5** Configure the switch ([Chapter 5](#)).

---

**Important!** Class 1 Laser Product: This product has provisions to install Class 1 laser transceivers which provide optical coupling to the communication network. Once a Class 1 laser product is installed, the equipment is a Class 1 Laser Product (Appareil à Laser de Classe 1). The customer is responsible for selecting and installing the Class 1 laser transceiver and for insuring that the Class 1 AEL (Allowable Emission Limit) per EN/IEC 6-825, CSA E60825-1, and Code of Federal Regulations 21 CFR 1040 is not exceeded after the laser transceiver have been installed. Do not install laser products whose class rating is greater than 1. Refer to all safety instructions that accompanied the transceiver prior to installation. Only Class 1 laser devices, certified for use in the country of installation by the cognizant agency are to be utilized in this product.

---

---

**Important!** Ultimate disposal of this product should be in accordance with all applicable laws and regulations.

---

## 1.4 Safety Information

Refer to the Arista Networks document Safety Information and Translated Safety Warnings available at:

<http://www.aristanetworks.com/en/support/docs/eos>

## 1.5 Obtaining Technical Assistance

Any customer, partner, reseller or distributor holding a valid Arista Service Contract can obtain technical support in any of the following ways:

- **Email:** [support@aristanetworks.com](mailto:support@aristanetworks.com). This is the easiest way to create a new service request. Include a detailed description of the problem and the output of “show tech-support”.
- **Web:** [www.aristanetworks.com/en/support](http://www.aristanetworks.com/en/support).  
A support case may be created through the support portal on our website. You may also download the most current software and documentation, as well as view FAQs, Knowledge Base articles, Security Advisories, and Field Notices.
- **Phone:** 866-476-0000 or 408-547-5502.

---

**Important!** No user serviceable parts inside. Refer all servicing to qualified service personnel.

---

## 1.6 Specifications

Table 1 lists the specifications of Arista Data Center switches covered by this guide.

**Table 1: Switch Specifications**

<b>Size</b>	all switches all switches all switches	Height: 44 mm (1.75 inches) – 1 RU Width: 445 mm (19 inches) Depth: 406 mm (16 inches)
<b>Weight</b>	DCS-7048T-A DCS-7050Q-16 DCS-7050QX-32 DCS-7050S-52 / DCS-7050S-64 DCS-7050T-36 DCS-7050T-52 / DCS-7050T-64 DCS-7124FX DCS-7124SX DCS-7150S-24 DCS-7150S-52 / DCS-7150S-64	7.7 kg (17 pounds) 8.2 kg (18 pounds) 9.1 kg (20 pounds) 7.7 kg (17 pounds) 8.2 kg (18 pounds) 9.5 kg (21 pounds) 8.2 kg (18 pounds) 7.7 kg (17 pounds) 8.2 kg (18 pounds) 8.6 kg (19 pounds)
<b>Operating Temperature</b>	DCS-7150S-52-R / DCS-7150S-64-R all other switches	0° to 35° C (32° to 95° F) 0° to 40° C (32° to 104° F)
<b>Storage Temperature</b>	all switches	-40° to 70° C (-40° to 158° F)
<b>Operating Altitude</b>	all switches	0 to 3,000 meters (0 to 10,000 feet)
<b>Relative Humidity</b>	all switches	5 to 90%
<b>Power Input (AC Power)</b>	all switches	100-240 VAC, 5.29-2.2 A, 50/60 Hz
<b>Power Input (DC Power)</b>	all switches	40-72 VDC, 13.9-7.72 A
<b>Power Output</b>	all switches	Output: 460 W
<b>Power Draw (Typical / Maximum)</b>	DCS-7048T-A DCS-7050Q-16 DCS-7050QX-32 DCS-7050S-52 DCS-7050S-64 DCS-7050T-36 DCS-7050T-52 DCS-7050T-64 DCS-7124SX DCS-7124FX DCS-7150S-24 DCS-7150S-52 DCS-7150S-64	280 W / 390 W 192 W / 303 W 162 W / 332 W 103 W / 185 W 125 W / 220 W 244 W / 289 W 347 W / 405 W 372 W / 430 W 120 W / 210 W 150 W / 240 W 191 W / 334 W 191 W / 450 W 224 W / 455 W

## Chapter 2 Preparation

### 2.1 Site Selection

The following criteria should be considered when selecting a site to install the switch:

- **Temperature and Ventilation:** For proper ventilation, install the switch where there is ample airflow to the front and back of the switch. The ambient temperature should not go below 0° or exceed 40° C.

---

**Important!** To prevent the switch from overheating, do not operate it in an area where the ambient temperature exceeds 40°C (104°F).

---

- **Airflow Orientation:** Determine the airflow direction of the four fan modules and two power supply modules on the rear panel. [Figure 1](#) indicates the location of the airflow direction label on the power supply modules. The fan module airflow direction label is located on the left side of the handle. The fan and power supply module handles also indicate the module airflow direction:

- **Blue Handle:** Air Inlet module.
- **Red Handle:** Air Exit module.

Verify that each module has the same airflow direction. Base the switch orientation on the airflow direction of the modules to assure the air inlet is always oriented toward the cool aisle:

- **Air Exit modules:** orient the rear panel toward the hot aisle.
- **Air Inlet modules:** orient the rear panel toward the cool aisle.

If the airflow direction is not compatible with the installation site, contact your sales representative to obtain modules that circulate air in the opposite direction.

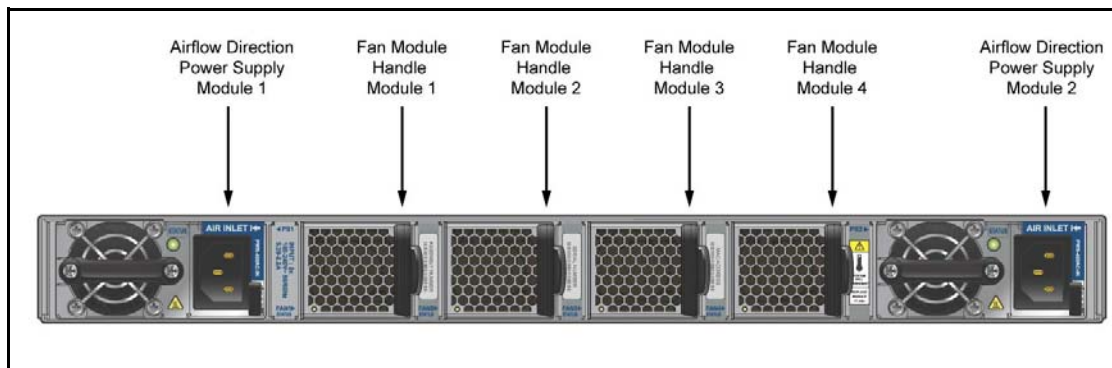

**Figure 1: Airflow Direction Labels**

- **Rack Space:** Install the switch in a 19" rack or cabinet. The switch height is 1 RU. The accessory kit provides mounting brackets for two-post and four-post racks.

When mounting the switch in a partially filled rack, load the rack from bottom to top, with the heaviest equipment at the bottom. Load the switch at the bottom if it is the only item in the rack.

- **Power Requirements:** The switch requires one of these circuits:
  - 100-240 VAC, 5.29-2.2 A, 50-60 Hz A.
  - 40-72 VDC, 13.9–7.72 A.

Two circuits provide redundancy protection. [Section 4.1](#) describes power cable requirements.

---

**Important!** The power input plug-socket combination must be accessible at all times; it provides the primary method of disconnecting power from the system.

---

- **Other Requirements:** Select a site where liquids or objects cannot fall onto the equipment and foreign objects are not drawn into the ventilation holes. Verify these guidelines are met:
  - Clearance areas to the front and rear panels allow for unrestricted cabling.
  - All front and rear panel indicators can be easily read.
  - Power cords can reach from the power outlet to the connector on the rear panel.

---

**Important!** All power connections must be removed to de-energize the unit.

---

## 2.2 Tools Required for Installation

The following tools and equipment are required to install the switch:

- Phillips #1 screwdriver.
- Phillips #3 screwdriver.
- Four screws (two-post rack mount) that fit the equipment rack.
- Eight screws (four-post rack mount) that fit the equipment rack.

The accessory kit does not include screws for attaching the switch to the equipment rack. When installing the switch into an equipment rack with unthreaded post holes, nuts are also required to secure the switch to the rack posts.

## 2.3 Electrostatic Discharge (ESD) Precautions

Observe these guidelines to avoid ESD damage when installing or servicing the switch.

- Assemble or disassemble equipment only in a static-free work area.
- Use a conductive work surface (such as an antistatic mat) to dissipate static charge.
- Wear a conductive wrist strap to dissipate static charge accumulation.
- Minimize handling of assemblies and components.
- Keep replacement parts in their original static-free packaging.
- Remove all plastic, foam, vinyl, paper, and other static-generating materials from the work area.
- Use tools that do not create ESD.

## Chapter 3 Rack Mounting the Switch

**Important!** The rack mounting procedure is identical for all switches covered by this guide. Illustrations in this chapter depict the mounting of a DCS-7124SX switch.

The accessory kit provides components for installing the switch in two-post and four-post racks.

- [Section 3.1](#) provides instructions for mounting the switch in a two-post rack.
- [Section 3.2](#) provides instructions for mounting the switch in a four-post rack.

Both options require the attachment of mounting brackets to the switch chassis. Each chassis side contains six pairs of holes that align with bracket holes. Bracket hole orientation is symmetric, allowing bracket placements where the flange is flush with the front or rear switch panel ([Figure 2](#)).

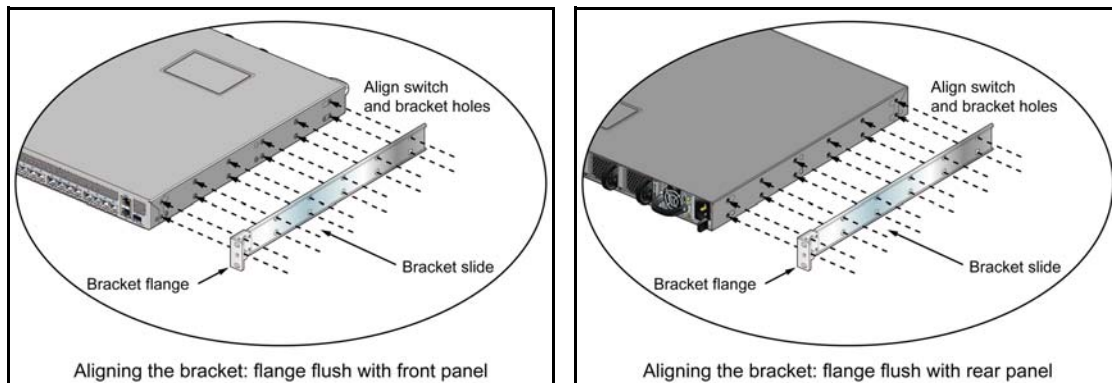

**Figure 2: Chassis and Mounting Bracket Alignment for Front and Rear Rack Mounts**

Bracket holes are horizontally equidistant, allowing bracket placements where the flange is not flush with either panel ([Figure 3](#)). This placement supports a center-rack mount.

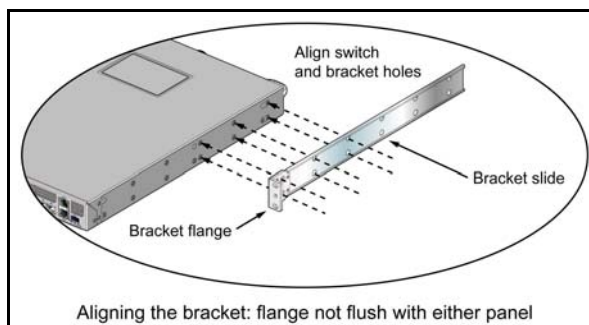

**Figure 3: Chassis and Mounting Bracket Alignment for Center Rack Mount**

After completing the instructions for your rack type, proceed to [Chapter 4: Cabling the Switch](#).

### 3.1 Two-Post Rack Mount

To mount the switch onto a two-post rack, assemble the mounting brackets to the chassis, then attach the brackets to the rack posts. The accessory kit includes the following two-post mounting parts:

- 2 mounting brackets
- 12 M4x5 flat head Phillips screws

Refer to [Figure 2](#) and [Figure 3](#) for a description of the mounting brackets.

The switch supports any mounting position into a two-post rack that meets the following conditions:

- The bracket flanges do not extend beyond the switch chassis.
- Three sets of screws attach each mounting bracket to the chassis.

[Figure 4](#) displays proper bracket mount configuration examples.

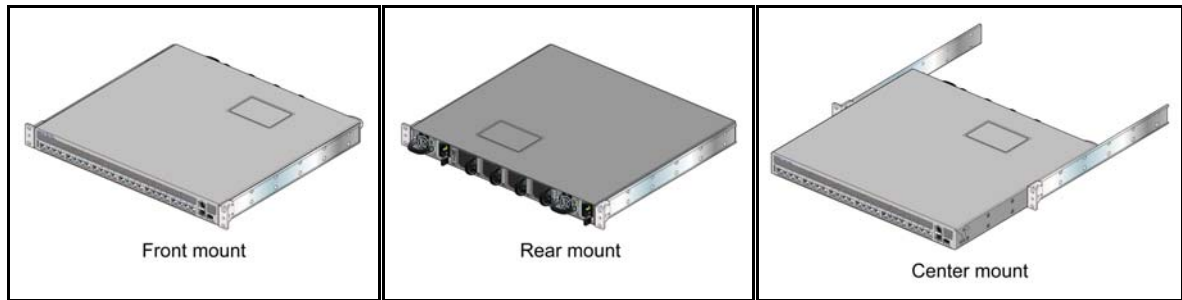

**Figure 4: Bracket Mount Examples for Two-Post Rack Mount**

[Figure 5](#) displays improper bracket mount configuration examples.

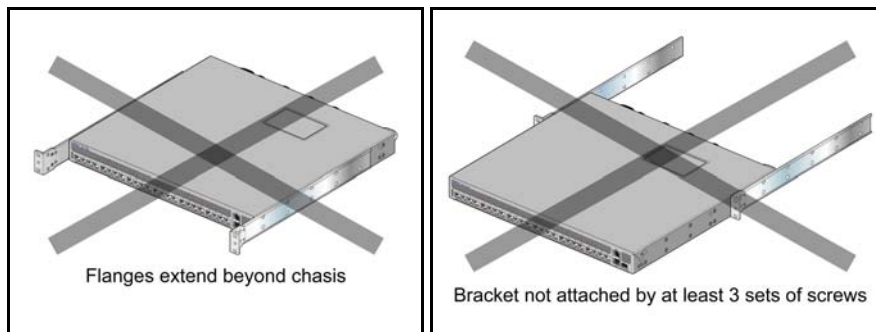

**Figure 5: Improper Bracket Mount Examples for Two-Post Rack Mount**



### 3.1.1 Attaching Mounting Brackets to the Chassis

To attach mounting brackets to the switch chassis, perform this procedure:

**Step 1** Align the mounting brackets with the chassis to obtain the desired mounting position.

**Step 2** Attach the brackets with six M4x5 flat head Phillips screws per bracket, using a #1 Phillips screwdriver.

Space the screws evenly, separating them with the widest possible distance. [Figure 6](#) displays screw placement for the front and center mount positions.

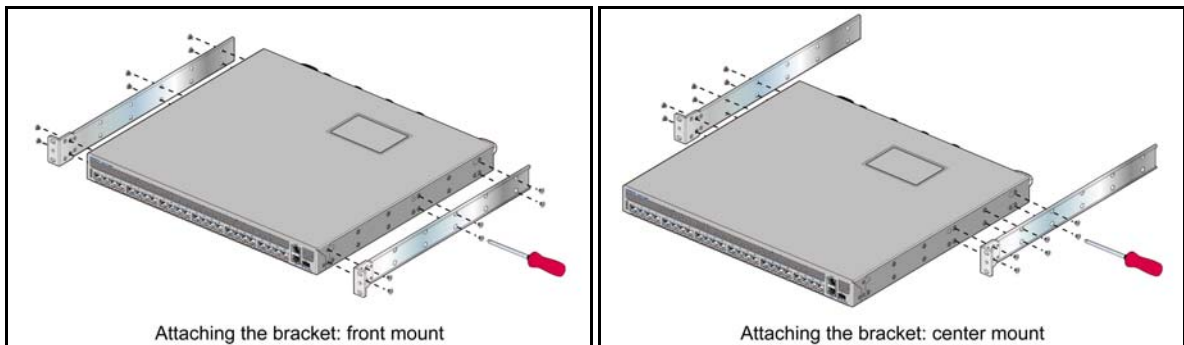
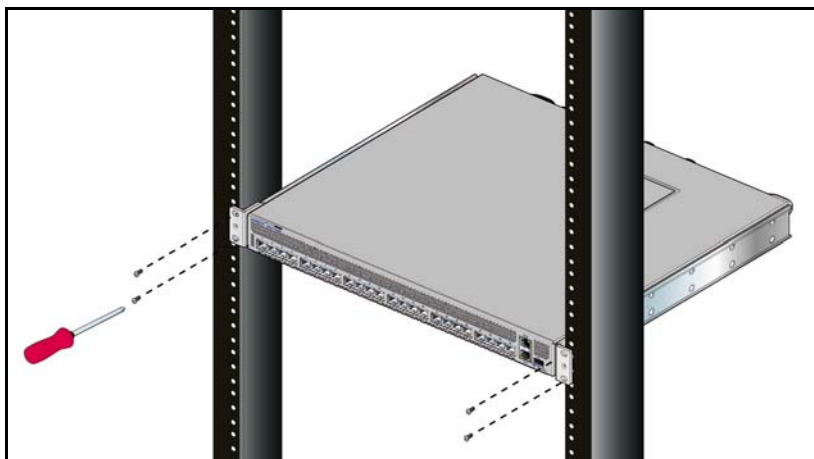

**Figure 6: Attaching the Mounting Brackets to the Switch Chassis**

### 3.1.2 Inserting the Switch into the Rack

**Step 1** Lift the chassis into the rack. Position the flanges against the rack posts.

[Figure 7](#) displays the front-mount switch installation.



**Figure 7: Inserting the Switch into the Rack**

**Step 2** Select mounting screws that fit your equipment rack.

**Step 3** Attach the bracket flanges to the rack posts.

After completing the two-post rack mount, proceed to [Chapter 4: Cabling the Switch](#).

## 3.2 Four-Post Rack Mount

The switch is mounted onto a four-post rack by assembling two rails onto the rear posts, sliding the switch onto the rails, then securing the switch to the front post.

The installation kit provides the following four-post mounting parts:

- 2 mounting brackets
- 2 rails
- 12 M4x5 flat head Phillips screws

Refer to [Figure 2](#) and [Figure 3](#) for a description of the mounting brackets.

The switch supports any mounting position where at least three sets of screws attach each mounting bracket to the switch chassis.

[Figure 8](#) displays proper bracket mount configuration examples.

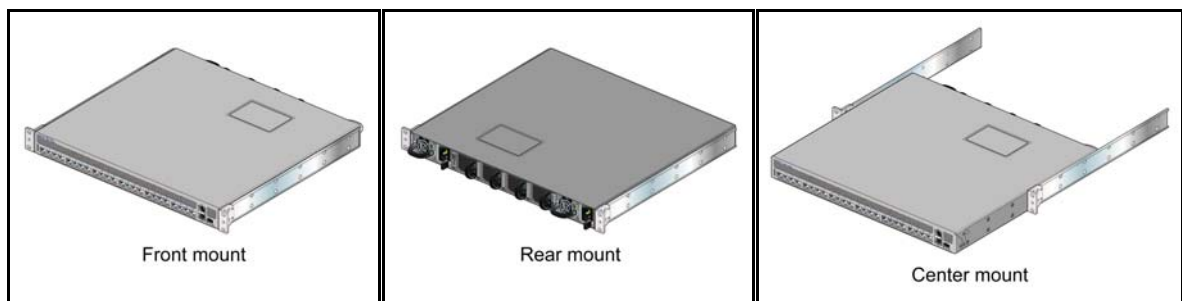

**Figure 8: Bracket Mount Examples for Four-Post Rack Mount**

[Figure 9](#) displays an improper bracket mount configuration example.

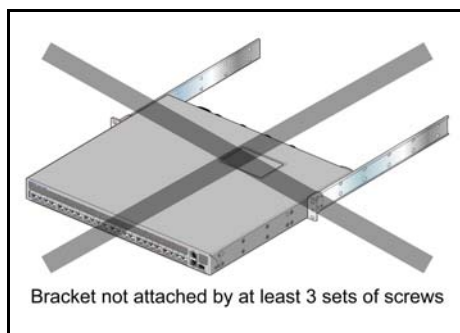

**Figure 9: Improper Bracket Mount Example for Four-Post Rack Mount**

### 3.2.1 Attaching Mounting Brackets to the Chassis

To attach mounting brackets to the switch chassis, perform this procedure:

- Step 1** Align the mounting brackets with the chassis to obtain the desired mounting position.
- Step 2** Attach the brackets with six M4x5 flat head Phillips screws per bracket, using a #1 Phillips screwdriver.

Space the screws evenly, separating them with the widest possible distance. [Figure 10](#) displays screw placement for the front mount and center mount positions.

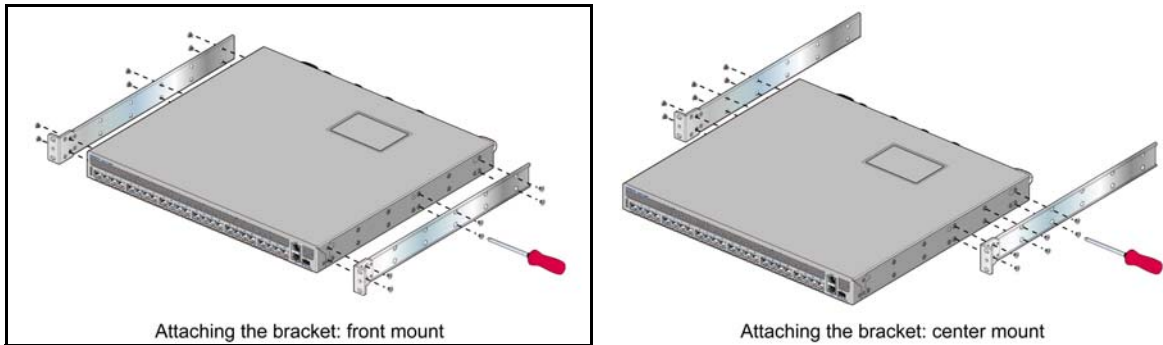

**Figure 10: Attaching the Mounting Brackets to the Switch Chassis**

### 3.2.2 Assembling the Rails onto the Equipment Rack

The rails attach to the rear rack posts to support the switch. Before attaching the rails to the rack posts, verify that, when the switch is mounted, the distance between the bracket flanges and rail flanges does not exceed 30 inches, as shown in [Figure 11](#).

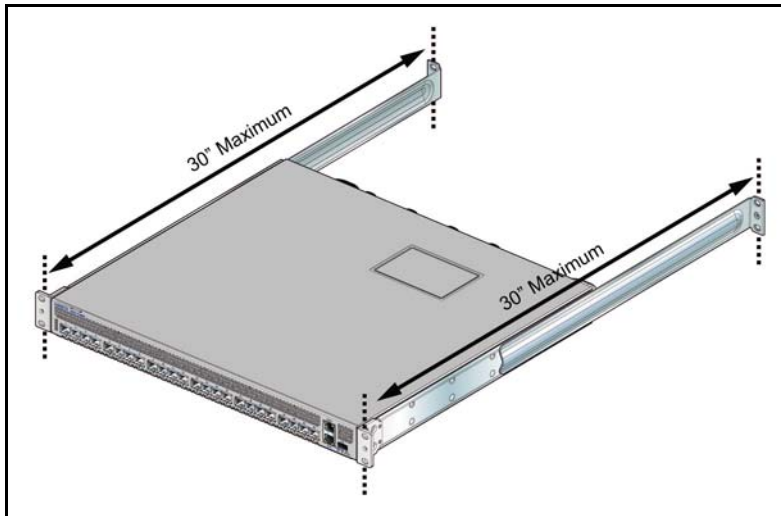
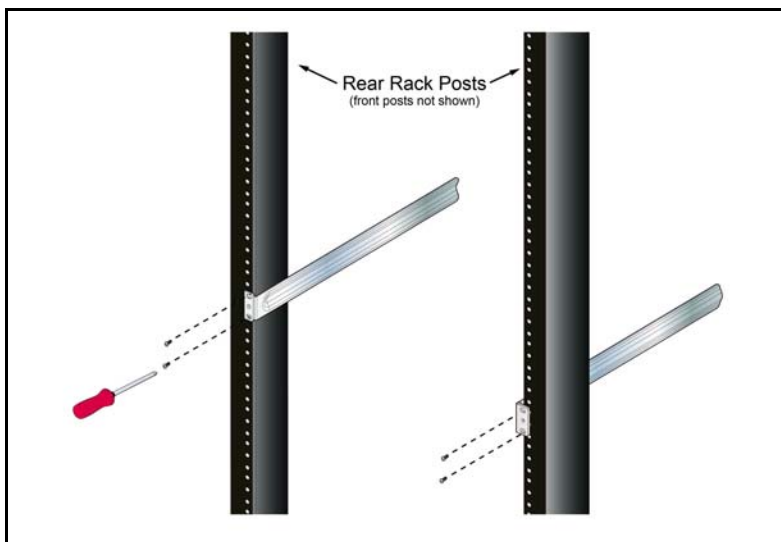

**Figure 11: Maximum Bracket-Rail Span**

To attach the rails to the rear rack post, perform this procedure:

**Step 1** Select mounting screws that fit your equipment rack. Each rail requires two screws.

**Step 2** Attach the rails to the rear rack posts, as shown in [Figure 12](#).



**Figure 12: Attaching the Rails, as viewed from Rear of Rack**

### 3.2.3 Attaching the Switch to the Rack

**Step 1** Lift the switch into the rack and insert the mounting brackets onto the rails.

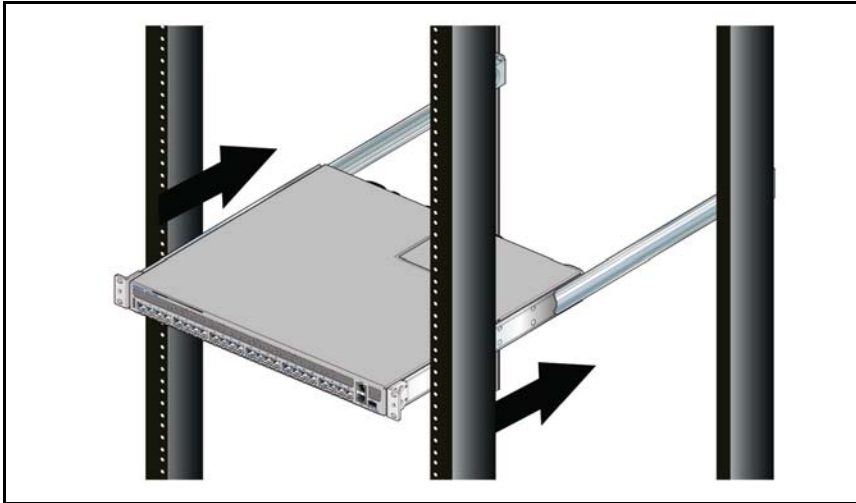

**Figure 13: Inserting the Switch onto the Rails**

**Step 2** Slide the switch on the rails, toward the rear posts, until the mounting bracket flanges are positioned on the rail posts.

**Step 3** Select mounting screws that fit the equipment rack. Each chassis side requires two screws.

**Step 4** Verify the distance between the mounting bracket flanges and rail flanges does not exceed 30 inches. See [Figure 11](#).

**Step 5** Attach the bracket flanges to the rack posts.

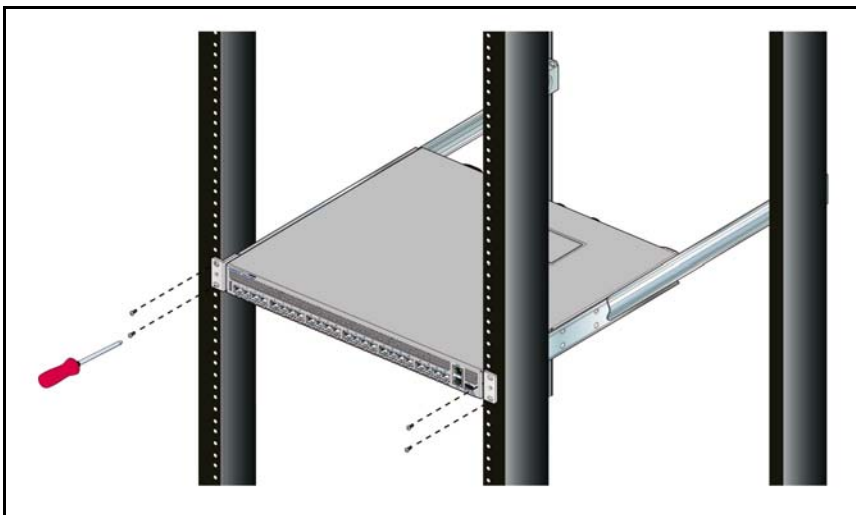

**Figure 14: Attaching the Switch to the Rack Posts**

After completing the four-post rack mount, proceed to [Chapter 4: Cabling the Switch](#).

## Chapter 4 Cabling the Switch

### 4.1 Connecting Power Cables

---

**Important!** Installation of this equipment must comply with local and national electrical codes. If necessary, consult with the appropriate regulatory agencies and inspection authorities to ensure compliance.

---

The switch operates with two installed power supplies. At least one power supply must connect to a power source. Two circuits provide redundancy protection.

[Appendix D](#) displays the location of the power supplies on the rear panel of the switch.

---

**Important!** Read all installation instructions before connecting the system to the power source.

---

- **Non-Redundant Configuration:** Connect power to either of the two power supplies.
  - **Redundant Power Supply Configuration:** Connect power to both power supplies.
  - **Power down the Switch:** Remove all power cords and wires from the power supplies.
- 

**Important!** This equipment must be grounded. Never defeat the ground conductor.

---

---

**Important!** This unit requires overcurrent protection.

---

#### 4.1.1 AC Power Supply

The AC power supply connects to a circuit that provides 100-240 VAC, 50 or 60 Hz, and 5.29-2.2 A. [Figure 15](#) displays an AC power supply, including the power socket on the right side of the module.

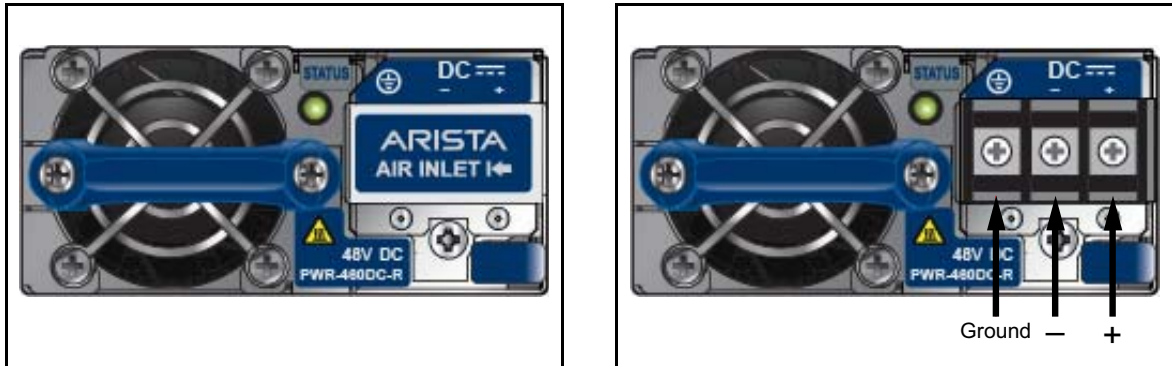

**Figure 15: AC Power Supply**

The power supplies require power cables that comply with IEC-320 and have a C13 plug. The accessory kit provides two IEC-320 C13 to C14 power cables, each two meters long.

### 4.1.2 DC Power Supply

The DC power supply connects to a circuit that provides 40-72 VDC and 13.9–7.72 A. [Figure 16](#) displays the DC power supply with the terminal cover in place (left illustration) and with the terminal cover removed (right illustration).



**Figure 16: DC Power Supply – terminal cover in place (left); terminal cover removed (right)**

Ensure the wires connecting the DC power supply to the power source meet the following:

- DC Input Wire Size: AWG 14 (2.0 mm<sup>2</sup>) or larger as appropriate
- Safety Ground Wire Size: AWG 14 (2.0 mm<sup>2</sup>) or larger as appropriate
- Wire Terminal (Lug): ring or spade, 14-16 AWG, #8 (4 mm) screw
- Overcurrent protection: 20 A.

**Important!** Ensure power is removed from DC circuits before performing any installation actions. Locate circuit breakers or fuses on DC power lines servicing the circuits. Turn off the power line circuits or remove the fuses.

To connect a DC power supply to power source:

**Step 1** Remove the terminal cover to expose the connectors on the right side of the module ([Figure 16](#)).

**Step 2** Attach the appropriate lugs to the source DC wires.

Use DC cables with either insulated crimp-on spade lugs or insulated crimp-on ring connectors.

**Important!** Wire size must comply with local and national requirements and electrical codes. Use only copper wire.

**Step 3** Connect the DC-input wires to the terminal block in this order:

1. Ground cable to the ground connector on the terminal block.
2. Negative (-) source DC cable to the negative (-) connector on the terminal block.
3. Positive (+) source DC cable to the positive (+) connector on the terminal block.

**Important!** Apply the ground connection first during installation and remove last when removing power.

**Step 4** Replace the terminal cover.

## 4.2 Connecting Serial and Management Cables

The accessory kit includes the following cables:

- RJ-45 to DB-9 serial adapter cable.
- RJ-45 Ethernet cable.

Table 2 lists the pin connections of the RJ-45 to DB-9 adapter cable.

**Table 2: RJ-45 to DB-9 Connections**

RJ-45		DB-9		RJ-45		DB-9	
RTS	1	8	CTS	GND	5	5	GND
DTR	2	6	DSR	RXD	6	3	TXD
TXD	3	2	RXD	DSR	7	4	DTR
GND	4	5	GND	CTS	8	7	RTS

The front panel contains the console, management, and USB ports. Figure 17 displays the ports on the 7124FX switch. Appendix C displays the front panel of all switches covered by this guide.

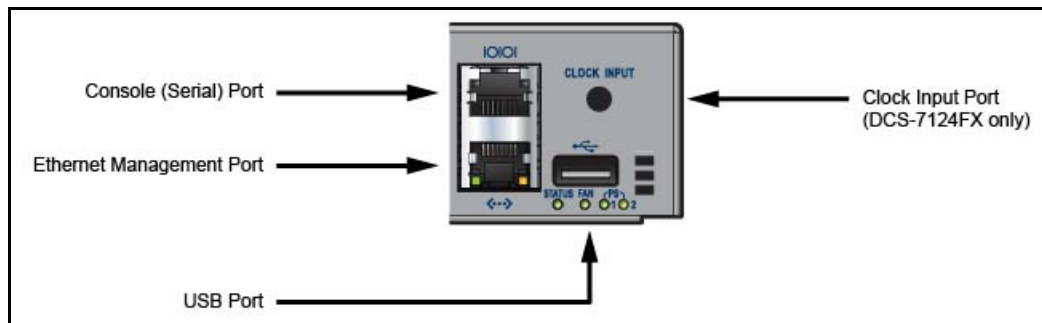

**Figure 17: Front Panel Ports**

Connect the front panel ports as follows:

- **Console (Serial) Port:** Connect to a PC with the RJ-45 to DB-9 serial adapter cable. The switch uses the following default settings:
  - 9600 baud
  - No flow control
  - 1 stop bit
  - No parity bits
  - 8 data bits
- **Ethernet Management Port:** Connect to 10/100/1000 management network with RJ-45 Ethernet cable.
- **USB Port:** The USB port may be used for software or configuration updates.
- **Clock Input Port:** Port type is MCX connector, 2-5.5V, 50 ohm termination.

---

**Caution** Excessive bending can damage interface cables, especially optical cables.

---



## Chapter 5 Configuring the Switch

Arista switches ship from the factory in Zero Touch Provisioning (ZTP) mode. ZTP configures the switch without user intervention by downloading a startup configuration file or a boot script from a location specified by a DHCP server. To manually configure a switch, ZTP is bypassed. The initial configuration provides one username (*admin*) accessible only through the console port because it has no password.

When bypassing ZTP, initial switch access requires logging in as *admin*, with no password, through the console port. Then you can configure an *admin* password and other password protected usernames.

This manual configuration procedure cancels ZTP mode, logs into the switch, assigns a password to *admin*, assigns an IP address to the management port, and defines a default route to a network gateway.

**Step 1** Provide power to the switch (Section 4.1).

**Step 2** Connect the console port to a PC (Section 4.2).

As the switch boots without a *startup-config* file, it displays the following through the console:

```
The device is in Zero Touch Provisioning mode and is attempting to
download the startup-config from a remote system. The device will not
be fully functional until either a valid startup-config is downloaded
from a remote system or Zero Touch Provisioning is cancelled. To cancel
Zero Touch Provisioning, login as admin and type 'zerotouch cancel'
at the CLI.
```

```
localhost login:
```

**Step 3** Log into the switch by typing **admin** at the login prompt.

```
localhost login:admin
```

**Step 4** Cancel ZTP mode by typing **zerotouch cancel**. *IMPORTANT: This step initiates a switch reboot.*

```
localhost>zerotouch cancel
```

**Step 5** After the switch boots, log into the switch again by typing **admin** at the login prompt.

```
Arista EOS
localhost login:admin
Last login: Fri Mar 15 13:17:13 on console
```

**Step 6** Enter global configuration mode.

```
localhost>enable
localhost#config
```

**Step 7** Assign a password to the *admin* username with the **username secret** command.

```
localhost (config)#username admin secret pxq123
```

**Step 8** Configure a default route to the network gateway.

```
localhost (config)#ip route 0.0.0.0/0 192.0.2.1
```

**Step 9** Assign an IP address (*192.0.2.8/24* in this example) to an Ethernet management port.

```
localhost (config)#interface management 1
localhost (config-if-Ma1)#ip address 192.0.2.8/24
```

**Step 10** Save the configuration by typing **write memory** or **copy running-config startup-config**.

```
localhost (config-if-Ma1)#copy running-config startup-config
```

When the management port IP address is configured, use this command to access the switch from a host, using the address configured in step 9:

```
ssh admin@192.0.2.8
```

Refer to the **Arista Networks User Manual** for complete switch configuration information.



# Appendix A Status Indicators

## A.1 Front Indicators

### A.1.1 Switch Indicators

Front panel LEDs are located on the right side of the chassis and display system, fan, and power supply status. [Appendix C](#) displays the front panels of all switches covered by this guide.

Figure 18 shows 7124SX front panel LEDs.

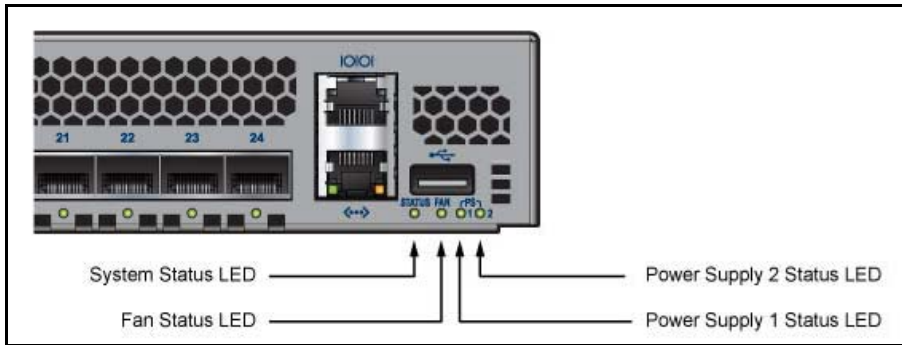

Figure 18: System Status Indicators

Table 3: System Status LED States

LED State	Status
Blinking Green	System powering up.
Green	All power supplies and fans are operating normally.
Blue	The locator function is active.
Red	A power supply or fan is missing or in a failed state.

Table 4: Fan Module Status LED States

LED State	Status
Green	All fans are operating normally.
Red	One or more fans are not inserted or have failed.

Table 5: Power Supply Status LED States

LED State	Status
Off	Power supply is not inserted or is not powered.
Green	Power supply operating normally.
Red	Power supply has failed.

## A.1.2 Port Indicators

Port LEDs, located in the vicinity of their corresponding ports, provide link and operational status. [Figure 19](#) displays the Port LED location on the 7124SX switch. [Appendix C](#) displays the port LED locations of all switches covered by this guide.

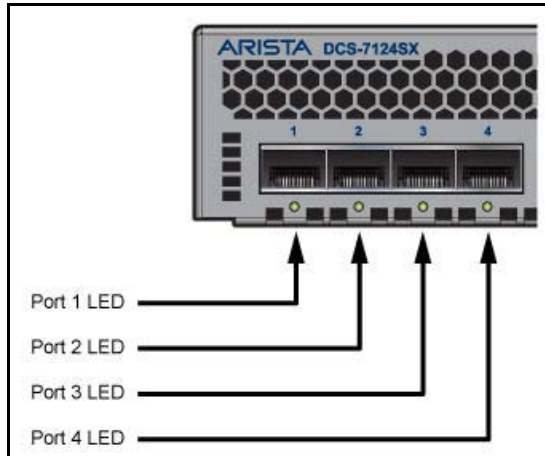

**Figure 19: Port LEDs**

[Table 6](#) provides status conditions that correspond to port LED states. Port LED behavior for QSFP+ and SFP+ ports is consistent.

**Table 6: Port LED States**

LED State	Status
Off	Port link is down.
Green	Port link is up.
Yellow	Port is software disabled.
Flashing Yellow	Port failed diagnostics.

## A.2 Rear Status Indicators

Fan and power supply modules are accessed from the rear panel. [Section D](#) displays the rear panel of all switches covered by this guide.

Each fan and power supply module contains an LED that reports the module status.

The Fan Status LEDs are on the fan modules, as displayed in [Figure 20](#).

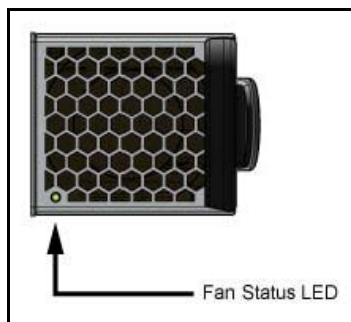
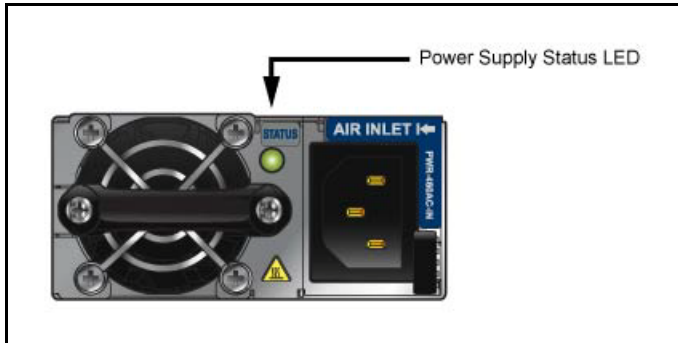

**Figure 20: Fan Status LED**

**Table 7: Fan Status LED States**

LED State	Status
Off	The fan module is inserted but not receiving power – it may not be properly seated.
Green	The fan is operating normally.
Red	The fan has failed or a power supply module was removed from the switch.

The Power Supply Status LEDs are on the power supply modules, as displayed in [Figure 21](#).



**Figure 21: Power Supply Status LED**

**Table 8: Power Supply Status LED States**

LED State	Status
Off	Power supply not connected to AC power or not inserted fully.
Green	Power supply operating normally.
Amber	Power supply has overheated or failed.

## Appendix B Parts List

Each switch provides an accessory kit that contains parts that are required to install the switch. The following sections list the installation parts contained in the switch accessory kit.

### B.1 Rack Mount Parts

All two-post rack mount parts are also used in the four-post mount.

Quantity	Description	Installation Usage
2	Mounting Brackets	Two-Post and Four-Post
2	Rails	Four-Post
12	M4x5 flat head Phillips screws	Two-Post and Four-Post

#### B.1.1 Two-Post Rack Mount

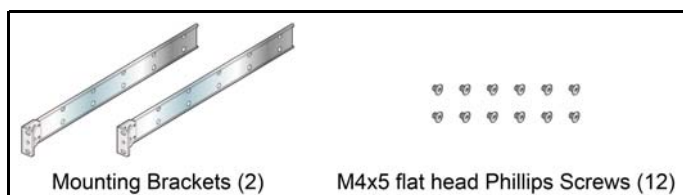

Figure 22: Two-Post Rack Mount Parts

#### B.1.2 Four-Post Rack Mount

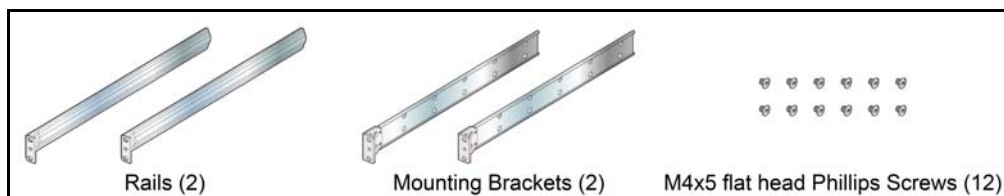

Figure 23: Four-Post Rack Mount Parts

### B.2 Cables

Quantity	Description
2	Power cables: IEC-320/C13-C14, 13 A, 250 V, 2 meter
1	RJ-45 Patch Panel Cable, 2 meter
1	RJ-45 to DB9 Adapter Cable, 2 meter

**Warning!** All provided power cables are for use only with Arista products.

#### 警告

すべての電源コードは提供する製品で使用するためだけを目的としている。

#### 電源コードの他の製品での使用の禁止

Arista が提供するすべての電源コードは、Arista の製品でのみ使用してください。

# Appendix C Front Panel

This appendix displays the front panel of all switches covered by this guide.

## DCS-7048T-A

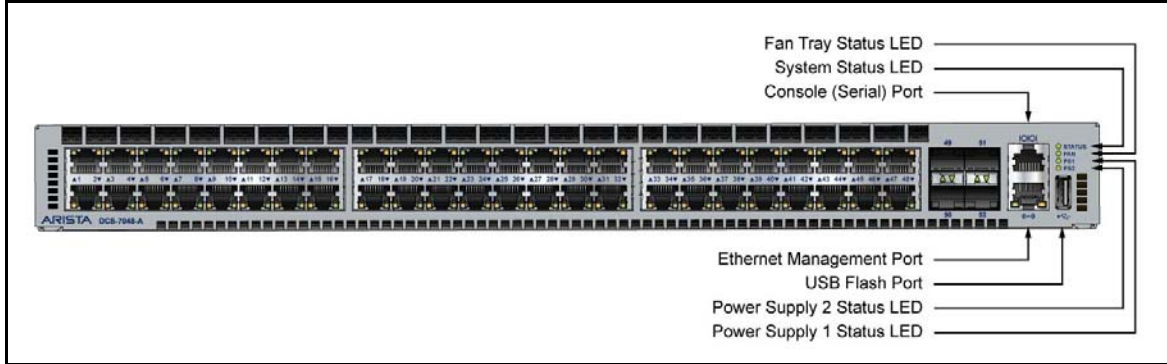

Figure 24: DCS-7048T-A Front Panel

## DCS-7050Q-16

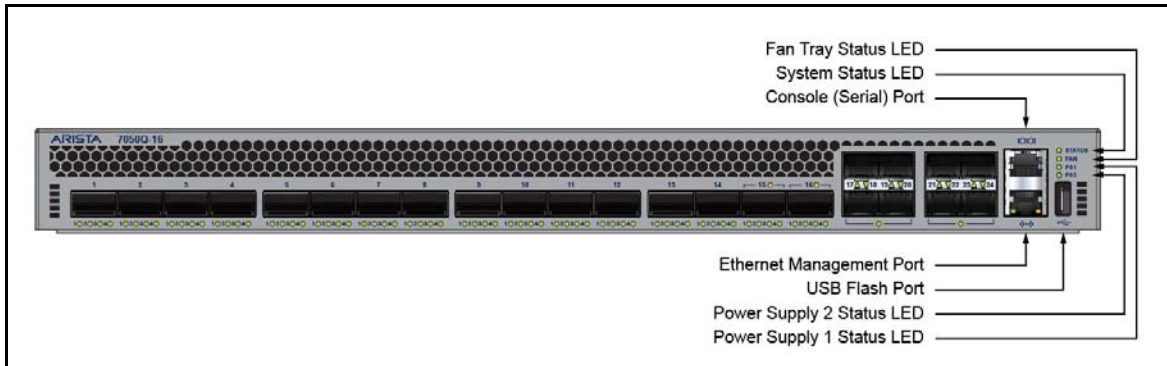

Figure 25: DCS-7050Q-16 Front Panel

## DCS-7050QX-32

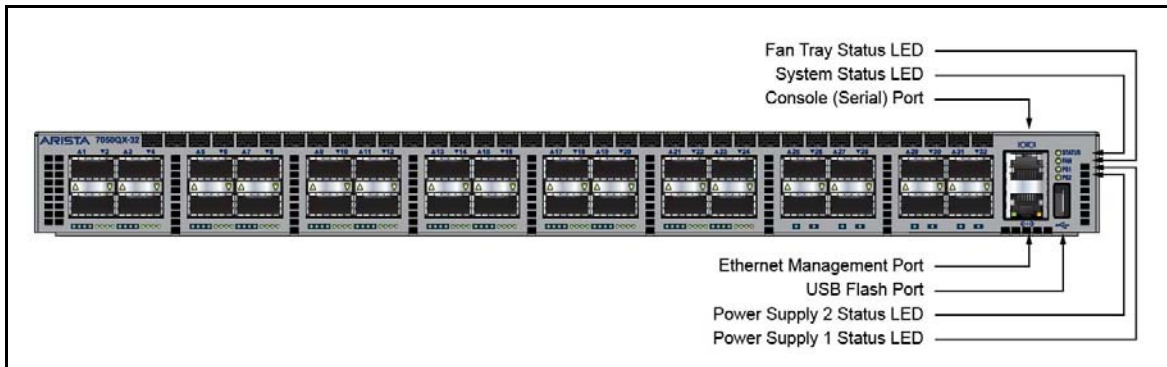
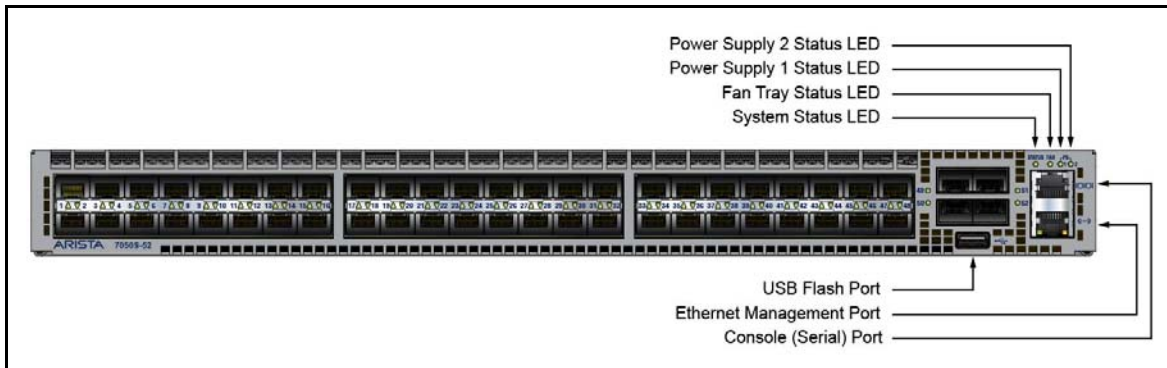

Figure 26: DCS-7050QX-32 Front Panel

**DCS-7050S-52**



**Figure 27: DCS-7050S-52 Front Panel**

**DCS-7050S-64**

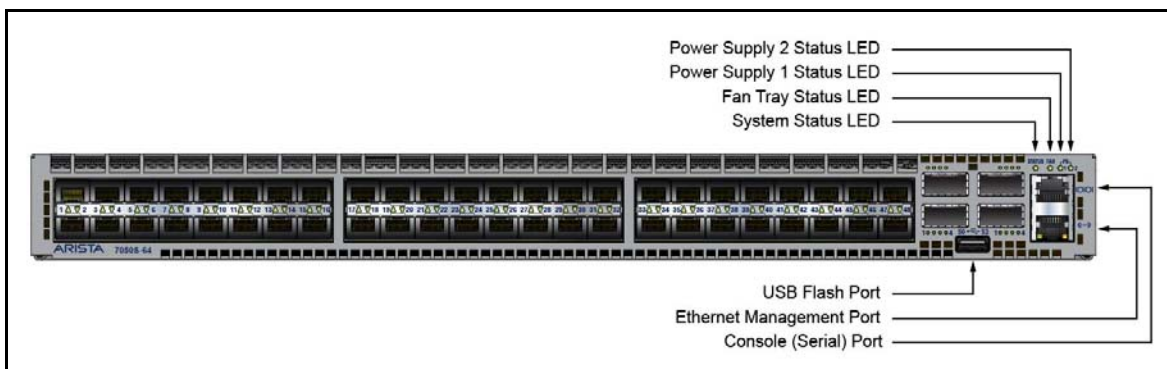

**Figure 28: DCS-7050S-64 Front Panel**

**DCS-7050T-36**

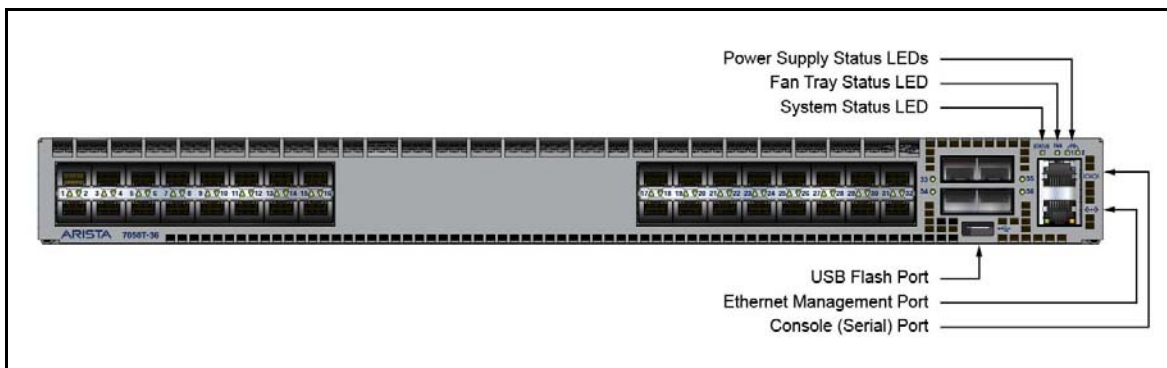

**Figure 29: DCS-7050T-36 Front Panel**



**DCS-7050T-52**

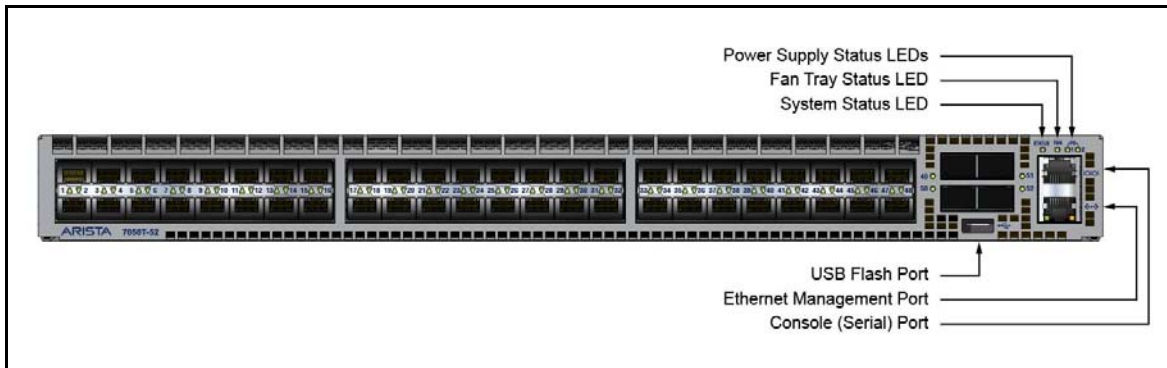

**Figure 30: DCS-7050T-52 Front Panel**

**DCS-7050T-64**

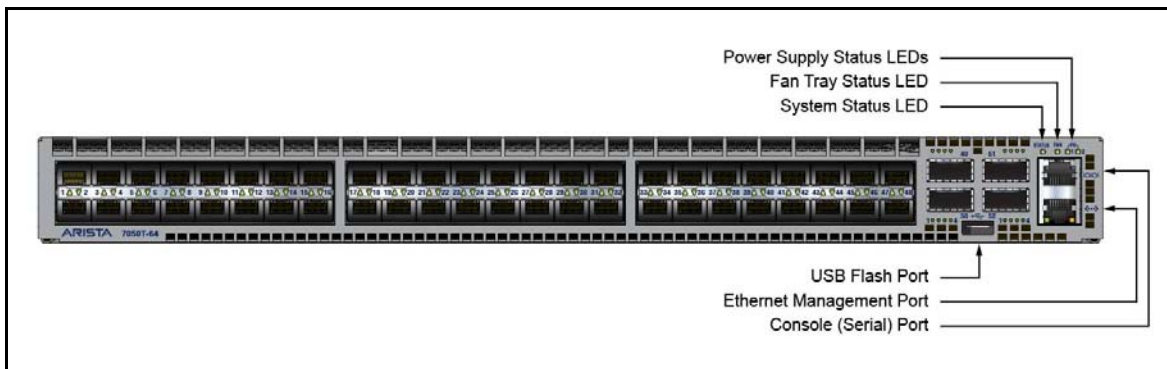

**Figure 31: DCS-7050T-64 Front Panel**

**DCS-7124FX**

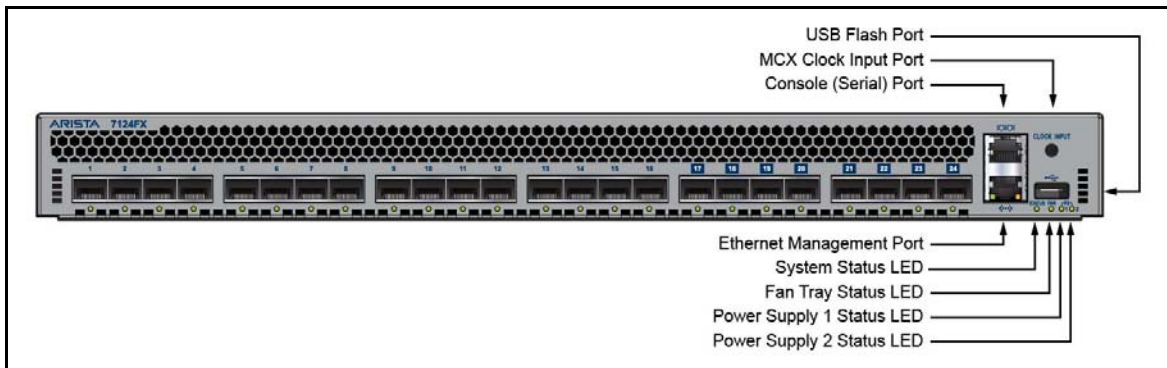

**Figure 32: DCS-7124FX Front Panel**

DCS-7124SX

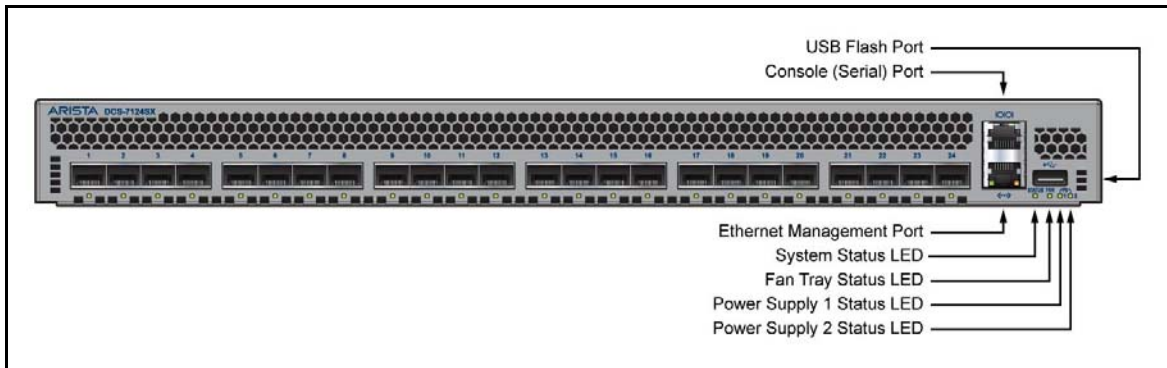

Figure 33: DCS-7124SX Front Panel

DCS-7150S-24

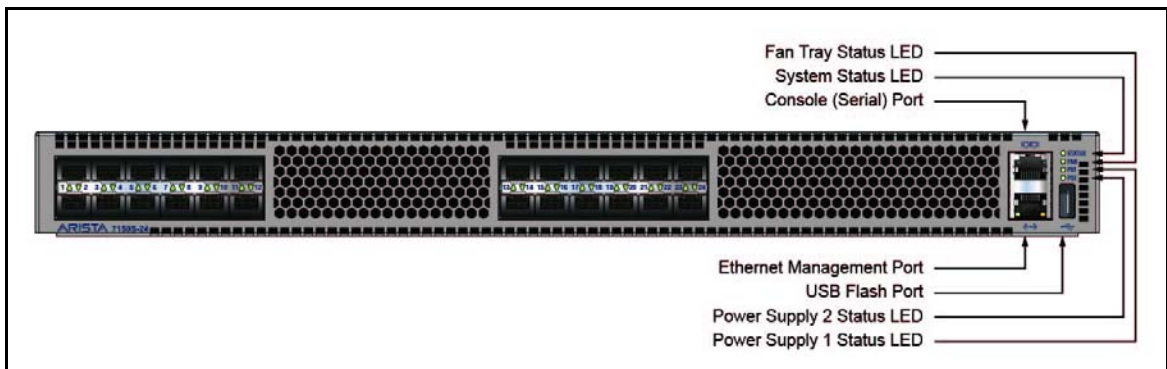

Figure 34: DCS-7150S-24 Front Panel

DCS-7150S-52

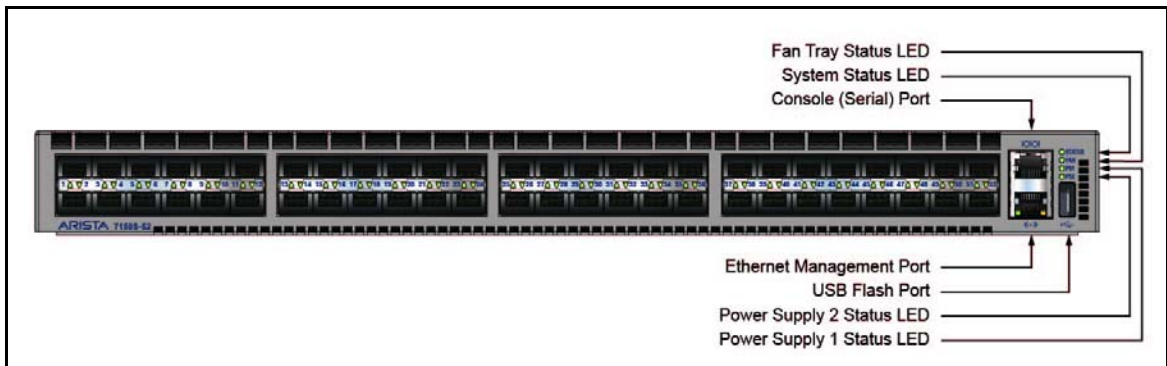

Figure 35: DCS-7150S-52 Front Panel

DCS-7150S-64

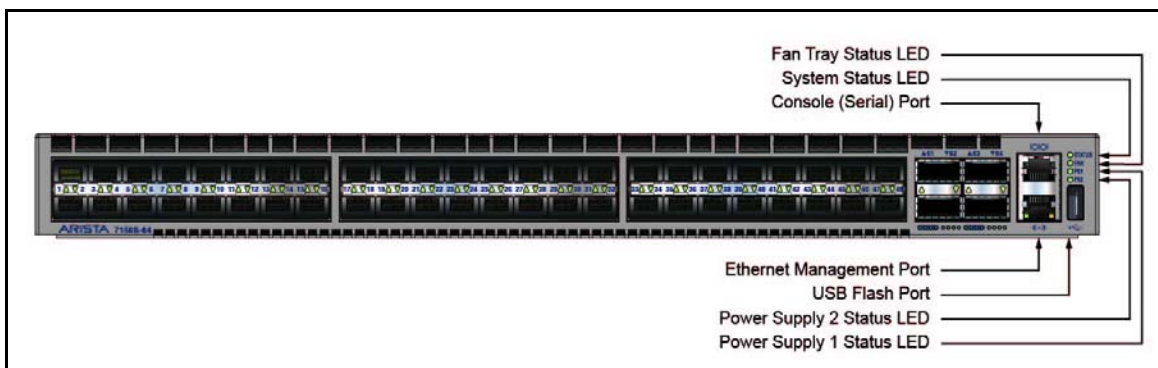

Figure 36: DCS-7150S-64 Front Panel

# Appendix D Rear Panel

This appendix displays the rear panel of all switches covered by this guide.

## All Models

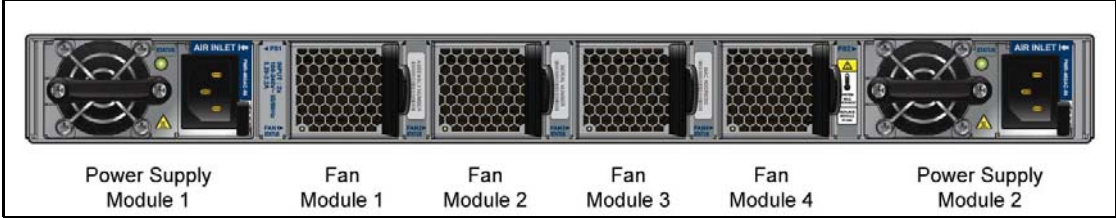

Figure 37: Rear Panel