

**SHORELINE**™  
LEISURE PRODUCTS

**HOT TUB  
OWNER'S  
MANUAL**

**2001**

# TABLE OF CONTENTS

Important Safety Instructions .....	3
Location and Installation .....	4
Hot Tub Set Up .....	5
Hot Tub Operation .....	6
Hot Tub Care and Maintenance .....	8
Winterizing .....	9
Water Care .....	10
Ozone .....	11
GFCI Load Center Wiring .....	12
Troubleshooting .....	13
Hot Tub and Dealer Information.....	15
Warranty .....	16



# **IMPORTANT SAFETY INSTRUCTIONS**

When installing and using this electrical equipment, basic safety precautions should always be followed, including the following:

**1. READ AND FOLLOW ALL INSTRUCTIONS.**

2. **WARNING-**To reduce the risk of injury, do not permit children to use this product unless they are closely supervised at all times.
3. A wire connector is provided on this unit to connect a minimum No. 8 AWG (8.4mm<sup>2</sup>) solid copper conductor between this unit and any metal equipment, metal enclosures of electrical equipment, metal water pipe, or conduit within 5 feet (1.5m) of the unit.
4. (For cord-connected/convertible units)  
DANGER-Risk of injury.
  - a) Replace damaged cord immediately.
  - b) Do not bury cord.
  - c) Connect to a grounded, grounding type receptacle only.
5. **WARNING-**If this product is provided with a ground-fault circuit-interrupter on the end of the power cord, the GFCI must be tested before each use. With the product operating, open the service door. If the product stops operating, this merely indicates that the door is equipped with an electrical interlock. Next, push the test button on the GFCI and close the service door. The product should not operate. Now open the service door, push the reset button on the GFCI and close the service door. The product should now operate normally. If the product fails to operate in this manner, there is a ground current flowing indicating the possibility of an electric shock. Disconnect the power until the fault has been identified and corrected.
6. **DANGER-**Risk of Accidental Drowning. Extreme caution must be exercised to prevent unauthorized access by children. To avoid accidents, ensure that children cannot use this hot tub unless they are supervised at all times.
7. **DANGER-**Risk of Injury. The suction fittings in this hot tub are sized to match the specific water flow created by the pump. Should the need arise to replace the suction fittings or the pump, be sure that the flow rates are compatible. Never operate the hot tub if the suction fittings are broken or missing. Never replace a suction fitting with one rated less than the flow rate marked on the original fitting.
8. **DANGER-** Risk of Electric Shock. Install at least 5 feet (1.5 m) from all metal surfaces. As an alternative, a hot tub may be installed within 5 feet of metal surfaces if each metal surface is permanently connected by a minimum No. 8 AWG (8.4 mm<sup>2</sup>) solid copper conductor to the wire connector on the terminal box that is provided for this purpose.
9. **DANGER-**Risk of Electric Shock. Do not permit any electric appliance, such as a light, telephone, radio, or television, within 5 feet (1.5 m) of a hot tub.
10. **WARNING-**To reduce the risk of injury:
  - a) The water in a hot tub should never exceed 40°C (104°F). Water temperatures between 38°C (100°F) and 40° C (104°) are considered safe for a healthy adult. Lower water temperatures are recommended for young children and when hot tub use exceeds 10 minutes.
  - b) Since excessive water temperatures have a high potential for causing fetal damage during the early months of pregnancy, pregnant or possibly pregnant women should limit hot tub water temperatures to 38° C (100° F).
  - c) Before entering a hot tub, the user should measure the water temperature with an accurate thermometer since the tolerance of water temperature-regulating devices varies.
  - d) The use of alcohol, drugs, or medication before or during hot tub use may lead to unconsciousness with the possibility of drowning.
  - e) Obese persons and persons with a history of heart disease, low or high blood pressure, circulatory system problems, or diabetes should consult a physician before using a hot tub.
  - f) Persons using medication should consult a physician before using a hot tub since some medication may induce drowsiness while other medication may affect heart rate, blood pressure, and circulation.

**11. SAVE THESE INSTRUCTIONS.**

# LOCATION AND INSTALLATION

Your Shoreline Leisure Products™ hot tub has been conveniently designed to be used in either an indoor or outdoor setting. While your hot tub was built to be used either indoors or outdoors, there are important things to remember in selecting your location.

## Indoor Use Only

- Humidity will not likely be a problem. However, just like in your bathroom, an exhaust fan would be a good idea.
- No matter how careful you are, you will splash water, especially when exiting the hot tub. We suggest a tile or vinyl floor.
- A self-draining floor is a great way to ease any worries about spilled water.
- Remember that you'll need extra space to store the cover when it is removed. When using our handy cover-lift device, you should allow for an extra 16" of clearance behind the hot tub.
- The hot tub must be placed on a flat and level surface that does not move or shake.
- You should consult with a builder or engineer to determine if your floor will support the hot tub weight. Remember, you must allow for the hot tub, water and people in your total weight calculations.
- Be sure your hot tub is secure from access to young children. Shoreline Leisure Products™ offers a locking hot tub cover, but we also suggest keeping the hot tub room locked and off limits to children.

## Outdoor Use Only

- Place your hot tub on a solid, flat surface. We recommend a 4" thick reinforced concrete pad as the *best* surface.
- Keep in mind natural elements such as wind, view, falling leaves, etc.
- We recommend that you locate your hot tub in a locked fenced-in area to prevent access to the hot tub by children.
- It is a good idea to have a contractor review your proposed site to see that there are no support problems.

## Indoor or Outdoor Use

- When installing the hot tub, provide for adequate drainage to prevent water from entering the equipment module area.
- When installing the hot tub, enable access to the equipment module compartment that is located behind the door opening.
- Never locate light switches or other electrical components within reach from inside your hot tub. The equipment module must remain protected by the cover of the hot tub equipment compartment.

Wherever you locate your hot tub, you will need to have access to water in order to fill it. Any water spigot or faucet will work. Also, you will need to be able to drain your hot tub periodically. Since your hot tub water will likely have chemicals in it, you won't want to drain your hot tub on the lawn or into a garden. Be sure you can reach a garden hose from the hot tub to where you plan to drain the water. Never let water get on the equipment module that is located inside the equipment compartment of your hot tub. Finally, we suggest that you consult an electrician prior to installation to be sure of power availability and cost.

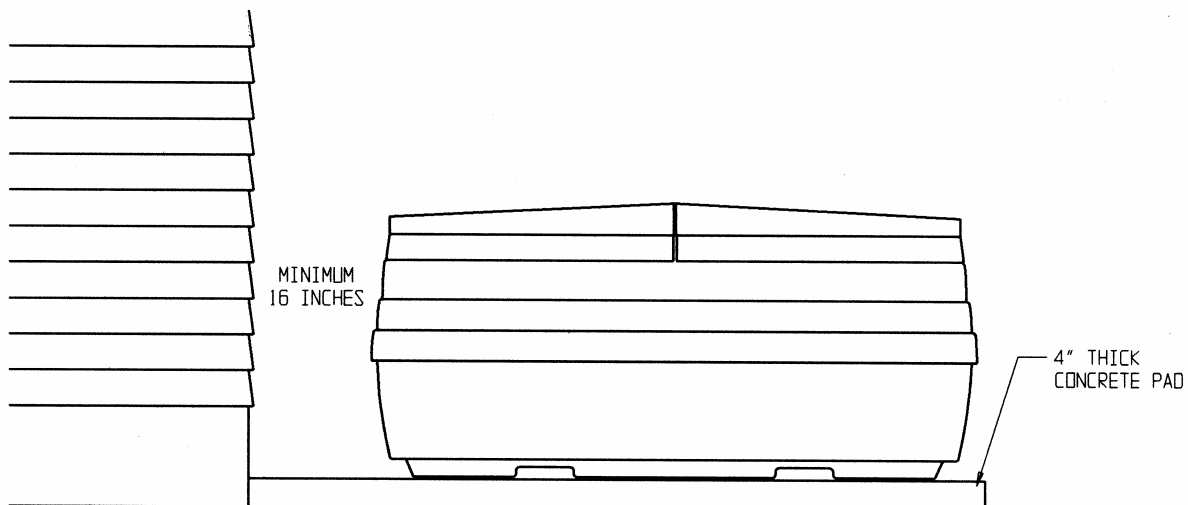

## RECOMMENDED SUPPORT

# HOT TUB SET UP

## **Unpacking**

1. Completely unwrap your hot tub and dispose of the packaging materials.
2. Remove any labels and tape that hold down various components within the hot tub.
3. Clean any dirt or dust from the interior of your hot tub with a damp cloth. Remove any stubborn stains with a mild, non abrasive liquid detergent. Never use an abrasive cleaner or scraper to clean the surface of your hot tub.
4. Position the cover on the hot tub and install the locking tabs to the outside of the hot tub (instructions included with cover).
5. Remove the cover of the equipment compartment to access the hot tub pump and control box. This cover is held in place with 4 screws.

## **Electrical**

Be sure your electrician reads this section and any others relating to the electrical hookup of your hot tub.

A multi-terminal bonding connector, located on the equipment module, is provided to permit connection of a bonding wire between this point and any accessible metal surface within 5 feet of the hot tub, as may be needed to comply with local requirements. The bonding wire connecting this bonding connector to the accessible metal surfaces must be a solid, No. 8 AWG copper conductor. This bonding connector may also be used to bond any field wired components.

All electrical connections to the equipment module must be accomplished by a qualified electrician in accordance with the National Electrical Code and in accordance with any local electrical codes in effect at the time of installation. All electrical connections must be made in accordance with the wiring information contained in this manual, or inside the field wiring access panel of the equipment module. National Electrical Code requires a Ground Fault Circuit Interrupter (GFCI) at the power source. All 230-volt models require an over-current protection device, GFCI, and minimum supply conductors rated at 50 amperes. Use copper conductors only. **WARNING:** Improper electrical connections or conductor sizing may cause the equipment module to operate improperly, create the potential for an electrical hazard, and may void the warranty. **CAUTION:** Use only approved pressure-type wire splicing lugs or connectors suitable for the size and type of wiring used.

**WARNING: Do not turn ON the power to the hot tub unless it is filled with water and all valves are open. Be sure water level is at the recommended point. If the power is ON, the system may start even though the controls were not activated. If the equipment module is started without sufficient water in the hot tub, the system could be permanently damaged. Also, operating hot tub without sufficient water could cause a fire.**

## **Filling Your Hot Tub**

Once the electric power has been connected, check the following while the power is OFF:

1. Be sure all fittings to the support system are tight. Hand tighten only!
2. Be sure the drain valve is closed.
3. Your hot tub is equipped with 2 push/pull valves. There is one located before the suction side of the pump and one located after the discharge side of your heater. Pull the push/pull valves OUT so they are open.
4. Using a garden hose, fill with water to 2-4" above the skim filter. Always fill your hot tub with hard (not softened) water. Place the end of the garden hose in the bottom of the tub, do not place hose into the skimmer filter. Do not overfill. After the hot tub is filled, remove the garden hose.
5. Check the equipment module area for water leaks. If there is water dripping, it is probably a loose connection at the equipment module. You should re-check the tightness of the fittings and placement of the "O"-rings. If you cannot locate the source of the water leak, contact your dealer.
6. Check that the filter is positioned in the skim/filter system. To remove, refer to the "Cleaning your filter" section.
7. Activate the power to your hot tub. Push the pump button on your controller until you hear the pump activate to HIGH speed. Allow the pump to run on HIGH speed for 2 minutes to purge the system of air, then push the pump button until you hear the pump switch to LOW speed.

# HOT TUB OPERATION

Refer to the Control Manual operating instructions for the hot tub-side control unit.

Your Shoreline Leisure Products™ hot tub comes equipped with a variety of jets and water/air controls. Some of the jets allow you to control the amount of water flow by rotating the face of the jet. Turning the face clockwise will reduce the water flow from the jet and turning it counterclockwise will increase the water flow. In addition, some of the jets perform special tasks.

## **Air Control**

Your hot tub comes equipped with an air control that is located on the top of your hot tub. If you turn the air control open (counterclockwise) when the pump is on high speed, air will be drawn through the Power Boost and Micro Swirl jets. The control regulates the airflow to the jets. Turn the air control counterclockwise while the pump is on high speed and you will see the jets produce added agitation. Turning the control clockwise will return the jets to water-only operation.



## **Power Boost Jets**

There are two types of Power Boost Jets, and they are interchangeable. Simply turn the outer ring counterclockwise past the stop point. This disengages the jet, then gently pull on the outside ring of the jet. The jet insert will pull away from the hot tub. Follow the same procedure with another jet. You can customize your massage by switching the jets in your hot tub. To reinstall, simply push the jet insert back into the jet cavity until it stops, then rotate the jet clockwise until it snaps into place. Water flow through these jets can be controlled by turning the outside face of the jet. Turning the trim ring clockwise will reduce the water flow from the jet and turning it counterclockwise will increase the water flow.



## **Ozone Jet**

In the foot well of your hot tub there is a small jet which allows ozone to be drawn into your hot tub. With an ozonator installed, there will be a steady stream of small air bubbles coming from the ozone jet whenever the hot tub pump is in operation. Your hot tub is manufactured "ozone ready", or plumbed to accept an ozonator should you decide to add one. Please refer to the Ozone section on page 11 of this manual.





**Micro Swirl Jets**

Water flow through these jets can be controlled by turning the outside face of the jet. Turning the trim ring clockwise will reduce the water flow from the jet and turning it counterclockwise will increase the water flow.



**Soft Spray Jet**

This grouping of jets is designed to give a soft massage over a larger area of your back. These are also used as foot jets in the footwell of your hot tub.

**Hot Tub Light**

Red and blue colored light lenses are included with your hot tub. To install or remove lenses simply push them on or pull them off from the light on the inside of the hot tub.



To replace the hot tub light bulb, turn off all power to the equipment module. Locate the rear of the hot tub light assembly and unscrew the lamp holder from the clear lens body. Pull the bulb from the socket and replace by reversing the above steps. CAUTION: The replacement bulb must be the same rating as the factory installed bulb (standard automotive type #912).

# HOT TUB CARE AND MAINTENANCE

## Draining Your Hot Tub

Under normal usage, you should change the water in your hot tub every 3-4 months. To drain hot tubs equipped with the Quick Drain System, first turn off electrical power to your hot tub. Unscrew the round cap in the center of the quick drain and attach a garden hose. Turn the outer ring (or valve) 1/2 turn counterclockwise and pull it toward you to open it. To close, push it in and turn it clockwise 1/2 turn.

The remaining water in the hot tub can be scooped or sponged out and you are now ready to clean the ABS plastic surface. Note: It is recommended that you not drain water onto grass or vegetation since chemicals in the hot tub water may damage them.



## Cleaning The Hot Tub Surface

Your Shoreline Leisure Products™ hot tub is manufactured with a premium grade weatherable ABS. The quality finish is durable and easy to clean and maintain. When the hot tub is empty, you can clean the surface by using a mild, non-abrasive liquid detergent, or specially formulated hot tub cleaner. Thoroughly remove all residue from the cleaning agent prior to refilling the hot tub. Do not use an abrasive brush or cleaning agent, as it will scratch the ABS finish. If you have stubborn dirt or scum marks at the water line, use a hot tub cleaner and a scrub pad designed for use on plastic surfaces, which are available at your local hot tub dealership.

## Power Boost and Micro Jets

The interchangeable Power Boost and Micro Jet inserts should be removed from time to time to clean off any accumulated hair, dirt deposits, etc. This will insure proper operation of the water flow control feature.

## Thermal Hot Tub Cover

It is important that you properly care for your hot tub cover. Do not sit or stand on the cover, as it will break. Do not let snow build up on your cover. Locking tie-down straps are included with your cover and should be used to prevent access to the hot tub by children. They will also help to prevent the wind from lifting the cover off your hot tub. If your hot tub is located outdoors, it is important that the cover be installed on the hot tub even if the tub has been drained. This will protect the hot tub shell from the intense heat of the sun. Periodically clean your cover as described in the maintenance and cleaning instructions provided with the cover. When handling your cover, take care not to drag it over rough surfaces that will scuff or tear the fabric. Always lift by the handles or use the cover lift device which is available from your Shoreline Leisure Products™ dealer.



## Hot Tub Exterior Care

The hot tub exterior is made of a specially formulated polyethylene plastic. It is very resistant to scratching and denting and can be cleaned with a mild detergent or vinyl siding cleaner.



# WINTERIZING

If you live in an area where the danger of freezing exists, you must take extra precautions to insure that your hot tub will operate properly. If you plan to operate your hot tub throughout the winter, be sure that the thermostat is set to keep the water warm. If you intend on closing down your hot tub for the winter, you should follow the winterizing procedures listed below:

1. Drain the hot tub as explained in the "Draining Your Hot Tub" section.
2. Be sure that all water is removed from the hot tub.
3. Shut off all electrical power at the breaker box.
4. Disconnect the unions from the equipment module to allow the water in the hot tub lines and equipment module to drain.
5. Remove the drain plug on the pump housing to allow water to drain out of the pump. Replace the drain plug.
6. Open all air controls to allow trapped water to drain through jets.
7. Remove the filter element from the filter housing and see that the filter housing is dry. If water is left in the filter housing it will freeze and cause the housing to crack.
8. Using a wet/dry shop vac, vacuum out each of the lines at the point where you disconnected the unions from the equipment module. Also, put the vacuum hose up against the face of each jet opening to vacuum out any water remaining in their supply lines.
9. Cover your hot tub with your hot tub cover and be sure it is locked in place.

WARNING: Failure to maintain the proper chemical levels or properly winterize your hot tub may cause extensive damage to components. Damage to components or the hot tub shell itself resulting from improper chemical maintenance or improper winterization will NOT be covered under warranty.

# WATER CARE

## Filter and Basket Change Procedure

1. Turn off electrical power to the hot tub.
2. Remove the floating weir and attached basket by turning counter clockwise to align the flats and lift out in one piece.
3. Lift the filter cartridge straight out of the filter housing.
4. Clean the filter cartridge (see instructions).
5. Separate the basket from the floating weir adapter by spreading the raised edge of the basket away from the floating weir tab.
6. Clean the basket. Avoid hitting the basket against objects to knock debris loose, as this will break the basket.
7. Re-attach the basket to the floating weir. Line up the tabs from the basket to indents in the floating weir and gently snap into place.
8. Replace the cleaned filter cartridge by placing it back in the filter housing.
9. Replace the floating weir and attached basket assembly by lining up the flats and turning clockwise.
10. Turn electrical power back on.



## Cleaning the Filter Cartridge

Your Shoreline Leisure Products™ hot tub is equipped with what we believe is the finest filtering device available. We call it the Skim/Filter system, and it is one of the few skimmers available which actually skims the water surface. When your hot tub is operating, watch how the Skim/Filter bobs up and down with the water level. You'll notice a distinct whirlpool being drawn into the system, and floating debris of all sizes will literally "fall" into the unit and be trapped by the filter. It is important that you keep your filter clean, and it is suggested that you clean the filter at least once per month. To clean your filter:

1. Remove the filter cartridge according to the previous instructions.
2. With a garden hose and nozzle or other high-pressure device, spray the cartridge clean with a jet stream of water. Work top to bottom on each pleat. To remove collected suntan lotions and body oils that the spray will not remove, soak the cartridge in a plastic container for at least an hour (overnight is ideal) using a commercial filter cleaner, a cup of trisodium phosphate in five gallons of water, or a cup of dishwasher detergent in five gallons of water.
3. If the filter is coated with algae, calcium carbonate, or minerals, soak it in a solution of one part muriatic acid to 20 parts water until the solution stops bubbling. **WARNING:** Failing to remove oils and cleaning solution before acid soaking will permanently restrict the water flow and ruin the filter prematurely.
4. Rinse again to remove oils and cleaning solution. Reinstall the cartridge and the floating weir/basket assembly.

## Chemicals

Due to the warm temperatures in your hot tub, you should properly test and maintain your hot tub water for health and appearance reasons. Chemical imbalance can cause skin irritations, and dirty water is both unsightly and undesirable to soak in. With little effort you can have clean water for your constant enjoyment. This is attained through the use of hot tub chemicals, a superb filter system and the optional ozonator. Consult your dealer to set up a proper water treatment program that will best work with the equipment in your hot tub. Be aware that the mineral content of hot tub water increases from water evaporation and with the addition of algaecidal and sanitizing chemicals. If the mineral concentration of the water becomes too high, the minerals will precipitate and deposit on the hot tub, in the filter, and on the heater. The water must be changed when the amount of dissolved solids becomes excessive. Algaecidal and sanitizing chemicals are either alkaline or acidic. Sodium and calcium hypochlorite are alkaline. Chlorine gas and practically all other dry chlorine products are acidic. Whichever type of chlorine is used, it is very important that the pH level be checked frequently and maintained between 7.2 and 7.8.

**CAUTION:** Do NOT store hot tub chemicals near the equipment module because their corrosive fumes may cause damage. Change the hot tub water frequently, typically every 3 to 4 months or when the water clarity and cleanliness can no longer be maintained by chemical treatment. It is recommended that the total alkalinity of the hot tub water be kept from 80 to 100 parts per million (ppm) when sodium or calcium hypochlorites are used, and 100 to 120 ppm when other dry chlorine products are used.

# OZONE

The ozonator is a unit that contains an ultra-violet light. When the unit is activated, ozone is generated which is drawn into the hot tub via the ozone jet. The ozone gas appears as tiny bubbles that come from the ozone jet which is located near the front of the hot tub. The ozone coming into your hot tub purifies the water without the skin irritation and chemical smell that can occur with the use of chemicals. The ozone unit operates when the equipment module is in the filtering mode.

Ozone is a gas which occurs in nature. The ultraviolet (UV) radiation from the sun creates ozone photochemically in the outer limits of the atmosphere. Ozone is also created near ground level by lightning during electrical storms. Ozone generators simulate the short wavelength ultraviolet radiation of the sun.

Oxygen molecules ( $O_2$ ) contained in the air passing through the ozone generator are energized and split into single oxygen atoms ( $O_1$ ). These  $O_1$ 's are highly reactive and combined with additional  $O_2$  form Ozone ( $O_3$ ). This photochemical method of producing ozone is safe and efficient.

Ozone has proven to be a very effective supplement for conventional chemicals to provide cleaner, healthier water and to significantly reduce undesirable chemical by-products.

## GFCI LOAD CENTER WIRING

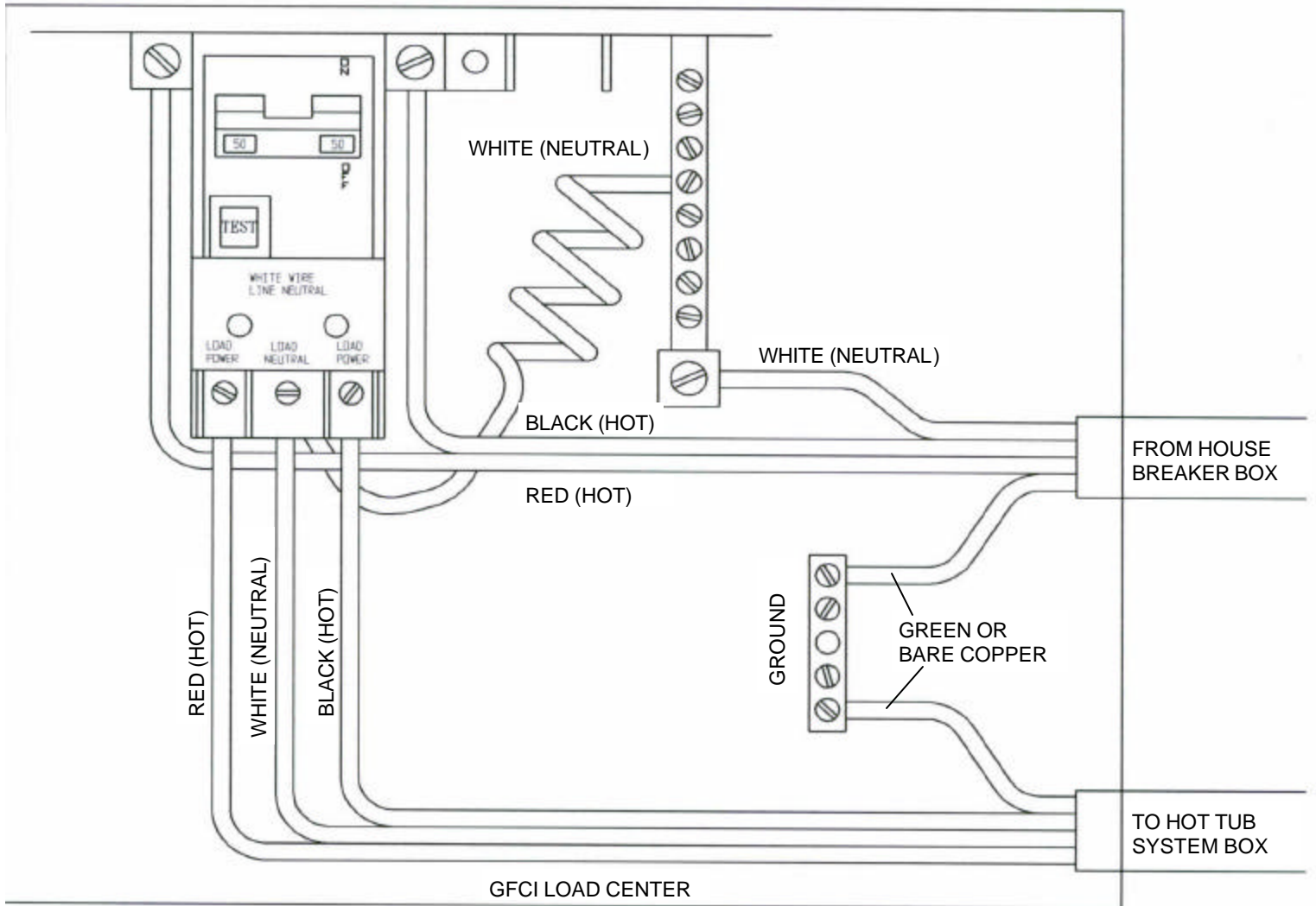

### NOTE:

The white neutral wire from the back of the GFCI MUST be connected to an incoming line neutral. The internal mechanism of the GFCI requires this neutral connection. The GFCI will not work without it.

Use a 50 amp 240 volt 4-wire GFCI circuit breaker for all Shoreline Leisure Products™ hot tub 240 volt models.

### IMPORTANT NOTE:

Installation of this GFCI-Circuit Breaker, including ampere sizing and selection of conductor size and type, must be accomplished by a qualified electrician in accordance with the National Electrical Code, or the Canadian Electrical Code, and all federal, state and local codes and regulations in effect at the time of installation.

# TROUBLESHOOTING

- **Equipment Module Will Not Operate**

- Make sure the hot tub control panel is plugged into the circuit board of the equipment module.
- Check the main circuit breaker panel. If the GFCI or circuit breaker has tripped, reset the breaker. If the circuit breaker trips repeatedly, contact your dealer.
- Turn the circuit breaker, or switch, supplying power to the equipment module OFF then ON.
- If breaker continues to trip, check with your electrician to be sure the proper amperage breaker was installed.

- **Pump Will Run But There Is No Water Flow**

- Make sure all valves are in the open position.
- Make sure the filter is clean.
- Make sure the suction intake covers are free of debris.
- Make sure the water level of the hot tub is at least 2" above the skim filter.
- Check to make sure all adjustable flow-type jets are turned open.

- **Pump Runs And There Is Water Flow But No Heat**

- Press the temperature set button to increase temperature. Do NOT expect to feel hot water coming from the jets.
- Make sure all valves are open to allow full water flow through the system. Limited water flow will NOT build enough pressure to allow the heater to come on.
- Clean the filter to assure maximum water flow.
- The system is equipped with a heater delay switch that will prevent heater operation from occurring for approximately 20 seconds after the pump starts. Make sure the pump has been operating for at least 20 seconds.

- **Pulsating Or Minimal Water Flow In High Speed Mode**

- Make sure water level of the hot tub is at least 2" above the skim filter.
- Be sure jets are turned open (see "Operation" section).
- Make sure all valves are open.
- Make sure the filter element is clean.
- Make sure the suction intake cover is free of debris.

- **Pump Vibrates Excessively**

- Check for loose fasteners on the equipment module.
- Make sure hot tub is not touching or rubbing against anything such as a deck rail, house, etc.
- Make sure that the hot tub has been installed on a properly supported surface.



## *Thank You!*

The employees of GPM Industries would like to extend their sincere thanks to you for purchasing a Shoreline Leisure Products™ hot tub.

We hope that you, your family, and friends will experience many enjoyable years of fun and relaxation in your new hot tub.

Please fill in the following information, it will be very important should you ever have questions or concerns regarding your hot tub.

**Your Shoreline Leisure Products™ Dealer**

Dealership \_\_\_\_\_  
Address \_\_\_\_\_  
City \_\_\_\_\_ State \_\_\_\_\_ ZIP \_\_\_\_\_  
Phone \_\_\_\_\_ Fax \_\_\_\_\_  
E-mail \_\_\_\_\_  
Contact Person \_\_\_\_\_

**Your Hot Tub**

Model Purchased \_\_\_\_\_  
Date Purchased \_\_\_\_\_  
Serial Number \_\_\_\_\_  
Colors  
Hot Tub Shell \_\_\_\_\_  
Exterior \_\_\_\_\_  
Cover \_\_\_\_\_

**Notes:**

\_\_\_\_\_  
\_\_\_\_\_  
\_\_\_\_\_  
\_\_\_\_\_  
\_\_\_\_\_  
\_\_\_\_\_  
\_\_\_\_\_  
\_\_\_\_\_  
\_\_\_\_\_  
\_\_\_\_\_

# SHORELINE® HOT TUB

## LIMITED WARRANTY

GPM Industries, Inc. ("GPM") extends this Limited Warranty solely to the original consumer purchaser of any Shoreline Hot Tub manufactured and installed in the U.S.A. after April 15, 2001.

### **FIVE YEAR SHELL WARRANTY**

GPM warrants the formed shell against water loss due to cracking, chipping or deterioration due to manufacturing defects for a period not to exceed the lesser of five (5) years from the date of purchase or five (5) years six (6) months from the date of manufacture.

### **FIVE YEAR EXTERIOR WARRANTY**

GPM warrants the structural integrity of the formed exterior against manufacturing defects for a period not to exceed the lesser of five (5) years from the date of purchase or five (5) years six (6) months from the date of manufacture.

### **TWO YEAR COMPONENT WARRANTY**

GPM warrants the mechanical equipment, plumbing, fittings, and controls against defects in workmanship for a period not to exceed the lesser of two (2) years from the date of purchase or two (2) years six (6) months from the date of manufacture. Damage caused due to improper electrical hook-up or wiring voids the warranty. Travel, trip, or mileage costs are not covered under this warranty and service travel charges will be assessed to the purchaser.

### **EXTENT OF WARRANTY.**

This warranty extends only to the original "consumer" purchaser of the Shoreline Hot Tub as that term is defined in the Magnuson-Moss Warranty Act, 15 USC Section 101, as amended. Use of the hot tub for rental, public or any commercial application of any kind voids this warranty. Warranty coverage shall not extend for any reason beyond the stated periods. This warranty terminates upon transfer of ownership.

### **WARRANTY PERFORMANCE.**

In the event of any malfunction or defect covered by this warranty, contact the authorized Shoreline Dealer from whom you purchased your hot tub. All service work must be performed by an authorized Shoreline Dealer or an authorized agent of GPM. In the event there is not an authorized GPM Dealer or repair firm in your area, the hot tub or equipment must be returned pre-paid freight (you pay) to GPM for repair of the defect. GPM will then ship the hot tub back to you pre-paid (GPM pays) upon completion of the repair. In the event the hot tub or any component needs to be returned to GPM for repair, contact GPM in advance at: 423 West 22nd Street, Holland, Michigan 49423, phone number: (616)392-5947, for packaging and shipping instructions. In addition, GPM reserves the right to inspect or designate a person to inspect any part that is claimed to be defective and covered by this warranty. For any warranty service of components, GPM reserves the right to choose at its option repair of the problem or a replacement of the defective component. The purchaser is responsible to provide adequate access to the hot tub, equipment and plumbing.

### **ACTS INVALIDATING WARRANTY.**

This warranty is void if the GPM hot tub has been subject to alteration, misuse or abuse, or if any repairs on the hot tub are attempted by anyone other than an authorized representative of GPM. Alteration shall include but is not limited to any component or plumbing change, electrical conversion, or the addition of any non-approved sanitation or water purification device or heating system which contributes to a component or unit failure or unsafe operation system. Use of the hot tub in an application for which it is not designed will void this warranty. This includes but is not limited to damage caused by operation of the hot tub at water temperatures outside the range of 50 degrees F. and 104 degrees F., damage caused by dirty, clogged or calcified filter cartridges, damage caused by a defective Support System or other defective components, damage to the hot tub surface caused by harsh chemicals which are not recommended by the manufacturer, damage caused by allowing un-dissolved hot tub sanitizing chemicals to lie on the hot tub surface, damage to components or hot tub surface caused by improper water chemistry maintenance, damage caused to the hot tub by leaving it uncovered in direct sunlight, damage caused by leaving the hot tub in freezing conditions, and damage to the hot tub surface caused by movement of the product, and damage to the hot tub caused by acts of God. This product is not designed or intended for commercial use.

### **DISCLAIMERS.**

**Any implied warranties arising out of an original purchaser's purchase of a Shoreline hot tub, including but not limited to the implied warranties of merchantability and fitness for a particular purpose, are limited in duration equal to the duration of the applicable warranty stated above. GPM shall not be liable for loss of use of the GPM hot tub or other incidental or consequential costs, expenses or damage, which may include but are not limited to, the removal of or reinstallation of a wall, deck or other fixture, water leakage, costs of shipping or packaging, applicable taxes, or the payment of any costs or expenses of disassembly, removal, or reinstallation of the product or any part. Under no circumstances shall GPM or its representatives be held liable for injury to any person or damage to any property, however arising, even if caused by GPM or its representatives' negligence. Some states do not allow limitation on how long an implied warranty lasts, and some states do not allow the exclusion or limitation of incidental or consequential damages, so these limitations or exclusions may not apply to you. These warranties give you specific legal rights, and you may also have other rights which vary from state to state. **No distributor, salesperson, dealer, retailer, or other representative of GPM has the authority to alter or change these warranties either orally or in writing.****