

Canon



Photo Printer

PIXMA

iP6320D/iP6310D Series

Quick Start Guide



Getting Help from Canon

Help Us Help You Better

Before you contact Canon, please record the following information.

Serial Number (located on the inside of the product): _____

Model Number (located on the top of the product): _____

Setup CD-ROM number (located on the CD-ROM): _____

Purchase Date: _____

Customer Technical Support Sequence*

1. Internet — www.canontechsupport.com

For quick and comprehensive self-help in an intuitively guided interactive troubleshooting environment, the place to start is our helpful tech support web site. In addition, the latest driver downloads, answers to frequently asked questions, product information, and “where to buy” instructions are found here.

2. Email Tech Support — www.canontechsupport.com

For individual attention to a special issue, try emailing our friendly technical support representatives, specially trained to communicate quick, easy, and logical solutions to your inquiries within 24 hours.

3. Toll-Free Live Tech Support — (1-800-828-4040)

This option provides live telephone technical support, free of service charges, Monday-Saturday (excluding holidays), during your product's 1 year limited warranty period. Telephone Device for the Deaf (TDD) support is available at **(1-866-251-3752)**.

4. Extended Service and Support — www.canonesp.com

Canon CarePAK Extended Service Plan is a cost-attractive and easy-to-use extended service program that provides up to three full years of service and support coverage at a very attractive price. CarePAK offers toll-free Canon technical support and includes Canon's superb InstantExchange product replacement program. For further information about extending your Canon service and support, call (1-800-385-2155), or visit our Web site at **www.canonesp.com**. CarePAK must be purchased during your product's warranty period.

For more information and updated program specifics, please visit our web site at **www.canontechsupport.com**.

* Support program specifics are subject to change without notice.

Canon

PIXMA
iP6320D/iP6310D

Photo Printer

Quick Start Guide

Canon PIXMA iP6320D/iP6310D Photo Printer Quick Start Guide

The diagrams and computer screens in this guide refer to the iP6320D. The operations are the exactly the same with the iP6310D, unless otherwise described.

Copyright

This manual is copyrighted by Canon U.S.A., Inc. with all rights reserved. Under the copyright laws, this manual may not be reproduced in any form, in whole or in part, without the prior written consent of Canon U.S.A., Inc.

© 2006 Canon U.S.A., Inc.

Disclaimer

Canon U.S.A., Inc. has reviewed this manual thoroughly in order that it will be an easy-to-use guide to your Canon PIXMA iP6320D/iP6310D Photo Printer. All statements, technical information and recommendations in this manual and in any guides or related documents are believed reliable, but the accuracy and completeness thereof are not guaranteed or warranted, and they are not intended to be, nor should they be understood to be, representation or warranties concerning the products described.

Specifications are subject to change without notice.



As an ENERGY STAR partner, Canon U.S.A., Inc., has determined that this product meets the ENERGY STAR guidelines for energy efficiency.

All information regarding non-Canon products was compiled from publicly available information. No representation is made regarding the accuracy thereof.

About Consumables

Consumables (ink tanks / FINE cartridges) are available for 5 years after production has stopped.

Trademarks

- "Windows" and "Internet Explorer" are trademarks of Microsoft Corporation, registered in the United States and other countries.
- "Macintosh" and "Mac" are trademarks of Apple Computer, Inc., registered in the U.S. and other countries.
- "SmartMedia" is a trademark of Toshiba Corporation.
- "MEMORY STICK", "Memory Stick PRO", "MEMORY STICK Duo" and "Memory Stick PRO Duo" are trademarks of Sony Corporation.
- "xD-Picture Card" is a trademark of Fuji Photo Film Co., Ltd.
- "MultiMediaCard" is a trademark of Infineon Technologies AG.
- "SD card" and "miniSD Card" are trademarks of SD Association.
- "IrDA Feature Trademark" is owned by the Infrared Data Association and used under license therefrom.
- "Bluetooth" is a trademark of Bluetooth SIG, Inc., U.S.A. and are licensed to Canon Inc.
- "Adobe" and "Adobe RGB (1998)" are either registered trademarks or trademarks of Adobe Systems Incorporated in the United States and/or other countries.

Canon U.S.A., Inc.
One Canon Plaza
Lake Success, NY 11042

Bluetooth ID: B02165

Contents

Basic Printing

Turning on the Printer	2
Turning off the Printer	3
Loading Paper	4
Using Specialty Media	9
Printing with Windows	11
Printing with Macintosh	13
Cancel Printing	15
Accessing the Printer Driver (Windows)	16
Using the Bundled Software.....	17

Printing Maintenance

When Printing Becomes Faint or Colors are Incorrect	18
---	----

Troubleshooting

Cannot Install the Printer Driver.....	20
Cannot Connect to PC Properly	21
Print Quality is Poor or Contains Errors	22
Printer Does Not Start or Stops During Print Jobs	25
Paper Does Not Feed Properly	26
Paper Jams	26
An Error Message Appears on the Screen	27
POWER Lamp and Alarm Lamp Flash Alternately	28

Appendix

Specifications	29
Safety Precautions	32
Regulatory Information	34
CANON U.S.A., INC. LIMITED WARRANTY --- (USA Only)	35

Index	37
--------------------	----

Basic Printing

 **Note** This *Quick Start Guide* describes some of the features of your printer and how to use them. For more information, view the *iP6320D/iP6310D User's Guide*, *Printer Driver Guide*, and *Photo Application Guide* installed on your computer, or use the online help within your printer driver interface:

Windows

While in the printer's properties dialog box, press the **F1** key, or click  in the upper right corner. Then click the feature you want to know more about, or click the **Help** button when displayed.

Macintosh

While in the **Page Setup** dialog box or **Print** dialog box, click  in the lower left corner.

Clicking  provides detailed information about each setting. When the Help window appears, select your desired topic.

Turning on the Printer

1 To turn on the printer, press the **POWER** button.

The **POWER** lamp flashes while the printer warms up and changes to steady (non-flashing) when the printer is ready.

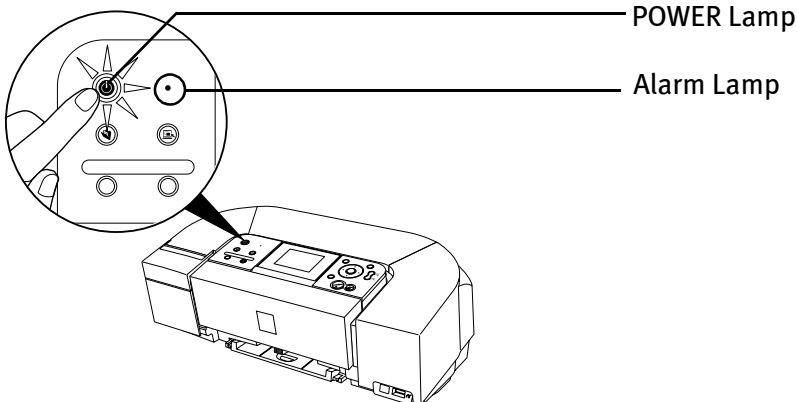

-  **Important**
- If the **Alarm** lamp lights, refer to “An Error Message is Displayed on the LCD” in the “Troubleshooting” section of the *Direct Printing Guide*.
 - If the **POWER** lamp and the **Alarm** lamp flash alternately, see “**POWER Lamp and Alarm Lamp Flash Alternately**” on page 28.

Turning off the Printer

- 1 To turn off the printer, press the **POWER** button.

When the **POWER** lamp stops blinking, the printer is turned off.

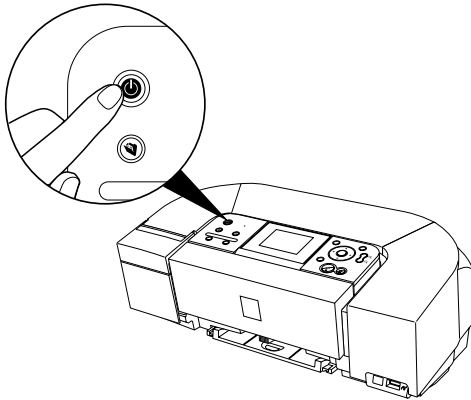

Important About the Power Plug

When removing the power plug after turning off the printer, be sure to check that the **POWER** lamp is not lit. If the power plug is removed from the wall outlet with the **POWER** lamp lit or blinking, the printer cannot protect its print heads and may be unable to print.

Loading Paper

■ Print Media to Avoid

Do not use the following types of paper. Using such paper will not only produce unsatisfactory results, but can also cause the printer to jam or malfunction.

- Folded, curled or wrinkled paper
- Damp paper
- Paper that is too thin (less than 64 gsm/17 lb)
- Paper that is too thick (more than 105 gsm/28 lb)*
- Paper with holes
- Picture postcards
- Postcards with an affixed photo or sticker
- Envelopes with double flaps
- Envelopes with pressure seals
- Envelopes with an embossed or treated surface

*Non-Canon genuine paper

Also, do not use a cut paper or memo pad, when printing on a paper smaller than A5 size.

■ Preparing the Printer

-  **Note**
- For detailed information on the specialty media Canon provides for use with its various printers, see “**Using Specialty Media**” on page 9.
 - Consult “**Printing Media**” in the *User's Guide* for detailed instructions on how to load specialty media into the printer.

1 Flatten the four corners of the paper before loading it.

-  **Note** When paper is curled, gently bend it in the opposite direction of the curl (without curling the reverse side) and then load the paper. How to flatten paper curl, refer to “**Paper is curled**” on page 24.

2 Prepare to load paper.

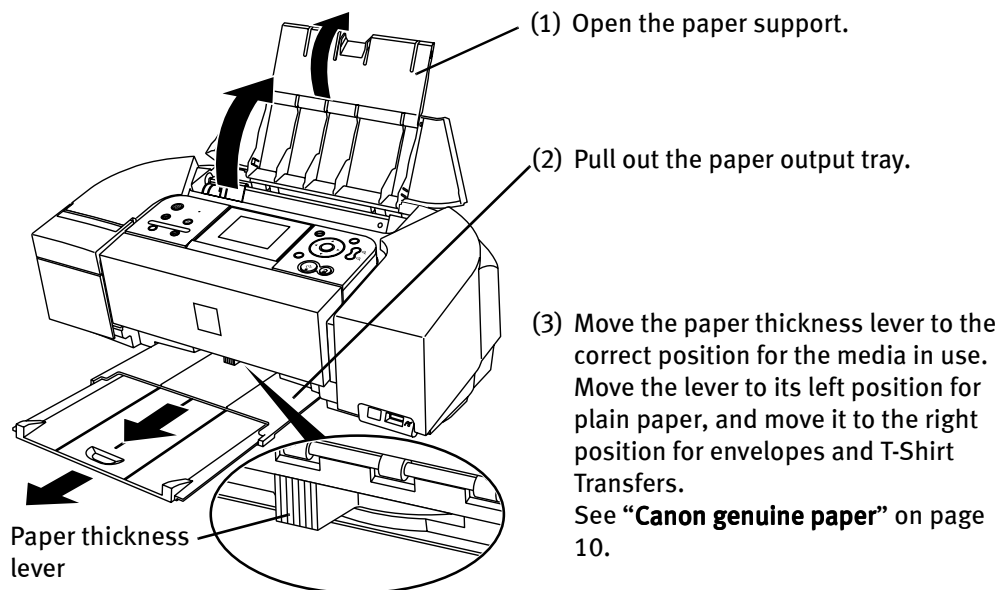

-  **Note**
- Place the printer on a flat surface.
 - Do not place any obstacles in front of the printer to keep this area open for paper which is ejected.
 - Remove each sheet as soon as paper is ejected. If the paper output slot is stacked with printed sheets it may interfere with the printer's ejecting process.
 - When performing duplex printing, pay great attention to the dust and stain on the area (desk, etc.) where the printed paper is ejected. Printing with dust and stain remaining on this area can have a bad effect on the printing result and printer.

3 Load the paper.

■ Loading Plain Paper

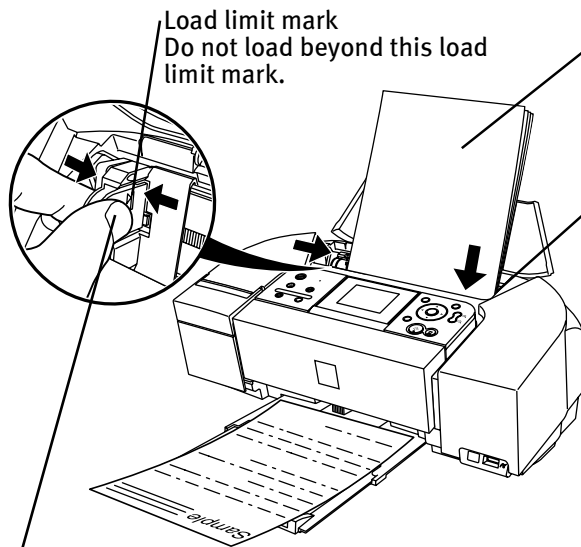

Load limit mark
Do not load beyond this load
limit mark.

- (1) Insert the paper into the auto sheet feeder with the print side facing up. When loading the 4" x 6" paper, load sheets in the portrait position (short side facing down).
- (2) Align the paper stack against the right side of the auto sheet feeder.

- (3) Pinch the paper guide and slide it against the left side of the paper stack.



Note

- You can use general copy paper or Canon's Super White Paper.
- You can load up to 100 sheets of plain paper (64 gsm or 17 lb, 10 mm or 0.39 inches in height) in the auto sheet feeder.
- Do not touch the printed surfaces until the ink dries. For specific drying times, refer to the instructions packaged with your media.

■ Loading Envelopes

Use either European DL or US Comm. #10 size envelopes.

The address is automatically rotated and printed out.

- Important**
- Do not use envelopes with embossed or treated surface, with a double flap or pressure seals, with sticker flaps.
 - Select either **DL Env.** or **Comm. Env. #10** in the printer driver according to the envelope size you are using.
 - If you do not select **Media Type** correctly, the print out results in the wrong way round.

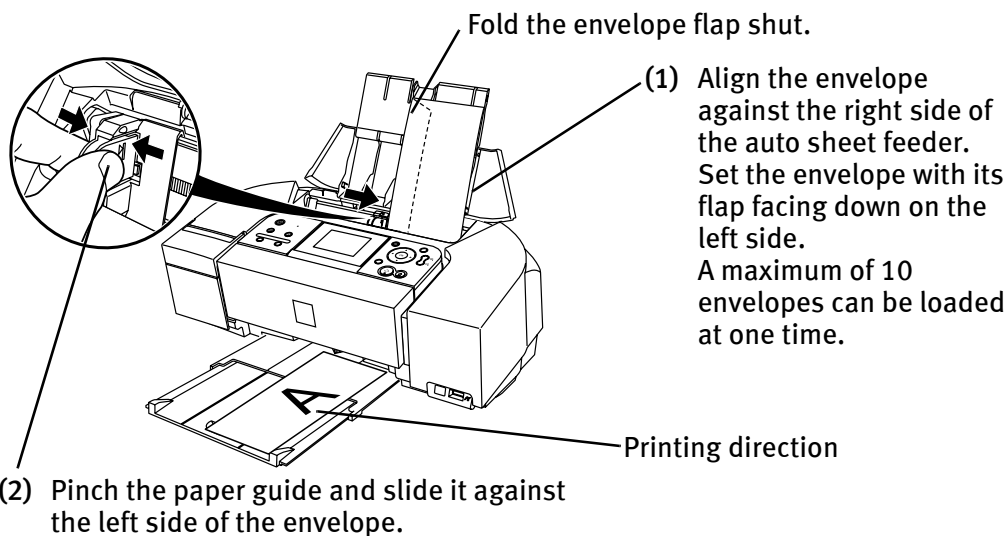

- Note**
- When printing the envelope, set the paper thickness lever to the right.
 - When using a special paper to inverse the print result, open the printer properties dialog box and select the **Rotate 180 degrees** check box on the **Page Setup** tab.

- (3) Select **Envelope** in **Media Type**, and then select **DL Env.** or **Comm. Env. #10** in **Page Size**.
- (4) Select **Landscape** in **Orientation**.

For the printer driver setting, see “**Printing with Windows**” on page 11, or “**Printing with Macintosh**” on page 13.

■ Loading Other Small-Sized Paper

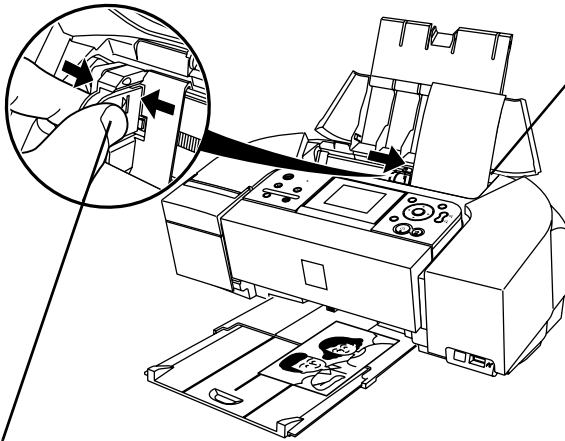

(1) Align the paper against the right side of the auto sheet feeder. Regardless to the actual orientation of your photograph, load the paper vertically (short side first) in the printer. A maximum of 20 sheets of size in 4" x 6" paper can be loaded at one time.

(2) Pinch the paper guide and slide it against the left side of the paper stack.

(3) Select **4x6in 101.6x152.4mm**, **5x7in 127.0x177.8mm** or **Credit Card 2.13x3.39in 54x86mm** from **Page Size** in the printer driver.

For the printer driver setting, see “**Printing with Windows**” on page 11, or “**Printing with Macintosh**” on page 13.

Important Always load paper in portrait orientation. Loading paper in landscape orientation can cause the paper to be jammed.

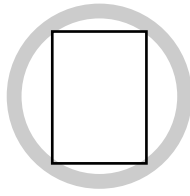

Portrait

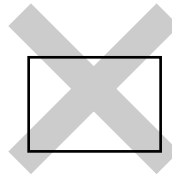

Landscape



Note We recommend using Canon photo media when printing photographs. See “**Using Specialty Media**” on page 9.

Using Specialty Media

Canon recommends that you use Canon genuine paper to ensure optimal print quality.

■ Photo Quality Media

- Glossy Photo Paper
- Matte Photo Paper
- Photo Paper Plus Double Sided
- Photo Paper Plus Glossy
- Photo Paper Plus Semi-Gloss
- Photo Paper Pro
- Photo Stickers



■ Media for Business Documents

- High Resolution Paper

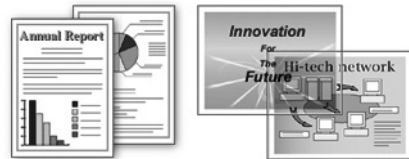

■ Canon genuine paper

Media Name	Paper Support Load Limit	Paper Thickness Lever Position	Printer Driver Settings for Media Type
High Resolution Paper	Letter: up to 80 sheets	Left	High Resolution Paper
Super White Paper	Letter: up to 10mm	Left	Plain Paper
Glossy Photo Paper	Letter: up to 10 sheets* ¹ 4"×6": up to 20 sheets Credit Card: up to 20 sheets	Left	Glossy Photo Paper
Matte Photo Paper	Letter: up to 10 sheets 4"×6": up to 20 sheets	Left	Matte Photo Paper
Photo Paper Plus Double Sided* ¹ * ²	Letter: 1 sheet 5"×7": 1 sheet	Left	Photo Paper Plus Double Sided
Photo Paper Plus Glossy* ¹	Letter: up to 10 sheets 4"×6": up to 20 sheets 5"×7": up to 10 sheets	Left	Photo Paper Plus Glossy
Photo Paper Plus Semi-Gloss* ¹	Letter: up to 10 sheets 4"×6": up to 20 sheets 8"×10": up to 10 sheets	Left	Photo Paper Plus Glossy
Photo Paper Pro	Letter: up to 10 sheet 4"×6": up to 20 sheets 4"×8": up to 20 sheets 8"×10": up to 10 sheets	Left	Photo Paper Pro
Photo Stickers* ³ * ⁴	1 sheet	Left	Photo Paper Plus Glossy
T-Shirt Transfers	1 sheet	Right	T-Shirt Transfers

*1 When loading a stack of paper, the printed side may be marked when it is fed in. If this happens, load paper one sheet at a time.

*2 Photo Paper Plus Double Sided is not supported by Macintosh systems.

*3 You can specify the print setting easily by using the Easy-PhotoPrint provided with the *Setup CD-ROM*. For instructions on how to print from the software applications, refer to the *Photo Application Guide*.

*4 You can print photos in a memory card or digital camera on the Canon-branded sticker without a computer. For details, refer to the *Direct Printing Guide*.

-  **Note**
- When using plain paper (64 gsm or 17 lb), up to 100 sheets can be set. Set the paper thickness lever to the left and select **Plain Paper** from **Media Type** in the printer driver.
 - For a detailed description of print media types, refer to the *User's Guide*.



Printing with Windows

-  **Note**
- The menu screens and dialog boxes that appear may vary depending on the application you are using.
 - The steps described in this section are for printing using a computer with Windows® XP Service Pack 2 installed (hereafter called Windows XP SP2).
 - You can use Easy-PhotoPrint to easily do print operations when printing photographs. Easy-PhotoPrint is provided on the *Setup CD-ROM*. For details on how to use Easy-PhotoPrint, refer to the *Photo Application Guide*.

- 1 Turn your printer on, then set papers.
- 2 Create a document or open a file to print.
- 3 Open the printer properties dialog box.
 - (1) Select **Print** from the application's **File** menu.
The **Print** dialog box opens.

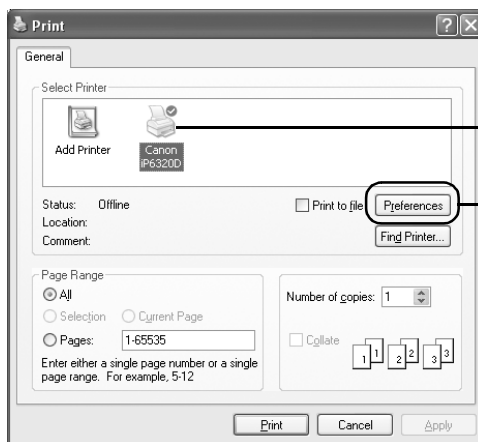

- (2) Ensure that your printer is selected.
- (3) Click **Preferences** or **Properties**.

-  **Note** In Windows 2000, click on the **Main** tab in the **Print** dialog box.

4 Specify the required settings.

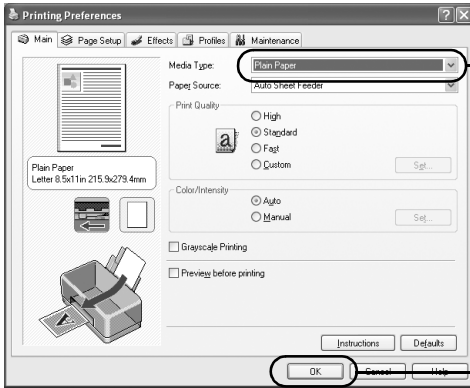

(1) Click **Media Type** to select the media loaded in the printer.

(2) Click **OK**.



Note

- From the **Page Setup** tab, select the correct document size to be printed. If the size is different from that set in the application, then you need to set it to the same size or use **Scaled Printing** or **Fit-to-Page**. Refer to the *Printer Driver Guide*.
- To adjust **Print Quality** settings, select **Custom** and click **Set** on the **Main** tab. You can control the quality in the **Custom** dialog box.
- For details about other printer driver functions, click **Help** or **Instructions** to view the Help or *Printer Driver Guide*. **Instructions** is displayed on the **Main** and **Maintenance** tabs only. If the On-screen Manual is not installed, **Instructions** is not displayed.
- Click the check box to select **Preview before printing**. This will allow you to preview a screen that shows how the selected printing effects on your document will look when printed. Some applications do not contain the preview function.

5 Print the document.

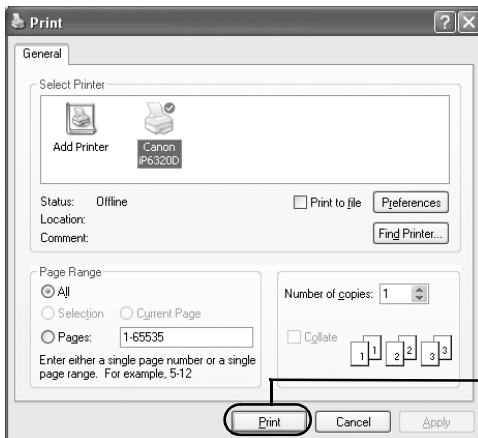

(1) Click **Print** or **OK**.

 **Note** You can cancel a print job in progress by simply pressing the **Stop/Reset** button on the printer.

See “**Cancel Printing**” on page 15.

Macintosh

Printing with Macintosh

-  **Note**
- The menu screens and dialog boxes that appear may vary depending on the software application you are using.
 - The steps described in this section are for printing using a computer with Mac[®] OS X v.10.4.x installed (hereafter called Macintosh[®]).
 - You can use Easy-PhotoPrint to easily do print operations when printing photographs. Easy-PhotoPrint is provided on the *Setup CD-ROM*. For details on how to use Easy-PhotoPrint, refer to the *Photo Application Guide*.

1 Turn your printer on, then set papers.

2 Create a document or open a file to print.

3 Select Paper Size.

(1) Select **Page Setup** from the application's **File** menu.

The **Page Setup** dialog box opens.

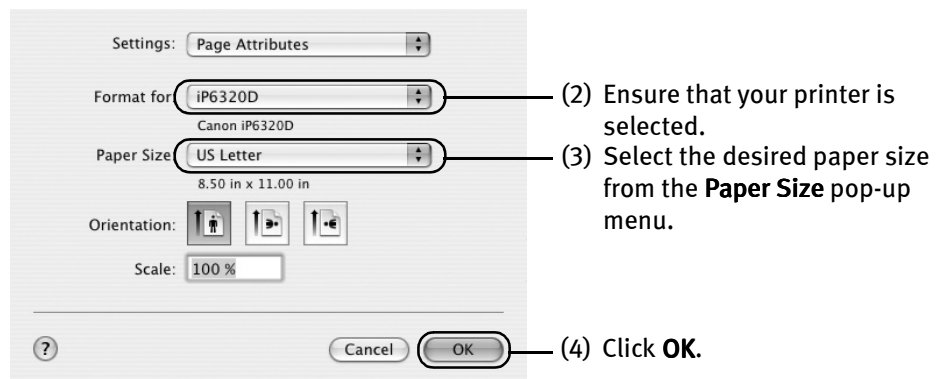

4 Specify the required settings.

(1) Select **Print** from the application's **File** menu.

The **Print** dialog box opens.

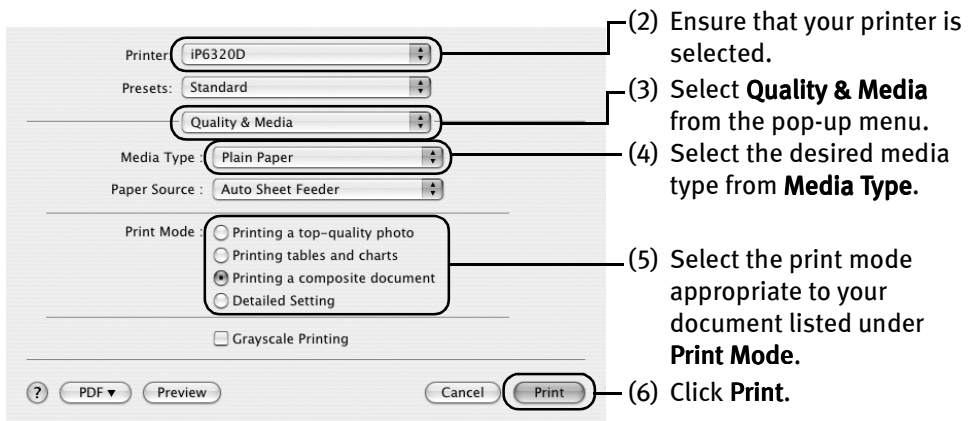

Note • When you select the print mode appropriate to your document under **Print Mode**, the document will be printed in the color and print quality suited to the characteristics of the **Media Type** you have selected.

- **Printing a top-quality photo:** Select when printing documents which mainly consist of photographs and graphics featuring fine color gradation.
- **Printing tables and charts:** Select when printing documents which mainly consist of graphs and graphics (illustrations) with strong color definition.
- **Printing a composite document:** Select when printing documents which are mainly just text.
- **Detailed Setting:** You can fine-tune **Print Quality** and **Halftoning** settings here.

- For details about the printer driver, refer to the *Printer Driver Guide*.
- To view the *Printer Driver Guide*, click **?** on any Print dialog box that has a **Quality & Media**, **Color Options**, **Special Effects**, **Borderless Printing**, or **Margin** selected from the pop-up menu. If the On-screen Manual is not installed, the *Printer Driver Guide* is not displayed even if **?** is clicked.
- Clicking the **Preview** button displays a preview screen that allows you to confirm the selected printing effects and how your document will look when printed. Some applications do not have a preview function.
- You can cancel a print job while printing.

See “**Cancel Printing**” on page 15.

Cancel Printing

Windows

You can cancel a print job while printing by pushing the **Stop/Reset** button on the printer.

- 1 Press the **Stop/Reset** button while the printer is printing.

Printing is canceled and paper is ejected.

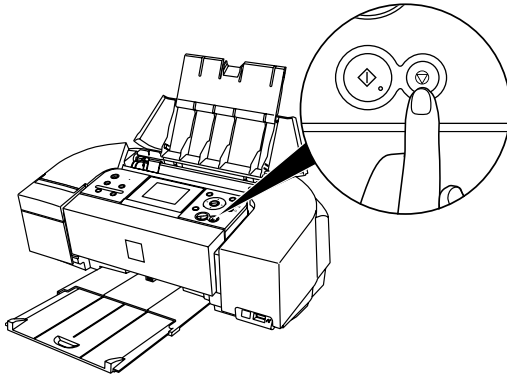

 **Note** You can also cancel a print job by clicking **Cancel Printing** on the **Canon IJ Status Monitor**. To display the **Canon IJ Status Monitor**, click **Canon iP6320D/Canon iP6310D** on the taskbar.

Macintosh

- 1 Click the printer's icon in the Dock and display the list of print jobs in progress.

If you are using Mac OS X v.10.2.8, click on the printer icon in the Dock to start up the **Print Center** and double-click on the name of your printer in the **Printer List** to open a list of print jobs in progress.

- 2 Select an undesired document and click the **Delete** icon.

The print job is deleted.

 **Note** To temporarily stop a job in progress, click **Hold**. To cancel all the jobs in the list, click **Stop Jobs**.

Accessing the Printer Driver (Windows)

The printer properties dialog box can be opened from either within an application or directly from the Windows **Start** menu.

 **Note** This manual refers to operations in Windows XP SP2.

These operations may vary depending on the version of your Windows operating system you use.

■ Opening the Printer Properties Dialog Box from your Application Program

 **Note** Depending on your application program, the command and menu names may differ and there may be more steps involved in opening the printer properties dialog box. For more details, see the user's manual regarding your application.

1 In your application program, select the command to print a document.

The **Print** dialog box can usually be opened by selecting **Print** from the **File** menu.

2 Ensure that your printer is selected. Then click **Preferences** (or **Properties**).

The printer properties dialog box opens.

■ Opening the Printer Properties Dialog Box Directly from the Start Menu

This method is used for printer maintenance and configuring shared print settings for all application programs.

1 Click **Start** and select **Control Panel, Printers and Other Hardware**, and then **Printers and Faxes**.

For non-Windows XP users, click **Start**, select **Settings**, and then **Printers**.

2 Select the icon of your printer.

3 Open the **File** menu and select **Printing Preferences** (or **Properties**).

The printer properties dialog box opens.

When opening the printer properties dialog box from **Properties**, the tabs related to the Windows function (e.g., the **Ports** tab, or the **Details** tab) are displayed. These tabs are not displayed, when the printer properties dialog box is opened from **Printing Preferences** or application programs. For details about these tabs, refer to the Windows documentation.

 **Note** For details on how to set each function, refer to the *Printer Driver Guide* or Help.

Using the Bundled Software

The *Setup CD-ROM* includes photo applications designed to edit the photographs taken by a digital camera and print them as photo-lab quality prints without standard white borders. Use the application(s) suitable for your print purposes.

-  **Note**
- To install applications, refer to *Easy Setup Instructions*.
 - For details about photo applications, refer to the *Photo Application Guide*.

■ Easy-PhotoPrint (Windows/Macintosh)

You can make a Borderless Print easily and quickly, just by selecting a photograph taken with a digital camera and the paper type on which to print it. In addition, it has tools to correct red eye caused by the camera's flash or smooth and beautify the facial skin.

It is compatible with ExifPrint*.

■ PhotoRecord (Windows)

You can create fun and unique photo albums with decorative themes such as frame, background, and clip-art. You can also copy or move the decorated photos.

It is compatible with ExifPrint*.

■ Easy-WebPrint (Windows)

You can easily print out homepages displayed on Internet Explorer® in full size without its right-hand side being cropped. This application is automatically added to the Internet Explorer toolbar. Internet Explorer 6.0 is recommended.

* ExifPrint is the worldwide standard. Under ExifPrint, the digital camera can record data tags for specific camera settings and functions such as whether the flash was on or off, if the camera was in portrait or night scene mode, etc.

Canon PIXMA Printers support ExifPrint and use a suitable photo application to read the camera data precisely, producing optimal prints. This enables you to create prints that reproduce color more accurately.

Printing Maintenance

When Printing Becomes Faint or Colors are Incorrect

When printing becomes faint or colors are incorrect, the print head nozzles are probably clogged. Follow the procedures below to clean these nozzles.

 **Note** Before Performing Maintenance

Remove the FINE Cartridge once, then insert it into place again. Refer to “Replacing a FINE Cartridge” in the *Direct Printing Guide*.

Step 1

Refer to “Printing the Nozzle Check Pattern” in the *Direct Printing Guide*.

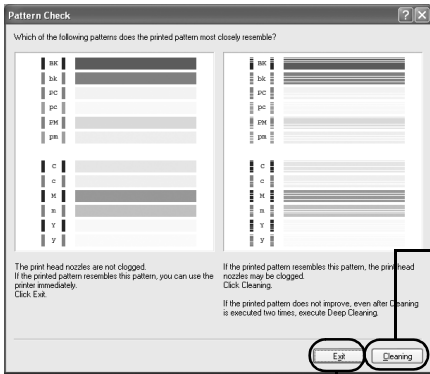

After print head cleaning, print the nozzle check pattern.

If the print quality is poor, perform print head cleaning.

If the pattern is printed normally, click **Exit**.

Step 2

Refer to “Print Head Cleaning” in the *Direct Printing Guide*.

If the problem remains after performing print head cleaning twice

Step 3

Refer to “Print Head Deep Cleaning” in the *Direct Printing Guide*.

If the problem still remains after performing print head deep cleaning twice

Step 4

Refer to “Replacing a FINE Cartridge” in the *Direct Printing Guide*.

 **Note** If ruled lines are misaligned, adjust the print head position.

Refer to “Aligning Print Head - Auto head align” in the *Direct Printing Guide*.

Troubleshooting

This section provides troubleshooting tips for the most common printing problems. Troubleshooting usually falls into one of the following categories.

Refer to the *User's Guide* for additional information on topics not covered in this section. When an error message is displayed on the LCD, refer to “An Error Message is Displayed on the LCD” in the “Troubleshooting” section of the *Direct Printing Guide*. When photos cannot be printed properly from a digital camera, refer to “Cannot Print Properly from the Digital Camera” in the “Troubleshooting” section of the *Direct Printing Guide*.

- “Cannot Install the Printer Driver” on page 20
- “Cannot Connect to PC Properly” on page 21
- “Print Quality is Poor or Contains Errors” on page 22
- “Printer Does Not Start or Stops During Print Jobs” on page 25
- “Paper Does Not Feed Properly” on page 26
- “Paper Jams” on page 26
- “An Error Message Appears on the Screen” on page 27
- “POWER Lamp and Alarm Lamp Flash Alternately” on page 28

Windows

When an Error Occurs

When an error occurs in printing such as the printer is out of paper or paper jams, a troubleshooting message is displayed automatically. Take the appropriate action described in the message.

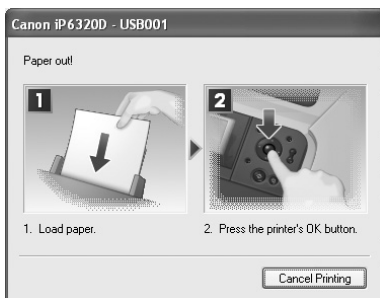

The message may vary depending on the version of your Windows operating system.

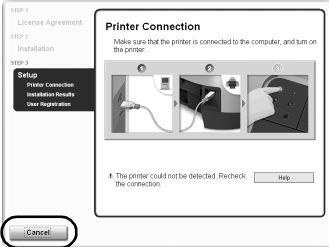

Cannot Install the Printer Driver

Problem	Possible Cause	Try This
Cannot Install the Printer Driver	Installation procedure not followed correctly	<p>Follow the <i>Easy Setup Instructions</i> packaged with your printer for proper printer driver installation.</p> <p>Windows If the installer was forced to be terminated due to an error, Windows may be unstable. Remove the CD-ROM from the CD-ROM drive and restart your computer. Reinstall the printer driver. If this problem persists, refer to your Windows documentation for more information.</p>
	Installation does not start automatically when the <i>Setup CD-ROM</i> is inserted into the drive	<p>Windows If printer driver installation did not start automatically when you inserted the <i>Setup CD-ROM</i> into the CD-ROM drive:</p> <ol style="list-style-type: none"> 1. Click Start and select My Computer. 2. Double-click the CD-ROM icon. <p>For non-Windows XP users, open the My Computer window and then double-click the CD-ROM icon.</p> <p>Macintosh Double-click the CD-ROM icon on your desktop to start installation. If the CD-ROM icon is not displayed on the desktop, there is a problem with the CD-ROM. Contact the Customer Care Center.</p>
	Windows Unable to proceed beyond the Printer Connection screen	 <p>Reinstall the printer driver.</p> <ol style="list-style-type: none"> 1. Click Cancel on the Printer Connection screen. 2. Click Start Over on the Installation Failure screen. 3. Click Back on the screen that appears next. 4. Click Exit on the Welcome screen, then remove the CD-ROM. 5. Turn the printer off. 6. Check the cable connection. 7. Restart the computer. 8. Make sure no other applications (including anti-virus programs) are running. 9. Carefully follow the procedures described in the <i>Easy Setup Instructions</i> and reinstall the driver.

Cannot Connect to PC Properly

Problem	Possible Cause	Try This
<p>Printing Speed Is Slow/USB 2.0 Hi-Speed Connection Does Not Work.</p>	<p>Your environment is not fully compatible with USB 2.0.</p>	<p>If your environment is not fully compatible with USB 2.0, the printer will operate at a lower speed provided under USB 1.1.</p> <p>Check the following to ensure that your PC environment supports USB 2.0 Hi-Speed connection.</p> <ul style="list-style-type: none"> • The USB port on your PC supports USB 2.0 Hi-Speed connection. • Both the USB cable and USB hub support USB 2.0 Hi-Speed connection. <p>Be sure to use a certified USB 2.0 Hi-Speed cable. You are recommended to use the cable no longer than 3 meters.</p> <ul style="list-style-type: none"> • Your PC supports the USB 2.0 Hi-Speed connection. <p>Obtain the latest version of the OS update program and install it on your PC.</p> <ul style="list-style-type: none"> • The USB 2.0 Hi-Speed driver operates properly. <p>Obtain the latest version of the USB 2.0 Hi-Speed driver and install it on your PC.</p> <p> Important For details on checking the above, contact the maker of your computer, USB cable, or USB hub.</p>
<p> Windows When You Connect to a Computer Running Windows XP, the Screen Shows the Warning Message "Hi-speed USB device plugged into non-hi-speed USB hub" or "This device can perform faster".</p>	<p>Your environment is not fully compatible with USB 2.0.</p>	<p>See "Printing Speed Is Slow/USB 2.0 Hi-Speed Connection Does Not Work." above.</p>

Print Quality is Poor or Contains Errors

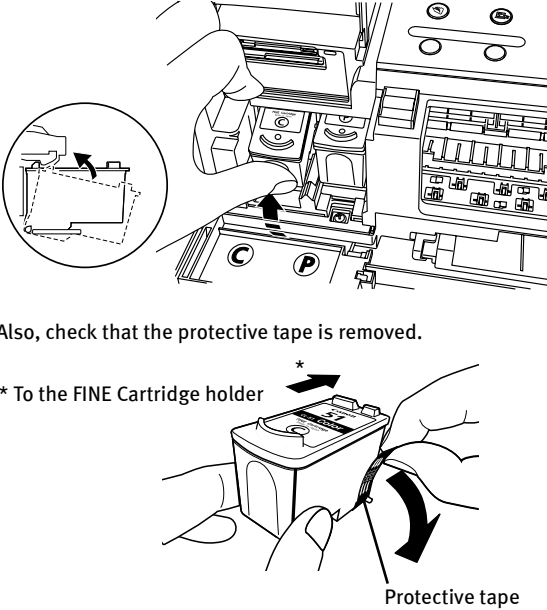
Problem	Possible Cause	Try This
Cannot Print to End of Job	<p>The Page Size setting does not match the size of the paper loaded in the printer</p> <p>Windows The size of the print data is too large</p>	<p>First, check the Page Size setting in the application. Then, check the Page Size setting in the Page Setup tab of the printer driver for Windows or the Page Setup dialog box of the printer driver for Macintosh.</p> <p>Check the size of the print data. For Windows XP and Windows 2000, if the size of the data is too large, part of it may be lost. When the spool format is EMF, follow the procedure below.</p> <ol style="list-style-type: none"> 1. Open the printer properties dialog box. See "Opening the Printer Properties Dialog Box Directly from the Start Menu" on page 16. 2. On the Page Setup tab, click Print Options. 3. Select the Reduce spool data size check box and click OK. When Reduce spool data size is selected, the print quality may be degraded.
Ink Does Not Eject Properly/Not Printed/Printing is Blurred/Colors are Wrong/White Streaks Appear	FINE Cartridge is not installed properly/there is no ink left	<p>Remove the FINE Cartridge, then reinstall it. Small dusts may be stuck between the contact points. In this case, the print out result may be improved by reinstalling the FINE Cartridge.</p>  <p>Also, check that the protective tape is removed.</p> <p>* To the FINE Cartridge holder</p> <p>Protective tape</p>
Print head nozzles are clogged	Print head nozzles are clogged	<p>Print the nozzle check pattern to ensure that ink is ejected properly. Refer to "Printing the Nozzle Check Pattern" in the <i>Direct Printing Guide</i>. If the ink is not ejected properly: Refer to "Print Head Cleaning" in the <i>Direct Printing Guide</i>. Refer to "Print Head Deep Cleaning" in the <i>Direct Printing Guide</i>.</p>

Problem	Possible Cause	Try This
	Incorrect paper type	<p>Windows On the Main tab of the printer driver, ensure that the Media Type selected matches the media being used.</p> <p>Macintosh In the Print dialog box of the printer driver, select Quality & Media from the pop-up menu, and then ensure that the Media Type selected matches the paper loaded.</p>
	Glossy photo paper other than Canon genuine paper is used	Select Other Photo Paper from Media Type , which may resolve the problem. Load one sheet at a time and remove each sheet as soon as it is printed.
	Print Quality is not set properly	<p>Be sure to set the Print Quality setting to High for Windows or Fine for Macintosh.</p> <p>Windows</p> <ol style="list-style-type: none"> 1. Open the printer properties dialog box. See “Opening the Printer Properties Dialog Box from your Application Program” on page 16. 2. On the Main tab, click High for the Print Quality setting. If you cannot select High or the problem is not solved, select Custom, click Set, and select the higher quality. <p>Macintosh</p> <ol style="list-style-type: none"> 1. Open the Print dialog box. You can generally select Print in the File menu from you application program. 2. In the Print dialog box, select Quality & Media from the pop-up menu, and then click Detailed Setting. 3. Drag the Print Quality slide bar towards the Fine side.
	Media is not loaded with print-side up	Check that your paper is loaded with the correct print side facing up. Consult “ Printing Media ” in the <i>User’s Guide</i> for detailed instructions on how to load and use your media.
Printed Ruled Lines are Misaligned	Print head is misaligned	Align the print head. Refer to “ Aligning Print Head-Auto head align ” in the <i>Direct Printing Guide</i> .
	Paper thickness lever position is not proper	Set the paper thickness lever in suitable position for your media. See “ Canon genuine paper ” on page 10.
	Print Quality is not set properly	<p>Be sure to set the Print Quality setting to High for Windows or Fine for Macintosh.</p> <p>Windows</p> <ol style="list-style-type: none"> 1. Open the printer properties dialog box. See “Opening the Printer Properties Dialog Box from your Application Program” on page 16. 2. On the Main tab, click High for the Print Quality setting. If you cannot select High or the problem is not solved, select Custom, click Set, and select the higher quality. <p>Macintosh</p> <ol style="list-style-type: none"> 1. Open the Print dialog box. You can generally select Print in the File menu from you application program. 2. In the Print dialog box, select Quality & Media from the pop-up menu, and then click Detailed Setting. 3. Drag the Print Quality slide bar towards the Fine side.

Troubleshooting

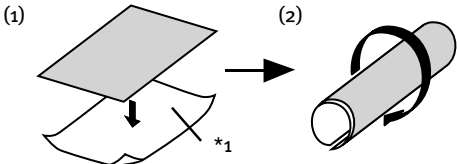
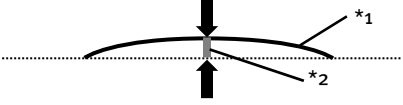
Problem	Possible Cause	Try This
Printed Paper Curls or has Ink Blots	Paper being used is too thin	Use photo paper such as Canon's Photo Paper Pro to print photos or pictures in deep color that have high color saturation.
	Incorrect paper type	<p>Windows On the Main tab of the printer driver, ensure that the Media Type selected matches the media being used.</p> <p>Macintosh In the Print dialog box of the printer driver, select Quality & Media from the pop-up menu, and then ensure that the Media Type selected matches the paper loaded.</p>
Back of Paper is Smudged	Inside of the printer is dirty	If the inside of the printer is dirty, printed paper may become smudged. Periodically clean the inside of the printer. Refer to "Cleaning the Inside of the Printer" in the <i>User's Guide</i> .
	Paper feed roller is dirty	Clean the paper feed roller. Refer to "Back of Paper is Smudged/Paper Does Not Feed Properly/Printed Surface is Scratched" in the <i>Direct Printing Guide</i> .
Printed Surface is Scratched	Inappropriate type of paper is being used	Check to see if the paper you are printing on is too thick or curled. See " Print Media to Avoid " on page 4. Note that smudging may occur at the top and bottom edges of paper when using Borderless Printing . Ensure that the paper you are using is compatible with Borderless Printing .
	Paper is curled	<p>If all four corners or the printing surface of the paper is curled, the paper may become dirty or the paper may not feed properly. Use the paper after correcting paper curl as follows.</p> <ol style="list-style-type: none"> Face up the printing surface ^{*1}, and cover it with a non-printing regular paper to avoid damaging the surface. Roll up the paper in a direction opposite to paper curl as the figure below. <div style="text-align: center;">  </div> <ol style="list-style-type: none"> Check the printing paper if paper curl is corrected within approximately 2 to 5 mm/0.08 to 0.2 inches ^{*2}. It is recommended to print the curl-corrected paper one sheet at a time. <div style="text-align: center;">  </div>
	Paper thickness lever position is not proper	Set the paper thickness lever in suitable position for your media. See " Canon genuine paper " on page 10. If the paper is scratched even when printing on plain paper (left), set the paper thickness lever to the right. Return the paper thickness lever to the left after printing.

Printer Does Not Start or Stops During Print Jobs

Problem	Possible Cause	Try This
<p>Printer Does Not Start or Printer Stops During Print Jobs</p>	<p>There may be problems with your operating system</p>	<p>Restart your computer. It may solve the problem. Delete an undesired print job, if there is any. Use Canon IJ Status Monitor in Windows or Printer Setup Utility (or Print Center) in Macintosh for the deletion.</p> <p>Windows</p> <ol style="list-style-type: none"> 1. Open the printer properties dialog box. See “Opening the Printer Properties Dialog Box Directly from the Start Menu” on page 16. 2. Click the Maintenance tab and then View Printer Status. 3. Click Display Print Queue. 4. Select Cancel All Documents in the Printer menu. <p>Note In Windows XP and Windows 2000 The print jobs may not be selected.</p> <ol style="list-style-type: none"> 5. When the confirmation message is displayed, click Yes. The print job is deleted. <p>Note In Windows Me and Windows 98 Click to select an undesired document and select Purge Print Documents in the Printer menu.</p> <p>Macintosh</p> <ol style="list-style-type: none"> 1. Select Applications from the Go menu. 2. Double-click the Printer Setup Utility icon in the Utilities folder. When using Mac OS X v. 10. 2, double-click the Print Center icon. 3. Double-click the name of your printer displayed under Name in the Printer List. 4. Click to select an undesired document and click . The print job is deleted.
<p>Cannot Print to End of Job</p>	<p>Incorrect page size is selected</p>	<p>Ensure that the page size setting matches the size of the paper loaded in the printer:</p> <ul style="list-style-type: none"> ● Check the Page Size setting from within your application to ensure that it matches the size of the paper loaded. ● Check Page Size on the Page Setup tab in the printer properties dialog box of the printer driver (Windows) or the Page Setup dialog box of the printer driver (Macintosh) to ensure that it matches the size of the paper loaded.
	<p>Windows The size of the print data is too large</p>	<p>Check the size of the print data. For Windows XP and Windows 2000, if the size of the data is too large, part of it may be lost. When the spool format is EMF, follow the procedure below.</p> <ol style="list-style-type: none"> 1. Open the printer properties dialog box. 2. On the Page Setup tab, click Print Options. 3. Select the Reduce spool data size check box, and click OK. <p>Note When Reduce spool data size is set, the print quality may be degraded.</p>



Paper Does Not Feed Properly

Problem	Possible Cause	Try This
Paper Does Not Feed Properly	Inappropriate type of paper is being used	<ul style="list-style-type: none"> Check to see if the paper you are printing on is too thick or curled. See “Print Media to Avoid” on page 4. Check if the paper exceeds the load limit mark. If it exceeds, load less paper. See “Loading Plain Paper” on page 6.
	Paper feed roller is dirty	Clean the paper feed rollers. Refer to “Back of Paper is Smudged/Paper Does Not Feed Properly/Printed Surface is Scratched” in the <i>Direct Printing Guide</i> .
	Paper is loaded incorrectly	Load in the portrait orientation regardless of the print direction of the auto sheet feed. Ensure that paper is loaded correctly. Pinch the paper guide and slide it against the paper stack. See “Loading Paper” on page 4.





Paper Jams

Problem	Possible Cause	Try This
Paper Jams	Landscape credit card-sized paper jams inside the printer	Remove the paper inside of the printer. Refer to “Paper Jams” in “Troubleshooting” section of the <i>Direct Printing Guide</i> .
	Paper jams in the paper output slot/ auto sheet feeder	
	Paper is loaded incorrectly	Check to see if the paper is loaded correctly, and set the paper guide for the loaded paper correctly. See “Loading Paper” on page 4.

An Error Message Appears on the Screen

Problem	Possible Cause	Try This
Windows Writing Error/ Output Error/ Communication Error	Printer not ready	Ensure that the POWER lamp lights. If the POWER lamp is off, turn the printer on. When the POWER lamp is flashing, the printer is initializing. Wait until the POWER lamp stops flashing.
	Paper is not loaded	Load paper and press the OK button. An error message may appear if the “No paper” error has not been reset for a certain period.
	Faulty connection	Ensure that the printer is securely connected to the computer.  Note <ul style="list-style-type: none"> If you are using a switching hub or other device, disconnect the printer and reconnect it directly to the computer and try printing again. If successful, the problem may have been with the device. There could also be a problem with the cable(s). Replace the cable(s) and try printing again.
	Printer port setting does not match the interface connected to the printer	Check the printer port settings. 1. Click Start and select Control Panel, Printers and Other Hardware , and then Printers and Faxes . For non-Windows XP, click Start , select Settings , and then Printers . 2. Select the icon of your printer. 3. Open the File menu and select Properties . 4. Click the Ports tab (or the Details tab) to confirm the port settings. A USB port is selected if either USBnnn (Canon iPXXXXX) or MPUSBPRNnn (Canon iPXXXXX) (where n is a number, and XXXXX represents 6320D or 6310D.) is indicated. If the port setting is not correct, change the port setting according to the interface you are using on the Ports tab (or the Details tab), or reinstall the printer driver.
	Printer driver is not installed properly	Uninstall then reinstall the printer driver. 1. Click Start , and select All Programs (or Programs) , the name of your printer, and Uninstall . 2. Follow the on-screen instructions to uninstall the driver. 3. Follow the procedures described in the <i>Easy Setup Instructions</i> and reinstall the printer driver.
Macintosh “Error No.: 300”	Printer not ready	Ensure that the POWER lamp lights. If the POWER lamp is off, turn the printer on. If the POWER lamp is flashing, the printer is initializing. Wait until the POWER lamp stops flashing.
	Printer not properly connected	Ensure that the printer is securely connected to the computer.  Note <ul style="list-style-type: none"> If you are using a switching hub or other device, disconnect the printer and reconnect it directly to the computer and try printing again. If successful, the problem may have been with the device. There could also be a problem with the cable(s). Replace the cable(s) and try printing again.
	Printer you want to use is not selected on the Printer pop-up menu on the Print dialog box	Select your printer name on the Printer pop-up menu on the Print dialog box. If your printer name does not appear on the Printer pop-up menu, do the following to confirm the printer settings: 1. Select Print and Fax Preferences from the Printer pop-up menu. When using Mac OS X v.10.3.x or Mac OS X v.10.2.8, select Edit Printer List from the Printer pop-up menu. 2. Ensure that your printer name is displayed and the check box is selected in the screen that is displayed. When using Mac OS X v.10.2.8, ensure that your printer name is displayed in the Printer List . 3. If your printer name is not displayed in the screen displayed in step 2, click Add(+) to add the printer. If you cannot add the printer, follow the procedures described in <i>Easy Setup Instructions</i> and reinstall the driver.

Troubleshooting

Problem	Possible Cause	Try This
 “Error No.: 1700/1711”	Ink absorber almost full	The printer has a built-in ink absorber to hold the ink used during print head cleaning, for example. This error message indicates that this ink absorber is nearly full. Press the OK button to clear the error so you can continue printing. Before the ink absorber becomes completely full, contact the Customer Care Center. When you experience this error, you will need to call for servicing to replace the ink absorber and to check the printer for proper operation.
 “Error No.: 2001”	A specified period of time has elapsed without receiving a response from the digital camera/The digital camera or digital video camcorder connected is not compatible with this printer	Disconnect the camera cable, and reconnect it.  Note Depending on the model or brand of your PictBridge compliant device, you may have to select a print mode before connecting the device. You may also have to turn on the device or select Play mode manually after connecting the device to the printer. Perform necessary operations according to the instruction manual supplied with your device. If the error is still unresolved, there is a possibility that you are using a digital camera or digital video camcorder that is not supported by this printer. PictBridge-compatible digital camera or digital video camcorder can be connected to your printer for Direct Printing.
 “Error No.: 2500”	Automatic print head alignment failed	Refer to “An Error Message is Displayed on the LCD” in the <i>Direct Printing Guide</i> .

POWER Lamp and Alarm Lamp Flash Alternately

Problem	Possible Cause	Try This
POWER Lamp and Alarm Lamp Flash Alternately	An error that requires contacting the Customer Care Center may have occurred	Disconnect the printer cable from the printer, and then turn the printer off and unplug the printer from the power supply. Plug the printer back in and turn the printer back on after leaving it for a while. If the problem remains, contact the Customer Care Center.

Appendix

Specifications

Printer

Maximum resolution (dpi):	4800 (horizontal)* x 1200 (vertical) *Ink droplets can be placed in a pitch of 1/4800 inch at minimum.
Print speed * *Print speed will vary depending on system configuration, software, document complexity, print mode and page coverage.	Black printing (text pattern) Max speed (custom setting 5): 12 ppm Standard: 3.4 ppm Color printing Max Speed (custom setting 5): 10 ppm Standard: 2.9 ppm
Print width:	203.2 mm max. (8.0 in) (for Borderless Printing: 215.9 mm/8.5 in)
Interface:	USB 2.0 Hi-Speed^{*1*2}/Direct Print Port/IrDA v.1.2^{*3}/Bluetooth v.1.2 (Option) ^{*1} All operations are not guaranteed for computers standard-equipped with a USB 2.0 Hi-Speed interface. ^{*2} Since the USB 2.0 Hi-Speed interface is fully upwardly compatible with USB Full-Speed (USB 1.1), it can be used at USB Full-Speed (USB 1.1). ^{*3} IrDA v.1.2 is not supported with iP6310D.
Acoustic noise level:	Approx. 43 dB (A) (in the highest print quality mode)
Operating environment:	Temperature: 5 to 35°C (41 to 95°F) Humidity: 10 to 90%RH (no condensation)
Storage environment:	Temperature: 0 to 40°C (32 to 104°F) Humidity: 5 to 95% RH (no condensation)
Power supply:	AC 100-240 V, 50/60 Hz
Power consumption:	Standby: Approx. 1 W Printing: Approx. 11 W Off: Approx. 0.5 W
Dimensions (with a paper support and paper output tray retracted):	438 (W) x 260 (D) x 172 (H) mm 17.24 (W) x 10.24 (D) x 6.77 (H) in
Weight:	iP6320: Approx. 3.5 kg (7.70 lb.) iP6310: Approx. 3.4 kg (7.48 lb.)
Canon FINE Cartridges:	Nozzles: Color: 192 x 2 x 3 nozzles Photo: 192 x 2 x 3 nozzles

Camera Direct Print (PictBridge)

Paper size:	Default (selections based on the printer setting), 10 x 15 cm/4" x 6" (Photo Paper Plus Glossy, Photo Paper Pro, Photo Paper Plus Semi-Gloss, Glossy Photo Paper, or Photo Sticker^{*1}), 13 x 18 cm/5" x 7" (Photo Paper Plus Glossy)^{*2}, A4/8.5" x 11" (Letter) (Photo Paper Plus Glossy A4/Letter, Photo Paper Pro A4/Letter, Photo Paper Plus Semi-Gloss A4/Letter, Glossy Photo Paper A4/Letter, or Plain Paper A4/Letter), 5.4 x 8.6 cm/ Credit Card (Glossy Photo Paper Credit Card) ^{*1} Canon-brand sticker. Printing on this paper is available only when the Layout function on your camera has a 16-up option. For details, refer to "Printing Photographs Directly from a PictBridge Compliant Device" in the <i>Direct Printing Guide</i> . ^{*2} If using a Canon PictBridge-compatible camera, you can select it.
Paper type:	Default (selections based on the printer setting), Photo (Photo Paper Plus Glossy, Photo Paper Plus Semi-Gloss, Glossy Photo Paper), Fast (Photo Paper Pro), Plain Paper (A4/Letter only)
Layout:	Default (selections based on the printer setting), Borderless, Bordered, N-up (2, 4, 9, 16)[*], 35-up^{*2} ^{*1} Layout compatible with Canon-brand sticker above. For details, refer to "Printing Photographs Directly from a PictBridge Compliant Device" in the <i>Direct Printing Guide</i> . ^{*2} Photos are printed in 35mm Film Style layout (contact printing layout). This option can be selected for Canon PictBridge-compliant devices only. (Note that this option cannot be used for some models.) For a Canon PictBridge-compliant device, selecting the item displayed with the [i] icon prints the shooting information (Exif data) in list format, or in the margins of specified photos. (Note that these options cannot be used for some models.)
Trimming:	Default (Off: No trimming), On (follow camera's setting), Off
Image optimize:	Default (selections based on the printer setting), VIVID[*], NR (Noise Reduction)[*], VIVID+NR[*], Face[*] [*] If using a Canon PictBridge-compatible camera, you can select it.
Date/File No. print:	Default (Off: No printing), Date, File No., Both, Off

Minimum System Requirements*¹

Windows *²

Interface	Operating System	Processor	RAM	Hard Disk Space* ⁴
USB 2.0 Hi-Speed	Windows XP SP1, SP2	PentiumIII* ³ (Celeron 566 MHz)	128 MB	400 MB
	Windows 2000 Professional SP4			
USB	Windows XP SP1, SP2	PentiumII 300 MHz* ³		
	Windows 2000 Professional SP2, SP3, SP4			
	Windows Millennium Edition			
	Windows 98, 98 Second Edition			

Macintosh *²

Interface	Operating System	Processor	RAM	Hard Disk Space* ⁴
USB 2.0 Hi-Speed	Mac OS X v.10.4	Intel processor PowerPC G3/G4/G5	256 MB	250 MB
USB	Mac OS X v.10.2.8 - v.10.3		128 MB	

*¹ Conform to the operating system's requirement when it is higher than this.

For updated compatibility, visit our website.

*² Operation can only be guaranteed on a PC with built-in USB or USB 2.0 Hi-Speed port and pre-installed Windows XP, 2000, Me, 98 or Mac OS X v.10.2.8-v.10.4.

*³ Including compatible processors.

*⁴ For bundled software installation.

- CD-ROM drive

Windows

- Display: 800 x 600
Color 16 bit

- Mac File System: Mac OS Extended (Journaled), Mac OS X Extended

Macintosh

- Display: 800 x 600
Thousands Colors

Additional Systems Requirements for On-screen Manuals

Windows

Browser: Windows HTML Help Viewer

Note: Microsoft Internet Explorer 5.0 or later must be installed. The on-screen manual may not be displayed properly depending on your operating system or Internet Explorer version. We recommend that you keep your system up to date with Windows Update.

Macintosh



Browser: Help Viewer

Note: The on-screen manual may not be displayed properly depending on your operating system. We recommend that you keep your system up to date.

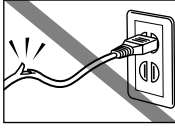
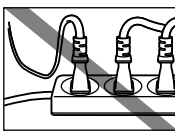
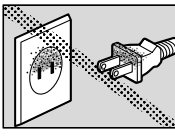

⚠ Safety Precautions

Please read the safety warnings and cautions provided in this manual to ensure that you use your printer safely. Do not attempt to use your printer in any other way than is described in this manual.

Warning You may cause an electric shock/fire or damage the printer if you ignore any of these safety precautions.

Choosing a location	Do not place the printer close to flammable solvents such as alcohol or thinners.
Power supply	Never attempt to plug in or unplug the printer from the power supply when your hands are wet.
	Always push the plug all the way into the power outlet.
	<p>Never damage, modify, stretch or excessively bend or twist the power cord. Do not place heavy objects on the power cord.</p> 
	<p>Never plug the printer into a power socket that is shared with other equipment (extension lead/cord, 2- or 3- way adapter, etc.).</p> 
	Never use the printer if the power cord is bundled or knotted.
	<p>If you detect smoke, unusual smells or strange noises around the printer, immediately unplug the printer at the power supply and call for service.</p> <p>Periodically, unplug the printer and use a dry cloth to wipe off any dust or dirt collected on the plug and the power outlet.</p> <p>If the printer is placed at a location exposed to a lot of dust, smoke, or high humidity, dust collected on the plug will absorb moisture and may cause insulation failure and fire.</p> 
Cleaning the printer	<p>Use a damp cloth to clean the printer. Never use flammable solvents such as alcohol, benzene or thinners.</p> <p>If flammable solvents come in contact with the electrical components inside the printer, it could cause a fire or electric shock.</p> 
	<p>Always unplug the printer from the power outlet before cleaning the printer.</p> <p>If you accidentally switch the printer on while cleaning it, you could injure yourself or damage the printer.</p>
Maintaining the printer	<p>Do not attempt to disassemble or modify the printer. There are no user serviceable parts inside the printer.</p> <p>The printer contains high-voltage components. Never attempt any maintenance procedure which is not described in this guide.</p>
Working around the printer	<p>Do not use flammable sprays near the printer.</p> <p>This could cause a fire or electric shock if spray were to come in contact with the electrical components inside the printer.</p>

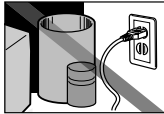
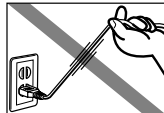
Caution You may cause injury or damage the printer if you ignore any of these safety precautions.

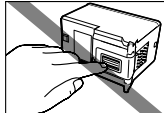
Choosing a location	Do not install the printer in a location that is unstable or subject to excessive vibration.	
	Do not install the printer in locations that are very humid or dusty, in direct sunlight, outdoors, or close to a heating source. To avoid the risk of fire or electric shocks, install the printer in a location that has a constant temperature range of 5°C to 35°C (41°F to 95°F) and humidity of 10% to 90% (condensation free).	
	Do not place the printer on a thick rug or carpet.	
Power supply	Ensure that the area around the power outlet is kept clear at all times so you can easily unplug the power cord when if necessary.	
	Never remove the plug by pulling on the cord.	
	Do not use an extension lead/cord.	
	Never use a power supply source other than the one rated for the printer in the country of where you purchased the printer. AC 100-240 V, 50/60 Hz	
Working around the printer	Never put your hands or fingers in the printer while it is printing.	
	When moving the printer, carry the printer at both ends.	
	Do not place any object on the printer.	
	Do not place any metal objects (paper clips, staples, etc.) or containers of flammable solvents (alcohol, thinners, etc.) on top of the printer.	
	Should any foreign object (metal or liquid) fall into the printer, unplug the power cord and call for service.	
	When installing or transporting this printer, do not incline it, lay it down on its side, or turn it upside down. Ink can leak.	
FINE Cartridges (Ink Cartridges)	For safety reasons, store FINE Cartridges (Ink Cartridges) out of the reach of small children. If a child should ingest any ink, consult a doctor immediately.	
	Do not shake FINE Cartridges (Ink Cartridges). Ink may leak out and stain clothing or the surrounding area.	
	Never touch the electrical contacts or nozzles on a FINE Cartridge (Ink Cartridge) after printing. The metal parts may be very hot and could cause burns.	

Regulatory Information

For 120V, 60Hz model

Model Number: K10256 (iP6320D)/K10257 (iP6310D)

This device complies with Part 15 of the FCC Rules. Operation is subject to the following two conditions: (1) This device may not cause harmful interference, and (2) this device must accept any interference received, including interference that may cause undesired operation.

Note: This equipment has been tested and found to comply with the limits for a Class B digital device, pursuant to Part 15 of the FCC Rules. These limits are designed to provide reasonable protection against harmful interference in a residential installation. This equipment generates, uses and can radiate radio frequency energy and, if not installed and used in accordance with the instructions, may cause harmful interference to radio communications. However, there is no guarantee that interference will not occur in a particular installation. If this equipment does cause harmful interference to radio or television reception, which can be determined by turning the equipment off and on, the user is encouraged to try to correct the interference by one or more of the following measures:

- Reorient or relocate the receiving antenna.
- Increase the separation between the equipment and receiver.
- Connect the equipment into an outlet on a circuit different from that to which the receiver is connected.
- Consult the dealer or an experienced radio/TV technician for help.

Use of a shielded cable is required to comply with Class B limits in Subpart B of Part 15 of the FCC Rules.

Do not make any changes or modifications to the equipment unless otherwise specified in the manual. If such changes or modifications should be made, you could be required to stop operation of the equipment.

Canon U.S.A., Inc.
One Canon Plaza
Lake Success, NY 11042
1-516-328-5600

(For U.S.A. Only)

Canadian Radio Interference Regulations

This digital apparatus does not exceed the Class B limits for radio noise emissions from a digital apparatus as set out in the interference-causing equipment standard entitled "Digital Apparatus", ICES-003 of the Industry Canada.

Cet appareil numérique respecte les limites de bruits radioélectriques applicables aux appareils numériques de Classe B prescrites dans la norme sur le matériel brouilleur NMB-003 d'Industrie Canada intitulée « Appareils numériques ».

CANON U.S.A., INC. LIMITED WARRANTY --- (USA Only)

The limited warranty set forth below is given by Canon U.S.A., Inc. ("Canon USA") with respect to the new or refurbished Canon-brand product ("Product") packaged with this limited warranty, when purchased and used in the United States only.

The Product is warranted against defects in materials and workmanship under normal use and service (a) for a period of one (1) year from the date of original purchase when delivered to you in new condition in its original container or (b) for 90 days from the date of original purchase for refurbished Products. Defective parts or a defective Product returned to a Canon USA repair facility or a Canon USA Authorized Service Facility ("ASF"), and proven to be defective upon inspection, will be repaired, exchanged for new or comparable rebuilt parts, or exchanged for a refurbished Product, as determined by the Canon USA repair facility or the ASF. Warranty repair or replacement shall not extend the original warranty period of the Product. A dated proof of purchase is required at the time of warranty service. A copy of your dated bill of sale will satisfy this requirement. This warranty does not cover any accessories, or any consumables, such as paper or ink cartridges, as to which there shall be no warranty or replacement.

This limited warranty shall only apply if the Product is used in conjunction with compatible computers, peripheral equipment and software. Canon USA shall have no responsibility for such items except for compatible Canon brand peripheral equipment covered by a separate warranty ("Separate Warranty"). Repairs of such Canon brand peripheral equipment shall be governed by the terms of the Separate Warranty. Non-Canon brand equipment and software that may be distributed with the Product are sold "as is" and without warranty of any kind by Canon USA, including any implied warranty regarding merchantability or fitness for a particular purpose, and all such warranties are disclaimed. The sole warranty, if any, with respect to such non-Canon brand items is given by the manufacturer or producer thereof.

This limited warranty covers all defects encountered in normal use of the Product and does not apply in the following cases:

- (a) Loss of or damage to the Product due to abuse, neglect, mishandling, improper packaging by you, alteration, accident, electrical current fluctuations, improper use, failure to follow operating or maintenance instructions in, or environmental conditions prescribed in, Canon USA's user's manual or other documentation, or services performed by someone other than a Canon USA repair facility or ASF. Without limiting the foregoing, dropping the Product, scratches, and abrasions will be presumed to have resulted from misuse, abuse or failure to operate the Product as set forth in the user's manual or other documentation for the Product.
- (b) Use of parts or supplies (other than those sold by Canon USA) that cause damage to the Product or cause abnormally frequent service calls or service problems.
- (c) If the Product has had its serial number or dating defaced, altered or removed.

ANY SYSTEM SOFTWARE (WHETHER FACTORY LOADED ON THE PRODUCT OR CONTAINED ON THE SOFTWARE DISKETTES OR CD-ROMS ENCLOSED WITH, OR ACCOMPANYING, THE PRODUCT), AND ANY UTILITY SOFTWARE, DISTRIBUTED WITH OR FOR THE PRODUCT, IS SOLD "AS IS" AND WITHOUT WARRANTY BY CANON USA. THE SOLE WARRANTY WITH RESPECT TO SUCH SOFTWARE IS CONTAINED IN THE SOFTWARE MANUFACTURER'S LICENSE AGREEMENT DISTRIBUTED THEREWITH, INCLUDING ANY LIMITATIONS AND DISCLAIMERS THEREON. PLEASE CONTACT CANON USA IMMEDIATELY IF YOU HAVE NOT RECEIVED A COPY OF THE SOFTWARE MANUFACTURER'S LICENSE AGREEMENT.

NO IMPLIED WARRANTY, INCLUDING ANY IMPLIED WARRANTY OF MERCHANTABILITY OR FITNESS FOR A PARTICULAR PURPOSE, APPLIES TO THE PRODUCT AFTER THE APPLICABLE PERIOD OF THE EXPRESS LIMITED WARRANTY STATED ABOVE, AND NO OTHER EXPRESS WARRANTY OR GUARANTY, EXCEPT AS MENTIONED ABOVE, GIVEN BY ANY PERSON OR ENTITY WITH RESPECT TO THE PRODUCT SHALL BIND CANON USA, OR ITS ASF. (SOME STATES DO NOT ALLOW LIMITATIONS ON HOW LONG AN IMPLIED WARRANTY LASTS, SO THE ABOVE LIMITATION MAY NOT APPLY TO YOU.) CANON USA SHALL NOT BE LIABLE FOR LOSS OF REVENUES OR PROFITS, INCONVENIENCE, EXPENSE FOR SUBSTITUTE EQUIPMENT OR SERVICE, STORAGE CHARGES, LOSS OR CORRUPTION OF DATA, OR ANY OTHER SPECIAL, INCIDENTAL OR CONSEQUENTIAL DAMAGES CAUSED BY THE USE, MISUSE, OR INABILITY TO USE THE PRODUCT REGARDLESS OF THE LEGAL THEORY ON WHICH THE CLAIM IS BASED, AND EVEN IF CANON USA OR ITS ASF HAS BEEN ADVISED OF THE POSSIBILITY OF SUCH DAMAGES. NOR SHALL RECOVERY OF ANY KIND AGAINST CANON USA OR ITS ASF BE GREATER IN AMOUNT THAN THE PURCHASE PRICE OF THE PRODUCT CAUSING THE ALLEGED DAMAGE. WITHOUT LIMITING THE FOREGOING, YOU ASSUME ALL RISK AND LIABILITY FOR LOSS, DAMAGE OR INJURY TO YOU AND YOUR PROPERTY AND TO OTHERS AND THEIR PROPERTY ARISING OUT OF THE POSSESSION, USE, MISUSE, OR INABILITY TO USE THE PRODUCT SOLD BY CANON USA NOT CAUSED SOLELY AND DIRECTLY BY THE NEGLIGENCE OF CANON USA, OR ITS ASF. (SOME STATES DO NOT ALLOW THE EXCLUSION OR LIMITATION OF INCIDENTAL OR CONSEQUENTIAL DAMAGES, SO THE ABOVE EXCLUSION OR LIMITATION MAY NOT APPLY TO YOU.) THIS LIMITED WARRANTY SHALL NOT EXTEND TO ANYONE OTHER THAN THE ORIGINAL PURCHASER OF THE PRODUCT OR THE PERSON FOR WHOM IT WAS PURCHASED AS A GIFT, AND STATES YOUR EXCLUSIVE REMEDY.

Canon USA offers a range of customer technical support* options:

- Interactive troubleshooting, e-mail technical support, the latest driver downloads and answers to frequently asked questions (www.canontechsupport.com)
- Toll-free live technical support Monday-Saturday (excluding holidays) at **1-800-828-4040**

Appendix

- Telephone Device for the Deaf (TDD-1-866-251-3752)
- Repair or Exchange Service Options:
In the event service is required for the Product during the limited warranty period, Canon USA offers two hardware support options:

Authorized Service Facility Carry-In / Mail-In Service

Canon USA's Carry-In/Mail-In Service provides repair or exchange, at Canon USA's option, through Canon USA's Authorized Service Facility (ASF) network. The name and telephone number of the ASF(s) near you may be obtained from Canon USA's Web site at: www.canontechsupport.com or by calling the Canon USA Customer Care Center at 1-800-828-4040, or any time while speaking to a technical support person. A Product covered by this limited warranty will be repaired or exchanged, as determined by Canon USA, and returned without charge by the ASF.

InstantExchange Service **

A Canon Customer Care Center or ASF technician will attempt to diagnose the nature of the problem and, if possible, correct it over the telephone. If the problem cannot be corrected over the telephone, and you elect the InstantExchange option, a reference number will be issued to you. You will be asked for the Product serial number and other information pertaining to your defective Product and for a ship-to location for the replacement Product (must include street address).

The Canon USA repair facility will ship out the replacement Product, via 2nd day Air freight service, prepaid by Canon USA. After receipt of the replacement Product (with instructions and a prepaid waybill), follow the enclosed instructions on how to ship the defective Product to the Canon USA repair facility. The defective Product must be returned in the shipping carton in which the replacement Product was packed and include the reference number, A COPY OF YOUR DATED PROOF OF PURCHASE (BILL OF SALE), and a complete explanation of the problem. DO NOT INCLUDE ANY OTHER ITEMS WITH THE DEFECTIVE PRODUCT IN THE RETURN SHIPPING CARTON, AND BE SURE TO RETAIN YOUR PRINthead AND INK CARTRIDGE(S) AND TANK(S).

InstantExchange Service expedites, usually by the second business day, the exchange of a defective Product with a replacement Product, which will normally be shipped the same day if your request for this service is by 3 p.m. E.T. Monday through Friday, except holidays (three (3) business day InstantExchange Service for Alaska and Hawaii). Canon USA does not guarantee expedited shipping service in the event of the occurrence of factors beyond its reasonable control. The replacement Product you receive may be a refurbished or reconditioned unit and will be covered for the balance of the period remaining on your original limited warranty. NOTE THAT BY USING THIS SERVICE YOU WILL KEEP THE REPLACEMENT PRODUCT THAT IS SENT TO YOU. CANON USA WILL RETAIN THE DEFECTIVE PRODUCT THAT YOU ORIGINALLY PURCHASED, WHICH SHALL BECOME THE PROPERTY OF CANON USA. InstantExchange warranty program service is available only during the express limited-warranty period for your Product and only in the continental United States, Alaska and Hawaii during such period.

This limited warranty gives you specific legal rights, and you may also have other rights, which vary from state to state.

* Support program specifics are subject to change without notice.

** InstantExchange warranty service is subject to the availability of refurbished or new replacement units.

Canon U.S.A., Inc.
One Canon Plaza
Lake Success, NY 11042
USA

Canon is a registered trademark of Canon Inc.

©2006 Canon U.S.A., Inc. Canon is a registered trademark of Canon Inc. in the United States and may also be a registered trademark in other countries.

Index

A

- Alarm lamp 2
- An Error Message Appears on the Screen27

B

- Borderless Print17
- Borderless Printing24

C

- Cancel Printing15
- Cannot Connect to PC Properly21
- Cannot Install the Printer Driver20
- Canon IJ Status Monitor25
- CANON U.S.A., INC. LIMITED WARRANTY --- (USA Only) ..35

D

- Driver
 - settings12, 14
 - uninstalling27

E

- Easy-PhotoPrint17
- Easy-WebPrint17
- ExifPrint17

G

- genuine paper10
- Glossy Photo Paper10

H

- Help button 2
- High Resolution Paper10

L

- Load limit mark 6
- Loading Envelopes 7
- Loading Other Small-Sized Paper 8
- Loading Plain Paper 6

M

- Matte Photo Paper10
- Media Name10
- Media Type 10, 12, 14

O

- Opening the Printer Properties Dialog Box Directly from the Start Menu (Windows)16

- Opening the Printer Properties Dialog Box from your Application Program (Windows) 16

P

- Page Setup (Macintosh) 13
- Page Setup dialog box (Macintosh) 13
- Paper feed roller 26
- Paper Size 13
- Paper Support Load Limit 10
- Paper thickness lever 5
- Paper Thickness Lever Position 10
- Photo Paper Plus Double Sided 10
- Photo Paper Plus Glossy 10
- Photo Paper Plus Semi-Gloss 10
- Photo Paper Pro 10
- Photo Stickers 10
- PhotoRecord 17
- POWER button 2
- POWER lamp 2
- POWER Lamp and Alarm Lamp Flash Alternately 28
- Preparing the Printer 5
- Preview before printing 12
- Print dialog box 11, 14
- Print Head Cleaning 18
- Print Head Deep Cleaning 18
- Print Media to Avoid 4
- Print Mode 14
- Print Quality 12, 22
- Printer Driver Settings for Media Type 10
- Printer Properties dialog box 11, 16, 23
- Printing the Nozzle Check Pattern 18

R

- Replacing a FINE Cartridge 18

S

- Safety Precautions 32
- Specifications 29
- Stop/Reset button 13
- Super White Paper 10

T

- Troubleshooting 19
- T-Shirt Transfers 10
- Turning off the Printer 3
- Turning on the Printer 2

U

- Uninstalling the printer driver 27

Index

USB 2.0 Hi-Speed	21
Using Specialty Media	9

W

When Printing Becomes Faint or Colors are Incorrect ...	18
---	----

Ordering Information

For additional supplies, use the following descriptions and order numbers.

Description	Order #
FINE Cartridges	
CL-41 Color	0617B002
CL-51 Color	0618B002
CL-52 Photo	0619B002
Canon Specialty Papers	
Photo Paper Plus Glossy (4" x 6"/20 sheets)	7980A007
Photo Paper Plus Glossy (4" x 6"/50 sheets)	7980A012
Photo Paper Plus Glossy (4" x 6"/120 sheets)	7980A022
Photo Paper Plus Glossy (5" x 7"/20 sheets)	7980A019
Photo Paper Plus Glossy (8.5" x 11"/20 sheets)	7980A006
Photo Paper Plus Double Sided (5" x 7"/10 sheets)	9981A006
Photo Paper Plus Double Sided (8.5" x 11"/10 sheets)	9981A005
Photo Paper Plus Double Sided Album Kit (5" x 7")	0041B005
Photo Paper Plus Double Sided Album Kit (8.5" x 11")	0041B006
Photo Paper Plus Semi-Gloss (4" x 6"/50 sheets)	8386A010
Photo Paper Plus Semi-Gloss (8.5" x 11"/20 sheets)	8386A007
Photo Paper Pro for Borderless Printing (4" x 6"/20 sheets)	1029A014
Photo Paper Pro for Borderless Printing (4" x 6"/75 sheets)	1029A027
Photo Paper Pro (8.5" x 11"/15 sheets)	1029A004
Photo Paper Pro (8" x 10"/20 sheets)	1029A059
Photo Paper Pro (8.5" x 11"/30 sheets)	1029A028
Matte Photo Paper (4" x 6"/120 sheets)	7981A014
Matte Photo Paper (8.5" x 11"/50 sheets)	7981A004
Photo Paper Glossy (4" x 6"/50 sheets)	0755B021
Photo Paper Glossy (4" x 6"/100 sheets)	0775B022
Photo Paper Glossy (8.5" x 11"/50 sheets)	0775B023
Photo Paper Glossy (8.5" x 11"/100 sheets)	0775B024
Glossy Photo Paper Credit Card Size	9157A023
Photo Stickers	0001C001
High Resolution Paper (8.5" x 11"/100 sheets)	1043A011

Call **1-800-OK-CANON** to locate a dealer near you, or visit the Canon eStore at www.estimate.usa.canon.com.



©2006 Canon U.S.A., Inc. Canon is a registered trademark of Canon Inc. in the United States and may be a registered trademark or trademarks in other countries. All other product and brand names are trademarks of their respective owners. As an ENERGY STAR® partner, Canon U.S.A., Inc. has determined that this product meets the ENERGY STAR® guidelines for energy efficiency.

Quick Start Guide

Canon U.S.A., Inc.

One Canon Plaza, Lake Success, NY 11042, U.S.A.

Canon Inc.

30-2, Shimomaruko 3-Chome, Ohta-ku, Tokyo 146-8501, Japan

Canon Canada, Inc.

6390 Dixie Road, Mississauga, Ontario, L5T 1P7, Canada

Canon Latin America, Inc.

703 Waterford Way, Suite 400, Miami, FL 33126, U.S.A.

Canon Mexicana

Boulevard Manuel Avila Camacho No. 138 PB
y Pisos 15, 16 y 17, Colonia Lomas de Chapultepec
Delegación Miguel Hidalgo, CP 11000, Mexico D.F.

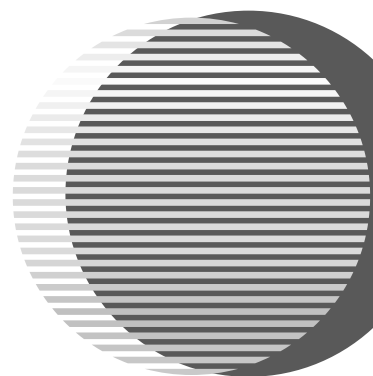

The following FINE Cartridges are compatible with this printer.



CL-41



CL-51



CL-52

For details on FINE Cartridge replacement, refer to "Replacing a FINE Cartridge" in the *Direct Printing Guide*.