

Magnum Forsaire Counterflow Top-Vent Gas Wall Furnace

Model Numbers:**6008532;6038532;6058532**

FOR USE WITH NATURAL GAS ONLY

Model Numbers:**6008531;6038531;6058531**

FOR USE WITH PROPANE GAS ONLY

READ THIS OWNER'S MANUAL CAREFULLY BEFORE YOU INSTALL YOUR NEW WILLIAMS WALL FURNACE.

WARNING: If the information in these instructions is not followed exactly, a fire or explosion may result causing property damage, personal injury or loss of life.

- Do not store or use gasoline or other flammable vapors and liquids in the vicinity of this or any other appliance.
- **WHAT TO DO IF YOU SMELL GAS:**
 - Open all windows.
 - Do not try to light any appliance.
 - Do not touch any electrical switch; do not use any phone or cell phone in your building.
 - Extinguish any open flame.
 - Immediately call your gas supplier from a neighbor's phone. Follow the gas supplier's instructions.
 - If you cannot reach the gas supplier, call the fire department.
- Installation and service must be performed by a qualified installer, service agency or the gas supplier.

WARNING: Improper installation, adjustment, alteration, service or maintenance can cause injury or property damage. Refer to this manual. For assistance or for additional information consult a qualified installer, service agency or the gas supplier.



Warranty

The manufacturer, Williams Furnace Co., warrants this wall furnace or heater to the original purchaser under the following conditions:

LIMITED ONE-YEAR WARRANTY

1. Any part thereof which proves to be defective in material or workmanship within one year from date of original purchase for use will be replaced at the Manufacturer's option, FOB to its factory.
2. No liability is assumed by the Manufacturer for removal or installation labor costs, nor for freight or delivery charges.

LIMITED EXTENDED WARRANTY

1. In addition to the above limited one-year warranty on the complete unit, any combustion chamber which burns out or rusts under normal installation, use and service conditions during a period of nine years following expiration of the one-year warranty period will be exchanged for a like or functionally similar part.
2. No liability is assumed by the Manufacturer for removal or installation labor costs, nor for freight or delivery charges.

LIMITATIONS

1. THIS LIMITED WARRANTY IS THE ONLY WARRANTY MADE BY THE MANUFACTURER, IMPLIED WARRANTIES OF MERCHANTABILITY OR FITNESS FOR ANY PARTICULAR PURPOSE ARE LIMITED TO THE SAME ONE YEAR TERM AS THE EXPRESS WARRANTY. UNDER NO CIRCUMSTANCES SHALL THE MANUFACTURER BE LIABLE FOR INCIDENTAL, CONSEQUENTIAL, SPECIAL OR CONTINGENT DAMAGES OR EXPENSES ARISING DIRECTLY OR INDIRECTLY FROM ANY DEFECT IN THE PRODUCT OR ANY COMPONENT OR FROM THE USE THEREOF. THE REMEDIES SET FORTH HEREIN ARE THE EXCLUSIVE REMEDIES AVAILABLE TO THE USER AND ARE IN LIEU OF ALL OTHER REMEDIES.

Some states do not allow limitation on how long an implied warranty lasts, and some states do not allow the exclusion or limitation of incidental or consequential damages, so the above limitations or exclusions may not apply to you.

2. This warranty does not include any charge for labor or installation.
3. This warranty does not extend to painted surfaces or to damage or defects resulting from accident, alteration, misuses or abuse or improper installation.
4. This warranty does not cover claims which do not involve defective workmanship or materials.

DUTIES OF THE CONSUMER

1. The heating equipment must be installed by a qualified installer and operated in accordance with the installation and homeowner's instructions furnished with the equipment.
2. Any travel, diagnostic costs, service labor, and labor to repair the defective unit will be the responsibility of the owner.
3. A bill of sale, cancelled check, payment record or permit should be kept to verify purchase date to establish the warranty period.
4. Have the installer enter the requested information in the space below.

GENERAL

1. The manufacturer neither assumes nor authorizes any person to assume for it any other obligation or liability in connection with said equipment.
2. Service under this warranty should be obtained by contacting your dealer. Provide the dealer with the model number, serial number, and purchase date verification.
3. If, within a reasonable time after contacting your dealer, satisfactory service has not been received, contact: Customer Service Department, 250 West Laurel Street, Colton, CA 92324 for assistance.
4. THIS WARRANTY GIVES YOU SPECIFIC LEGAL RIGHTS AND YOU MAY ALSO HAVE OTHER RIGHTS WHICH VARY FROM STATE TO STATE.

Installation Record

Model No. _____ Serial No. _____

Original Purchaser _____

Address _____

City and State _____ Zip _____

Dealer _____

Address _____

City and State _____ Zip _____

Installation Date _____ Name _____ Signature _____

(Dealer or authorized representative who certifies that this appliance is installed in accordance with Manufacturer's instructions and local codes.)

Contents

Your Williams Warranty.....	2	Quick Reference: Here's how to...	
Installation Record.....	2	Unpack the furnace	6
Table of Contents	3	Learn how to unpack the new Williams Furnace and verify that all its parts are in working order.	
Safety Rules	4	Install the furnace	7-20
Introduction.....	5	Recessed Mount, Surface Mount, and Vent Installation is all explained starting on page 11.	
Basic Description.....	5	Operate the furnace	25-26
Basic Tools Needed.....	5	Igniting the furnace for the first time.	
Basic Materials Needed	5	Caring for Your Furnace	27-28
Optional Accessories	6	Learn how to keep your new Williams Furnace operating.	
Installing Your Wall Furnace.....	7		
Locating Wall Furnace and Thermostat.....	7-8		
Combustion and Ventilation Air.....	8-11		
Installation			
Recessed Mount Installation.....	11-13		
Surface Mount Installation.....	13-14		
Vent Installation.....	14-16		
Mounting Your Furnace.....	16-17		
Gas Supply and Piping.....	18-19		
Electrical Wiring.....	19		
Thermostat Installation	20		
Optional Accessory Installation.....	21-23		
Start Up Procedure	24		
Operating Your Furnace.....	25-26		
How To Care For Your Furnace.....	27-28		
Furnace Technical Information.....	28		
TROUBLESHOOTING CHART	29-30		
Wiring Diagrams	30		
Repair Parts	31-32		
Repair Parts List.....	33-34		
Forsaire Hardwire Accessary - 9940.....	35		
SERVICE HINTS	Back Cover		
How To Order Repair Parts	Back Cover		

Safety Rules

WARNING: Read these rules and the instructions carefully. Failure to follow these rules and instructions could cause a malfunction of the furnace. This could result in death, serious bodily injury and/or property damage.

INSTALLATION MUST CONFORM TO LOCAL CODES. IN THE ABSENCE OF LOCAL CODES, INSTALLATION MUST CONFORM TO THE NATIONAL FUEL GAS CODE, ANSI Z223.1. THE APPLIANCE, WHEN INSTALLED MUST BE ELECTRICALLY CONNECTED AND GROUNDED IN ACCORDANCE WITH LOCAL CODES OR, IN THE ABSENCE OF LOCAL CODES, WITH THE CURRENT NATIONAL ELECTRICAL CODE ANSI/NFPA NO. 70.

In Canada:

1. Installation must conform to local codes or, in the absence of local codes, the current CAN/CGA B149 installation code.
2. The appliance, when installed, must be electrically connected and grounded in accordance with local codes or, in the absence of local codes, with the current CSA C22.1 Canadian Electrical code.
3. Field conversions for high altitude are not permitted in Canada.
4. Reference is made in this manual regarding gas type as L.P.G. Be advised that L.P.G. is not available in Canada, refer to propane/L.P. Gas.

1. Use only manufacturer's replacement parts. Use of any other parts could cause injury or death.
2. DO NOT install this furnace where it could be isolated by closing doors to the heated space.
3. DO NOT install this furnace in a travel trailer or recreational vehicle.
4. MAINTAIN all clearances specified in section "Locating Wall Furnace and Thermostat".
5. BE SURE this furnace is for type of gas to be used. Check the rating plate by the gas valve in the lower cabinet. Do not change it to use other gases without the proper manufacturer's Gas Conversion Kit.
6. For natural gas, the minimum inlet gas supply pressure for the purpose of input adjustment is 5" water column. The maximum inlet gas supply pressure is 7" water column.
For L.P. Gas, the minimum inlet gas supply pressure for the purpose of input adjustment is 11" water column. The maximum inlet gas supply pressure is 13" water column.
7. Any safety screen, guard or parts removed for servicing this appliance must be replaced prior to operating the appliance to avoid property damage, bodily injury or death.

8. Install the furnace vent directly to the outdoors so that harmful combustible flue gases will not collect inside the building. Follow the venting instructions for your type of installation exactly. Use only the type and size of vent pipe and fittings specified.
9. BE SURE to provide for adequate combustion and ventilation air. The flow of this air to the furnace must not be blocked.
10. NEVER vent flue gases into another room, a fireplace or any space inside a building. This could cause property damage, bodily injury or death.
11. Never test for gas leaks with an open flame. Use a soap solution to check all gas connections. This will avoid the possibility of fire or explosion.
12. ALLOW the furnace to cool before servicing. Always shut off electricity and gas to furnace when working on it. This will prevent any electrical shocks or burns.
13. DUE TO HIGH TEMPERATURES, locate the furnace out of traffic and away from furniture and draperies.
14. ALERT children and adults to the hazards of high surface temperatures and warn them to keep away to avoid burns or clothing ignition.
15. CAREFULLY supervise young children when they are in the same room with the furnace.
16. DO NOT place clothing or other flammable material on or near furnace.
17. INSTALLATION and REPAIR must be done by a qualified service person. The appliance should be inspected before use and at least annually by a professional service person. More frequent cleaning may be required due to excessive lint from carpeting, bedding material, etc. It is imperative that control compartments, burners and circulating air passages be kept clean.
18. BEFORE INSTALLING: To avoid electrical shock, turn off electrical circuits that pass through the wall where you are going to install the furnace.
19. BE AWARE of good safety practices by wearing personal protective equipment such as gloves and safety glasses to avoid being injured by sharp metal edges in or around furnace and while cutting or drilling holes in wood and/or sheet metal.

WARNING: Do not use this furnace if any part has been under water. Immediately call a certified service technician to inspect the furnace and to replace any part of the control system and any gas control which has been under water.

WARNING: Do not install any of these furnaces (Natural or L.P. Gas) in mobile homes, trucks or recreational vehicles.

Introduction

Please read our instructions before you install and use your furnace. This will help you obtain the full value from this furnace. It will also help you avoid any needless service costs if the answer to the problem is found within this instruction manual.

Basic Description

Your Counterflow Top Vented Wall Furnace is shipped ready to install on the surface of a wall or recessed up to 9-1/4 inches in a wall, with wall studs spaced 16 inches center to center.

Vent piping and exhaust are not part of the Williams furnace package and must be purchased separately.

Always consult your local heating or plumbing inspector, building department or gas utility company regarding regulations, codes or ordinances which apply to the installation of a counterflow top vented wall furnace.

Air is drawn in at the top by the fan and discharges through a grille near the floor. A two-speed fan is used with all models. The furnace contains multi-slot burners and burns either Natural or L.P. (Liquefied Petroleum) Gas, depending on the model you have purchased.

This appliance is equipped with a vent safety shutoff system designed to protect against improper venting of combustion products. Operation of this wall furnace when not connected to

a properly installed and maintained venting system or tampering with the vent safety shutoff system can result in carbon monoxide (CO) poisoning and possible death.

The combustion system draws combustion air directly from the room in which the furnace is installed, and through ventilation grilles or ducts connected to the outdoors, such as an attic or crawl space. The combustion gases are discharged through the roof within a listed vent pipe.

The furnace heat exchanger is built of heavy gauge steel treated for corrosion resistance. The fan at the top forces air down along the front, back and sides of the heat exchanger where it is discharged into the room. The furnace cabinet is also constructed of heavy gauge steel and has a neutral beige color enamel paint finish.

The furnace controls are located behind an access door on the lower front of the furnace. All models are equipped with American Gas Association listed gas valves and pilots.

Tools Needed

Hand drill or properly grounded electric drill
Expansion bit 1/2" to 1-5/8" or 1/2" and 1-1/2" blade bits
1/8" and 3/16" drill bit (metal)
6 ft. folding rule or tape measure
Screwdriver (med. blade)
Screwdrivers (Phillips Head)
Pliers (wire cutting)
Hammer

Hole Saw - 2"
1/8" Allen wrench
Stud locator or small finishing nails.
Tin snips
8 and 12" adjustable wrenches
Keyhole or sabre saw
2 - 10" or 12" pipe wrenches
Gloves and safety glasses

Materials

Pipe and fittings to make connections to furnace (See page 18).
Caulking compound-silicone rubber with a temperature rating of 500°F.
DO NOT use caulking advertised as paintable or for bath tub use as most contain fillers and will not withstand high temperatures.
Pipe Joint Compound resistant to L.P. gases.
Electrical wiring supplied as needed (see page 19).
Minimum wire size is #14 gauge copper.
3/4" Quarter Round or other wood trim molding approximately 16' long or Trim Accessory 4791 is recommended.

2" x 4" x (length as required) Spacer Blocks (see Close Off Stud Space, page 12).
Oval Vent Kit 9901 is recommended.
Vent Enclosure Kit 9812 or 9824 if furnace is to be surface mounted is recommended.
1 x 1 wood strips if Optional Side Outlet Grille Register 6701 is used.

Helpful Installation Information

The following booklets will help you in making the installation:

ANSI/NFPA 70-1990 or current edition "National Electrical Code". In Canada: CSA C22.1 Canadian Electrical Code.

American National Standard NFPAS4/ANSI Z223.1 1988 or current edition "National Fuel Gas Code".

Obtained from: American National Standards Institute, Inc., 1430 Broadway, New York, N Y 10018.

In Canada: CAN/CGA B149.

Introduction

Optional Accessories

SIDE OUTLET REGISTER 6701 Pg. 21

Let's you route some heated air to a second room. Mounts on side wall of second room and must be within 10 inches of wall furnace.

DIFFUSER GRILLE KIT 6703 as shown on Page 23, Fig. 32

Let's you route some heated air in a two-way direction. Kit 6704 for one-way direction.

REAR OUTLET KIT 6801

Let's you route some heated air to a second room behind the furnace. Finished wall of second room must be within 10 inches of furnace as shown on Page 8, Fig. D. Built-in damper lets you shut off air flow to second room if desired.

SHORT REAR OUTLET KIT 6802

Let's you route some heated air to a second room behind the furnace when furnace is recessed mounted. Built-in damper lets you control the air flow to the second room.

TRIM STRIP KIT 4701

Provides finished edge at sides of wall furnace. Neutral beige enamel painted steel.

Unpack Your Furnace

The furnace is shipped in one carton containing the furnace, installation instruction booklet and hardware bag.

1. Lay carton horizontally. Open carton and remove top trim cover from its packing. Remove thumb screw at top of furnace, raise top front panel ½ inch and remove panel from cabinet. This is so you can get to the electrical connections later.
2. Place these and other parts, as they are removed from furnace, where they cannot be lost or damaged before you need them.
3. Bottom front panel can be removed by grasping just below handle and pulling it outward and then upward. See Fig. 1.

NOTE

Check the burner rating plate, located in burner compartment, to make sure your furnace is equipped to operate on the type of gas available (either Natural or L.P. Gas). Do NOT convert unit from Natural Gas to L.P. Gas or from L.P. Gas to Natural

4. Remove all literature and package containing thermostat, wire and metal anchors used for free standing installation.
5. Check the fan blade to be sure it spins freely.

OVAL VENT KIT 9901

This U.L. listed B/W vent kit contains 4 feet of oval double walled vent pipe, plate spacers and starter or hold-down plate that starts the venting from the top of the furnace. See page 16 for additional items you will need.

VENT ENCLOSURE KITS 9812 or 9824

These kits are used only when the furnace is surface mounted. They enclose the vent pipe from the top of the surface to the ceiling.

SIDE OUTLET GRILLE KIT 6702 as shown on Page 22, Fig. 31

Allows you to direct heated air from the side of furnace into the same room.

NOTE

All kits are identified on the carton by their Manufacturing Number respectively, 6701, 6703, 6704, 6801, 6802, 4701, 9901, 9812, 9824 and 6702. These numbers are also listed on the furnace rating plate.

FIGURE 1

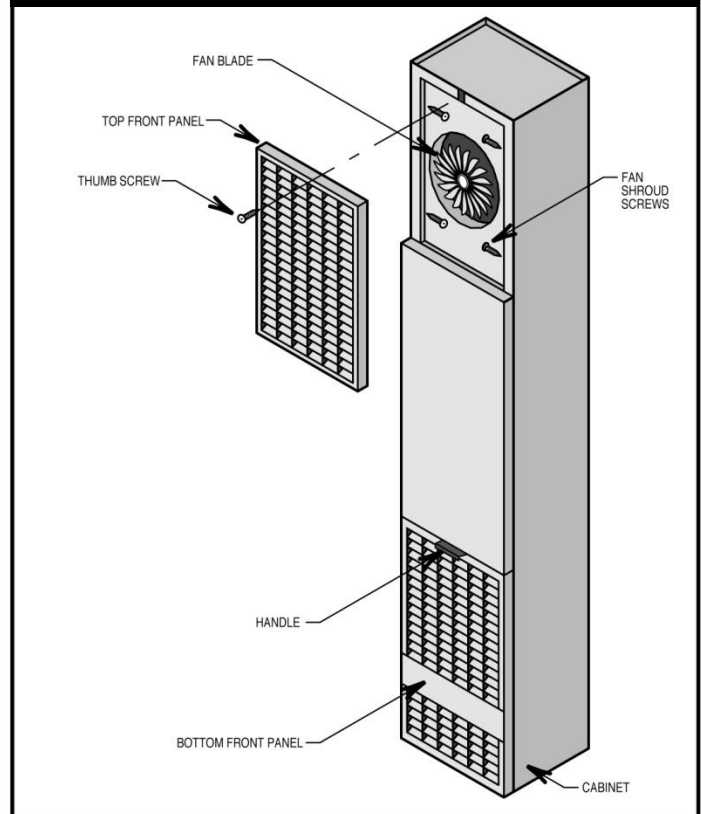

Installing Your Furnace

The following steps are needed for proper installation and safe operation of your furnace. If you have any doubts as to any requirements, always consult your local Heating or Plumbing Inspector, Building Department or Gas Utility Company regarding regulations, codes, or ordinances which apply to the installation of a vented wall furnace. Obtain professional help where needed.

The CHECK AND ADJUSTMENTS on page 24 are vital to the proper and safe operation of the furnace. Be sure they are done.

IMPORTANT

For satisfactory and trouble-free operation, be sure to:

Locating Wall Furnace & Thermostat

Consider the following points before attempting to install the furnace:

CAUTION: Do not make cut-outs in the wall or ceiling before checking in the attic for ceiling joist locations and proposed venting.

The counterflow vented wall furnaces are shipped ready to install on the surface of the wall or recessed up to 9-1/4 inches into the wall, with studs 16 inches center-to-center or stud space can be framed to 16 inches, see page 11, Recessed Mounting.

Place the furnace near the center of the space to be heated for good air circulation. Do not put it behind a door or draperies.

Do not install the furnace in a closet, alcove, or small hallway where the furnace could be isolated by closing doors to the heater space.

Do not install the furnace in a mobile home, trailer, or recreational vehicle.

The bottom of the furnace may rest directly on a wood or concrete floor. If floor is other than wood or concrete there must be a piece of wood or sheet metal under the furnace that is at least the same size as the bottom of the furnace.

On recessed installations the recessed portion may have 0 inches clearance to combustible material.

To provide adequate clearance and service access the front of the furnace must face the open room. Be sure that gas piping and electrical wiring can be brought to the location. See sections covering piping and electrical wiring for your type of furnace mounting.

Furnace vent must be installed directly to the outdoors so that combustion gases will not collect inside the building.

Provide an adequate vent or flue in accordance with local codes or ordinances and instructions provided by the vent pipe manufacturer.

Check the minimum spacing needs as shown on Page 7, Fig. 2 and Page 8, Fig. 3.

The top of the furnace must be at least 2 inches from the ceiling. See Fig. 2.

1. Locate the furnace properly within the space to be heated.
2. Install the furnace in accordance with local codes or ordinances and instructions provided. In the absence of local codes or ordinances, install the furnace to conform with the current edition of the National Fuel Gas Code, NFPA 54, ANSI Z223.1/Canadian Installation Code, CAN/CGAB149.
3. Maintain minimum clearance: Floor 0 inches or ceiling 2 inches, side wall 4 inches. For exception to minimum side wall clearance, as shown on Page 8, Fig. 3.
4. Provide enough combustion and ventilation air.

With standard furnace discharge outlet, do not install closer than 4 inches to intersecting wall. See figure as shown on Page 8, Fig. 3B.

When using optional kits 6703 or 6704 maintain clearances as shown on Page 8, Fig. 3A or 3C.

When using optional kit 6704 maintain clearance as shown in Figs. 3A and 3F, page 8. Use only optional outlet and grille kits available from manufacturer.

FIGURE 2 Minimum Clearances

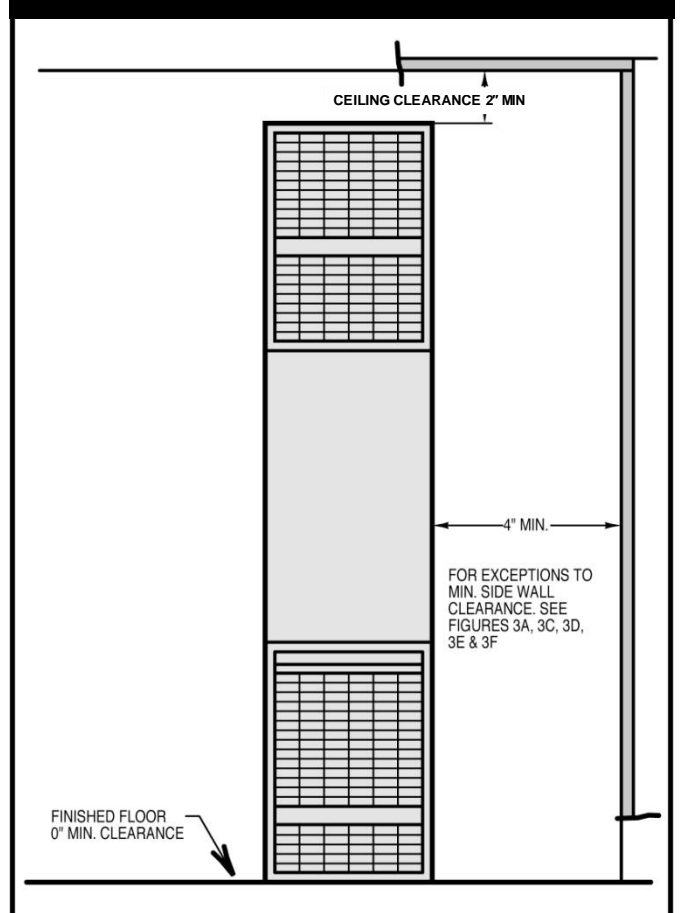

Installing Your Furnace

FIGURE 3 Minimum Clearances

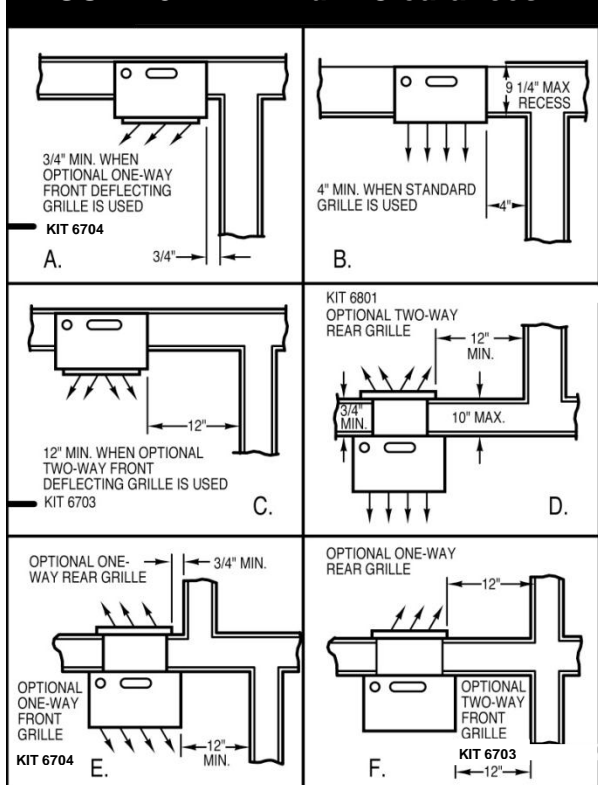

With standard furnace discharge outlet, do not install closer than 4 inches to intersecting wall.

Choose a location for the thermostat about 5 feet above the floor on an inside wall. The thermostat wire supplied with your furnace is 20 feet long, which should be enough to run up through the attic so the thermostat can be a maximum of 16 feet from the furnace measured in a straight line, or approximately 12 feet from the furnace if the wire is run under the floor. The thermostat should be sensing average room temperature, avoid the following:

HOT SPOTS:

- Concealed pipes or ducts
- Fireplaces
- Registers
- TV sets
- Radios
- Lamps
- Direct sunlight
- Kitchen

COLD SPOTS:

- Concealed pipes or ducts
- Stairwells – drafts
- Doors – drafts
- Unheated rooms on other side of wall

DEAD SPOTS

- Behind doors
- Corners, and alcoves

After picking a location that meets the requirements, check the walls, attic and roof to make sure there are no obstructions such as pipes, electric wiring, etc., which could interfere with the installation of the furnace or vent pipe. If required, move them or pick a new location.

WARNING: Danger of property damage, bodily injury or loss of life. Do not install furnace in any area where oxygen is in use.

Combustion & Ventilation Air

WARNING: Danger of property damage, bodily injury or loss of life. The furnace and any other fuel-burning appliances must be provided with enough fresh air for proper combustion and ventilation of flue gases. Most homes will require that outside air be supplied into the heated area.

The high cost of energy for home heating has brought about new materials and methods used to construct or remodel most current homes. The improved construction and additional insulation has reduced the heat loss and made these homes much tighter around windows and doors so that infiltrated air is minimal. This creates a problem to supply combustion and ventilation air for gas-fired or other fuel burning appliances. Any use of appliances that pull air out of the house (clothes dryers, exhaust fans, fireplaces, etc.) increases this problem and appliances could be starving for air.

In addition, these energy measures mean that your home will retain more water vapor or a higher relative humidity.

High humidity, especially during cold weather, may be damaging to buildings because condensation forms on windows and inside walls.

The combination of a tight energy efficient home with the use of exhaust fans, fireplaces, clothes dryers, and gas appliances result in more and more air being drawn from the house until fresh air may be sucked back into the house down a furnace flue or fireplace chimney. Carbon monoxide can be the result. Carbon monoxide (CO) is a colorless, odorless gas produced when fuel is not burned completely or when the flame does not receive sufficient oxygen. Automobiles, charcoal, wood fires and improperly vented or air-starved coal, oil and gas furnaces or other appliances can produce carbon monoxide.

Be aware of these air-starvation signals:

1. Headaches, nausea, dizziness.
2. Excessive humidity shown by heavily frosted windows or a moist "clammy" sensation.
3. Fireplace smoke fills the room or will not draw.
4. Furnace flue backs up.

Installing Your Furnace

AIR REQUIREMENTS

The requirements for providing air for combustion and ventilation are listed in the National Fuel Gas Code NFPA54/ANSI Z223.1 (in Canada: CAN/CGA B149). Most homes will require that outside air be supplied to the heated area by means of ventilation grilles or ducts connecting directly to the outside or spaces open to the outdoors such as attic or crawl space. The only exception is when the heated area meets the requirements and definitions for an unconfined space with adequate air infiltration.

WARNING: Danger of property damage, bodily injury or loss of life. The furnace and any other fuel-burning appliances must be provided with enough fresh air for proper combustion and ventilation of flue gases. Most homes will require that outside air be supplied into the heated area.

All air openings and connecting ducts must comply with the following:

If the furnace is installed in an area with another gas appliance(s), the total input rating of all appliances must be considered when determining the free area requirements for combustion and ventilation air openings.

Ducts must have the same cross-sectional area as the free area of the openings to which they connect. The minimum dimension of rectangular air ducts must not be less than 3-inches in length or height.

LOUVERS / GRILLES AND SCREENS COVERING FREE AREA OPENINGS

If a screen is used to cover the opening(s), it must not be smaller than 1/4-inch mesh. Use the free area of a louver or grille to determine the size opening required to provide the free area specified. If the free area is not known, assume a 20% free area for wood and a 60% free area for metal louvers or grilles.

EXAMPLE 1

FURNACE LOCATED IN UNCONFINED SPACE.*

*An unconfined space must have a volume of a minimum 50 cubic feet per 1000 Btu/hr. of total of all appliances in area. Adjoining rooms may be included only if there are no doors between the rooms, or if special provisions are made such as ventilation grilles installed between connecting rooms.

Fig 6, page 10 shows the minimum area in square feet based on 8 foot ceiling heights, required for different Btu/hr. input ratings.

A. If your furnace is in an open area (unconfined space*) the air that leaks through the cracks around doors and windows may be enough for combustion and ventilation air. The doors should not fit tight. The cracks around windows should not be caulked or weather stripped.

To determine if infiltration air is adequate, following checks:

1. Close all doors and windows. If you have a fireplace, start a fire and wait until flames are burning vigorously.

FIGURE 4 Draft Hood Spillage

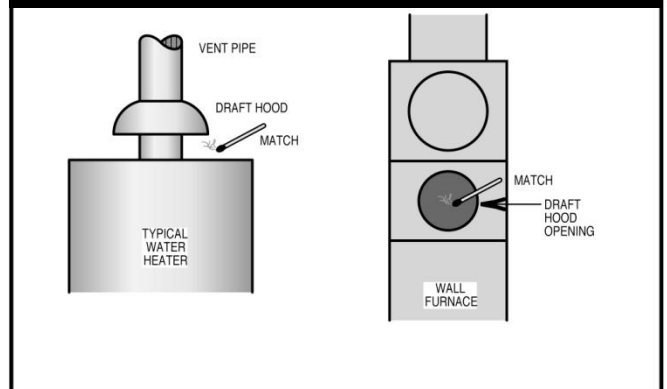

2. Turn on all exhausting devices, such as: kitchen and bathroom exhaust fans dryers (gas and electric)
 3. Turn on all vented gas appliances, such as: heating equipment (includes any room heaters) water heater
 4. Wait ten (10) minutes for drafts to stabilize.
 5. Check for draft hood spillage at each appliance. (Hold a lighted match 2 inches from draft opening. See Fig. 4.)
- B. No Spillage
- If the match flame pulls toward draft hood - this indicates sufficient infiltration air:
1. Return exhausting devices and appliances to the condition you found them.
- C. Draft Hood Spills
- If there is spillage at a draft hood (match goes out or flame wavers away from draft hood):
1. Check for plugged flue connectors and chimneys. Check and repair, stoppage and test again.
 2. If you have a fireplace, open a window or door near the fireplace and then check for spillage.
 - a) If spillage stops, do not use the fireplace without a nearby window or door open until you can supply fresh air by a permanent duct.
 3. If you have kitchen and bathroom exhaust fans, turn them off and check for spillage.
 - a) If spillage stops, do not use exhaust fans until you can supply fresh air by a permanent duct.

WARNING: Danger of property damage, bodily injury or loss of life. Draft hood spillage, with unobstructed vents, indicates that additional air must be brought into the structure from outside. Keep a window open (minimum 2 inches) near the appliance until a permanent air duct is installed.

Installing Your Furnace

4. Spillage means air starvation and a fresh air duct or air intakes must be installed to provide air directly to the furnace or other gas appliance.
- D. If spillage exists or when the furnace is in a building of tight construction where the windows and doors are weather-stripped, air for combustion and ventilation must be obtained from outdoors or space open to the outdoors.

Provide an opening(s) having a total free area of 1-square inch per 4000 Btu/hr. for the total of all appliances. The required area is shown on page 11, Fig. 9 under the column for (40,000).

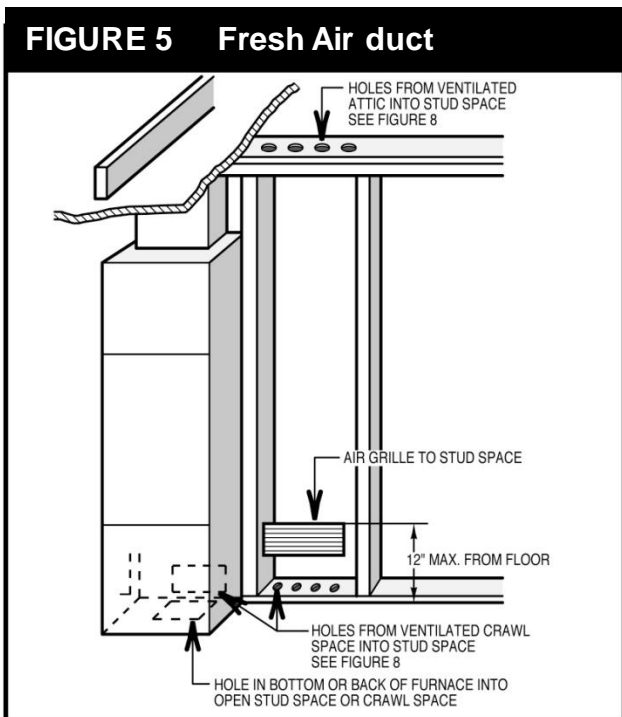

Fig 5 shows a typical duct going into ventilated crawl space or attic.

1. Duct must terminate at a point not more than 1 foot above the floor.
2. Duct size must be at least 1 inch of free area for each 4000 Btu/hr. of input of all appliances in area.

EXAMPLE 2.

FURNACE LOCATED IN CONFINED SPACE.

If furnace is installed in a confined space, it must be provided with free air for proper combustion and ventilation of flue gases by one of the following methods.

A. All Air From Inside Building:

If the confined space adjoins an unconfined, provide two permanent openings, one within 12 inches of the top and one

within 12 inches of the bottom of the room connecting directly to unconfined space. Each opening must have a free area of at least 100 square inches or 1 square inch per 1000 Btu/hr. combined input of appliances in one room if combined input exceeds 100,000 Btu/hr.

WARNING: Danger of property damage, bodily injury or loss of life. The adjoining unconfined space must have adequate air infiltration as defined in example 1.

FOR EXAMPLE: Your furnace is rated at 60,000 Btu/hr. The water heater is rated at 30,000 Btu/hr. The total is 90,000 Btu/hr. You need two grilles, each with 100 square inches of free opening. Metal grilles have about 60% free area, so you need two metal grilles each with 160 square inches of louvered area.

FIGURE 6 Minimum Area in Square Feet

4000 Btu/hr. Per Square Inch Opening		Max Btu/hr. Input	*Unconfined Space Min. Area In Sq. Ft. 8' Ceiling Height
Round Duct	Rectangular Duct		
4" DIA.	3"X3" SQ.	30,000	188
4" DIA.	3"X3" SQ.	35,000	219
4" DIA.	3"X4" SQ.	40,000	250
4" DIA.	3"X4" SQ.	45,000	281
4" DIA.	3"X5" SQ.	50,000	312
4 1/2" DIA.	3"X5" SQ.	60,000	375

* Can be two or more rooms joined by ventilation grilles.

Refer to figure as shown on Page 11, Fig. 7, which shows grille installation. Using the previous example, the two connecting rooms plus the closet must equal at least 500 sq. feet to handle the combined input 60,000 plus 30,000.

B. All Air From Outdoors:

If confined space doesn't adjoin an unconfined space then air must be provided from outdoors or spaces open to outdoors such as attic or crawl space.

Provide two permanent openings, one within 12 inches of top, one within 12 inches of bottom of room connecting directly, or by using ducts, with the outdoors or areas open to outdoors.

If opening connects directly to, or within vertical ducts, the free area of each opening must be at least 1 square inch per 4000 Btu/hr. combined input of appliances in area.

If horizontal ducts are used, the free area of each opening must be at least 1 square inch per 2000 Btu/hr. combined input of appliances in area.

Installing Your Furnace

FIGURE 7 Grilles Connecting Rooms to Make Unconfined Space

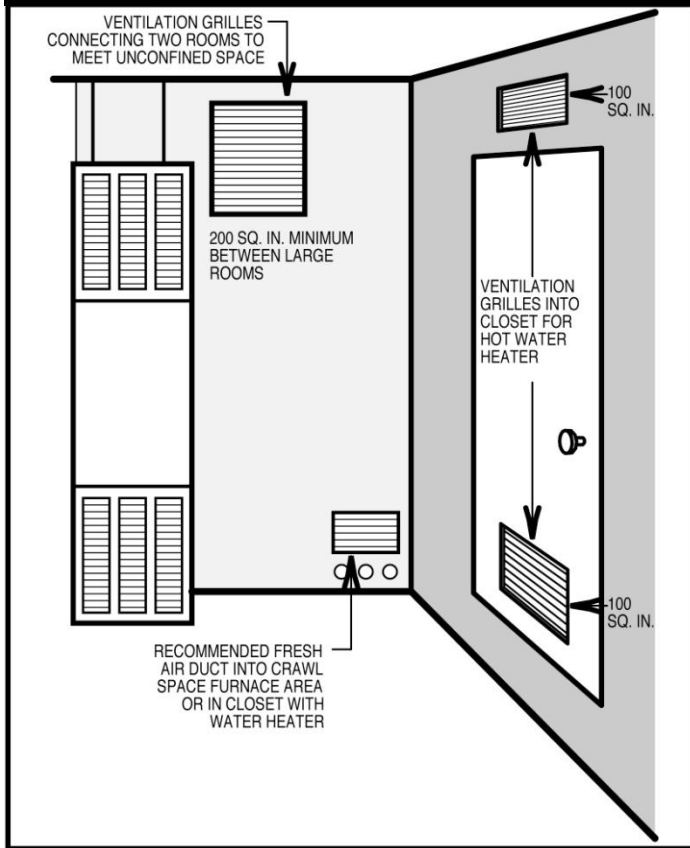

FOR EXAMPLE: Your furnace is rated at 60000 Btu/hr. The water heater is rated at 30,000 Btu/hr. The total is 90,000 Btu/hr. You need two grilles, each with 22½-square inches of free opening, unless connected by horizontal ducts which would require each grille or opening to have a free area of 45 square inches.

Recessed Mount Installation

FIND THE STUDS (See CAUTION on page 7)

Use a stud locator or small finishing nails. Repeatedly drive and remove a nail into the wall in the area of the stud until it is located. Then find the inside edge of the stud. Leave the nail at this location.

The other stud should be about 14½-inches from the one found. Drive finishing nails on the inside of this stud. Draw wall cutout to required size as shown on Page 13, Fig. 13. If wall studs are not on 16-inch centers see "CLOSE OFF STUD SPACE." (As shown on Page 12, Fig. 12).

CUT WALL OPENING

Provide an opening as shown on Page 12, Fig. 10. Work from the top in the attic to cut away the ceiling plate.

FIGURE 8 Air from Outdoors or Crawl Space

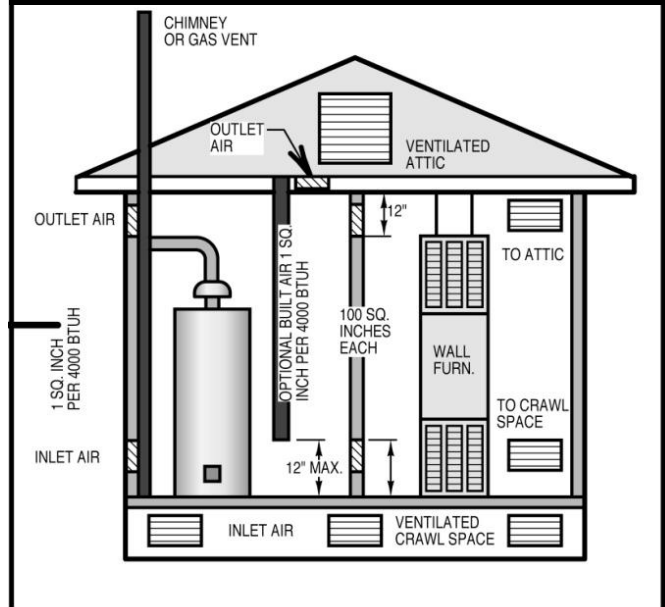

*Openings for inlet or outlet air should not be made into attic area if attic is equipped with a thermostat controlled power vent.

FIGURE 9 Free Area

Furnace Btu/hr./Input	Sq. Inch of Opening	Req'd Number of Holes Sill or Header Plates		
		1 1/2"	2"	3"
30,000	7.5	7	4	2
35,000	8.75	8	5	2
40,000	10.0	9	5	3
45,000	11.25	10	6	3
50,000	12.5	11	6	3
60,000	15.0	13	8	4

Shown in square inches – each opening (furnace only)
Based on one square inch per 4000 Btu/hr.

WARNING: BEFORE INSTALLING: To avoid electrical shock, turn off electrical circuits that pass through the wall where you are going to install the furnace.

ATTACH HEADER PLATE

MODELS: 6008531;6008532

Locate header plate between wall studs at 81 3/4 inches from finished floor and nail into position with end flanges pointing up. Make sure header plate is level.

ALL MODELS

Hole or electrical conduit is located on left side of header plate as you face the wall.

Installing Your Furnace

WARNING: Remove 4"x14" fiberglass gasket from bottom of header plate and discard. This gasket is not used when the furnace is recessed in the wall.

FIGURE 10

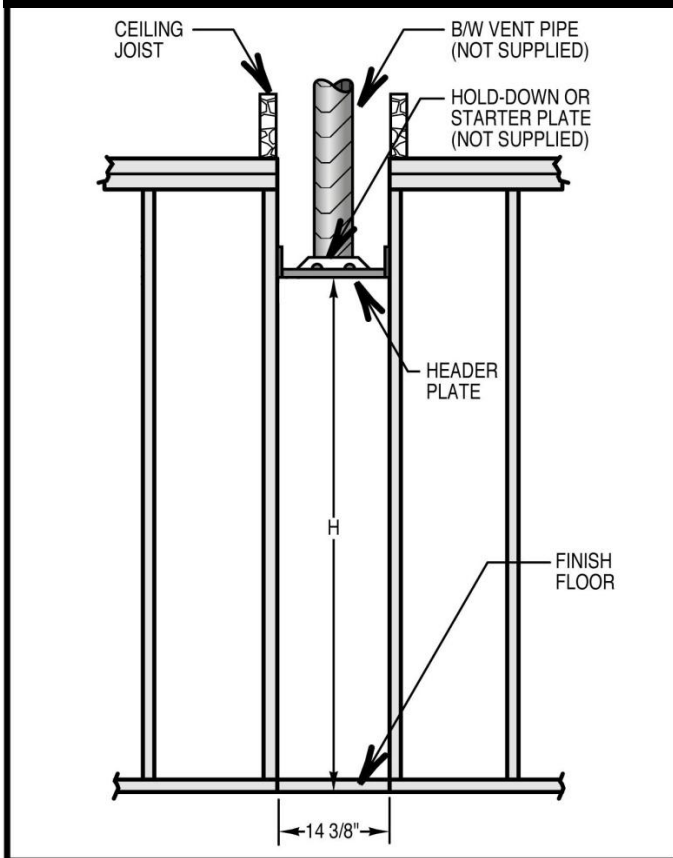

GAS SUPPLY OPENING

A hole must be drilled for the gas line supply.

Decide whether the gas line will come through the floor or wall stud.

NOTE

If a pre-existing gas piping stub location is not compatible with hole or knock-out provided in furnace, you may make an alternate entry hole in furnace back wall as shown on Page 14, Fig. 14.

CAUTION: Be careful not to damage any furnace components while making any alternate hole.

Locate and drill one (1) 1-1/2 inch hole at selected locations as shown on Page 12, Fig. 11 and Page 13, Fig. 13 or Page 14, Fig. 14.

Gas line can be run at this time or done after furnace is mounted, see section GAS SUPPLY AND PIPING, page 18.

FIGURE 11

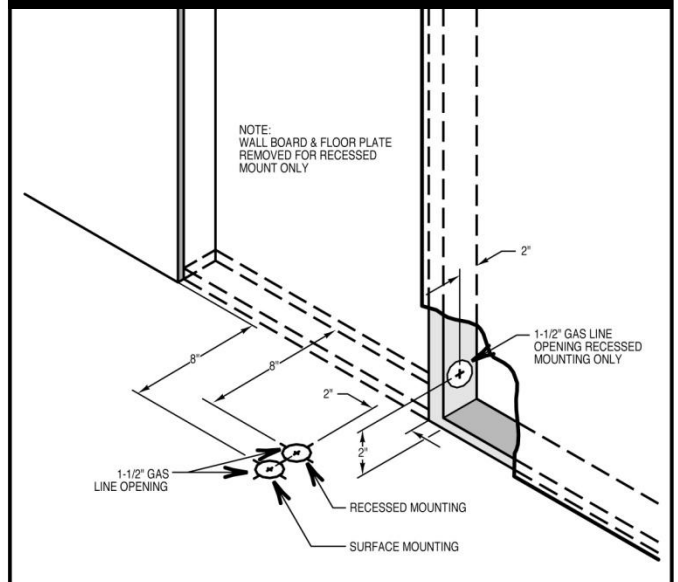

CLOSE OFF STUD SPACE (If Required)

If studs are not on 16 inch centers, cut the hole for the furnace next to an existing stud and frame in the other side using a 2 x 4 and spacer blocks as required. As shown on Page 12, Fig. 12.

ELECTRICAL SUPPLY ROUGH-IN

Run the electrical supply with the ground wire and thermostat cable into stud space next to furnace location.

FIGURE 12 Closed Off Stud Space (If Required)

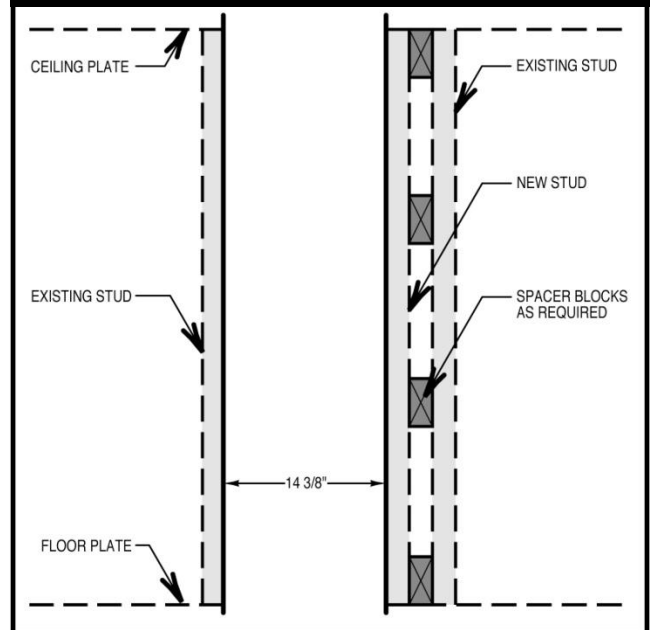

Installing Your Furnace

CAUTION: Do not run wire behind flanges of header plate or in any location where it might be damaged. Avoid splicing thermostat wire unless the spliced wires are properly cleaned, soldered and taped.

FIGURE 13 Knockout Dimensions

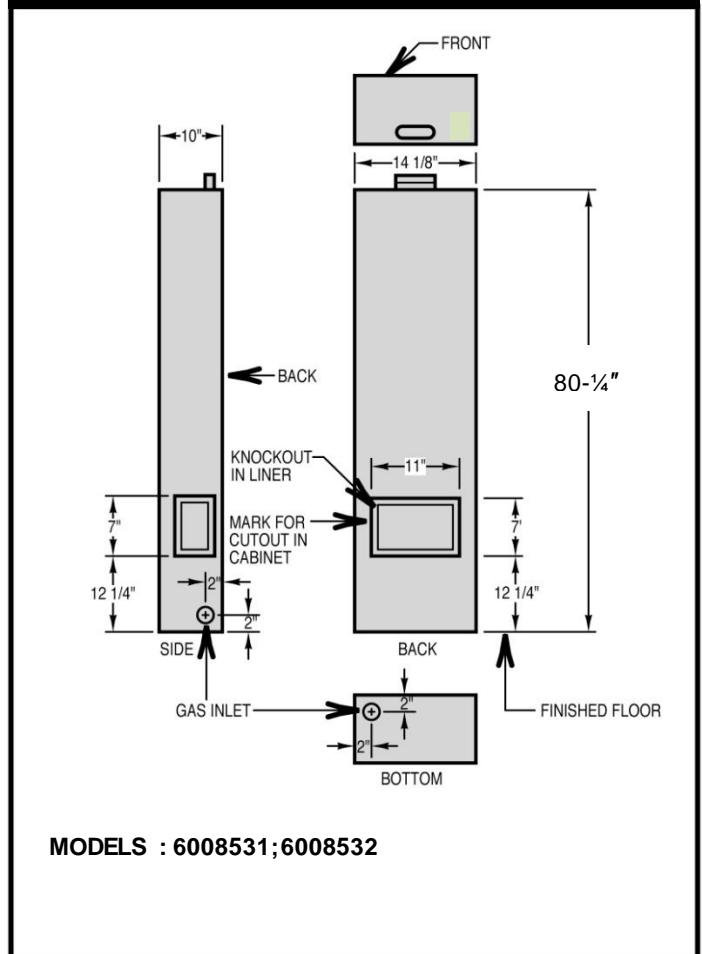

Surface Mount Installation

FIND THE STUDS AND CEILING JOISTS (See CAUTION on page 7)

Find two studs at spot where furnace is to be placed. Use a stud indicator or small finishing nails. Repeatedly drive and remove a nail into the wall in the area of the stud until you find it. Then find one side. Leave the nail there. Drive another nail just on the other side of the same stud.

Inside edge of the other stud should be about 14-1/2 inches from the one found. Drive finishing nail on inside edge of this stud.

Using the nails as a guide, draw a line up both sides to the ceiling to locate hole cut out for vent pipe and electrical connections.

CUT CEILING OPENING

Mark off and cut 3-1/2 x 12 inch rectangular hole in ceiling, centered between wall studs. The back edge of the opening should be about 1/8 inch from the wall. As shown on Page 15, Fig. 16.

ELECTRICAL SUPPLY ROUGH-IN

The electrical supply openings must be made in the wall or floor below furnace to match holes in furnace bottom. See Fig. 13.

If desired, the power supply and thermostat cable can come into the wall stud space from a basement, crawl space or an adjoining stud space.

At selected location, drill a 1-inch hole for 115V power supply and a 1/2 inch hole for the thermostat cable.

Run wiring through the holes to the furnace leaving enough excess wire to make electrical connections after mounting furnace.

CAUTION: To avoid damage to wiring, be sure to route wire away from path of furnace vent.

GAS SUPPLY OPENING

A hole may need to be drilled for the gas line supply.

Decide whether the gas line will come through the floor or wall.

Installing Your Furnace

NOTE

If you decide to route gas line through right side of furnace, simply remove the knock-out provided in furnace side.

NOTES

If a pre-existing gas piping stub location is not compatible with hole or knock-out provided in furnace, you may make an alternate entry hole in furnace back wall per Fig. 14.

CAUTION: Be careful not to damage any furnace components while making any alternate hole.

Locate and drill one (1) 1-1/2 inch hole at selected location as shown on Page 12, Fig. 11; Page 13, Fig. 13, or Fig 14.

Gas line can be run at this time or done after the furnace is mounted, see section CONNECTING GAS LINE.

FIGURE 14 Alternate Gas Supply Opening

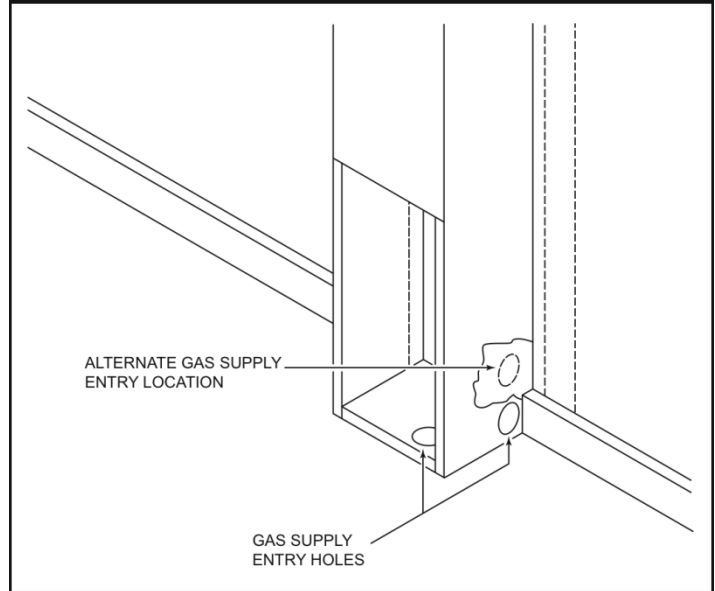

Vent Installation

The vent installation must comply with all local codes and ordinances. If in doubt, consult your local codes or inspector.

The furnace vent must be directed to the outdoors so that harmful combustion gases will not collect inside the building.

This furnace must not be connected to a chimney flue serving a separate solid-fuel burning appliance.

Use U.L. listed B/W Vent Kit 9901. You must provide other items, not contained in the kit, necessary to complete your specific venting situation through the roof. Refer to typical venting system as shown on Page 16, Fig. 18.

Type B/W gas vent shall extend from the header plate of the vented wall furnace to a point above the highest ceiling plate within a stud space through which the vent passes, without any offsets or crossovers therein. After a type B/W gas vent passes through the highest ceiling plate within a stud space above the furnace which it serves, the vent system may be completed with a type B vent, of the same manufacturer, and offsets or break over, shall not be greater than 45 degrees from vertical. Maximum of two.

NOTE

The B/W vent must extend through the ceiling and roof terminating at least 12 feet above the finished floor on which the furnace rests.

First vent pipe offset (if required) is recommended not to be any closer than 4'-0" from header plate.

ATTACH HEADER & HOLD-DOWN PLATE (SURFACE MOUNT)

Remove the fiberglass flue collar from the furnace flue extension. This gasket is not used when the furnace is surface mounted.

Make sure that the 4 x 4 inch gasket is in position on the header plate.

Slide header plate over the furnace flue extension.

Refer to Fig. 15.

Fasten to matching holes in the furnace top through holes "A" in the header plate, using two (2) #8 x 3/8 inch screws provided.

FIGURE 15

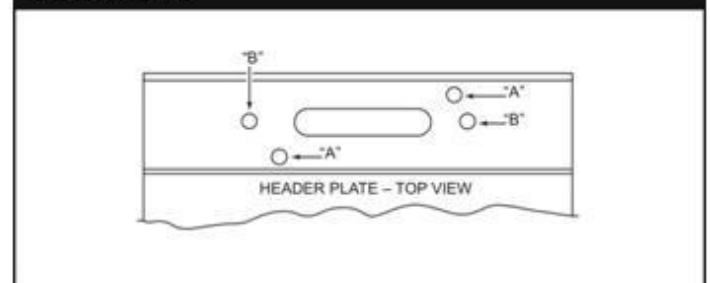

Fasten the hold-down plate or starter plate to the top of the header plate using holes "B" in the header plate.

Installing Your Furnace

ALL MODELS

ATTACH HOLD-DOWN PLATE

NOTE

Header plate should already be attached.

Fasten hold-down plate to top of header plate using two (2) screws provided.

FIGURE 16

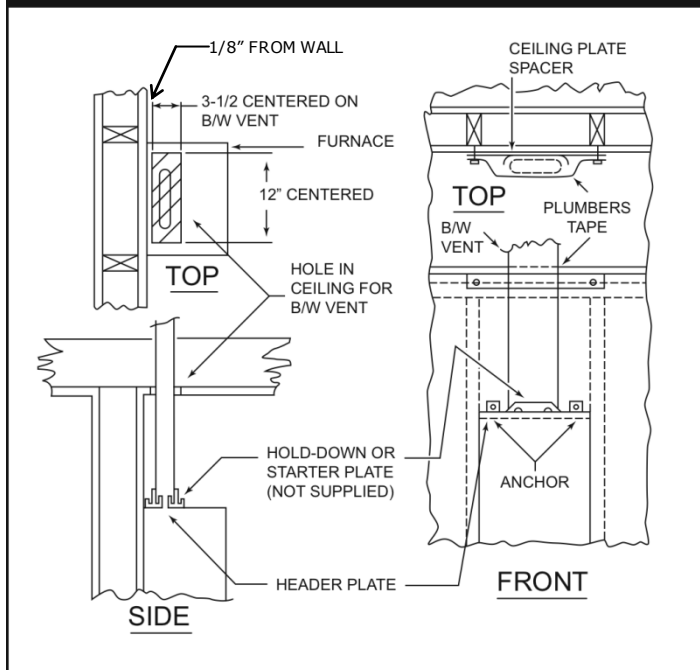

INSTALL CEILING PLATE SPACERS (SURFACE MOUNT)

Refer to Fig. 16.

Only one (1) plate spacer is required for surface mounting within a single story dwelling.

Cut 2 inches off each end of plate spacer.

Drill two (2) 3/16 inch holes in each end of plate spacer as shown in Fig. 16.

Fasten plate spacer to wall by nailing through one (1) drilled hole in each end, into the wall board and ceiling plate.

INSTALL CEILING PLATE SPACER (RECESSED MOUNT)

Refer to Fig. 17.

Two ceiling plate spacers are in the B/W vent kit 9901. They must be fastened along each long edge of the ceiling hole to hold the oval vent pipe in the center of the hole.

Nail the ceiling plate spacers either across or in between the cut out section of ceiling plate. If nailed between, ends must be bent at 90 degrees.

FIGURE 17 Ceiling Plate Spacers

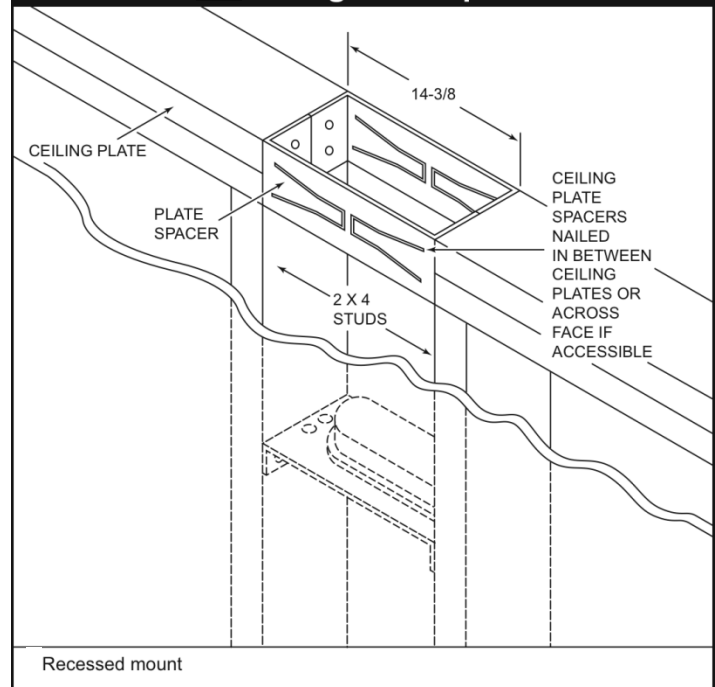

INSTALL SURFACE VENT (SURFACE MOUNT)

NOTE

For surface mounting, it will be helpful to complete the gas piping supply to the furnace before installing the vent pipe. See section GAS SUPPLY & PIPING, page 18.

Carefully move the furnace into position under the ceiling cutout.

Insert 4 foot length of oval, double wall vent pipe up through the ceiling cutout. Lower vent pipe to the hold-down plate. Push the vent pipe into the hold-down plate until it is completely seated. (Hold-down cleats will engage the groove in the vent pipe.)

Secure hold-down plate to vent pipe using two (2) screws.

Using plumbers tape to secure vent to the plate spacer, nail through one (1) hole in each end of plate spacer, into the wall and ceiling plate.

INSTALL FURNACE VENT (RECESSED MOUNT)

Lower a 4 foot length of oval, double wall vent pipe through the plate spacers to the hold-down plate.

Push the vent pipe into the hold-down plate until it is completely seated. (Hold-down cleat will engage the groove in the vent pipe.)

Secure hold-down plate to vent pipe using two (2) screws.

Installing Your Furnace

COMPLETE THE VENTING

Refer to Fig. 18.

Install oval to round adapter. Complete the piping extending it through the roof. Use 4" round, double wall (Type B) vent pipe, roof flashing, storm collar, and vent top as shown. The vent cap must be at least 2 feet higher than any point that is within 10 feet horizontally of the vent cap. There must be at least 1 inch clearance between the vent pipe and any combustible material.

IMPORTANT

Area above header within the stud space MUST be kept clear of any attic insulation to allow the free circulation of air around oval vent piping.

FIGURE 18 Typical Vent Installation

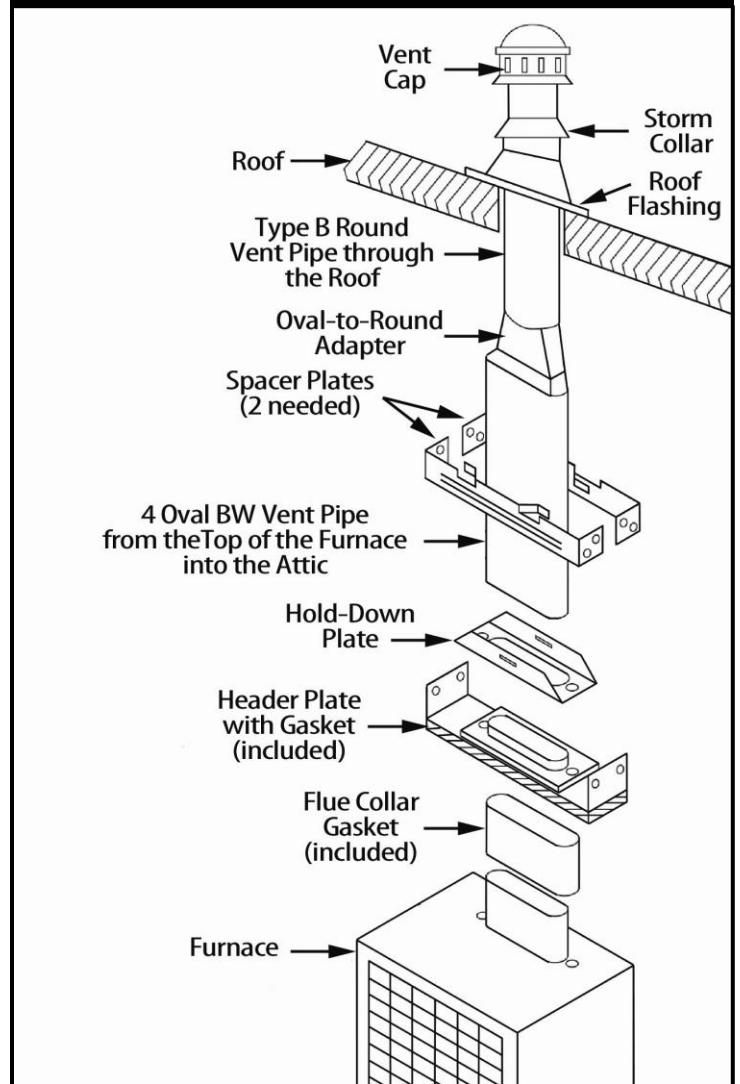

Mounting Your Furnace

To obtain adequate clearance for fastening furnace or to install gas supply fittings, it may be necessary to remove the burner and control assembly as follows:

Remove burner compartment door by pulling door top out and up.

Locate the air discharge shield. It is secured across the top of the burner control compartment. Remove two (3) screws and shield and set aside. Refer to Page 31, item #3.

DISCONNECT WIRING

MODELS: 6008531;6008532

Disconnect two (2) slip-on connectors (24 volt wires) from the gas valve. Disconnect two (2) slip-on connectors from junction block midway on the thermocouple.

Installing Your Furnace

REMOVE BURNER AND CONTROLS

Locate the burner and hex nuts that secure it. Remove the two (2) hex nuts (one from each end). Lift one end of the burner at a time until free. Remove burner and controls from the compartment.

POSITION FURNACE (RECESSED MOUNT ONLY)

NOTE

If your furnace is surface mounted, your mounting was started during VENT INSTALLATION, page 14. To complete furnace mounting, go on to FASTEN FURNACE BOTTOM on this page.

POSITION FURNACE (RECESSED MOUNT ONLY)

Make sure that the flue collar gasket, as shown on Page 16, Fig. 18, is in place over the flue extension. Check to see if header plate gaskets are in place.

Hold the furnace at a slight angle (top closer to the wall than bottom) with the flue extension centered under the oval hole in the header plate.

ALL MODELS (RECESSED MOUNT)

Lift furnace up so that the flue extension enters the oval hole in the header plate.

Straighten the furnace by pushing furnace bottom into the stud space.

ALL OTHER MODELS

IMPORTANT

AFTER FURNACE HAS BEEN PLACED IN POSITION, MAKE SURE THE GASKETS ARE PRESSING AGAINST THE FURNACE TOP TO ELIMINATE AIR LEAKS.

FASTEN FURNACE BOTTOM (SURFACE AND RECESSED MOUNT)

NOTE

Fasteners are not furnished because of different requirements of various types of wall construction.

Fasten furnace to floor through holes provided in furnace bottom. If you have concrete flooring, use an alternate fastening method. See Fig. 19.

If burner and control assembly were removed, replace them by reversing "DISCONNECT WIRING" and "REMOVE BURNER AND CONTROLS" sections on page 17.

FIGURE 19 Furnace Mounting

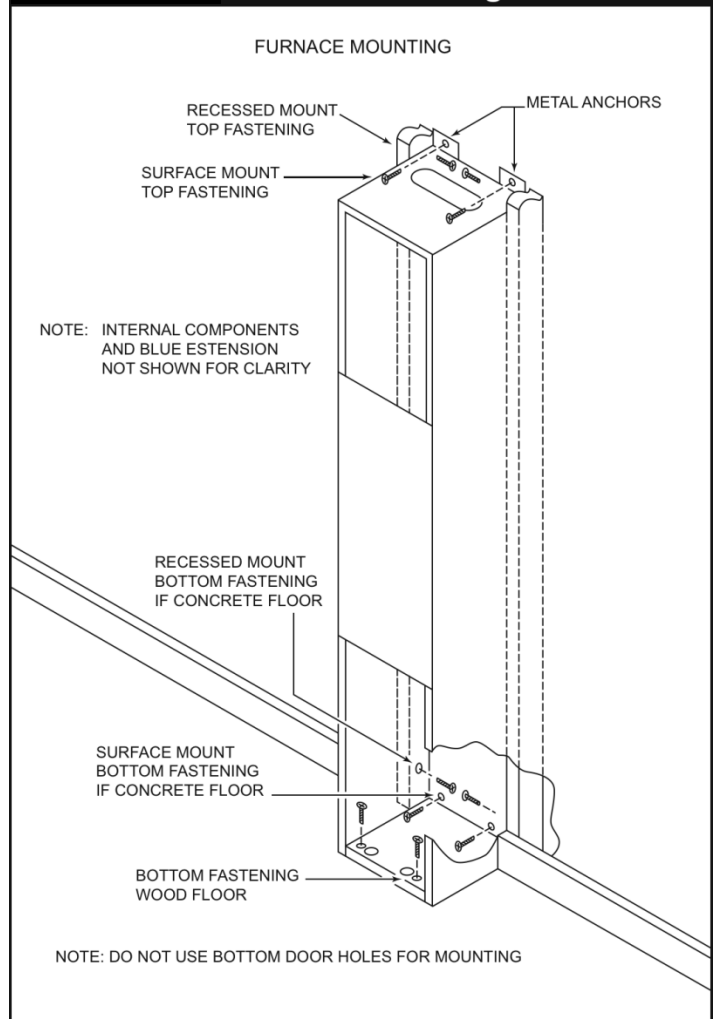

IMPORTANT

TO PREVENT DAMAGE TO WIRING, MAKE SURE NOT TO PINCH THE WIRES BETWEEN FURNACE COMPONENTS. KEEP THEM ROUTED AWAY FROM THE BURNER.

Re-secure the air discharge shield across the top of the burner and controls compartment. Small leg of "L" shape must be positioned toward floor, pointing away from front of furnace. Refer to Page 31, item #3.

FASTEN FURNACE TOP (SURFACE MOUNTING)

Fasten furnace top to wall using two (2) metal anchors (packed in plastic bag with thermostat) by placing them over the back flange of furnace top and screwing to wall. See Fig. 19.

FASTEN FURNACE TOP (RECESSED MOUNTING)

Fasten furnace top by drilling two (2) holes through the side flanges of furnace top and securing with two (2) screws or nails into the wall studs. See Fig. 19.

CAUTION: Be careful not to damage furnace components or wiring when drilling holes.

Installing Your Furnace

Gas Supply and Piping

Gas control valve, within the furnace, is shipped with a seal over gas inlet tapping. Do not remove seal until ready to connect piping.

WARNING: Danger of property damage, bodily injury or death. Make sure the furnace is equipped to operate on the type of gas available. Models designated as natural gas are to be used with natural gas only. Furnace designated for use with liquefied petroleum (L.P.) gas rate orifices sized for commercially pure propane gas. They cannot be used with butane or a mixture of butane and propane.

GAS SUPPLY

For Natural gas, the minimum inlet gas supply pressure for the purpose of input adjustment is 5" water column. The Maximum inlet gas supply pressure is 7" water column.

For L.P. gas, the minimum inlet gas supply pressure for the purpose of input adjustment is 11" water column. The maximum inlet gas supply pressure is 13" water column.

Gas pressure and input to the burners must not exceed the rated input and pressure shown on the rating plate. On Natural Gas the manifold pressure should be 4 inches water column. The manifold pressure should be 10 inches water column for L.P. Gas. See page 24 for operation above 2000 feet altitude. Orifice change may be required to suit gas supplied. Check with your local gas supplier.

ORIFICE SIZES

Furnace Technical Information, page 28, shows the correct orifice sizes for the different input ratings when using Natural or L.P. Gas.

GAS PIPING

The gas supplyline must be of adequate size to handle the Btu/hr. requirements and length of the run for the unit being installed.

Determine the minimum pipe size from Page 19, Fig. 22, basing the length of the run from the gas meter or source to the unit.

FIGURE 20 *Left Side Gas Inlet

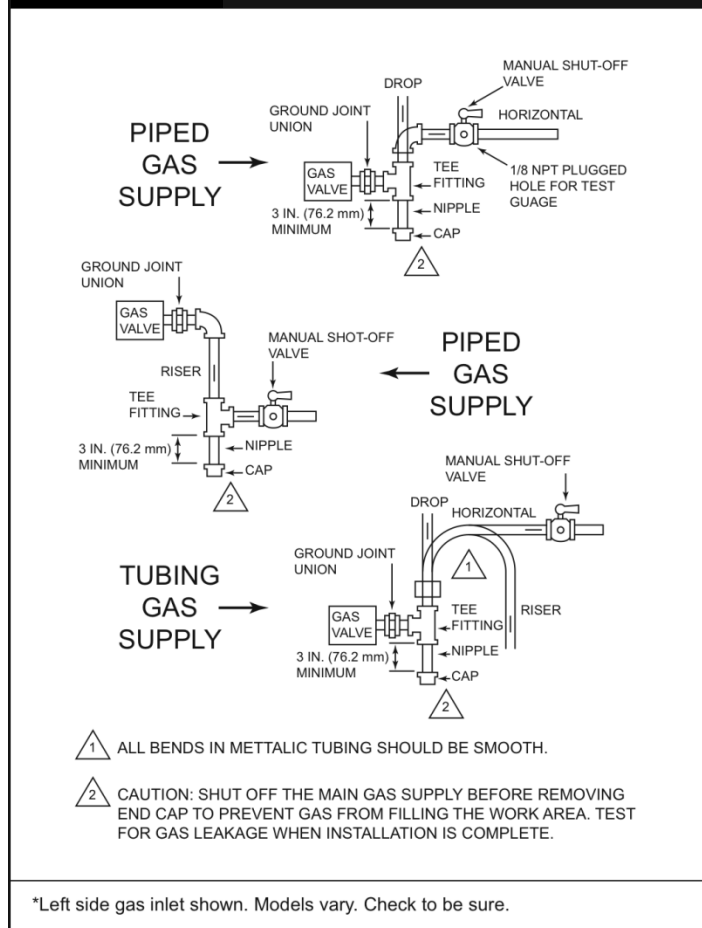
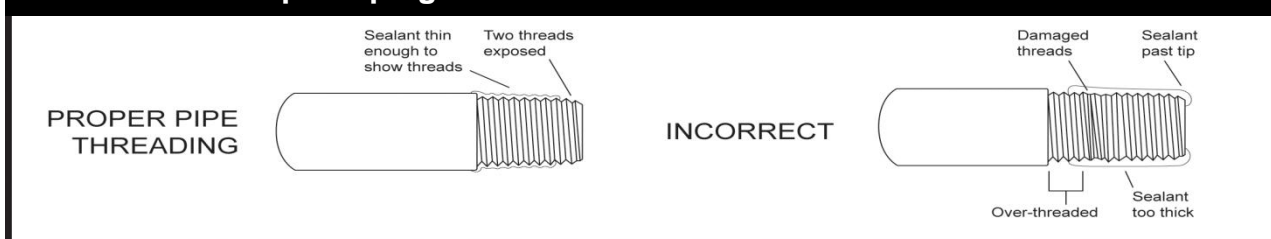

FIGURE 21 – Proper Piping Practice



All piping must comply with local codes and ordinances or with the National Fuel Gas Code (ANSI Z223.1), whichever applies. In Canada: Follow CAN 1-B149 Installation Code.

Refer to Page 18, Fig. 20, for the general layout at the unit. It shows the basic fittings needed.

Installing Your Furnace

The following rules apply:

1. Use new, properly reamed pipe free from metal chips and debris such as steel or black iron pipe. Use fittings approved by local codes.
2. Do not thread pipe too far. Valve distortion or malfunction may result from excess pipe within control. Apply moderate amount of good quality dope to pipe only, leaving 2 end threads bare. If LP Gas installation, use compound resistant to action of liquefied petroleum gases.
3. Use ground joint unions.
4. Install a drip leg to trap dirt and moisture before it can enter the gas valve. Drip leg must be a minimum of 3 inches long.
5. Install a manual shut-off valve.
6. Provide a 1/8" NPT test gauge connection immediately before the gas supply connection to the furnace.

GAS CONNECTION

If installation is for L.P. Gas, have L.P. installer use two-stage regulation and make all connections from storage tank to furnace.

Use two pipe wrenches when making the connection to the valve to prevent turning or damage to gas valve.

Connections between the manual shutoff valve and burner control assembly can be made with an A.G.A./C.G.A. design certified flexible connector if allowed by local codes. Drip leg and ground joint unions are still required.

Tighten all joints securely.

CHECKING THE GAS PIPING

Test all piping for leaks. When checking gas piping to the furnace with gas pressure less than 1/2 PSI, shut off manual gas valve to the furnace. If gas piping is to be checked with the pressure at or above 1/2 PSI, the furnace and manual shut off valve must be disconnected during testing. (SEE WARNING.) Apply soap

solution to each joint. Bubbles forming indicate a leak. Correct even the slightest leak at once.

FIGURE 22 Gas Pipe Sizes

NATURAL GAS PIPE CAPACITY – Btu/hr. (INCLUDES FITTINGS) PIPE SIZE			
LENGTH OF PIPE – FEET	1/2 INCH	3/4 INCH	1 INCH
20	92,000	190,000	350,000
40	63,000	130,000	245,000
60	50,000	105,000	195,000
L.P. GAS PIPE CAPACITY – Btu/hr. (INCLUDES FITTINGS)			
LENGTH OF PIPE – FEET	1/2 INCH	3/4 INCH	1 INCH
20	189,000	393,000	732,000
40	129,000	267,000	504,000
60	103,000	217,000	409,000

WARNING: Danger of property damage, bodily injury or loss of life. Never use a match or open flame to test for leaks. Never exceed specified pressures for testing. High pressures may damage the gas valve and cause over-firing which may result in heat exchanger failure. Liquid petroleum (L.P. Gas) is heavier than air and it will settle in any low area, including open depressions and it will remain there unless area is ventilated. Never attempt startup of unit before thoroughly ventilating area.

Electrical Wiring

The appliance, when installed, must be electrically grounded in accordance with local codes, or in the absence of local codes, with the National Electrical Code (ANSI/NFPA 70) or Canadian Electrical Code (CSA C22.1), if an external electrical source is utilized. This appliance is equipped with a three-prong (grounding) plug for your protection against shock hazard and should be plugged directly into a properly grounded three-prong receptacle. Do not cut or remove the grounding prong from this plug.

ELECTRICAL SUPPLY

Remove three-prong (grounding) service cord from the envelope parts package to install in the furnace. Remove 7/8" diameter (22mm) knockout at the left or right bottom side panel to route the three-prong service cord to an electrical outlet.

1. Insert the nylon cap attached to the end of the three-prong service cord thru the 7/8" diameter (22mm) knockout into the burner control assembly area and insert it into the nylon plug attached to the outer casing bottom. If desired, you may route

the thermostat wire alongside of the service cord and thru the same opening or choose another entry into the burner control assembly area.

2. Attach 7/8" diameter (22mm) strain relief around the three-prong (grounding) service cord and the thermostat wire (if thermostat wire is routed thru knock-out). Insert the 7/8" (22mm) strain relief into the 7/8" (22mm) hole in the side panel of furnace.

WALL THERMOSTAT WIRING

Run thermostat wire to the furnace.

Avoiding splicing thermostat wire unless the spliced wires are properly cleaned, soldered and taped.

Connect the thermostat to the two wires marked "Thermostat" extending from top of furnace, using two wire nuts provided. See Wiring Diagrams, page. 30.

Installing Your Furnace

Thermostat Installation

1. If an old thermostat is being replaced and is in a satisfactory location and the wiring appears to be in good condition, use existing wiring. If in doubt, use new wire.
2. If a new location is chosen or if this is a new installation, thermostat cable must first be run to the location selected. All wiring must agree with local codes and ordinances. These instructions cover bringing the wire down from the attic but it can be run from a basement or crawl space using similar methods. Refer to Fig. 23.
3. Before drilling a hole in the wall at selected location, drive a small finishing nail through the ceiling in the corner of the wall and ceiling above the thermostat location. Pull the nail out and push a small stiff wire through the hole so it can be found in the attic. Drill a 1/2 inch hole through the ceiling wall plate.
4. Probe for obstructions in the partition. Then drill a 1/2 inch hole through wall at the selected location for thermostat.
5. From the attic, feed the thermostat cable or a stiff wire through wall until even with thermostat location.
6. Snag thermostat cable through hole and pull cable through hole in wall so that 6 inches of cable protrudes.
7. Route cable to wall furnace.

MOUNTING THE THERMOSTAT

1. To remove thermostat cover, squeeze both sides and lift. Carefully remove and discard the packing tab protecting the switch contacts. See Fig. 24.
2. Connect the thermostat wires to the terminal screws on the thermostat base.
3. Push any excess wire back through hole in wall and plug hole with insulation to prevent drafts from affecting thermostat operation.
4. Being sure to level the thermostat for best appearance, fasten the thermostat base to the wall through mounting holes with screws provided.
5. Replace the thermostat cover.

FIGURE 23 Route Thermostat Cable

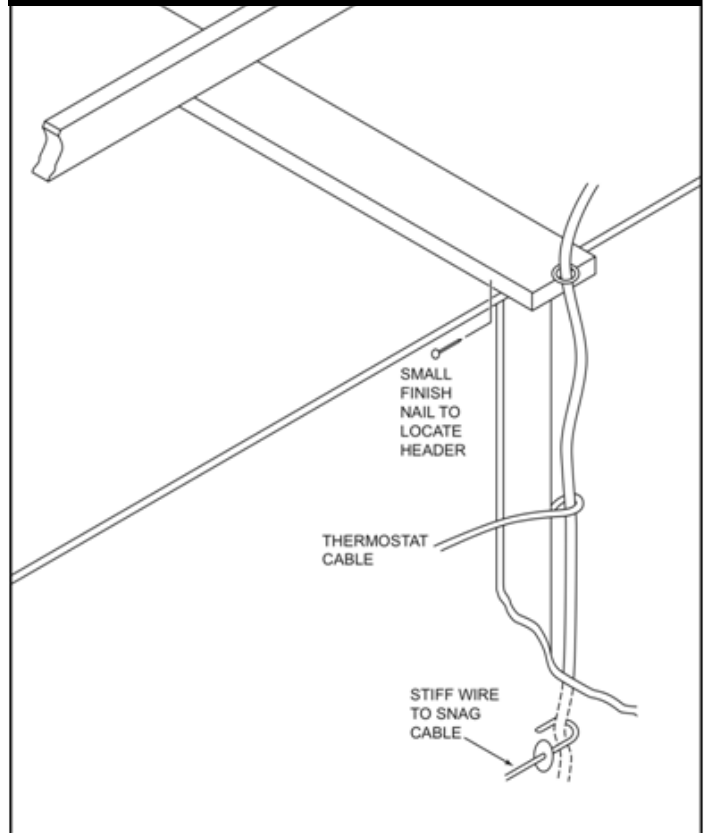
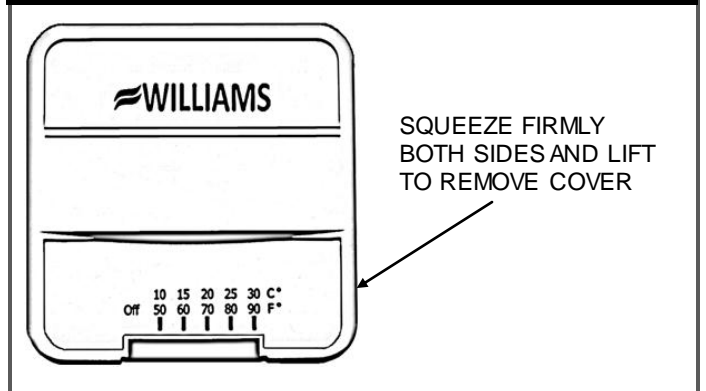

FIGURE 24 Thermostat



NOTE: Use heavier wire size if more than 20 ft. of wire is required.

Installing Your Furnace

Optional Accessory Installation

SIDE OUTLET MODEL 6701

REAR OUTLET MODEL 6801

SHORT REAR OUTLET MODEL 6802

CAUTION: Use only Boots and Grilles provided by the manufacturer.

CLEARANCES

IMPORTANT

Carefully follow all measurements and clearances given to ensure proper installation.

When SIDE OUTLET MODEL 6701 is used, the furnace casing must be a minimum of 4 inches from an adjacent side wall (except may be 3/4" minimum when 1-WAY FRONT DIFFUSING GRILLE is used). See Fig. 26 and Fig 27.

When REAR OUTLET MODEL 6801 or SHORT REAR OUTLET MODEL 6802 is used, the furnace casing must be a minimum of 12 inches from an adjacent side wall as shown on Page 8, Fig. 3D.

CUT CASING OPENING(S)

Before setting the furnace into position, cut a 5x7 inch rectangular opening for Side Register, or 7x11 inch opening for a Rear Outlet Register where marked on the furnace casing. Cut carefully as edges must be straight and smooth. See Page. 13, Fig 13.

CUT WALL OPENING(S)

Make an opening(s) in the wall(s) for a Side and/or a Rear Outlet Register. See Fig. 25.

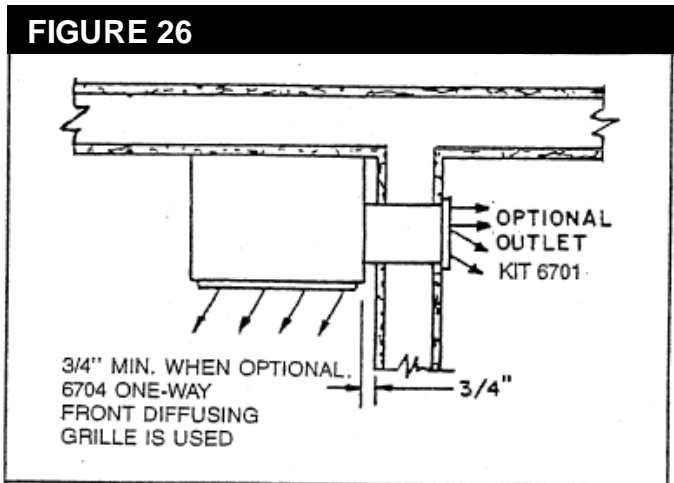

INSTALL PLASTERGROUNDS

Install plastergrounds as shown in Fig. 27 and Fig. 28. Flanges of plastergrounds extend the normal thickness of plaster. If "DRYWALL" or other thin material, flanges must be trimmed off flush with wall surface.

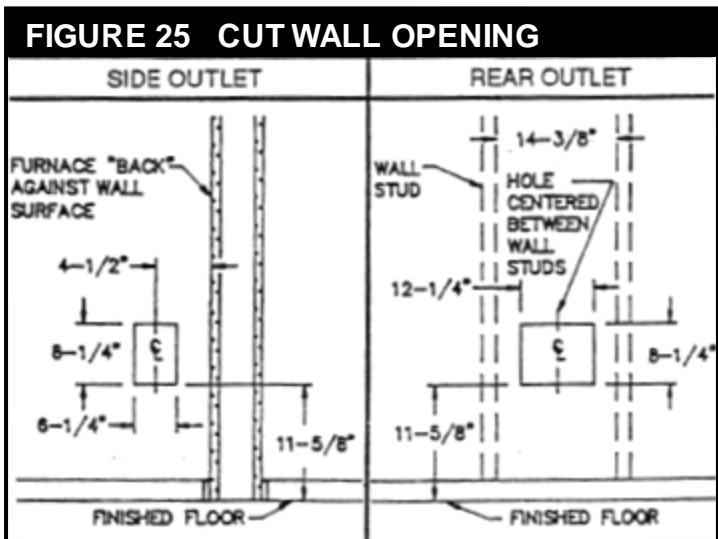
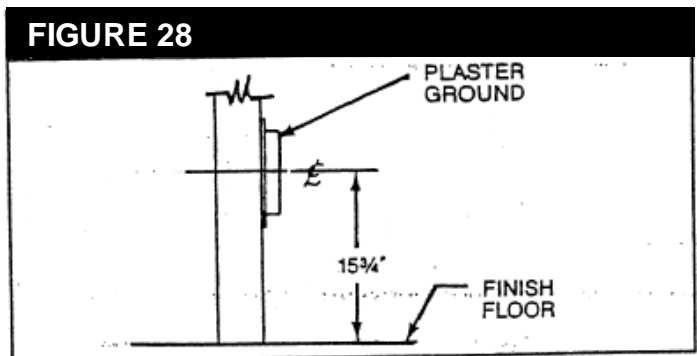
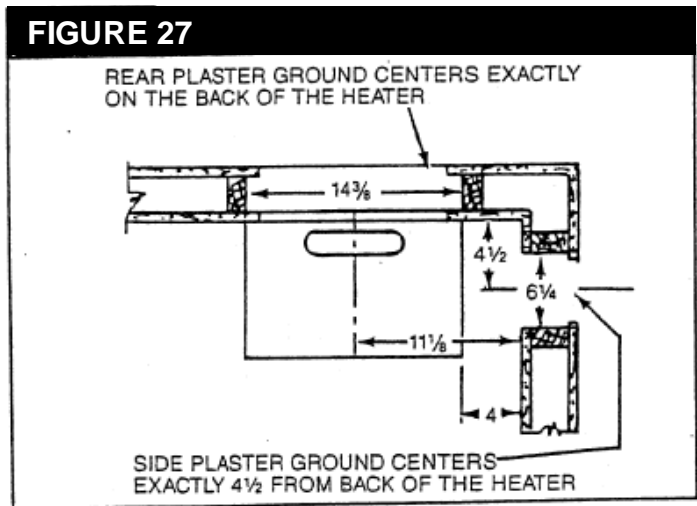

Installing Your Furnace

MOUNTING

Refer to Fig. 29.

BEFORE placing the furnace into position, place Out Boot against the furnace casing with inside of flanges exactly on edges of the hole in casing. Mark hole locations on casing through the holes in Out Boot flanges.

Drill #33 holes in casing at marked locations.

Remove knockout plate and knockouts for screws from Inner Liner.

SIDE REGISTER ONLY

Secure a 1x1 inch wood strip (not included in this kit) to wall surface next to side outlet as a backup for metal filler strips.

Fasten metal filler strips to side of furnace casing with front surface exactly opposite front of wood backup strip.

SIDE AND REAR OUTLET REGISTERS

Place furnace in Position.

With furnace in position, pass outer Boot through Plastergrounds, holding it firmly against furnace casing. Mark and cut off the end of the Outer Boot flush with the wall surface.

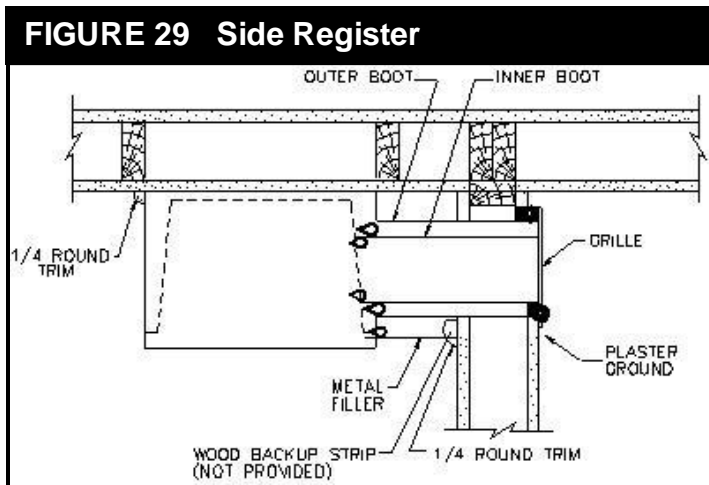

Press Inner Boot against furnace Inner Liner, mark and cut off flush with the wall surface.

Fasten Outer Boot securely to furnace casing with screws provided.

SIDE OUTLET ONLY

Position Inner Boot against furnace Inner Liner and fasten securely through all holes with screws provided.

REAR OUTLET ONLY

Place Inner Boot in position and fasten with screws along the top and bottom edges only. Place Damper Assembly inside Inner Boot and fasten with one (1) screw on each side. Thread chain through key hole in clip on Outer Grille and attach the Bell end.

SIDE AND REAR OUTLETS

Place Outlet Grille into position, drill through the wall material and Plasterground with a #33 drill bit, using the holes in grille as a template and secure with screws provided.

VENT ENCLOSURE KIT INSTALLATION (SURFACE MOUNT ONLY)

Refer to Fig. 30.

Cut Side Panels to fit between the top of furnace casing and ceiling.

Fasten Side Panels to wall parallel to furnace casing sides.

Cut Front Panel height to fit. Note that the bottom edge of Front Panel is notched to fit into the furnace casing recess.

Fasten Front Panel to Side Panels with screws provided.

SIDE CASING GRILLE KIT MODEL 6702

See clearances on Page 23, Fig. 31.

Locate marked opening(s) on outer furnace casing. Mark and cut an opening 1 inch wider than opening already marked (1/2 inch larger on all four sides) as shown on Page 13, Fig. 13.

Remove knockout plate and knockouts for screws from furnace inner liner.

Fasten Boot to Inner Liner with screws provided.

Using holes in grille as a template, drill two (2) #33 holes in outer casing and fasten securely with screws provided.

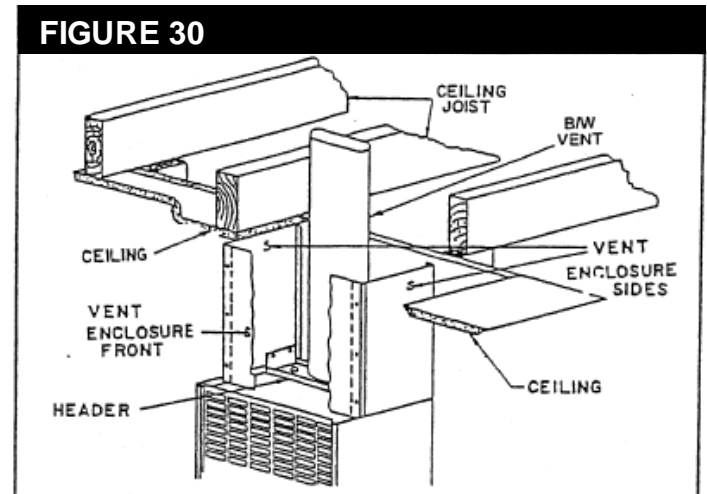

Installing Your Furnace

FIGURE 31 Side Outlet

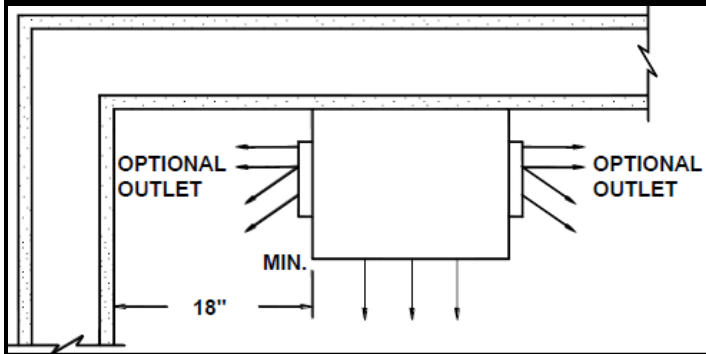

2-WAY FRONT DIFFUSING GRILLE KIT MODEL 6703

Refer to Fig. 32.

CAUTION: For use only in conjunction with a front outlet when the furnace is spaced at least 12 inches from an intersection wall (see Fig. 33).

Metal clips on backside of grille snap into side louvers of front warm air outlet. Adjust clips with pliers if necessary. Grille may also be attached with sheet metal screws.

1-WAY FRONT DIFFUSING GRILLE KIT MODEL 6704

Follow instructions for 2-WAY FRONT DIFFUSING GRILLE 6703 except furnace clearance to an adjacent wall must be 3/4 inch minimum. See Page 8, Fig 3A.

TRIM STRIP KIT MODEL 4701

When desired, optional Trim Strip Kit may be used to cover the crack between furnace and wall. See Figs. 34 and 35. Place strips tight against furnace with other edge against wall surface and fasten to wall with escutcheon pins provided. Cut off trim strips to fit each furnace as required.

NOTE

Quarter-round wood molding may be used for trim if desired, which may be painted to match the wall.

FIGURE 33

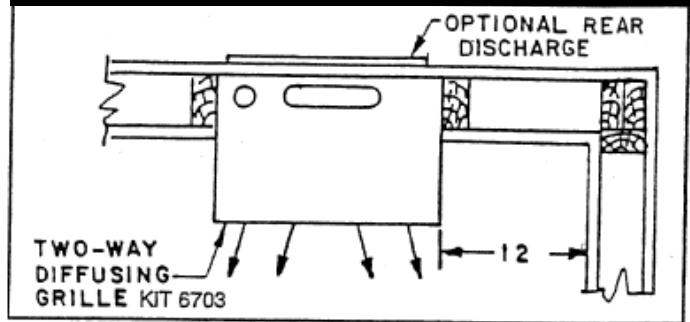

FIGURE 34

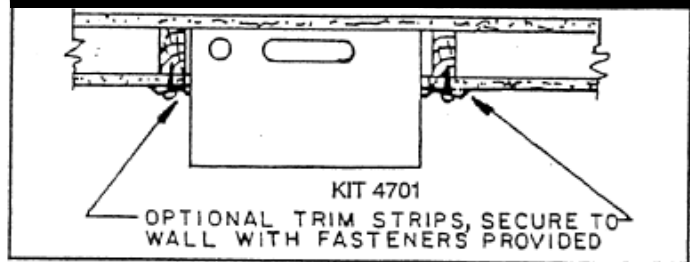
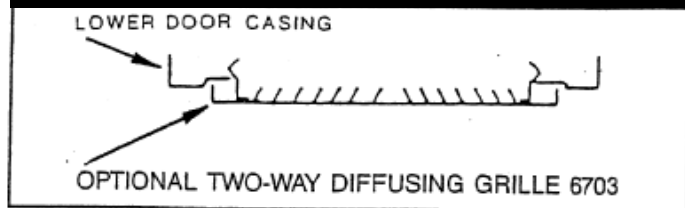

FIGURE 32



Installing Your Furnace

Start-Up Procedure

WARNING: Danger of bodily injury or death. Liquefied petroleum L.P. Gas is heavier than air and it will settle in any low area, including open depressions and it will remain there unless the area is ventilated.

Never attempt start-up of unit before thoroughly ventilating area.

Check the furnace operation as outlined in the following instructions. If any sparking, odors or unusual noises are encountered, shut off electric power immediately. Recheck for wiring errors or obstructions in or near fan motor.

WARNING: Natural gas heating value (Btu per cubic foot) can vary significantly. Therefore, it is the installer's responsibility to see that Btu/hr. input to the furnace is adjusted properly. Failure to do so could cause combustion chamber failure, asphyxiation, fire or explosion resulting in damage, bodily injury or death. Refer to the National Fuel Gas Code (NFPA 54) to be sure the furnace is burning fuel at the proper rate.

Under firing could cause inadequate heat, excessive condensation or ignition problems. Over firing could cause sooting flame impingement or overheating of the heat exchanger.

Before starting natural gas input check, obtain heating value of gas (BTU per cubic foot) at standard conditions from your local supplier. This factor is used in "Check the Gas Input" section and procedure.

CHECK GAS INPUT AND PRESSURES

For furnaces located at elevations between sea level and 2,000 feet, the measured input must not be greater than the input shown on the rating plate of the furnace. For elevations above 2,000 feet, the measured input must not exceed the input on the rating plate reduced by 4 percent for each 1,000 feet that the furnace is above sea level.

Gas supply pressure and manifold pressure with the burners operating must also be as specified on the rating plate.

Rated input will be obtained on a heating value of 2,500 Btu/hr. for

Type of Gas	Manifold Pressure, In. W.C.
Natural	4.0
L.P.	10

propane at 10 inches manifold pressure with factory-sized orifices. If L.P. gas having a different heating value is supplied, orifices must be changed by a qualified service technician before the furnace is operated.

CHECK THE MANIFOLD GAS PRESSURE

A tapped opening is provided in the gas valve to facilitate measuring the manifold gas pressure. A "U Tube" manometer having a scale range from 0 to 12-inches of water should be used for this measurement. The manifold pressure must be measured with the burner and pilot operating. Any major changes in flow must be made by changing the size of the burner orifice.

Check with your local gas supplier for proper orifice sizing.

CHECK THE GAS INPUT (NATURAL GAS ONLY)

To measure the input, using the gas meter, proceed as follows:

1. Turn off gas supply to all other appliances except the furnace.
2. With the furnace operating, time the smallest dial on the meter for one complete revolution. If this is a 2-cubic-foot dial, divide the seconds by 2. If it is a 1-cubic-foot dial, use the time in seconds as is. This gives the seconds per cubic foot of gas being delivered to the furnace.
3. Assuming natural gas with a heating value of 1,000 Btu per cubic foot and 34-seconds per cubic foot used as determined by step (2), then:

Seconds per hour = 3,600

Input = 1,000 x 3,600 / 34 = 106,000 Btu/hr.

This measured input must not be greater than the input indicated on the nameplate of the furnace.

4. Relight all other appliances turned off in Step 1 above. Be sure all pilots are operating.

ADJUST PILOT BURNER (STANDING PILOT MODELS ONLY)

Pilot flame should surround 3/8 inch to 1/2 inch of the thermocouple tip. To adjust, remove pilot adjustment screw on gas valve. Turn screw counterclockwise to increase flame, clockwise to decrease. Replace cap.

CHECK THERMOSTAT

Check thermostat operation. When set above room temperature shown on the thermostat, the main burner should light. Make certain the thermostat turns off the furnace when the room temperature reaches the selected setting and starts the furnace when room temperature falls a few degrees.

FIGURE 35 Thermostat

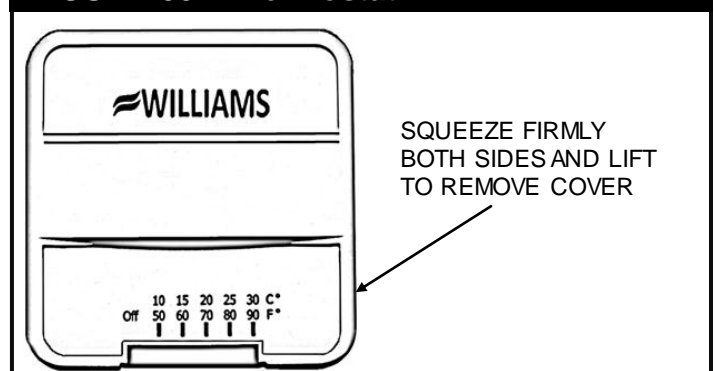

Operating Your Furnace

Operating Your Furnace

STANDING PILOT MODELS

6008531;6008532

NOTE:

For models equipped with WILLIAMS gas valve P323209 or P322042 refer to this page and page 26 for "SAFETY & LIGHTING INSTRUCTION" and "TURN GAS OFF TO APPLIANCE."

On new installations, the gas lines will be filled with air and it may take several minutes to establish the pilot flame.

Keep all access doors and panels in place except for inspection and maintenance.

WARNING: THE SURFACE OF THE FURNACE IS HOT DURING OPERATION. KEEP CHILDREN, CLOTHING, FURNITURE, AND FLAMMABLE MATERIAL AWAY FROM IT
DO NOT STORE OR USE GASOLINE OR OTHER FLAMMABLE LIQUIDS OR VAPORS NEAR THE FURNACE.

SAFETY CONTROLS

These furnace are protected against unsafe operation by five automatic safety controls: (1) A safety pilot acts to shut OFF the gas valve in case of pilot failure; (2) A redundant gas valve; (3) A limit switch shuts down the main burner to prevent overheating the furnace cabinet; (4) A vent safety shutoff device shuts down the main burner to protect against improper venting of combustion products. These limit switches will reset when furnace cools; and (5) A thermal overload protects the motor against burnout caused by current surges or if anything should block the flow of air through the furnace. This switch will reset itself when the motor cools down and it cannot be adjusted.

WARNING: DANGER OF IGNITION FLASH AND EYE INJURY OR BLINDNESS.
PROTECT YOUR EYES. NEVER ATTEMPT TO LIGHT PILOT WITH GAS CONTROL VALVE KNOB IN "ON" POSITION. FLASHBACK COULD OCCUR.

TWO-SPEED FAN OPERATION

For models equipped with WILLIAMS gas valve P323209 or P322042: Blower will first operate at low speed then shift to high speed as the furnace heats up.

IMPORTANT

KEEP BURNER AND CONTROL COMPARTMENT CLEAN.

WARNING: DANGER OF PROPERTY DAMAGE
BODILY INJURY OR DEATH
IF THE FURNACE OVERHEATS OR FAILS TO SHUT OFF, CLOSE MANUAL GAS VALVE FOR THE FURNACE BEFORE TURNING OFF THE ELECTRIC POWER.

Operating Your Furnace

FOR YOUR SAFETY, READ BEFORE LIGHTING

WARNING: If you do not follow these instructions exactly, a fire or explosion may result causing property damage, personal injury or loss of life.

- A. This appliance has a pilot which must be lighted by hand. When lighting the pilot, follow these Instructions exactly.
- B. BEFORE LIGHTING smell around the appliance area for gas. Be sure to smell next to the floor because some gas is heavier than air and will settle on the floor.

WHAT TO DO IF YOU SMELL GAS

- Do not try to light any appliance or strike a match.
- Do not touch any electric switch; do not use any phone in your building.
- Immediately call your gas supplier from a neighbor's phone. Follow the gas supplier's instructions.

- If you cannot reach your gas supplier, call the fire department.
- C. Use only your hand to push in or turn the gas control knob. Never use tools. If the knob will not push in or turn by hand, don't try to repair it, call a qualified service technician. Force or attempted repair may result in a fire or explosion.
 - D. Do not use this appliance if any part has been under water. Immediately call a qualified service technician to inspect the appliance and to replace any part of the control system and any gas control which has been under water.

NOTE: FOR ADDITIONAL INFORMATION REFER TO THE INSTALLATION AND OPERATION INSTRUCTION MANUAL SUPPLIED WITH THIS APPLIANCE OR CONTACT THE MANUFACTURER IDENTIFYING THE PRODUCT BY ITS MODEL NUMBER LOCATED ON THE RATING PLATE, FOUND NEAR THE GAS VALVE.

LIGHTING INSTRUCTIONS

1. STOP! Read the safety information above.
2. Set the thermostat to lowest setting.
3. Turn off all electric power to the appliance.
4. Remove control access panel.
5. Turn gas control knob clockwise  to "OFF".

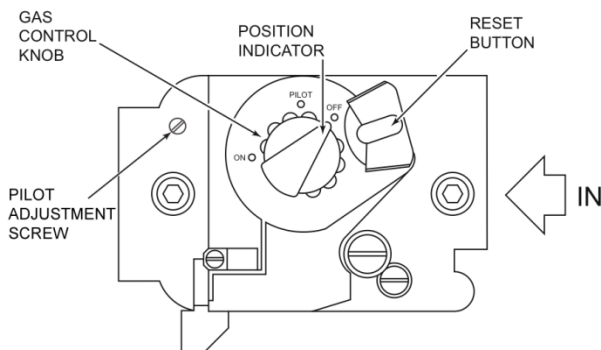

6. Wait five (5) minutes to clear out any gas, then smell for gas, including near the floor. **If you then smell gas, stop!** Follow "B" in the safety information above. If you don't smell gas, go to the next step.
7. Loosen wing nut and open pilot observation door (if equipped).
8. To find pilot, follow the metal tube from gas control. The pilot is mounted on the side of the burner.

9. Turn knob on gas control counterclockwise  to "PILOT."

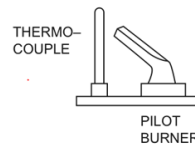

10. Push in the red reset button all the way and hold in. Immediately light the pilot. Continue to hold the red reset button in for about (1) minute after the pilot is lit. Release button and it will pop back up. Pilot should remain lit. If it goes out, repeat steps 5 through 10.
 - If button does not pop up when released, stop and immediately call your service technician or gas supplier.
 - If the pilot will not stay lit after several tries, turn the gas control knob to "OFF" and call your service technician or gas supplier.
11. Close the pilot observation door and tighten wing nut (if equipped).
12. Turn gas control knob counterclockwise  to "ON". The knob can be turned to "ON" only if red reset button is up.
13. Replace the control access panel.
14. Turn on all electric power to the appliance.
15. Set thermostat to the desired setting.

TO TURN OFF GAS TO APPLIANCE

1. Set the thermostat to lowest setting.
2. Turn off all electric power to the appliance if service is to be performed (if applicable).
3. Remove the control access panel.
4. Push in the gas control knob slightly and turn it clockwise to "OFF". Do not Force.
5. Replace the control access panel.

IMPORTANT: KEEP BURNER AND CONTROL COMPARTMENT CLEAN.

WARNING: DUE TO HIGH SURFACE TEMPERATURES - KEEP CHILDREN, CLOTHING, FURNITURE OR ANY COMBUSTIBLE MATERIAL AWAY FROM FURNACE.

Caring for Your Furnace

How To Care For Your Furnace

WARNING: Danger of bodily injury or death. Turn off electric power supply at the disconnect switch, fuse box or service panel before removing any doors or access or service panels from the unit.

CABINET FINISH

Clean the cabinet with damp rag. Never use abrasive cleaners. Cabinets are finished in heat resistant powder coated finish - DO NOT refinish with wall paint.

COMBUSTION AND VENTILATION AIR

The combustion and ventilation air supply must not be blocked.

Do not put anything in or on the furnace cabinet.

For better circulation and more effective heating, do not place obstructive furniture closer than four feet to the front of the cabinet or two feet to either side of the cabinet.

FURNACE AREA

Keep the area near the furnace clear and free from combustible materials, gasoline, and other flammable liquids and vapors.

ANNUAL UPKEEP NEEDED

It is recommended that a qualified service technician perform these checks at the beginning of each heating season.

CLEANING AND OILING

Shut off electricity, and then remove cabinet door and front panel. Clean any lint or dirt from fan blades, fan motor, and exposed air passages. Use a brush.

Put 5 drops of SAE 20 oil in each of the two cups or oil tubes on the fan motor, See Fig. 36, below.

FIGURE 36 Motor Oil Holes

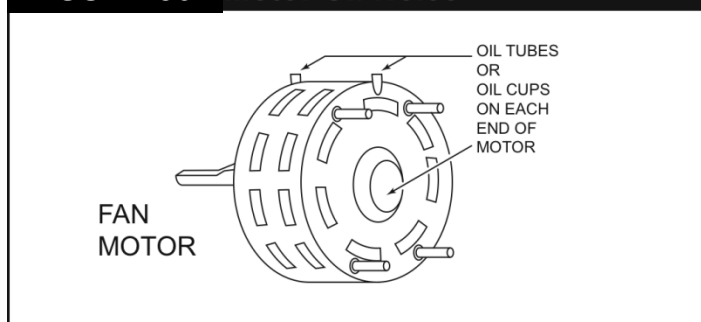

PILOT BURNER

Light pilot using instructions in OPERATING YOUR FURNACE (on pages 25 and 26, depending on your model). Leave thermostat at lowest setting.

Pilot flame should surround 3/8 to 1/2 inch of the thermocouple tip. Refer to Fig. 38, Page 28. If flame needs adjusting, do it as follows:

ADJUST PILOT BURNER (Page 28, Fig 38)

1. Insert small screwdriver, adjust flame as needed. Turn screw counterclockwise to increase flame, clockwise to decrease.
2. Turn thermostat to highest setting. Main burners should light quickly and smoothly. Turn thermostat to lowest setting. Main burners should go out. Pilot should remain lit except for electronic ignition models. See Page 26.

BURNER FLAME

Start the furnace and let it operate about 10 minutes then look at the burner flame. Flames should be soft and blue, see Fig. 37. If flames appear abnormal, contact the gas company or a qualified service technician immediately.

VENTING SYSTEM

Make sure that no parts of the vent air system are blocked or rusted. Clean or replace before using furnace.

FIGURE 37 Main Burner Flame Pattern

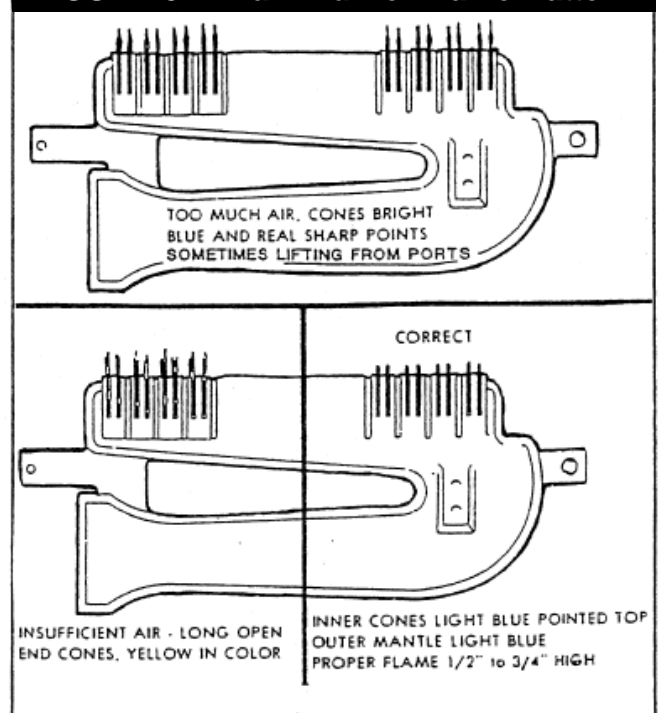

Caring for Your Furnace

How To Care For Your Furnace

BURNER CLEANING

Check burner. If cleaning is required, contact a qualified service technician to clean and service burner.

WARNING: Danger of bodily injury or death. Make sure electric power and gas supply are off before removing panels or doors, etc.

CLEANING BURNER COMPARTMENT

Because cold air is attracted to the flame during furnace operation, a build up of lint from bedding and dust, etc., in the burner area will occur each heating season. It is necessary to clean this area regularly. Use a vacuum cleaner with a narrow attachment to reach small areas. Be careful in and around the pilot. A change in its adjustment could be made if struck during cleaning.

WARNING: A BUILDUP OF ANY DUST, LINT OR FOREIGN MATERIAL IN THE PRIMARY AIR OPENING OF THE BURNER CAN INTERFERE WITH THE PROPER AIR GAS MIXTURE AND CAN RESULT IN A YELLOW FLAME WHICH CAN PRODUCE CARBON MONOXIDE AND SOOT. THIS CONDITION, IF ALLOWED TO DEVELOP, CAN LEAD TO BODILY INJURY INCLUDING DEATH. IT IS IMPERATIVE THAT THE BURNER(S) BE KEPT CLEAN.

TO REMOVE BURNER(S)

Disconnect gas line inside cabinet.

Refer to "Mounting Your Furnace" section (pages 16 and 17).

MODELS: 6008531, 6008532

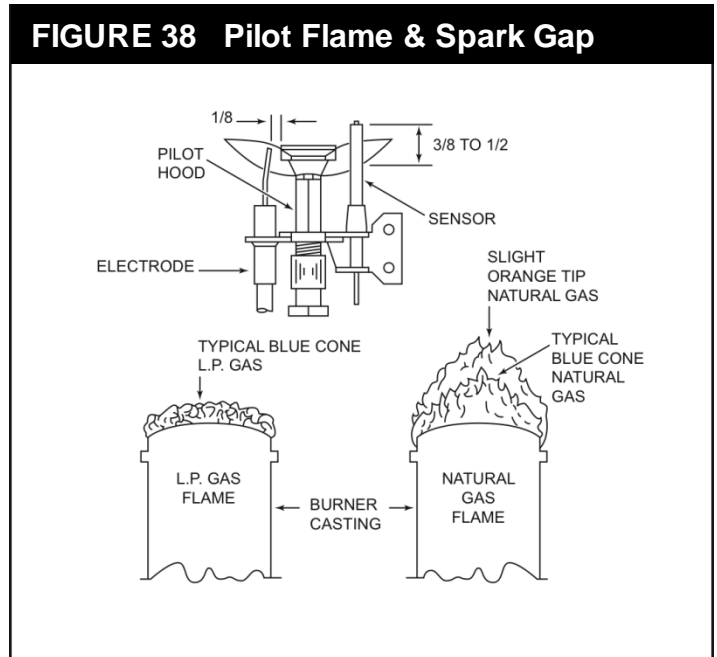

Check the spark gap. It must be carefully adjusted to specifications, as illustrated (Fig. 38), for the ignition device to function properly.

Furnace Technical information

Furnace Technical Information							
Model Number	Gas Type	Input** Rating Btu/hr.	Output Capacity*	Main Burner Orifice		Pilot Orifice	
				DRILL	QTY.	DRILL	DEC.
6008532	NATURAL	60,000	48,600	#39	2	#81	.0130
6008531	L.P.	60,000	49,600	#53	2	#92	.0080

*The output capacity of these appliances is a product of thermal efficiency rating determined under continuous operating conditions and was determined independently of any installed System.

**For elevations above 2000 feet reduce ratings 4% for each 1000 feet above sea level.

**Btu/hr. = British Thermal Units per hour

Troubleshooting

FOR MODELS: 6008532;6008531

SYMPTOM	POSSIBLE CAUSE	CORRECTIVE ACTION
1. Pilot will not stay lit after following lighting instructions.	A. Thermocouple producing insufficient millivolts.	Check pilot flame – it must impinge on thermocouple. Pilot flame may be low or blowing (high) causing safety to drop out. Pilot orifice or aerating hole may be plugged (check for spiders, webs or other organic material). Be sure the thermocouple is fully inserted in its bracket.
	B. Loose or dirty thermocouple connection at gas valve.	Clean and/or tighten the thermocouple fitting at the connection to the valve.
	C. Thermocouple defective.	Check thermocouple with millivolt meter – it should generate approximately 30 millivolts when not connected to a load. When connected to a load, it should generate approximately 14 millivolts. If below 7 millivolts, replace.
	D. Thermomagnet pilot safety defective	Replace gas valve after above is checked out.
	E. Vent safety shutoff device.	Check wiring connections from valve to the vent safety shutoff device. Be sure all connections are tight. Check for blocked or incorrect venting.
2. Main burner will not come ON - pilot burning and thermostat set for heat.	A. Gas valve not turned ON after lighting the pilot.	Turn gas valve knob to "ON" position - if no main gas flow, proceed to Step "B".
	B. Electric power to furnace turned OFF.	Check for line voltage at furnace - if okay and no main gas flow, proceed to Step "C".
	C. Low voltage transformer or limit switch defective.	Check for 24 volts at the low voltage terminals of the transformer. If no voltage, turn OFF electric power to furnace. Remove one wire from limit switch and check for continuity across both terminals. No continuity – replace limit switch. With a good limit switch back in the circuit and the electric power turned ON - if no voltage, replace transformer. NOTE: Before replacing the transformer or limit switch, check wiring for loose connections or broken wires and repair as needed. If voltage is present at transformer, proceed to Step "D".
	D. Wall thermostat defective.	With thermostat set for heat (contacts closed) check for voltage at terminals on gas valve. If no voltage is present replace defective thermostat. NOTE: Before replacing thermostat, be sure to check the wiring from the furnace to thermostat for loose connections or broken wires and replace as needed.
	E. Burner orifice plugged.	Clean or replace orifice - if okay and still no gas flow to main burners, proceed to Step "F".
	F. Gas valve defective.	Replace defective gas valve.
3. Burner comes "ON" but goes OFF before blower turns ON.	A. Defective wiring.	Turn OFF electric power to furnace. Remove top front panel, fan shroud and blower wheel. Refer to Wiring Diagram and check all wiring inside junction box. Remove center front panel and check all wiring inside switch box containing fan, limit and selector switches. Correct if necessary. If correct, proceed to Step "B".
	B. Defective limit switch.	If burner goes OFF in less than five minutes from room temperature start, check limit control switch. If defective, replace. NOTE: Blower should turn "ON" within three minutes after burner is "ON" from a room temperature start. If not, proceed to Step "C".
	C. Defective motor (2-speed).	Jumper across the fan switch, turn electric power ON, the motor should rotate. If a 2-speed motor is used - jumper from "brown" terminal on the fan switch to #2 (red) terminal on the selector switch, motor should rotate on "LOW" speed. Jumper from same "brown" terminal on the fan switch to #3 (black) terminal on the selector switch, motor should rotate on "HIGH" speed. Replace motor if defective.
	D. Defective motor (1-speed).	Jumper across fan switch, turn electric power ON, motor should rotate. Replace motor if defective.
	E. Defective fan switch.	If, after checking above possibilities, problem still exists, replace fan switch.
4. Burner comes "ON", blower comes "ON", but cycles "ON" and "OFF" while burner remains "ON".	A. Furnace not operating at full rate.	Check for low gas pressure at gas valve - should be 4" W.C. for Natural Gas, 11" W.C. for L.P. Gas. Check burner orifice.
5. Burner comes "ON", blower comes "ON", but burner cycles "OFF" and "ON" with blower "ON".	A. Furnace operating over-rate.	Check for high gas pressure at gas valve - correct if necessary. See correct pressure above.
	B. Line voltage too low.	Check line voltage to motor, if below 115 volts motor will run too slow.
	C. Recirculation.	Heated air discharging against an object causing recirculation, such as a hall installation or a large piece of furniture within 4' of discharge.
	D. Loss of circulating air due to leakage.	Check header plate installation and proper use of gaskets. Repair as necessary.
6. Furnace operates but turns "OFF" before room temperature is attained.	A. Thermostat location.	Check location of thermostat. It should not be in the path of warm air discharge from the furnace, near a lamp, or above a TV set or stereo.
	B. Defective thermostat.	Check thermostat calibration or replace.

Troubleshooting

SYMPTOM	POSSIBLE CAUSE	CORRECTIVE ACTION
7. Furnace operates but will not shut "OFF" when room temperature is attained.	A. Thermostat wiring defective.	Check thermostat wiring from furnace to thermostat - may be shorted together by a nail or staple.
	B. Thermostat location.	Check thermostat location - if on an outside wall or there is a hole in wall behind the thermostat causing cold air to contact thermostat, relocate the thermostat.
8. Abnormal operation.	A. Blower noise.	Check motor mounts - they may be loose. Blower wheel could be out of balance. Set screw may be loose on motor shaft. Blower may be rubbing on fan shroud. Motor may need oiling. Correct as needed.
	B. Expansion noise ticking.	Check installation - casing may be twisted or not level at time of installation causing combustion chamber to bind on its locating pins.
	C. Burner resonance.	Usually associated with L.P. Gas operation. Adjust primary air screw in throat of each cast iron burner after about 10 minutes of operation. Adjust to obtain a soft blue flame without streaming yellow tips.
	D. Selector switch defective.	During normal furnace operation the motor will be on "LOW" speed when operating on minimum input capacity and on "HIGH" speed when operating at maximum input capacity. If there is no change in motor speed, replace selector switch.

Wiring Diagrams

MODELS - 6008531; 6008532

FOR 50M, 60M, 65M B.T.U. FAN TYPE VENTED WALL FURNACE WITH STANDING PILOT CONTROL SYSTEM

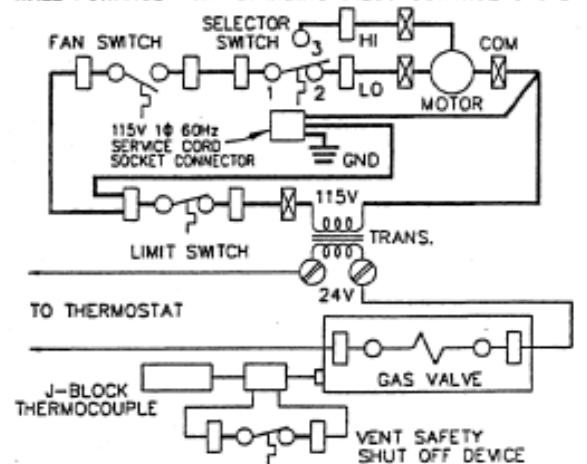

- LEGEND**
- FACTORY WIRED LINE VOLTAGE.
 - FACTORY WIRED LOW VOLTAGE.
 - 1/4 QUICK CONNECT TERMINAL FOR FACTORY WIRING.
 - ⊗ WIRE CONNECTOR FOR FACTORY WIRING LINE VOLTAGE.
 - ⊙ SCREW TERMINAL LOW VOLTAGE.
 - FACTORY WIRED CONNECTION
- NOTES:**
1. IF ANY OF THE ORIGINAL WIRE AS SUPPLIED WITH THE APPLIANCE MUST BE REPLACED, IT MUST BE REPLACED WITH TYPE AWM 105°C, 18 GA. WIRE 4/64 INSULATION OR EQUIVALENT.
 2. MOTOR IS THERMALLY OVERLOAD PROTECTED.
- 115V, 1Ø 60Hz.—LESS THAN 3 AMPS.

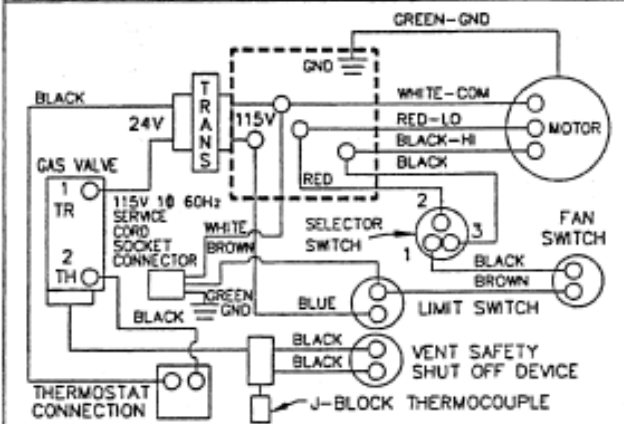

Replacements Parts

REPLACEMENT PARTS FOR MODELS 6008531, 6008532

CONTROL ASSEMBLY MODELS: 6008531; 6008532

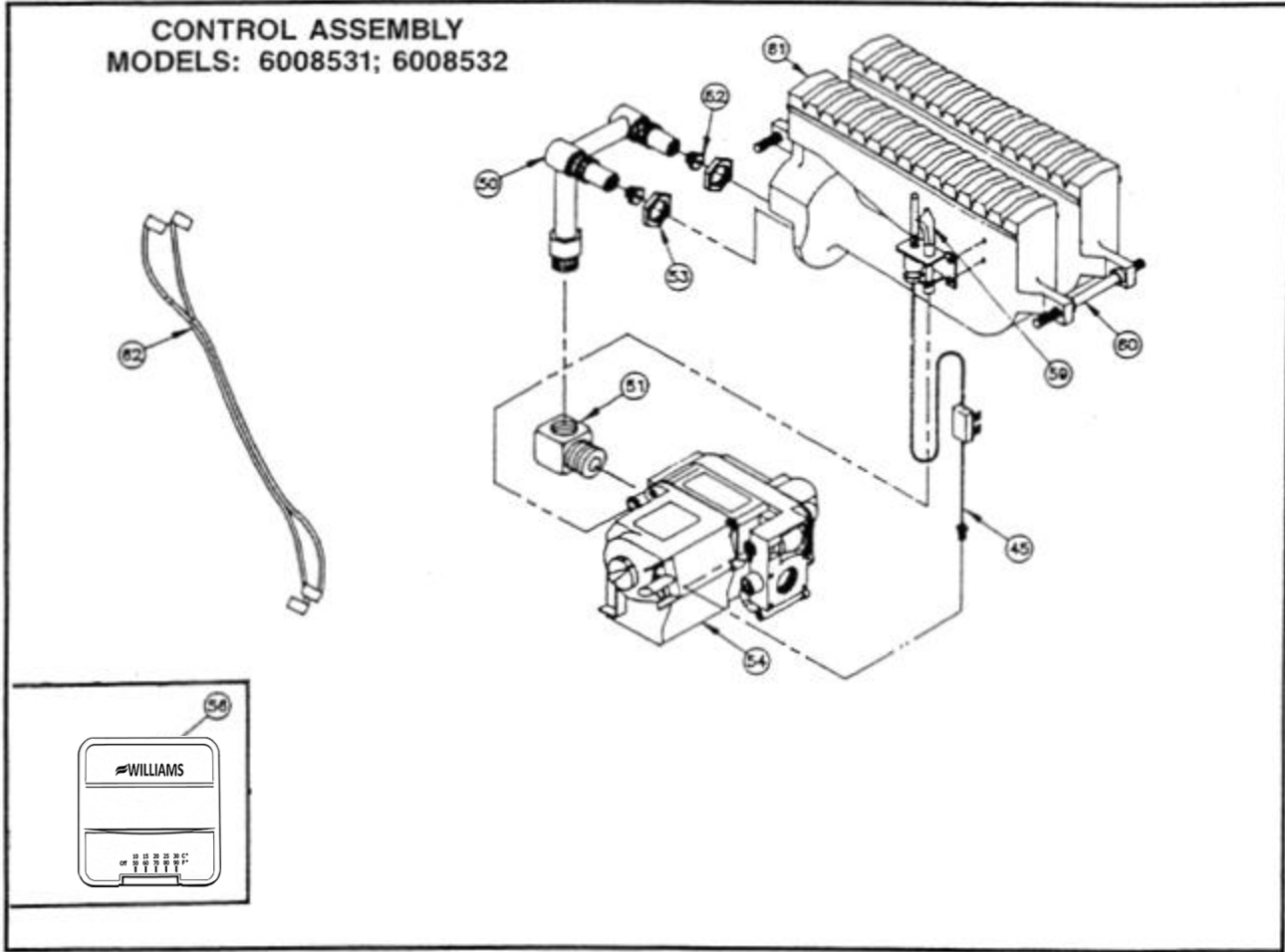

Replacements Parts List

REPLACEMENT PARTS FOR MODELS 6008531;6008532

Ref. Number	Description	PART NO. FOR MODEL	
		6008532	6008531
1	Outer Casing (Less Front Panel)	7D18	7D18
2	Inner Liner	7B138	7B138
3	Lower Front Angle	7A218	7A218
4	Burner Shield	7B149	7B149
5	Second Chamber	7C86	7C86
6	Gasket, Chamber Union	P321919	P321919
7	Combustion Chamber	7B169	7B169
8	Gasket, Element Face	P321911	P321911
9	Element Faceplate	7A220	7A220
10	Gasket, Element Base	P321912	P321912
11	Switch Box	7B183	7B183
12	Limit Switch	P200300	P200300
13	Selector Switch	P296201	P296201
14	Fan Switch	P200200	P200200
15	Cover, Switch Box	11C68	11C68
16	Handle Deflector Baffle	11C63	11C63
17	Center Front Panel	7B136	7B136
18	Bottom Front Panel	7B171	7B171
19	Top Front Panel	7B147	7B147
20	Fan Shroud	7B170	7B170
21	Fan Blade	P200600	P200600
22	Motor	P321601	P321601
23	Motor Support	7B46	7B46
24	Vibration Isolator (4 required)	P022800	P022800
25	Drafhod Faceplate	7C85	7C85
26	Vent Safety Switch	P321958	P321958
27	Drafhod	7B165	7B165
28	Gasket, Drafhod Front	P322003	P322003
29	Gasket, Drafhod Rear	P322004	P322004
30	Heat Deflector	7C99	7C99
31	Internal Wires	For reference only	
32	Transformer	P024200	P024200
33	Cover, Junction Box	7B155	7B155
34	Vent Cover	7B12	7B12
35	N/A	-	-
36	Header	7B57	7B57
37	Flue Collar Gasket	P027100	P027100
38	Diffusing Grille Kit. Two-Way	6703	6703
38	Diffusing Grille Kit. One-Way	6704	6704
39	* Damper		
40	* Rear Inner Boot 10-3/4" Long		
41	* Rear Outer Boot 10" Long	6801	6801
42	* Plaster Ground		
43	* Rear Grille Two-Way		
44	* Side Inner Boot 10-3/4" Long		
45	* Side Outer Boot 10" Long		
46	* Side Plaster Ground	6701	6701
47	* Side Grille		
44	* Side Inner Boot 1" Long		
47	* Side Grille	6702	6702
48	Hinge Wire Extension (2 Required)	7A225	7A225
49	Support, Second Chamber	7A219	7A219
50	Manifold	P323658	P323658
51	Manifold Adaptor	P321888	P321888

Replacements Parts List

52	Orifice Fitting, Specify Gas Type & Input	P090539	P090553
53	Locknut, Special (2 Required)	P026200	P026200
54	Gas Control Valve	P323209	P322042
55	N/A	-	-
56	Thermostat	P322016	P322016
57	Thermocouple	P321838	P321838
58	Flame Sensor	-	-
59	Pilot	P179700	P179800
60	Burner, Spacer (2 Required)	P018100	P018100
61	Burner, Cast Iron	P025600	P025600
62	Wire Assembly, Vent Safety	P322048/ P322048A	P322048/ P322048A
63	* Ignition Control Wires	-	-
64	* Owner's Manual	P321909	P321909
65	* Burner Shield	7B173	7B173

* Not shown

For part illustration, see pages 31 and 32.

Note: Screws and bolts are standard hardware items, available locally.

Forsaire Hardwire Accessory - 9940

Installation Instructions

This Kit is for use with Models: 3508331; 3508332; 3508731; 3508732; 4007331; 4007332; 4007731; 4007732; 5008731; 5008732; 5507331; 5507332; 5508331; 5508332; 6008531; 6008532; 6257731; 6257732; 6508731; 6508732

WARNING: Danger of bodily injury. Turn off electric power supply at disconnect switch, fuse box or service panel before working on the furnace.

SUMMARY: This accessory converts Williams' Forsaire Counterflow furnaces using the electric service cord provided, to a hardwired, permanent electrical connection.

If this furnace is equipped or has been previously installed and operated using the service power cord, disconnect the cord at the receptacle connector located at the base of the furnace and remove the cord completely from the furnace.

Following the wiring diagram below, make all the necessary wiring connections from an outside electrical source. All electrical work must conform to your local codes and ordinances or in their absence, with National Electrical Code, ANSI/NFPA 70 or in Canada, Canadian Electrical Code C22.1. If you are not familiar with wiring codes in general, have a competent electrician do this job. Be sure this accessory is of the type and design required for use with your furnace.

The 40077 model series with a single speed motor is shown in the wiring diagram below. The required field wiring connections are applicable to all models listed above. For internal wiring connections to your model, refer to the wiring diagram attached to the furnace.

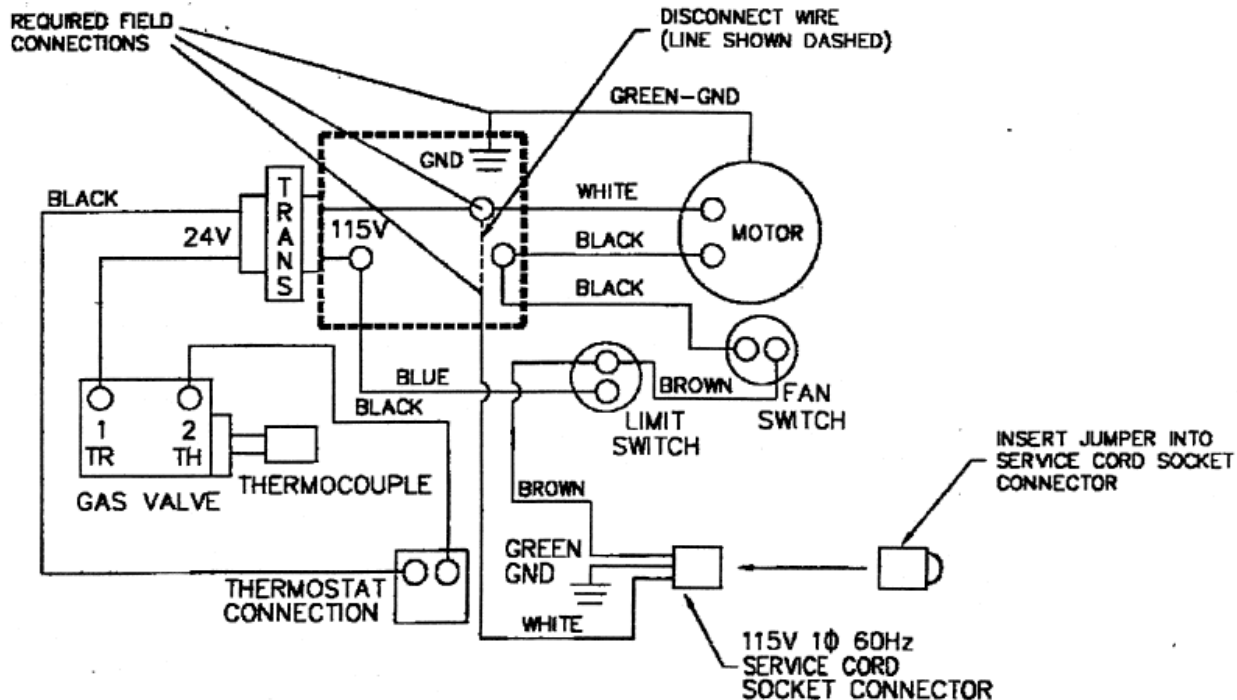

Hints and Information

Service Hints

If your furnace fails to work correctly, you may avoid the inconvenience and cost of a service call by checking the troubleshooting section on pages 29 and 30 before you call for service.

WARNING: If the information in this manual is not followed exactly, a fire or explosion may result causing property damage, personal injury or loss of life.

DO NOT store or use gasoline or other flammable vapors and liquids in the vicinity of this or any other appliance.

WHAT TO DO IF YOU SMELL GAS

- Open all of the windows.
- Do not try to light any appliance.
- Do not touch any electrical switch.
- Do not use any phone or cell phone in your building.
- Extinguish any open flame.
- Immediately call your gas supplier from a neighbor's phone. If you cannot reach your gas supplier, call the fire department.

Installation and service must be performed by a qualified installer, service agency or the gas supplier.

How to Order Repair Parts

When ordering repair parts, always give the following information:

1. MODEL NUMBER
2. MFG. DATE CODE
3. PART NUMBER
4. PART DESCRIPTION

All parts listed herein may be ordered from your equipment supplier. The Model Number of your Williams wall furnace will be found on the nameplate near gas valve, inside control compartment.



Williams Furnace Company • 250 West Laurel Street, Colton, CA 92324
(909) 825-0993 • FAX: (909) 824-8009 • www.wfc-fc.com

Manufactured in the U.S.A. • Established 1916



P321909 - October 2012
ALL RIGHTS RESERVED