



MOTOROLA

MTX8250 and MTX9250

Portable Radio for Privacy Plus™ Systems
Radio Portatif pour Systèmes Privacy Plus™

reliable



flexible



powerful

User Guide
Guide de l'utilisateur



As Dedicated As You Are™

Professional Radio

CONTENTS

Computer Software Copyrights	3	Mode Selector Knob	16
Safety	5	Push-to-Talk (PTT) Button	16
Safety and General Information	5	LED Indicator	16
Radio Frequency (RF) Operational		Microphone	16
Characteristics	5	Keypad Keys	17
Portable Radio Operation and		Menu Keys	18
EME Exposure	5	Selecting a Feature	18
Two-way Radio Operation	6	Menu Display	19
Body-worn Operation	6	LCD Screen	19
Antenna Care	6	Alert Tone Indications	21
Approved Accessories	7	Programmable Buttons	23
Electromagnetic Interference/Compatibility .	7	Trunked Radio Systems	25
Facilities	7	Getting Started	27
Aircraft	7	Battery Information	27
Safety and General	8	Charging the Battery	27
Operational Warnings	8	Attaching the Battery	29
Operational Cautions	9	Removing the Battery	29
Intrinsically Safe Radio Information	10	Accessory Information	30
FMRC Approved Equipment	10	Removing the Antenna	30
Repair of FMRC Approved Products	11	Attaching the Belt Clip	31
Radio Overview	15	Removing the Belt Clip	31
Parts of the Radio	15	Attaching the Side Connector Cover	32
MTX8250 and MTX9250 Models	15	Turning Radio On or Off	32
On/Off/Volume Knob	16	Adjusting the Volume	33
		Selecting a Trunked or Conventional Zone	33
		Selecting a Zone	33

Selecting a Mode (Either a Trunked Talkgroup or a Conventional Channel) . . .	34
Sending a Trunked Call	34
Sending a Conventional Call	35
Receiving a Trunked or Conventional Call. . .	35
Failsoft Operation (Trunked Systems Only) . .	35
Coded Squelch Operation (Conventional Channels Only)	36
Repeater or Talkaround Mode (Conventional Operation Only)	36
Variable RF Power Level	37
Smart PTT (Conventional Operation Only) . .	37
Muting the Keypad Tones.	38
Radio Calls (Trunked Operation Only)	39
Viewing Your Radio's ID Number	39
Enhanced Private Call Operation	39
Receiving a Private Conversation Call . . .	40
Sending a Private Conversation Call . . .	41
Call Alert Operation	43
Sending a Call Alert.	44
Programming the Radio's Call Lists	47
Programming the Telephone List Numbers	47
Programming the Call List.	48
Trunked Telephone Operation	50
Sending a Telephone Call	50
Scan.	55
Scan Operation	55
Turning Scan On or Off with the Keypad . .	55
Deleting Nuisance Modes.	56
Viewing a Scan List.	56
Programming a Scan List	57
Warranty	59
Limited Warranty	59
Accessories	63
Carry Cases	63
Headsets	63
Remote Speaker Microphones.	63
Earpieces	64
Batteries	64
Chargers	64
Antennas	64

COMPUTER SOFTWARE COPYRIGHTS

The Motorola products described in this manual may include copyrighted Motorola computer programs stored in semiconductor memories or other media. Laws in the United States and other countries preserve for Motorola certain exclusive rights for copyrighted computer programs, including, but not limited to, the exclusive right to copy or reproduce in any form the copyrighted computer program. Accordingly, any copyrighted Motorola computer programs contained in the Motorola products described in this manual may not be copied, reproduced, modified, reverse-engineered, or distributed in any manner without the express written permission of Motorola. Furthermore, the purchase of Motorola products shall not be deemed to grant either directly or by implication, estoppel, or otherwise, any license under the copyrights, patents or patent applications of Motorola, except for the normal non-exclusive license to use that arises by operation of law in the sale of a product.

Notes

SAFETY

SAFETY AND GENERAL INFORMATION

IMPORTANT INFORMATION ON SAFE AND EFFICIENT OPERATION

READ THIS INFORMATION BEFORE USING YOUR MOTOROLA TWO-WAY RADIO

The information provided in this document supersedes the general safety information contained in user guides published prior to October 2000. For information regarding radio use in a hazardous atmosphere refer to the Factory Mutual (FM) manual supplement included with radio models that offer this capability and/or the intrinsic safety radio information section of this user manual.

RADIO FREQUENCY (RF) OPERATIONAL CHARACTERISTICS

To transmit (talk) you must push the Push-To-Talk button; to receive (listen) you must release the Push-To-Talk button. When the radio is transmitting, it generates radio

frequency (RF) energy; when it is receiving, or when it is off, it does not generate RF energy.

PORTABLE RADIO OPERATION AND EME EXPOSURE

Your Motorola radio is designed to comply with the following national and international standards and guidelines regarding exposure of human beings to radio frequency electromagnetic energy (EME):

- United States Federal Communications Commission, Code of Federal Regulations; 47 CFR part 2 sub-part J
- American National Standards Institute (ANSI) / Institute of Electrical and Electronic Engineers (IEEE) C95. 1-1992
- Institute of Electrical and Electronic Engineers (IEEE) C95.1-1999 Edition
- National Council on Radiation Protection and Measurements (NCRP) of the United States, Report 86, 1986
- International Commission on Non-Ionizing Radiation Protection (ICNIRP) 1998

- Ministry of Health (Canada) Safety Code 6. Limits of Human Exposure to Radio Frequency Electromagnetic Fields in the Frequency Range from 3 kHz to 300 GHz, 1999
- Australian Communications Authority Radiocommunications (Electromagnetic Radiation - Human Exposure) Standard 1999 (applicable to wireless phones only)

To assure optimal radio performance and make sure human exposure to radio frequency electromagnetic energy is within the guidelines set forth in the above standards, always adhere to the following procedures:

Two-way Radio Operation

When using your radio, **hold the radio in a vertical position with the microphone one to two inches (2.5 to 5 centimeters) away from the lips.**



Body-worn Operation

To maintain compliance with FCC RF exposure guidelines, if you wear a radio on your body when transmitting, always place the radio in a **Motorola approved clip, holder, holster, case, or body harness for this product.** Use of non-Motorola-approved accessories may exceed FCC RF exposure guidelines. **If you do not use a Motorola approved body-worn accessory and are not using the radio in the intended use positions along side of the head in the phone mode or in front of the face in the two-way radio mode, then ensure the antenna and radio is kept the following minimum distances from the body when transmitting:**

- Phone or Two-way radio mode: one inch (2.5 centimeters)
- Data operation using any data feature with or without an accessory cable: one inch (2.5 centimeters)

Antenna Care

Use only the supplied or an approved replacement antenna. Unauthorized antennas, modifications, or attachments could

damage the radio and may violate FCC regulations.

DO NOT hold the antenna when the radio is “IN USE”. Holding the antenna affects call quality and may cause the radio to operate at a higher power level than needed.

Approved Accessories

For a list of approved Motorola accessories look in the appendix or accessory section of your radio’s User Guide.

ELECTROMAGNETIC INTERFERENCE/COMPATIBILITY

Note: Nearly every electronic device is susceptible to electromagnetic interference (EMI) if inadequately shielded, designed or otherwise configured for electromagnetic compatibility.

Facilities

To avoid electromagnetic interference and/or compatibility conflicts, turn off your radio in any facility where posted notices instruct you to do so. Hospitals or health care facilities may be

using equipment that is sensitive to external RF energy.

Aircraft

When instructed to do so, turn off your radio when on board an aircraft. Any use of a radio must be in accordance with applicable regulations per airline crew instructions.

Medical Devices

- **Pacemakers**

The Health Industry Manufacturers Association recommends that a minimum separation of 6 inches (15 centimeters) be maintained between a handheld wireless radio and a pacemaker. These recommendations are consistent with those of the U.S. Food and Drug Administration.

Persons with pacemakers should:

- ALWAYS keep the radio more than 6 inches (15 centimeters) from their pacemaker when the radio is turned ON.
- not carry the radio in the breast pocket.

- use the ear opposite the pacemaker to minimize the potential for interference.
- turn the radio OFF immediately if you have any reason to suspect that interference is taking place.

- **Hearing Aids**

Some digital wireless radios may interfere with some hearing aids. In the event of such interference, you may want to consult your hearing aid manufacturer to discuss alternatives.

- **Other Medical Devices**

If you use any other personal medical device, consult the manufacturer of your device to determine if it is adequately shielded from RF energy. Your physician may be able to assist you in obtaining this information.

SAFETY AND GENERAL

Use While Driving

Check the laws and regulations on the use of radios in the area where you drive. Always obey them.

When using your radio while driving, please:

- Give full attention to driving and to the road.
- Use hands-free operation, if available.
- Pull off the road and park before making or answering a call if driving conditions so require.

OPERATIONAL WARNINGS

FOR VEHICLES WITH AN AIR BAG

Do not place a portable radio in the area over an air bag or in the air bag deployment area. Air bags inflate with great force. If a portable radio is placed in the air bag deployment area and the air bag inflates, the radio may be propelled with great force and cause serious injury to occupants of the vehicle.



WARNING

POTENTIALLY EXPLOSIVE ATMOSPHERES

Turn off your radio prior to entering any area with a potentially explosive atmosphere, unless it is a radio type especially qualified for use in such areas as "Intrinsically Safe" (for example, Factory Mutual, CSA, UL, or CENELEC). Do

not remove, install, or charge batteries in such areas. Sparks in a potentially explosive atmosphere can cause an explosion or fire resulting in bodily injury or even death.

Note: The areas with potentially explosive atmospheres referred to above include fueling areas such as below decks on boats, fuel or chemical transfer or storage facilities, areas where the air contains chemicals or particles, such as grain, dust or metal powders, and any other area where you would normally be advised to turn off your vehicle engine. Areas with potentially explosive atmospheres are often but not always posted.

BLASTING CAPS AND AREAS

To avoid possible interference with blasting operations, turn off your radio when you are near electrical blasting caps, in a blasting area, or in areas posted: "Turn off two-way radio." Obey all signs and instructions.

OPERATIONAL CAUTIONS

ANTENNAS

Do not use any portable radio that has a damaged antenna. If a damaged antenna comes into contact with your skin, a minor burn can result.



Caution

BATTERIES

All batteries can cause property damage and/or bodily injury such as burns if a conductive material such as jewelry, keys, or beaded chains touch exposed terminals. The conductive material may complete an electrical circuit (short circuit) and become quite hot. Exercise care in handling any charged battery, particularly when placing it inside a pocket, purse, or other container with metal objects.

INTRINSICALLY SAFE RADIO INFORMATION

FMRC Approved Equipment

Anyone intending to use a radio in a location where hazardous concentrations of flammable material exist (hazardous atmosphere) is advised to become familiar with the subject of intrinsic safety and with the National Electric Code NFPA 70 (National Fire Protection Association) Article 500 (hazardous [classified] locations).

An Approval Guide, issued by Factory Mutual Research Corporation (FMRC), lists manufacturers and the products approved by FMRC for use in such locations. FMRC has also issued a voluntary approval standard for repair service ("Class Number 3605").

FMRC Approval labels are attached to the radio to identify the unit as being FM Approved for specified hazardous atmospheres. This label specifies the hazardous Class/Division/Group along with the part number of the battery that must be used. Depending on the design of the portable unit, this FM label can be found on the back or the bottom of the radio

housing. The FM Approval mark is shown below:



WARNINGS

- Do not operate radio communications equipment in a hazardous atmosphere unless it is a type especially qualified for such use (e.g., FMRC Approved). An explosion or fire may result.
- Do not operate an FMRC Approved Product in a hazardous atmosphere if it has been physically damaged (e.g., cracked housing). An explosion or fire may result.
- Do not replace or charge batteries in a hazardous atmosphere. Contact sparking may occur while installing or removing batteries and cause an explosion or fire.



WARNINGS

- Do not replace or change accessories in a hazardous



atmosphere. Contact sparking may occur while installing or removing accessories and cause an explosion or fire.

- Do not operate an FMRC Approved Product unit in a hazardous location with the accessory contacts exposed. Keep the connector cover in place when accessories are not used.
- Turn a radio off before removing or installing a battery or accessory.
- Do not disassemble an FMRC Approved Product unit in any way that exposes the internal electrical circuits of the unit.
- Radios must ship from the Motorola manufacturing facility with the hazardous atmosphere capability and FM Approval labeling. Radios will not be “upgraded” to this capability and labeled in the field.
- A modification changes the unit’s hardware from its original design configuration. Modifications can only be made by the original product manufacturer at one of its FMRC-audited manufacturing facilities.

WARNINGS



WARNING

- Failure to use an FMRC Approved Product unit with an FMRC Approved battery or FMRC Approved accessories specifically approved for that product may result in the dangerously unsafe condition of an unapproved radio combination being used in a hazardous location.
- Unauthorized or incorrect modification of an FMRC Approved Product unit will negate the Approval rating of the product.

Repair of FMRC Approved Products

REPAIRS FOR MOTOROLA PRODUCTS WITH FMRC APPROVAL ARE THE RESPONSIBILITY OF THE USER.

You should not repair or relabel any Motorola-manufactured communication equipment bearing the FMRC Approval label (“FMRC Approved Product”) unless you are familiar with the current FMRC Approval standard for repairs and service (“Class Number 3605”). You may want to consider using a repair facility that operates under 3605 repair service approval.

WARNINGS

- Incorrect repair or relabeling of any FMRC Approved Product unit could adversely affect the Approval rating of the unit.
- Use of a radio that is not intrinsically safe in a hazardous atmosphere could result in serious injury or death.



FMRC's Approval Standard Class Number 3605 is subject to change at any time without notice to you, so you may want to obtain a current copy of 3605 from FMRC. Per the December 1994 publication of 3605, some key definitions and service requirements are as follows:

Repair

A repair constitutes something done internally to the unit that would bring it back to its original condition—Approved by FMRC. A repair should be done in an FMRC Approved facility. Items not considered as repairs are those in which an action is performed on a unit which does not require the outer casing of the unit to be opened in a manner which exposes the

internal electrical circuits of the unit. You do not have to be an FMRC Approved Repair Facility to perform these actions.

Relabeling

The repair facility shall have a method by which the replacement of FMRC Approval labels are controlled to ensure that any relabeling is limited to units that were originally shipped from the Manufacturer with an FM Approval label in place. FMRC Approval labels shall not be stocked by the repair facility. An FMRC Approval label shall be ordered from the original manufacturer, as needed, to repair a specific unit. Replacement labels may be obtained and applied by the repair facility, provided there is satisfactory evidence that the unit being relabeled was originally an FMRC Approved unit. Verification may include, but is not limited to: a unit with a damaged Approval label, a unit with a defective housing displaying an Approval label, or a customer invoice indicating the serial number of the unit and purchase of an FMRC Approved model.

Do Not Substitute Options or Accessories

The Motorola communications equipment certified by Factory Mutual is tested as a system and consists of the FM Approved portable, FM Approved battery, and FM Approved accessories or options, or both. This FM Approved portable and battery combination must be strictly observed. There must be no substitution of items, even if the substitute has been previously Approved with a different Motorola communications equipment unit. Approved configurations are listed in the FM Approval Guide published by FMRC, or in the product FM Supplement. This FM Supplement is shipped from the manufacturer with the FM Approved radio and battery combination. The Approval Guide, or the Approval Standard Class Number 3605 document for repairs and service, can be ordered directly from Factory Mutual Research Corporation located in Norwood, Massachusetts.

Notes

RADIO OVERVIEW

PARTS OF THE RADIO

MTX8250 and MTX9250 Models

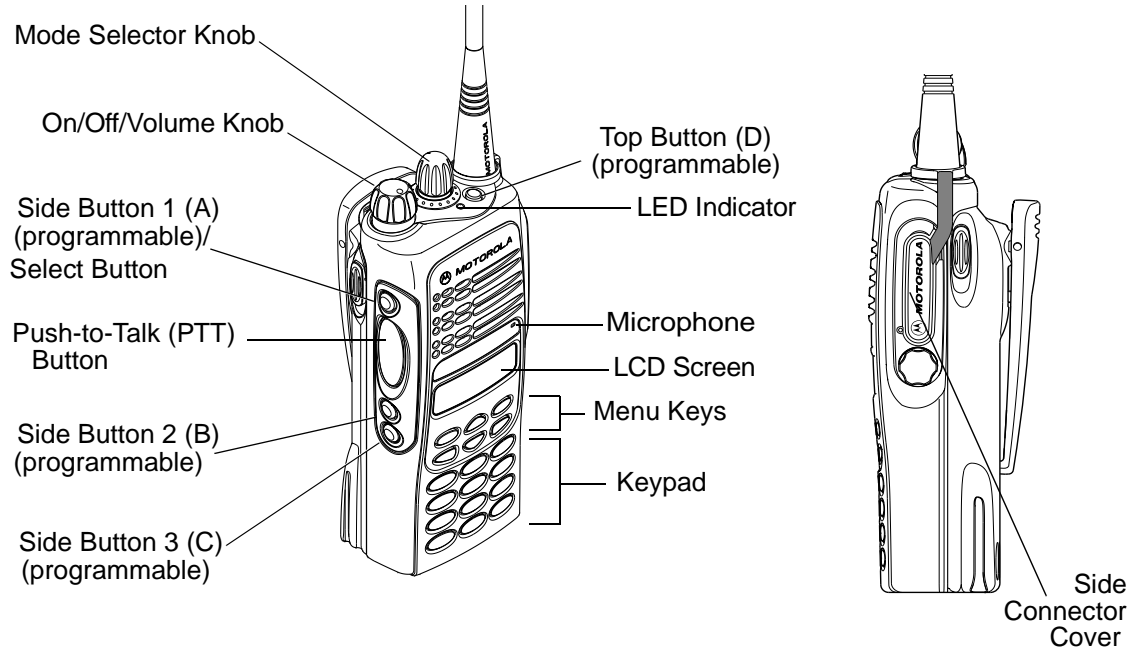

On/Off/Volume Knob

Turns the radio on or off, and adjusts the radio's volume.

Mode Selector Knob

Selects the required operation mode.

Push-to-Talk (PTT) Button

Push and hold down this button to talk; release to listen.

LED Indicator

Indicates status of radio operating conditions (see table below):

With PTT switch pressed (radio transmitting)	
Steady red	Radio is transmitting (PTT button pressed)
LED unlit	Radio is not transmitting
Flashing red	Low battery (conventional mode only; programmable by authorized Motorola dealer).
Momentary green	Radio has powered-up successfully

With PTT Released (radio receiving)

Blinking red	Mode busy (conventional mode only)
Blinking green	Receipt of a telephone call, Private Conversation call, or Call Alert page

Microphone

When sending a message, hold the microphone 1 to 2 inches (2.5 to 5 cm) away from your mouth, and speak clearly into the microphone.

Keypad Keys

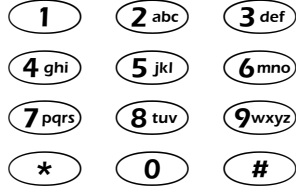

These keys are used for:

- dialing a phone number
- entering a specific radio ID number when making a Private Conversation™ or Call Alert radio call
- programming call lists

The following table shows the character cycle for each key, when entering information for programming the radio's call lists.

Key	Number of Times the Key is Pressed					
	1	2	3	4	5	6
0	0					
1	1	Blank space				

2 abc	A	B	C	2		
3 def	D	E	F	3		
4 ghi	G	H	I	4		
5 jkl	J	K	L	5		
6 mno	M	N	O	6		
7 pqrs	P	Q	R	S	7	
8 tuv	T	U	V	8		
9 wxyz	W	X	Y	Z	9	
*	*					
#	#	-	+	.	/	\

Note: The sequence in the table above is valid when entering information on a blank display. However, when editing existing information, the above sequence may differ. For instance, if the last character entered is an **R**, pressing **7 pqrs** to enter the next character, would start the character cycle at **S** and NOT at **P**.

- When editing existing information, pressing **1** will **ALWAYS** start the character cycle at the *blank space* and **NOT** at 1.

Menu Keys

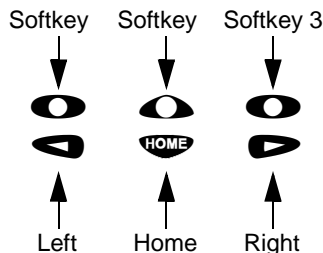

Selecting a Feature

A unique feature of your radio is its use of the display to give you quick access to many of the radio's features without having to have a dedicated key for each feature.

The names of the features (CALL, MUTE, etc.) are shown on the display, three at a time. Selection of features is controlled by the three keys directly below the feature names: the left key controls the left feature, the middle key

controls the middle feature, and the right key controls the right feature.

Softkeys (◐◑◒)

When already in Menu Mode, these keys are used to make Menu selections.

Left and Right Arrow Keys (◀▶)

The left and right arrow keys are used to scroll the display forward or backward through the radio's features and lists. There is no end point to the list, so if you continue to scroll in one direction, the display will "wrap around" back to the beginning of the list. If you hold either key down, the display will scroll at a faster rate until the key is released.

The left arrow key is also used for editing when you are entering information manually from the keypad.

Pressing the left arrow key, when editing numeric information (such as telephone numbers), will backspace, and erase the display, one character at a time. If you have erased all the digits, an additional press of the left arrow key will return the display to the pre-programmed list.

Pressing the left arrow key, when editing alphabetic information (such as member's names), will move the cursor one step to the left.

HOME Key (HOME)

The **HOME** key will always return you to the home (default) display. In most cases, this is the current mode. In addition, if you are using a feature that requires it, pressing the **HOME** key will also cause information to be saved in memory before going to the home display. Some radio features will automatically go to the home display when they are completed, without having to press the **HOME** key, thus reducing the number of key presses required.

Menu Display

The menu items can be displayed in normal video or in reversed video (programmable by your authorized Motorola dealer). All the menu items in the examples in this manual are shown in reversed video.





The order in which the menu items are displayed is programmable. Thus, the order of the menu items on your radio may differ from those shown here in this manual. In such a

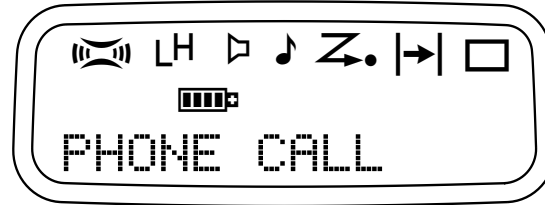

situation, press the relevant softkey to make your menu selections. All descriptions of functions and displays after the selection are valid.

LCD Screen



Displays mode selected, channel, menu, and radio status information. The radio status indicator symbols are explained in the following table.

Symbol	Name and Description
	XPAND™ Indicator Indicates that your radio has the companding feature activated.
	Power Level Indicator L lights up when your radio is configured to transmit in Low Power. H lights up when your radio is configured to transmit in High Power.
	Carrier Squelch Indicator Indicates when the active conventional mode is being monitored in the carrier squelch mode; ON = BEING MONITORED/ OFF = NOT BEING MONITORED.
	Call Received Flashes when a call or page is received.
	Scan Indicator Indicates when the radio is scanning; ON = SCANNING/OFF = NOT SCANNING.

Symbol	Name and Description
	Direct Indicates whether you are talking directly to another radio (talkaround), or through a repeater; ON = DIRECT OFF = REPEATER.
	Programming/Viewing Mode Indicates when the radio is in the programming or viewing mode; ON = IN VIEWING MODE BLINKING = IN PROGRAMMING MODE.
	Battery Level Indicator Shows the remaining charge in your battery, based on how many bars are displayed. Flashing, indicates low battery.

Alert Tone Indications

Your radio generates a number of audible tones to indicate radio operating conditions:

- **Low Battery** – A low-battery condition is indicated by a high-pitched, cricket-like “chirp-chirp” tone when the **PTT** button is released following a transmission.
- **Successful Power-Up** – A short, medium-pitched tone when the radio is first turned on indicates that the radio has passed its power-up self test and is ready for use.
- **Unsuccessful Power-Up** – A short, low-pitched tone when the radio is first turned on indicates that the radio has failed its power-up self test and is not ready for use. Contact your authorized Motorola dealer for service.
- **Transmit on Receive-Only Mode** – If you press the **PTT** button while tuned to a “receive-only” mode, you will hear a continuous, low-pitched alert tone, indicating that no transmission is possible on this mode. This tone will continue until the **PTT** button is released.
- **Transmit Inhibit on Busy Mode** – If you press the **PTT** button while the mode is busy, you will hear a continuous, low-pitched alert tone, indicating that no transmission is possible on this mode. This tone will continue until the **PTT** button is released.
- **Transmit Inhibit on Low Battery** – If you press the **PTT** button when the battery is low, you will hear a continuous, low pitched alert tone, indicating that transmission is impossible.
- **Invalid Mode** – A continuous, low-pitched tone is heard when an invalid or unprogrammed operation is attempted on the radio.
- **Valid (Good) Key Press** – A short, medium-pitched tone when a keypad key is pressed indicates that the key press was accepted.
- **Invalid (Bad) Key Press** – A short, low-pitched tone when a keypad key is pressed indicates that the key press was rejected.

- **Failsoft (Trunked Systems Only)** – A faint “beeping” tone every ten seconds indicates that the radio is operating in the failsoft mode.
- **Time-Out Timer Warning** – Your radio’s time-out timer limits the length of your transmission time. When you are pressing the **PTT** button (transmitting), a short, low-pitched warning tone will sound four seconds before the allotted time will expire.
- **Time-Out Timer Timed-Out** – If you hold down the **PTT** button longer than the time-out timer’s allotted time, a continuous, low-pitched tone will sound, indicating that your transmission has been cut off. This tone will continue until the **PTT** button is released.
- **Phone Busy** – A “bah-bah-bah-bah” tone when telephone interconnect is accessed indicates that all available modes are busy and the radio is in queue for the next available phone line.
- **Call Alert (Page) Received** – A group of four medium-pitched tones every five seconds indicates that your radio has received a Call Alert page.
- **Call Alert (Page) Sent** – A single medium-pitched tone (central acknowledgment), followed by a group of four medium-pitched tones indicates that a Call Alert page sent by your radio has been received by the target radio.
- **Private Conversation Call Received** – A group of two medium-pitched tones indicates that your radio has received a Private Conversation call. This sequence is repeated every five seconds for approximately 20 seconds for enhanced Private Conversation Call.
- **Trunked System Busy (Trunked Systems Only)** – A “bah-bah-bah-bah” tone when a trunked system is accessed indicates that all available channels are busy and the radio is in queue for the next available channel.
- **Call Back (Trunked Systems Only)** – A group of three medium-pitched tones (di-di-dit) indicates that a talkgroup is now available for your previously requested transmission.

Programmable Buttons

Several of your radio's buttons can be programmed by your authorized Motorola dealer as shortcuts to many of the radio's features.

Check with your dealer for a complete list of functions your radio supports.

Programmable buttons include:

- The three Side Buttons (A, B, C)
- Top Button (D)

The table on the following page shows the functions available by:

- **short press**—quickly pressing and releasing the programmable buttons, or
- **long press**—pressing and holding the programmable buttons for a period of time (programmable for 1/2 to 16 seconds), or
- **hold down**—pressing and holding down the programmable buttons while checking status or making adjustments.

In the "Button" column, have your authorized Motorola dealer write down the programmable buttons next to the features that have been programmed to them.

Use the abbreviations (e.g., A for Side Button 1, D for Top Button, etc.) shown in the radio illustration at the front of this manual.

Check with your authorized Motorola dealer for a complete list of features your radio supports.

Feature	Short Press	Long Press	Hold Down	Button
Monitor/ Permanent Monitor	Temporarily monitors the selected channel for any activity.	Continually monitors the selected channel.	Monitors the selected channel for any activity.	
Volume Set	—	—	Sounds a tone for adjusting the radio's volume level.	
Scan	Toggles between the start/stop of the Scan operation.	—	—	
Nuisance Delete	Temporarily deletes an unwanted active scan member.	—	—	
Search	Makes a system search.			
Light	Turns on/off your radio's backlight.	—	—	
Call	Enters or exits a Private call.			
Page	Enters or exits a Call Alert.			
Call Response	Respond to or exit from a Private Call or Call Alert.	—	—	
Phone	Enters or leaves Phone mode.	—	—	

TRUNKED RADIO SYSTEMS

The MTX8250 and MTX9250 radio can operate on both Privacy Plus™ *trunked* and *conventional* radio systems.

Conventional typically refers to radio-to-radio communication, sometimes through a repeater.

A *trunked* radio system allows a large number of users to share a relatively small number of frequencies without interfering with each other.

The air time of all the repeaters in the trunked system is pooled, which maximizes the amount of air time available to any one radio, and minimizes channel congestion.

Some of the benefits of trunked two-way radio systems are:

- No channel monitoring required prior to transmission.
- Improved system access.
- Automatic channel selection.
- Increased privacy among members of the same group.
- Only one attempt is required to access the system. If all channels are busy, the call request enters a queue and the central controller automatically assigns the next available channel. Two (2) medium-pitched tones followed by one (1) high-pitched tone sounds when the call can be made.

Notes

GETTING STARTED

BATTERY INFORMATION

Charging the Battery

If a battery is new, or its charge level is very low (indicated by the battery level indicator showing one or no segments), you will need to charge it before you can use it.

Note: Batteries are shipped uncharged from the factory. Always charge a new battery 14 to 16 hours before initial use, regardless of the status indicated by the charger.

To charge the battery

Place the battery, with or without the radio, in the charger. The charger LED indicates the charging progress:

Charger LED Color	Battery Status
Flashing Red*	Battery unchargeable or not making proper contact.
Steady Red	Battery in rapid-charge mode.
Flashing Yellow	Battery in charger, not in rapid-charge mode but waiting to be charged.
Flashing Green†	Battery 90% (or more) charged.
Steady Green	Battery fully charged.

* Remove the battery from the charger. Clean battery contacts with isopropyl alcohol applied to a soft cloth. Place the battery back in the charger. If the LED indicator continues to flash red, replace the battery.

† A standard battery may require one hour to charge to 90%.

Battery chargers will only charge the Motorola-authorized batteries listed below; other batteries may not charge.

Part No.	Description
HNN9008	High-Capacity/NiMH
HNN9009	Ultra-High-Capacity/NiMH
HNN9010	Ultra-High-Capacity/Factory Mutual/NiMH
HNN9011	High-Capacity/Factory Mutual/ NiCd
HNN9012	High-Capacity/NiCd
HNN9013	High-Capacity/Lithium-Ion

Attaching the Battery

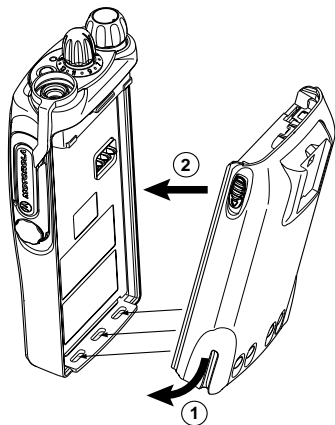

- 1 Fit the extensions at the bottom of the battery into the bottom slots on the radio.
- 2 Press the top part of the battery toward the radio until you hear a click.

Removing the Battery

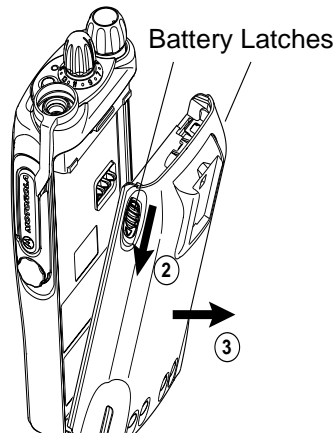

- 1 Turn off the radio (see page 32).
- 2 Slide both battery latches downward.
- 3 Pull the top part of the battery away from the radio.

ACCESSORY INFORMATION

Attaching the Antenna

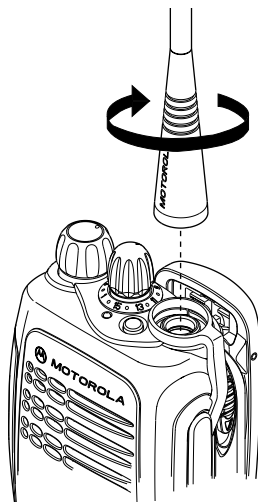

- 1 Turn the antenna clockwise to attach it.

Removing the Antenna

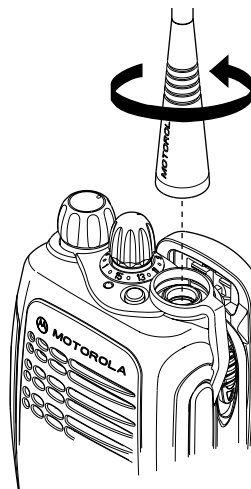

- 1 Turn the antenna counterclockwise to remove it.

Attaching the Belt Clip

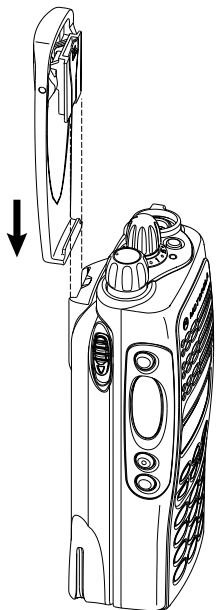

- 1 Align the grooves of the belt clip with those of the battery.
- 2 Press the belt clip downward until you hear a click.

Removing the Belt Clip

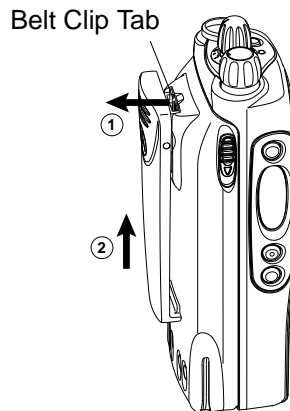

- 1 Use a key to press the belt clip tab away from the battery.
- 2 Slide the belt clip upward to remove it.

Attaching the Side Connector Cover

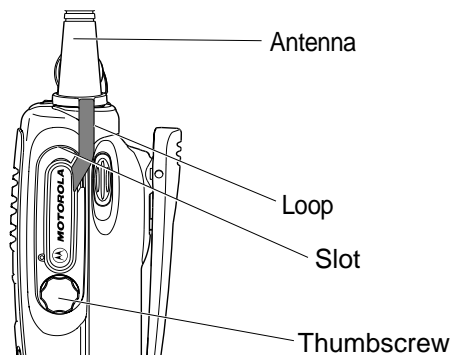

- 1 Place the loop (attached to the side connector cover) over the antenna; then slide it downward until it touches the top of the radio.
- 2 Insert the tab on the top of the cover into the slot above the connector.
- 3 Position the cover over the connector and align the thumbscrew with the threaded hole in the radio.
- 4 Tighten the thumbscrew to hold the cover in place. Do not overtighten the thumbscrew.

TURNING RADIO ON OR OFF

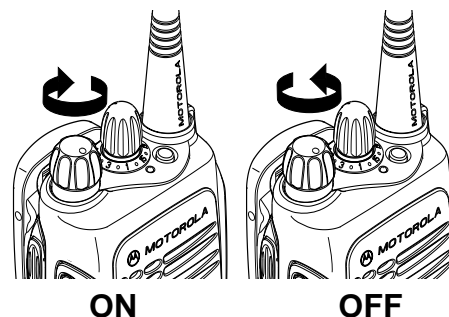

Turn the radio on by rotating the volume control clockwise. The radio goes through a power-up self check and, if it passes the check, the display momentarily shows **SELF TEST**. A good-power-up, high-pitched tone sounds to indicate that the radio has passed the self check.

If the radio fails the self check, the display shows **ERROR XX/XX** (where **XX/XX** is an alphanumeric error code), accompanied by a bad-power-up, low-pitched tone. Turn the radio off, check the battery, and turn the radio back on. If the radio still does not pass the self check, a problem exists in the radio. Contact your authorized Motorola dealer.

ADJUSTING THE VOLUME

Turn the **On/Off/Volume** knob clockwise to increase the volume or counterclockwise to decrease the volume.

—or—

- 1 Hold down the **Volume Set** button (page 24); you will hear a continuous tone.
- 2 Turn the **On/Off/Volume** knob to the desired volume level.
- 3 Release the **Volume Set** button.









SELECTING A TRUNKED OR CONVENTIONAL ZONE

A *mode* is a trunked talkgroup or conventional channel and all the features that are programmed to it. Up to 160 modes can be programmed into your radio.

A *zone* is a grouping of modes that is selected using the menu keys. Up to 16 zones, with a maximum of 15 unique trunked systems, can be programmed into your radio.

Before you use your radio to receive or send messages, you should first select the desired zone and mode.

Selecting a Zone

- 1  until ZONE is displayed. 
- 2  (the softkey below ZONE). The current zone name blinks on the display.  For example:
- 3  until the desired zone name is displayed.  For example:
—or—
Enter the number of the desired zone.
- 4 Press .
- 5 The displayed zone is the new selected zone. 

Note:



is used to indicate the radio's home display.

SELECTING A MODE (EITHER A TRUNKED TALKGROUP OR A CONVENTIONAL CHANNEL)

1 Turn the **Mode Selector** knob to the desired mode.

2 The display shows the selected mode's name. For example:

PLANT MODE 1

3 If the selected mode is unprogrammed, an invalid-mode tone is heard until a valid programmed mode is selected.

UNPROGRAMMED

SENDING A TRUNKED CALL

- 1 Turn the radio on and select the desired trunked zone and talkgroup (see "Selecting a Trunked or Conventional Zone").
- 2 Press and hold the **PTT** button on the side of the radio and speak slowly and clearly into the microphone area. The red LED lights when the radio is transmitting. When you have finished talking, release the **PTT** button to listen.

- If you hear a busy signal (a low-frequency "bah-bah-bah-bah"), release the **PTT** button and wait for a call-back tone (sounds like "di-di-dit"). When you hear the call-back tone you will have three seconds to press the **PTT** button. This allows you to make another call without getting a busy signal.
- If a continuous talk-prohibit tone is heard when the **PTT** button is pressed, transmission is not possible. The radio may be out of range.

SENDING A CONVENTIONAL CALL

- 1 Turn the radio on and select the desired conventional zone and channel (see “Selecting a Trunked or Conventional Zone”).
- 2 Press and hold the **PTT** button on the side of the radio and speak slowly and clearly into the microphone area. The red LED lights continuously when the radio is transmitting.
- 3 When you have finished talking, release the **PTT** button to listen.

Note: In the United States, FCC regulations require you to monitor the conventional channels before sending a call. The monitor feature can be accessed through one of your programmable buttons.

- If the mode-busy feature is enabled, a blinking red LED on receive (**PTT** button released) indicates that the mode is currently busy.
- If a mode is programmed for receive only, any attempt to transmit on that mode will cause an invalid-mode tone to sound until

the **PTT** button is released.

RECEIVING A TRUNKED OR CONVENTIONAL CALL

- 1 Turn your radio on.
- 2 Adjust your radio’s volume.
- 3 Use the **Mode Selector** knob to select the desired trunked talkgroup or conventional channel.
 - Make sure the **PTT** button is released.
- 4 Listen for voice activity. The LED indicator flashes green when your radio is receiving.

FAILSOFT OPERATION (TRUNKED SYSTEMS ONLY)

This feature is programmable by your authorized Motorola dealer.

The “failsoft” system ensures continual radio communications capability during a trunked system failure. Your radio will automatically go into failsoft operation, if the central trunking controller fails for any reason. While in failsoft operation, your radio will transmit and receive on a predetermined frequency on a

conventional mode. When the trunked system returns to normal operation, the radio will automatically leave failsoft operation and return to trunked operation.

During failsoft operation:

- 1 You will hear a faint “beeping” sound every ten seconds. Alternates between:

FAILSOFT

and

PLANT POLICE

- 2 Your radio becomes unscelched.

CODED SQUELCH OPERATION (CONVENTIONAL CHANNELS ONLY)

Tone Private-Line (PL), Digital Private-Line (DPL), and carrier squelch operation are all available in your radio, on a per-mode basis.

When in carrier squelch operation, all traffic on the mode is heard. When in PL or DPL operation, your radio responds to only those messages intended for you. When this feature is mode-slaved, PL, DPL, or carrier squelch is programmed to each mode.

Whenever the radio is operating in carrier squelch, the display will show .

REPEATER OR TALKAROUND MODE (CONVENTIONAL OPERATION ONLY)

This feature allows you to bypass the repeater and talk directly to another portable radio. This is known as the talkaround mode. The transmit frequency is the same as the receive frequency.

- In REPEATER mode, you talk through the repeater, which increases the radio's operating range. The transmit frequency is not the same as the receive frequency.
- If the REPEATER or TALKAROUND feature is programmed to a mode, that mode operates on either repeat or direct operation.
- If the repeat/direct feature is programmed to the keypad, you can change the repeat/direct setting by doing the following.

- 1  until DIR is displayed.

DIR PWR PROG

- 2  (the softkey below DIR).

- 3 The current talkaround state appears on the display for a few seconds.

REPEATER MODE

or

DIRECT MODE
- 4 Then, the display prompts for the new state.

DIR

RPTR
- 5  below the desired talkaround state: repeat (RPTR) or direct (DIR).
- 6 The radio returns to the home display.

DIR

RPTR

VARIABLE RF POWER LEVEL

Radios can have more than one power level. High power can be programmed on modes where high power is permitted, and low power can be programmed on all other modes. The high-/low-power feature can be selected via the radio feature menu.

SMART PTT (CONVENTIONAL OPERATION ONLY)

This feature is programmable by your authorized Motorola dealer.

Smart PTT is a per-mode feature which gives the system manager better control of radio operators. When smart PTT is enabled in your radio, you cannot transmit on an active mode. Three radio-wide variations of smart PTT are available.

- **Transmit Inhibit on Busy Mode**—you are prevented from transmitting if any activity is detected on the mode.
- **Transmit Inhibit on Busy Mode with Wrong Squelch Code**—you are prevented from transmitting on an active mode with a squelch code other than your own. If the PL code is the same as yours, you are allowed to transmit.
- **Quick-Key Override**—This feature can work in conjunction with either of the two above variations. This feature allows you to override the transmit-inhibit state by quick-keying (two **PTT** button presses within a

programmable period – the default is one second – of each other) the radio.

Note: If you try to transmit (press the **PTT** button) on a smart PTT mode that is busy, a continuous alert tone is generated until the **PTT** button is released; the transmission is inhibited.

- The red LED blinks when the radio is receiving indicating that the mode is busy.

MUTING THE KEYPAD TONES

The radio's keypad tones, normally heard each time a keypad key is pressed, can be turned off (muted) or on (unmuted) at your discretion. To use the keypad mute feature:

- 1  until MUTE is displayed.

ZONE MUTE CALL

- 2  (the softkey below MUTE).

You will see the current mute state momentarily

TONES ON

—or—

TONES OFF

Then

ON

OFF

- 3 Press the softkey below the desired mute state (on or off). The radio returns to the home display.

PLANT POLICE

Note: Pressing  or the **PTT** button will exit this menu without changing the mute selection.

RADIO CALLS (TRUNKED OPERATION ONLY)







Note:

PLANT POLICE

is used to indicate the radio's home display.

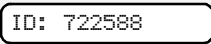
VIEWING YOUR RADIO'S ID NUMBER

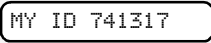
To view your radio's ID number:

- 1  until CALL is displayed. 
- 2  (the softkey below CALL).
- 3 The display shows the last ID number transmitted or received. 
- 4 Press .
- 5 The display shows your radio's ID number. 
- 6 Press  to return the radio to the home display. 

Note: If your radio has been so programmed, you can press the **Call** button for quick access to viewing your radio's ID number. This takes you directly to step 3.

ENHANCED PRIVATE CALL OPERATION

The Enhanced Private Conversation™ Call feature not only allows you to have a conversation that is heard only by the two parties involved, but also enables you to determine whether the radio that you are calling is in service. The radio being called can also view the calling radio's ID number before answering. You can then choose whether or not to leave your radio's ID number (via a Call Alert page) with the radio you are calling so that you may be called back. Enhanced Private Conversation operation is similar to telephone operation.

Receiving a Private Conversation Call

1 Upon receiving a Private Conversation Call, two alert tones will sound (repeating every 5 seconds for 20 seconds).

Alternates between:

CALL

and

PLANT POLICE

2 The green LED and call received status annunciator, , will blink indicating that a call is being received. You have 20 seconds to answer the call before the radio automatically returns to the home display.

3 Press the call response button or the call button.

Note: If you press the **PTT** button before you press the call response button, the response will be transmitted to everyone in the talkgroup (a dispatch mode operation).

4 The display shows the incoming caller's ID number, and the call received annunciator will turn off.

ID: 722588

5 After viewing the caller's ID number, you can decide to either talk privately (go to next step), or not answer the call by pressing the call response or call button to return to the home display.

6 If you decide to answer the call, press the **PTT** button.

7 The caller's ID number remains displayed for the duration of the call.

ID: 722588

8 When finished with conversation, press  or the call response button to hang up.

9 The radio will return to the home display.



PLANT POLICE

- After answering a Private Conversation Call, the caller's ID number is stored in your radio as the last ID number received.
- If your radio is configured for Private Call II, upon receiving a Private Conversation Call, two alert tones will sound, followed by the received voice.

Sending a Private Conversation Call

There are four steps in sending a Private Conversation Call:

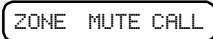
1. Initiating a Private Conversation Call

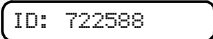
- 1  until CALL is displayed. 
- 2  (the softkey below CALL).
- 3 The display shows the last ID number transmitted or received. 



2. Entering the Desired Radio ID Number

If the last ID number called is the desired number, go directly to step 5.





To enter a new number

- 4a Enter the new six-digit ID number using the keypad.
- 4b On the display, the old ID number disappears and the new digits appear as they are being entered.
- 4c The cursor flashes indicating the location of the next number to be entered

Note: Exactly six digits must be entered for the radio ID number. If fewer than six digits were entered, you will hear a bad-keypress tone, and the display will show `INVALID ENTRY` when attempting to send the radio ID number. A bad-keypress tone will also be heard if you try to enter a seventh digit.

Once you have started entering numbers, the  key functions as a backspace key. Pressing it causes the last digit entered to be erased, and the cursor moves to the left. When the last digit is erased, an additional press of this key causes the last member of the preprogrammed call list to be displayed. Pressing  shows the first member of the list.

To enter a number from the call list

- 4a  or  to enter the call list.
- 4b  takes you to the first or next member of the list;  takes you backwards to the last or previous member of the list.

4c When at a member of the list, the display alternates between showing the member's name and ID number.



Alternates between:

CK TANG

and

ID: 784116

To enter a number from a location in the call list

- 4a**  or  to enter the call list.
- 4b** Enter the first digit of the location number. If there are fewer than 10 members in the list, go directly to step 4e.
- 4c** If there are 10 or more members in the list, the display shows ID LOC#X_ (where X is the first digit). The cursor blinks to show the location of the second digit.
- 4d** Enter the second digit of the location number.
- 4e** The radio goes to that position in the list. The display alternates between showing the member's name and ID number.
- Alternates between:
- CK TANG
- and
- ID: 784116

Note: The last member of the list is also the last ID transmitted or received at position 00 on the list.

If you enter a location number that does not exist (for example, 15), the display will show INVALID ENTRY, and the radio will sound an invalid-keypress tone and return back to step 4b of this procedure.

3. Sending the Radio ID Number

- 5** Press the **PTT** button to transmit the ID number.
- 6** If the radio you are calling is on the air, you will hear a telephone-type ringing for 20 seconds, or until the party you are calling answers the call.
- 7** If the party you are calling does not answer the call within twenty seconds, the telephone ringing stops and an alert tone sounds.
- NO ANSWER
- At this point you can either send a Call Alert page, or go to step 10 to hang up.

- 8 If the party you are calling answers the call, you will hear his/her voice.

Note: If the radio you are calling is not in service, you will not hear the ringing and the display will show **NO ACK**. Go to step 10 to hang up.

If your radio is configured for Private Call II, you will not hear the telephone type ringing. Instead you are able to proceed to talk to the Called party.

4. Having the Private Conversation Call and Hanging-up

- 9 Press the **PTT** button to have a Private Conversation Call with the called person.
- 10 When finished with your conversation, or if the radio you called does not answer or is not in service, press **HOME** to hang up.
- 11 The radio will return to the home display. 

Note: Once engaged in a private conversation, if the radio is left idle for more than one minute, a momentary warn-

ing alert sounds every six seconds to remind you that dispatch calls are not able to be heard. After two minutes, a permanent invalid mode tone sounds.



Option to Leave a Call Alert Page

- 1 If the party you want to have a Private Conversation Call with does not answer the call within twenty seconds, you can choose to leave a Call Alert page. This leaves your radio's ID number with the called radio so you can be called back later.
- 2 Press the **PTT** button to send the Call Alert page. You will hear five beeps, indicating that the system has received your ID number, and the radio you are calling is on the air.
- 3 Press **HOME**.
- 4 The radio will return to the home display. 

CALL ALERT OPERATION

The Call Alert feature enables your radio to function like a pager (beeper), allowing you to send pages to other radios, and to receive and respond to pages from other radios.

Receiving a Call Alert Page with a Group Call



- 1 When a Call Alert page is received, four alert tones will sound (repeats every 5 seconds).
- 2 The green LED lights and the Call Received annunciator, , blinks indicating a call is received.
- 3 Press the **PTT** button to answer the page.
- 4 The display shows the current talkgroup. The audible alert, LED, and call received annunciator turns off. 
- 5 The ID number of the radio that paged you is stored as “the last ID number received.”
- 6 Begin your conversation; all members of your talkgroup will hear your response. Press the **PTT** button to talk; release the button to listen.

Note: When you receive a Call Alert page, you can enter Private Conversation Call mode and call the paging radio using the latest ID received.

Sending a Call Alert

There are three steps in sending a Call Alert:

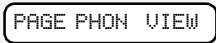
1. *Initiating a Call Alert*

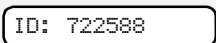
- 1  until PAGE is displayed. 
- 2  (the softkey below PAGE).
- 3 The display shows the last ID number transmitted or received. 

Note: The same list is shared by both Call Alert and Private Conversation Call features.

If your radio has been so programmed, you can press the page button for quick access to the Call Alert feature. This will take you directly to step 3, above.



2. *Entering the Radio ID Number that you Wish to Page*

If the last ID number called or received is the desired number, go directly to step 5.





To enter a new number

- 4a Enter the new six-digit ID number using the keypad.
- 4b On the display, the old ID number disappears and the new digits appear as they are being entered.
- 4c The cursor flashes indicating the location of the next number to be entered.

Note: Exactly six digits must be entered for the radio ID number. If fewer than six digits were entered, you will hear a bad-keypress tone when attempting to send the radio ID number. A bad-keypress tone will also be heard if you try to enter a seventh digit.

Once you have started entering numbers, the  key functions as a backspace key. Pressing it causes the last digit entered to be erased, and the cursor moves to the left. When the last digit is erased, an additional press of this key causes the last member of the preprogrammed call list to be displayed; pressing  shows the first member of the list.

To enter a number from the call list

- 4a  or .
- 4b  takes you forward to the first or next member of the list;  takes you backwards to the last or previous member of the list.

- 4c When at a member of the list, the display alternates between showing the member's name and ID number.



Alternates between:

CK TANG

and

ID: 784116

To enter a number from a location in the call list

- 4a  or  to enter the call list.
- 4b Enter the first digit of the location number. If there are fewer than 10 members in the list, go directly to step 4e.
- 4c If there are 10 or more members in the list, the display shows ID LOC#X_ (where X is the first digit). The cursor blinks to show the location of the second digit.
- 4d Enter the second digit of the location number.

4e The radio goes to that position in the list. The display alternates between showing the member's name and ID number.

Alternates between:

CK TANG

and

ID: 784116

Note: The last member of the list is also the last ID transmitted or received at position 00 on the list.

If you enter a location number that does not exist (for example, 15), the display will show `INVALID ENTRY`, and the radio will sound an invalid-keypress tone and return back to step 4b, above, of this procedure.

3. Sending the Call Alert

- 5** Press the **PTT** button to transmit the ID number.

If the page is successful

- 6a** If you hear five beeps, the ID number has been received by the system, and the radio you are paging is on the air and has received your page.
- 6b** The radio automatically returns to the home display PLANT POLICE

If the page is unsuccessful

- 6a** If you hear one beep, the ID number has been received by the system, but the radio you are paging is not on the air; your radio remains in the Call Alert mode.







If after six seconds the called radio fails to acknowledge the alert, a low-pitched alert tone sounds and the display changes to `NO ACKNOWLEDGE`.
- 6b** Press the **PTT** button to send the ID number again, or press **HOME** to hang up and return to the home display.

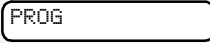

PROGRAMMING THE RADIO'S CALL LISTS



Programming the Telephone List Numbers

This feature allows you to use the radio's keypad to change the telephone numbers assigned to any of the telephone list members. Each phone number can have up to 16 digits.

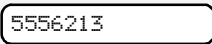
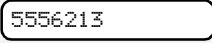
To change the telephone list

- 1  until PROG is displayed. 
- 2  (the softkey below PROG). 
- 3  (the softkey below PHON). The display shows the first programmable member of the telephone list. 
- 4  or ,
—or—
Use the keypad to enter the desired member's position number (1 to 19) to view the other members of the telephone list.

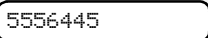
- 5 When you stop on a member of the list, the display will alternate between showing the member's name and telephone number. Alternates between:

and

- 6 Press the select key to enter edit mode.
- 7 A short press would enable the editing of the telephone number. The display shows the current member's telephone number. 
- 8 A long press would enable the editing of the member's name. The display shows the current member's name. 
- 9 Use any of the alphanumeric keys to make the changes. The blinking cursor indicates the position of the next number to be added. If you require a pause in the phone dialing sequence (to allow for a delay), you can do so by first pressing the * key, followed by pressing the # key. The display will show a P for pause.

- 10 When you have finished changing the telephone number, press the select key again. The change is saved in the radio's memory.
- 11 You are returned to step 5. The display will again alternate between  and  showing the member's name and telephone number. You can now change additional numbers.
- 12 When you have finished making changes, press  to exit program mode.
- 13 The radio will return to the home display. 

Note: The programming-mode annunciator, , blinks while program mode is active.

In the edit mode, the  key functions as a backspace key. Pressing it will erase the previous digit, and the cursor will move to the left. When the last digit on the display has been erased, additional presses of this key or





the  key will cause you to leave the edit mode without making any changes.

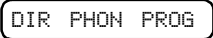

You can only enter a maximum of 16 digits in any entry for the telephone list. When this maximum is reached, the cursor will disappear. If you try to add any more digits, you will hear an invalid (bad) keypress alert tone.

Programming the Call List

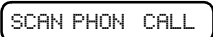
This feature allows you to use the radio's keypad to change the radio ID numbers assigned to the call list used by the trunked Private Conversation and Call Alert features.

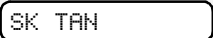
To change the call list radio ID numbers

- 1  until PROG is displayed. 
- 2  (the softkey below PROG). 
- 3  (the softkey below CALL). The display shows the first programmable member of the call list. 

- 4  or 
—or—

Use the keypad to enter the desired member's position number (1 to 19) to view the other members of the call list.

- 5 When you stop on a member of the list, the display will alternate between showing the member's name and radio ID number.

Alternates between:

CT CHAN

and

ID: 753951

- 6 Press the **Select** key to enter edit mode.

- 7 A short press would enable the editing of the radio ID. The display shows the current member's radio ID number.

ID: 753951

- 8 A long press would enable the editing of the member's name. The display shows the current member's name.

CT CHAN

- 9 Use any of the alphanumeric keys to make the changes. The blinking cursor indicates the position of the next number to be added.

- 10 When you have finished changing the number, press the **Select** key again. The change is saved in the radio's memory.

- 11 You are returned to step 5. The display will again alternate between showing the member's name and radio ID number. You can now change additional numbers.

Alternates between:

CT CHAN

and

ID: 753853

- 12 When you have finished making changes, press  to exit program mode.

- 13 The radio will return to the home display.

PLANT POLICE

Note: The programming-mode annunciator, , blinks while program mode is active.

In the edit mode, the  key functions as a backspace key. Pressing it will erase the previous digit, and the cursor will move to the

left. When the last digit on the display has been erased, additional presses of this key or the  key will cause you to leave the edit mode without making any changes.

When the maximum number of digits for the radio ID is reached, the cursor will disappear. If you try to add any more digits, you will hear an invalid (bad) keypress alert tone.

TRUNKED TELEPHONE OPERATION

The trunked telephone feature allows you to receive calls using your trunked radio. When you are dialing from the keypad, your radio may be programmed with either buffered dial (you enter all digits and press the **PTT** button before the digits are sent out) or live dial (each digit is sent out as it is pressed).

Receiving a Telephone Call



- 1 When a telephone call is received, you will hear a ringing tone.

Alternates between:

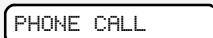

and





- 2 Press the pre-programmed **Phone** button or call response button to answer the call. 
- 3 Begin your conversation. Press the **PTT** button to talk; release the **PTT** button to listen.
- 4 When you have finished your conversation, press  or the phone button to hang up.
- 5 The radio will return to the home display. 

Note: The call received status annunciator, , flashes when you receive a call, but is not displayed when you answer the call.

Sending a Telephone Call

There are three steps in sending a phone call:

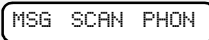
1. *Accessing the Telephone System*

- 1  until PHON is displayed. 
- 2  (the softkey below PHON).

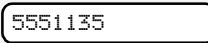
- 3 Your radio attempts to access the telephone system.
- 4 If you connect successfully, you will hear a dial tone.
- 5 The display will show the last number dialed. 





2. Sending the Telephone Number

Sending the telephone number using the keypad

- 6a The number can now be entered from the keypad, using any of the numeric (0 – 9) keys, and the * and # keys. The cursor flashes to indicate the location of the next digit to be entered. A pause can be entered in the telephone number by first pressing the * key, then the # key (buffered dial only - The pause will be shown on the display as a P).
- 6b If your radio is programmed for “live dial,” each digit is sent out as its key is pressed.
—or—
If your radio is programmed for buffered dial, each digit is temporarily stored as you enter them. After entering the number, press the PTT button to send out the number.

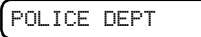
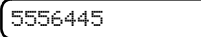
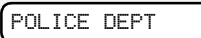

- 6c The telephone number will be sent out; you will hear tones as they are sent. If you hear a busy signal, go to step 8 for hang-up procedure.

Sending the telephone number using a number in the telephone list

- 6a  or  to enter the telephone list.  takes you forward to the next member of the list;  takes you backwards to the previous member of the list.
- 6b Stop at the member you wish to call.
- 6c The display alternates between showing the member's name and telephone number. Alternates between:  and 
- 6d Press the PTT button.
- 6e The telephone number will be sent out; you will hear tones as they are sent. 

6f If you hear a busy signal, go to step 8 for hang-up procedure.

Sending the telephone number using a location in the telephone list

6a  or , to enter the telephone list.

6b Enter the location (any preprogrammed location from 1 through 19) of the number you wish to call.

6c The radio will go to the selected location.

6d The display alternates between showing the member's name and telephone number. Alternates between:

POLICE DEPT

and

5556445

6e Press the **PTT** button.

6f The telephone number will be sent out; you will hear tones as they are sent.

POLICE DEPT

6g If you hear a busy signal, go to step 8 for hang-up procedure.

3. *Having the Conversation and Hanging Up*

7 If call is answered, communicate in the normal manner. Press the **PTT** button to talk; release the **PTT** button to listen.



8 When finished with your conversation, or if the number you called is busy or does not answer, press  or the **Phone** button to send the hang-up code.

9 The radio will return to the home display.

PLANT POLICE

Notes:

- You can press the pre-programmed phone button for quick access to the telephone call feature. This will take you directly to step 3.
- The PLEASE WAIT message is a timed message. If you cannot access the telephone system (no dial tone heard), press  key or the **Phone** button to hang up, and start again at step 1 of this procedure.
- If you are out of range of the trunked system or the phone interconnect is out of service, NO PHONE is displayed and a continuous low-pitched tone sounds.

- If the trunked phone interconnect is in use, a busy tone sounds and **PHONE BUSY** is displayed.
- When the maximum number of digits have been entered (buffered dial only), the cursor will disappear.
- In the edit mode, the  key functions as a backspace key. Pressing this key erases the last digit entered, and moves the cursor to the left. When the last digit on the display is erased, additional presses of this key causes the last member of the preprogrammed telephone list to be displayed; pressing the  key displays the first member of the list.
- After reaching the number you are calling, you may need to dial an extension number before you can reach your party. Here, enter the extension number from the keypad or (if so programmed) use the arrow keys to find the extension number in the telephone list. If you have live dial, the number is sent as the keys are pressed. If you have buffered dial, press the **PTT** button again to send out the extension number.
- Motorola trunked radios generate a high-pitched go-ahead tone when the system's **PTT** button is released. This is heard by the land-line party and is an indicator to begin talking.

Notes

RADIO CALLS
(TRUNKED
OPERATION ONLY)

SCAN

SCAN OPERATION

Note:

PLANT POLICE

is used to indicate the radio's home display.

The scan feature allows you to monitor activity on different conventional or trunked modes by scanning a *scan list* of modes. This list can be programmed by your authorized Motorola dealer and is user programmable.

The table below lists the types of scan operations available.

Conventional	Comprises conventional-only modes.
Talkgroup Scan	Comprises conventional modes and trunked modes from more than one trunking system.

Automatic scanning (autoscan) can be programmed by your authorized Motorola dealer. If autoscan is enabled for a mode, your

radio begins scanning, using the mode's scan list, whenever you select that mode. The radio will continue autoscanning until you select a mode that does not have autoscan enabled.

Turning Scan On or Off with the Keypad

- 1  until SCAN is displayed.

PHON SCAN CALL

- 2  (the softkey below SCAN).

You will see the current scan state momentarily.

SCAN ON

or

SCAN OFF

Then

ON OFF

- 3 Press the softkey below the desired scan state (on or off). The radio returns to the home display.

PLANT POLICE

Note: The scan status annunciator, , is displayed when the scan operation is active. It will be removed from the display when the scan operation is terminated.

Deleting Nuisance Modes







When the radio scans to a mode you do not wish to monitor (nuisance mode), you can temporarily delete that mode from the scan list.

- 1 When your radio is locked on the mode to be deleted, press the nuisance-mode delete button (programmed by your authorized Motorola dealer).
- 2 A valid-keypress chirp is heard, indicating that the mode has been deleted.
- 3 The radio continues scanning the remaining modes in the list.
- 4 To resume scanning the deleted mode, you must leave and reenter scan operation.

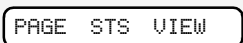

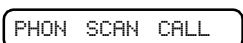
Viewing a Scan List

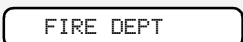
The “view scan list” feature allows you to view the members of the scan list associated with the currently selected mode.

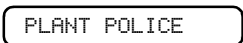
To view a scan list

- 1  until VIEW is displayed. 
- 2  (the softkey below VIEW). 
- 3  (the softkey below SCAN). The display shows the first member of the scan list. For example: 
- 4 Every subsequent press of  will scroll through subsequent members of the scan list.
- 5 To leave the scan list feature, press , or the **PTT** button, or turn the **Mode Selector** knob.
- 6 The radio returns to the home display. 





Notes:





- The programming-mode annunciator, , is displayed while list view mode is active.
- The scan status annunciator, , appears, indicating that a scan list is being viewed.

Programming a Scan List

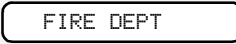

The program scan list feature allows you to program the members of the scan list associated with the currently selected mode.

To program a scan list

- 1  until PROG is displayed. 
- 2  (the softkey below PROG). 
- 3  (the softkey below SCAN). The display shows the current mode selected.  For example:
- 4 Use the mode selector knob to select the required talkgroup zone.

- 5  or  to select the required zone. If the scan status annunciator, , is displayed, the mode is part of the scan list.
- 6 Press the select key to enable or disable the scan mode.
- 7 After making all the changes, select the required operating mode.
- 8 Press , or the **PTT** button, or turn the **Mode Selector** knob to commit all the changes made.

Notes:

- The programming-mode annunciator, , is displayed while program mode is active.
- The scan status annunciator, , appears, indicating that a scan list is being viewed.

Notes

WARRANTY

LIMITED WARRANTY MOTOROLA COMMUNICATION PRODUCTS

I. WHAT THIS WARRANTY COVERS AND FOR HOW LONG:

MOTOROLA INC. (“MOTOROLA”) warrants the MOTOROLA manufactured Communication Products listed below (“Product”) against defects in material and workmanship under normal use and service for a period of time from the date of purchase as scheduled below:

MTX8250 and MTX9250 Portable Units	Two (2) Years
Product Accessories	One (1) Year

Motorola, at its option, will at no charge either repair the Product (with new or reconditioned parts), replace it (with a new or reconditioned Product), or refund the purchase price of the Product during the warranty period provided it is returned in accordance with the terms of this warranty. Replaced parts or boards are warranted

for the balance of the original applicable warranty period. All replaced parts of Product shall become the property of MOTOROLA.

This express limited warranty is extended by MOTOROLA to the original end user purchaser only and is not assignable or transferable to any other party. This is the complete warranty for the Product manufactured by MOTOROLA.

MOTOROLA assumes no obligations or liability for additions or modifications to this warranty unless made in writing and signed by an officer of MOTOROLA. Unless made in a separate agreement between MOTOROLA and the original end user purchaser, MOTOROLA does not warrant the installation, maintenance or service of the Product.

MOTOROLA cannot be responsible in any way for any ancillary equipment not furnished by MOTOROLA which is attached to or used in connection with the Product, or for operation of the Product with any ancillary equipment, and all such equipment is expressly excluded from this warranty. Because each system which may use the Product is unique, MOTOROLA disclaims liability for range, coverage, or operation of the system as a whole under this warranty.

II. GENERAL PROVISIONS:

This warranty sets forth the full extent of MOTOROLA'S responsibilities regarding the Product. Repair, replacement or refund of the purchase price, at MOTOROLA's option, is the exclusive remedy. THIS WARRANTY IS GIVEN IN LIEU OF ALL OTHER EXPRESS WARRANTIES. IMPLIED WARRANTIES, INCLUDING WITHOUT LIMITATION, IMPLIED WARRANTIES OF MERCHANTABILITY AND FITNESS FOR A PARTICULAR PURPOSE, ARE LIMITED TO THE DURATION OF THIS LIMITED WARRANTY. IN NO EVENT SHALL MOTOROLA BE LIABLE FOR DAMAGES IN EXCESS OF THE PURCHASE PRICE OF THE PRODUCT, FOR ANY LOSS OF USE, LOSS OF TIME, INCONVENIENCE, COMMERCIAL LOSS, LOST PROFITS OR SAVINGS OR OTHER INCIDENTAL, SPECIAL OR CONSEQUENTIAL DAMAGES ARISING OUT OF THE USE OR INABILITY TO USE SUCH PRODUCT, TO THE FULL EXTENT SUCH MAY BE DISCLAIMED BY LAW.

III. STATE LAW RIGHTS:

SOME STATES DO NOT ALLOW THE EXCLUSION OR LIMITATION OF INCIDENTAL

OR CONSEQUENTIAL DAMAGES OR LIMITATION ON HOW LONG AN IMPLIED WARRANTY LASTS, SO THE ABOVE LIMITATION OR EXCLUSIONS MAY NOT APPLY.

This warranty gives specific legal rights, and there may be other rights which may vary from state to state.

IV. HOW TO GET WARRANTY SERVICE:

You must provide proof of purchase (bearing the date of purchase and Product item serial number) in order to receive warranty service and, also, deliver or send the Product item, transportation and insurance prepaid, to an authorized warranty service location. Warranty service will be provided by Motorola through one of its authorized warranty service locations. If you first contact the company which sold you the Product (e.g., dealer or communication service provider), it can facilitate your obtaining warranty service. You can also call Motorola at 1-800-927-2744 US/Canada.

V. WHAT THIS WARRANTY DOES NOT COVER:

- A) Defects or damage resulting from use of the Product in other than its normal and customary manner.
- B) Defects or damage from misuse, accident, water, or neglect.
- C) Defects or damage from improper testing, operation, maintenance, installation, alteration, modification, or adjustment.
- D) Breakage or damage to antennas unless caused directly by defects in material workmanship.
- E) A Product subjected to unauthorized Product modifications, disassemblies or repairs (including, without limitation, the addition to the Product of non-Motorola supplied equipment) which adversely affect performance of the Product or interfere with Motorola's normal warranty inspection and testing of the Product to verify any warranty claim.
- F) Product which has had the serial number removed or made illegible.
- G) Rechargeable batteries if:
 - 1) any of the seals on the battery enclosure of cells are broken or show evidence of tampering.
 - 2) the damage or defect is caused by charging or using the battery in equipment or service other than the Product for which it is specified.
- H) Freight costs to the repair depot.
- I) A Product which, due to illegal or unauthorized alteration of the software/firmware in the Product, does not function in accordance with MOTOROLA's published specifications or the FCC type acceptance labeling in effect for the Product at the time the Product was initially distributed from MOTOROLA.
- J) Scratches or other cosmetic damage to Product surfaces that does not affect the operation of the Product.
- K) Normal and customary wear and tear.

VI. PATENT AND SOFTWARE PROVISIONS:

MOTOROLA will defend, at its own expense, any suit brought against the end user purchaser to the extent that it is based on a claim that the Product or parts infringe a United States patent, and MOTOROLA will pay those costs and damages finally awarded against the end user purchaser in any such suit which are attributable to any such claim, but such defense and

payments are conditioned on the following:

- A) that MOTOROLA will be notified promptly in writing by such purchaser of any notice of such claim;
- B) that MOTOROLA will have sole control of the defense of such suit and all negotiations for its settlement or compromise; and
- C) should the Product or parts become, or in MOTOROLA's opinion be likely to become, the subject of a claim of infringement of a United States patent, that such purchaser will permit MOTOROLA, at its option and expense, either to procure for such purchaser the right to continue using the Product or parts or to replace or modify the same so that it becomes non-infringing or to grant such purchaser a credit for the Product or parts as depreciated and accept its return. The depreciation will be an equal amount per year over the lifetime of the Product or parts as established by MOTOROLA.

MOTOROLA will have no liability with respect to any claim of patent infringement which is based upon the combination of the Product or parts furnished hereunder with software, apparatus or devices not furnished by MOTOROLA, nor will MOTOROLA have any liability for the use of ancillary equipment or software not furnished by MOTOROLA which is attached to or used in

connection with the Product. The foregoing states the entire liability of MOTOROLA with respect to infringement of patents by the Product or any parts thereof.

Laws in the United States and other countries preserve for MOTOROLA certain exclusive rights for copyrighted MOTOROLA software such as the exclusive rights to reproduce in copies and distribute copies of such Motorola software. MOTOROLA software may be used in only the Product in which the software was originally embodied and such software in such Product may not be replaced, copied, distributed, modified in any way, or used to produce any derivative thereof. No other use including, without limitation, alteration, modification, reproduction, distribution, or reverse engineering of such MOTOROLA software or exercise of rights in such MOTOROLA software is permitted. No license is granted by implication, estoppel or otherwise under MOTOROLA patent rights or copyrights.

VII. GOVERNING LAW:

This Warranty is governed by the laws of the State of Illinois, USA.

ACCESSORIES

Motorola offers a number of accessories to enhance the productivity of your two-way radio. Many of the available accessories are listed below. Your authorized Motorola dealer will also have a complete list of accessories.

CARRY CASES

HLN9714_	Spring 2 1/2" Belt Clip
HLN9952_	Belt Clip Carry Holder
HLN9677_	Leather DTMF Case, Thin Battery with Belt Loop
HLN9689_	Leather DTMF Case, Standard Battery with Belt loop
HLN9690_	Leather DTMF Case, Thin Battery with Swivel
HLN9694_	Leather DTMF Case, Standard Battery with Swivel
HLN9701_	Nylon Case, Thin Battery with Belt Loop (compatible with all batteries)

HEADSETS

AARMN4018_	Lightweight Headset with Boom Microphone & In-Line PTT.
AARMN4031_	Lightweight Headset with Swivel Boom Microphone
AARMN4017_	Ultra-Light Headset
AARMN4019_	Over-the-Head, Medium-Weight, Dual Muff Headset With Noise Cancelling Microphone & In-Line PTT
AARMN4032_	Over-the-Head, Medium-Weight, Dual Muff Headset With Noise Cancelling Microphone

REMOTE SPEAKER MICROPHONES

AAHMN9052_	Standard Remote Speaker Microphone
AAHMN9053_	Noise-Cancelling Remote Speaker Microphone

ADAPTERS

AAHLN9716_	Adapter for Audio Accessories
------------	-------------------------------

EARPIECES

AARMN4022_	Two Wire Earpiece with Microphone & PTT (Beige)
AARMN4029_	Two Wire Earpiece with Microphone & PTT (Black)
AARMN4021_	One Wire Earpiece (Beige)
AARMN4028_	One Wire Earpiece (Black)
RLN4941_	Receive-Only Earpiece with Translucent Tube, Rubber Eartip and 3.5 mm Plug (For use with AAHMN9053)
RLN4922_	Completely Discrete Earpiece Kit-use with any standard two wire earpiece kit

COMMPORT: INTEGRATED MICROPHONE/RECEIVER

CommPort Integrated Microphone/Receiver System is a communication device that is intelligible in high noise levels up to 10dB. This device's acoustic technology does not rely on bone conduction for communication.

NTN1722_	Integrated Ear Microphone/Receiver System with PTT
NTN1723_	Integrated Ear Microphone/Receiver System with Palm PTT
NTN1724_	Integrated Ear Microphone/Receiver System with Ring PTT

BATTERIES

HNN9008_R	Small NiMH, High-Capacity
HNN9009_R	Large NiMH, Ultra-High-Capacity
HNN9010_R	Large NiMH, Ultra-High-Capacity FM
HNN9011_R	Large NiCd, High-Capacity FM
HNN9012_R	Large NiCd, High-Capacity
HNN9013_R	Slim Li-Ion, High-Capacity

CHARGERS

AAHTN3000_	110V Single-Unit Rapid Charger, US Plug
AAHTN3003_	110V Multi-Unit Rapid Charger, US Plug

ANTENNAS

NAF5037_	800 MHz 1/2 Wave Whip Antenna, 806 - 870 MHz
NAF5042_	800 MHz 1/4 Wave Whip Antenna, 806 - 941 MHz
NAF5038_	900 MHz 1/2 Wave Whip Antenna, 896 - 941 MHz



Motorola, the stylized M logo, Professional Radio - As Dedicated As You Are, Privacy Plus, and Private Conversation are trademarks of Motorola, Inc. © Reg. U.S. Patent & Trademark Office.
© 2000, 2001 Motorola, Inc. All rights reserved. Printed in U.S.A.

Motorola, le logo stylisé M, Radio Professionnelle - et Aussi spécialisée que vous l'êtes sont, Privacy Plus, et Private Conversation des marques de commerce de Motorola, Inc. MD Marque déposée.
U.S. Patent & Trademark Office.
© 2000, 2001 Motorola, Inc. Tous droits réservés. Imprimé aux États-Unis.



68P81093C90-B