



Artisan Technology Group is your source for quality new and certified-used/pre-owned equipment

- FAST SHIPPING AND DELIVERY
- TENS OF THOUSANDS OF IN-STOCK ITEMS
- EQUIPMENT DEMOS
- HUNDREDS OF MANUFACTURERS SUPPORTED
- LEASING/MONTHLY RENTALS
- ITAR CERTIFIED SECURE ASSET SOLUTIONS

SERVICE CENTER REPAIRS

Experienced engineers and technicians on staff at our full-service, in-house repair center

*InstraView*SM REMOTE INSPECTION

Remotely inspect equipment before purchasing with our interactive website at www.instraview.com ↗

WE BUY USED EQUIPMENT

Sell your excess, underutilized, and idle used equipment. We also offer credit for buy-backs and trade-ins. www.artisanng.com/WeBuyEquipment ↗

LOOKING FOR MORE INFORMATION?

Visit us on the web at www.artisanng.com ↗ for more information on price quotations, drivers, technical specifications, manuals, and documentation

Contact us: (888) 88-SOURCE | sales@artisanng.com | www.artisanng.com

User Manual
3152
PRECISION PLL SYNTHESIZER
Publication No. 980793

RACAL INSTRUMENTS

Racal Instruments, Inc.

4 Goodyear St., Irvine, CA 92618-2002
Tel: (800) RACAL-ATE, (800) 722-2528, (949) 859-8999; FAX: (949) 859-7139

Racal Instruments, Ltd.

480 Bath Road, Slough, Berkshire, SL1 6BE, United Kingdom
Tel: +44 (0) 1628 604455; FAX: +44 (0) 1628 662017

Racal Systems Electronique S.A.

18 Avenue Dutartre, 78150 LeChesnay, France
Tel: +33 (1) 3923 2222; FAX: +33 (1) 3923 2225

Racal Systems Elettronica s.r.l.

Strada 2-Palazzo C4, 20090 Milanofiori Assago, Milan, Italy
Tel: +39 (0)2 5750 1796; FAX: +39 (0)2 5750 1828

Racal Elektronik System GmbH.

Technologiepark Bergisch Gladbach, Friedrich-Ebert-Strasse, D-51429 Bergisch Gladbach, Germany
Tel.: +49 2204 8442 00; FAX: +49 2204 8442 19

Racal Australia Pty. Ltd.

3 Powells Road, Brookvale, NSW 2100, Australia
Tel: +612 9936 7000, FAX: +612 9936 7036

Racal Electronics Pte. Ltd.

26 Ayer Rajah Crescent, 04-06/07 Ayer Rajah Industrial Estate, Singapore 0513.
Tel: +65 7792200, FAX: +65 7785400

Racal Instruments, Ltd.

Unit 5, 25F., Mega Trade Center, No 1, Mei Wan Road, Tsuen Wan, Hong Kong, PRC
Tel: +852 2405 5500, FAX: +852 2416 4335

<http://www.racalstruments.com>

RACAL

PUBLICATION DATE: July 25,2000

Copyright 2000 by Racal Instruments, Inc. Printed in the United States of America. All rights reserved.
This book or parts thereof may not be reproduced in any form without written permission of the publisher.

WARRANTY STATEMENT

All Racal Instruments, Inc. products are designed and manufactured to exacting standards and in full conformance to Racal's ISO 9001 procedures.

For the specific terms of your standard warranty, or optional extended warranty or service agreement, contact your Racal customer service advisor. Please have the following information available to facilitate service.

1. Product serial number
2. Product model number
3. Your company and contact information

You may contact your customer service advisor by:

E-Mail:	Helpdesk@racalstruments.com	
Telephone:	+1 800 722 3262	(USA)
	+44(0) 8706 080134	(UK)
	+852 2405 5500	(Hong Kong)
Fax:	+1 949 859 7309	(USA)
	+44(0) 1628 662017	(UK)
	+852 2416 4335	(Hong Kong)

RETURN of PRODUCT

Authorization is required from Racal Instruments before you send us your product for service or calibration. Call your nearest Racal Instruments support facility. A list is located on the last page of this manual. If you are unsure where to call, contact Racal Instruments, Inc. Customer Support Department in Irvine, California, USA at 1-800-722-3262 or 1-949-859-8999 or via fax at 1-949-859-7139. We can be reached at: helpdesk@racalstruments.com.

PROPRIETARY NOTICE

This document and the technical data herein disclosed, are proprietary to Racal Instruments, and shall not, without express written permission of Racal Instruments, be used, in whole or in part to solicit quotations from a competitive source or used for manufacture by anyone other than Racal Instruments. The information herein has been developed at private expense, and may only be used for operation and maintenance reference purposes or for purposes of engineering evaluation and incorporation into technical specifications and other documents which specify procurement of products from Racal Instruments.

FOR YOUR SAFETY

Before undertaking any troubleshooting, maintenance or exploratory procedure, read carefully the **WARNINGS** and **CAUTION** notices.

This equipment contains voltage hazardous to human life and safety, and is capable of inflicting personal injury.

If this instrument is to be powered from the AC line (mains) through an autotransformer, ensure the common connector is connected to the neutral (earth pole) of the power supply.

Before operating the unit, ensure the conductor (green wire) is connected to the ground (earth) conductor of the power outlet. Do not use a two-conductor extension cord or a three-prong/two-prong adapter. This will defeat the protective feature of the third conductor in the power cord.

Maintenance and calibration procedures sometimes call for operation of the unit with power applied and protective covers removed. Read the procedures and heed warnings to avoid “live” circuit points.

Before operating this instrument:

1. Ensure the instrument is configured to operate on the voltage at the power source. See Installation Section.
2. Ensure the proper fuse is in place for the power source to operate.
3. Ensure all other devices connected to or in proximity to this instrument are properly grounded or connected to the protective third-wire earth ground.

If the instrument:

- fails to operate satisfactorily
- shows visible damage
- has been stored under unfavorable conditions
- has sustained stress

Do not operate until performance is checked by qualified personnel.

TABLE OF CONTENTS

MODEL 3152 PRECISION PLL SYNTHESIZER

Getting Started

What's In this Chapter	1-1
Introduction	1-1
Options	1-2
Manual Changes	1-3
Safety Considerations	1-3
Supplied Accessories	1-4
Specifications	1-4
Functional Description	1-4
Input and Output Connectors	1-4
Main Output	1-4
SYNC Output	1-4
External Clock Input	1-4
PM Input	1-5
Trigger Input	1-5
Operating Modes	1-5
Continuous Mode	1-5
Triggered Mode	1-5
Burst Mode	1-6
Gated Mode	1-6
Output Type	1-6
Standard Waveforms	1-6
Arbitrary Waveforms	1-6
Sequenced Waveforms	1-7
Output State	1-8
Backplane Synchronization	1-9
Front Panel PLL	1-9
Frequency Counter	1-9
Phase Modulation	1-9
Filter	1-9
Front Panel Indicators	1-9
Programming The Model 3152	1-10

Configuring The Instrument

Installation Overview	2-1
Unpacking and Initial Inspection	2-1
Safety Precautions	2-1
Performance Checks	2-2
Grounding Requirements	2-2
Long Term Storage or Repackaging For Shipment	2-2
Preparation For Use	2-3
Logical Address Selection	2-3
Installation	2-5

Using The Instrument

Overview	3-1
Output Termination	3-1
Input/Output Protection	3-1
Power On/Reset Defaults	3-1
What To Do Now	3-2
Using the APPLY Command	3-3
Output Configuration Commands	3-7
Selecting An Output Function Type	3-7
Selecting a Standard Function Shape	3-8
Changing the Frequency and Sample Clock	3-8
Selecting the Sample Clock Source	3-9
Programming the Output Amplitude and Offset	3-9
Selecting the Filter Type	3-10
Activating the Backplane ECLTRG and TTLTRG	3-10
Assigning the Validating Source For TTLTRG	3-12
Enabling the Main Output	3-12
Enabling the SYNC Output	3-13
Assigning the Source For the SYNC Output	3-13
Selecting the SYNC Position	3-14
Using the Built-In Standard Waveforms	3-14
Selecting An Operating Mode	3-17
Triggered Mode	3-17
Gated Mode	3-18
Burst Mode	3-19
Selecting the Trigger Source	3-19
Using the Internal Trigger Generator	3-20
Selecting the Trigger Slope	3-20
Selecting the Trigger Level	3-21
Using the Soft Trigger	3-21
Generating Arbitrary Waveforms	3-21
What Are Arbitrary Waveforms	3-21
Arbitrary Memory Management	3-22
Memory Management Commands	3-22
Loading Arbitrary Waveforms	3-23
Reversing Byte Order	3-25
Using Shared Memory	3-25
Sequence	3-27
Generating Sequenced Waveforms	3-27
What Are Sequenced Waveforms	3-27
Sequence Commands	3-29
Triggered Sequence Advance	3-30
Triggered Sequence Advance Commands	3-31
Backplane Inter-Module Synchronization	3-31
Front-Panel Phase Synchronization	3-33
PLL Commands	3-33
Using the Frequency Counter	3-34
Using the Phase Modulation Input	3-35
Amplitude Modulation Commands	3-35
System-Related Commands	3-36

SCPI Command Reference

What's In This Chapter	4-1
Introduction To SCPI Language	4-1
Command Format	4-2
Command Separator	4-2
The MIN and MAX Parameters	4-3
Querying Parameter Setting	4-3
Query Response Format	4-3
SCPI Command Terminator	4-3
IEEE-STD-488.2 Common Commands	4-4
SCPI Parameter Type	4-4
Numeric Parameters	4-4
Discrete Parameter	4-4
Boolean Parameter	4-4
Arbitrary Block Parameters	4-5
SCPI Command Summary	4-5
Output Configuration Command Summary	4-8
Standard Waveform Command Summary	4-10
Arbitrary Waveform, Sequence, and Shared Memory Command Summary	4-11
Modulation Command Summary	4-11
Trigger Command Summary	4-12
Backplane Inter-Module Phase Synchronization Command Summary	4-12
Front-Panel PLL Command Summary	4-12
System-Related Command Summary	4-13
IEEE-STD-488.2 Common Commands and Queries	4-13
The SCPI Status Registers	4-15
The Status Byte Register (STB)	4-18
Reading the Status Byte Register	4-18
Clearing the Status Byte Register	4-18
Service Request Enable Register (SRE)	4-19
Standard Event Status Register (ESR)	4-19
Standard Event Status Enable Register (ESE)	4-20
Error Messages	4-21
Device-Specific Commands	4-22

Maintenance and Performance Checks

What's In This Chapter	5-1
Disassembly Instructions	5-1
Special Handling of Static Sensitive Devices	5-2
Cleaning	5-2
Repair and Replacement	5-2
Performance Checks	5-3
Environmental Conditions	5-3
Warm-Up Period	5-3
Initial Instrument Setting	5-3
Recommended Test Equipment	5-4
Performance Check Procedures	5-4
Frequency Accuracy	5-4
Amplitude Accuracy	5-5
DC Offset Characteristics	5-5
Squarewave Characteristics	5-6
Sine Characteristics	5-7
Sine Flatness	5-8

Trig, Gate and Burst Characteristics	5-8
PLL Characteristics	5-10
Adjustments	5-11
Environmental Conditions	5-11
Warm-up Period	5-12
Recommended Test Equipment	5-12
Adjustment Procedures	5-12
Pulse Response Adjustment	5-13
Amplitude Adjustment	5-13
Offset Adjustment	5-14
VCO Adjustment	5-14
PLL Adjustment	5-15
Troubleshooting	5-15
Recommended Test Equipment	5-16
Power-Up Tests	5-16
Self-Test	5-16
Main Board Circuit Checkout	5-16
Power Supply Checkout	5-16
CPU and VXI ASIC Checkout	5-17
Output Amplifier and Amplitude Control Checkout	5-18
Clock Synthesizer Checkout	5-19
Sequence Generator Checkout	5-20
PLL Checkout	5-21
Engine Board Circuit Checkout	5-22
Engine Board Checkout	5-22

APPENDIX A

Specifications	A-1
----------------------	-----

FIGURES

1-1	Segment 1 - Sin(x)/xWaveform	1-7
1-2	Segment 2 - Sine Waveform	1-7
1-3	Segment 3 - Pulse Waveform	1-8
1-4	Sequenced Waveforms	1-8
2-1	Set The Logical Address	2-4
3-1	Definite Length Arbitrary Block Data Format	3-24
3-2	12-Bit Waveform Data Format	3-24
3-3	Sin(x)/x Waveform Loaded Into Segment 1	3-27
3-4	Sine Waveform Loaded Into Segment 2	3-28
3-5	Pulse Waveform Loaded Into Segment 3	3-28
3-6	Sequenced Waveforms - Continuous Advance Mode	3-29
3-7	Sequenced Waveforms - Triggered Advance Mode	3-30
4-1	SCPI Status Registers	4-17

TABLES

3-1	Default Conditions After Power On, RESet or *RST	3-2
3-2	Amplitude and Offset Ranges	3-3
4-1	VXIbus Model 3152 SCPI Commands List Summary	4-6
5-1	CPU and VXI Interface Checkout Procedure	5-17
5-2	Output Amplifier and Amplitude Control Checkout Procedure	5-18
5-3	Clock Synthesizer Checkout Procedure	5-19
5-4	Sequence Generator Checkout Procedure	5-20
5-5	Burst Generator Checks	5-21
5-6	PPL Checkout Procedure	5-21
5-7a	Engine Board Checkout Procedure - #1	5-22
5-7b	Engine Board Checkout Procedure - #2	5-23
5-7c	Engine Board Checkout Procedure - #3	5-23

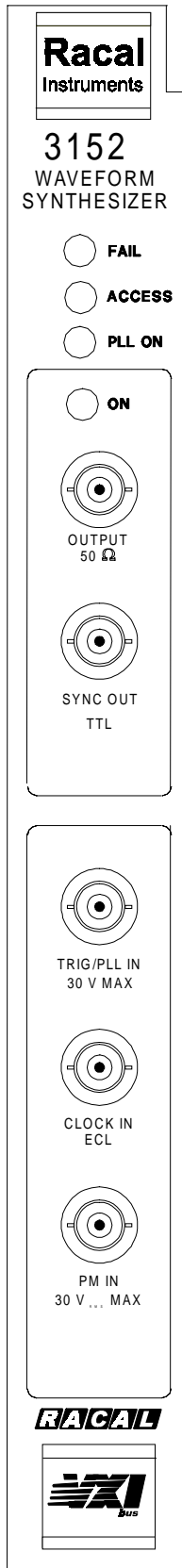

3152 Front Panel

Getting Started

What's In This Chapter

This chapter contains a general description of the VXIbus Model 3152 Waveform Synthesizer and an overall functional description of the instrument. It lists and describes various options available for this model. It also describes the Model 3152 front panel connectors and indicators.

This manual provides a complete description of all features and options available with the Model 3152; however, some items described in the following paragraphs may not be installed in your instrument.

Introduction

A detailed functional description is given following the general description of the features, functions, and options available with the Model 3152.

The Model 3152 is a VXIbus, single slot C-size Synthesized Waveform Generator. It is a high performance waveform synthesizer that combines two powerful instruments in one small package; a function generator and an arbitrary waveform generator. The instrument provides a variety of standard waveforms to be used as test stimuli for different electronic devices. The Model 3152 is also capable of generating arbitrary waveforms with sampling rates to 100 MHz at 12 bits of vertical resolution.

Despite its small size, the Model 3152 offer many features and functions such as *VXIplug&play* compatibility, backplane phase synchronization, front-panel PLL, counted burst, internal trigger-generator, and more. The instrument generates high quality, high accuracy waveforms throughout the specified frequency range, amplitude span, and operating temperature. The Model 3152 generates sine waveforms with a spectral purity that can only be matched by much more expensive bench type synthesizers.

The Model 3152 generates standard waveforms at frequencies ranging from 100 μ Hz to 50 MHz. Frequency may be set with 7 digit resolution. Accuracy and stability of the output frequency depend on the reference clock. As a default, CLK10 is used as the reference clock. The typical accuracy and stability of CLK10 is 100 ppm. An optional internal TCXO circuit provides 1 ppm accuracy and stability. When the optional TCXO is installed, the output frequency can be programmed with a full seven digits of resolution.

Arbitrary waveforms are generated with clock rates ranging from 100 mHz to 100 MHz. Output amplitude may be programmed within the range of 20 mV to 32 Vp-p into an open circuit, and 10 mV to 16V into 50 Ω . Amplitude and offsets are programmed with 4 digit resolution.

Besides its normal continuous mode, the Model 3152 offers a variety of interrupted modes. The output waveform may be gated, triggered, or may generate a counted burst of waveforms. A built-in trigger generator with a programmable period can replace an external trigger.

The Model 3152 generates arbitrary waveforms with 12 bits of resolution. There are nine standard waveforms which are memory-resident. Other waveforms may be generated, either manually or downloaded from the controller to the instrument using shared memory or standard data bus transfer. Waveforms may also be generated using the WaveCAD program.

The Model 3152 waveform synthesizer is a digital instrument. Besides its standard waveforms, any waveform it generates must first be loaded into the arbitrary waveform memory. The arbitrary waveform memory is a bank of 8-bit words. Each word represents a point on the waveform. Each word has a horizontal address that can range from 0 to 64536 (optionally 523288) and a vertical address that can range from -2047 to +2048 (12 bits). Using a high speed clocking circuit, the digital contents of the arbitrary waveform memory are extracted and routed to the D/A converter. The D/A converts the digital data to an analog signal, and the output amplifier completes the task by amplifying or attenuating the signal at the output connector.

The Model 3152 is fully programmable using SCPI commands and syntax. There are two ways to program the Model 3152, the first being low level programming of each individual parameter. The second alternative is to use the *VXIplug&play* soft front panel for high level programming. The *VXIplug&play* soft front panel simulates a mechanical front panel with the necessary push buttons, displays and dials to operate the Model 3152 as a bench-top instrument. The Model 3152 will not operate without being programmed. Therefore, it is recommended that the user become familiar with its basic features, functions and programming concepts as described in this and the following chapters.

Options

A number of options are offered with the Model 3152. Compare the option number with the number that is printed on the instrument to verify which of the options is installed in your instrument. Note that all Model 3152 options are installed in the factory. Contact your nearest Racal representative if the number printed on the case does not reflect the correct version ordered. The list of available Model 3152 options is given below:

1. 407510-001 - Model 3152 - 100MS/s Waveform Synthesizer, w/64K RAM
2. 407510-002 - Model 3152 - 100MS/s Waveform Synthesizer, w/256K RAM
3. 407510-011 - Model 3152 - 100MS/s Waveform Synthesizer, w/512K RAM
4. 407510-021 - Model 3152 - 100MS/s Waveform Synthesizer, w/64K RAM, 1PPM

Getting Started 1-2

5. 407510-012 - Model 3152 - 100MS/s Waveform Synthesizer, w/256K RAM, 1PPM
6. 407510-002 - Model 3152 - 100MS/s Waveform Synthesizer, w/512K RAM, 1PPM
7. 407510-012 - Model 3152 - 100MS/s Waveform Synthesizer, w/ 64K RAM, 100PPM
8. 407510-022 - Model 3152 - 100MS/s Waveform Synthesizer, w/256K RAM, 100PPM
9. 407510-021 - Model 3152 - 100MS/s Waveform Synthesizer, w/512K RAM, 100PPM

The 64K RAM option designates the memory size supplied with the Model 3152. The standard memory size is 64K (65536 words). With the standard memory size, 64536 point waveforms can be programmed because 1K is allocated for standard waveforms.

The 256 suffix designates instruments supplied with 256K memory expansion. With the 256K expansion, 261144 point waveforms can be programmed.

The 512K RAM option designates instruments supplied with 512K memory expansion. With the 512K expansion, 523288 point waveforms can be programmed.

1ppm and 100ppm denote different accuracy and stability grades of the internal 10 MHz reference clock. Normally, VXIbus modules receive their clock reference from VXIbus CLK10. There are applications that require complete separation from VXIbus clocks. The crystal oscillator (100ppm) and TCXO (1ppm) options, when installed, provide the required separation.

Manual Changes

Technical corrections to this manual (if any) are noted on the pages themselves, with change dates at the bottom of the page.

Safety Considerations

The Model 3152 has been manufactured according to international safety standards. The instrument meets VDE 0411/03.81 and UL 1244 standards for safety of commercial electronic measuring and test equipment for instruments with an exposed metal chassis that is directly connected to earth via the chassis power supply cable.

WARNING Do not remove instrument covers when operating or when the chassis power cord is connected to the mains.

Any adjustment, maintenance and repair of an opened, powered-on instrument should be avoided as much as possible, but when necessary, should be carried out only by a skilled person who is aware of the hazard involved.

Revised 4/18/00

Getting Started 1-3

Supplied Accessories

The Model 3152 is supplied with an Instruction Manual. The manual includes disks with VXI *plug&play* soft front panel and drivers along with WaveCAD for Windows. A Service Manual is available upon request.

Specifications

Instrument specifications are listed in **Appendix A**. These specifications are the performance standards or limits against which the instrument is tested. Specifications apply under the following conditions: output terminated into 50Ω after 30 minutes of warm up time, and within a temperature range of 20°C to 30°C. Specifications outside this range are degraded by 0.1% per °C.

Functional Description

A detailed functional description is given in the following paragraphs. The description is divided into logical groups: input and output connectors, operating modes, output type, output state, synchronization, filters and front panel indicators.

Input and Output Connectors

The Model 3152 has 5 BNC connectors on its front panel: main output, SYNC output, phase modulation input, reference clock output and the trigger input.

Main Output

The main output connector outputs standard, user, and sequenced waveforms. Output impedance of this output is 50Ω, that is, the cable which is connected to this input should be terminated with a 50Ω resistance. Output amplitude accuracy is calibrated when connected to a 50Ω load. If the output is connected to a different load resistance, determine the actual amplitude from the resistance ratio of the internal 50Ω to the load impedance. The output amplitude is doubled when the output impedance is above 1 MΩ.

SYNC Output

The SYNC Output generates a single TTL pulse for synchronizing other instruments (i.e., an oscilloscope) to the output waveform. The SYNC signal always appears at a fixed point relative to the waveform. The SYNC output generates a single point pulse for standard and arbitrary waveforms. The location of the SYNC signal along the waveform is programmable from point 2 to the last point on the waveform.

External Clock Input

The External Clock Input is available for those applications required to run the complete system off the same clock. Normally, this input is disabled. When enabled under program control the clock at this input replaces the internal clock generator and the output waveform will begin generating waveforms with clock rates that are present at the external clock input. Do not confuse the clock frequency with the frequency of the waveform. The actual frequency of the output waveform depends on the number of points that are allocated for the waveform. For example, if the external clock is 10 MHz and the number of points that were assigned to the active segment is 1000, the output frequency will be 10 KHz (10 MHz divided by the number of points). The external clock input accepts fixed level ECL signals within the range of DC to 100 MHz.

PM Input

The PM Input accepts signals that phase modulates the main output frequency. The phase modulation function operates in conjunction with the PLL function. The PM input is active at all times. Therefore, unless you intend to use this function, do not connect any cables to this input during normal operation of the Model 3152.

Getting Started 1-4

Trigger Input

The Trigger Input accepts signals that stimulate the Model 3152 to output waveforms. The trigger input is inactive when the instrument is in continuous operating mode. When placed in trigger, gated or burst mode, the trigger input is made active and waits for the right condition to trigger the instrument. In trigger and burst modes, the trigger input is edge sensitive, i.e., it senses transitions from high to low or from low to high to trigger the Model 3152. The direction of the transition is programmable. In PLL mode, the trigger input is used as phase reference input.

In gated mode, the trigger input is level sensitive, i.e., the Model 3152 is gated when the level is high and idle when the level is low. Level sensitivity may be programmed for the trigger input.

Operating Modes

There are a number of operating modes that the Model 3152 can be programmed to operate in: continuous mode, triggered mode, gated mode and burst mode. These operating modes are described below.

Continuous Mode

In continuous mode, the selected waveform is output continuously at the selected frequency, amplitude and offset.

Triggered Mode

In triggered mode, the Model 3152 circuits are armed to generate one output waveform. The trigger circuit is sensitive to transitions at the trigger input. Select between positive or negative transitions to trigger the instrument. You may also program the trigger level to the desired threshold level on the external signal. When triggered, the synthesizer outputs the waveform and remains idle at the last point of the waveform. The Model 3152 can be armed to receive a trigger signal from the front panel BNC connector, a VXIbus backplane TTLTRG<n> or from an internal, programmable trigger generator.

The trigger signal, whether it comes from the front panel or from the VXIbus, has to pass through circuitry. These circuits cause a small delay known as system delay. System delay cannot be eliminated completely. It is, however, minimized in the Model 3152 to approximately 200ns maximum. System delay is a factor that must be considered when applying a trigger signal. It defines how long it will take from a valid trigger edge to the moment that the output reacts.

While system delay cannot be controlled, the Model 3152 offers a controllable trigger delay parameter. When utilized, delay from a trigger signal to output waveform may be programmed from 0 clocks to one million clocks. This delay is additional to the system delay.

Burst Mode

The burst mode is an extension of the triggered mode where the Model 3152 can be armed to output a counted number of waveforms following a triggered signal. Like trigger mode, burst can be triggered from a front panel BNC connector, a VXIbus backplane TTLTRG<n> or from an internal, programmable trigger generator.

Gated Mode

In gated mode, the Model 3152 circuits are armed to generate output waveforms as long as a gating signal is true. Unlike the triggered mode, the gated mode is level sensitive. When the gating signal goes false, the waveform at the output connector is first completed and the output goes to an idle state. The stop amplitude level, after a gating signal, is the last point on the waveform.

Output Type

The Model 3152 can output three types of waveforms: standard waveforms, arbitrary waveforms and sequenced waveforms. The three types of waveforms are described in the following.

Standard Waveforms

The Model 3152 generates waveforms from a memory that has to be loaded before the instrument can generate waveforms. There are 64K points of memory standard, 256K and 512K points available as an option. 1K points from this memory are allocated for standard waveforms. Waveforms are loaded into this part of the memory each time a standard function is selected.

The Model 3152 can be programmed to output nine different standard waveforms: sine wave, triangular wave, square wave, pulse, ramp, sinc (sine(x)/x), gaussian pulse, exponential pulse and DC. There are certain parameters that are associated with each standard function. These parameters can be programmed to generate modified standard waveforms.

Arbitrary Waveforms

The arbitrary waveform memory is capable of storing one or more user waveforms. There are 64536 points (523288 optional) that can be allocated to one waveform that has this length. If there is no need to use the complete memory, it can be divided into smaller segments, variable in size. Load each segment with a different waveform and program the Model 3152 to output the required waveform for a specific test. Loading data to arbitrary waveform memory can be a time-consuming task, especially if the complete 512K is loaded in one shot. The Model 3152 utilizes the VXIbus shared memory concept that speeds data transfer from and to the host computer. In this mode, the memory bank is disconnected from the CPU circuit and its bus is accessible from the VXIbus for direct memory access by the host computer.

Sequenced Waveforms

The Model 3152 employs a sophisticated circuit that allows dividing the memory into smaller segments, linking of the segments in user-defined order, and repeating of each linked segment up to one million times. The sequence circuit is useful for generating long waveforms with repeated sections. The repeated waveform has to be programmed once and the repeater will loop on this segment as many times as selected. When in sequenced mode, there is no loss of time between linked or looped segments. **Figure 1-4** shows an example of a sequenced waveform. Assume the waveforms in **Figures 1-1** through **1-3** were placed in segments 1 through 3.

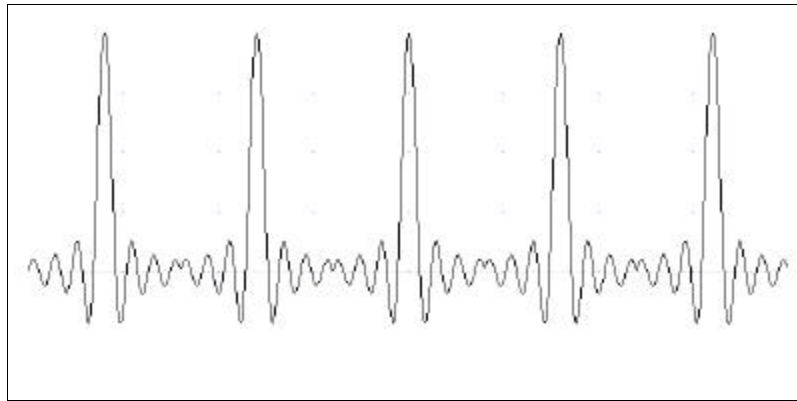
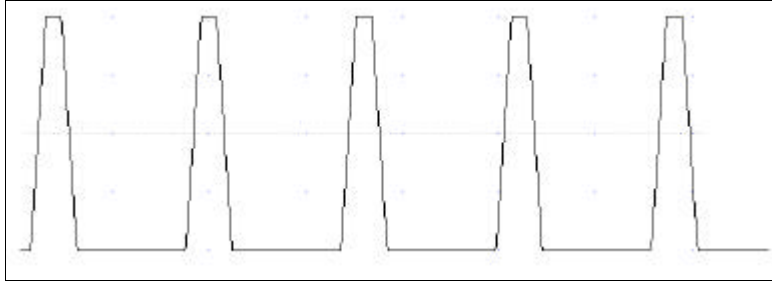

Figure 1-1
Segment 1 -
Sin(x)/x
Waveform

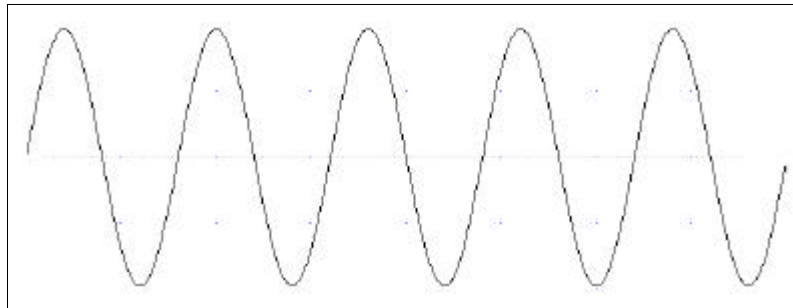
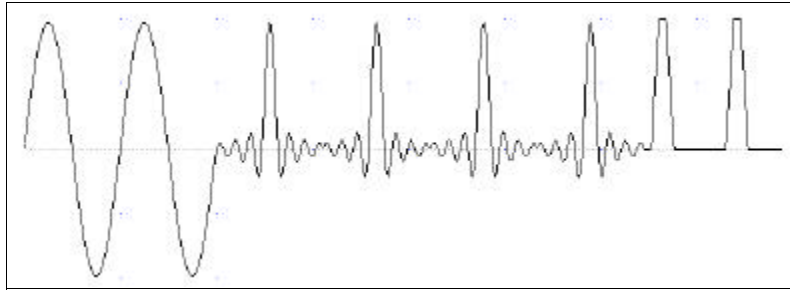

Figure 1-2
Segment 2 -
Sine Waveform

**Figure 1-3
Segment 3 -
Pulse
Waveform**



The following sequence was made of segment 2 repeated twice, segment 1 repeated four times and segment 3 repeated twice.

Figure 1-4 Sequenced Waveforms

Output State

The main output can be turned on or off. The internal circuit is disconnected from the output BNC connector by a mechanical switch under program control (relay). This feature is useful for connecting the Model 3152 main output, along with other instruments, to an analog bus. For safety reasons, after power on, the main output is always off.

Backplane Synchronization

Multiple Model 3152s may be synchronized and operated together inside one VXIbus chassis. With one instrument configured as master and the rest of the instruments configured as slaves, the instruments are phase-locked to the start phase on the master module. The slave modules may be configured to have phase offsets within the range of 0° to 360° . There is no need to install multiple Model 3152 modules in adjacent slots to be able to phase synchronize modules.

Front-Panel PLL

Model 3152 may be phase locked to an external reference and phase shifted from the start phase of the external reference from -180° to $+180^\circ$. The reference signal is applied to a front-panel input BNC. In this way, the same reference can be applied to multiple modules to generate multi-phase signal patterns. The reference signal for the PLL function is applied to the TRIG IN. It shares the same characteristics as the trigger input, programmable trigger level and programmable slope. When placed in this mode, the model 3152 scans the TRIG IN connector for a valid signal. Once sensed, the model 3152 measures its frequency and centers its lock-in range around this frequency. The model 3152 then locks automatically on the frequency of the external signal. There is no need for manual initiation or operator intervention for locking the model 3152 to an external reference. The PLL range is 500 Hz to 10 MHz.

Frequency Counter

The Model 3152 uses an autoranging counter circuit to measure frequencies of reference signals at the trigger input. This built-in counter is made available for you in PLL mode. Thus, you can use the 3152 as a frequency counter provided that the signal at the trigger input is valid and the PLL ON LED illuminates. Frequencies are measured from 500 Hz to 10 MHz. External frequency query returns four digits with a decimal point and suffix multiplier.

Phase Modulation

When the Model 3152 is placed in PLL mode, there are two ways to control the phase offset. The first option is to modify the phase offset setting using SCPI commands. This method is extremely accurate while permitting phase offset adjustments with 0.01° increments. The PM IN provides another option for changing phase offsets. Applying voltage to this input changes the start phase of the synthesizer continuously, depending on the voltage level at the phase modulation input. The applied voltage range is DC to 10 kHz, depending on the lock frequency and the number of waveform samples.

Filter

Three filters are built into the Model 3152, each having a different cutoff frequency and rise time properties. These filters are available for use in various applications, depending on the specific requirement. The 20 MHz Gaussian filter has a gaussian response which smooths fast transitions and eliminates ringing and aberrations. The 25 MHz and the 50 MHz filters are elliptical with a very sharp cutoff frequency. They are useful for removing the staircase effect from waveforms that are generated with high frequency clock rates.

Front Panel Indicators

There are three LEDs on the front panel. The FAIL LED (Red) illuminates at power-up until the Model 3152 has passed its self-test. If the Model 3152 self-test fails, the FAIL LED remains illuminated.

Programming The Model 3152

The FAIL LED may be illuminated during normal operation if the Model 3152 stops communication.

The ACCESS LED (Amber) illuminates each time a command has been received by the Model 3152. This light remains on during shared memory data transfer.

The PLL ON LED is off during normal operation. In PLL mode, the PLL ON illuminates when a valid signal is available at the trigger input and lock frequency is available at the main output connector.

When the output state is on, the OUTPUT LED (Green) light illuminates. It goes off when the output state is changed to off.

The Model 3152 has no controls on the front panel. Instrument functions, parameters, and modes can only be accessed through VXIbus commands. There are a number of ways to “talk” to the instrument. They all require that an appropriate software driver be installed in the Resource Manager (slot 0). The rest is a matter of practice and knowledge of the language in use. There are other system considerations like address selection that have to be settled before programming the instrument. These topics are discussed in later chapters.

Low level programming of the Model 3152 is done using SCPI (Standard Commands for Programmable Instruments) language via VXIbus Word Serial Protocol. Programming aspects are covered in **Chapters 3 and 4**.

High level drivers like *VXIplug&play* and *WaveCAD* are beyond the scope of this manual. Contact your Racal representative for more information about high level drivers for the Model 3152.

Configuring The Instrument

Installation Overview

This chapter contains information and instructions necessary to prepare the Model 3152 for operation. Details are provided for initial inspection, grounding safety requirements, repacking instructions for storage or shipment, logical address selection and installation information.

Unpacking and Initial Inspection

Unpacking and handling of the synthesizer requires only normal precautions and procedures applicable to handling of sensitive electronic equipment. The contents of all shipping containers should be checked for included accessories and certified against the packing slip to determine that the shipment is complete

Safety Precautions

The following safety precautions should be observed before using this product and associated computer. Although some instruments and accessories would normally be used with non-hazardous voltages, there are situations where hazardous conditions may be present.

This product is intended for use by qualified personnel who recognize shock hazards and are familiar with the safety precautions required to avoid possible injury. Read the operating information carefully before using the product.

Exercise extreme caution when a shock hazard is present. Lethal voltage may be present on cables, connector jacks, or test fixtures. The American National Standard Institute (ANSI) states that a shock hazard exists when voltage levels greater than 30V RMS, 42.4V peak or 60 VDC are present.

WARNING For maximum safety, do not touch the product, test cables, or any other instrument parts while power is applied to the circuit under test. ALWAYS remove power from the entire test system before connecting cables or jumpers, installing or removing cards from the computer, or making internal changes such as changing the module address.

Do not touch any object that could provide a current path to the common side of the circuit under test or power line (earth) ground. Always keep your hands dry while handling the instrument.

When using test fixtures, keep the lid closed while power is applied to the device under test. Safe operation requires that the computer lid be closed at all times during operation. Carefully read the "Safety Precautions" instructions that are supplied with your computer.

Before performing any maintenance, disconnect the line cord and all test cables.

Maintenance should be performed by qualified service personnel

Performance Checks

The instrument has been inspected for mechanical and electrical performance before shipment from the factory. It is free of physical defects and in perfect electrical order. Check the instrument for damage in transit and perform the electrical procedures outlined in the section entitled **Unpacking and Initial Inspection**.

Grounding Requirements

To insure the safety of operating personnel, the U.S. O.S.H.A. (Occupational Safety and Health) requirement and good engineering practice mandate that the instrument panel and enclosure be "earth" grounded. Although BNC housings are isolated from the front panel, the metal part is connected to earth ground.

WARNING Do not make an attempt to float the output from ground as it may damage the Model 3152 and your equipment.

Long Term Storage or Repackaging For Shipment

If the instrument is to be stored for a long period of time or shipped immediately, proceed as directed below. If you have any questions, contact your local Racal Instruments Representative or the Racal Instruments Customer Service Department.

1. Repack the instrument using the wrappings, packing material and accessories originally shipped with the unit. If the original container is not available, purchase replacement materials.
2. Be sure the carton is well-sealed with strong tape or metal straps.
3. Mark the carton with the model and serial number. If it is to be shipped, show sending and return address on two sides of the box.

NOTE

If the instrument is to be shipped to Racal Instruments for calibration or repair, attach a tag to the instrument identifying the owner. Note the problem, symptoms, and service or repair desired. Record the model and serial number of the instrument. Show the work authorization order as well as the date and method of shipment. **ALWAYS OBTAIN A RETURN AUTHORIZATION NUMBER FROM THE FACTORY BEFORE SHIPPING THE INSTRUMENT TO RACAL INSTRUMENTS.**

Preparation For Use

Preparation for use includes removing the Model 3152 from the container box, selecting the required logical address and installing the module in a VXIbus chassis.

Logical Address Selection

The VXIbus Chassis Resource Manager identifies modules in the system by the module's address. VXIbus logical addresses can range from 0 to 255, however, addresses 1 to 254 **only** are reserved for VXIbus modules. Logical address 0 is reserved for the Resource Manager. Logical address 255 permits the Resource Manager to dynamically configure the module logical address.

To change the Model 3152's logical address, use the 8-position DIP switch accessible from the top side of the module near the rear end of the case (switch S1). Figure 2-1 shows the location of the logical address switch. The switches are marked with numbers 1 to 8. The Model 3152 uses binary values (2^0 to 2^7) to set the logical address using the active low address switch. A switch is active when its arm is placed in the ON position.

Racal Instruments ships the Model 3152 with logical address 2.

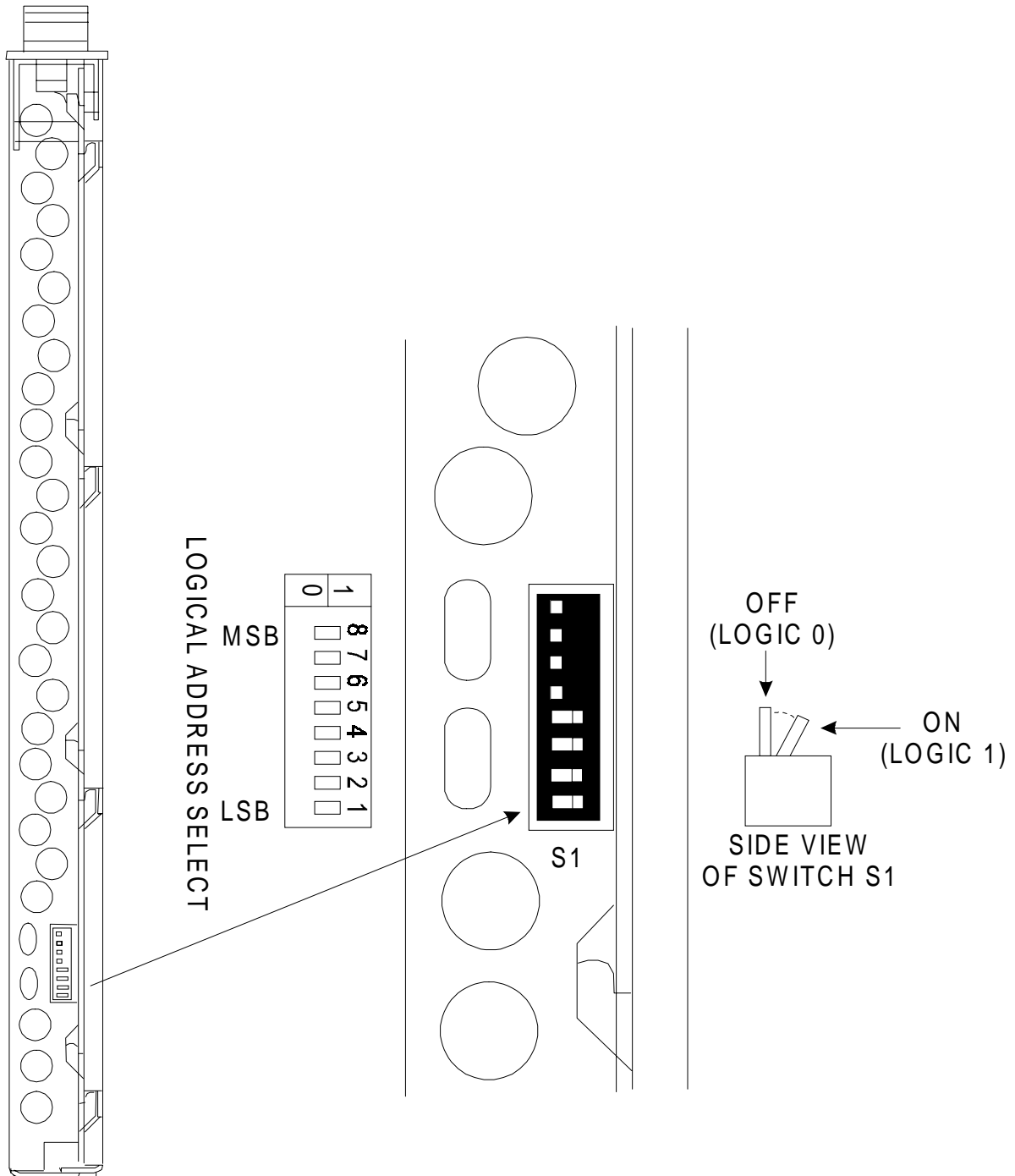

Figure 2-1 Set The Logical Address

Installation

The instrument can be installed in any slot except slot 0 in a VXIbus mainframe. When inserting the instrument into the mainframe, it should be gently rocked back and forth to seat the connectors into the backplane receptacle. The ejectors will be at right angles to the front panel when the instrument is properly seated into the backplane. Use two captive screws above and below the ejectors to secure the instrument into the chassis.

After installation, perform an initial checkout and operational verification.

This page was intentionally left blank

Using The Instrument

Overview

This chapter contains information about how to operate the Model 3152. Unlike bench-type instruments, the Model 3152 must be programmed to turn on functions, change parameters and configure various operating modes. The instrument can be programmed using a set of SCPI commands. A list of SCPI commands that control the Model 3152 is given in **Table 4-1**. The following paragraphs describe the various modes of operation and give examples on how to program the Model 3152.

Output Termination

During use, output connectors must be properly terminated to minimize signal reflection or power loss due to an impedance mismatch. Proper termination is also required for an accurate amplitude level at the main output connector. Use 50 Ω cables and terminate the main and SYNC cables with terminating resistors. Always place the 50 Ω termination at the far end of the cables.

Input/Output Protection

The Model 3152 provides protection for internal circuitry connected to input and output connectors. Refer to the specifications in **Appendix A** to determine the level of protection associated with each input or output connector.

Power On/Reset Defaults

At Power On or as a result of a software reset, the Model 3152 defaults to the conditions shown in **Table 3-1**. A complete list of all parameters and their default values is given in **Chapter 4**.

Use the following command to place the instrument in its default state:

```
RESet;
```

Using the IEEE-STD-488.2 common command *RST will have the same result.

Table 3-1 Default Conditions After Power On, RESet or *RST

Output State:	Off	Operating Mode:	Continuous
Filter State:	Off	Filter Type:	20 MHz
ECLTRG0-1:	Off	TTLTRG0-7:	Off
Output Trigger Source:	BIT	SYNC State:	Off
Std. Wave Frequency:	1 MHz	Arb. Wave Sample Clock:	1 MHz
Amplitude:	5 V	Offset:	0 V
Output Mode:	Std. Waveforms	Standard Waveform:	Sine
Inter-module Phase		Advance Mode:	Auto
Synchronization State:	Off	SYNC Out Position:	Point n-6
		SYNC Slate:	Off
Trigger Slope:	Positive	Internal Trigger Period:	100 μ Sec
Shared Memory State:	Off	Shared Memory Mode:	Read

What To Do Now

When writing low level code to operate the Model 3152, follow the instructions in this chapter to understand the meaning and response that each command generates. Examples contained in the following paragraphs show basic techniques on how to program output waveforms.

Example 1

The following example programs the Model 3152 to turn on the main output, generate a square waveform, program the frequency to 2 MHz, program the amplitude to 5 V and offset to 2.5 V.

/ Reset the Model 3152 to its default condition as listed in **Table 3-1.***/*

```
:RESet;
```

/ Change the output waveform to square. Note that there is no need to use the FUNC:MODE command as the default value after RESet is FIXed.*/*

```
:FUNCTion:SHAPE SQUare;
```

/ Change the frequency to 2 MHz.*/*

```
:FREQuency 2e6;
```

*/*Change the amplitude to 5 V and the offset to 2.5 V.*/*

```
:VOLTage 5;
```

```
:VOLTage: OFFSet 2.5;
```

There are three offset windows (± 8 V, ± 800 mV, ± 80 mV); the window selected is a function of the amplitude setting. **Table 3.2** shows the maximum offset available within each window.

Using The Instrument 3-2

Table 3-2 Amplitude and Offset Ranges

Amplitude	Window	Maximum Offset
≥1.6 V	±8 V	0 to ±7.19 V
≥160 mV	±800 mV	0 to 719 mV
≥10 mV	±80 mV	0 to 75 mV

To calculate the maximum offset available for a particular amplitude setting, use the following inequality:

$$\frac{V_{\text{amplitude}}}{2} + |V_{\text{offset}}| \leq 8 \text{ V} \quad | \quad 800 \text{ mV} \quad | \quad 80 \text{ mV}$$

Tip: If the desired amplitude/Offset setting cannot be obtained using Standard Waveforms, try generating it as an Arbitrary Waveform using WaveCAD.

/* Turn the main output on.*/

:OUTPut ON;

/*Turn the SYNC output on, if required.*/

:OUTPut:SYNC ON;

If the above commands are executed correctly, a square waveform will be seen on your oscilloscope.

Using the APPLy Command

The APPLy command provides a high level method of programming the synthesizer. Selection can be made for function, frequency, amplitude, offset and other parameters which are associated with the selected function. For example, the following statement outputs a 2 Vp-p square wave at 1 MHz with a 0 V offset and 10% duty cycle using APPLy:

APPL:SQU 1E6, 2, 0, 10

It is not necessary to enter every parameter with the APPLy command. If only the frequency and offset need to be changed, omit the other parameters while keeping the commas. The other parameters will be set to the power-up default values:

APPL:SQU 10E6,,1

Alternatively, if just the first parameters need to be changed, omit the commas. The other parameters will be set to the power-up default values:

```
APPL:SQU 4e6,2
```

Queries can also be made on all parameters associated with a standard function using the APPL: <function_shape>? query. For example, if the synthesizer was programmed using the above APPLy:SQU command, query the square wave parameters using the following query:

```
APPL:SQU?
```

The synthesizer returns a string that contains all the parameters associated with the square function similar to the following string: "1.000000e+6,2.000,0.000,50"

The command:

```
APPLy:SINusoid {<frequency>,<amplitude>,<offset>,<phase>,<power>}
```

programs the synthesizer to output a sine waveform with frequency, amplitude, offset, start phase and power parameters. Parameters are not optional if the above APPLy command is used. Include all other parameters in the command. The default settings for these functions are: 1 MHz, 5 Vp-p, 0 V, 0 and 1.

The command:

```
APPLy:TRiangle {<frequency>,<amplitude>,<offset>,<phase>,<power>}
```

programs the synthesizer to output a triangle waveform with frequency, amplitude, offset, start phase, and power parameters. The default settings for these functions are: 1 MHz, 5 Vp-p, 0 V, 0 and 1.

The command:

```
APPLy:SQUare {<frequency>,<amplitude>,<offset>,<duty_cycle>}
```

programs the synthesizer to output a square waveform with frequency, amplitude, offset and duty cycle parameters. The default settings for these functions are: 1 MHz, 5 Vp-p, 0 V, and 50%.

The command:

```
APPLy:PULSe{<frequency>,<amplitude>,<offset>,<delay>,<high_time>,<rise_time>,<fall_time>}
```

programs the synthesizer to output a pulse waveform with frequency, amplitude, offset, delay, rise time, high time and fall time parameters. The default settings for these functions are: 1 MHz, 5 Vp-p, 0 V, 0%, 10%, 10% and 10%.

The command:

```
APPLY:RAMP {<frequency>,<amplitude>,<offset>,  
<delay>,<rise_time>,<fall_time>}
```

programs the synthesizer to output a ramp waveform with frequency, amplitude, offset, delay, rise time, and fall time parameters. The default settings for these functions are: 1 MHz, 5 Vp-p, 0 V, 0%, 10% and 10%.

The command:

```
APPLY:SINC {<frequency>,<amplitude>,<offset>,  
<number_cycles>}
```

programs the synthesizer to output a sine(x)/x waveform with frequency, amplitude, offset, and number of cycles parameters. The default settings for these functions are: 1 MHz, 5 Vp-p, 0 V and 10.

The command:

```
APPLY:EXponential <frequency>,<amplitude>,<offset>,  
<exponent>}
```

programs the synthesizer to output an exponential waveform with frequency, amplitude, offset, and exponent parameters. The default settings for these functions are: 1 MHz, 5 Vp-p, 0 V and -10.

The command:

```
APPLY:GAUSSian {<frequency>,<amplitude>,<offset>,  
<exponent>}
```

programs the synthesizer to output a gaussian waveform with frequency, amplitude, offset, and exponent parameters. The default settings for these functions are: 1 MHz, 5 Vp-p, 0 V and 10.

The command:

```
APPLY:DC {<percent_amplitude>}
```

programs the synthesizer to output a DC level. The DC level is set as a percent of programmed amplitude. The default setting for this function is 100%.

The command:

```
APPLY:USER {<segment_number>,<sampling_clock>,  
<amplitude>,<offset>}
```

programs the synthesizer to output an arbitrary waveform. The specified segment number must be loaded with an arbitrary waveform before the synthesizer can execute this command successfully. This command lets you specify segment number, sampling clock rate, amplitude and offset. The default settings for these functions are: 1, 1 MHz, 5 Vp-p and 0 V.

Using The Instrument 3-5

The query:

```
APPLY:<function_shape>?
```

queries parameters associated with the specified function shape. Returns a string of values depending on the parameters that are available for the selected function shape.

The query:

```
APPLY?
```

queries parameters associated with the currently selected function shape and returns a string of values depending on the parameters available for the selected function shape. For example, if the synthesizer is programmed to output a ramp waveform, the APPLY? command returns: "1e+6, 5, 0, 0, 10, 10, 10".

Example 2

The following example programs the Model 3152 using the APPLY command. This example turns on the main output, generates a square waveform, programs frequency to 2 MHz, programs amplitude to 5 V and offset to 2.5 V. It also changes the square wave duty cycle parameter to 25%.

```
/* Reset the Model 3152 to its default condition as listed in Table 3-1.*/
```

```
:RESet;
```

```
/* Change the output waveform to square, frequency to 2 MHz, amplitude to 5 V, offset to 2.5 V and duty cycle to 25%. Note that there is no need to use the FUNC:MODE command because the default value after RESet is FIXed.*/
```

```
:APPLY:SQUare 2e6,5,2.5,25
```

```
/* Turn the main output on.*/
```

```
:OUTPut ON
```

```
/*Turn the SYNC output on, if required. */
```

```
:OUTPut:SYNC ON
```

If the above commands are executed correctly, a square waveform will be seen on your oscilloscope.

The output configuration commands control the output function, shape, frequency, amplitude, filter and state. Optional modes are omitted from these commands.

Output Configuration Commands

Selecting an Output Function Type

Use the following command to select the output function type:

```
FUNCTION:MODE {FIXed | USER | SEQUENCE}
```

When "FIXed" is selected, the synthesizer outputs the standard waveform currently selected by the FUNC:SHAP command. When "USER" is selected, the synthesizer outputs the arbitrary waveform currently selected by the TRAC:SEL command. When "SEQUENCE" is selected, the synthesizer outputs the sequence that is programmed using the SEQ:DEF command.

The query:

```
FUNCTION:MODE?
```

queries the output function type and returns either FIX, USER or SEQ.

Selecting a Standard Function Shape

Use the following command to select a standard output function:

```
FUNCTION:SHAPE {SINusoid | TRIangle | SQUare | PULSe | RAMP | SINC | EXPonential | GAUSSian | DC}
```

The selected waveform is output using the previously selected frequency, amplitude, offset, and other relevant settings. The standard waveform will be output only after the FUNC:MODE:FIX command is selected.

The query:

```
FUNCTION:SHAPE?
```

queries the standard function shape and returns either SIN, TRI, SQU, PULS, RAMP, SINC, EXP, GAUS or DC.

Changing the Frequency and Sample Clock

Use the following command to change the frequency for standard waveforms and sample clock for arbitrary waveforms:

```
FREQUENCY {<frequency> | MINimum | MAXimum}
```

MIN selects the lowest frequency allowed for the currently active function. MAX selects the highest frequency allowed for the currently active function. The default frequency setting is 1 MHz for all functions.

The query:

```
FREQUENCY?
```

queries the frequency setting for the standard function currently active and returns a value in hertz.

The command:

```
FREQuency:RASTer {<frequency> | MINimum |  
MAXimum}
```

sets the sample clock frequency for the user and sequenced functions. MIN selects the lowest frequency allowed for the currently active segment or sequence. MAX selects the highest frequency allowed for the currently active segment or sequence. The default sample clock frequency setting is 1 MHz for all functions.

Note that the output frequency depends on the number of points specified in the waveform. The output frequency can be computed using the following formula: Output Frequency = Sample Clock / Number of points in the active segment.

The query:

```
FREQuency:RASTer?
```

queries the sample clock frequency setting for the arbitrary segment or sequence currently active and returns a value in hertz.

Selecting the Sample Clock Source

Use the following command to select the source for the sample clock for the user and sequenced functions:

```
FREQuency:RASTer:SOURce {EXT | INT | ECLTRG0}
```

EXT selects an external clock source. The external source is applied to the front panel CLOCK IN connector. INT selects the internally synthesized clock synthesizer. ECLTRG0 selects a sample clock that is available on the backplane. Note that ECLTRG0 is always the active sample clock source when the Model 3152 is set to operate in phase synchronization mode.

The query:

```
FREQuency:RASTer:SOURce?
```

queries the sample clock source setting and returns EXT, INT or ECLT.

Programming the Output Amplitude and Offset

Use the following command to program the peak-to-peak amplitude for the generated waveform.

```
VOLTage {<amplitude>|MINimum|MAXimum}
```

MIN selects the smallest amplitude. MAX selects the largest amplitude. The default amplitude is 5.00 V (into 50Ω).

The query:

```
VOLTage?
```

queries the output amplitude for the currently selected function and returns a value in volts.

The command:

```
VOLTage:OFFSet <offset>
```

sets the offset for the currently active function. The default offset is 0 V.

The query:

```
VOLTage:OFFSet?
```

queries the output offset for the currently selected function and returns a value in volts.

Selecting the Filter Type

Before selecting the filter type, use the following command to activate the filter:

```
OUTPut:FILTer { OFF | ON }
```

ON enables the filter that has been selected with the OUTP:FILT:FREQ command. The default filter state setting is OFF.

The query:

```
OUTPut:FILTer?
```

queries the output filter state and returns "0" (OFF) or "1" (ON).

The command:

```
OUTPut:FILTer:FREQuency { <20MHz | 25MHz | 50MHz > }
```

sets the filter frequency for the currently active function. 20 MHz has a Gaussian response, and the 25 MHz and the 50 MHz filters have an Elliptical response. Note that the filters cannot be changed if the synthesizer is set to output sine waveform from its standard waveform library. The filters will be activated only after the OUTP:FILT ON command. The default filter setting is 20 MHz. Note also that 20 MHz, 25 MHz and 50 MHz designate filter types. These parameters should be programmed as switches, not as values. The filter type **cannot** be programmed using OUTP:FILT:FREQ 25e6 or OUTP:FILT:FREQ 50e6 Hz.

The query:

```
OUTPut:FILTer:FREQuency?
```

queries the currently selected filter setting and returns 20 MHz, 25 MHz or 50 MHz.

Activating the Backplane ECLTRG and TTLTRG

The Model 3152 can transmit and receive signals on the VXIbus ECLTRG and TTLTRG lines.

Use the following command to activate one of two backplane ECLTRG lines:

```
OUTPut:ECLTrg<n> { OFF | ON}
```

<n> designates the activated trigger line; 0 and 1 are available. ON enables the selected trigger line. The trigger source for this line can be selected with the TRIG:SOUR command. The default ECLTrg<n> state is OFF.

The query:

```
OUTPut:ECLTrg<n>?
```

queries the ECLTrg<n> state and returns "<n>,0" (OFF) or "<n>,1" (ON).

Turning on ECLTRG0 causes the module sample clock signal to be routed onto the VXI backplane. Other Model 3152s may be set up to receive this sample clock using the command `FREQ:RAST:SOURCE ECLTRG0` (See **Selecting the Sample Clock Source**). ECLTRG1 should not be enabled onto the backplane. Note that ECLTRG0 and ECLTRG1 are both used for Inter-Module Synchronization.

The TTLTRG lines can be used to transmit and receive trigger signals between the Model 3152 and other VXIbus modules.

Use the following command to activate one of eight backplane TTLTRG lines:

```
OUTPut:TTLTrg<n> { OFF | ON}
```

<n> designates the activated trigger line and 0 through 7 are available. ON enables the selected trigger line. The trigger source for this line can be selected with the TRIG:SOUR command. The default TTLTrg<n> state setting is OFF.

The query:

```
OUTPut:TTLTrg<n>?
```

queries the TTLTRG<n> state and returns "<n>,0" (OFF) or "<n>,1" (ON).

Assigning the Validating Source For TTLTRG

The TTLTRG signals, when enabled and placed on the backplane, can be asserted with signals coming from a number of sources. Use the following command to assign the signal source for the active TTLTRG line:

```
OUTPut:TRIGger:SOURce {BIT | LCOMplete |  
INTernal | EXTernal}
```

BIT Generates a trigger signal at any point in the waveform. The trigger position within the waveform can be programmed using the OUTPUT:SYNC:POS:POIN command. This command is used to set both the TRIGger point and the SYNC point.

LCOMplete Generates a trigger signal in SEQUENCE mode only once when the selected segment appears for the first time.

INTernal Generates a trigger signal at intervals set by the internal trigger generator .

EXTernal Generates a trigger signal every time a trigger is applied to the front panel TRIG IN connector.

The query:

```
OUTPut:TRIGger:SOURce?
```

queries the validating signal source for the backplane TTLTRG<n> lines and returns BIT, LCOM, INT or EXT.

Enabling the Main Output

For safety reasons, the main output default setting is OFF. Disable or enable the main output using the following command:

```
OUTPut {OFF | ON}
```

When the main output state is programmed to ON, the output connector is connected to the output amplifier through a 50Ω resistor. In the OFF position, the output connector is disconnected from the output amplifier by means of a mechanical relay. Ensure that voltage is **not** applied to the main output connector when the Model 3152 output state is programmed to ON.

The query:

```
OUTPut?
```

queries the state of the main output and returns "0" (OFF) or "1" (ON).

Enabling the SYNC Output

For safety reasons, the SYNC output default setting is OFF. Disable or enable the SYNC output using the following command:

```
OUTPut:SYNC {OFF | ON}
```

When the SYNC output state is programmed to ON, the SYNC output connector generates signals which are triggered by signals selected using the SYNC:SOUR command. In the OFF position, the SYNC connector has no output. It is connected electrically to the internal circuitry at all times. Ensure that voltage is **not** applied to the SYNC at any time. The default SYNC position is the 6th point from the end of the waveform. The position of the SYNC signal can be programmed using the OUTPUT:SYNC:POS:POIN command.

The query:

```
OUTPut:SYNC?
```

queries the state of the SYNC OUTPUT and returns "0" (OFF) or "1" (ON).

Assigning the Source For The SYNC Output

The SYNC output, when enabled, can be triggered by signals coming from a number of sources. Use the following command to select the source for validating the SYNC output:

```
OUTPut:SYNC:SOURce {BIT | LCOMplete | SSYNc | HCLock}
```

BIT Generates a sync signal every time the segment is output in User mode as well as in Sequenced mode. The sync position along the waveform can be programmed using the OUTPUT:SYNC:POS:POIN command. POIN is used to set both the TRIGGER point and the SYNC point. The BIT signal is recommended for use in continuous mode.

LCOMplete Generates a sync signal in SEQUENCE mode only once when the selected segment appears for the first time in the sequence. The identity of the segment can be programmed using the TRAC:SEL command. The sync position along the selected waveform can be programmed using the OUTPUT:SYNC:POS:POIN command. The LCOM signal is recommended for use in Sequence mode.

SSYNc Generates a sync signal at intervals that are synchronized with the internal clock generator. This option is useful to minimize jitter when using an oscilloscope. The SSYNc signal is recommended for use in Triggered mode.

HCLock Generates a trigger signal at intervals equal to half of the period of the sample clock. This option is useful for synchronizing two-point waveforms on an oscilloscope (sine and square waveforms above 10 MHz).

The query:

OUTPut:SYNC:SOURce?

queries the validating signal source for the SYNC output and returns BIT, LCOM, SSYN or HCL.

Selecting the SYNC Position

The SYNC output can be programmed to output the SYNC signal at any point along the output waveform. This function is available in USER or SEQ modes only. Use the following command to select the SYNC output position:

OUTPut:SYNC:POSition:POINt <value>

The SYNC position can be selected from point 0 to the last point of the active waveform. SYNC position has to be programmed for each segment. The default SYNC position is 6 points from the end of the segment.

The query:

OUTPut:SYNC:POSition:POINt?

queries the output SYNC position and returns an integer value.

Using the Built-In Standard Waveforms

The Standard Waveform commands control the various parameters of the active Standard Waveform. Standard waveform commands operate in a similar fashion for each of the Standard Waveforms. To simplify the description of this set of commands, only the standard waveform commands for the PULSe function are described. Use the same procedure to program parameters for the SINE, TRIangle, RAMP, SQUare, SINC, GAUSSian, EXPonential and DC waveforms.

The number of points used to define each Standard Waveform varies. For SINE and SQUare:

Freq \leq 200kHz	Points = 500
Freq < 200kHz	Points = $\frac{100\text{MHz}}{\text{Freq}}$

Freq > 10MHz	Points = 10
--------------	-------------

For RAMP, PULSE, GAUSSian and EXPonential:

Freq \leq 100kHz	Points = 1000
Freq > 100kHz	Points = $\frac{100\text{MHz}}{\text{Freq}}$

For TRIangle and SINC:

$$\begin{array}{ll} \text{Freq} \leq 200\text{kHz} & \text{Points} = 500 \\ \text{Freq} > 200\text{kHz} & \text{Points} = \frac{100\text{MHz}}{\text{Freq}} \end{array}$$

The equations used for generating EXPonential, GAUSsian and SINC functions are as follows:

For Positive EXPonential:

$$F(m) = -\frac{A}{2} + \frac{A}{2} \left[e^{\frac{m}{7.7t}} - 1 \right]$$

Where A = Amplitude
m = Current point (1..N)
N = Total number of points
t = Time constant set by user

For Negative EXPonential:

$$F(m) = A e^{-m^2/t^2} - \frac{A}{2}$$

For GAUSsian:

$$F(m) = A e^{-m^2/t^2} - \frac{A}{2}$$

For SINC:

$$F(m) = \frac{\text{Sine}\left(2.\pi.\frac{m}{R}\right).A}{2.\pi.\frac{m}{R}}$$

where $R = \frac{N}{\text{cyc}}$ (number of points per cycle)

cyc = Number of cycles of SINC

The standard waveform will be available at the output connector only after the FUNC:MODE FIX command has been executed. Select the FUNC:SHAP PULS command. Parameters for the PULSe function shape can now be modified and will cause an effect on the output waveform. Note that changes made to parameters for a specific function do not have any effect on other functions.

The command:

PULSe:DElAy <value>

sets the pulse delay in percent of the pulse period. For example, if the pulse period is 100 ms, 10% will delay the first transition of the pulse by 10 ms. Delay is measured from trigger to the first turning point.

The query:

PULSe:DElAy?

queries the pulse delay setting and returns a value in percent.

The command:

PULSe:TRANSition <value>

sets the pulse rise time in percent of the pulse period. For example, if the pulse period is 100 ms, 5% rise time equals 5 ms. Pulse rise time is measured between the two turning points of the first transition.

The query:

PULSe:TRANSition?

queries the pulse rise time setting and returns a value in percent.

The command:

PULSe:WIDTh <value>

sets the pulse width in percent of the pulse period. For example, if the pulse period is 100 ms, 20% pulse width equals 20 ms. Pulse width is measured between the two turning points on the top of the pulse.

The query:

PULSe:WIDTh?

queries the pulse width setting and returns a value in percent.

The command:

PULSe:TRANSition:TRAIling <value>

sets the pulse fall time in percent of the pulse period. For example, if the pulse period is 100 ms, 15% fall time equals 15 ms. Pulse fall time is measured between the two turning points of the second transition.

Selecting an Operating Mode

Triggered Mode

Gated Mode

The query:

```
PULSe:TRANSition:TRAILing?
```

queries the pulse fall time setting and returns a value in percent.

The Model 3152 offers four operating modes: Continuous, Triggered, Gated and Burst. The selected waveform is repeated continuously when the instrument is set to operate in Continuous mode. In this mode, the Model 3152 does not require a trigger source to stimulate its output cycles. The default operating mode of the instrument is continuous.

Triggered, Gated, and Burst modes require an external signal to initiate output cycles. Information on how to trigger, gate and output a burst of waveforms is given in the following paragraphs.

In Triggered mode, the output remains at a certain DC level as long as the TRIG IN signal from the front panel remains inactive. A TTL signal is used to stimulate the TRIG input. The synthesizer is sensitive to either the rising edge or the falling edge. Each time a transition at the trigger input occurs, the Model 3152 generates one complete output waveform. At the end of the output cycle, the output resumes position at a DC level equal to the last point of the waveform.

The Triggered mode operates on standard waveforms and arbitrary waveforms. Observe the limitations of the trigger signal as listed in the specification section of this manual. Note that for Standard Waveforms, other than square wave, the Model 3152 is limited to signal frequencies of 10 MHz or less. To place the Model 3152 in Triggered mode, use the following command:

```
INITiate:CONTInuous {OFF | ON}
```

OFF places the instrument in Triggered mode. ON restores continuous operation.

The query:

```
INITiate:CONTInuous?
```

queries the instrument operating mode parameter and returns "0" (OFF) or "1" (ON).

The Model 3152 can be set to operate in Gated mode only after the INIT:CONT OFF command has been received. The output remains at a certain DC level as long as the TRIG IN signal from the front panel remains inactive. A TTL level signal is used to stimulate the TRIG input. The gating signal can be programmed to be either active high or active low. Each time the proper level is present at the trigger input connector, the Model 3152 generates output waveforms as long as the gate signal is present. When the gate signal is de-asserted, the output completes the last cycle and resumes position at a DC level equal to the last point of the waveform.

Gated mode operates on standard waveforms, arbitrary waveforms, and on sequences of waveforms. Observe the limitations of the gating signal as listed in the specification section of this manual. To place the Model 3152 in Gated mode, use the following commands:

```
INIT:CONT OFF
TRIGger:GATE {OFF | ON}
```

The default state for the Gated mode is OFF. Turning Gated mode ON automatically turns Burst mode off.

The query:

```
TRIGger:GATE?
```

queries the gate state and returns "0" (OFF) or "1" (ON).

Burst Mode

Burst mode is very similar to Triggered mode with the exception that only one trigger signal is needed to generate a counted number of output waveforms. In Burst mode, the output remains at a certain DC level as long as the TRIG IN signal from the front panel remains inactive. A TTL signal is used to stimulate the TRIG input. The generator is sensitive to either the rising edge or the falling edge. Each time a transition at the trigger input occurs, the Model 3152 generates a number of output cycles that have been programmed in the burst count parameter. At the end of the burst, the output resumes position at a DC level equal to the last point of the waveform. The burst count is programmable from 1 to 10^6 . The default burst value is 1.

The Burst mode operates on standard waveforms and arbitrary waveforms. Note that the Model 3152 cannot operate in Sequence and Burst modes simultaneously. Observe the limitations of the trigger signal as listed in the specification section of this manual. To place the Model 3152 in Burst mode, use the following commands:

```
INITiate:CONTinuous OFF
TRIGger:BURSt ON
TRIGger:COUNt <counts>
```

INIT:CONT OFF places the Model 3152 in a non-continuous mode. TRIG:BURS ON turns the burst function on. The TRIG:COUN specifies the number of waveforms output after a qualified trigger signal. To ensure proper operation, enable Burst mode after setting up the burst parameters. When Burst mode is enabled, previously programmed Trigger or Gate modes turn off automatically.

The query:

```
TRIGger:BURSt?
```

queries the state off Burst mode and returns "0" (OFF) or "1" (ON).

Selecting the Trigger Source

The query:

```
TRIGger:COUNT?
```

queries the burst count and returns an integer.

When an external source is not available, the operator has the option to use either the built-in trigger generator or a TTLTRG<n> signal to stimulate its output. Use the following command to select the trigger source for the instrument:

```
TRIGger:SOURce:ADVance {EXTernal | INTernal | TTLTrg<n>}
```

EXT is the default trigger source for the Model 3152. Select the TTLT<n> option with <n> ranging from 0 to 7 to use one of the TTLTRG lines available on the backplane. Select INT to use the internal trigger generator. Remember to program the period of this generator (as shown later).

The query:

```
TRIGger:SOURce:ADVance?
```

queries the trigger source and returns EXT, INT or TTLT<n>.

Using the Internal Trigger Generator

The internal trigger generator is a free-running generator which is asynchronous with the main output generator. When the internal trigger source is selected, the front panel TRIG IN signal is inactive. The internal trigger generator is also available in Burst mode, but has no effect in Gated mode. To use the internal trigger generator, place the instrument in Triggered mode, but select the internal trigger generator as the trigger source. Then use the following command to program an internal trigger period:

```
TRIGger:TIMer <value>
```

The period of the internal trigger generator can be programmed from 15 μ s to 1000 s. The default period is 100 μ s. The internal trigger generator is ignored when either an external or TTLT source is enabled.

The query:

```
TRIGger:TIMer?
```

queries the period of the internal trigger generator and returns a value in seconds.

Selecting the Trigger Slope

The trigger slope command selects the sensitive edge of the trigger signal that is applied to the TRIG IN connector. The Model 3152 can be made sensitive to either positive or negative transitions. Use the following command to select the edge sensitivity for the trigger signal:

```
TRIGger:SLOPe {POSitive | NEGative}
```

Positive going transitions will trigger the Model 3152 when the POS option is selected. Negative transitions will trigger the Model 3152 when the NEG option is selected. POS is the default slope.

The query:

```
TRIGger:SLOPe?
```

queries the trigger slope and returns POS or NEG.

Using the Trigger Delay

The trigger delay command delays the output of a triggered or burst waveform by a specified number of sample clock cycles by a value of 10 to 2 million cycles. Actual delay is calculated by $T_{\text{delay}} = D_{\text{cycles}} / f_{\text{SCLK}}$ where D_{cycles} is the programmed delay and f_{SCLK} is the sample clock frequency setting. Enable or disable this feature by setting the STATE:

```
TRIGger:DELAy:STATe {OFF | ON}
```

```
TRIGger:DELAy: <value>
```

The queries:

```
TRIGger:DELAy:STATe?
```

```
TRIGger:DELAy?
```

query the state of the trigger delay feature and the delay value.

Revised 4/19/00

Selecting the Trigger Level

The trigger level command sets the threshold level at the trigger input connector. Trigger levels are adjustable from -10 V to +10 V with up to 4 digits. Trigger level resolution is always 10 mV. Use the following command to set the trigger level for the trigger signal:

```
TRIGger:LEVel <value>
```

Set the trigger level for the signal which is applied to the TRIG IN. The default value is 1.6 V so there is not need to modify this value if you apply a TTL level signal to the trigger input.

```
TRIGger:LEVel?
```

Query the trigger level. Returns a value in volts.

Using the Soft Trigger

There are a number of commands that are available to trigger the Model 3152. The soft trigger command is one of them. To use the soft trigger command, place the instrument in the TRIG:SOUR EXT mode. Soft trigger is ignored in the internal or TTLTrg<n> modes. Use the following SCPI commands to trigger the instrument:

TRIGger

The IEEE-STD-488.2 common command *TRG will have the same effect. Use either software command to trigger the Model 3152 in Trigger, Burst and Triggered Sequence Advance modes.

Generating Arbitrary Waveforms

The Model 3152 cannot generate arbitrary waveforms without first loading them into memory. A description of the arbitrary waveform function and an explanation on how to load waveforms into memory is given in the following paragraphs.

What Are Arbitrary Waveforms?

Arbitrary waveforms are generated from digital data points which are stored in memory. Each data point has vertical resolution of 12 bits (4096 points), i.e., each sample is placed on the vertical axis with a precision of 1/4096.

Arbitrary waveform memory has the capacity to store up to 64K of horizontal data points (512K optional). Each horizontal point has a unique address - the first being 00000 and the last 64435. In cases where smaller wavelengths are required, the Model 3152's waveform memory can be divided into smaller segments. Then it is possible to select which segment is sampled, how many times and in what sequence.

When the instrument is programmed to output arbitrary waveforms, a clock samples the data points (one at a time) from address 0 to the last address. The rate at which each sample is replayed is defined by the sample clock rate parameter. The Model 3152 provides programmable sample clock rates from 100 mHz to 100 MHz.

Unlike the built-in standard waveforms, arbitrary waveforms must first be loaded into the instrument's memory. Correct memory management is required for best utilization of the arbitrary memory. An explanation of how to manage the arbitrary waveform memory is given in the following paragraphs.

Arbitrary Memory Management

The Model 3152's arbitrary memory consists of a fixed length of 65,536 words. 1K is always reserved for the built-in standard waveforms. The maximum size arbitrary waveform that can be loaded into memory is 64536 points long. A 512K point RAM is offered as an option in cases where a larger memory bank is required. For the 512K point option, the maximum waveform size is 523288 points. It is not always necessary to use the complete length of this memory. The memory can be partitioned into smaller segments and different waveforms can be loaded into each segment. The memory can be partitioned into 4096 segments, each having a unique length and identity. Minimum segment length is 10 points. Information on how to partition the memory is given in the following paragraphs.

Memory Management Commands

Arbitrary memory can be divided into smaller segments; up to 4096 different arbitrary waveforms can be generated with the Model 3152. The length of each segment is left totally to the user's discretion. To partition the arbitrary waveform memory, use the following command:

```
TRACe:DEFine <segment_number>,<length>
```

Note that numbers, not names, are assigned to segments that are defined. Numbers can range from 1 through 4096. The order of assignment is not important as long as the size of the segments, having already been defined, is not changed. You cannot query the TRAC:DEF command so you must keep good track if you intend to partition the memory into many segments.

If a mistake is made and removal of one or more segments from the active directory is needed, use the following command:

```
TRACe:DELeTe <n>
```

where <n> is the number of the segment to be removed from memory. Note that if a segment is deleted, the memory portion that belonged to this segment is no longer accessible. The next segment that is defined will be placed after the last defined memory segment. However, if the last segment is deleted, the next downloaded segment will be written on top of the deleted one. There is danger that by using the TRAC:DEL command often large portions of memory will remain unused. It is, therefore, recommended to periodically clear the entire memory and only reload waveforms that will be used.

To partition the memory from the beginning, use the following command:

```
TRACe:DELeTe: ALL
```

CAUTION This command will destroy waveforms that were previously loaded into memory. After using this command, waveform segments will line-up from address 0 upwards.

Loading Arbitrary Waveforms

There are two ways to load waveforms into the Model 3152; using a graphical user interface, i.e., WaveCAD, or low-level programming. When using WaveCAD, disregard most of this chapter as WaveCAD does the work for you. When writing your own code, use the following commands to load data into a specific memory segment.

First, define the work area. Define the segment number and its associated length. Segment length must be an even number. For example, to use segment number 8 and give it a length of 1000 points, use this command:

```
TRACe:DEFine 8,1000
```

Next, make segment 8 the active segment. The active segment must be selected because as waveforms are loaded, the Model 3152 must be notified as to where to place the data it receives. Select the active segment using the following command:

```
TRACe:SElect 8
```

The next step is to transfer data to the active segment. Data is loaded into the Model 3152 using high-speed binary transfer. A special command is defined by IEEE-STD-488.2 for this purpose. High speed binary transfer allows any 8-bit bytes (including extended ASCII code) to be transmitted in a message. This command is particularly useful for sending large quantities of data. The Model 3152 uses this command to receive waveforms from the controller:

```
TRACe #42000<binary_block>
```

This command causes the transfer of 2000 bytes of data (1000 points) into the active memory segment. The ASCII "#" (\$23) is the start of the binary data block. "4" designates the number of digits that follow. "2000" is the even number of bytes to follow. The generator represents binary data as 12-bit integers which are sent as two bytes. Therefore, the total number of bytes is always twice the number of data points in the waveform. For example, 2000 bytes are required to download a waveform with 1000 points. Bytes are sent in byte-high, byte-low order. The FORM:SWAP command can be used to reverse this order.

When sending binary blocks to the Model 3152, the final byte must be transmitted with the EOI bit set. Carriage Return and Line Feed will not be detected as terminators. This permits the values OD_{HEX} and OA_{HEX} to be used as data points.

The IEEE-STD-488.2 definition of Definite Length Arbitrary Block Data Format is demonstrated in **Figure 3-1**.

Figure 3-1 Definite Length Arbitrary Block Data Format

6-bits of data are sent to the Model 3152 although only 12 bits are required to generate the waveform. The order of bytes and bits and their values are shown in **Figure 3-2**.

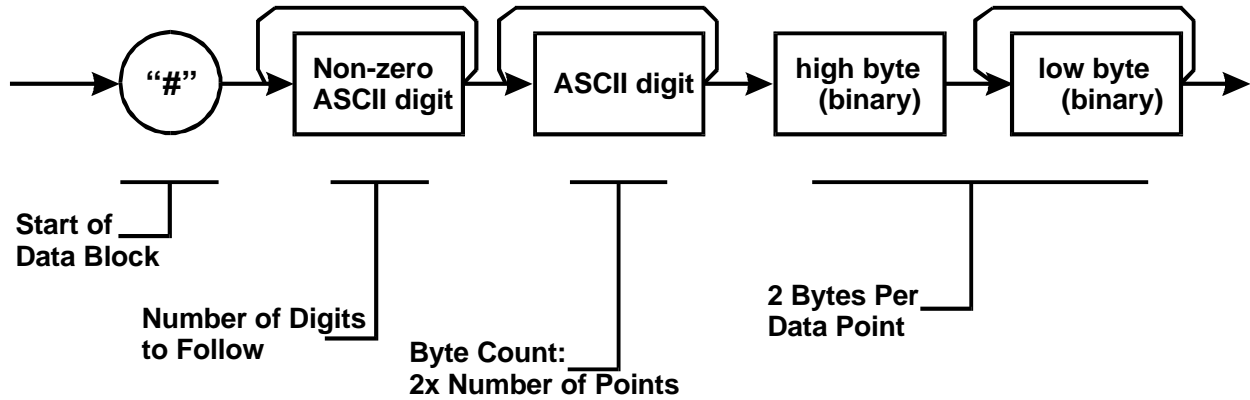
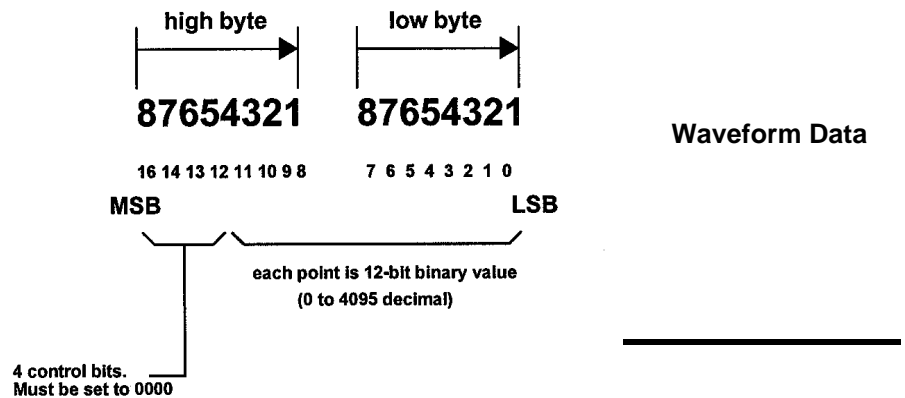

Figure 3-2 12-Bit Format



NOTE **T h e M o d e l 3 1 5 2
o p e r a t e s i n i n t e r l a c e d
m o d e w h e r e t w o m e m o r y c e l l s g e n e r a t e o n e b y t e o f d a t a .
S e g m e n t s i z e c a n b e p r o g r a m m e d i n e v e n - n u m b e r s o n l y a n d
t h e g e n e r a t o r c a n a c c e p t b i n a r y b l o c k s o f d a t a t h a t a r e
m u l t i p l e s o f 4 o n l y . F o r e x a m p l e , 2 0 0 0 b y t e s w i l l b e a n
a c c e p t a b l e b i n a r y b l o c k . 2 0 0 2 i s n o t a m u l t i p l e o f 4 , t h e r e f o r e ,
t h e g e n e r a t o r w i l l a u t o m a t i c a l l y a d j u s t t h e s i z e t o 1 0 0 2 p o i n t s
a n d g e n e r a t e a n e r r o r m e s s a g e .**

Reversing Byte Order

Binary data is sent to the Model 3152 in byte-high byte-low order. This order can be reversed using the following command:

```
FORMat:BORDER {NORMal | SWAPped}
```

The default is NORM. This command is useful only for binary block transfers.

The query:

```
FORMat:BORDER?
```

queries the byte order configuration and returns "NORM" or "SWAP".

Using Shared Memory

Shared memory transfer is the fastest way to get waveforms into the Model 3152. In shared memory mode, the Model 3152's CPU disconnects from the waveform memory and passes access to the VXIbus. The internal data bus is connected directly to the VXIbus, and data is downloaded into the memory in binary blocks using A24 memory space. Byte and bit order are the same as with the Arbitrary Block transfers as shown in **Figures 3-1** and **3-2**. After the data is loaded into the Model 3152, control is returned to the instrument.

In shared memory mode, the Model 3152's memory acts similar to Direct Memory Access (DMA). The instrument has to be told when to receive data, send data, surrender control or gain control. The Model 3152 has an auto-increment address counter. The Slot 0 Controller need only select the base address for both write and read cycles. Shared Memory commands are explained below.

To write to or read from a segment, the user must first define the segment using the command TRACe:DEFine. The trace must then be selected using the command TRACe:SElect. Refer to Loading Arbitrary Waveforms for more information.

The command:

```
SMEMory:MODE {READ | WRITe}
```

sets the instrument to receive data from (WRITE) or send data (READ) to the VXIbus.

The query:

SMEMory:MODE?

queries the shared memory mode and returns READ or WRITE.

The command:

SMEMory:STATe {OFF | ON}

places the Model 3152 in the shared memory state when ON is selected. After this, the instrument cannot accept normal commands. Data must be sent to the synthesizer using shared memory access. Normal command mode is resumed when the SMEMory:STATe is changed to OFF.

The query:

SMEMory:STATe?

queries the shared memory state and returns "0" (OFF) or "1" (ON).

The following sequence should be used for shared memory transfers.

1. Slot 0 sends commands:

```
TRAC:DEF (n),(m)           (Shared Memory write only)
TRAC:SEL <n>
SMEM:MODE {READ | WRITE}
SMEM:STATE ON
```

2. Slot 0 repeatedly sends:

```
*OPC?
```

When response is 1, shared memory transfers may start.

3. Slot 0 sends command:

```
SMEM:STATE OFF
```

once data transfer is complete.

The *OPC? Response is set to 1 when the Model 3152 has transferred memory access from the internal CPU to shared memory. This typically takes a few milliseconds.

Sequence

Sequenced waveforms are a means of adding more capability to the synthesizer. The Model 3152 can link 4096 segments and loop on each segment up to 10^6 times.

Generating Sequenced Waveforms

What Are Sequenced Waveforms?

Sequenced waveforms are made of a number of arbitrary waveforms which can be linked and repeated in various manners. Sequenced waveforms are generated from waveforms stored in a library of memory segments. Before using a sequence of waveforms, load arbitrary memory with the required waveforms. Use TRAC# or shared memory methods to load waveforms into memory.

Information on how to partition the memory and load waveforms is given in the section entitled **Generating Arbitrary Waveforms**.

An example of how sequenced waveforms work is demonstrated in the following figures. **Figure 3-3** shows a $\text{sine}(x)/x$ waveform that was loaded into segment 1. **Figure 3-4** shows a sine waveform that was loaded into segment 2. **Figure 3-5** shows a pulse waveform that was loaded into segment 3.

The sequence generator lets you link segments in user-defined order and repeat each segment as many times as needed.

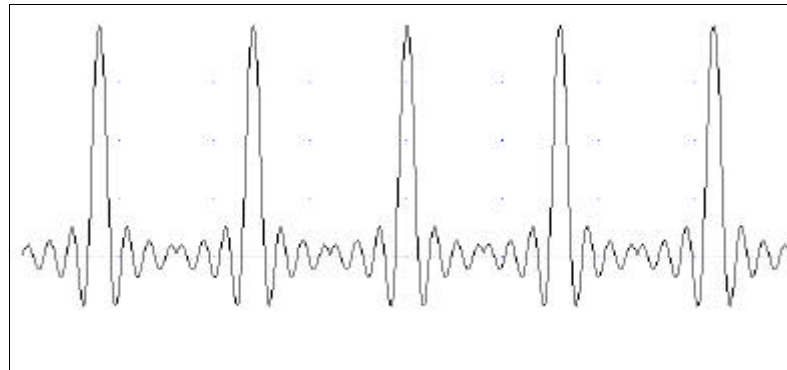
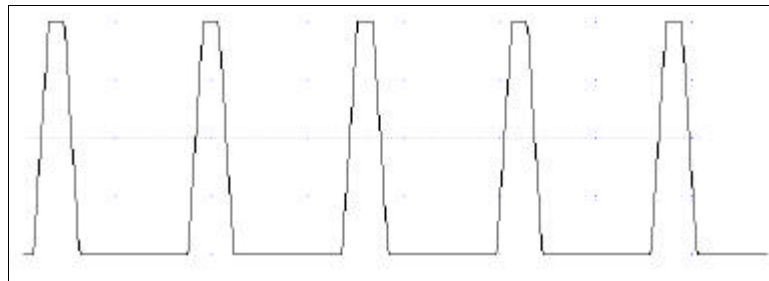
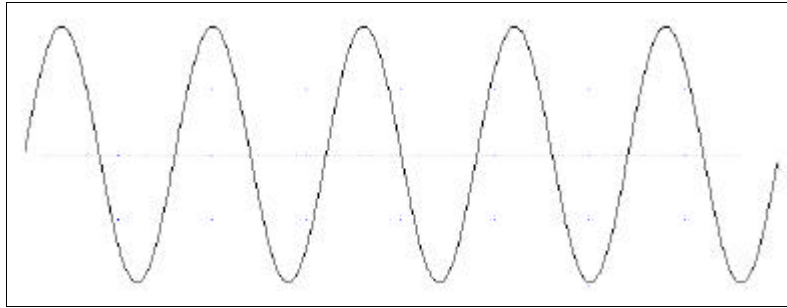

Figure 3-3 Sin(x)/x Waveform Loaded Into Segment 1



**Figure 3-4 Sine
Waveform Loaded
Into Segment 2**

Figure 3-5 Pulse Waveform Loaded Into Segment 3

Figure 3-6 shows a sequence of waveforms that were stored in three different memory segments. Note that segment number 2 is generated first and repeated twice, segment 3 follows once and then segment 1 is repeated four times.

Sequence Commands

The following is an overview of how to define and program a sequence of arbitrary waveforms.

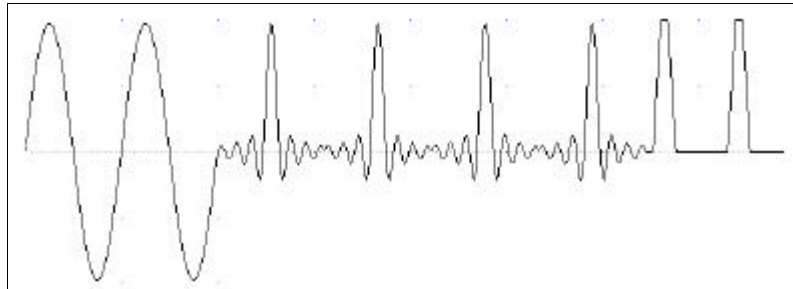

Figure 3-6 Sequenced Waveforms - Continuous Advance Mode

A sequence is made of steps. A step can stand on its own or link to another step. It is possible to have only one step in a sequence but the output will look like a continuous waveform. If only one step is specified and the Model 3152 is placed in Triggered mode, the output will behave as it would in Burst mode where the repeat number replaces the burst count parameter.

Aside from step numbers, each step has two other parameters: segment number and repeat counter. The segment number specifies which segment will be linked, and the repeat counter specifies how many times the segment will repeat. Use the following command to generate a sequence:

```
SEquence:DEFine {<step_number>,<segment_number>,  
<repeat>}
```

Use this command up to 4095 times, each time for a different step and for a different segment number and repeat combination. Note that the same segment number can be used for different sequence steps. The SEQ:DEF command does not change the FUNC:MODE setting. Unless the FUNC:MODE SEQ command is used, the SEQ:DEF command will have no immediate effect on the output waveform or function.

The sequence generator goes through the steps in descending order. In the continuous operating mode, the sequence is repeated automatically after the last step has been completed. When the generator is set to operate in Triggered mode, the output stops at the last point of the last waveform in the sequence. In Gated mode, the sequence is always completed after the gate stop signal.

If removal of a step from the sequence is required, use the following command:

```
SEquence:DELeTe <n>
```

where <n> is the step number to be removed from the sequence.

To delete all sequences, use the following command:

```
SEquence:DELeTe:ALL
```

CAUTION The above command will destroy sequences previously loaded into memory.

Triggered Sequence Advance

Triggered Sequence Advance is a special case sequenced mode. In Triggered Sequence Advance mode, the Model 3152 idles between steps until a valid trigger signal is sensed. The trigger source can be selected from a number of options:

- ! An external trigger signal applied to the front panel TRIG IN connector
- ! An internal trigger generator whose period is programmable
- ! VXIbus TTLTRG<n> triggers
- ! soft triggers.

A sequence operating in Continuous mode can be seen in **Figure 3-6**. **Figure 3-7** shows an example of the same sequence in Triggered Sequence Advance mode.

Figure 3-7 Sequenced Waveforms - Triggered Advance Mode

Triggered Sequence Advance Commands

Placing the Model 3152 in Triggered Sequence Advance mode is done in Triggered mode only. First, prepare the sequence of waveforms using the commands that were explained before. Second, place the instrument in Triggered mode using the INIT:CONT OFF command. To place the Model 3152 in Triggered Sequence Advance mode, use the following command:

`SEquence:ADVance {AUTO | TRIGger}`

AUTO specifies the normal continuous advance and TRIGger

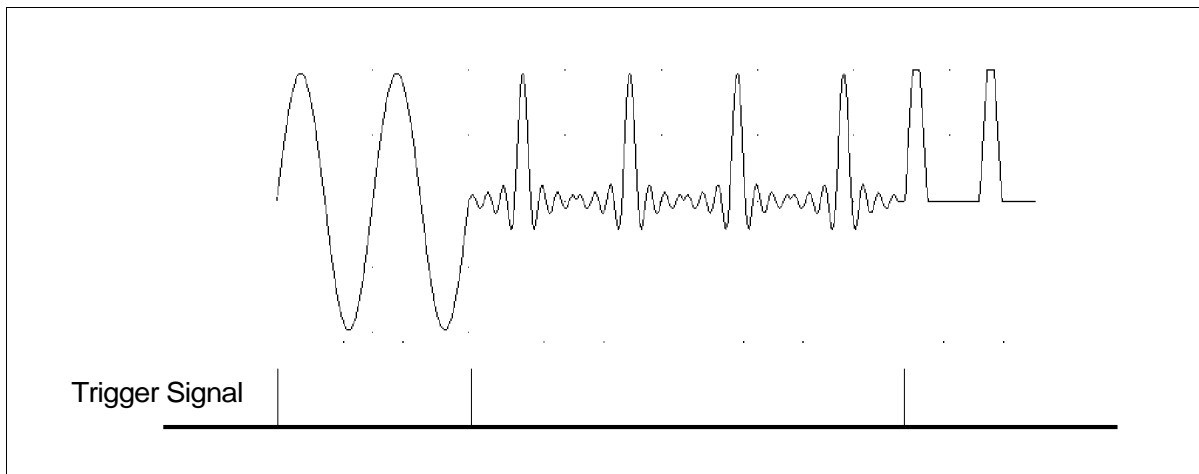

places the instrument in Triggered Sequence Advance mode.

The query:

`SEquence:ADVance?`

queries Triggered Sequence Advance mode and returns AUTO or TRIG.

Backplane Inter-Module Synchronization

Although multiple Model 3152s within one chassis run off a common clock (CLK10), their outputs are not synchronized to each other. If the same waveform length and clock rates for two modules are selected and both are displayed on an oscilloscope, the outputs may look as though they are synchronized even though they are not. The waveforms may not start at the same point along the waveform. If another waveform is selected or if the same waveforms are reprogrammed, you may notice that the phase relationship between the two modules has changed again.

CAUTION Phase synchronization requires the use of the VXI ECLTRG0 and ECLTRG1 signals. Other VXI instruments must not drive ECLTRG0/1 while phase synchronization is enabled.

There are phase synchronization commands that can tightly control phase offsets between two or more Model 3152s. These commands are described below. To use the following commands, two Model 3152s are required. When synchronizing modules, the waveforms in each module must have **exactly** the same number of points.

First, load the waveforms in all the modules in preparation for phase synchronization. Then select one Model 3152 as master and program it using the following commands:

```
PHASe[1]:LOCK ON  
PHASe[1]:SOURce MAST
```

The above Model 3152 is now programmed as master. Next, program the other Model 3152 modules as slaves (SLAVE) and program their phase offset in relation to the master. As an example, program the second and third Model 3152 with 120 and 240 degree offsets, respectively.

Use the following commands on the second Model 3152:

```
PHASe[1]:SOURce SLAVE  
PHASe[1]:LOCK ON  
PHASe[1]:ADJust 120
```

Use the following commands on the third Model 3152:

```
PHASe[1]: SLAVE  
PHASe[1]:LOCK ON  
PHASe[1]:ADJust 240
```

The three Model 3152 modules are now synchronized

The sample clock rate has no effect on phase offset accuracy. However, when trying to synchronize modules that are programmed to output waveforms with few memory points, a ± 1 count error between modules may be seen. To remove this error, use the following command:

```
PHASe[1]:LOCK:NULL
```

CAUTION

The **PHASe:NULL** command toggles between removing one count and adding one count. Therefore, if there was no error, sending this command may add a 1 count error.

The query:

```
PHASe[1]:LOCK?
```

queries the Phase Lock mode and returns "0" (OFF) or "1" (ON).

The query:

```
PHASe[1]:ADJust?
```

queries the phase offset and returns a value in degrees.

In query:

```
PHASe[1]:SOUR?
```

queries the phase lock source and returns MAST or SLAV.

Front-Panel Phase Synchronization

The Model 3152 can phase lock to an external reference which is applied to the trigger input. The locking process is done automatically by the generator. There is no need for the user to initiate or set the generator's lock-in range for this mode. A front-panel LED illuminates when the reference signal is valid and the Model 3152 locks on the external signal. After lock has been achieved, you may shift the phase between the reference and the generator from -180° to $+180^\circ$.

NOTE

Phase offset resolution depends on the number of waveform samples. For instance, if you have 1000 waveform samples, there is no problem with adjusting the phase offset in 1° increments ($360^\circ / 1000 < 1$). As another example, if you have only 10 waveform samples, the best phase offset increments are only 36° ($360^\circ / 10 = 36^\circ$).

PLL Commands

There is a special fine adjustment for phase offset with a 36° range. This adjustment is useful in places where a 36° gap is too wide. The fine phase adjustment improves phase offset settings to 0.01° and can be used in conjunction with the coarse phase offset adjustment at any phase offset setting point.

In PLL mode, the Model 3152 can be used as a slave only. Use the following commands to program the Model 3152 to lock to an external reference.

PHASe2:LOCK ON

This command places the Model 3152 in PLL mode. If no valid reference signal is applied to the trigger input, the PLL ON LED remains off. If you feel that the 3152 should lock and it does not, check the following:

1. Make sure that trigger level is adjusted correctly
2. Make sure that the 3152 frequency setting permits lock in the required range. Two graphs, one for fixed mode and the other for user mode are given in Appendix A, showing the lock range relationship between the reference and the internal frequency settings.

PHASe2:ADJust <value>

applies a phase offset between the reference signal and the main output. The default value is 0°. Phase offsets can be adjusted between -180° and +180°. Best resolution for this parameter is 1°, degrading to 36° at 10 point waveform samples.

PHASe2:FINE <value>

applies a fine adjustment to the absolute setting of the PHAS[2]:ADJ command. The default value is 0°. Fine phase adjustment is usable between -36° and +36°.

As an example of the use of this command, we'll take a 100 sample waveform. The best phase offset resolution for this waveform is 3.6° ($360^\circ / 100$ points). If you need to set an offset of 50°, the Model 3152 will accept this value, but will not be able to set this offset correctly. Since the resolution is 3.6°, the output will offset by 50.4°. You can now correct the phase to exactly 50° by using the PHAS:FINE -0.4 command.

PHASe2:LOCK?

queries the PLL's state. It returns a "0" (OFF) or "1" (ON).

PHASe2:ADJust?

queries the PLL offset. It returns a value in degrees.

PHASe2:FINE?

queries the PLL's fine offset. It returns a value in degrees.

Using the Frequency Counter

In PLL mode, the Model 3152 uses an autoranging counter circuit to measure frequencies of reference signals at the trigger input. This built-in counter is made available to you as long as the signal at the trigger input is valid and the PLL ON LED illuminates. Frequencies are measured from 500 Hz to 10 MHz with 4 digit resolution.

To measure external frequencies you must first place the model 3152 in PLL mode. Use the following command :

PHASe2:LOCK ON

If no valid reference signal is applied to the trigger input, the PLL ON LED remains off. If you feel that the 3152 should lock and it does not, do the following:

1. Check that trigger level is adjusted correctly. You may change trigger level settings using the TRIG:LEV command. The default trigger level setting is 1.6 V.
2. Check that the 3152 frequency setting permits lock in the required range. Two graphs, one for fixed mode and the other for user mode are given in Appendix A, showing the lock range relationship between the reference and the internal frequency settings.

FREQuency:EXTernal?

queries the external frequency. Returns frequency in Hz. 0.000e0 reading indicates that no valid signal is available at the trigger input.

Using the Phase Modulation Input

The phase modulation function operates in conjunction with the front-panel PLL function. The PM Input accepts signals that phase modulate the main output frequency after it has locked to an external reference. Note that this input is active at all times and unless you intend to use this function, do not connect any cables to this input during normal operation of the Model 3152.

When the Model 3152 is placed in PLL mode, the phase of the main output signal may be shifted from the reference phase using the phase modulation input. Although not very accurate, the phase modulation input provides a way of phase offsetting the main output above and below 360°.

Amplitude Modulation Commands

The PM IN is sensitive to voltage levels. Applying 1 V to this input generates a phase offset of 20°. Likewise, applying -1 V to this input generates a phase offset of -20°. You may apply 20 V to this input and generate a phase offset of 400°. The applied frequency range is dc to 10 KHz, depending on the lock frequency and the number of waveform samples.

Arbitrary waveforms stored in memory segments are used as modulating envelopes in Amplitude Modulation mode. The modulated carrier is always a sine waveform with its frequency set in points. The first step in modulating a waveform is to generate an arbitrary waveform either from the standard function library or by downloading a waveform from the controller.

The command:

```
AM <value>
```

sets the internal modulation depth in percent. Select values from 1% to 200%. The default setting for AM depth is 50%.

The query:

```
AM?
```

queries the modulation depth and returns a value in percent.

The command:

```
AM:INTernal:FREQuency <value>
```

sets the frequency of the carrier sine waveform. The frequency of the carrier wave is programmed in points. Select from 10 to 500 points. The default setting for the carrier frequency is 100 points. The frequency of the carrier wave can be computed from the sampling clock frequency divided by the number of points in the active segment. Use the `FREQ:RAST?` command to determine the current sampling clock frequency. The maximum carrier frequency is the sampling clock frequency divided by 10 points. The envelope frequency should be less than the carrier frequency.

The query:

```
AM:INTernal:FREQuency?
```

queries the carrier frequency and returns a value in points.

The command:

```
AM:EXECute
```

enables amplitude modulation. To ensure proper operation, enable the amplitude modulation after setting up the other modulation parameters. Amplitude modulation cannot be turned on and off. Therefore, ensure that the original arbitrary waveform is available in another memory segment as a back-up.

System-Related Commands

System-related commands are used to place the instrument in a known state, clear the instrument to its defaults, or to query the generator for its errors or identity. The following is an overview of the system-related commands.

The query:

SYSTem:ERRor?

reads one error from the error queue. A record of up to 30 errors can be stored in the generator's error queue. Errors are retrieved in first-in-first-out (FIFO) order. The first error returned is the first error that was stored. When all errors have been read from the queue, the generator returns +0, "No error".

If more than 30 errors have occurred, the last error stored in the queue (the most current error) is replaced with -350,"Too many errors". No additional errors are stored until all errors have been removed from the queue. The error queue is cleared only when power is cycled off or after the execution of a *CLS command. The *RST command does not clear the error queue.

The query:

SYST:ERR

queries the system error queue and returns a string with the following format: -102,"Syntax error". A complete list of errors that can be detected by the generator is given in **Chapter 4**.

The query:

SYSTem:VERSion?

queries the generator to determine the present SCPI revision and returns a string similar to "1993.0"

The query:

*IDN?

reads the generator's identification string. The generator returns four fields separated by commas. The first field is the manufacturer's name, the second field is the model number, the third field is not used (always "0") and the fourth field is the firmware version number. The command returns "Racal Instruments,3152,0,1.0".

The commands:

RESet
*RST

reset the generator to its default state. The *RST and RES commands have no effect on status registers, VXIbus states, VXI address or SCPI command set.

The query:

*OPT?

queries the waveform memory length installed in the 3152. The response is "0" for 64K and "1" for 256K or 512K.

This page was intentionally left blank

SCPI Command Reference

What's In This Chapter

This chapter contains reference information for programming the Model 3152. Standard Commands For Programmable Instruments (SCPI) convention rules and syntax are explained in detail. **Table 4-1** lists all SCPI commands used for programming the Model 3152. The command summary for each SCPI model is also included in this chapter.

This chapter teaches you how to use SCPI commands to control functions, modes, waveforms and other aspects of the instrument. Prior understanding of SCPI programming is necessary for low level programming of the Model 3152.

Introduction To SCPI Language

Commands to program the instrument over the MXI interface bus are defined by the SCPI 1993.0 standard. The SCPI standard defines a common language protocol. It goes one step further than IEEE-STD-488.2 and defines a standard set of commands to control every programmable aspect of the instrument. It also defines the format of command parameters and the format of values returned by the instrument.

SCPI is an ASCII-based instrument command language designed for test and measurement instruments. SCPI commands are based on a hierarchical structure known as a tree system. In this system, associated commands are grouped together under a common mode or root, thus forming subsystems. Throughout this manual, the following conventions are used for SCPI command syntax.

Square Brackets ([])	Enclose optional keywords or parameters
Braces ({ })	Enclose parameters within a command string
Triangle Brackets (< >)	Substitute a value for the enclosed parameter
Vertical Bar ()	Separate multiple parameter choices
Bold Typeface Letters	Designate factory default values

Part of the OUTPUT subsystem is shown below to illustrate the tree system:

```
OUTPUT
  :FILTER
    [:LPASs]
      :FREQuency {20MHz|25MHz|50MHz}
        [:STATe] OFF|ON
          [:STATe] OFF|ON
```

OUTPUT is the root keyword of the command; FILTER and STATe are second level keywords. FREQuency and STATe are third level keywords. A colon (:) separates a command keyword from a lower level keyword.

Command Format

The format used to show commands in this manual is shown below:

```
FREQuency {<frequency>|MINimum|MAXimum}
```

The command syntax shows most commands (and some parameters) as a mixture of upper and lowercase letters. The uppercase letters indicate the abbreviated spelling for the command. For shorter program lines, send the abbreviated form. For better program readability, send the long form.

For example, in the above syntax statement, FREQ and FREQUENCY are both acceptable forms. Use upper or lowercase letters. Therefore, FREQ, FREQUENCY, freq, and Freq are all acceptable. Other forms such as FRE and FREQUEN will generate an error.

The above syntax statement shows the frequency parameter enclosed in triangular brackets. The brackets are not sent with the command string. A value for the frequency parameter (such as "FREQ 50e+6") must be specified.

Some parameters are enclosed in square brackets ([]). The brackets indicate that the parameter is optional and can be omitted. The brackets are not sent with the command string. If an optional parameter is not specified, the synthesizer uses a default value.

Command Separator

A colon (:) is used to separate a command keyword from a lower level keyword as shown below:

```
SOUR:FUNC:SHAP SIN
```

A semicolon (;) is used to separate commands within the same subsystem, and can also minimize typing. For example, sending the following command string:

```
TRIG:SOUR:ADV INT;BURS ON;INT:RATE 5e-3
```

is the same as sending the following three commands:

```
TRIG:SOUR:ADV INT
TRIG:BURS ON
TRIG:INT:RATE 5e-3
```

Use the colon and semicolon to link commands from different subsystems. For example, in the following command string, an error is generated if both the colon and the semicolon are not used.

```
OUTP:STATE ON;:TRIG:STAT ON
```

The MIN and MAX Parameters

Substitute MINimum or MAXimum in place of a parameter for some commands. For example, consider the following command:

```
FREQuency {<frequency>|MINimum|MAXimum}
```

Instead of selecting a specific frequency, substitute MIN to set the frequency to its minimum value or MAX to set the frequency to its maximum value.

Querying Parameter Setting

Query the current value of most parameters by adding a question mark (?) to the command. For example, the following command sets the output function to square:

```
SOUR:FUNC:SHAP SQR
```

Query the output function by executing:

```
SOUR:FUNC:SHAP?
```

Query Response Format

The response to a query depends on the command sent to the instrument to generate the query response. In general, a response to a query contains current values or settings of the synthesizer. Commands that set values can be queried about their current value of the setting. Commands that set modes of operation can be queried about their current mode setting. IEEE-STD-488.2 common queries generate responses which are common to all instruments that are connected to the GPIB interface.

SCPI Command Terminator

A command string sent to the function generator must terminate with a <new line> character. The IEEE-STD-488 EOI (end-or-identify) message is interpreted as a <new line> character. A <carriage return> followed by a <new line> is also accepted. Command string termination always resets the current SCPI command path to the root level.

IEEE-STD-488.2 Common Commands

The IEEE-STD-488.2 standard defines a set of common commands that perform functions like reset, trigger and status operations. Common commands begin with an asterisk (*), are four to five characters in length, and may include one or more parameters. The command keyword is separated from the first parameter by a blank space. Use a semicolon (;) to separate multiple commands as shown below:

```
*RST; *STB?; *IDN?
```

SCPI Parameter Type

The SCPI language defines several different data formats to be used in program messages and response messages.

Numeric Parameters

Commands that require numeric parameters will accept all commonly used decimal representations of numbers including optional signs, decimal points, and scientific notation. Special values for numeric parameters like MINimum and MAXimum are also accepted.

Engineering unit suffixes with numeric parameters (e.g., MHz or KHz) can also be sent. If only specific numeric values are accepted, the function generator will ignore values which are not accepted and will generate an error message. The following command is an example of a command that uses a numeric parameter:

```
VOLT:AMPL <amplitude>
```

Discrete Parameters

Discrete parameters are used to program settings that have a limited number of values (i.e., FIXed, USER and SEquence). They have short and long form command keywords. Upper and lowercase letters can be mixed. Query responses always return the short form in all uppercase letters. The following command uses discrete parameters:

```
SOUR:FUNC:MODE {FIXed | USER | SEquence}
```

Boolean Parameters

Boolean parameters represent a single binary condition that is either true or false. The synthesizer accepts "OFF" or "0" for a false condition. The synthesizer accepts "ON" or "1" for a true condition. The instrument always returns "0" or "1" when a boolean setting is queried. The following command uses a boolean parameter:

```
OUTP:FILT { OFF | ON }
```

The same command can also be written as follows:

```
OUTP:FILT {0 | 1 }
```

Arbitrary Block Parameters

Arbitrary block parameters are used for loading waveforms into the synthesizer's memory. Depending on which option is installed, the Model 3152 can accept binary blocks up to 1046576 bytes. The following command uses an arbitrary block parameter that is loaded as binary data:

```
TRAC:DATA#564000<binary_block>
```

SCPI Command Summary

Table 4-1 summarizes the complete SCPI command tree available to program the synthesizer over the GPIB. Refer to earlier sections in this manual for more complete details on each command.

Table 4-1 VXIbus Model 3152 SCPI Commands List Summary

Keyword	Parameter Form (Default in Bold)	SCPI 1993.0	Notes
:FORMat			
:BORDer	NORMal SWAPped	Confirmed	
:OUTPut		Confirmed	
[:STATe]	OFF ON	Confirmed	
:FLTer		Confirmed	
[:LPASs]		Confirmed	
:FREQuency	20MHz 25MHz 50MHz	Confirmed	
[:STATe]	OFF ON	Confirmed	
:ECLTrg<n>		Confirmed	
[:STATe]	OFF ON	Confirmed	
:TRIGger		Not confirmed	
:SOURce	BIT LCOMplete INTernal EXTernal	Not confirmed	
:TTLTrg<n>	(0;0;7)	Confirmed	(default;min;max)
[:STATe]	OFF ON	Confirmed	
:SYNC		Not confirmed	
:SOURce	BIT LCOMplete SSYNc HCLock	Not confirmed	
[:STATe]	OFF ON	Not confirmed	SYNC output inactive
:POSITION		Not Confirmed	
[:POINT]	(n-6;2;64536)	Not Confirmed	Even number, 64K memory
[:POINT]	(n-6;2;523288)	Not Confirmed	Even number, 512K memory
[:SOURce]		Confirmed	
:APPLy	FREQ,AMPL,OFFS	Not confirmed	
:SINusoid	FREQ,AMPL,OFFS,PHAS,POW	Not confirmed	
:TRIangle	FREQ,AMPL,OFFS,PHAS,POW	Not confirmed	
:SQUare	FREQ,AMPL,OFFS,DCYC	Not confirmed	
:PULSe	FREQ,AMPL,OFFS,DEL,WIDT,LEAD,TRA	Not confirmed	
:RAMP	FREQ,AMPL,OFFS,DEL,LEAD,TRA	Not confirmed	
:SINC	FREQ,AMPL,OFFS,NCYC	Not confirmed	
:GAUSsian	FREQ,AMPL,OFFS,EXP	Not confirmed	
:EXPOntial	FREQ,AMPL,OFFS,EXP	Not confirmed	
:DC	DC_AMPL	Not confirmed	
:USER	SEG<n>,SCLK,AMPL,OFFS	Not confirmed	
:FREQuency		Confirmed	
[:CW]	(1E6;100E-6;50E6) MINimum MAXimum	Confirmed	
:RASTer	(1E6;100E-3;100E6) MINimum MAXimum	Not confirmed	
:SOURce	INT EXT ECLTrg0	Not Confirmed	
:EXTernal?		Not confirmed	
:VOLTagE		Confirmed	
[:LEVel]		Confirmed	
[:IMMediate]		Confirmed	
[:AMPLitude]	(5.000;10E-3;16.00)	Confirmed	
:OFFSet	(0;-7.190;+7.190)	Confirmed	
:FUNCTion		Confirmed	
:MODE	FIXed USER SEQuence	Confirmed	
:SHAPE	SIN TRI SQU PULS RAMP SINC GAUS EXP DC	Confirmed	
:SINusoid		Not Confirmed	
:PHASe	(0;0;360)	Not Confirmed	
:POWer	(1;1;9)	Not Confirmed	
:TRIangle		Not Confirmed	
:PHASe	(0;0;360)	Not Confirmed	
:POWer	(1;1;9)	Not Confirmed	
:SQUare		Not Confirmed	
:DCYClE	(50;1;99)	Not Confirmed	
:PULSe		Confirmed	
:DELay	(10;0;99.9)	Confirmed	
:WIDTh (10;0;99.9)	Confirmed		
:TRANsition		Confirmed	
[:LEADing]	(10;0;99.9)	Confirmed	
:TRAILing	(10;0;99.9)	Confirmed	

SCPI Command Reference 4-6

Keyword	Parameter Form (Default in Bold)	SCPI 1993.0	Notes
:RAMP		Not Confirmed	
:DELay	(10;0;99.9)	Not Confirmed	
:TRANsition		Not Confirmed	
[:LEADing]	(10;0;99.9)	Not Confirmed	
:TRAiling	(10;0;99.9)	Not Confirmed	
:SINC		Not Confirmed	
:NCYClE	(10;4;100)	Not Confirmed	
:GAUSsian		Not Confirmed	
:EXPOnent	(10;1;200)	Not Confirmed	
:EXPOntial		Not Confirmed	
:EXPOnent	(-10;-200;200)	Not Confirmed	
:DC		Not Confirmed	
[:VOLTagE]		Not Confirmed	
[:IMMediate]		Not Confirmed	
[:AMPLitude]	(100;-100;100)	Not Confirmed	
:AM		Confirmed	
[:DEPTh]	(50;1;200)	Confirmed	
:INTernal		Confirmed	
:FREQuency	(100;10;500)	Confirmed	
[:EXECute]		Not confirmed	
:PHASe[1]		Confirmed	
:LOCK		Not confirmed	
[:STATe]	OFF ON	Not confirmed	
:NULL		Not confirmed	
:ADJust	(0;0;360)	Confirmed	
:SOuRCe	MASTer SLAVe	Confirmed	
:PHASe2		Confirmed	
:LOCK		Not confirmed	
[:STATe]	OFF ON	Not confirmed	
:ADJust	(0;-180;+180)	Confirmed	
:FINE	(0;-36;+36)	Not Confirmed	
:SEQuence		Not Confirmed	
:ADVance	AUTOMATIC TRIGgered	Not Confirmed	
:DEFine	(1;1;4096),(1;1;4096),(1;1;1E6)	Not Confirmed	Link # = segment, repeat
:DELEte		Not Confirmed	
[:NAME]	(1;1;4096)	Not Confirmed	
:ALL		Not Confirmed	
:RESet		Confirmed	
:SYSTem		Confirmed	
:ERRor?		Confirmed	
:VERsion?		Confirmed	
:TRACe		Confirmed	
[:DATA]		Confirmed	
:DEFine	(1;1;4096),(10;10;64536)	Confirmed	Even number, 64K memory
:DEFine	(1;1;4096),(10;10;523288)	Confirmed	Even number, 512k memory
:DELEte		Confirmed	
[:NAME]	(1;1;4096)	Confirmed	
:ALL		Confirmed	
:SELEct	(1;1;4096)	Confirmed	
:INITiate		Confirmed	
[:IMMediate]		Confirmed	
:CONTinuous	OFF ON	Confirmed	
:TRIGger		Confirmed	
:BURSt		Not Confirmed	
[:STATe]	OFF ON	Not Confirmed	
:COUNt	(1;1;1E6)	Confirmed	
:DELay	(0;10;2E6)	Confirmed	Minimum setting 0 or 10, even number
:LEVEl	(0;-10.00;+10.00)	Confirmed	
:SOuRce		Not Confirmed	
:ADVance	EXTernal INTernal TTLTrg<n>	Not Confirmed	
:GATE		Not Confirmed	
[:STATe]	OFF ON 0 1	Not Confirmed	
:SLOPe	POSitive NEGative	Confirmed	
:TIMer	(100e-6;15e-6;1000)	Confirmed	
[:IMMediate]		Confirmed	
Revised 4/19/00			

Common Commands	Parameter Form (Default in Bold)	IEEE-STD-488.2
:SMEMory		Not Confirmed
:MODE	READ WRITe	Not Confirmed
[:STATe]	OFF ON	Not Confirmed
:TEST		Confirmed
[:ALL]?		Confirmed
*CLS		Confirmed
*ESE	(0;0;255)	Confirmed
*OPC		Confirmed
*RST		Confirmed
*SRE	(0;0;255)	Confirmed
*TRG		Confirmed
*ESE?		Confirmed
*ESR?		Confirmed
*IDN?		Confirmed
*OPC?		Confirmed
*SRE?		Confirmed
*STB?		Confirmed
*TST?		Confirmed

Output Configuration Command Summary

Output Configuration commands control the output function, shape, frequency, amplitude, filter and state. Optional modes are omitted from these commands. Factory defaults after *RST are shown in bold typeface. Parameter low and high limits are given where applicable. Use the Standard Waveform parameters as described in **Using The APPLy Command**.

Commands and Parameters

(Low Limit,High Limit,**Default**)

```
[SOURce:]
  APPLy:SINusoid {<frequency>,[<amplitude>,[<offset>,[<phase>,[<power>]]]]}
  APPLy:TRIangle {<frequency>,[<amplitude>,[<offset>,[<phase>,[<power>]]]]}
  APPLy:SQUare {<frequency>,[<amplitude>,[<offset>,[<duty_cycle>]]]}
  APPLy:PULSe {<frequency>,[<amplitude>,[<offset>,[<delay>,[<high_time>
    ,[<rise_time>,[<fall_time>]]]]]}
  APPLy:RAMP {<frequency>,[<amplitude>,[<offset>,[<delay>,[<rise_time>
    ,[<fall_time>]]]]]}
  APPLy:SINC {<frequency>,[<amplitude>,[<offset>,[<number_cycles>]]]}
  APPLy:EXPonential {<frequency>,[<amplitude>,[<offset>,[<exponent>]]]}
  APPLy:GAUSSian {<frequency>,[<amplitude>,[<offset>,[<exponent>]]]}
  APPLy:DC {<percent_amplitude>}
  APPLy:USER {<segment_number>,[<sampling_clock>,[<amplitude>,[
    <offset>]]]}
  APPLy:<function_shape>?
  APPLy?
  FUNCTio:n:MODE {FIXed | USER | SEQuence} (FIX)
  FUNCTio:n:MODE?
  FUNCTio:n:SHAPE {SINusoid | TRIangle | SQUare | PULSe | RAMP | SINC
    EXPonential | GAUSSian | DC } (SIN)
  FUNCTio:n:SHAPE?
  FREQUency {<frequency> | MINimum | MAXimum} (100E-6,50E6,1E6)
  FREQUency?
  FREQUency:RASTer {<frequency> | MINimum | MAXimum} (100E-3,100E6,1E6)
  FREQUency:RASTer?
  FREQUency:RASTer:SOURce {EXT | INT | ECLtrg0} (INT)
```

SCPI Command Reference 4-8

FREQuency:RASTer:SOURce?	
FREQuency:EXTernal?	
VOLTage {<amplitude> MINimum MAXimum}	(10.0E-3,16.0, 5.00)
VOLTage?	
VOLTage:OFFSet <offset>	(-7.19,7.19, 0)
VOLTage:OFFSet?	
OUTPut:	
FILTer:FREQuency {20MHz 25MHz 50MHz}	20MHz
FILTer:FREQuency?	
FILTer {OFF ON}	OFF
FILTer?	
[STATe] {OFF ON}	OFF
[STATe] SOURce?	
SYNC:SOURce {BIT LCOMplete SSYNc HCLock}	1256K BIT
SYNC:POSition <value>	(0,64K/512K, n-6)
SYNC:SOURce?	
SYNC[:STATe] {OFF ON}	OFF
SYNC[:STATe]?	
ECLTrg<n>{OFF ON}	OFF
TTLTrg<n>{OFF ON}	OFF
TRIGger:SOURce {BIT LCOMplete INTernal External}	BIT

Standard Waveform Command Summary

The Standard Waveform Commands control the various parameters of the standard output functions. Optional modes are omitted from these commands. Factory defaults after *RST are shown in bold typeface. Parameter low and high limits are given where applicable. The Standard Waveforms parameters could be used for the APPLY command.

Command and Parameters	Low Limit	High Limit	Default
[SOURce:]			
SINusoid:PHASe <value>	0	360	0
SINusoid:PHASe?			
SINusoid:POWer <value>	1	9	1
SINusoid:POWer?			
TRlangle:PHASe <value>	0	360	0
TRlangle:PHASe?			
TRlangle:POWer <value>	1	9	1
TRlangle:POWer?			
SQUare:DCYClE <value>	1	99	50
SQUare:DCYClE?			
PULSe:DELay <value>	0	99.9	10.0
PULSe:DELay?			
PULSe:WIDTh <value>	0	99.9	10.0
PULSe:WIDTh?			
PULSe:TRANSition <value>	0	99.9	10.0
PULSe:TRANSition?			
PULSe:TRANSition:TRAILing <value>	0	99.9	10.0
PULSe:TRANSition:TRAILing?			
RAMP:DELay <value>	0	99.9	10.0
RAMP:DELay?			
RAMP:TRANSition <value>	0	99.9	10.0
RAMP:TRANSition?			
RAMP:TRANSition:TRAILing <value>	0	99.9	10.0
RAMP:TRANSition:TRAILing?			
SINC:NCYClE <value>	4	100	10
SINC:NCYClE?			
GAUSSian:EXPOnent <value>	1	200	10
GAUSSian:EXPOnent?			
EXPOnential:EXPOnent <value>	-200	200	-10
EXPOnential:EXPOnent?			
DC <%_amplitude>	-100	100	100
DC?			

Arbitrary Waveform, Sequence, and Shared Memory Command Summary

Arbitrary Waveform commands allow the definition of segments and their corresponding lengths, addition and deletion of segments, and the loading waveform data. Sequence commands control which segments are linked and the number of times each segment is repeated. The shared memory commands place the Model 3152 in a special data transfer mode where the Model 3152's message-based interface is bypassed and data is loaded directly from the VXIbus. Optional modes are omitted from these commands. Defaults are shown in bold.

Command and Parameters

```

TRACe #<binary_block>
TRACe:DEFine {<segment_number>, <length>}
TRACe:DELete <segment_number>
TRACe:DELete:ALL
TRACe:SELect <segment_number>

FORMat:BORDer {NORMal | SWAPped}
FORMat:BORDer?

SEQuence:DEFine <step_number>, <segment_number>, <#_repeat>
SEQuence:DELete <sequence_number>
SEQuence:DELete:ALL
SEQuence:SELect <sequence_number>

SMEMory:MODE {READ | WRITe}
SMEMory {OFF | ON}

```

Modulation Command Summary

The Modulation Commands controls amplitude modulation parameters. Optional modes are omitted from these commands. Factory defaults after *RST are shown in bold typeface. Parameter low and high limits are given where applicable.

Command and Parameters	Low Limit	High Limit	Default
[SOURce:]			
AM <value>	0	200	50
AM?			
AM:INTernal:FREQuency <value>	10	500	100
AM:INTernal:FREQuency?			
AM:EXECute			

Trigger Command Summary

The Trigger commands control the trigger modes of the Model 3152. The Model 3152 can be placed in Triggered, Gated or Burst mode. Trigger source is selectable from an external source, internal trigger generator, backplane TTLTrg 0-7, and software trigger. Optional modes are omitted from these commands. Factory defaults after *RST are shown in bold typeface. Parameter low and high limits are given where applicable.

Command and Parameters	Low Limit	High Limit	Default
INITiate:CONTInuous {OFF ON}			ON
TRIGger:BURSt {OFF ON}			OFF
TRIGger:COUNt <value>	1	1e6	1
TRIGger:DELay <value>	0/10	2e6	0
TRIGger:DELay:STATe {OFF ON}			OFF
TRIGger:GATE {OFF ON}			OFF
TRIGger:LEVel <value>	-10	10	1.6
TRIGger:SLOPe {POSitive NEGative}			POS
TRIGger:SOURce:ADVance {EXTernal INTernal TTLTrg<n>}			EXT
TRIGger:TIMer: <value>	15e-6	1000	100e-6
TRIGger:IMMEDIATE			
*TRG			

Backplane Inter-Module Phase Synchronization Command Summary

Phase Synchronization commands control the phase offset between two or more modules. There is no limit on how many modules can be synchronized, as long as one module is programmed to be master and the rest of the modules are slaves. The location of the slave modules in relation to the master module does not affect the accuracy of the phase offset.

The commands are presented exactly as they should be typed in your program. Optional nodes were omitted from these commands. Factory defaults after *RST or front panel reset are shown in **bold typeface**. Parameter low and high limits are given where applicable.

Command and Parameters	Low Limit	High Limit	Default
PHASe:LOCK {OFF ON}			OFF
PHASe:ADJust <value>	0	360 (*)	0
PHASe:SOURce {MASTer SLAVe}			SLAV
PHASe:NULL			

(*) High phase offset limit is not always 360°. It depends on the number of points that were assigned to the active memory segment. Phase offset limits are specified in **Appendix A**.

Front-Panel PLL Command Summary

Front-panel PLL commands control the PLL mode and the phase offsets with respect to an external reference. If the Model 3152 is placed in PLL mode, it can be used as a slave only. After lock, the synthesizer's output frequency is exactly equal to the frequency of the reference signal.

Revised 4/19/00

The commands are presented exactly as they should be typed in your program. Optional nodes were omitted from these commands. Factory defaults after *RST or front panel reset are shown in bold typeface. Parameter low and high limits are given where applicable.

Command and Parameters	Low Limit	High Limit	Default
PHAS2:LOCK {OFF ON}			OFF
PHAS2:ADJust <value>	-180	180	0
PHAS2:FINE <value>	-36.00	36.00	0

PHAS2:FINE adjustment is always relative to the PHAS2:ADJ setting. For instance, Programming PHAS2:ADJ 120 and PHAS2:FINE -1.55 will generate a phase offset of 118.45 degrees. Note that the PLL lock range depends on the number of waveform samples, sampling frequency and external reference frequency. The relationship between these parameters is show in **Appendix A**.

System-Related Command Summary

The system-related commands are not related directly to waveform generation but are an important part of operating the Model 3152. These commands can reset or test the instrument, or query the instrument for system information.

Command and Parameters

SYSTem:ERRor?
 SYSTem:VERSion?
 RESet
 *RST
 TEST?
 *TST?
 *IDN?
 *OPT?

IEEE-STD-488.2 Common Commands and Queries

Since most instruments and devices in an ATE system use similar commands which perform similar functions, the IEEE-STD-488.2 document has specified a common set of commands and queries which all compatible devices must use. This avoids situations where devices from various manufacturers use different sets of commands to enable functions and report status. The IEEE-STD-488.2 treats common commands and queries as device dependent commands. For example, *TRG is sent over the bus to trigger the instrument. Some common commands and queries are optional, but most of them are mandatory.

The following is a complete listing of all common commands and queries which are used in the Model 3152.

***CLS** - Clear the Status Byte summary register and all event registers.

***ESE <enable_value>** - Enable bits in the Standard Event enable register. The selected bits are then reported to the status byte.

***ESE?** - Query the Standard Event enable register. The synthesizer returns a decimal value which corresponds to the binary-weighted sum of all bits set in the register.

***ESR?** - Query the Standard Event register. The synthesizer returns a decimal value which corresponds to the binary-weighted sum of all bits set in the register.

***IDN?** - Query the synthesizer's identity. The returned data is organized into four fields, separated by commas. The synthesizer responds with its manufacturer and model number in the first two fields, and may also report its serial number and options in fields three and four. If the latter information is not available, the device must return an ASCII 0 for each. For example, Model 3152's response to *IDN? is:

RACAL INSTRUMENTS,3152,0,1.0.

***OPC** - Set the "operation complete" bit (bit 0) in the Standard Event register after the previous commands have been executed.

***OPC?** - Returns "1" to the output buffer after all the previous commands have been executed. *OPC? is used for synchronization between a controller and the instrument using the MAV bit in the Status Byte or a read of the Output Queue. The *OPC? query does not affect the OPC Event bit in the Standard Event Status Register (ESR). Reading the response to the ***OPC?** query has the advantage of removing the complication of dealing with service requests and multiple polls to the instrument. However, both the system bus and the controller handshake are in a temporary hold-off state while the controller is waiting to read the *OPC? query response.

***OPT?** - Returns the value "0" for Model 3152 with 64K memory. Returns "1" for Model 3152 with 256K memory or with 512K memory.

***RST** - Resets the synthesizer to its default state. Default values are listed in **Table 4-1**.

***SRE <enable_value>** - Enables bits in the Status Byte enable register.

***SRE?** - Query the Status Byte enable register. The synthesizer returns a decimal value in the range of 0 to 63 or 128 to 191 since bit 6 (RSQ) cannot be set. The binary-weighted sum of the number represents the value of the bits of the Service Request enable register.

***STB?** - Query the Status Byte summary register. The ***STB?** command is similar to a serial poll but is processed like any other instrument command. The ***STB?** command returns the same result as a serial poll, but the "request service" bit (bit 6) is not cleared if a serial poll has occurred.

***TRG** - Triggers the synthesizer from the remote interface. This command effects the synthesizer if it is first placed in the Trigger or Burst mode of operation and the trigger source is set to "BUS".

***TST?** - Implements an internal self-test and returns a value as described below. Approximately 90% of the Model 3152 functionality is tested.

- 0 - Self-test passed
- 1 - DAC, DAC control, output amplifier or amplitude control failure.
- 2 - Offset amplifier or offset control failure
- 4 - CPU to peripheral communication failure
- 8 - Trigger circuit or internal trigger failure
- 16 - Sequence or burst generator failure
- 32 - Clock generator failure

More than one failure can be reported at one time. For example, the returned value "17" indicates both a DAC/Output Amplifier problem and a sequence/burst generator problem exist.

***WAI** - Wait for all pending operations to complete before executing any additional commands over the interface.

The SCPI Status Registers

The Model 3152 uses the Status Byte register group and the Standard Event register group to record various instrument conditions. **Figure 4-1** shows the SCPI status system.

An Event Register is a read-only register that reports defined conditions within the synthesizer. Bits in an event register are latched. When an event bit is set, subsequent state changes are ignored. Bits in an event register are automatically cleared by a query of that register or by sending the ***CLS** command. The ***RST** command or device clear does not clear bits in an event register. Querying an event register returns a decimal value which corresponds to the binary-weighted sum of all bits set in the register.

An Event Register defines which bits in the corresponding event register are logically ORed together to form a single summary bit. The user can read from and write to an Enable Register. Querying an Enable Register will not clear it. The *CLS command does not clear Enable Registers but it does clear bits in the event registers. To enable bits in an enable register, write a decimal value that corresponds to the binary-weighted sum of the bits required to enable in the register.

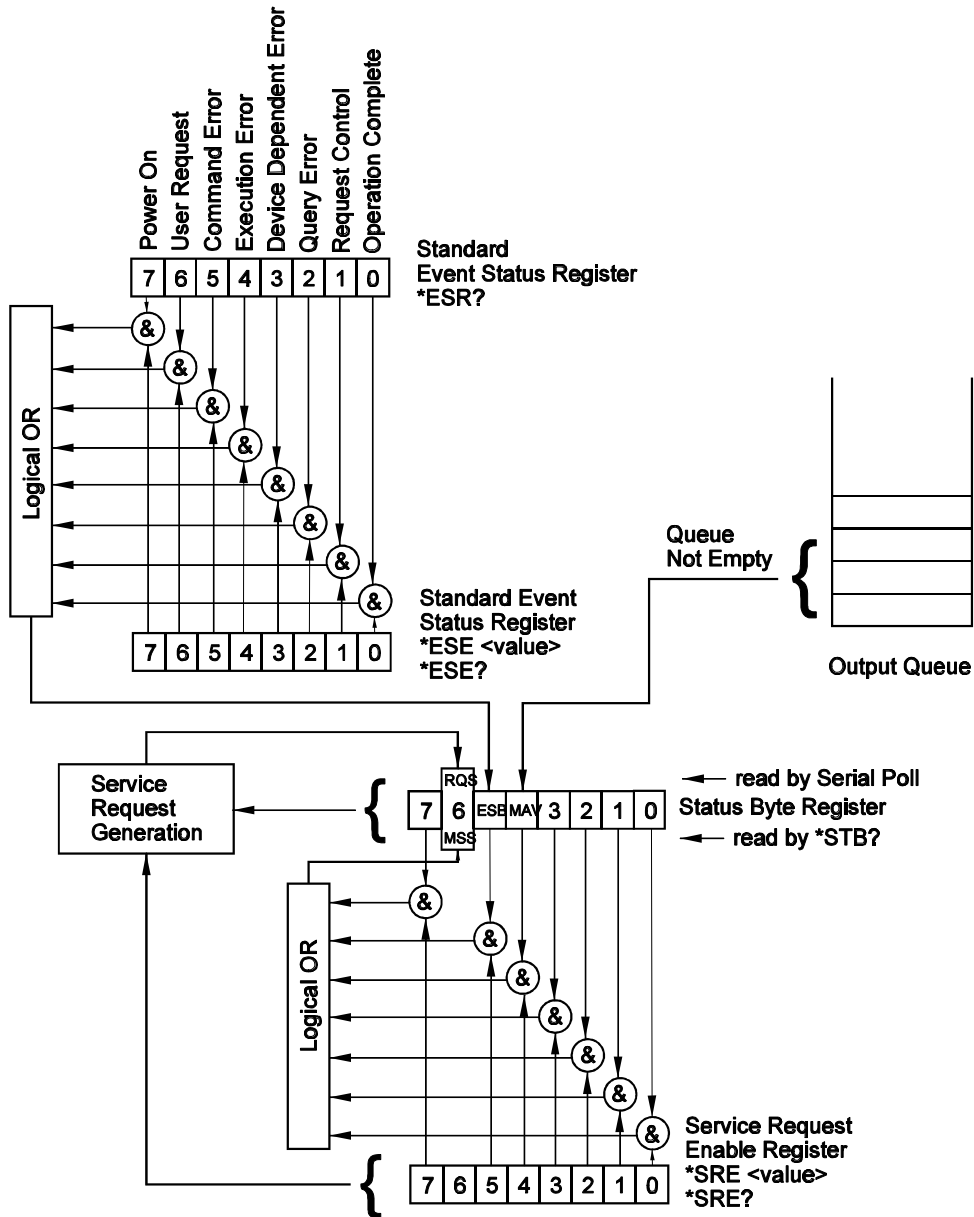

Figure 4-1 SCPI Status Registers

The Status Byte Register (STB)

The Status Byte summary register contains conditions from the other registers. Query data waiting in the synthesizer's output buffer is immediately reported through the Message Available bit (bit 4). Bits in the summary register are not latched. Clearing an event register will clear the corresponding bits in the Status Byte summary register. Description of the various bits within the Status Byte summary register is given in the following:

Bit 0 - Decimal value 1. Not used, always set to 0.

Bit 1 - Decimal value 2. Not used, always set to 0.

Bit 2 - Decimal value 4. Not used, always set to 0.

Bit 3 - Decimal value 8. Not used, always set to 0.

Bit 4 - Decimal value 16. Message Available Queue Summary Message (MAV). The state of this bit indicates whether or not the output queue is empty. The MAV summary message is true when the output queue is not empty. This message is used to synchronize information exchange with the controller. The controller can, for example, send a query command to the device and then wait for MAV to become true. If an application program begins a read operation of the output queue without first checking for MAV, all system bus activity is held up until the device responds.

Bit 5 - Decimal value 32. Standard Event Status Bit (ESB) Summary Message. This bit indicates whether or not one or more of the enabled ESB events have occurred since the last reading or clearing of the Standard Event Status Register.

Bit 6 - Decimal value 64. Master Summary Status (MSS)/Request Service (RQS) Bit. This bit indicates if the device has at least one condition to request service. The MSS bit is not part of the IEEE-STD-488.1 status byte and will not be sent in response to a serial poll. However, the RQS bit, if set, will be sent in response to a serial poll.

Bit 7 - Decimal value 128. Not used, always set to 0.

Reading the Status Byte Register

The Status Byte summary register can be read with the *STB? common query. The *STB? common query causes the synthesizer to send the contents of the Status Byte register and the MSS (Master Summary Status) summary message as a single <NR1 Numeric Response Message> element. The response represents the sum of the binary-weighted values of the Status Byte Register. The *STB? common query does not alter the status byte.

Clearing the Status Byte Register

The entire Status Byte register can be cleared by removing the reasons for service from Auxiliary Status registers. Sending the *CLS command to the device after a SCPI command terminator and before a Query clears the Standard Event Status Register and clears the output queue of any unread messages. With the output queue empty, the MAV summary message is set to FALSE. Methods of clearing other auxiliary status registers are discussed in the following paragraphs.

Service Request Enable Register (SRE)

The Service Request enable register is an 8-bit register that enables corresponding summary messages in the Status Byte Register. Thus, the application programmer can select reasons for the synthesizer to issue a service request by altering the contents of the Service Request Enable Register.

The Service Request Enable Register is read with the *SRE? common query. The response to this query is a number that represents the sum of the binary-weighted value of the Service Request Enable Register. The value of the unused bit 6 is always zero.

The Service Request Enable Register is written using the *SRE command followed by a decimal value representing the bit values of the Register. A bit value of 1 indicates an enabled condition. Consequently, a bit value of zero indicates a disabled condition. The Service Request Enable Register is cleared by sending *SRE0. The synthesizer always ignores the value of bit 6. Summary of *SRE commands is given in the following.

***SRE0** - Clears all bits in the register.

***SRE1** - Not used.

***SRE2** - Not used.

***SRE4** - Not used.

***SRE8** - Not used.

***SRE16** - Service request on MAV.

***SRE32** - Service request on ESB summary bit.

***SRE128** - Not used.

Standard Event Status Register (ESR)

The Standard Event Status Register reports status for special applications. The 8 bits of the ESR have been defined by the IEEE-STD-488.2 as specific conditions which can be monitored and reported back to the user upon request. The Standard Event Status Register is destructively read with the *ESR? common query. The Standard Event Status Register is cleared with a *CLS common command, with a power-on and when read by *ESR?.

The arrangement of the various bits within the register is firm and is required by all GPIB instruments that implement the IEEE-STD-488.2. Description of the various bits is given in the following:

Bit 0 - Operation Complete. Generated in response to the *OPC command. It indicates that the device has completed all selected and pending operations and is ready for a new command.

Bit 1 - Request Control. This bit operation is disabled on the Model 3152.

Bit 2 - Query Error. This bit indicates that an attempt is being made to read data from the output queue when no output is either present or pending.

Bit 3 - Device Dependent Error. This bit is set when an error in a device function occurs. For example, the following command will cause a DDE error:

```
VOLTage 7.25;:VOLTage:OFFSet 4.1
```

Both of the above parameters are legal and within the specified limits, however, the synthesizer is unable to generate such an amplitude and offset combination.

Bit 4 - Execution Error. This bit is generated if the parameter following the command is outside of the legal input range of the synthesizer.

Bit 5 - Command Error. This bit indicates the synthesizer received a command that was a syntax error or a command that the device does not implement.

Bit 6 - User Request. This event bit indicates that one of a set of local controls had been activated. This event bit occurs regardless of the remote or local state of the device.

Bit 7 - Power On. This bit indicates that the device's power source was cycled since the last time the register was read.

Standard Event Status Enable Register (ESE)

The Standard Event Status Enable Register allows one or more events in the Standard Event Status Register to be reflected in the ESB summary message bit. The Standard Event Status Enable Register is an 8-bit register that enables corresponding summary messages in the Standard Event Status Register. Thus, the application programmer can select reasons for the synthesizer to issue an ESB summary message bit by altering the contents of the ESE Register.

The Standard Event Status Enable Register is read with the *ESE? common query. The response to this query is a number that represents the sum of the binary-weighted value of the Standard Event Status Enable Register.

The Standard Event Status Enable Register is written using the *ESE command followed by a decimal value representing the bit values of the Register. A bit value one indicates an enabled condition. Consequently, a bit value of zero indicates a disabled condition. The Standard Event Status Enable Register is cleared by setting *ESE0. Summary of *ESE messages is given in the following.

***ESE0** - No mask. Clears all bits in the register.

***ESE1** - ESB on Operation Complete.

***ESE2** - ESB on Request Control.

***ESE4** - ESB on Query Error.

***ESE8** - ESB on Device Dependent Error.

***ESE16** - ESB on Execution Error.

***ESE32** - ESB on Command Error.

***ESE64** - ESB on User Request.

***ESE128** - ESB Power on.

Error Messages

In general, whenever the Model 3152 receives an invalid SCPI command, it automatically generates an error. Errors are stored in a special error queue and may be retrieved from this buffer one at a time. Errors are retrieved in first-in-first-out (FIFO) order. The first error returned is the first error that was stored. When you have read all errors from the queue, the synthesizer responds with a 0, "No error" message.

If more than 30 errors have occurred, the last error stored in the queue is replaced with -350, "Too many errors". No additional errors are stored until you remove errors from the queue. If no errors have occurred when you read the error queue, the synthesizer responds with 0, "No error".

The error queue is cleared when power has been shut off or after a *CLS command has been executed. The *RST command does not clear the error queue. Use the following command to read the error queue:

```
SYSTem:ERRor?
```

Errors have the following format (the error string may contain up to 80 characters):

```
-102,"Syntax error"
```

A complete listing of the errors that can be detected by the synthesizer is given below.

-100,"Command error". When the synthesizer cannot detect more specific errors, this is the generic syntax error used.

-101,"Invalid Character". A syntactic element contains a character which is invalid for that type.

-102,"Syntax error". Invalid syntax found in the command string.

-103,"Invalid separator". An invalid separator was found in the command string. A comma may have been used instead of a colon or a semicolon. In some cases where the synthesizer cannot detect a specific separator, it may return error -100 instead of this error.

-104,"Data type error". The parser recognized a data element different than allowed.

-108,"Parameter not allowed". More parameters were received than expected for the header.

-109,"Missing parameter". Too few parameters were received for the command. One or more parameters that were required for the command were omitted.

-128,"Numeric data not allowed". A legal numeric data element was received, but the instrument does not accept one in this position.

-131,"Invalid suffix". A suffix was incorrectly specified for a numeric parameter. The suffix may have been misspelled.

-148,"Character data not allowed". A character data element was encountered where prohibited by the instrument.

-200,"Execution error". This is the generic syntax error for the instrument when it cannot detect more specific errors. Execution error as defined in IEEE-488.2 has occurred.

-221,"Setting conflict". Two conflicting parameters were received which cannot be executed without generating an error. An offset value which is outside the amplitude level window may have been sent.

-222,"Data out of range". Parameter data which followed a specific header could not be used because its value is outside the valid range defined by the synthesizer.

224,"Illegal parameter value". A discrete parameter was received which was not a valid choice for the command. An invalid parameter choice may have been used.

-300,"Device-specific-error". This is the generic device-dependent error for the instrument when it cannot detect more specific errors. A device-specific error as defined in IEEE-488.2 has occurred.

-311,"Memory error". Indicates that an error was detected in the instrument's memory.

-350,"Too many errors". The error queue is full because more than 30 errors have occurred. No additional errors are stored until the errors from the queue are removed. The error queue is cleared when power has been shut off, or after a *CLS command has been executed.

-410,"Query INTERRUPTED". A command was received which sends data to the output buffer, but the output buffer contained data from a previous command (the previous data is not overwritten). The output buffer is cleared when power is shut off or after a device clear has been executed.

Device-Specific Commands

The Model 3152 conforms to the 1993.0 version of the SCPI standard. Some of the commands used are not included in the 1993.0 version. However, these commands are designed with the SCPI standard in mind and they follow all of the command syntax rules defined by the standard. **Table 4-1** lists all device-specific commands that were designed specifically for the Model 3152 as not confirmed SCPI 1993.0 commands.

Maintenance and Performance Checks

What's in This Chapter

This chapter provides maintenance, service information, performance tests, and the information necessary to adjust and troubleshoot the Model 3152 Waveform Synthesizer.

WARNING

The procedures described in this section are for use only by qualified service personnel. Many of the steps covered in this section may expose the individual to potentially lethal voltages that could result in personal injury or death if normal safety precautions are not observed



CAUTION

ALWAYS PERFORM DISASSEMBLY, REPAIR AND CLEANING AT A STATIC SAFE WORKSTATION.

Disassembly Instructions

If it is necessary to troubleshoot the instrument or replace a component, use the following procedure to remove the side panels:

1. Using a Phillips head screw driver, remove the two screws on each side of the instrument, and one screw at the rear of the instrument that secures the side panels.
2. Grasp one side panel and carefully slide and lift it off the instrument. Use the same procedure to remove the other side panel. After removing the side panels from the instrument, access the component side for calibration and checks, and the solder side when replacing components.
3. When replacing the side panels, reverse the above procedure.

Special Handling of Static Sensitive Devices

MOS devices are designed to operate at very high impedance levels for low power consumption. As a result, any normal static charge that builds up on your person or clothing may be sufficient to destroy these devices if they are not handled properly. When handling such devices, use precaution to avoid damaging them as described below:

1. MOS IC's should be transported and handled only in containers specially designed to prevent static build-up. Typically, these parts are received in static-protected containers of plastic or foam. Keep these devices in their original containers until ready for installation.
2. Ground yourself with a suitable wrist strap. Remove the devices from the protective containers only at a properly grounded work station.
3. Remove a device by grasping the body; do not touch the pins
4. Any printed circuit board into which the device is to be inserted must also be grounded to the bench or table.
5. Use only anti-static type solder suckers.
6. Use only grounded soldering irons.
7. Once the device is installed on the PC board, the device is adequately protected and normal handling may resume.

Cleaning

The Model 3152 should be cleaned as often as operating conditions require. To clean the instrument, use the following procedure:

1. Thoroughly clean the inside and outside of the instrument.
2. When cleaning inaccessible areas, remove dust with low pressure compressed air or a vacuum cleaner.
3. Use alcohol applied with a cleaning brush to remove accumulation of dirt or grease from connector contacts and component terminals.
4. Clean the exterior of the instrument and the front panel with a mild detergent mixed with water, applying the solution with a soft, lint-free cloth.

Repair and Replacement

Repair and replacement of electrical and mechanical parts must be accomplished with great care and caution. Printed circuit boards can become warped, cracked or burnt from excessive heat or mechanical stress. The following repair techniques are suggested to avoid inadvertent destruction or degradation of parts and assemblies:

1. Use a 60/40 solder and temperature-controlled 35 - 40 watt pencil-type soldering iron on the circuit board. The tip of the iron should be clean and properly tinned for best heat transfer to the solder joint. A higher wattage soldering iron may separate the circuit from the base material.

Maintenance and Performance Checks 5-2

2. Keep the soldering iron in contact with the PC board for a minimum time to avoid damage to the components or printed conductors.
3. To desolder components, use a commercial "solder sucker" or a solder-removing SOLDER - WICK, size 3.
4. Always replace a component with an exact duplicate as specified in the parts list.

Performance Checks

The following performance checks verify proper operation of the instrument and should normally be used:

1. As a part of the incoming inspection of the instrument specifications;
2. As part of the troubleshooting procedure;
3. After any repair or adjustment before returning the instrument to regular service.

Environmental Conditions

Tests should be performed under laboratory conditions having an ambient temperature of $25^{\circ}\text{C} \pm 5^{\circ}\text{C}$ and at relative humidity of less than 80%. If the instrument has been subjected to conditions outside these ranges, allow at least one additional hour for the instrument to stabilize before beginning the adjustment procedure. Always perform a self-test sequence before commencing with the performance checks. The self-test, if executed without any failure, ensures proper operation of the synthesizer. If self-test failures have been encountered, the instrument first needs to be serviced and the source of failure removed. Instructions on how to perform self-test is given later in this chapter in the **Self-Test** section.

Warm-Up Period

Most equipment is subject to a small amount of drift when it is first turned on. To ensure accuracy, turn on the power to the Model 3152 and allow it to warm-up for at least 30 minutes before beginning the performance test procedure.

Initial Instrument Setting

To avoid confusion as to which initial setting is to be used for each test, it is required that the instrument be reset to factory default values prior to each test. To reset the Model 3152 to factory defaults, send either of the following commands:

RESet, or *RST.

Recommended Test Equipment

Recommended test equipment for troubleshooting, calibration and performance checking is listed below. Test instruments other than those listed may be used only if their specifications equal or exceed the required characteristics.

Test Instrument & Accessories	Minimum Specification
Universal Counter	100 MHz, 10 ppm accuracy
DMM	ACV, 0.2%; DCV, 0.1% accuracy
Distortion Analyzer	10 Hz to 100 KHz
Spectrum Analyzer	1 GHz bandwidth, 1 KHz resolution
Pulse/Function Generator	20 MHz, 10 ns pulsewidth
Oscilloscope	2 channels, 400 MHz analog bandwidth
Feedthrough termination	50Ω, 1%
BNC Cables	1 meter long, 50Ω impedance
20dB feedthrough attenuator	50Ω, 1%
"T" BNC Connector	50Ω, 1%

Performance Check Procedures

Use the following procedures to check the Model 3152 against the specifications. A complete set of specifications is listed in Appendix A. The following paragraphs show how to set up the instrument for the test, what the specifications for the tested function are, and what acceptable limits for the test are. If the instrument fails to perform within the specified limits, the instrument has to be calibrated or tested to find the source of the problem.

Frequency Accuracy

Accuracy Specifications: 0.01% of reading to 50.00 MHz

Equipment: Counter

1. Configure the Model 3152 as follows:

Function: Square
Frequency: 10 Hz
Amplitude: 1 V
Remote Commands: :RES
:OUTP ON
:FUNC:SHAP SQU
:FREQ 10
:VOLT 1

2. Set the counter to frequency measurement.

- Connect the Model 3152 output to the counter's input. Change the frequency setting as required for the test and verify the reading on the counter display as follows:

3152 SETTING	COUNTER READING
10.00000 Hz	9.999000 Hz - 10.00100 Hz
100.0000 Hz	99.99000 Hz - 100.0100 Hz
1.000000 KHz	999.9000 Hz - 1.000100 KHz
10.00000 KHz	9.999000 KHz - 10.00100 KHz
100.0000 KHz	99.99000 KHz - 100.0100 KHz
1.000000 MHz	999.9000 KHz - 1.000100 MHz
10.00000 MHz	9.999000 MHz - 10.00100 MHz
50.00000 MHz	49.99500 MHz - 50.00500 MHz

Amplitude Accuracy

Accuracy Specifications (1 KHz):

- $\pm(1\% \text{ of reading} + 200 \mu\text{V})$, to 160 mV
- $\pm(1\% \text{ of reading} + 2 \text{ mV})$, to 1.6 V
- $\pm(1\% \text{ of reading} + 20 \text{ mV})$, to 16 V

Equipment: DMM, 50 Ω feedthrough termination

- Configure the Model 3152 as follows:

```

Function:          Sine
Frequency:         1.000 KHz
Amplitude:         15 V
Remote Commands:  :RES
                  :OUTP ON
                  :FUNC:SHAP SIN
                  :FREQ 1000
                  :VOLT 15

```

- Set the DMM to ACV measurements (RMS).
- Connect the Model 3152 output to DMM input. Terminate the output with a 50 Ω feedthrough termination. Set the amplitude and verify DMM reading as follows:

3152 SETTING	DMM READING
15.00 V	5.373 V - 5.230 V
1.500 V	537.3 mV - 523.0 mV
150.0 mV	53.73 mV - 52.30 mV

DC Offset Characteristics

Accuracy Specifications:

- $\pm(1\% \text{ of reading} + 1\% \text{ of amplitude} + 200 \mu\text{V})$, $\pm 80 \text{ mV}$ window
- $\pm(1\% \text{ of reading} + 1\% \text{ of amplitude} + 2 \text{ mV})$, $\pm 800 \text{ mV}$ window
- $\pm(1\% \text{ of reading} + 1\% \text{ of amplitude} + 20 \text{ mV})$, $\pm 8 \text{ V}$ window

Equipment: DMM, 50Ω feedthrough termination

1. Configure the Model 3152 as follows:

Function: Sine
Frequency: 1.000 MHz
Amplitude: 1.61 V
Remote Commands: :RES
:OUTP ON
:FUNC SIN
:FREQ 1e6
:VOLT 1.61
:VOLT:OFFS 5

2. Set the DMM to DCV measurements
3. Connect the Model 3152 output to the DMM input. Terminate the output with a 50Ω feedthrough termination. Set the Model 3152 offset and verify the DMM reading as follows:

OFFS SETTING	DMM READING
±5.000 V	±5.070 V to ±4.930 V

4. Change the Model 3152 AMPL setting to 161 mV. Set VOLT:OFFS and verify the DMM reading as follows:

OFFS SETTING	DMM READING
±500.0 mV	±507.0 mV to ±493.0 mV

5. Change the Model 3152 AMPL setting to 16.1 mV. Set VOLT:OFFS and verify the DMM reading as follows:

OFFS SETTING	DMM READING
±50.00 mV	±50.70 mV to ±49.30 mV

Squarewave Characteristics

Specified Transition Time: 5 ns typical (10% to 90% of amplitude)

Specified Aberration: <5% of amplitude

Equipment: Oscilloscope, 20dB attenuator

1. Configure the Model 3152 as follows:

Function: Square wave
Frequency: 1.000 MHz
Amplitude: 10 V
Remote Commands: :RES
:OUTP ON
:FUNC:SHAP SQU
:FREQ 10e6
:VOLT 10

Maintenance and Performance Checks 5-6

2. Connect the Model 3152 output to the oscilloscope input. Use the 20 dB attenuator and set the oscilloscope input impedance to 50Ω.
3. Set the oscilloscope and verify that the rise and fall times are less than 6 ns. Verify that overshoot and ringing are less than 5% of amplitude.

Sine Characteristics

Specified Total Harmonic Distortion: <0.1% from 10.00Hz to 100.0KHz (with a 4000 point waveform).

Specified Harmonic Signals:

<5MHz, ≤10Vp-p, -50dBc
 <5MHz, ≤16Vp-p, -45dBc
 <10MHz, ≤10Vp-p, -40dBc
 <10MHz, ≤16Vp-p, -35dBc
 <50MHz, ≤10Vp-p, -28dBc
 <50MHz, ≤16Vp-p, -23dBc

Equipment: Krohn-Hite 6900 (or equivalent) Distortion Analyzer, RF Spectrum Analyzer, 50Ω feedthrough termination (or 20dB 50Ω attenuator if required).

1. Connect the Model 3151 output to distortion analyzer input.
2. Set the distortion analyzer to distortion measurements, set the Model 3151 frequency setting, and verify the distortion reading as below.
3. Configure the Model 3151 as follows:

```
Function:          USER Waveform
Frequency:        10.00Hz
Amplitude:        5V
Remote Commands  : :RES
                  :OUTP ON
                  :FUNC:MODE USER
                  :TRAC:DEF 4000
                  :TRAC:SEL 1
                  :FREQ:RAST 40e3
                  :VOLT5
```

Using WaveCAD, change the axis (Setup | Axis) to have 4000 points (0 to 3999) for the first 4 steps below and 1000 points (0 to 999) for step 5 below. Download a 1k or 4k sine waveform (Wave | Sine | OK) into segment 1.

FREQ:RAST	# of Points	Frequency	Distortion Reading
40e3	4000	10Hz	< 0.1%
40e4	4000	100Hz	< 0.1%
40e5	4000	1kHz	< 0.1%
40e6	4000	10kHz	< 0.1%
100e6	1000	100kHz	< 0.1%

Maintenance and Performance Checks 5-7

Revised 7/25/00

4. Tune the spectrum analyzer to the carrier frequency and adjust the gain so the fundamental corresponds to 0 dB.
5. Connect the Model 3152 output to spectrum analyzer input through a 20dB feedthrough attenuator.
6. Set the Model 3152 FREQ setting and verify the harmonic distortions levels as follows:

FREQ SETTING	HARMONICS LEVEL
5.000 MHz	<50 dB
50.00 MHz	<28 dB

Sine Flatness

Level Flatness: $\pm 1\%$ to 1.000 MHz; $\pm 5\%$ to 10.00 MHz; $\pm 15\%$ to 50.00 MHz

Equipment: Oscilloscope

1. Configure the Model 3152 as follows:

Function:	Sine wave
Frequency:	1.000 KHz
Amplitude:	6 V
Remote Commands:	:RES :OUTP ON :FREQ 10e3 :VOLT 6
2. Connect the Model 3152 OUTPUT to the oscilloscope, set the oscilloscope input impedance to 50Ω , and set the oscilloscope to display the sinewave within exactly 6 vertical divisions.
3. Change the Model 3152 FREQ setting to 1.000 MHz. Verify that peak-to-peak of the displayed sinewave is within 5.9 to 6.1 divisions.
4. Change the Model 3152 FREQ setting to 10.00 MHz. Verify that peak-to-peak of the displayed sinewave is within 5.7 to 6.3 divisions.
5. Change the Model 3152 FREQ setting to 50.00 MHz. Verify that peak-to-peak of the displayed sinewave is within 5.1 to 6.9 divisions.

Trig, Gate and Burst Characteristics

Triggered - Each transition at the front panel TRIG IN connector stimulates the Model 3152 to generate one complete output waveform.

Maintenance and Performance Checks 5-8

Gated - External signal at the TRIG IN connector enables the Model 3152 output. The last cycle of the output waveform is always completed.

Burst - Each transition at the front panel TRIG IN connector stimulates the Model 3152 to generate a burst of pre-selected number of cycles.

Equipment: Pulse/function generator (8021), oscilloscope.

Trigger

1. Configure the Model 3152 as follows:

Function:	Sine wave
Frequency:	1.000 MHz
Operating Mode:	Triggered
Remote Commands:	:RES
	:OUTP ON
	:FREQ 1e6
	:INIT:CONT OFF
2. Set the external pulse/function generator frequency to 10 KHz and connect its SYNC connector. Set the oscilloscope and verify on the oscilloscope that the Model 3152 outputs a triggered signal. Leave the external pulse generator connected to the Model 3152 for the next test.

Gate

1. Configure the Model 3152 as follows:

Function:	Sine wave
Frequency:	1.000 KHz
Operating Mode:	Gated
Remote Commands:	:RES
	:OUTP ON
	:FREQ 1e3
	:INIT:CONT OFF
	:GATE:STAT ON
2. Set the oscilloscope and verify that the Model 3152 outputs a gated signal. Leave the external pulse generator connected to the Model 3152 for the next test.

Burst

1. Configure the Model 3152 as follows:

Function:	Sine wave
Frequency:	1.000 KHz
Operating Mode:	Burst
Remote Commands:	:RES
	:OUTP ON
	:FREQ 10e3
	:INIT:CONT OFF
	:BURST:STAT ON
	:TRIG:COUN 10
2. Set the oscilloscope and verify that the Model 3152 outputs a burst of 10 complete output waveforms. Remove the external pulse generator connection from the Model 3152 for the next test.

PLL Characteristics

Accuracy: $5.4 \times \text{frequency (in MHz)} + \text{resolution} / 2 \pm 5^\circ$

Equipment: Oscilloscope, Counter, Pulse/Function Generator, Feedthrough Terminator, 3 BNC Cables, 50Ω "T" Connector

1. Configure the Model 3152 as follows:

Function:	Square wave
Mode:	Front Panel PLL
Frequency:	1.000 KHz
Amplitude:	2 V
Trigger Level:	0 V
Remote Commands:	:RES
	:OUTP ON
	:FUNC:SHAP SQU
	:PHAS2:LOCK ON
	:TRIG:LEV 0
	:VOLT 2
2. Make the following connections:
 - a. Connect function generator output to the input of the 50Ω "T" Connector.
 - b. Connect one end of the 50Ω "T" Connector to the 3152 TRIG IN and the other end to the counter Channel A input.
 - c. Connect 3152 OUT to the counter Channel B input.
3. Set counter to phase measurements. Terminate counter inputs with 50Ω.

Maintenance and Performance Checks 5-10

4. Set Pulse/Function generator to output 2 Vp-p square waveforms. Change 3152 and Pulse/Function generator frequency and verify counter phase readings as shown below.

3152 FREQ. SETTING	PULSE GENERATOR	
	FREQ. SETTING	COUNTER READING
10.00 MHz	10.00 MHz	0° ±77°
1.000 MHz	1.000 MHz	0° ±12.2°
100.0 KHz	100.0 KHz	0° ±5.72°
10.00 KHz	10.00 KHz	0° ±5°

5. Change the Model 3152 PHAS2:ADJ setting to 180°. Change 3152 and Pulse/Function generator frequency and verify counter phase readings as shown below.

3152 FREQ. SETTING	PULSE GENERATOR	
	FREQ. SETTING	COUNTER READING
10.00 KHz	10.00 KHz	180° ±5°

6. Change the Model 3152 PHAS2:ADJ setting to -180°. Change 3152 and Pulse/Function generator frequency and verify counter phase readings as shown below.

3152 FREQ. SETTING	PULSE GENERATOR	
	FREQ. SETTING	COUNTER READING
10.00 KHz	10.00 KHz	-180° ±5°

7. Change the Model 3152 PHAS2:ADJ setting to 0°. Change 3152 and Pulse/Function generator frequency and verify counter phase readings as shown below. Note the exact phase reading.

3152 FREQ. SETTING	PULSE GENERATOR	
	FREQ. SETTING	COUNTER READING
10.00 KHz record	10.00 KHz	0° ±5° (Note and the exact reading)

8. Change the Model 3152 PHAS2:ADJ setting to 0° and PHAS2:FINE setting to 36°. Verify counter phase readings as shown below. Note the exact phase reading.

3152 FREQ. SETTING	PULSE GENERATOR FREQ. SETTING	COUNTER READING
10.00 KHz	10.00 KHz	Recorded result from step 7 +36° ±0.36°

Adjustments

Environmental Conditions

Adjustments should be performed under laboratory conditions having an ambient temperature of 24°C ±2°C and relative humidity of less than 70%. If the instrument has been outside this range, allow at least one additional hour for the instrument to stabilize before beginning the adjustment procedure. Between adjustments, always leave the top cover on the unit to keep the internal temperature as stable as possible.

Warm-Up Period

Most equipment is subject to a small amount of drift when first turned on. To ensure long term calibration accuracy, turn on the power to the Model 3152 and allow it to warm-up for at least 30 minutes before beginning the adjustment procedure.

Recommended Test Equipment

Recommended test equipment for calibration is listed at the beginning of this chapter in the section entitled **Recommended Test Equipment**. Test instruments other than those listed may be used only if their specifications equal or exceed the required characteristics.

Adjustment Procedures

All adjustments are performed with the POWER ON. The side covers should be removed to allow access to test points and adjustments.

Special care should be taken to prevent contact with live circuits or the power line area. This could cause an electrical shock resulting in serious injury or death. Use an isolated tool when making adjustments.

When necessary, refer to the component layouts for determining adjustment points. Follow the procedure in the sequence indicated as some adjustments are interrelated and dependent on the proceeding steps.

WARNING

Verify that the waveform generator is functioning according to the performance checks. Ensure that all results are within or close to the range of the required specifications; otherwise, refer to the troubleshooting procedures given later in this section.

Perform the following adjustment procedure. If an adjustment cannot be made to obtain a specific result, refer to the troubleshooting procedures.

NOTE If not otherwise specified, configure the instrument to factory defaults before each adjustment by sending the *RST command. Always connect the output BNC connector through a 50Ω feedthrough termination.

Pulse Response Adjustment

Equipment: Oscilloscope (2465B), 20dB Attenuator

1. Configure the Model 3152 as follows:

Function: Square
Frequency: 1 MHz
Amplitude: 10 V
Remote Commands: :RES
:OUTP ON
:FUNC:SHAP SQU
:FREQ 1e6
:VOLT 10

2. Connect the Model 3152 output through 20dB attenuator to the oscilloscope input.
3. Set the oscilloscope input impedance to 50Ω.
4. Set the oscilloscope vertical gain and time base, and adjust R36 and C19 for the best pulse response.
- ~~5. Change the Model 3152 frequency setting to 10.00 KHz.~~
6. Set the oscilloscope vertical gain and time base, and adjust R22 for best pulse flatness.
- ~~7. Change the Model 3152 frequency setting to 1.000 KHz and retouch R22 for best flatness in this range. Repeat Steps 5 and 6 until the best result is obtained in both steps.~~

Amplitude Adjustment

Equipment: DMM, 50Ω feedthrough termination

1. Configure the Model 3152 as follows:

Function: Sine
Frequency: 1 KHz
Amplitude: 16 V
Remote Commands: :RES
:OUTP ON
:FREQ 1E3
:VOLT 16

2. Connect the Model 3152 output to the DMM input through the 50Ω feedthrough termination. Set the DMM to AC Volt measurements and 2 V range.
3. Adjust R44 until the DMM reading is 5.657 V ±20 mV.
4. Change the Model 3152 amplitude setting to 2.0 V.
5. Adjust R44 until the DMM reading is 1.803V ±6 mV.
6. Repeat Steps 4 and 5 until the best result is obtained in both steps.

Revised 5/98

Offset Adjustment

Equipment: DMM, 50Ω feedthrough termination

1. Configure the Model 3152 as follows:

Function: Sine
Frequency: 1 MHz
Amplitude: 1.61 V
Offset: +7.19V
Remote Commands: :RES
:OUTP ON
:FREQ 1e6
:VOLT 1.61
:VOLT:OFFS 7.19

2. Connect the Model 3152 output to the DMM input through the 50Ω feedthrough termination. Set the DMM to DCV measurements and 10 V range. Record this reading.
3. Change the offset setting to -7.19 V and adjust R85 to have the exact reading as was recorded in the previous step (with reversed polarity).
4. Adjust R62 until the DMM reading is -7.190 V ±30 mV.
5. Repeat Steps 3 and 4 until the best result is obtained in both steps.

Maintenance and Performance Checks 5-14

VCO Adjustment

Equipment: DMM

1. Configure the Model 3152 as follows:
Function: Sinewave
Output: On
Remote Commands: :RES
2. Connect the DMM "V" input to U515 pin 1 and the DMM "Common" input to case ground. Set the DMM to DCV measurements.
3. Adjust R536 until the DMM reading is 0 V \pm 500 mV.

Revised 5/99

PLL Adjustment

Equipment: Oscilloscope, Counter, Pulse/Function Generator, Feedthrough Terminator, 3 each BNC Cables, 50 Ω "T" Connector

1. Configure the Model 3152 as follows:

Function: Square wave
Mode: Front Panel PLL
Frequency: 10.00 KHz
Mode: PLL
Phase Offset 45°
Amplitude: 2 V
Trigger Level: 0 V
Remote Commands: :RES
:OUTP ON
:FUNC:SHAP SQU
:FREQ 10.00E3
:PHAS2:LOCK ON
:PHAS2:ADJ 45
:TRIG:LEV 0
:VOLT 2

Maintenance and Performance Checks 5-15

2. Make the following connections:
 - a. Connect function generator output to the input of the 50Ω "T" Connector.
 - b. Connect one end of the 50Ω "T" Connector to the 3152 TRIG IN and the other end to the counter Channel A input.
 - c. Connect the 3152 OUT to the counter Channel B input.
3. Set counter to phase measurement. Terminate counter inputs with 50Ω.
4. Set Pulse/Function generator to output a 2 Vp-p, 10KHz square waveform.
5. Adjust R535 for a counter reading of 45° ±3°. Note and record the exact counter reading for the next adjustment.
6. Set Model 3152 PHAS2:FINE to 36. Adjust R537 until reading falls within the following reading:

Value recorded in step 5 + 36 ±2°.

Troubleshooting

The troubleshooting instructions contained in this section are intended for qualified personnel having basic understanding of analog and digital circuitry. The individual should also be experienced at using typical test equipment as well as ordinary troubleshooting procedures. The information presented here has been written to assist in isolating a defective circuit or circuit section. Isolation to a specific component is left to the technician.

Recommended Test Equipment

Recommended test equipment for troubleshooting and adjustment of the Model 3152 are listed in the section entitled **Recommended Test Equipment** in the beginning of this chapter. Other equipment such as a logic analyzer, an in-circuit emulator, etc., could also be helpful in a difficult situation.

Power-Up Tests

Upon power-up, the Model 3152 performs a set of tests. If the instrument locks up after power on, proceed with the troubleshooting procedure given in the following paragraphs

Self-Test

An advanced feature of the Model 3152 is its self-test capability. This feature helps in reducing troubleshooting time of faulty circuits to the minimum. If the instrument fails its self-test procedure, it will generate an error bit. *TST? initiates the self-test procedure. If the instrument executes its self-test without errors, 0 is placed at the output queue. Non-zero indicates self-test failure.

The self-test procedure is intended to verify general operation of the Model 3152. It does not test for accuracy. Therefore, it should be used as an indication that the Model 3152 operates, in general. The self-test procedure checks about 95% of the Model 3152 hardware. If the self-test procedure fails to respond correctly, troubleshooting the Model 3152 is suggested using the procedure given below.

Maintenance and Performance Checks 5-16

The troubleshooting procedure should also be initiated whenever the synthesizer fails to perform either completely or partially. It is also required to troubleshoot the Model 3152 whenever the instrument fails to fully comply with its published specifications. The information given in the following does not intend to replace full scale troubleshooting, but merely to direct the Service Technician to the area where the source of the trouble is located.

Main Board Circuit Checkout

The Model 3152 is made of two boards. The large board (Part Number 7100-2370) is the main board. There is a smaller board mounted on the main board with three connectors (Part Number 7100-2360). This smaller board is called the "engine board". The following checks are made on the main board. To gain access to components below the engine board, it may be necessary to remove this board entirely. To do so, remove the three screws that tie the engine board to the main board, grasp the engine board from both sides and pull away from the main board.

Power Supply Checkout

It is suggested that the first step in troubleshooting the Model 3152 would be to check the power supply rails. If the various supply voltages within the instrument are not within the required limits, troubleshooting the remaining circuits can be very difficult.

The supply voltages are supplied to the Model 3152 through the backplane. In case of a "dead short" between one of the supplies to the common ground, disconnect the entire supply section from the remaining circuitry, and then determine whether the problem is in the power supply or in the remaining circuits.

A few preliminary checks could help here. First remove the Model 3152 from the VXIbus chassis. Turn on the VXIbus chassis and verify that the supply voltages are available directly on the backplane sockets. Check the following supplies: +24V, -24V, +12V, -12V, +5V, and -5.2V. Check the ripple on these lines using an oscilloscope.

Plug an extension card into one of the slots and plug the Model 3152 into the extension card. Turn the chassis power on and repeat the supply voltage tests as above. If one of the voltages is missing or not within the specified range, it is possible that one of the supply lines is shorted inside the Model 3152. Remove the filter chokes L12 and L13 if there are problems on the +24V or -24V lines; remove L8 or L9 if there are problems on the +5V or -5.2V lines, or remove L10 or L11 if there are problems on the +12V or -12V lines.

CPU and VXI ASIC Checkout

The most important section to be verified after power supply checkout is the CPU and the VXI ASIC section with its various clocks, address, data lines, and chip select serial data communication components. Problems with the digital part could cause erratic operation or erroneous response to word serial commands.

Problems in the CPU and the digital circuit may cause a complete malfunction of the entire instrument. The CPU would not start generating control signals. This makes it impossible to troubleshoot the remaining circuits. Check the various components associated with the CPU circuitry, its clocks, and the components associated with the VXI ASIC using the information given in **Table 5-1**.

Table 5-1 CPU and VXI Interface Checkout Procedure

Step	Test Point	Expected Result
1	CPU Clock - U87 pin 19	16 MHz TTL level clock
2	VXI Clock - U109 pin 159	16 MHz TTL level clock
3	ALE - U85 pin 11	Positive going pulses; period 375 ns, pulse width 120 ns
4	PSEN - U74a and U74b	2.67 MHz TTL level pulses
5	Load a 10000-point wave and perform the following tests during load time	
6	RD - U87 pin 16	Negative going 400 ns width pulses
7	WR - U87 pin 17	Negative going 400 ns width pulses
8	LDACK - U87 pin 5	Negative going 6.5 μ s width pulses
9	ASIC LCS - U104 pin 11	Negative going 6.5 μ s width pulses
10	LR/W - U93 pin 19	Negative going 60 μ s width pulses

Output Amplifier and Amplitude Control Checkout

Problems with the output amplifier and amplitude control circuits can be detected if the Model 3152 accepts word serial commands and responds correctly to word serial queries, but fails to output the correct waveform with correct amplitude and offset levels. If there is a problem with the output amplifier or with the amplitude control circuit, proceed with the checkout procedure given in **Table 5-2**.

Before starting the following procedure, reset the Model 3152 to the factory defaults using the *RST command. Then send the command OUTPUT ON.

Table 5-2 Output Amplifier and Amplitude Control Checkout Procedure

Step	Test Point	Expected Result
1	Junction of R57 and R58	750 mVp-p sinewave, 1 MHz
2	Junction of R18 and R19	10 Vp-p sinewave, 1 MHz
3	Voltage across R37, R41, R46, and R49	Approximately 1.6 V
4	CE voltage on Q9	Approximately 2.8 V
5	U7, pin 1	Approximately -1.1 V
6	U7, pin 7	Approximately 400 mV

Maintenance and Performance Checks 5-18

7	Change amplitude setting to 1.61V and offset setting to 7V	
8	U8, pin 1	Approximately -320 mV
9	U8, pin 7	Approximately -2 V

Maintenance and Performance Checks 5-19

Clock Synthesizer Checkout

Problems with the clock synthesizer circuits can be detected if the Model 3152 accepts word serial commands and responds correctly to word serial queries, but fails to output the correct waveform frequency. If there is a problem with the clock synthesizer circuit, proceed with the checkout procedure given in **Table 5-3**.

Before you start with the following procedure, reset the 3152 to the factory default using the *RST command and change frequency setting to 1 MHz.

Table 5-3 Clock Synthesizer Checkout Procedure

Step	Test Point	Expected Result
1	U510 pin 7	100 MHz ECL level clock
2	U16 pin 15	50 MHz ECL level clock
3	U16 pin 2	25 MHz ECL level clock
4	U505 pin 21	1.5625 MHz TTL level clock
5	U506 pin 6	1.5625 MHz ECL level clock
6	U506 pin 2	1.5625 MHz square waves 2 Vp-p
7	U503 pin 1	1.5625 MHz ECL level clock
8	U503 pin 2	1.5625 MHz ECL level clock
9	Q502, Q503 collector	1.5625 pulses 3 Vp-p on 5 V offset
10	U516 pin 6	Approximately 12 VDC
11	U17 pin 15	100 MHz ECL level clock

Maintenance and Performance Checks 5-20

Sequence Generator Checkout

Problems with the sequence generator circuits can be detected if the Model 3152 accepts word serial commands and responds correctly to word serial queries, but fails to output sequences or bursts. If there is a problem with the sequence generator circuits, proceed with the checkout procedure given in **Table 5-4**.

Before starting the following procedure, reset the Model 3152 to the factory default using the *RST command. Configure the Model 3152 to sequenced output mode and load three different waveforms - 100 points long, to segments 1, 2, and 3, respectively. Program each step to repeat once. Use the following commands after loading the waveforms.

```
Remote Commands:  :FUNC:MODE SEQ
                  :SEQ:DEF 1,1
                  :SEQ:DEF 2,1
                  :SEQ:DEF 3,1
                  :OUTP ON
```

Table 5-4 Sequence Generator Checkout Procedure

Step	Test Point	Expected Result
1	U45 pin 1, U42 pin 11	Negative going pulses; 2 ns width, 100 μ s period
2	U46 pin 1, and 3	Same as above
3	U42 pin 12	Negative going pulses; 100 μ s width, 200 μ s period
4	U42 pin 8, U43 pin 14	Negative going pulses; 2 μ s width, 100 μ s period
5	U44 pin 14, U47 pin 14	Same as above
6	U47 pin 5	Negative going pulses; 2 μ s width, alternating 100 μ s and 200 μ s periods
7	U47 pin 2, and 3	Positive going pulses; 100 μ s width, 200 μ s period

The next checkout is done on the Model 3152 configured to operate in burst mode with 5 bursts. Use the following command to configure the Model 3152:

```
Remote Commands: :FUNC:MODE USER
                  :TRAC:SEL 1
                  :INIT:CONT OFF
                  :TRIG:BURS: ON
                  :TRIG:COUN 5
                  :OUTP ON
```

Connect an external trigger source to the front panel TRIG IN connector. Set external trigger frequency to 1 KHz. Proceed with the checkout procedure given in **Table 5-5**.

Table 5-5 Burst Generator Checks

Step	Test Point	Expected Result
1	U56 through U60 pin 2	Five negative going pulses; 2 ns width, 100 μ s period, repeated every 1 ms
2	U56 through U60 pin 9	Positive going pulses; 200 μ s width, 1 ms period
3	U49 pin 2	Positive going pulses; 400 μ s width, 1 ms period
4	U49 pin 5	Positive going pulses; 300 μ s width, 1 ms period

PLL Checkout

Problems with the phase lock loop circuits can be detected if the Model 3152 accepts word serial commands and responds correctly to word serial queries, but fails to lock to a valid external signal. If there is a problem with the PLL circuits, proceed with the checkout procedure given in **Table 5-6**.

Before starting the following procedure, reset the Model 3152 to the factory default using the *RST command. Configure the Model 3152 to PLL mode, 10 MHz frequency and square waveform. Use the following commands after loading the waveforms.

```
Remote Commands:
                  :RES
                  :OUTP ON
                  :FREQ 10E6
                  :PHAS2:LOCK ON
                  :TRIG:LEV 0
```

Connect an external 10 KHz, 2 Vp-p square waveform to the TRIG IN BNC. Proceed with the checkout procedure given in **Table 5-6**.

Table 5-6 PLL Checkout Procedure

Step	Test Point	Expected Result
1	U513 pin 6	10 KHz square waveform, ECL logic level
2	U513 pin 11	20 μ s width positive going pulses; 100 μ s period, ECL
3	Q502, Q503 collectors	3 Vp-p narrow pulses on 5 V offset

Maintenance and Performance Checks 5-22

Engine Board Circuit Checkout

As described in the paragraph **Main Board Circuit Checkout**, the Model 3152 is made of two boards. If the engine board is removed from the main board, reinstall it before continuing with the following checks. The following circuit checks are performed on the engine board only.

Engine Board Checkout

The “engine board” is the analog heart of the Mode 3152. It contains the waveform memory circuit, high frequency clock drives, and circuitry that drives the D/A converter. The output of the D/A converter is routed directly from the engine board to the output amplifier located on the main board.

Problems with the engine board circuits can be detected if the Model 3152 accepts word serial commands and responds correctly to word serial queries, however, fails to generate waveforms. If there is a problem with the engine board circuits, proceed with the checks given in **Table 5-7a**.

Before starting the following procedure, reset the Model 3152 to the factory default using the *RST command.

Table 5-7a Engine Board Checkout Procedure - #1

Step	Test Point	Expected Result
1	U27 pin 2	±2.5 V squarewave, 1 MHz
2	U41 pins 1 to 11, pin 28	-0.8 V to -1.8 V ECL level squarewave, 1 MHz
3	U41 pin 26	ECL Level Negative going pulses; 2 ns width, 1 MHz
4	U29, U46, U51 pin 1	TTL Level, 50 MHz
5	U17-U20 pins 13-21	TTL Level, 1 MHz
6	U31,U32,U35,U36 pins 17 through 20	TTL Level, 1 MHz
7	U53-U57 pins 13-21	TTL Level, 1 MHz
8	U31-U32 pins 13-15	TTL Level, Positive going pulses; 20 ns width, 1 MHz
9	U35-U36 pins 13-15	TTL Level, Positive going pulses; 20 ns width, 1 MHz
10	U37,U38,U58,U60 pin 9	TTL Level, Negative going pulses; 20 ns width, 1 MHz
11	U39 pin 5	TTL Level, Positive going pulses; 20 ns width
12	U18 pin 4	ECL Level 100 MHz
13	U18 pin 2	ECL Level 100 MHz
14	U15 pin 2, U16 pins 2,3,14,15, U19 pins 2,3,9 14, U20 pin 14, U21 pin 6, 11, U22 pin 6	ECL Level 100 MHz

Change the Model 3152 setting to triggered. Use an external pulse generator to apply a TTL level, 200 KHz signal to the TRIG IN connector. Proceed with the checks given in **Table 5-7b**.

Table 5-7b Engine Board Checkout Procedure - #2

Step	Test Point	Expected Result
1	U13 pin 16	TTL Level, 200 KHz
2	U13 pins 8	TTL Level Positive going pulses; 10 ns width, 200 KHz
3	U39 pin 13	TTL Level Negative going pulses; 10 ns width, 200 KHz
4	U39 pin 8	TTL Level Positive going pulses; 1 μ s width, 200 KHz
5	U26 pin 11	TTL Level Negative going pulses; 1 μ s width, 200 KHz
6	U24 pin 1	ECL Level Negative going pulses; 1 μ s width, 200 KHz

Change the Model 3152 setting to delayed trigger and change delay to 100. Use an external pulse generator to apply a TTL level and 200 KHz signal to the TRIG IN connector. Proceed with the checks given in **Table 5-7c**.

Table 5-7c Engine Board Checkout Procedure - #3

Step	Test Point	Expected Result
1	U14 to U8 pin 9	TTL Level Positive going pulses; 1 μ s width, 200 KHz
2	U10 pin 1, U39 pin 13	TTL Level Negative going pulses; 10 ns width, 200 KHz

Specifications

VXIbus General Information

Module Form	Single slot VXIbus C-size module
Connectors	P1, P2
Protocol	A16/A24/D16 Slave, Message-Based
VXIbus Revision	1.4
SCPI Revision	1993.0
Logical Address Settings	1 - 255, configured via DIP switches
Interrupt Level Settings	1 - 7, configured dynamically (no DIP switch)
Shared Memory	A24, D16, 64K points. Expandable to 512K points Note: 1 point = 2 bytes, shared memory is the same as waveform memory.

Synthesizer Reference Sources/Sample Clock

Reference Sources

External Reference Input from:	VXIbus CLK10
Optional Internal Reference:	PCB layout to provide for either internal (1) 10 MHz TCXO with 1 ppm accuracy or (2) 10 MHz Crystal with 100 ppm accuracy

Sample Clock

External Clock Input from:	(1) Front Panel BNC, Frequency to 100 MHz, ECL compatible (2) ECLTRG0, Synchronous Protocol, ECLTRG trigger acceptor requirements with regard to pulse width and frequency are waived.
External Clock Output to:	ECLTRG0, Synchronous Protocol, VXIbus ECLTRG trigger source requirements with regard to pulse width and frequency are waived.

Triggering Characteristics

Trigger Input Impedance	1 k Ω , \pm 5%
Level	\pm 10 V
Resolution	10 mV
Sensitivity	100 mV rms
Accuracy	\pm (5% of level + 150 mV)
Maximum Input Voltage	30 V rms
Minimum Pulse Width	20 ns
Slope	Positive or negative going edges, programmable

Modes

Normal	Continuous waveform is generated
Triggered	Each input cycle generates a single output cycle
Internal Trigger	An internal timer repeatedly generates a single output cycle
Gated	External signal enables generator. First output cycle synchronous with the active slope of the triggering signal. Last cycle of output waveform is always completed
External Burst	Preset number of up to 1 million cycles are stimulated by an internal, external, or manual trigger
Internal Burst	An internal timer repeatedly generates a burst of up to 1 million counted output cycles
Delayed Trigger	0 to 2 million clock cycles

Trigger Frequency

External	To 5 MHz or VXIbus trigger
Internal Accuracy	From 15 μ s to 1000 s \pm 4%, 15 μ s to 59 μ s; \pm 2%, 60 μ s to 0.99 ms; \pm 0.1%, 1 ms to 99.9 ms; \pm 0.01%, 100 ms to 1000 s

Trigger Sources

Trigger functionality is optionally to:	(1) cause one complete cycle of the selected waveform to be output (2) gate the waveform output while the trigger signal is asserted
Software	IEEE-STD-488.2 *TRG, VXI Word Serial trigger

Specifications A-2

Internal	Internal programmable rate generator
System Delay	From External Trigger input to Waveform Output
Standard Waveforms	120ns + 2 sample clock periods ± 1 sample clock period
Arbitrary Waveforms	150ns + 2 sample clock periods ± 1 sample clock period
External Input from:	1) Front panel BNC, TTL compatible, positive slope 2) TTLTRG0-7, Synchronous Protocol, negative slope, VXIbus TTLTRG trigger acceptor requirements: Minimum pulse width (logic low - asserted) : 20 ns, Minimum pulse width (logic high - unasserted) : 20 ns,
External Output to:	TTLTRG0-7, Synchronous Protocol, negative slope, VXIbus TTLTRG trigger source requirements: Minimum pulse width (logic low - asserted) : 30 ns Minimum pulse width (logic high - unasserted) : 80ns Maximum Clock Frequency : 12.5 MHz Note: For the external trigger output, the trigger source is the programmable Synchronous Signal.

For trigger operation when synchronized, the trigger circuit in the master module has control of the sample clock for all modules. Therefore, the master module must be triggered before any slave can output its waveform.

Backplane Multi-Module Synchronization

Multiple Model 3152 modules may be synchronized. A master Model 3152 module provides the necessary signals to slave Model 3152 modules to achieve synchronization. The signals required are sample clock (distributed on ECLTRG0) and another signal (distributed on ECLTRG1). Phase offset is settable (in degrees) for each slave module with respect to the master module output.

Phase Offset Resolution (P.O.R.)	$360^\circ / \text{Number of Points}$ (min. # points = 10)
Phase Offset Range	0° to $360^\circ - 2880/n$, where n = number of points
Phase Accuracy	$\pm[(20 \text{ nS} \times 360^\circ / \text{PERIOD}) + \text{P.O.R.}]$ P.O.R. = phase offset resolution PERIOD = $1/(\text{output signal frequency})$ Accuracy specified after PHAS:LOCK:NULL command
Jitter	None

Front Panel Indicator LED's

Fail	Red - Power-up self-test failure
Access	Amber - Module addressed on VXIbus
PLL On	Amber - 3152 is locked to external signal

Output On Green - Output On/Off

Front Panel Input/Output Connectors

Main Output	Signal Output (BNC)
Marker/Sync Output	Marker/Sync Output (BNC)
Trigger Input	External Trigger Source Input (BNC)
Sample Frequency Input	Sample Frequency Input (BNC)
PM Input	Phase control Input (BNC)

Power

VXIbus Rail	Peak Current	Dynamic Current
+24 V	< 250 mA	< 250 mA
+12 V	< 100 mA	< 100 mA
+5 V	< 3 A	< 150 mA
-5.2 V	< 2 A	< 150 mA
-12V	< 100 mA	< 100 mA
-24V	< 250 mA	< 150 mA
-2V	n/a	n/a

Maximum Total Module Power	< 40 W	64K
	< 45 W	512K

Self-Test Fault Coverage

Fault Coverage (%) 90%

EMC

Radiated Emissions (Close Field)	VXIbus B.8.6.3, Rev 1.4
Radiated Susceptibility	VXIbus B.8.6.4, Rev 1.4
Conducted Emissions	VXIbus B.8.7.3, Rev 1.4
Conducted Susceptibility	VXIbus B.8.7.4, Rev 1.4

Mechanical

Dimensions	Per Racal Instruments VXIbus corporate package drawings
Weight	3 lbs. 8 oz. (1.6 kg)
Airflow (for 10°C rise)	3.7 l/S

Specifications A-4

Pressure (for 10°C rise) 0.5 mm H₂O

Environmental

Operating Temperature 0° C - 55° C
Storage Temperature -40°C - +70°C
Humidity (non-condensing)
11° C - 30° C 95% ±5%
31° C - 40° C 75% ±5%
41° C - 50° C 45% ±5%
Altitude
Operating 10000 ft
Storage 15000ft
Vibration 5 - 55 Hz sine (2g at 55 Hz), non-operating
Shock 30g 11 ms half sine pulse, non-operating
Bench Handling 4", any face, wooden surface, non-operating

Safety Designed to meet IEC 1010-1, UL 3111-1, CSA 22.2 #1010

Workmanship Standards

PCB Assembly Conform to IPC-A-610D

Output Characteristics

Output Via front panel OUTPUT BNC terminal
Stand-By Output Normal or Off
Impedance 50Ω ±1%
Protection Protected against temporary short to case ground
Glitch Energy <1 nV-s at 16 Vp-p
Amplitude 20 mV to 32 Vp-p, into open circuit
10 mV to 16 Vp-p, into 50Ω
Resolution 4 digits
Accuracy (1 kHz) ±(1%+20 mV) from 1.610 V to 16.00 V
±(1%+2 mV) from 161.0 mV to 1.600 V
±(1%+200 μV) from 10.00 mV to 160.0 mV

Offset

Dependency Offset and Amplitude are independently adjustable within level windows: ±8 V, ±800 mV, and ±80 mV

Specifications A-5

Range	0 to ± 7.190 V within ± 8 V window 0 to ± 719.0 mV within ± 800 mV window 0 to ± 71.90 mV within ± 80 mV window
Resolution	4 digits
Accuracy	$\pm(1\% + 1\%$ of amplitude +20 mV) ± 8 V window $\pm(1\% + 1\%$ of amplitude +2 mV) ± 800 mV window $\pm(1\% + 1\%$ of amplitude +200 μ V) ± 80 mV window
Filters	50 MHz 7-pole elliptic 25 MHz 7-pole elliptic 20 MHz 7-pole Gaussian

Square Wave, Pulse

Rise/Fall time	5 ns Typical, 10% to 90% of amplitude
Aberration	<5%
SYNC Output	Via front panel SYNC OUT BNC terminal
Level	TTL
Protection	Protected against temporary short-to-case-ground

Standard Waveforms

Frequency Range	Waveform dependent
Source	Internal Synthesizer
Resolution	7 digits
Accuracy	Same as frequency standard
Stability	Same as frequency standard

Sine

Frequency Range	100 μ Hz to 50 MHz
Distortion	<0.1%, below 100 kHz (2000 points minimum)
Harmonics	<5 MHz, ≤ 10 Vp-p, -50 dBc <5 MHz, ≤ 16 Vp-p, -45 dBc <10 MHz, ≤ 10 Vp-p, -40 dBc <10 MHz, ≤ 16 Vp-p, -35 dBc <50 MHz, ≤ 10 Vp-p, -28 dBc <50 MHz, ≤ 16 Vp-p, -23 dBc
Band Flatness	1%, to 1 MHz; 5% to 10 MHz; 15%, to 50 MHz
Programmable Parameters	
Start Phase	0 to 360°
Power (sine ^X)	1 to 9

Specifications A-6

Triangle

Frequency Range	100 μ Hz to 1 MHz, usable to 10 MHz
Adjustable Parameters	
Start Phase	0 to 360°
Power	1 to 9

Square

Frequency Range	100 μ Hz to 50 MHz
Adjustable Parameters	
Duty Cycle	1% to 50%

Pulse/Ramp

Frequency Range	100 μ Hz to 1 MHz
Adjustable Parameters	
Delay	0% to 99.9% of period
Rise Time	0% to 99.9% of period
High Time	0% to 99.9% of period
Fall Time	0% to 99.9% of period

Sinc (Sine(x)/x)

Frequency Range	100 μ Hz to 1 MHz
Adjustable Parameters	
Cycles	4 to 100 cycles

Gaussian Pulse

Frequency Range	100 μ Hz to 1 MHz
Adjustable Parameters	
Time Constant	1 to 200

Exponential Decaying/Rising Pulse

Frequency Range	100 μ Hz to 1 MHz
Adjustable Parameters	
Time Constant	-100 to 100

DC

Range 1% to 100% of amplitude

Arbitrary Waveforms

Waveform Memory 64k (256K or 512K optional) points
Memory Segmentation
 Number of Segments 1 to 4096
 Min Segment Size 10 point
Vertical Resolution 12 bits (4096 points)

Sampling Clock

Source Internal synthesizer, external clock, ECLTRG0
Range
 Internal 100 mHz to 100 MHz
 External To 100 MHz
 Internal Reference 10 MHz, fixed internal crystal clock frequency
Resolution 7 digits
Accuracy Same as frequency standard
Stability Same as frequency standard

Sequenced Waveforms

Operation Permits division of the memory bank into smaller segments. Segments may be linked and repeated in user-selectable fashion to generate extremely long waveforms
Sequencer steps From 0 to 4096
Segment loops From 0 to 1 million. Number of repeated sequencer steps are limited by $N = 4096 - \text{Number of repeated steps}$. There are no limitations below 2048 repeated sequencer steps.
Segment Duration Minimum 100 ns for more than one loop

Sampling Clock

Source Internal synthesizer, external clock, ECLTRG0
Range
 Internal 100 mHz to 100 MHz
 External To 100 MHz
 Internal Reference 10 MHz, fixed internal crystal clock frequency
Resolution 7 digits

Specifications A-8

Accuracy
Stability

Same as frequency standard
Same as frequency standard

PLL Characteristics

Operation
PLL Input Characteristics
External Lock Frequency Range
Standard Waveforms

Automatically locks to external signal
Same as TRIG IN

500 Hz to 200 kHz; frequency setting 500 Hz to 200 KHz; 500 Hz to same value as internal frequency setting, 200 kHz to 10 MHz. See graph below.

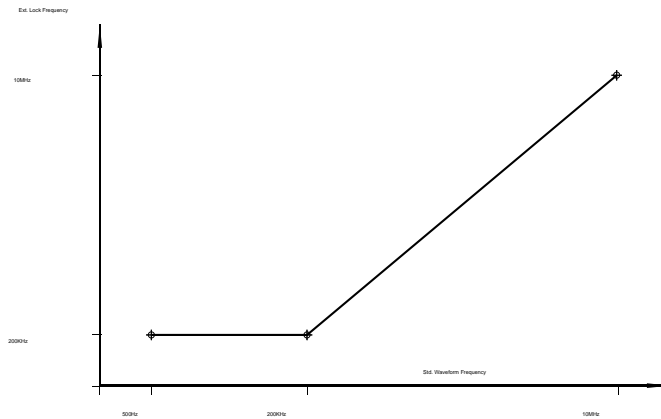

Arbitrary Waveforms

500 Hz to 100 MHz divided by number of waveform samples. See graph below.



Coarse Phase Offset Control

Range

$\pm 180^\circ$

Resolution

Std. Waveforms

0.72° , frequency setting from 500 Hz to 200 kHz;
 $360^\circ \times \text{frequency (in MHz)} / 100$, frequency setting from
 200 KHz to 10 MHz

Arbitrary Waveforms

$360^\circ / \text{waveform samples}$

Accuracy

$5.4 \times \text{frequency (in MHz)} + \text{resolution} / 2 \pm 5^\circ$

Fine Phase Offset Control

Range

$\pm 36^\circ$ around coarse phase offset setting

Resolution

0.01°

Accuracy

10%, typical

Frequency Counter

Operation

Made available to the user in PLL mode only.

Frequency reading is valid only when PLL ON LED is lit

Range

Same as External Lock Frequency Range above

Resolution

4 digits

PM Characteristics

Operation

External signal offsets phase. This input is operational in PLL mode.

Bandwidth

See graph below

Specifications A-10

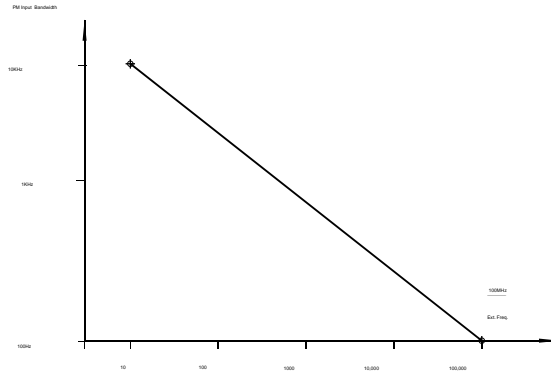

PM Input

Impedance

100 K Ω , $\pm 5\%$

Sensitivity

20 \circ /V, typical

Accuracy

$\pm 30\%$

This page was intentionally left blank

Specifications A-12

REPAIR AND CALIBRATION REQUEST FORM

To allow us to better understand your repair requests, we suggest you use the following outline when calling and include a copy with your instrument to be sent to the Racal Repair Facility.

Model _____ Serial No. _____ Date _____

Company Name _____ Purchase Order # _____

Billing Address _____

City

State/Province

Zip/Postal Code

Country

Shipping Address _____

City

State/Province

Zip/Postal Code

Country

Technical Contact _____ Phone Number () _____

Purchasing Contact _____ Phone Number () _____

1. Describe, in detail, the problem and symptoms you are having. Please include all set up details, such as input/output levels, frequencies, waveform details, etc.

2. If problem is occurring when unit is in remote, please list the program strings used and the controller type.

3. Please give any additional information you feel would be beneficial in facilitating a faster repair time (i.e., modifications, etc.)

4. Is calibration data required? Yes No (please circle one)

Call before shipping

Ship instruments to nearest support office

Note: We do not accept
"collect" shipments.

listed on back.

Support Offices

Racal Instruments, Inc.
4 Goodyear Street
Irvine, CA 92718-2002
Phone: 1-714-859-8999
1-800-RACAL-ATE
1-800-722-2528
FAX: 1-714-849-2505

Racal Instruments Ltd
480 Bath Road
Slough, Berkshire
SL1 6BE, England
Phone: +44 (0) 1628 604455
FAX: +44 (0) 1628 662017

Racal Systems Electronique s.a.
18 Avenue Dutartre
78150 LeChesnay, France
Phone: +33 (1) 3955 8888
FAX: +33 (1) 3955 6735

Racal Systems Elettronica Srl
Strada 2-Palazzo C4
20090 Milanofiori Assago
Milan, Italy
Phone: +39 (2) 5750 1796
FAX: +39 (2) 5750 1828

Racal Elektronik System GmbH
Frankenforster Strasse 21
51427 Bergisch-Gladbach ,1Germany
Phone: +49 2204 92220
FAX: +49 2204 21491

Racal Australia Pty Ltd
3 Powells Road
Brookvale, NSW 2100, Australia
Phone: +61 (2) 936 7000
FAX: +61 (2) 936 7036

Racal Electronics Pte Ltd
26 Ayer Rajah Crescent, 04-06/07
Ayer Rajah Industrial Estate, Singapore 0513
Phone: +65 7792200
FAX: +65 7785400



Artisan Technology Group is your source for quality new and certified-used/pre-owned equipment

- FAST SHIPPING AND DELIVERY
- TENS OF THOUSANDS OF IN-STOCK ITEMS
- EQUIPMENT DEMOS
- HUNDREDS OF MANUFACTURERS SUPPORTED
- LEASING/MONTHLY RENTALS
- ITAR CERTIFIED SECURE ASSET SOLUTIONS

SERVICE CENTER REPAIRS

Experienced engineers and technicians on staff at our full-service, in-house repair center

*InstraView*SM REMOTE INSPECTION

Remotely inspect equipment before purchasing with our interactive website at www.instraview.com ↗

WE BUY USED EQUIPMENT

Sell your excess, underutilized, and idle used equipment. We also offer credit for buy-backs and trade-ins. www.artisanng.com/WeBuyEquipment ↗

LOOKING FOR MORE INFORMATION?

Visit us on the web at www.artisanng.com ↗ for more information on price quotations, drivers, technical specifications, manuals, and documentation

Contact us: (888) 88-SOURCE | sales@artisanng.com | www.artisanng.com