

MILLENNIUM (MJ30-4)  
(MJ32-4)  
(MJ31-4

INSTALLATION & SERVICE  
MANUAL



*IMI CORNELIUS INC.*

One Cornelius Place, Anoka, Minnesota 55303  
Phone (800) 238-3600 or (612) 421-6120 Fax (612) 422-3255



Part No. 85318  
Rev. A 8/98



# *Table of Contents*

Description.....	Page 2
Specifications .....	Page 3
Receiving & Unpacking.....	Page 4
Installation .....	Page 4-6
?? Connect Drain	
?? Connect Water Supply	
?? Fill Ice Water Bath	
?? Connect Power Supply/Start Refrigeration	
?? Purge Air from System	
?? Connect B-I-B Concentrate	
?? Priming the Concentrate Pumps	
?? Sanitizing prior to Initial Use	
?? Apply Sealant to Base & Counter Top	
Bringing Concentrate.....	Page 6
Cleaning & Sanitizing the System.....	Page 6-7
?? Flushing the Concentrate Lines & Valves	
?? Cleaning & Sanitizing the Concentrate Lines & Valves	
Daily Cleaning & Maintenance.....	Page 8
Maintenance of the Refrigeration System .....	Page 8-9
?? Cleaning of the Refrigeration Components	
?? Ice Water Bath Cleaning	
Troubleshooting Guide .....	Page 10-17
Wiring Diagram .....	Page 18
Exploded View/Parts Identification.....	Page 19-29
Recommended Spare Parts (Service Agents Only) .....	Page 30
Optional Accessories .....	Page 31
Warranty.....	Page 32

## *General Description*

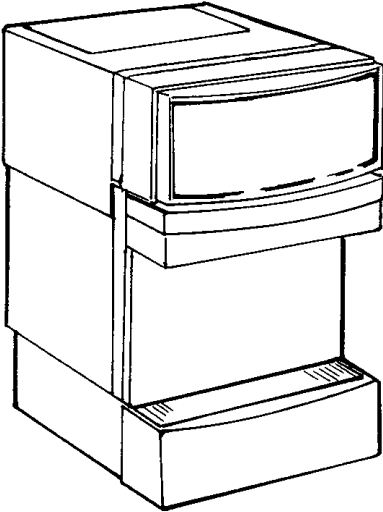

The Millennium™ is a state of the art four product B-I-B juice dispenser. It's integral high performance, dual speed peristaltic mini pumps eliminate the need to purchase separate B-I-B pumps. The Millennium™ can draw product directly from the B-I-B's up to 50 feet away (15 feet vertically) allowing for greater installation flexibility! Additionally, the Millennium™ incorporates a unique valve assembly which mixes the concentrates more thoroughly than similar models.

Wilshire realizes that counter space is at a premium in any operation. The Millennium™ maximizes the use of counter space by providing four product capability in a 15 inch wide chassis. Because the air circulation is through the top, the Millennium™ can be installed with zero clearance in the back. For improved serviceability, all components can be accessed through the top or front without disturbing equipment placed on either side.

With it's innovative compact design, reduced operating expense, ease of use and service we're certain the Millennium will meet the most demanding conditions for many years to come.

# Specifications

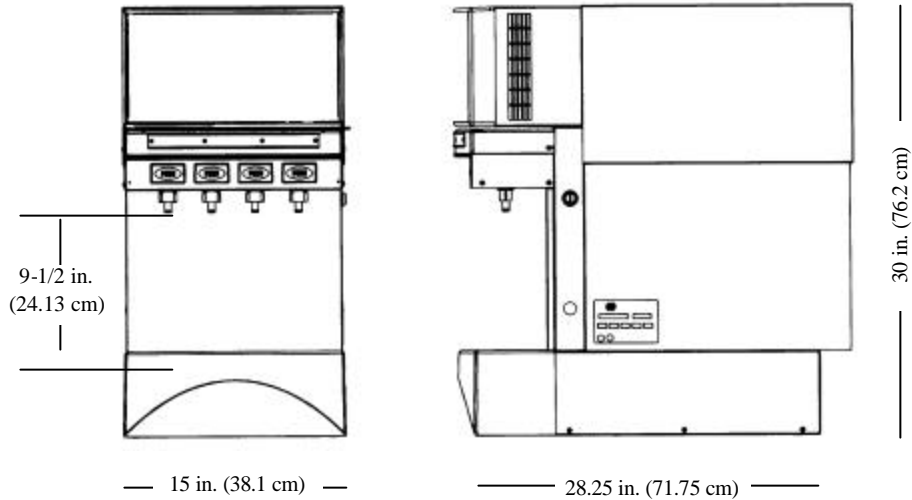

Model Number .....	MJ30-4
Electrical Ratings .....	115VAC / 1 Phase / 60 Hz, 10 Amps
Electrical Connection.....	3 Prong Plug w/ Ground (supplied)
.....	15 Amp Receptacle w/ Ground
.....	15 Amp Circuit Breaker
Water Requirements .....	3/8 in. (9.5 mm.) SAE male flare inlet
.....	20-100psi (1.4-7bar) max. static
pressure	
.....	3.0 oz. (88.7 ml.) water flow per second
Refrigeration .....	8.5 oz. R-134a Refrigerant
.....	1/3 hp. Compressor
.....	Test Pressures:
.....	High 460 psi (31.2 bar)
.....	Low 200 psi (13.5 bar)
.....	Air Cooled Condenser
Recommended Clearance .....	18 in. (45.72 cm.) on top, 4 in. on sides
Weight .....	Shipping, 150 lbs (68.1 kg.)
.....	Operation, 241 lbs (109.4 kg.)
Approvals .....	U.L., C.U.L., N.S.F.

\* Low speed rating is 2/3 of the high speed

## Receiving & Unpacking

1. Inspect the carton and note any damage, regardless if it appears minor. If the carton is damaged, note on the consignee copy of the freight invoice “exterior carton damage - concealed damage possible.”
2. Cut the plastic banding strap and remove the exterior carton sleeve, internal fillers and plastic bag around the dispenser. Carefully inspect for damage.

***Note: IMI Cornelius is not responsible for damaged freight. If damage is found, you must save all packaging material and contact the freight carrier. Failure to contact the carrier within 48 hours of receipt may void your claim.***

3. Confirm receipt of the installation kit #720202300 packaged with the dispenser. If any item is missing, contact our customer service department at 1-800-238-3600 Monday - Friday between the hours of 8:00 AM and 4:30 PM CST.

### Kit Contents:

Qty	Description
4	3/8" barb
4	3/8" swivel nut
5	3/8"x3/8" elbow barb
6	3/8" nylon washer
10	#170 clamps
10 ft.	3/8" braided tubing
4 ft.	1/2" I.D. clear tubing
1	1/2"x1/2" 90o elbow
4	Generic B-I-B connectors
2	Flavor strip kits
1	Installation template

4. Remove the four 9/16" (15 mm) retaining bolts from the underside of the shipping pallet by carefully tilting the dispenser from side to side.
5. With the assistance of another person, lift the dispenser from under the base and place it on the counter.



The dispenser is extremely heavy when operational. Make certain the counter can support a minimum of 300 lbs directly below the dispenser.

## Installation

Typically the dispenser is placed directly on the counter and a food grade silicone sealant applied around the base. However, an optional leg kit is available. The following instructions assume the optional leg kit will not be used.



Depending on the type of counter, it may be necessary to provide access through the counter at the rear of the dispenser for the drain, power, water and concentrate connections. Refer to the template enclosed in the installation kit.

### Connect Water Supply:

*Water pipe connections and fixtures directly connected to a potable water supply shall be sized, installed, and maintained according to federal, state, and local laws.*

Wilshire recommends that a 1/2" O.D. copper supply line with a shut-off valve and water filter be located within 3-6 feet (0.91-1.83 m) of the dispenser.

- a. Assemble the 3/8" braided water supply line furnished in the Installation Kit by attaching the straight barb on one end and the elbow barb on the other. Secure with clamps provided.

- b. Insert a 3/8" nylon washer into the elbow barb of the supply line. Connect the assembled supply line to the water inlet fitting located on the rear of the dispenser.

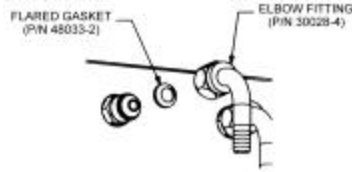

- c. Connect the water supply line to the shut off. Turn on the water and check for leaks.

**NOTE:** The dynamic water pressure must be 20 PSIG (3.1 bar) minimum to ensure correct valve flow control and **must not** exceed 100 PSIG to avoid valve damage.

### **Fill Ice Water Bath:**

- a. Remove the top cover
- b. Remove the large red plastic plug from the filler hole in the top of the refrigeration deck.
- c. Fill the water bath with cool water until it begins to trickle out of the overflow tube.
- d. Reinstall the red plastic plug and top cover.

### **Connect Power Supply / Start Refrigeration:**

- a. Start the refrigeration system by plugging the power cord into a 115 VAC (+ 10%), 15 amp grounded receptacle.

The Millennium forms an ice bank of approximately 30 lbs (13.61 kg) in 4-5 hours at a room temperature of 75°F (24°C). Once the ice bank has grown to the proper size, the ice bank control will shut down the refrigeration circuit.

**NOTE:** It is normal to see water trickle from the over flow as the ice bank forms.

### **Connect B-I-B Concentrate**

- a. Attach the supplied 3/8" (9.5mm) elbow barbs to the end of each 3/8" I.D. B-I-B concentrate supply line (not supplied). Secure with clamps provided. Insert a 3/8" nylon washer into the elbow barb and connect the supply lines to the rear of the dispenser noting the valve numbering (numbered 1-4 from left to right as viewed from the front of the dispenser).
- b. Route the concentrate supply lines to the B-I-B location and attach the gray plastic B-I-B connector (supplied) to the end of each line. Secure with clamps provided.

### **Connect Drain:**

- a. Attach the clear drain hose to the barb fitting on the drip tray. Route the drain hose out from the rear of the dispenser and connect it to a suitable drain source, ensuring compliance with all federal, state, and local plumbing codes. Slide the drip tray into place.

### **Purge Air from the Water Coil**

Prior to initial use, purge all air from the valves by pushing the dispensing switch repeatedly. Continue until a steady flow of water is observed. Repeat the above on the remaining valves.

### **Priming the Concentrate Pumps**

- a. Turn off the water supply.
- b. Connect the concentrate lines to their respective B-I-B.
- c. Depress and hold each start button until concentrate is observed flowing from the dispense nozzle.
- d. Turn on the water supply.

## ***Sanitizing Prior to Initial Use***

The beverage system must be cleaned and sanitized after installation is completed to safe guard against any possible contaminants which may have entered the system during transport or installation. Refer to the “Cleaning & Sanitizing the System” section of this manual for procedures.

## ***Apply Sealant to Base & Countertop***

If the optional legs are not used to raise the dispenser off the counter, the entire perimeter of the base must be sealed at the counter top with silicone (or other food grade approved sealant) in order to comply with N.S.F. standards. Refer to the template supplied in the Installation Kit.

## ***Brixing Concentrate***

The following procedures describe how to adjust the water to concentrate ratio (brix) according to taste. Contact your concentrate supplier for recommended brix ratios.

- a. Remove the flavor strip cover above the dispense valves.
- b. Sample the finished drink. Increase or decrease the water ratio by turning the water flow control screw clockwise (more water) or counterclockwise (less water) until the desired water to concentrate ratio is achieved. Repeat procedure on remaining valves.
- c. Replace the flavor strip cover.

***NOTE:*** *If the flow control does not respond there may be debris caught between the internal ceramic spool and sleeve. Try dislodging the debris by pressing the dispense switch several times or turning the flow control adjustment screw all the way in and out several times.*

## ***Cleaning & Sanitizing the System***

The dispenser must be cleaned and sanitized after installation and as required by state and local health departments, or every 3 months minimum. Your state or local health codes may require more frequent and extensive sanitizing procedures.

## ***Cleaning and Sanitizing Equipment and Supplies:***

- ?? Recommended sanitizer/cleaner:  
*Stera-Sheen® Green Label* prepared to ensure 200 ppm of available chlorine (one-2 oz. packet/1 gallon (3.8 L) of water = 200 ppm). Solution temperature should be between 80°F - 100°F (26.7°C - 37.8°C).
- ?? One clean 5 gallon (19 L) bucket
- ?? One clean 1 gallon (3.9 L) container or bucket
- ?? Clean non-abrasive clothes
- ?? A small brush
- ?? Three empty bag in the box bags (to cut valve fittings off)

## ***Flushing the Concentrate Lines & Valves***

Cleaning and sanitizing is not required for potable water circuits. Potable water lines should remain connected and operational during the cleaning and sanitizing procedures for juice circuits.

- a. Fill the 5 gallon (19 L) bucket with clean extremely hot tap water, approximately 140°F (60°C).
- b. Take the three empty bag in the boxes and remove the bags from the carton. With scissors, cut the bag valve off of the bag and clean the valve by rinsing it under hot tap water.



- c. Connect the bag valve to the gray bag connector and submerge the parts in the bucket of hot water.
- d. Depress and hold the dispense button until the concentrate has been fully purged from the product lines and valves.

**IMPORTANT**  
Do Not flush more than three valve circuits simultaneously.

- e. Once the concentrate is purged, pulse each valve for 15 seconds on and then release the button. Repeat this pulsing for 15 cycles for each circuit being cleaned. Once the 15 cycles have been completed, allow each valve to dispense for 3 continuous minutes.
- f. Remove the nozzles and static mixers from the dispenser and rinse them under hot tap water to remove any remnant of excess concentrate. Repeat for each circuit to be cleaned.
- g. Replace the nozzles and static mixers into their proper location.
- h. Discard any remaining hot water left in the bucket.

### ***Cleaning & Sanitizing the Concentrate Lines and Valves***

- a. Prepare 5 gallons (19 L) of *Stera-Sheen® Green Label* cleaning and sanitizing solution by mixing one 2 oz. packet/1 gallon (3.8 L) of potable water. This will provide enough sanitizing solution to clean and sanitize all 4 concentrate circuits for most installations. Installations that have 50 or more feet of concentrate line may require more sanitizing solution.

**IMPORTANT**  
*Use potable water at 80°F-100°F (26.7°C-26.7°C) to create solution. Water temperatures above this range will breakdown the chlorine count and minimize sanitation.*

- b. Submerge the bag connector and bag valve assembly into the bucket of sanitizing solution.
- c. Depress and hold the dispense button until sanitizing solution is dispensed through the mixing valves nozzle.
- d. Pulse each valve for 15 seconds on and then release the button. Repeat this pulsing for 15 cycles for each circuit being sanitized. Once the 15 cycles have been completed, allow the sanitizing solution to stand in the product lines and valves for 30 minutes.
- e. While waiting, remove the nozzles and static mixers and place them into a separate container with 2 qts. (1.9 L) of sanitizing solution. Agitate vigorously using the small brush to remove any excess concentrate. Allow the parts to soak for 30 minutes.
- f. Clean the dispensing valves mixing chamber with the brush and sanitizing solution (this is the cavity from which the nozzle is removed).
- g. Replace the nozzles and static mixers into their proper locations and discard the sanitizing solution used to soak them in.

***Note: Do not reuse the sanitizing solution used to clean the nozzles, static mixers, etc.***

- h. Activate the dispensing valves for two more cycles (15 seconds on then off) with sanitizing solution then run solution continuously through the dispensing valves for 2 minutes.
- i. Disconnect the bag valves from the gray bag connectors and re-connect the bag connectors to their appropriate product bags.
- j. Depress and hold each dispense button until juice appears at the outlet of the dispensing nozzle. Dispense and discard two 8 oz. (237 ml) cups of juice and verify that there is no chlorine off taste.

## ***Daily Cleaning and Maintenance***

- a. On a daily basis, clean the external cabinet splash areas using a clean damp cloth. Remove and wash the cup rest, dispensing nozzles, and static mixers with clean water. Wipe dry with a clean soft cloth.
- b. Wipe the drip tray in place on the unit, wash the tray out with a mild soap solution, then rinse the tray by pouring water down the drip tray's drain.
- c. Clean all external surfaces of the dispenser with a sponge and a mild soap solution. Rinse the sponge out with clean water, then wring the excess water from the sponge and wipe all external surfaces of the dispenser.
- d. Wipe the dispenser dry with a clean soft cloth. **DO NOT USE ABRASIVE TYPE CLEANERS.** Install the cup rest, dispensing nozzles, and static mixers on the dispenser.

## ***Maintenance of the Refrigeration System***

***Cleaning of the refrigeration components should be performed by a qualified service technician.***

- a. Continuous maintenance of this dispenser is a basic requirement for proper operation and sanitation, including all support equipment utilized in the daily operation of this equipment.
- b. Cleaning of the Refrigeration Components:
- c. Disconnect the power before removing the top bonnet of the dispenser.
- d. The dispenser's ventilation grilles and the condenser fins should be cleaned periodically to maintain efficient refrigeration and to avoid compressor failure. The condenser fins can be cleaned

with a vacuum cleaner or a soft bristle brush.

- e. Clean the exterior surfaces of the compressor, agitator motor, fan motor, and fan blade with a damp cloth to wipe off the accumulated dust.

## ***Ice Water Bath Cleaning***

The water bath should be cleaned to obtain maximum cooling efficiency. It is recommended that the water bath be cleaned two to four times annually, depending upon local conditions and/or as required by state and local health departments.

A convenient time to do this is at the time the dispenser is being sanitized. To save time, the water bath can be drained while the dispenser is being sanitized.

- a. Remove the cup rest and splash panel to access the water bath's drain hose. Extend the drain hose to a suitable waste receptacle and allow the water bath to drain.
- b. Remove the dispenser's top bonnet by removing the two screws located on the top of the bonnet. While lifting the bonnet up and away from the dispenser, unplug the merchandiser electrical cord from the power strip located on the refrigeration deck.
- c. In order to remove the refrigeration deck for the water bath and evaporator cleaning, remove the two screws that secure the deck to the cabinet structure. Unplug the refrigeration deck's main power strip cord from the dispenser's power cord. Disconnect the red, white and blue 12 pin plugs from the electrical box. Disconnect the key switch a by unplugging the white 2 pin plug at the transformer.

***Note: It will be necessary to melt the ice bank to be able to pull the refrigeration deck up and away from the dispenser. Warm water may be used to accelerate the melting. In order to prevent ice bank control damage, do not direct the warm water stream on to the sensing bulb***

***of the ice bank control. Never use an ice pick or other instrument to remove ice from the evaporator. Such practice can result in a punctured refrigerant circuit or damage to the water bath tank.***

- d.** Once the ice bank is sufficiently melted, lift the entire refrigeration deck up and away from the water bath by lifting the deck using it's service handle strap.
- e.** Prepare 1 gallon (3.9 L) of cleaning and sanitizing solution (see "Sanitizing the Concentrate Lines & Valves"). Pour the cleaning and sanitizing solution into the water bath and clean the sides and bottom of the tank, the product coils, and associated brackets with a fiber brush.
- f.** Utilizing the cleaning and sanitizing solution in the water bath, the fiber brush, and a clean cloth soaked with sanitizing solution, clean the refrigeration deck's evaporator coils, agitator motor shaft and blade, and the ice bank sensing bulb.
- g.** Drain the cleaning and sanitizing solution from the water bath and rinse/flush all the components with clean water.
- h.** Re-install the refrigeration deck into the water bath and secure with two screws.
- i.** Connect the refrigeration deck's power strip to the dispenser's power cord. Connect the red, white and blue 12 pin plugs to the electrical box. Connect the key switch to the transformer.
- j.** Fill the water bath with cool potable water until water begins to flow from the overflow tube.
- k.** Plug the merchandisers power cord into power strip located on the refrigeration deck and re-install the top bonnet. Secure the bonnet assembly with two screws.
- l.** Install the splash panel and cup rest and plug the dispenser's power cord into the electrical outlet.

## *Troubleshooting Guide*

<b>Problem</b>	<b>Probable Cause</b>	<b>Remedy</b>
<p><u>DISPENSER IS TOTALLY INOPERATIVE</u></p>	<p>No power present at the source.</p> <p>Power is present at the source...dispenser is still inoperative.</p>	<p>Check the power circuit for a blown fuse or tripped circuit breaker. Check the supply line for the proper amperage and voltage ratings.....dedicated 15 amps /115 volts.</p> <p>Check the power cord connection located behind the front splash panel.</p>
<p><u>DISPENSER WILL NOT COOL</u></p> <p>Drink temperature should be 35-45°F (2-7°C)</p>	<p>Refrigeration shut off switch is in the off position.</p> <p>Low water bath level.</p> <p>Depleted ice bank ( not applicable after period of heavy usage.)</p> <p>Defective Ice bank control.</p>	<p>Refrigeration shut off switch is located on the top of the dispenser . This switch will disable the compressor and the condenser fan motor. Be sure the switch is in the on position.</p> <p>Check water bath level. If 2 gallons or more are added, cause of problem has been confirmed.</p> <p>Check compressor. If running, allow the system time to recover (approximately 1 hour). If compressor is not running or the system is not recovering see the Refrigeration System Troubleshooting section.</p> <p>See Refrigeration System Troubleshooting section.</p>
<p><u>WITH POWER PRESENT, UNIT WILL NOT DISPENSE ALL VALVES.</u></p>	<p>Key lock switch in the OFF position.</p> <p>Transformer not connected or defective.</p> <p>Fuse blown between the transformer and voltage regulator boards.</p>	<p>Check position of the key lock switch. Check for loose wire connections. Run continuity check, replace as needed.</p> <p>Check the connection between the power strip and the transformer. Check transformer output at terminal junction on control box for 26 VAC.</p> <p>Check the fuse located in the electrical box, left side. This box is located on the refrigeration deck and will require the removal of the upper bonnet. Replace fuse as needed.</p>

## *Troubleshooting Guide*

<b>Problem</b>	<b>Probable Cause</b>	<b>Remedy</b>
<p><u>UNIT DISPENSING CONCENTRATE ONLY NO WATER TO ALL VALVES</u></p>	<p>No water reaching dispenser from the water supply line.</p> <p>Water pressure over 100 psi or 7 bar. High pressure will not allow the water solenoids to open.</p> <p>Freeze up of water coil.</p>	<p>Check line to see if the water is shut off at the source.</p> <p>Install regulator onto incoming water line to reduce the pressure to between 30 and 80 psi. (2-5- bar).</p> <p>Refer to the Refrigeration System Troubleshooting section.</p>
<p><u>FROM SINGLE VALVE UNIT WILL NOT DISPENSE WATER OR CONCENTRATE.</u></p>	<p>Inoperative or defective push button switch.</p> <p>Defective Voltage Regulator (VRB) board.</p>	<p>Check for loose or broken wire connections at the switch. Check the continuity of switch. Replace as needed.</p> <p>The VRB boards are contained in the electrical box mounted on the refrigeration deck.. There is one for each valve.</p> <p><b>CAUTION:</b> Access to this panel requires the removal of the upper bonnet while the dispenser is energized and operational. Check the power input for 26 VAC and the output for 28 VDC.</p>
<p><u>FROM SINGLE VALVE, UNIT IS DISPENSING CONCENTRATE ONLY.</u></p>	<p>Inoperative water valve solenoid coil.</p> <p>Solenoid makes clicking sound when energized, but still does, not function.</p> <p>Flow control binding or defective.</p>	<p>Check to see all wire connections are secured at the coil. Check power for 26 VDC. If power is present, coil maybe defective , replace as needed. Armature maybe stuck, disassemble and check function. Return spring could also be defective replace as needed.</p> <p>Disassemble the coil assembly and check plunger seal for defects. Replace as required. Inspect valve seat for restrictions.</p> <p>Disassemble flow control assembly and check the spool and sleeve assembly . Be sure the spool moves freely within the sleeve and there are no restrictions.</p>

## *Troubleshooting Guide*

<b>Problem</b>	<b>Probable Cause</b>	<b>Remedy</b>
<p><u>FROM SINGLE VALVE, UNIT IS DISPENSING WATER ONLY.</u></p>	<p>Concentrate container empty.</p> <p>BIB connector is not engaged or improperly installed.</p> <p>Air leak in product suction line.</p> <p>No power at the pump motor.</p> <p>Defective gear motor assembly.</p> <p>Pump running backwards.</p> <p>Defective concentrate pump tubing.</p>	<p>Replace.</p> <p>Check BIB connector for proper installation. Plunger should be completely inserted with concentrate filling the line to the dispenser.</p> <p>Check the 3/8 flare connection where the product line attaches to the unit. Tighten fitting using a flare gasket. If line is drawing air, pump will not prime.</p> <p>Check for broken or loose wire connection going to pump motor. Check for 26 VDC at pump motor when the dispense button is energized.</p> <p>Check motor function by energizing circuit with the dispense button. If motor runs, but pump does not turn, a broken gear box is indicated. The pump motor and gear box are replaced as a unit.</p> <p>Check the direction of pump rotation...correct rotation is clockwise as viewed from the front of the unit. If pump is turning in a counter clockwise direction, this indicates the pump wires are reversed.</p> <p>Check the pump tubing for ruptures, wear, etc. Replace as needed following the instructions printed in this manual.</p>
<p><u>DISPENSER IS BRIXING OUT TOO HIGH.</u></p>	<p>Supply water pressure too low.</p> <p>Defective flow control.</p>	<p>Water pressure must be 20 psi flowing or above.</p> <p>Disassemble and check flow control assembly for binding, defective compensating spring , trapped debris. Be sure the spool moves freely within the sleeve, replace parts as needed.</p>

## *Troubleshooting Guide*

<b>Problem</b>	<b>Probable Cause</b>	<b>Remedy</b>
DISPENSER IS <u>BRIXING OUT TOO HIGH</u> . (Cont.)	Low viscosity or highly concentrated concentrate. Example 11 to 1 ratio.	Locate the pump switches grouped behind the front splash panel. They are marked SPEED SWITCH with the corresponding valve number. Placing the switch in the low position slows down the concentrate pumping rate requiring less water to brix.
DISPENSER IS <u>BRIXING OUT TOO LOW</u> .	<p>Supply water pressure is too high.</p> <p>Defective or improperly regulating flow control .</p> <p>Speed switch in the low position.</p> <p>Air leak in the concentrate suction line.</p> <p>Worn concentrate pump tubing.</p> <p>Defective poppet valve and or spring.</p>	<p>Water pressure has a high limit of 100 psi/ 7 bar or over. Place regulator in supply line to bring pressure down to 4 bar/ 50 psi flowing.</p> <p>High water pressure will cause the flow control not to regulate properly. If the problem exists after the pressure has been reduced to 50 psig/ 4 bar, the flow control maybe defective.. Disassemble and check the spool and sleeve function and the compensating spring . Replace parts as required.</p> <p>Pump speed switch is in the low position. Move switch to high increasing the pumping rate of the concentrate.</p> <p>Check that the concentrate line connection is secured tightly to the dispenser with the proper gaskets. Check the connector at the concentrate source to be sure it is properly attached.</p> <p>Remove the front half of the concentrate pump and inspect the tubing . Worn or stretched tubing will decrease the amount of concentrate pumped. After 1 year tubing should be replaced.</p> <p>Disassemble the right side of the valve which contains the syrup poppet assembly. Be sure the valve is not binding, free of debris, return spring is actuating and the diaphragm is not torn or punctured.</p>

## *Troubleshooting Guide*

<b>Problem</b>	<b>Probable Cause</b>	<b>Remedy</b>
<u>WATER LEAKS FROM BOTTOM OF DISPENSING VALVE.</u>	Nozzle pieces improperly assembled.	Static mixer inserted in nozzle body upside down. Cone shaped end must be visible when remounting the nozzle assembly to the dispenser.
<u>WATER CONTINUOUSLY DRIPS FROM NOZZLE.</u>	Water solenoid valve not shutting off tightly.	Disassemble water solenoid located at the valve and check for foreign material in the valve seat. Check the armature for binding, check the plunger and the seat for defects. Replace parts as needed.
<u>UNIT CONTINUES TO DISPENSE AFTER BUTTON HAS BEEN RELEASED.</u>	<p>Sticking or defective dispenser push button switch.</p> <p>Relay on voltage regulator board hangs up or is stuck open.</p> <p>Defective Voltage Regulator (VRB) Board.</p>	<p>Check the operation of the push button for sticking. Check continuity of switch. Replace as needed.</p> <p><b>CAUTION:</b> Access to this panel requires removal of the bonnet while the dispenser is plugged in and operational. *Voltage regulator board is found in the electrical box mounted to the refrigeration deck. There is one board for each valve. Gently tap the relay. If dispensing stops, relay was hung up . If tapping the relay solves the problem, it should be noted that if a relay sticks once , it will probably stick again. Replace as needed.</p> <p>Pull the connector marked DOOR , lower right hand connector on the VRB board. If the unit still continues to dispense the VRB board is defective and needs to be replaced.</p>
<u>TWO OR MORE PUMPS OPERATE WHEN ONLY ONE BUTTON IS PUSHED.</u>	Insulator pad missing or not properly positioned between the transistor on VRB board and mounting bracket.	On the valve that is dispensing in error, check the insulator pad between the transistor on the top of the VRB board and the mounting bracket. If this pad is missing or improperly aligned, the VRB board will make contact with the bracket. Current will run through the bracket and set off the valve. Refer to drawing found in this manual.



## *Troubleshooting Guide*

<b>Problem</b>	<b>Probable Cause</b>	<b>Remedy</b>
<p><u>TWO OR MORE PUMPS OPERATE WHEN ONLY ONE BUTTON IS PUSHED.</u> (Cont.)</p>	<p>VRB Board mounting screw insulator is missing or improperly installed.</p>	<p>Check the corresponding VRB board to the valve that is dispensing in error. Where the screw mounts the transistor to the bracket, be sure that the spacer bushing is present and the screw is not over tightened. Screw contact with the bracket will cause a short and the firing of the valve when other valves are energized.</p>
<p><u>WITH POWER PRESENT DISPENSER WILL NOT COOL</u></p> <p>Drink temperature should be 35-45°F 2-7°C</p>	<p>Refrigeration shut off switch is in the off position.</p> <p>Depleted ice bank (not applicable after period of heavy usage.)</p>	<p>Refrigeration shut off switch is located on the top of the dispenser. This switch will disable the compressor and condenser fan motor. Be sure the switch is in the on position.</p> <p>Remove rear bonnet covering the refrigeration deck. CAUTION should be observed when working in this area as the dispenser is energized and operational. Check to see if the compressor is running . If so allow the system to recover (approximately 1 hour).</p>
<p><u>WITH POWER PRESENT COMPRESSOR WILL NOT RUN.</u> (Compressor shell is cold to touch.)</p>	<p>Loose or broken wire connections.</p> <p>Defective compressor start component.</p> <p>Ice bank control not connected or defective.</p>	<p>Check the wire connections at the compressor. Be sure they are tightly secured.</p> <p>Check the compressor start relay. Replace as required.</p> <p>Check the ice bank control connections. To test, place jumper between the 2 leads. If the compressor starts ,the ice bank control is defective.</p>
<p><u>COMPRESSOR RUNS BUT NO COOLING IS TAKING PLACE.</u></p>	<p>Low refrigerant charge.</p> <p>Refrigerant restriction.</p>	<p>Contact a refrigeration service technician. They will check for leaks (sign of oil at joints and fitting) and will recharge if necessary.</p> <p>Refrigeration technician will examine the system for, kinks in lines, restrictions, etc. Heat exchanger may need to be replaced.</p>

## *Troubleshooting Guide*

<b>Problem</b>	<b>Probable Cause</b>	<b>Remedy</b>
<p><u>COMPRESSOR RUNS BUT NO COOLING. TRIPPING OVERLOAD.</u> (Compressor shell is hot to touch).</p>	<p>Condenser fan not running.</p> <p>Inadequate air flow through the dispenser.</p> <p>Blocked condenser fins.</p> <p>Ambient air over 100°F 38°C.</p> <p>Defective overload.</p> <p>Defective compressor.</p>	<p>Check that the condenser fan is running. If the fan is binding or turning slowly, an overload condition will occur.</p> <p>Air flow is top front in, exhaust out the rear. <b>NEVER PLACE ANYTHING ON TOP OF THE DISPENSER.</b> This will block the airflow over heating the compressor and causing it to trip the overload.</p> <p>Remove the rear bonnet and check the condenser fins. If unit is run in a dusty environment, condenser fins can become clogged, stopping the air flow. Brush out and clean with vacuum.</p> <p>If the dispenser is working in an environment over 100° ambient or is drawing in discharged air, during a heavy period, the unit may trip the overload.</p> <p>Overload works on shell temperature and amperage draw and can be defective. Replace as needed.</p> <p>Refrigeration technician will verify if the compressor is defective and needs to be replaced.</p>
<p><u>UNIT IS DISPENSING CONCENTRATE ONLY REFRIGERATION SYSTEM HAS BEEN RUNNING FOR EXTENDED PERIOD WITHOUT SHUTTING OFF FROZEN WATER COIL.</u></p>	<p>Insufficient water level in the water bath.</p> <p>Agitator motor not operating.</p> <p>Improperly located ice bank control sensor.</p>	<p>See the Start-up and Operation Section of this manual. Be sure the water bath is filled to fill line.</p> <p>Check the agitator motor located on the refrigeration deck. Be sure it is plugged in and receiving power. Check that the impeller is not obstructed. Replace if needed.</p> <p>Melt the ice bank and check the location of the sensing bulb. Be sure it is all the way down to the bottom of the tube.</p>

## *Troubleshooting Guide*

<b>Problem</b>	<b>Probable Cause</b>	<b>Remedy</b>
<u>UNIT IS DISPENSING CONCENTRATE ONLY</u> REFRIGERATION SYSTEM HAS BEEN RUNNING FOR EXTENDED PERIOD WITHOUT SHUTTING OFF <u>FROZEN WATER COIL.</u>	Compressor not cycling off.	Check the ice bank control. Be sure that the control has not overheated and fused the contacts together. Replace as required.

# Millennium 4 Valve Schematic

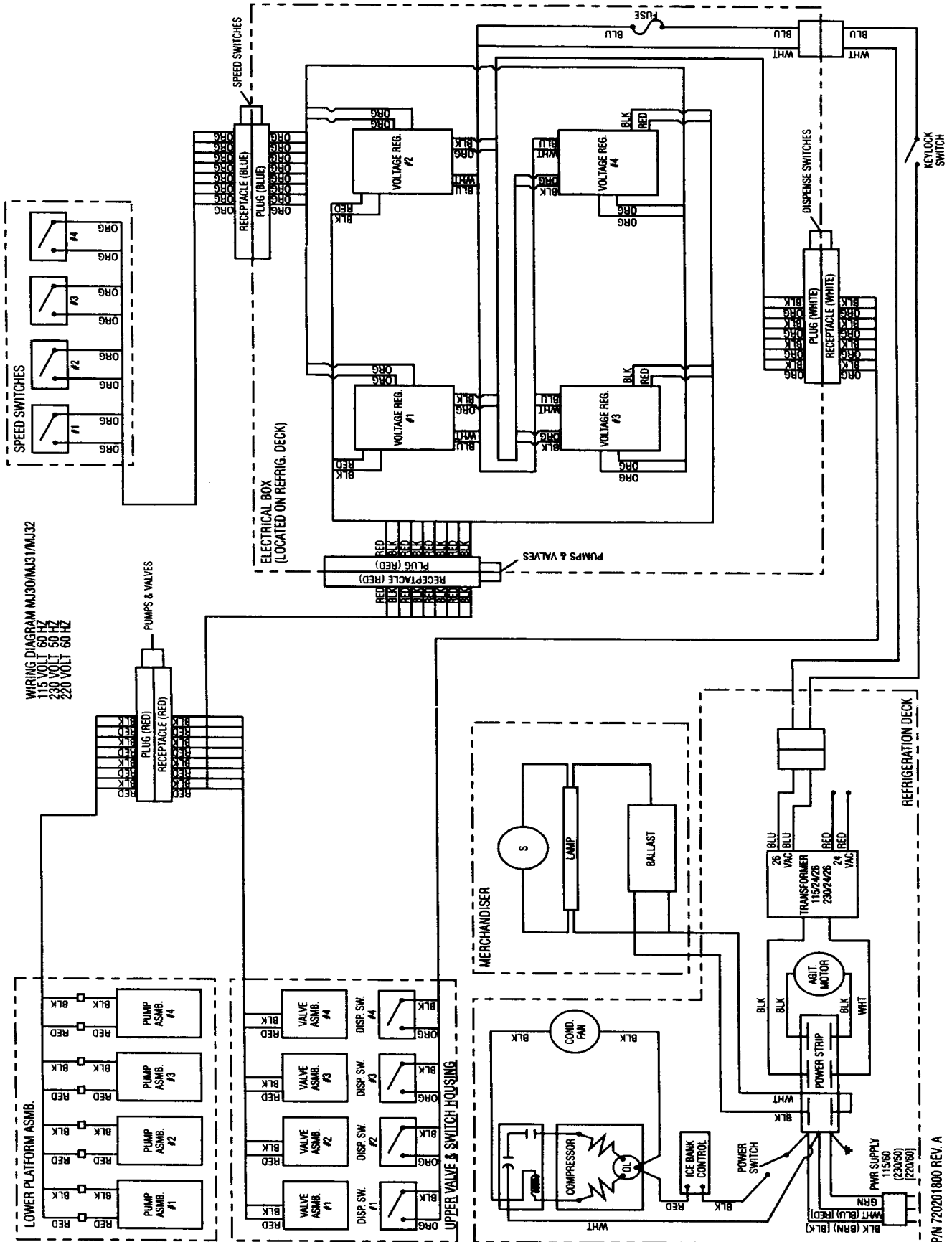

## ***Final Assembly***

***P/N 721210101 MJ30-4 PB (115V/60HZ)***

***P/N 721210102 MJ32-4 PB (230V/50HZ)***

***P/N 721210105 MJ31-4PB (220V/60HZ)***

<b>ITEM</b>	<b>PART NO.</b>	<b>DESCRIPTION</b>	<b>QTY</b>
1	50222	Merchandiser	1
2	720203000	Lens "Refreshing Drinks"	1
3	60064003	Fluorescent Bulb, F15T80 (All Voltages)	1
‡	350001	Ballast 115v/60hz	1
‡	60419006	Ballast 230v/50hz	1
‡	60420001	Starter 115v/60hz	1
‡	60419004	Ballast 220v/6hz	1
‡	350164	Socket, Starter	1
4	350061	Lamp Holder	2
5	231050	Reflector	1
6	231051	Wrapper, Stainless Steel	1
7	261142	Bonnet Assembly w/Screen	1
8	400325	Screw	2
9	720200500	Valve Adjustment Cover	1
10	720200400	Valve Enclosure	1
11	84353001	Push Button Switch Assembly	1
12	550088	Condenser	1
13	230509	Shroud	1
14	710160063	Handle	1
15	186074001	Ice Bank Control – All Voltages	1
16	350017	Condenser Fan Motor Blade	1
‡	350095	Condenser Fan Motor 115v/60hz	1
‡	350096	Condenser Fan Motor 220v, 230v/50hz, 60hz	1
17	40-0323	Screw	2
18	230040	Bracket, Agitator Motor	2
19	230303	Heat Sink, Agitator Motor	2
20	350078	Agitator Motor w/out Blade 115/60	1
‡	350079	Agitator Motor w/out Blade, 220v, 230v/50hz, 60hz	1
21	350012	Blade, Agitator	1
‡	36118	Spring Pin	1
23	400262	Plug Cap (Water Fill Hole)	1
24	260970*	Compressor 1/3 Hp R-134a 115v/60hz	1
‡	550001	Accumulator/Dryer	1
‡	350148	Compressor Start Relay 1/3 Hp 115v/60hz	1
‡	350108	Compressor Overload 1/3Hp 115v/60hz	1
‡	260968*	Compressor 1/3 Hp R-134a 230v/50hz	1
‡	350106	Compressor Overload 1/3 Hp 230v/50hz	1
‡	350151	Compressor Start Relay 1/3 Hp 230v/50hz	1
‡	260972*	Compressor 1/3 Hp R-134a 220v/60hz	1
‡	350146	Compressor Overload 1/3 Hp 220v/60 Hz	1
‡	350152	Compressor Relay 1/3 Hp 220v/60hz	1

\*-Compressor includes Relay, Overload, Grommets and Sleeves. Start Capacitor is required for 220V Compressors only and is supplied with the Compressor.

‡ -Indicates item not shown.

## *Final Assembly*

*P/N 721210101 MJ30-4 PB (115V/60HZ)*

*P/N 721210102 MJ32-4 PB (230V/50HZ)*

*P/N 721210105 MJ31-4PB (220V/60HZ)*

ITEM	PART NO.	DESCRIPTION	QTY
‡		Compressor Start Capacitor 220v/60hz	1
25	350115	Hitch Pin	4
26	400407	Washer	4
27	350055	Grommet	4
28	350158	Sleeve	4
‡	350182	Power Switch, Refrigeration Deck	1
29	720202200	Transformer Assembly 115v/60hz	1
‡	720202201	Transformer Assembly 220v, 230v/50hz, 60 Hz	1
30	720201400	Electrical Box Assembly (All Voltages)	1
31	720201403	Cover, Electrical Box	1
32	710160156	Refr. Deck Assembly 115v/60hz (w/out Ele. Box & Transformer)	1
‡	710160159	Refr. Deck Assembly 230v/50hz (w/out Ele. Box & Transformer)	1
‡	710160157	Refr. Deck Assembly 220v/60hz (w/out Ele. Box & Transformer)	1
33	350130	Power Strip	1
34	260061	Bulb Holder	1
‡	230983	Bracket, Bulb Holder	1
35	261135	Cabinet Assembly (Includes Items 47 & 48)	1
36	350174	Clip	2
37	350131	Main Power Cord	1
38	400501	Elbow 25 MPTX.5B Nylon	1
39	650094	Vinyl Tubing 1/2" ID Overflow	
40	720200700	Splash Panel	1
41	720200300	Dispensing Assembly	1
42	720200200	Enclosure Assembly (with Speed Switch Mtg Plate)	1
43	27615	Key Switch with Keys	1
‡	19578	Key, Double Sided #2009	2
44	720200600	Cup Rest	1
45	720200100	Drain Pan	1
46	89043	Vinyl Tubing	6 Ft
47	231049	Front Panel, Base Riser	1
48	261136	Base Riser Assembly	1
50	261137	Water Coil Assembly	1
51	230208	Bracket	1
52	400193	Flare Nut	1
53	48033002	Nylon Washer	1
54	400135	Coupler	1
‡	261139	Water Manifold Assembly 4 Valve	1
‡	400113	Fitting El-Barb 3/8 x 1/4 MPT	1
‡	400263	Dead Head Plug	1
‡	650089	Drain Hose	3 Ft

\*-Compressor includes Relay, Overload, Grommets and Sleeves. Start Capacitor is required for 220V Compressors only and is supplied with the Compressor.

‡ -Indicates item not shown

# Final Assembly

P/N 721210101 MJ30-4 PB (115V/60HZ)  
P/N 721210102 MJ32-4 PB (230V/50HZ)  
P/N 721210105 MJ31-4PB (220V/60HZ)

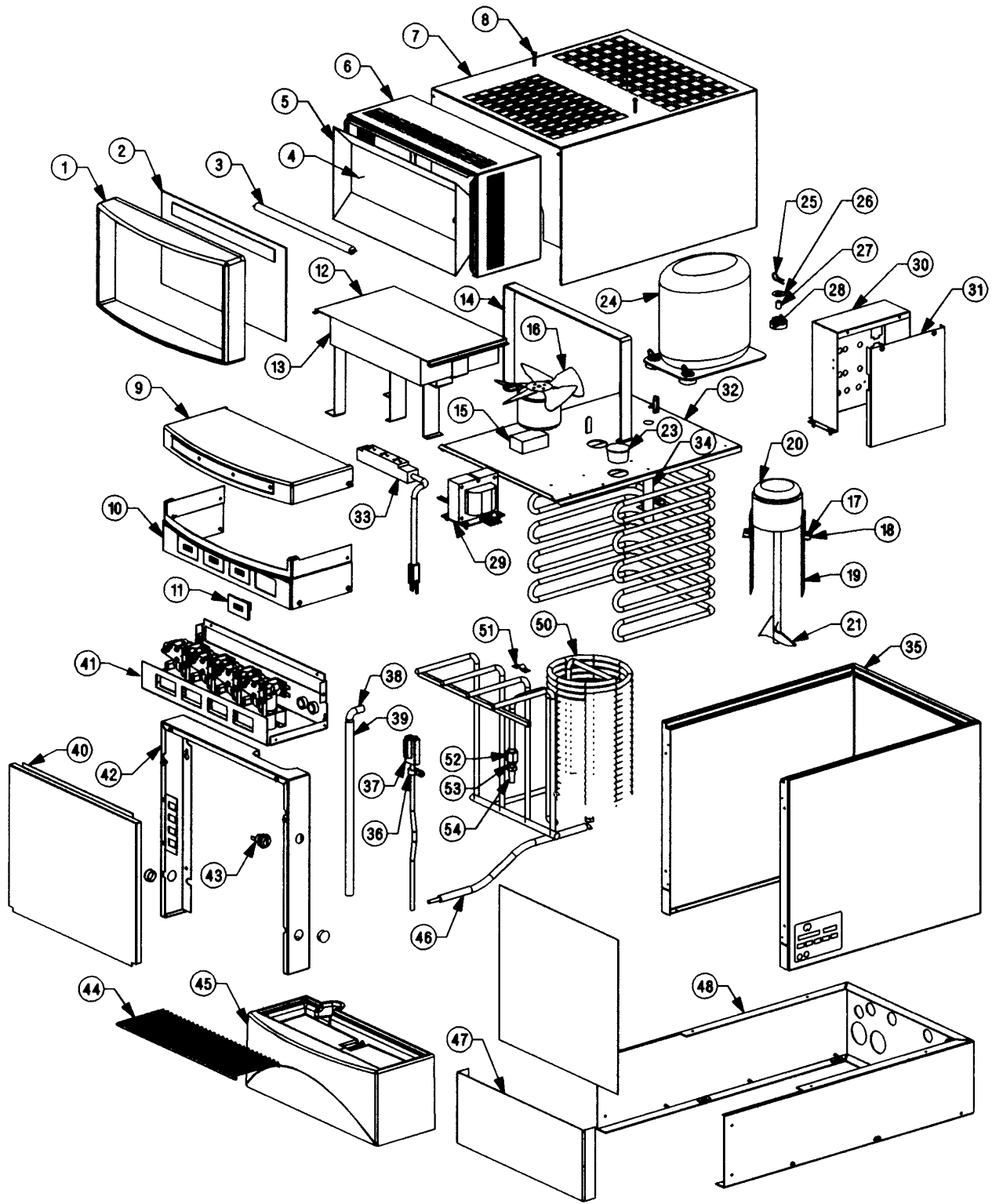

# Platform Assembly

P/N 720200800

ITEM	PART NO.	DESCRIPTION	QTY
1	720200804	Tube Fittings/Bracket Assembly	1
2	720200801	Base, Pump	1
3	720200802	Bracket, Pump Support	1
4	48432	Pump & Bracket Assembly Millennium	4
5	720201600	Harness Assembly, Pumps to Plug	1
6	48195006	Clamp-Hose, .470"- .XXX" I.D.	8
7	48309	Tube Assembly, Pump Inlet	4
8	48310	Tube Assembly, Valve Inlet	4
9	89078	Tubing-Beverage, 3/8 I.D. Redline	2.3'
10	48114004	Clamp-Ear, 105 (.413/.346)	4
11	48114003	Clamp-Ear, 145 (.571/.472)	2
12	0734801	Rivet, Pop	4
13	0704001	Screw, #8-32 Type "F" BD HD, 3/8" LG	10
14	0733903	Bushing-Snap	2
15	55145	TY-Wrap 5 1/2" Long	2

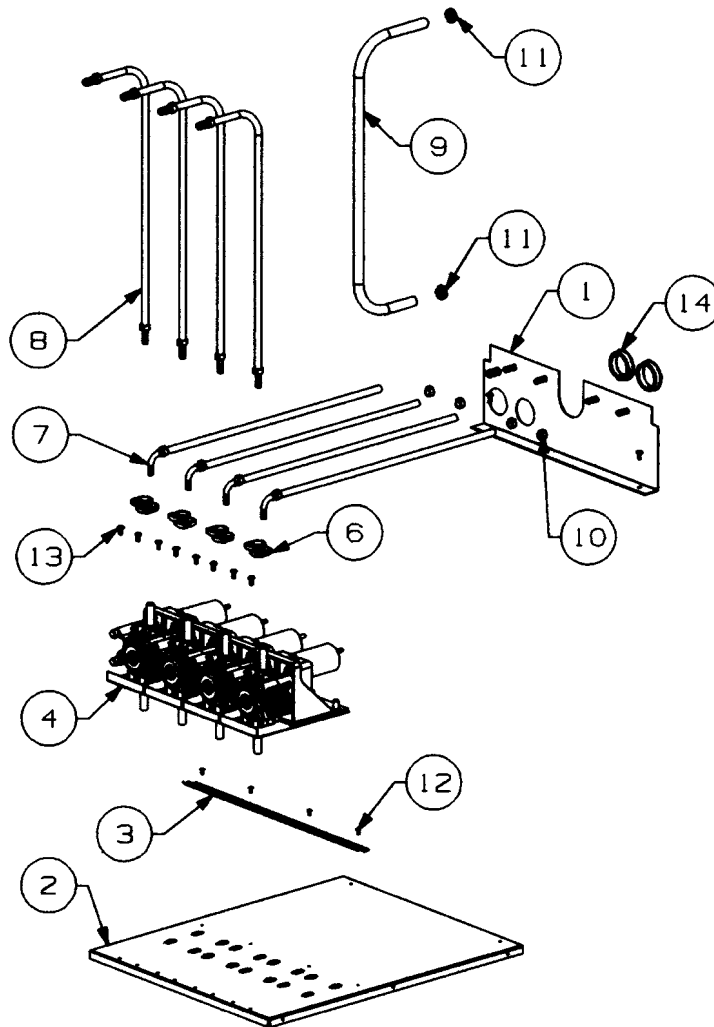



# Pump & Bracket Assembly

P/N 48432

ITEM	PART NO.	DESCRIPTION	QTY
1	0704105	Screw, 8-32 x 1/2"	4
2	45185	Pump & Motor Assembly	1
3	45283	Rubber Bushing With Nut Insert	4
4	48420	Pump Bracket	1

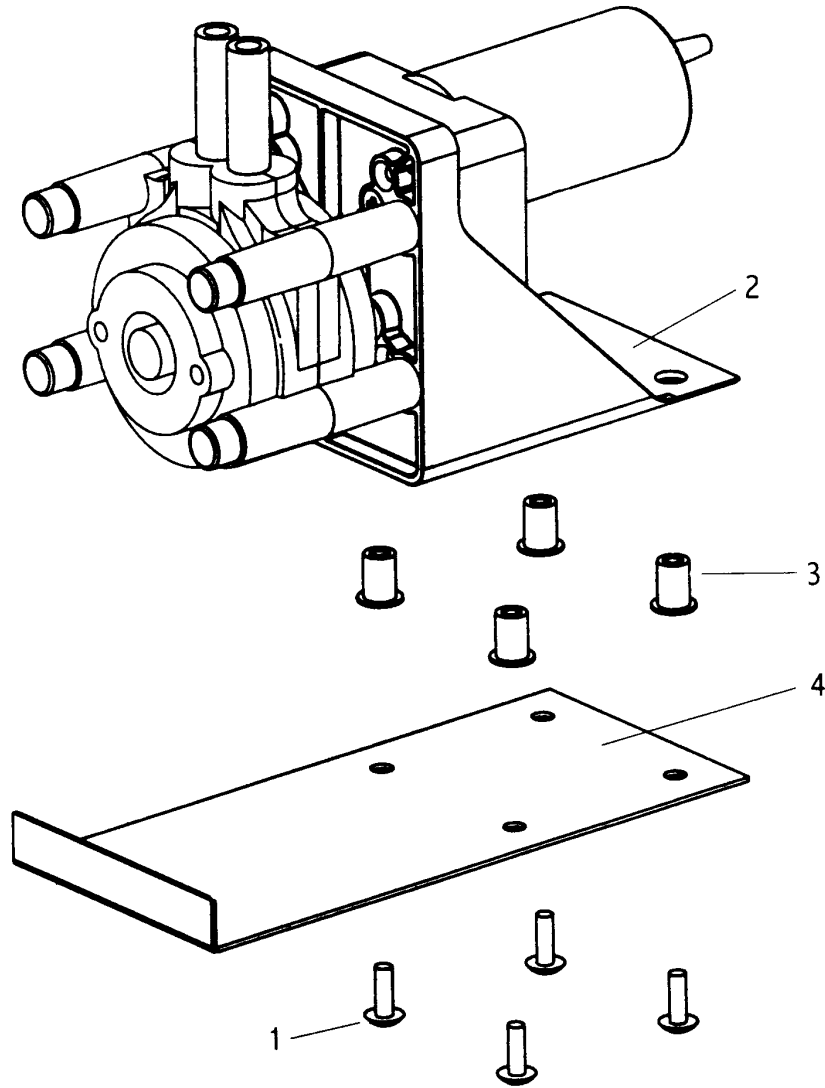

# Pump Motor Assembly

P/N 48405

ITEM	PART NO.	DESCRIPTION	QTY
1	45016001	Pump Motor with Boot (Item #7)	1
2	45078	Pump Complete, 3-Roller	1
3	45050	Block Assembly, Pump & Motor	1
4	45017001	Thumbscrew	4
5	0702905	Screw, 8-32 x 3/4"	1
6	45098	Tubing Kit (1 Pre-Cut Tube and 2 Clamps)	4
7	45074	Boot-Pump Motor	1

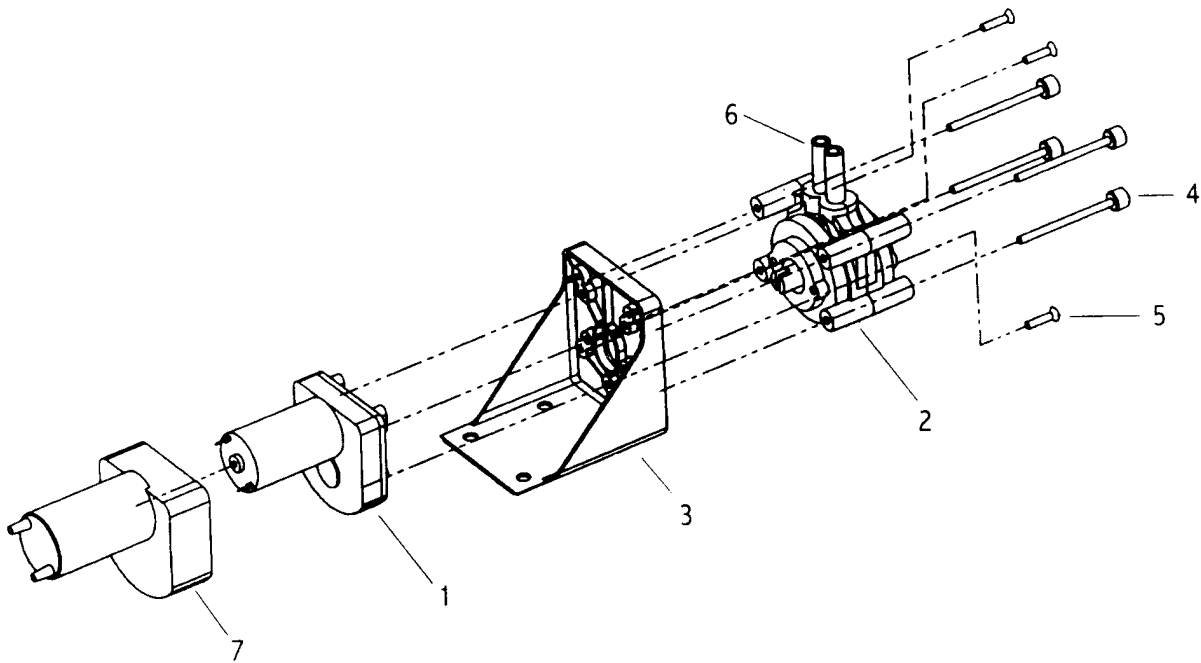

# Dispensing Assembly

P/N 720200300

ITEM	PART NO.	DESCRIPTION	QTY
1	0704107	Screw, *8-32 THMS, 5/8" LG	8
2	45027001	Bushing-Nozzle, SL Juice Dispense	4
3	07033901	Bushing-Snap	2
4	48415	Valve Block/Bracket Assembly	4
5	720200301	Support, Valve Block	1
‡	45123	Static Mixer	4
‡	31525-057	O-Ring Mixing Nozzle 13/16 O.D. x .676 I.D.	4
‡	45003-001	Mixing Nozzle with O-Ring	4

‡ -Indicates item not shown

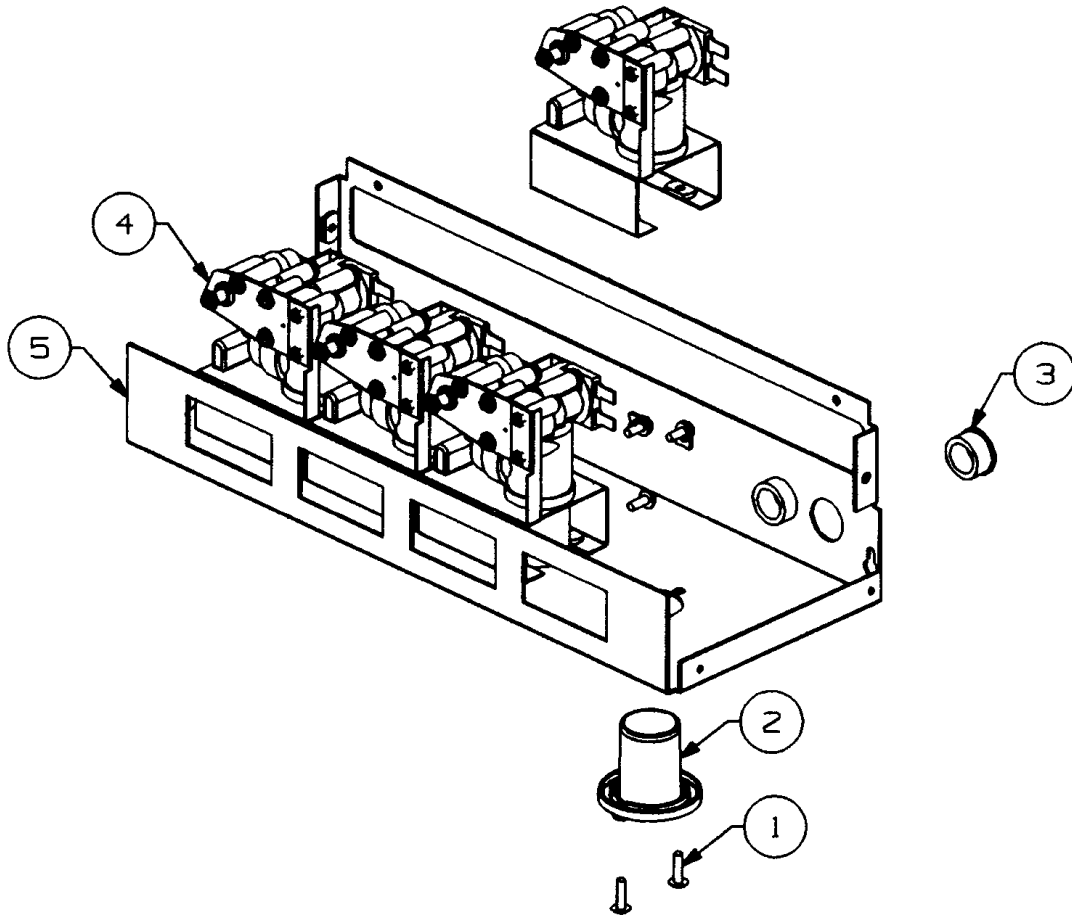

# *Valve Block Assembly*

*P/N 45045*

<b>ITEM</b>	<b>PART NO.</b>	<b>DESCRIPTION</b>	<b>QTY</b>
1	45177	Holder, Poppet Seal	1
2			
3	0720406	Nut, #10-32 KEPS	1
4	15321	Ring-Retain, .242 ID	1
5	15323	Armature-EL VLV	1
6	18070	Gasket-Rubber 1.055 DIA	1
7	18367	Spring-Coil, SS	1
8	19695001	Guide-AS Small ELVL	1
9	31525021	O-Ring, 1-1/4 OD x 1.114 ID	1
10	18071	Seat-Armature Water, FFV	1
11	48258005	Spring-Syrup, FFV	1
12	45192	Valve Body, Mixing	1
13	45193	Valve Block-Water, SL Juice	1
14	45029	Plate-Coil Retainer	1
15	47011	Diaphragm W/Hole-Valve, MDJ	1
16	45180	Spring Actuator-SLJ1000	1
17	45189	Armature Tip	1
18			
19	47048	Support-Diaphragm, MDJ	1
20	45195	Valve Block, Front Plate	1
21	45186	Spring - .360 OD x .032 Wire	1
22	31525060	O-ring, .539" x .459" x .875" OD	1
23	48520001	Coil Assembly, -24 V DC	1
24	48978	Flow Control/Bonnet Assembly, -FFV	1
25	60280002	Piston-Water, Ceramic, FFV	1
26	07032001	Screw, #8-18 x 7/16 Type "25" HHWF SS	13
27	60281001	Sleeve-Syrup, Ceramic, FFV	1
28	16779003	Frame - "C" Solenoid	1
29	27408	Petro-Gel	1
30	49612	Valve Port - Water	1
31	31525020	O-Ring, 5/16" OD x .176" ID	1
32	22081	Washer-Holddown EVLV	2

# Valve Block Assembly

P/N 45045

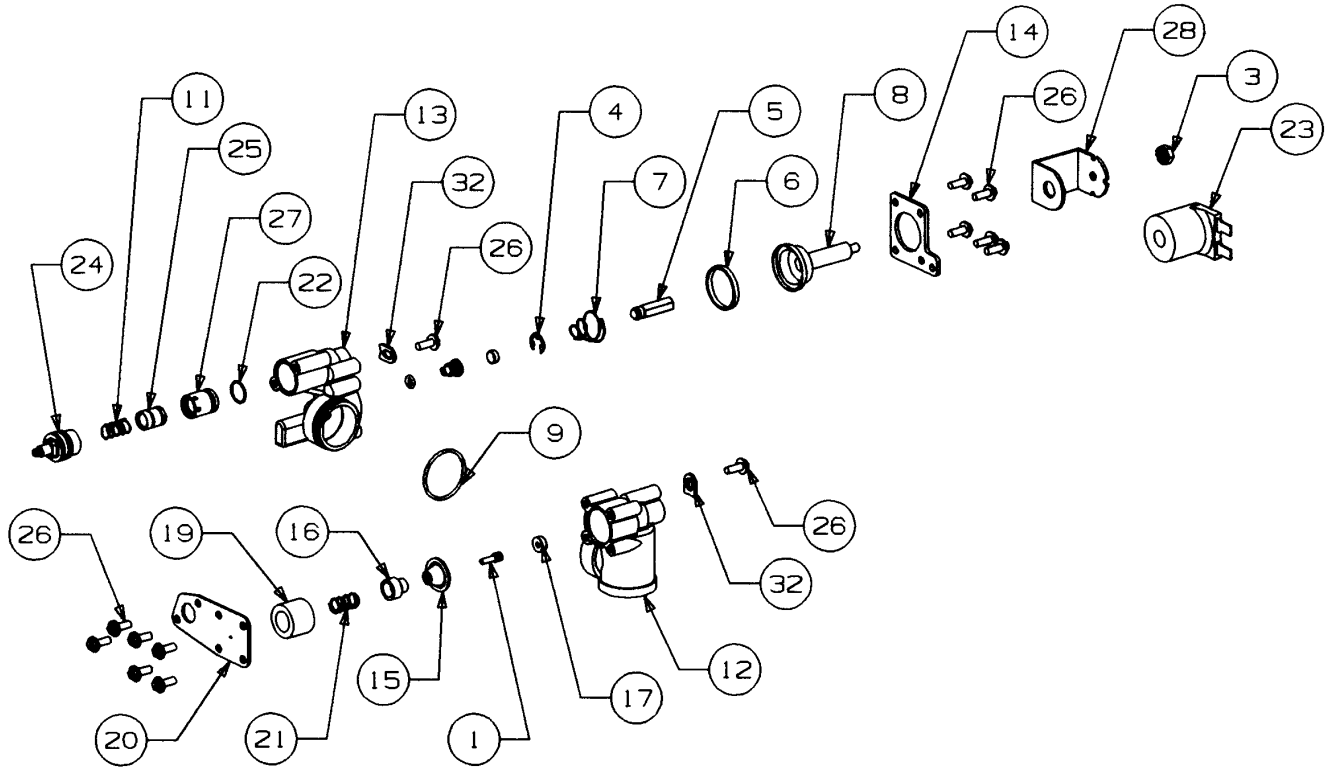

# Electrical Box Assembly

P/N 720201400

ITEM	PART NO.	DESCRIPTION	QTY
1	45238	Voltage Regulator Assembly, SLJ1000-2	2
2	720201401	Enclosure, Electrical	1
3	720201403	Cover, Electrical Box	1
4	0734801	Rivet, Pop	1
5	0704001	Screw, #8-32 Type "F" BD HD, 3/8" LG	7
6	59328001	Fuse – 6.25 Amp, 250 V, SL Juice Dispenser	1
7	45059	Fuse Holder	1 </td
8	720201701	Wiring, Assembly Pumps to E-Box	1
9	720201702	Harness Assembly, Speed Switches E-Box 4 FL	1
10	720201703	Harness Assembly PB Switches E-Box 4 Flavor	1
11	720201704	Harness Assembly Power E-Box 4 Flavor Millennium	1

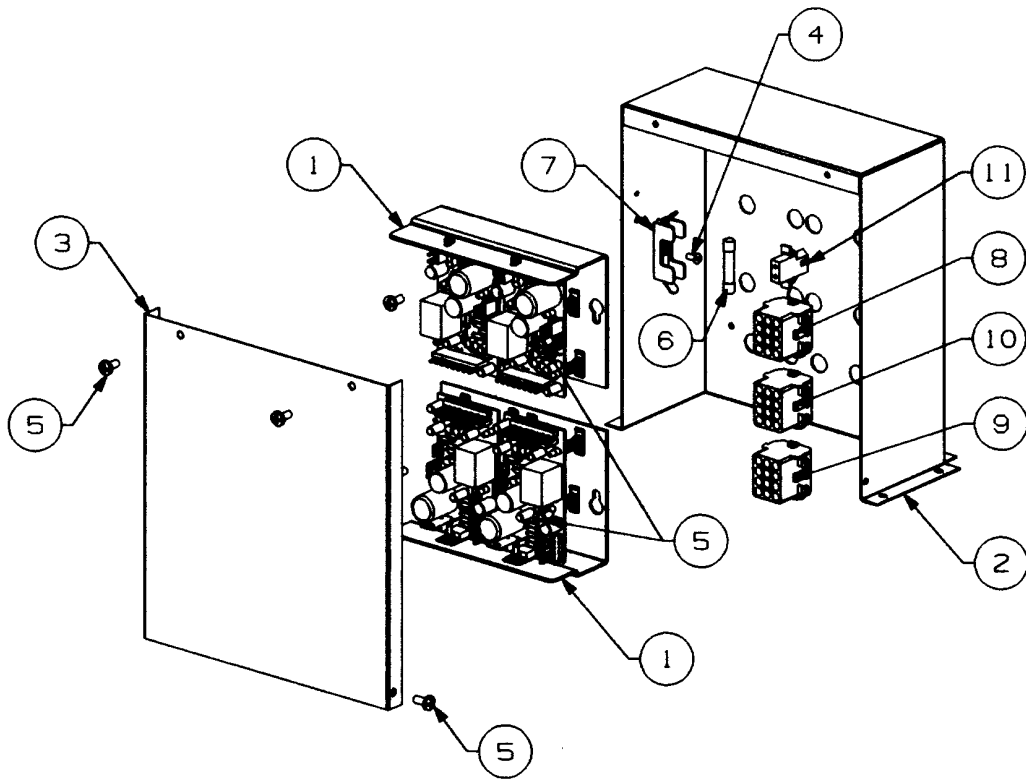

# Voltage Regulator Assembly, SLJ1000-2

P/N 45238

ITEM	PART NO.	DESCRIPTION	QTY
1	45162	Bracket-Voltage Regulator, SLJ1000-1	1
2	45056	Support-PC Board, SL Juice	8
3	45012002	Board-Voltage Regulator, SLJ	2
4	45613	Fastener, Plastic -VRB Mtg	2
5	45004001	Insulator-Voltage Regulator	2

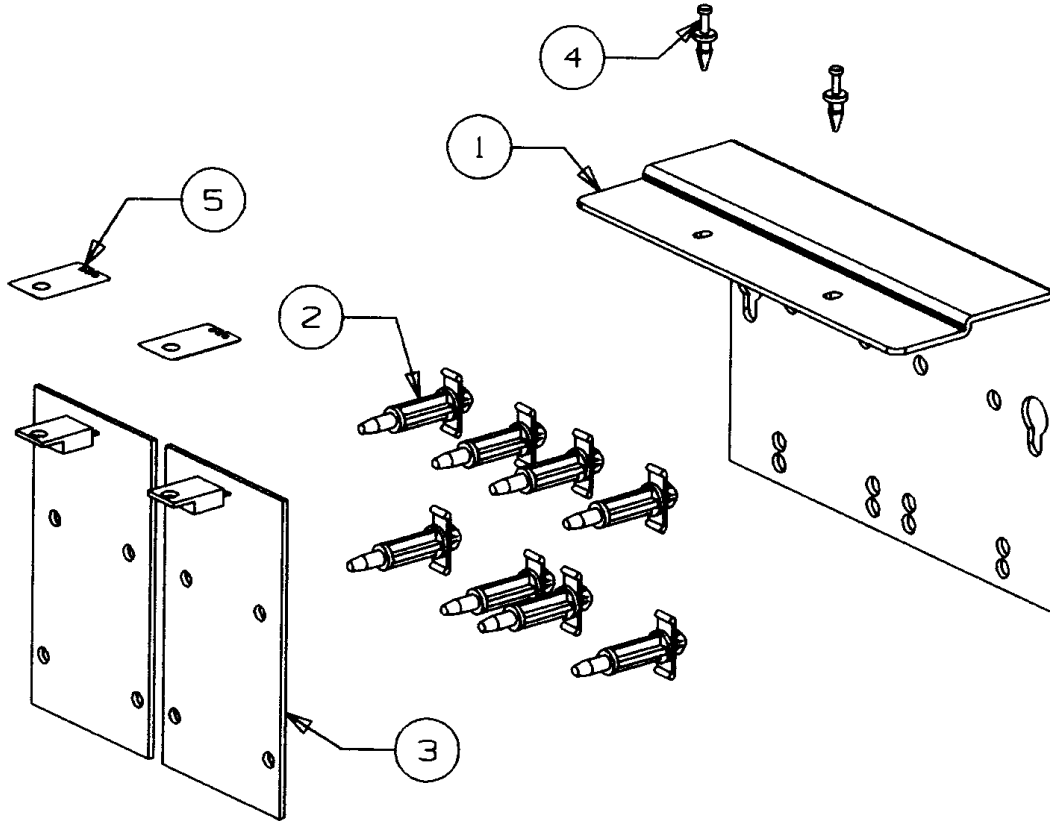

***Millennium Model MJ30-4***  
***Recommended Spare Parts List***

(For 10 Dispensers)

<b>PART NO.</b>	<b>DESCRIPTION</b>	<b>QTY</b>
45003100	Nozzle & O-Ring Assembly	4
45123	Static Mixer (inside disp. nozzle)	4
31525037	O-Ring, Dispensing Nozzle	4
45189	Poppet, Rubber, Valve Mixing Block	4
45177	Poppet Seal Holder	4
47011	Diaphragm with Hole, Valve Mixing Block	4
45180	Spring Actuator, Valve Mixing Block	4
45186	Spring, Valve Mixing Block	4
45179	Diaphragm, Support, Valve Mixing Block	4
18070	Gasket, Rubber, Water Solenoid	4
15323	Armature Water Solenoid	4
18071	Armature Seat	4
18367	Spring, Coil, S/S, Water Solenoid	4
15321	Ring, Retaining, Water Solenoid	4
31525020	O-Ring, Water Solenoid Valve	4
31525021	O-Ring, Valve Mixing Block	4
48520001	Coil, Water Solenoid, 24 VDC	2
60280002	Piston, Ceramic, Brix Control	3
60281001	Sleeve, Ceramic, Brix Control	3
31525060	O-Ring, Ceramic Sleeve	3
48258005	Spring, Brix Control	3
48978	Flower Control, Bonnet Assembly	3
84353001	Push Button, Dispense	4
45012102	Circuit Board, Voltage Regulator	2
48448	Transformer Assembly 115V/60Hz	1
45432	Switch, Rocker, Speed Adjustment	2
59328001	Fuse, 6.25 Amp, 220 VAC	2
45016001	Pump Gear Motor	1
45098	Pump Tubing Kit (pre-cut tube with clamps)	3
186074001	Ice Bank Control	1
350095	Motor, Condenser, 115V/60Hz	1
350078	Agitator Motor Assembly, 115V/60Hz (w/blade)	1
350148	Relay, Compressor, 115V/60Hz	1
350108	Overload, Compressor, 115V/60Hz	1
60064003	Bulb, Fluorescent	1
350001	Ballast 115v/60Hz	1
350164	Starter 115V/60Hz	1
720200100	Drain Pan Assembly	1
720200600	Cup Rest	1



## ***Millennium Model MJ30-4 Optional Accessories***

The following options are available for the Millennium Dispenser. For more information, please contact our customer service department at 1-800-344-3801 Monday-Friday between the hours of 8:00 a.m. and 4:30 p.m. CST.

<b>Part No.</b>	<b>Description</b>
721900000	Optional Leg Kit Standard (set of 4 steel legs and 2 support braces)
721900001	NSU Kit (secures unit for use on ships)
721900002	Kit Leg Adjustable
48350007	Single, 2 Button Bar Gun Kit
48350008	Dual 2 Button Bar Gun Kit

# IMI CORNELIUS INC.

## *Certificate of Warranty*

### **ONE YEAR LIMITED PARTS EQUIPMENT WARRANTY**

IMI Cornelius Inc. warrants to the original commercial purchaser/user, that any commercial product of its manufacture bearing the name "Wilshire" will be free from defect in material and/or factory workmanship, and that if properly installed, maintained, and serviced in accordance with the *Service Manual* furnished with the product, it will perform adequately under normal use. This product warranty shall be effective for a period of one year from the date of original installation or 15 months from the date of original shipment by IMI Cornelius, whichever period elapses first.

IMI Cornelius Inc.'s obligation, upon return of the part or parts to its factory, transportation charges prepaid, is limited strictly to replacing or to repairing without charge any part or parts IMI Cornelius finds to be defective in material and/or factory workmanship during the warranty period. The serial and model numbers and date of original installation of the product must be given. No part or assembly which has been subject to accident, alteration or misuse or which is not installed, maintained, or serviced in accordance with the Service Manual furnished with the product, or which is from a machine on which the serial number has been removed, shall be covered by this warranty. This warranty does not provide for service calls from factory representatives or from any other agencies and shall not include charges of any nature.

IMI Cornelius Inc. will accept a part, parts, or equipment freight prepaid and return same freight collect to the sender within the continental U.S. or port of export within the continental limits of the U.S. IMI Cornelius Inc. is not responsible for international freight, customs fees or duties at country of destination.

### **ADDITIONAL FOUR YEAR LIMITED WARRANTY ON COMPRESSOR**

This warranty shall be effective for a period of four (4) years from the expiration of the above warranty.

The hermetically sealed refrigeration compressor is covered by the above one year limited warranty. In addition to that warranty, if the compressor fails because of a defect in materials or workmanship during the second through fifth year from the date of installation, IMI Cornelius Inc. will repair or, at its option, replace the compressor. Labor charges and the cost of relays, overloads and capacitors are not included.

THIS WARRANTY DOES NOT COVER DAMAGE CAUSED BY LACK OF PREVENTATIVE MAINTENANCE, IMPROPER INSTALLATION, ACCIDENT, MISUSE, NEGLIGENCE, ALTERATION, FIRE, FLOOD, OR ACTS OF GOD.  
In those jurisdictions where liability for damages cannot be disclaimed, original purchasers recovery shall not exceed the cost of the warranted product.

IMI CORNELIUS INC. ASSUMES NO LIABILITY FOR INCIDENTAL OR CONSEQUENTIAL DAMAGES OF ANY KIND, INCLUDING, BUT NOT LIMITED TO, SPOILED PRODUCT, LOST PROFITS, OR DAMAGE TO OTHER PROPERTY.

THIS WARRANTY IS EXCLUSIVE AND IN LIEU OF ALL OTHER WARRANTIES, WHETHER WRITTEN, ORAL, OR IMPLIED, INCLUDING ANY WARRANTY OF MERCHANTABILITY OR FITNESS FOR A PARTICULAR PURPOSE, AND SUPERSEDES AND EXCLUDES ANY ORAL WARRANTIES OR REPRESENTATIONS OR WRITTEN LANGUAGE IN ANY MANUAL, LITERATURE, ADVERTISING BROCHURE OR OTHER MATERIALS NOT EXPRESSLY DESIGNATED IN WRITING AS A "WARRANTY".



**IMI Cornelius**

One Cornelius Place  
Anoka, Minnesota 55303  
612-421-6120 / 800-238-3600  
612-422-3255



# *Notes*

