

PLEASE READ AND SAVE THESE INSTRUCTIONS. Read carefully before attempting to assemble, install, operate or maintain the product described. Protect yourself and others by observing all safety information. Failure to comply with instructions could result in personal injury and/or property damage! Retain instructions for future reference.

Dayton® Portable Residential Air Conditioner

Description

The Dayton compact heavy duty Portable Residential Air Conditioner equipped with Remote Control containing batteries, produces low decibels while delivering maximum cooling output. The unit features Even Air Distribution through auto swing louvers. Ideal for spot cooling applications in small areas such as, small work areas, homes, offices or IT equipment and server areas.

Unpacking

Handle carefully. Check the packing list to account for all items. Visually inspect for shipping damage. If damaged, immediately file a claim with the carrier.

Specifications

AIR CONDITIONER

Models 5EAK0 and 5EAK1
 Volts/Hz 115V, 60 Hz
 BTU/Hour (5EAK0) 8,100
 BTU/Hour (5EAK1) 10,000
 Operating Temp. Ranges:
 Cool 17~32°C (62~92°F)
 Dehumidify 13~32°C (54~92°F)

Dimension 33¹/₁₆" x 19¹/₁₆" x 16²/₁₆"

General Safety Information

READ AND SAVE THESE INSTRUCTIONS

MOBILE TYPE AIR CONDITIONER

⚠ WARNING *This air conditioner has no ventilator for taking in fresh air from out of doors. You must open doors or windows frequently when you use gas or oil heating appliances in the same room, which consume a lot of oxygen from the air. Otherwise, there is a risk of suffocation in extreme cases.*

1. Do not use in the following locations:
 - a. Next to source of fire.
 - b. An area where oil is likely to splash.

- c. An area exposed to direct sunlight.
 - d. An area where water is likely to splash.
 - e. Near a bath, a shower or a swimming pool.
 - f. In a green house.
2. Never insert your fingers or any foreign objects into the air outlet. Take special care to warn children of these dangers.
 3. Always store unit in upright/vertical position, preventing damage to the compressor system.
 4. Be sure to unplug the unit before cleaning.
 5. The unit exhaust must never be located near or in front of the socket outlet.
 6. If the appliance is covered, there is a risk of overheat.
 7. Do not operate this unit if it has a damaged cord or plug or if it is not working properly, or has been dropped or damaged in any manner. If damaged take the unit to the nearest authorized service facility for examination, repair or electrical/mechanical adjustment.

⚠ WARNING *If the supply cord is damaged, it must be replaced by the manufacturer or its service agent or a similarly qualified person in order to avoid a hazard.*



Figure 1 – Portable Residential Air Conditioner with Remote Control

NOTE: The following contents apply only to countries in Europe.

⚠ WARNING *Do not dispose of this product as unsorted municipal waste. Collection of such waste separately for special treatment is necessary.*

8. It is prohibited to dispose of this appliance in domestic household waste. For disposal, there are several possibilities:
 - a. The municipality has established collection systems, where electronic waste may be disposed of free of charge to the user.
 - b. As old products contain valuable resources, they can be sold to scrap metal dealers.

E
N
G
L
I
S
H

E
S
P
A
Ñ
O
L

F
R
A
N
Ç
A
I
S

Dayton® Portable Residential Air Conditioner

ENGLISH

General Safety Information (Continued)

CAUTION Careless disposal of waste in forests and landscapes endangers your health when hazardous substances leak into the ground-water and find their way into the food chain.

REMOTE CONTROLLER

WARNING Be sure there are no barriers between the remote controller and the receiver of indoor unit otherwise the air conditioner will not work.

1. Keep the Remote Controller away from all liquids.
2. Protect the Remote Controller from high temperatures and exposure to radiation.
3. Keep the indoor receiver out of direct sunlight or the Air Conditioner may malfunction.
4. Keep controller away from EMI (Electro-Magnetic Interference) supplied by other household appliances.

Features

COMPONENT PARTS

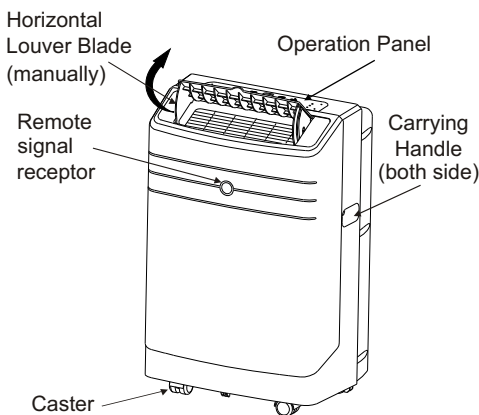

Figure 2 – Front and Side View

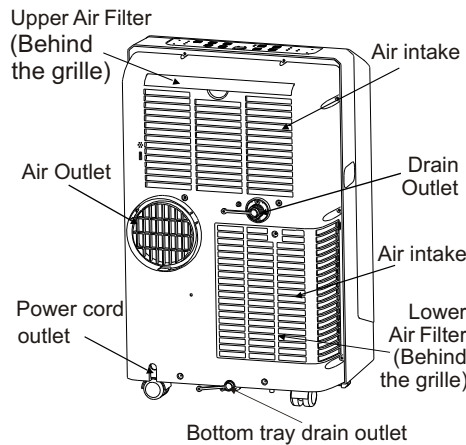
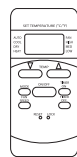

Figure 3 – Back View

ACCESSORIES

1. Remote Control



2. Battery (2 pc.) (for remote controller)



3. Exhaust Duct



4. Adaptor A (for temporary duct mounting)



5. Window Slider Kit



6. Foam Seal (3 pc.)



NOTE: Check to see that all the accessories are included in the package and refer to the installation instructions for their usage.

NOTE: The rating data indicated on the energy label is based on the testing condition of installing the unextended air exhaust duct without adaptor A.

Installation

WINDOW KIT INSTALLATION

Your window kit has been designed to fit most standard "Vertical" and "Horizontal" window applications. However, it may be necessary for you to improvise/modify some aspects of the installation procedures for certain types of window. Please refer to Figures 4 and 5 for minimum and maximum window openings.

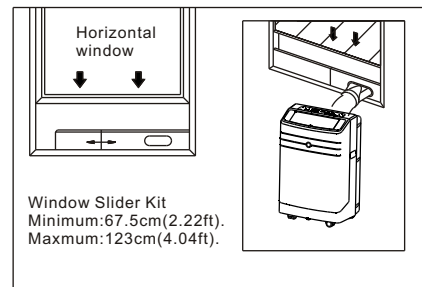

Figure 4 – Minimum and Maximum Window Openings

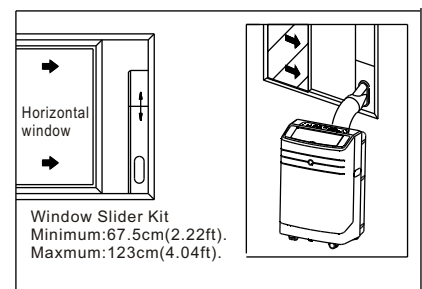

Figure 5 – Minimum and Maximum Window Openings

Models 5EAK0 and 5EAK1

Installation (Continued)

NOTE: If the window opening is less than the above mentioned minimum length of the window slider kit, cut that one with a hole in it short to fit the window opening. Never cut out the hole in window slider kit.

IMPORTANT: Install the mobile air conditioner in a flat and spacious location where the air outlets will not be covered up. A minimum clearance of 12 inches shall be maintained from wall or other obstacles. This air conditioner should never be used in a laundry room. The electrical 5-15P plug should always be accessible after unit has been positioned.

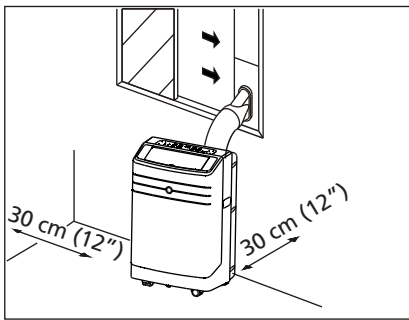

Figure 6 – Minimum Wall Clearance

DUCT MOUNT INSTALLATION

The exhaust hose and adaptor must be installed or removed in accordance with the usage mode.

COOL mode	Install
FAN or DEHUMIDIFY mode	Remove

1. Install the window exhaust onto the exhaust hose as shown in Fig.7. Refer to the previous pages for window kit installation.
2. Place the Exhaust hose over against the air outlet opening hook and flat the other end for quick installation.

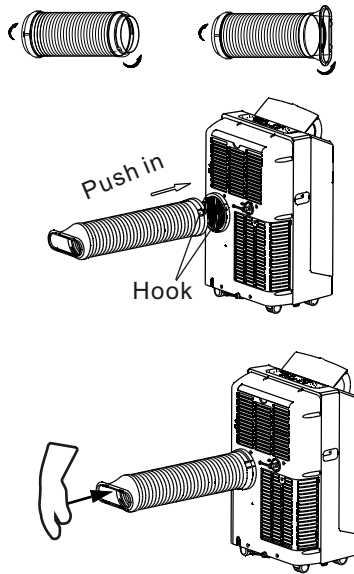

Figure 7 – Attaching Adaptor and Duct

NOTE: The duct can be compressed or extended moderately according to the installation requirement, but it is desirable to keep the duct length to a minimum.

Operation

AIR CONDITIONER

Before starting this unit:

1. Select a suitable location, make sure you have easy access to an electrical outlet.
2. Install the flexible exhaust hose and the adjustable window slider kit as depicted in Figures 8 and 9.



Figure 8

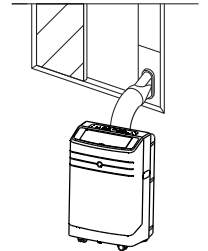

Figure 9

NOTE: Step 2 is required only while using the cooling mode.

3. Plug the unit into a 115V~60Hz (refer to the nameplate located on the right side of the unit) grounded electrical outlet. **DO NOT USE A STANDARD EXTENSION CORD.** If it is necessary to use an extension cord with this unit, use an approved heavy duty air conditioner extension cord **ONLY**.
4. Insert the power cord fixing strap into the hole in the back of the unit, and bundle up the excess cord.
5. Make sure the water tank is correctly positioned inside the cabinet otherwise the unit will not operate.
6. Press the "POWER" button to turn on the unit.

Dayton® Portable Residential Air Conditioner

Operation (Continued)

ELECTRICAL REQUIREMENT

1. All wiring must comply with local and national electrical codes and be installed by a qualified electrician. If you have any questions regarding the following instructions, contact a qualified electrician.
2. Check available power supply and resolve any wiring problems BEFORE installation and operation of this unit.
3. For your safety and protection, this unit is grounded through the power cord plug when plugged into a matching wall outlet. If you are not sure whether the wall outlets in your home are properly grounded, please consult a qualified electrician.
4. The manufacturers nameplate is located on the right side panel of the unit and contains electrical and other technical data specific to this unit.
5. To avoid the possibility of personal injury, always disconnect the power supply to the unit before installing and/or servicing.

COOL operation

1. Press the "MODE" button until the "COOL" indicator light comes on.
2. Press the ADJUST buttons "▲" or "▼" to select your desired room temperature. The temperature can be set within a range of 17°C-30°C/62°F-88°F.
3. Press the "FAN SPEED" button to choose the fan speed.

HEAT operation

(cooling only models without)

1. Press the "MODE" button until the

"HEAT" indicator light comes on.

2. Press the ADJUST buttons "▲" or "▼" to select your desired room temperature. The temperature can be set within a range of 17°C-30°C/62°F-88°F.
3. Press the "FAN SPEED" button to choose the fan speed. For some models, the fan speed can not be adjusted under HEAT mode.

DRY operation

1. Press the "MODE" button until the "DRY" indicator light comes on.
2. Under this mode, you cannot select a fan speed or adjust the temperature. The fan motor operates at LOW speed.
3. Keep windows and doors closed for the best dehumidifying effect.
4. Do not put the duct to window.

AUTO operation

1. When you set the air conditioner in AUTO mode, it will automatically select cooling, heating (cooling only models without), or fan only operation depending on what temperature you have selected and the room temperature.
2. The air conditioner will control room temperature automatically round the temperature point set by you.
3. Under AUTO mode, you can not select the fan speed.

FAN operation

1. Press the "MODE" button until the "FAN" indicator light comes on.
2. Press the "FAN SPEED" button to choose the fan speed. The temperature cannot be adjusted.
3. Do not put the duct to window.

TIMER operation

1. When the unit is on, first press the Timer button, the TIMER OFF indicator light illuminates. It indicates the Auto Stop program is initiated.
2. When the unit is off, first press the Timer button, the TIMER ON indicator light illuminates. It indicates the Auto Start program is initiated.
3. Press or hold the UP or DOWN button to change the Auto time by 0.5 hour increments, up to 10 hours, then at 1 hour increments up to 24 hours. The control will count down the time remaining until start.
4. The selected time will register in 5 second and the system will automatically revert back to display the previous temperature setting.
5. Turning the unit ON or OFF at any time or adjusting the timer setting to 0.0 will cancel the Auto Start/ Stop timed program.
6. When the malfunction (E1 or E2) occurs, the Auto Start/Stop timed program will also be cancelled.

SLEEP operation

Press this button, the selected temperature will increase (cooling) or decrease (heating) by 1°C/2°F 30 minutes. The temperature will then increase (cooling) or decrease (heating) by another 1°C/2°F after an additional 30 minutes. This new temperature will be maintained for 7 hours before it returns to the originally selected temperature. This ends the Sleep mode and the unit will continue to operate as originally programmed.

NOTE: This feature is unavailable under FAN or DRY mode.

Models 5EAK0 and 5EAK1

ENGLISH

Operation (Continued)

CONTROL PANEL OF THE AIR CONDITIONER

① MODE select button

Selects the appropriate operating mode. Each time you press the button, a mode is selected in a sequence that goes from AUTO, COOL, DRY, FAN and HEAT (cooling only models without). The mode indicator light illuminates under the different mode settings Fig.10.

② TIMER button

Used to initiate the AUTO ON start time and AUTO OFF stop time program, in conjunction with the \triangle & ∇ buttons.

③ POWER button

Power switch on/off.

④ SLEEP button

Used to initiate the SLEEP operation.

⑤ FAN button

Control the fan speed. Press to select the fan speed in four steps-LOW, MED, HI and AUTO. The fan speed indicator light illuminates under different fan settings except AUTO speed. When select AUTO fan speed, all the fan indicator lights turn dark.

⑥ UP(\triangle) and DOWN(∇) button

Used to adjust (increasing/decreasing) temperature settings(1°C/2°F increments) in a range of 17°C(62°F) to 30°C(88°F) or the TIMER setting in a range of 0~24hrs..

NOTE: The control is capable of displaying temperature in degrees Fahrenheit or degrees Celsius. To convert from one to the other, press and hold the Up and Down buttons at the same time, for 3 seconds.

⑦ LED Display

Shows the set temperature in "°C" or "°F" and the Auto-timer settings.

While on DRY and FAN modes, it shows the room temperature.

Error codes:

- E1- Room temperature sensor error-
Unplug the unit and plug it back in.
If error repeats, call for service.
- E2- Evaporator temperature sensor error-
Unplug the unit and plug it back in.
If error repeats, call for service.
- E4- Display panel communication error-
Unplug the unit and plug it back in.
If error repeats, call for service.

P1- Bottom tray is full - Connect the drain hose and drain the collected water away. If error repeats, call for service.

⑧ ION button(optional)

Press the ION button, the ion generator is energized and will help to remove pollen and impurities from the air, and trap them in the filter. Press it again to stop the function.

⑨ SWING button

(Applicable to the models with auto swing feature only)

When the operation is ON, press the SWING button can stop the louver at the desired angle. The louver swing up to an angle of 6° for each press. Keep pressing the button more than 2 seconds can initiate the auto swing feature.

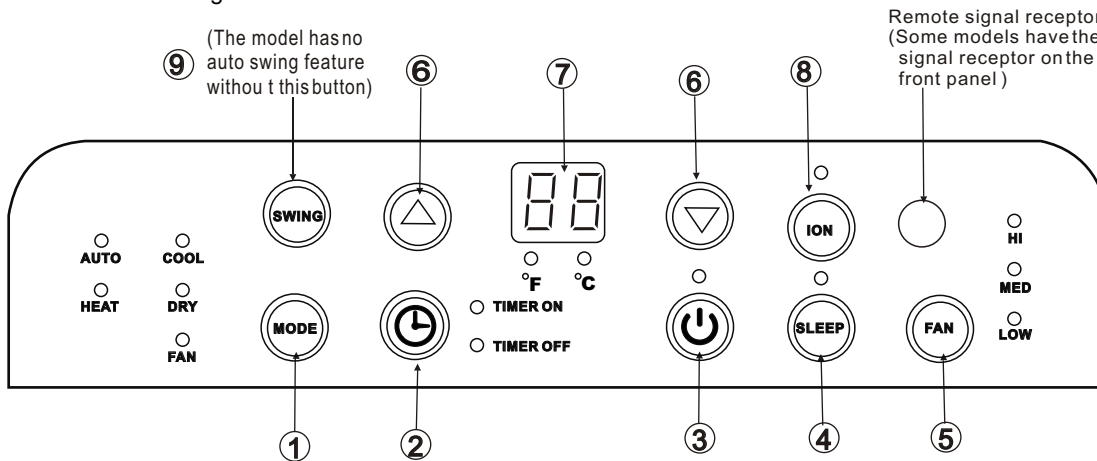

Figure 10 - Control Panel

Dayton® Portable Residential Air Conditioner

ENGLISH

Operation (Continued)

CONTINUOUS DRAINAGE

1. During dehumidifying modes, remove the drain plug from the back of the unit, install the drain connector(5/8" universal female mender) with 3/4" hose(locally purchased). For the models without drain connector, just attach the drain hose to the hole. Place the open end of the hose directly over the drain area in your basement floor.

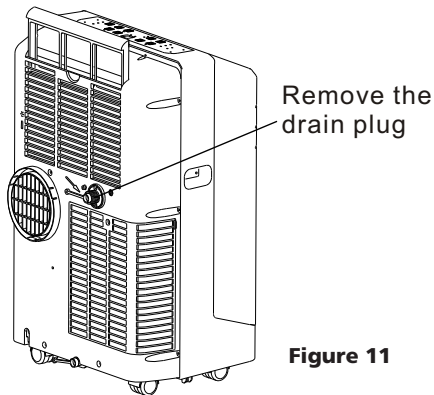

Figure 11

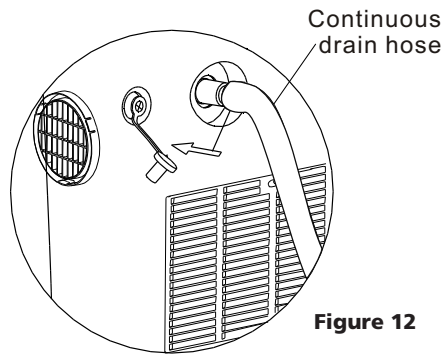

Figure 12

2. When the water level of the bottom tray reaches a predetermined level, the unit beeps 8 times, the digital display area shows "P1". At this time the air conditioning/dehumidification process will immediately stop. However, the fan motor will continue to operate(this is normal). Carefully move the unit to a drain location, remove the bottom drain plug and let the water drain away(Fig.13). Restart the machine until the "P1" symbol disappears. If the error repeats, call for service.

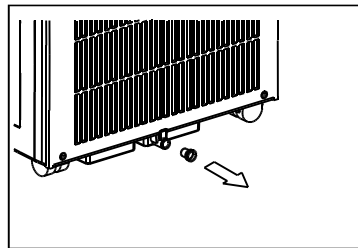

Figure 13

REMOTE CONTROL

1.TEMP UP Button

Push this button to increase the indoor temperature setting in 1°C(2°F) increments to 30°C(88°F).

2.TEMP DOWN Button

Push this button to decrease the indoor temperature setting in 1°C(2°F) increments to 17°C(62°F).

3.MODE Button

Each time the button is pressed, the operation mode is selected in the

sequence of the following:



NOTE: Heat mode is for Cooling & Heating models only.

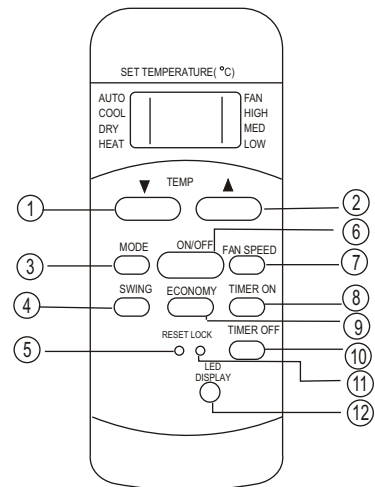

Figure 14 – Remote Control

4.SWING Button(on some models)

Used to stop or start louver movement and set the desired up/down airflow direction.

5.RESET Button

Once the recessed RESET button is pressed, all of the current settings will be cancelled and the controller will return to the initial settings.

6.ON/OFF Button

Operation starts when this button is pressed and stops when the button is pressed again.

7.FAN SPEED Button

Used to select the fan speed in four steps:

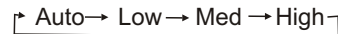

8.TIMER ON Button

Press this button to activate the Auto-on time setting. Each press will increase the time setting in 30 minutes increments, up to 10 hours, then at 1 hour increments up to 24 hours. To cancel the Auto-on

TEMPERATURE CONVERSION CHART

°C	10	11	12	13	14	15	16	17	18	19	20	21	22	23	24	25	26	27	28	29	30	31	32	33
°F	48	50	52	54	56	58	60	62	64	66	68	70	72	74	76	78	80	82	84	86	88	90	92	94

Models 5EAK0 and 5EAK1

Operation (Continued)

time setting, just press the button until the time setting is 0.0.

9.ECONOMY(SLEEP) Button

Select this function during the sleeping time. It can maintain the most comfortable temperature and save energy. This function is available on COOL, HEAT or AUTO mode only .

NOTE: While the unit is running under Energy-saving mode, it would be cancelled if any other buttons are pressed.

10.TIMRT OFF Button

Press this button to activate the Auto-off time setting. Each press will increase the time setting in 30 minutes increments, up to 10 hours, then at 1 hour increments up to 24 hours. To cancel the Auto-off time setting, just press the button until the time setting is 0.0.

11.LOCK Button

Press this recessed button to lock all current settings, and the remote controller will not accept any operation except that of the LOCK. Use the LOCK mode when you want to prevent settings from being changed accidentally. Press the LOCK button again to cancel the LOCK function. A lock symbol will appear on the remote controller display when the lock function is activated.

12.LED Display Button

Press this button to clear the display on the indoor unit, press it again to light the display .

13.FOLLOW ME Button

a. Press this button to initiate FOLLOW ME function.

- b. When the Follow Me function is activated, the remote display is actual temperature at its location. The remote control will send this signal to the air conditioner every 3 minutes interval until press the Follow Me button again.
- c. The Follow Me function is not available under DRY and FAN mode.
- d. Switch the operation mode or turn off the unit will cancel the follow me function automatically.

14.ION Button

When push this button, the ion generator is energized and will help to remove pollen and impurities from the air.

Indicators on LCD

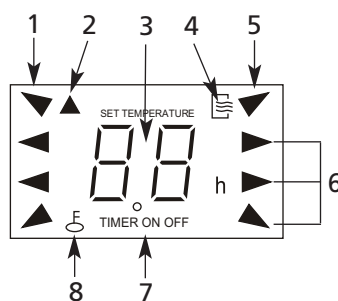

Figure 15

- 1. MODE Display:** Shows the current operation modes—AUTO, COOL, DRY, HEAT and FAN. HEAT only available for heat pump model.
- 2. TRANSMISSION Indicator:** This indicator lights when remote controller transmits signals to indoor unit.
- 3.Temp./Timer display**
The temperature setting (from 17°C(62°F) to 30°C(88°F)) or timer setting (0~24h) will be displayed. If FAN mode is selected, there will be no display.

4.ON/OFF display

This indicator will be displayed when the unit is operating.

5. FAN Display: When the FAN button is pushed, this signal indicator lights.

6.FAN SPEED display

Displays the selected fan speed: AUTO, HIGH, MED and LOW. Nothing displays when the fan speed is selected in AUTO speed. When AUTO or DRY Mode is selected, there will be no signals displayed.

7. TIMER Display: This display area shows the settings of TIMER. That is, if only the starting time of operation is set, it will display the TIMER ON. If only the turning off time of operation is set, it will display the TIMER OFF. If both operations are set, it will show TIMER ON OFF which indicates you have chosen to set both the starting time and off time.

8.LOCK Indicator

LOCK display is displayed when pushing the LOCK button. Push the LOCK button to clear display.

How to use the buttons

Auto operation

Ensure the unit is plugged in and power is available. The OPERATION indicator on the display panel of the indoor unit illuminates.

1. Press the MODE button to select Auto.
2. Press the TEMP button to set the desired temperature. The temperature can be set within a range of 17°C(62°F)~ 30°C(88°F) in 1°C(2°F) increments.
3. Press the ON/OFF button to start the air conditioner.

Dayton® Portable Residential Air Conditioner

Operation (Continued)

NOTE: In the AUTO mode, the air conditioner can logically choose the mode of COOL, FAN, HEAT and DRY by sensing the difference between the actual ambient room temperature and the set temperature on the remote controller.

In the Auto mode, you can not switch the fan speed. It has already been automatically controlled.

If the AUTO mode is not comfortable for you, the desired mode can be selected manually.

Cooling /Heating/Fan operation

Ensure the unit is plugged in and power is available.

1. Press the MODE button to select COOL, HEAT,(cooling & heating models only) or FAN mode.
2. Press the TEMP button to set the desired temperature. The temperature can be set within a range of 17°C(62°F) ~ 30°C in 1°C(2°F) increments.
3. Press the FAN SPEED button to select the fan speed in four steps- Auto, Low, Med,or High.
4. Press the ON/OFF button to start the air conditioner.

NOTE:In the FAN mode, the setting temperature is not displayed in the remote controller and you are not able to control the room temperature either. In this case, only step 1, 3 and 4 may be performed.

Dehumidifying operation

Ensure the unit is plugged in and power is available. The OPERATION indicator on the display panel of the indoor unit illuminates.

1. Press the MODE button to select DRY mode.

2. Press the TEMP button to set the desired temperature. The temperature can be set within a range of 17°C(62°F)~30°C in 1°C(2°F)increments.
3. Press the ON/OFF button to start the air conditioner.

NOTE:In the Dehumidifying mode, you can not switch the fan speed. It has already been automatically controlled.

Swing operation(on some models)

Use the SWING button to adjust the Up/Down airflow direction.

1. When press the button once and quickly, the air flow direction setting feature of the louver is activated. The moving angle of the louver is 6° for each press. Keep pressing the button to move the louver to the desired position.
2. If keep pressing the SWING button without releasing for 2 more seconds, the auto swing feature of the louver is activated. The horizontal louver would swing up/down automatically. Press it again to stop.

NOTE: When the louver swing or move to a position which would affect the cooling and heating effect of the air conditioner, it would automatically change the swing/moving direction.

Timer operation

TIMER ON button can set the auto-on time of the unit. TIMER OFF button can set the auto-off time of the unit.

1. To set the starting time:
 - a. Push the TIMER ON button, then the remote controller shows TIMER ON, the last set time for the starting operation and the signal "h" will be shown on the DIGITAL DISPLAY area. You are now ready

to reset the time to START the operation.

- b. Push the TIMER ON button again to set desired unit start time.
- c. After setting the TIMER ON ,there will be a one-half second delay before the remote controller transmits the signal to the air conditioner. Then, after approximately another 2 seconds, the signal "h" disappears and the set temperature will reappear on the digital display.

2. To set the stopping time:

- a. Push the TIMER OFF button and the remote controller will show TIMER OFF, the last set time for the stopping operation and the signal "h" will be shown on the DIGITAL DISPLAY area. You are now ready to reset the time of the STOP operation.
- b. Push the TIMER OFF button again to set the time you want to stop the operation.
- c. After setting the TIMER OFF, there will be a one-half second delay before the remote controller transmits the signal to the air conditioner. Then, after approximately another 2 seconds, the signal "h" disappears and the set temperature will reappear on the digital display.

ECONOMY(SLEEP) operation

When you press the ECONOMY button, the economic running function will be activated,the set temperature will increase(cooling) or decrease(heating) by 1°C(2°F) over the next 30 minutes and by another 1°C(2°F) after an

Models 5EAK0 and 5EAK1

Operation (Continued)

additional 30 minutes. This new temperature will be maintained for 7 hours before it returns to the originally selected temperature. (NOTE: On some models, the set temperature will increase (cooling) or decrease (heating) by 1°C (2°F) per hour for 2 hours. This new temperature will be maintained for 5 hours, then the unit is off.)

NOTE: The ECONOMY/SLEEP function is only available under Cooling, Heating and AUTO operation.

▲ WARNING *Be sure there are no barriers between the remote controller and the receiver of indoor unit otherwise the air conditioner will not work.*

Keep the Remote Controller away from all liquids.

Protect the Remote Controller from high temperatures and exposure to radiation.

Keep the indoor receiver out of direct sunlight or the Air Conditioner may malfunction.

Keep controller away from EMI (Electro-Magnetic Interference) supplied by other household appliances.

Maintenance

▲ WARNING *Be sure to unplug unit before cleaning or servicing.*

DO NOT use gasoline, thinner or other chemicals to clean the unit.

NEVER wash the unit directly under a tap or hose.

1. Air filter

- a. Clean the air filter at least once every two weeks to prevent inferior fan operation because of dust.

b. Removal

This unit has two filter. Grasp the upper filter tab (Fig.16), pull the filter out "then up". Remove the lower filter by loosening the screw, taking down the air inlet grille, then removing the air filter as shown in Fig.17 & 18.

c. Cleaning

Wash the air filter by immersing it gently in warm water (about 40°C/104°F) with a neutral detergent. Rinse the filter and dry it in a shady place.

d. Mounting

Insert the upper air filter from upward after cleaning, attach the lower air filter on the air inlet grille, then install the grille by using the screw.

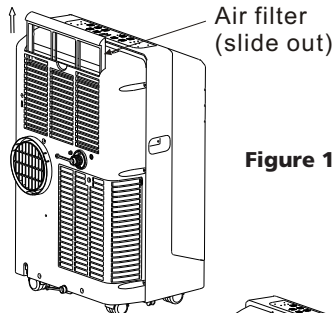

Figure 16

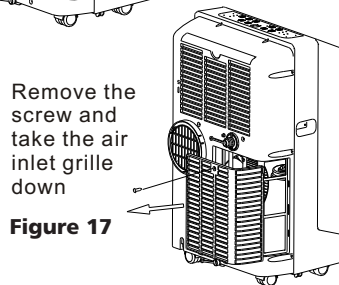

Figure 17

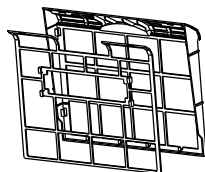

Figure 18

2. Unit enclosure

Use a lint-free cloth soaked with neutral detergent to clean the unit enclosure. Finished by a dry clean cloth.

3. Unit idle for a long time

- a. Remove the rubber plug at the back of the unit and attach a hose to drain outlet. Place the open end of the hose directly over the drain area in your basement floor.
- b. Remove the plug from the bottom drain outlet, all the water in the bottom tray would drain out.
- c. Keep the appliance running on FAN mode for half a day in a warm room to dry the appliance inside and prevent mold forming.
- d. Stop the appliance and unplug it, wrapped the cord and bundle it with the tape (Fig.19). Remove the batteries from the remote controller.
- e. Clean the air filter and reinstall it.
- f. Unscrew the exhaust hose to the right or left and pull out for uninstallation, keep it safety, and cover the window (wall) hole with the adaptor cap.

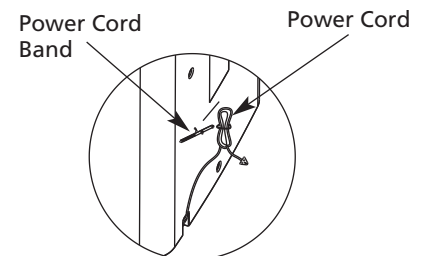

Figure 19

ENGLISH

Dayton® Portable Residential Air Conditioner

Troubleshooting Chart

Symptom	Possible Cause(s)	Corrective Action
Unit does not start when pressing power button	<ol style="list-style-type: none"> 1. P1 appears in the display window 2. Room temperature is lower than the set temperature (Cooling mode) 	<ol style="list-style-type: none"> 1. Drain the water in the bottom tray. 2. Reset the temperature
Not cool enough	<ol style="list-style-type: none"> 1. The windows or doors in the room are not closed 2. There are heat sources inside the room 3. Exhaust air duct is not connected or blocked 4. Temperature setting is too high 5. Air filter is blocked by dust 	<ol style="list-style-type: none"> 1. Make sure all the windows and doors are closed 2. Remove the heat sources if possible 3. Connect the duct and make sure it can function properly 4. Decrease the set temperature 5. Clean the air filter
Power shuts off at heating mode	The automatic over heat protection functioned. When the temperature at the air outlet exceeds 70°C/158°F, the device will stop	Switch on again after the unit has cooled down
Noisy or vibrating	The ground is not level or not flat enough	Place the unit on flat, level ground if possible
Gurgling sound	The sound comes from the flowing of the refrigerant inside the air-conditioner	It is normal

For Repair Parts, call 1-800-323-0620

24 hours a day – 365 days a year

Please provide following information:

- Model number
- Serial number (if any)
- Part description and number as shown in parts list

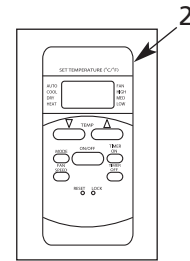

E
N
G
L
I
S
H

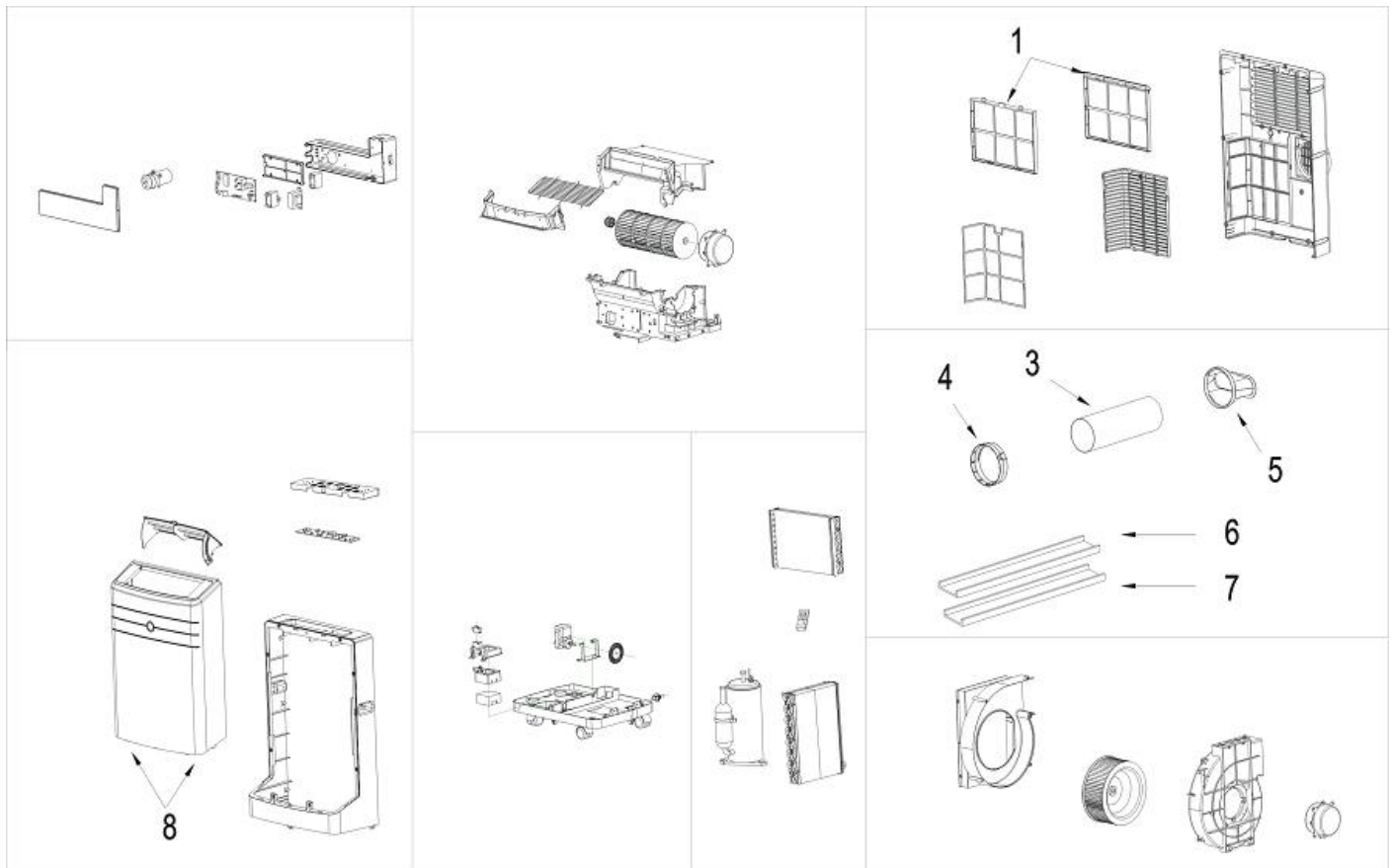

Figure 20 – Repair Parts Illustration for Portable Residential Air Conditioner

Models 5EAK0 and 5EAK1

Repair Parts List for Portable Residential Air Conditioner

Ref. No.	Description	Part No.	Qty.	Ref. No.	Description	Part No.	Qty.
1.	Inlet Air Filter and Guard Set	HV201125080115G	1	7.	Window Slider 2	HV201125090002G	1
2.	Remote Control	HV2033 * * * * * G	1	8.	Caster Set	HV202725000002G	4
3.	Warm Air Exhaust Duct	HV201125000013G	1				
4.	Exhaust Duct Flange	HV201125090064G	1	Δ	Drain Hose Kit	HV201125080131G	1
5.	Window Slider Adapter Flange	HV201125090063G	1	Δ	Upper Plug	HV202725490003G	1
6.	Window Slider 1	HV201125090001G	1				

(Δ) Not shown.

E
N
G
L
I
S
H

Dayton® Portable Residential Air Conditioner

LIMITED WARRANTY

DAYTON ONE-YEAR LIMITED WARRANTY. DAYTON® PORTABLE RESIDENTIAL AIR CONDITIONER, MODELS COVERED IN THIS MANUAL, ARE WARRANTED BY DAYTON ELECTRIC MFG. CO. (DAYTON) TO THE ORIGINAL USER AGAINST DEFECTS IN WORKMANSHIP OR MATERIALS UNDER NORMAL USE FOR ONE YEAR AFTER DATE OF PURCHASE. ANY PART WHICH IS DETERMINED TO BE DEFECTIVE IN MATERIAL OR WORKMANSHIP AND RETURNED TO AN AUTHORIZED SERVICE LOCATION, AS DAYTON DESIGNATES, SHIPPING COSTS PREPAID, WILL BE, AS THE EXCLUSIVE REMEDY, REPAIRED OR REPLACED AT DAYTON'S OPTION. FOR LIMITED WARRANTY CLAIM PROCEDURES, SEE "PROMPT DISPOSITION" BELOW. THIS LIMITED WARRANTY GIVES PURCHASERS SPECIFIC LEGAL RIGHTS WHICH VARY FROM JURISDICTION TO JURISDICTION.

LIMITATION OF LIABILITY. TO THE EXTENT ALLOWABLE UNDER APPLICABLE LAW, DAYTON'S LIABILITY FOR CONSEQUENTIAL AND INCIDENTAL DAMAGES IS EXPRESSLY DISCLAIMED. DAYTON'S LIABILITY IN ALL EVENTS IS LIMITED TO AND SHALL NOT EXCEED THE PURCHASE PRICE PAID.

WARRANTY DISCLAIMER. A DILIGENT EFFORT HAS BEEN MADE TO PROVIDE PRODUCT INFORMATION AND ILLUSTRATE THE PRODUCTS IN THIS LITERATURE ACCURATELY; HOWEVER, SUCH INFORMATION AND ILLUSTRATIONS ARE FOR THE SOLE PURPOSE OF IDENTIFICATION, AND DO NOT EXPRESS OR IMPLY A WARRANTY THAT THE PRODUCTS ARE MERCHANTABLE, OR FIT FOR A PARTICULAR PURPOSE, OR THAT THE PRODUCTS WILL NECESSARILY CONFORM TO THE ILLUSTRATIONS OR DESCRIPTIONS. EXCEPT AS PROVIDED BELOW, NO WARRANTY OR AFFIRMATION OF FACT, EXPRESSED OR IMPLIED, OTHER THAN AS STATED IN THE "LIMITED WARRANTY" ABOVE IS MADE OR AUTHORIZED BY DAYTON.

Technical Advice and Recommendations, Disclaimer. Notwithstanding any past practice or dealings or trade custom, sales shall not include the furnishing of technical advice or assistance or system design. Dayton assumes no obligations or liability on account of any unauthorized recommendations, opinions or advice as to the choice, installation or use of products.

Product Suitability. Many jurisdictions have codes and regulations governing sales, construction, installation, and/or use of products for certain purposes, which may vary from those in neighboring areas. While attempts are made to assure that Dayton products comply with such codes, Dayton cannot guarantee compliance, and cannot be responsible for how the product is installed or used. Before purchase and use of a product, review the product applications, and all applicable national and local codes and regulations, and be sure that the product, installation, and use will comply with them.

Certain aspects of disclaimers are not applicable to consumer products; e.g., (a) some jurisdictions do not allow the exclusion or limitation of incidental or consequential damages, so the above limitation or exclusion may not apply to you; (b) also, some jurisdictions do not allow a limitation on how long an implied warranty lasts, consequently the above limitation may not apply to you; and (c) by law, during the period of this Limited Warranty, any implied warranties of implied merchantability or fitness for a particular purpose applicable to consumer products purchased by consumers, may not be excluded or otherwise disclaimed.

Prompt Disposition. A good faith effort will be made for prompt correction or other adjustment with respect to any product which proves to be defective within limited warranty. For any product believed to be defective within limited warranty, first write or call dealer from whom the product was purchased. Dealer will give additional directions. If unable to resolve satisfactorily, write to Dayton at address below, giving dealer's name, address, date, and number of dealer's invoice, and describing the nature of the defect. Title and risk of loss pass to buyer on delivery to common carrier. If product was damaged in transit to you, file claim with carrier.

Manufactured for Dayton Electric Mfg. Co., 5959 W. Howard St., Niles, Illinois 60714-4014 U.S.A.