

Installation Instructions



Solar Controller Kit (Part Number 299121)

SOLAR CONTROLLER KIT

For installation with a solar storage tank with a raised solar hot water inlet

Your solar water heater is designed for the solar collectors to be roof mounted and the solar storage tank to be installed at ground or floor level. This solar controller kit is designed to be mounted on the side of the solar storage tank incorporating a raised solar hot water inlet. The solar control unit governs the operation of the solar water heater. For full details on the installation of the solar storage tank, the cold water plumbing supply details and electrical connections to the tank, refer to the Owners Guide and Installation Instructions supplied with the solar storage tank. The Owners Guide also contains consumer information on the operation of the solar water heater system.

PATENTS

This water heater may be protected by one or more patents or registered designs.

*This solar controller kit must be installed and serviced by an authorised person.
Please leave this guide with the householder.*

INSTALLATION – SOLAR CONTROL UNIT

The solar control unit is designed to be mounted on the side of the solar storage tank, with its location above and offset from the solar cold water outlet. The solar control unit, supplied with a 1.8 metre power cord, requires a 240 V 50 Hz general purpose outlet (GPO) located within 1.2 metres of its installation. The GPO must have a continuous power supply originating from a circuit other than the water heater circuit. The GPO is required to be weatherproof if installed outdoors (refer to “Connections – Electrical” on page 8).

Part No	Kit Components and Description - Controller Kit	299121
126554	Installation instructions solar controller kit	1
052104	Control unit solar pumped assembly	1
220342	Valve assembly air bleed and check consisting of: 1 x 088058 fitting tee brass ½” screwed Rye 4203 1 x 088071 solar non return valve RMC ½” x ¾” SNR502 1 x 088069 fitting adaptor brass 1” F x ½” M 1 x 220340 air bleed ball valve 1 x 080123 washer 30 OD x 20 ID x 2 Salmson	1
088064	Sensor tee / nipple assembly solar pumped consisting of: 1 x 088061 tee 3 way / cold sensor 1 x 088062 sensor nipple – solar pumped 1 x 087026 O ring 5/16” ID x 1/16” BS011 silicone	1
223603	Pipe preformed tube ½” x 240 mm long	1
080031	Screws No 8 x 13 mm	4
088063	Fitting union male ½” x ½” Rye 4910	3
088039	Fitting nipple brass ¾” x ½”	1
080079	Plug ½” BSP brass	1
	Cable tie black 150 mm x 3 mm	3
	Insulation pipe 12 mm ID x 280 mm long	1
	Insulation pipe 35 mm ID x 150 mm long	1
	Insulation pipe 35 mm ID x 50 mm long	1

Notes:

- Care must be taken when mounting the solar control unit to the side of the solar storage tank. Damage to the cylinder as a result of mounting the solar control unit to the jacket will void the warranty (refer to “Saddling - Pipe Work” on page 7).
- Use thread sealing tape or an approved thread sealant on all fittings.

INSTALLATION – SOLAR CONTROL UNIT

SOLAR STORAGE TANK WITH RAISED SOLAR HOT INLET

Numbers in parentheses refer to items on diagram on page 5.

To connect the solar cold pipe and mount the solar control unit on a solar storage tank with a raised solar hot inlet (and raised heating unit):

- Assemble a ½" x ½" hex nipple (1) into the branch outlet of the 4 way tee (2) (ensure the compression end of the nipple is exposed) and the ½" x ¾" hex nipple (3) in the end of the 4 way tee, so that when the assembly is fitted to the cold water inlet of the solar storage tank, the compression nipple (1) is orientated vertically upwards and the cold sensor housing is orientated to the rear of the solar storage tank.
- Fit the assembly to the solar cold water outlet of the solar storage tank.
- Fit the ½" plug (15) into the end of the 4 way tee.
- Connect the DN15 preformed pipe (4) to the branch tee connection, using the compression nut (5) and olive (6) provided, ensuring the longer straight end is orientated upwards.
- Insulate the preformed pipe (4) with the 280 mm long x 12 mm diam insulation (12) provided, ensuring the insulation is pushed down the full length of the pipe.
- Fit a ½" x ½" hex nipple (1) to the **outlet** of the circulator (7) mounted in the solar control unit (8) (ensure the compression end of the nipple is exposed).
- Locate the solar control unit (8) by connecting the DN15 preformed pipe (4) to the nipple on the **inlet** of the circulator (7) using the compression nut (5) and olive (6) provided.
- Secure the solar control unit (8) to the solar storage tank using the four screws (9) provided.
- Connect the solar cold pipe (to the collector) to the nipple (1) on the outlet side of the circulator (7) using the compression nut (5) and olive (6) provided.
- Insert the cold sensor probe (10) into the cold sensor housing on the 4 way tee (2), ensuring the 'O' ring is in position on the probe. Lock it into position with the locking washer and clip provided.
- Connect the hot sensor lead (from the solar collector installation) to the hot sensor cable connector at the underside of the solar control unit (8).

INSTALLATION – SOLAR CONTROL UNIT

To connect the solar hot pipe to the solar storage tank:

- Insulate the solar non return valve of the air bleed valve and solar non return valve assembly (11) with the 50 mm long x 35 mm diam insulation (13) provided.
- Fit the air bleed valve and solar non return valve assembly (11) to the solar hot water inlet of the solar storage tank. Ensure the bleed valve outlet is pointing vertically downwards.
- Connect a DN15 copper drain line to the bleed valve to carry the discharge clear of the water heater and solar control unit (refer to “Bleed Valve Drain” page 7), using the compression nut and olive provided.
- Fit a ½” x ½” hex nipple (1) to the exposed end (inlet) of the air bleed valve and solar non return valve assembly (11) (ensure the compression end of the nipple is exposed).
- Connect the solar hot pipe (from the collector) to the nipple (1) on the air bleed valve and solar non return valve assembly (11) using the compression nut (5) and olive (6) provided.
- Insulate the tee and bleed valve, from the solar hot pipe to the drain line of the bleed valve, with the 150 mm long x 35 mm diam insulation (13) and secure with the cable ties (14) provided.
- Insulate the drain line from the bleed valve with closed cell polymer insulation or similar (minimum thickness 13 mm). The insulation must be weatherproof and UV resistant if exposed.

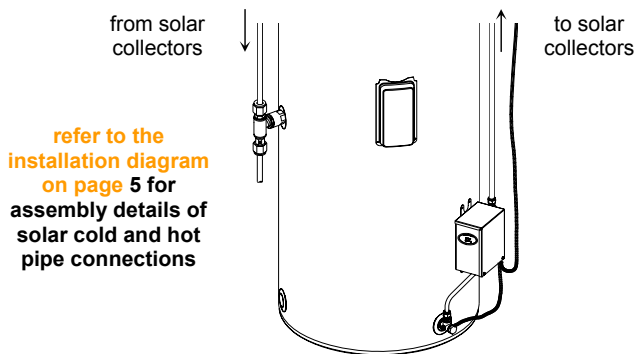

Solar Storage Tank with Solar Control Unit

INSTALLATION – SOLAR CONTROL UNIT

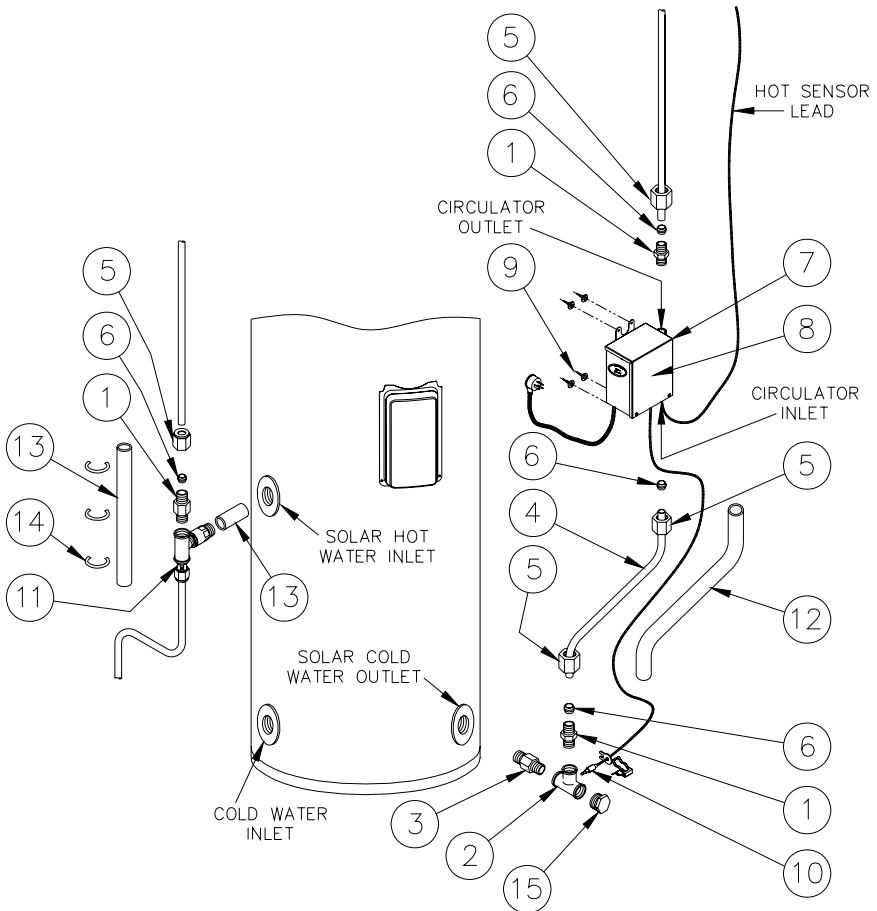

SUPPLIED IN SOLAR CONTROL UNIT KIT (299121)

- | | |
|-------------------------------------------------|-------------------------------------------------------------------|
| 1. Hex nipple $\frac{1}{2}$ " X $\frac{1}{2}$ " | 10. Cold sensor probe |
| 2. 4 way tee | 11. Air bleed valve and non return valve assembly |
| 3. Hex nipple $\frac{1}{2}$ " x $\frac{3}{4}$ " | 12. Insulation 280 mm long x 12 mm diam |
| 4. Preformed pipe DN15 | 13. Insulation 150 mm long x 35 mm diam & 50 mm long x 35 mm diam |
| 5. Compression nut | 14. Cable tie |
| 6. Olive | 15. Plug $\frac{1}{2}$ " |
| 7. Circulator | |
| 8. Solar control unit | |
| 9. Screws | |

CONNECTIONS – PLUMBING

CONNECTION SIZES

- Hot water connection: RP $\frac{3}{4}$ /20.
- Cold water connection: RP $\frac{3}{4}$ /20.
- Solar hot (from collector) connection: DN15 compression fitting. (solar hot inlet to tank RP $\frac{3}{4}$ /20)
- Solar cold (to collector) connection: DN15 compression fitting. (solar cold outlet from tank: RP $\frac{3}{4}$ /20)
- Relief valve connection: RP $\frac{1}{2}$ /15.
- Bleed valve connection: G1.0B.

All plumbing work must be carried out by a qualified person and in accordance with the National Plumbing Standard AS/NZS 3500.4 and local authority requirements.

WATER INLET AND OUTLET

All pipe work must be cleared of foreign matter before connection and purged before attempting to operate the water heater. All olive compression fittings must use brass or copper olives. Use thread sealing tape or approved thread sealant on all fittings.

Refer to the Owners Guide and Installation Instructions supplied with the solar storage tank for the plumbing arrangement to be used for connecting the cold water supply line to the solar water heater system. The plumbing arrangements for the solar cold and solar hot pipes are shown on page 5.

A disconnection union must always be provided at the cold water inlet, solar cold water outlet, solar hot water inlet and hot water outlet on the water heater to allow for disconnection of the water heater.

This water heater has either a plastic dip tube or fitting liner in the inlet and outlet fittings (see diagram). These must be in place for the water heater to function properly. Do not remove or damage them by using heat nearby. They will be pushed into the correct position as the fitting is screwed in.

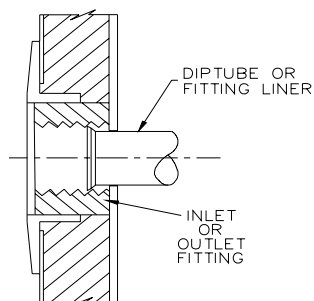

CONNECTIONS – PLUMBING

BLEED VALVE DRAIN

A copper drain line must be fitted to the bleed valve to carry the discharge clear of the water heater and solar control unit. Connect the drain line to the bleed valve using a disconnection union. The pipe work from the bleed valve to the drain should be as short as possible and fall all the way from the valve with no restrictions. It should have no more than three right angle bends in it. Use DN15 pipe.

The outlet of the drain line must be in such a position that flow out of the pipe can be easily seen (refer AS/NZS 3500.4) - but arranged so water discharge will not cause injury, damage, nuisance or splashing. The water discharged may be of a high temperature under certain conditions. The drain line must be fully insulated with closed cell polymer insulation or similar (minimum thickness 13 mm). The insulation must be weatherproof and UV resistant if exposed.

SADDLING - PIPE WORK

To prevent damage to the cylinder when attaching pipe clips or saddles to the water heater jacket, we recommend the use of self-drilling screws with a maximum length of 13 mm. Should pre drilling be required extreme caution must be observed when penetrating the jacket of the water heater.

Note: Damage to the cylinder as a result of saddling to the jacket will void the warranty.

CONNECTIONS – ELECTRICAL

The power supply to the water heater must not be switched on until the water heater is filled with water and a satisfactory megger reading is obtained.

All electrical work and permanent wiring must be carried out by a qualified person and in accordance with the Wiring Rules AS/NZS 3000 and local authority requirements.

The solar control unit, supplied with a 1.8 metre power cord, requires a 240 V 50 Hz general purpose outlet (GPO) to be located within 1.2 metres of the installation. The GPO must have a continuous power supply originating from a circuit other than the water heater circuit. The GPO is required to be weatherproof if installed outdoors.

If the power supply cord or plug is damaged, it must be replaced by an authorised person in order to avoid a hazard. The power supply cord and plug must be replaced with a genuine replacement part available from Rheem, Solahart or Edwards.

SOLAR CONTROLLER AND SOLAR MONITOR

SOLAR MONITOR

A solar monitor is located on the side of the solar control unit and houses a green and a red LED.

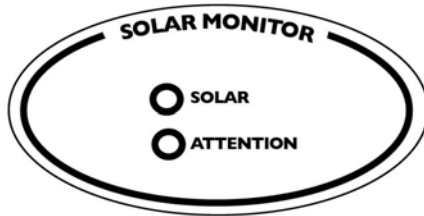

The green LED, marked “Solar”, indicates the current operational mode of the solar water heater and the red LED, marked “Attention”, indicates a fault mode.

The green LED will emit either a constant glow or a series of flashes, with a 2 second interval between each series.

The red LED will emit a series of flashes, with a 2 second interval between each series, only if there is a particular fault condition with the system.

SOLAR CONTROLLER AND SOLAR MONITOR

COMMISSIONING

Refer to the installation instructions supplied with the solar storage tank for the complete commissioning procedure.

When the electrical supply is switched on to the solar control unit at start up:

- If there is no solar gain, the circulator will not activate and the green LED will emit a slow pulse.

The slow pulse indicates the circulator is not activated and the power to the solar control unit has been on for less than 48 hours.

- If there is solar gain, the circulator activates and the green LED will emit a series of three (3) flashes.

The three (3) flashes indicate the circulator is operating and power to the solar control unit has been on for less than 48 hours.

- The circulator will operate at full speed for approximately fifteen (15) seconds. If the red LED is emitting a rapid pulse, the circulator may operate at full speed for up to ten (10) minutes.

After fifteen (15) seconds or after the red LED has extinguished, the solar controller will commence to pulse the circulator to control the flow rate through the collector circuit and achieve a constant temperature rise across the collector(s). It is normal operation for the circulator to experience a pulsing effect.

- The red LED may emit a rapid pulse for a short period.

This indicates a temperature difference between the hot sensor and cold sensor of greater than 40°C and does not represent a fault code. This is the result of a build-up of heat and increase in water temperature in the collector prior to the switching on of the electrical supply to the solar control unit.

The rapid pulsing of the red LED will cease as the water circulates and the heat is dissipated. This should be within four (4) to five (5) minutes of start up, but may take up to ten (10) minutes.

If the red LED does continue to emit a rapid pulse for longer than ten (10) minutes, this may indicate water is not circulating through the collectors and solar circuit:

- switch off the electrical supply at the power outlet to the solar control unit
- repeat the procedure to bleed the solar collectors
- switch on the electrical supply at the power outlet to the solar control unit

SOLAR CONTROLLER AND SOLAR MONITOR

DIAGNOSTIC FEATURES OF THE SOLAR CONTROLLER

The operational modes are:

Flashes	Operational Modes
solid green (remains on)	Standby mode
green slow pulse	Standby mode (power on for less than 48 hours)
green rapid pulse	Circulating water through collectors
3 x green	Circulating water through collectors (power on for less than 48 hours)
no green (remains off)	Power outage or call for service

Flashes	Fault Modes
red rapid pulse	Temperature rise across collector greater than 40°C (circulator at full speed)
3 x red	Hot sensor in collector – short circuit
4 x red	Hot sensor in collector – open circuit
5 x red	Cold sensor –short circuit
6 x red	Cold sensor – open circuit

If the power supply to the solar control unit is on and the green LED is off or the red LED is flashing, this indicates there may be a fault with the water heater. The red LED may emit up to six flashes in each series of flashes.

Note: During periods of high solar radiation and if the circulator activates after having been off, such as during start up, it is possible the red LED may emit a rapid pulse for a period of up to ten (10) minutes. This does not indicate a fault. Refer to “**Commissioning**” on page 10 for the possible green and red LED flashing sequence during start up procedure.

If the red LED continues to emit a rapid pulse for longer than ten (10) minutes, or emits a series of flashes, then count the number of flashes and phone your nearest Service Department or Accredited Service Agent to arrange for an inspection.

Your solar water heater and its components are covered by a comprehensive warranty. For full warranty details, refer to the Owners Guide and Installation Instructions supplied with the solar storage tank.

RHEEM AUSTRALIA PTY LTD
A.B.N. 21 098 823 511
www.rheem.com.au

FOR SERVICE TELEPHONE
131 031 AUSTRALIA
0800 657 335 NEW ZEALAND
or refer local Yellow Pages

Note: Every care has been taken to ensure accuracy in preparation of this publication. No liability can be accepted for any consequences, which may arise as a result of its application.

Revision Date: 2007 November

126554C