

ORDERING REPLACEMENT PARTS

To order replacement parts, contact the ICON Health & Fitness, Ltd. office, or write:

ICON Health & Fitness, Ltd.
Unit 4
Revie Road Industrial Estate
Revie Road, Beeston
Leeds, LS11 8JG
UK

Tel:

08457 089 009

Fax: 0 (044) 113 387 7125

When ordering parts, please be prepared to give the following information:

- The MODEL NUMBER of the product (PETL61021)
- The NAME of the product (PROFORM® 10.5 QM treadmill)
- The SERIAL NUMBER of the product (see the front cover of this manual)
- The KEY NUMBER and the DESCRIPTION of the part(s) (see the PART LIST and the EXPLODED DRAWING attached in the centre of this manual)



Model No. PETL61021

Serial No. _____

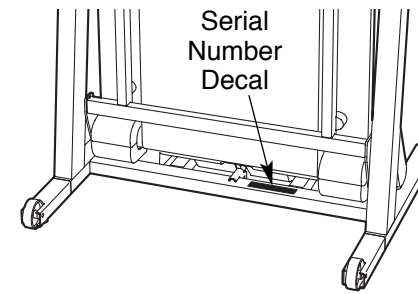

QUESTIONS?

As a manufacturer, we are committed to providing complete customer satisfaction. If you have questions, or if there are missing or damaged parts, please call:

08457 089 009

Or write:
ICON Health & Fitness, Ltd.
Customer Service Department
Unit 4
Revie Road Industrial Estate
Revie Road, Beeston
Leeds, LS118JG
UK

email: csuk@iconeurope.com

⚠ CAUTION

Read all precautions and instructions in this manual before using this equipment. Save this manual for future reference.

USER'S MANUAL

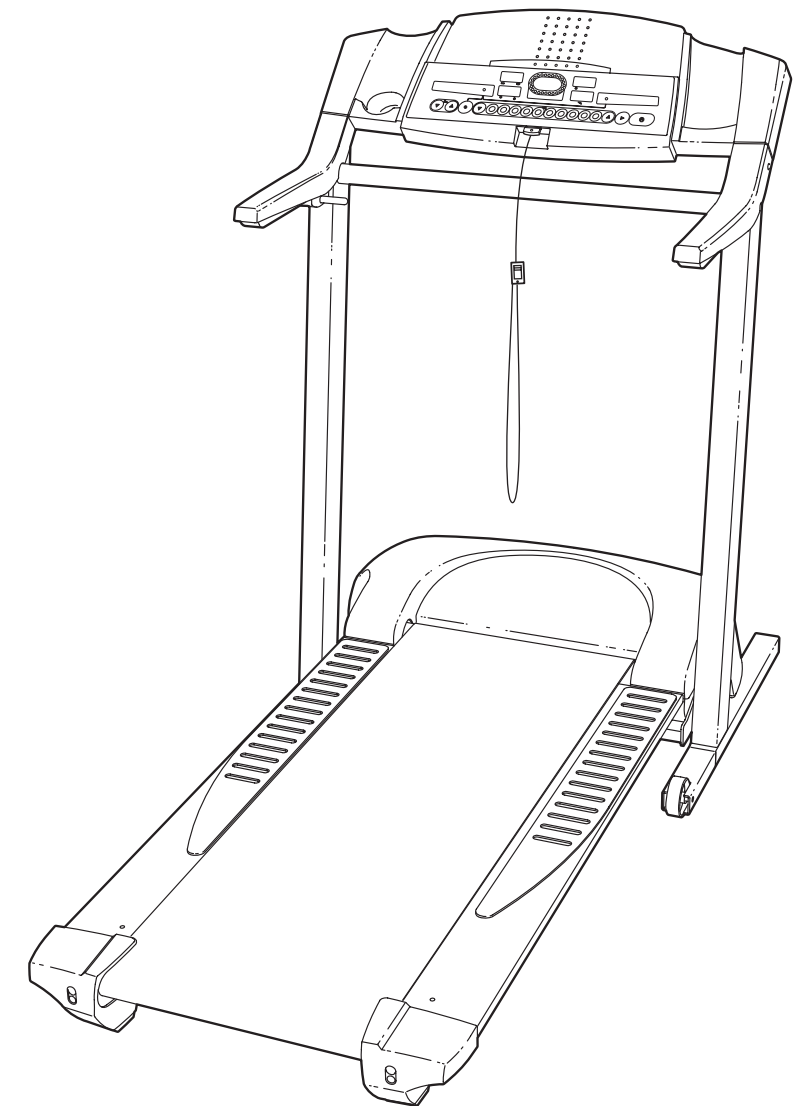

Visit our website at

www.iconeurope.com



TABLE OF CONTENTS

IMPORTANT PRECAUTIONS	.3
BEFORE YOU BEGIN	.5
ASSEMBLY	.6
HOW TO USE THE CHEST PULSE SENSOR	.8
OPERATION AND ADJUSTMENT	.9
HOW TO FOLD AND MOVE THE TREADMILL	.19
TROUBLESHOOTING	.20
CONDITIONING GUIDELINES	.23
ORDERING REPLACEMENT PARTS	Back Cover

Note: An EXPLODED DRAWING and a PART LIST are attached in the centre of this manual.

CONDITIONING GUIDELINES

⚠ WARNING: Before beginning this or any exercise program, consult your physician. This is especially important for individuals over the age of 35 or individuals with pre-existing health problems.

The pulse sensor is not a medical device. Various factors, including your movement, may affect the accuracy of heart rate readings. The sensor is intended only as an exercise aid in determining heart rate trends in general.

The following guidelines will help you to plan your exercise program. For more detailed exercise information, obtain a reputable book or consult your physician.

EXERCISE INTENSITY

Whether your goal is to burn fat or to strengthen your cardiovascular system, the key to achieving the desired results is to exercise with the proper intensity. The proper intensity level can be found by using your heart rate as a guide. The chart below shows recommended heart rates for fat burning and aerobic exercise.

AEROBIC	165	155	145	140	130	125	115
MAX FAT BURN	145	138	130	125	118	110	103
FAT BURN	125	120	115	110	105	95	90
Age	20	30	40	50	60	70	80

To find the proper heart rate for you, first find your age near the bottom of the chart (ages are rounded off to the nearest ten years). Next, find the three numbers above your age. The three numbers define your "training zone." The lower two numbers are recommended heart rates for fat burning; the higher number is the recommended heart rate for aerobic exercise.

To measure your heart rate during exercise, use the chest pulse sensor.

Fat Burning

To burn fat effectively, you must exercise at a relatively low intensity level for a sustained period of time. During the first few minutes of exercise, your body uses easily accessible carbohydrate calories for en-

ergy. Only after the first few minutes does your body begin to use stored fat calories for energy. If your goal is to burn fat, adjust the speed and incline of the treadmill until your heart rate is near the lowest number in your training zone.

For maximum fat burning, adjust the speed and incline of the treadmill until your heart rate is near the middle number in your training zone.

Aerobic Exercise

If your goal is to strengthen your cardiovascular system, your exercise must be "aerobic." Aerobic exercise is activity that requires large amounts of oxygen for prolonged periods of time. This increases the demand on the heart to pump blood to the muscles, and on the lungs to oxygenate the blood. For aerobic exercise, adjust the speed and incline of the treadmill until your heart rate is near the highest number in your training zone.

WORKOUT GUIDELINES

Each workout should include the following three parts:

A Warm-up—Start each workout with 5 to 10 minutes of stretching and light exercise. A proper warm-up increases your body temperature, heart rate and circulation in preparation for exercise.

Training Zone Exercise—After warming up, increase the intensity of your exercise until your pulse is in your training zone for 20 to 60 minutes. (During the first few weeks of your exercise program, do not keep your pulse in your training zone for longer than 20 minutes.) Breathe regularly and deeply as you exercise—never hold your breath.

A Cool-down—Finish each workout with 5 to 10 minutes of stretching to cool down. This will increase the flexibility of your muscles and will help prevent post-exercise problems.

EXERCISE FREQUENCY

To maintain or improve your condition, complete three workouts each week, with at least one day of rest between workouts. After a few months, you may complete up to five workouts each week if desired. The key to success is to make exercise a regular and enjoyable part of your everyday life.

PROBLEM: The incline of the treadmill does not change correctly or does not change when iFIT.com CDs and videos are played

SOLUTION: a. With the key inserted in the console, press one of the Incline buttons. **Whilst the incline is changing, remove the key.** After a few seconds, re-insert the key. The treadmill will automatically rise to the maximum incline level and then return to the minimum level. This will recalibrate the incline.

PROBLEM: The heart rate monitor does not function properly

SOLUTION: a. If the heart rate monitor does not function properly, refer to CHEST PULSE SENSOR TROUBLESHOOTING on page 8.

b. If the heart rate monitor still does not function properly, the battery should be changed. To replace the battery, locate the battery cover on the back of the sensor unit. Insert a coin into the slot in the cover and turn the cover counterclockwise to the "open" position. Remove the cover.

Next, remove the old battery from the sensor unit. Insert a new **CR 2032 battery**, making sure that the writing is on top. In addition, make sure that the rubber gasket is in place in the sensor unit. Replace the battery cover and turn it to the closed position.

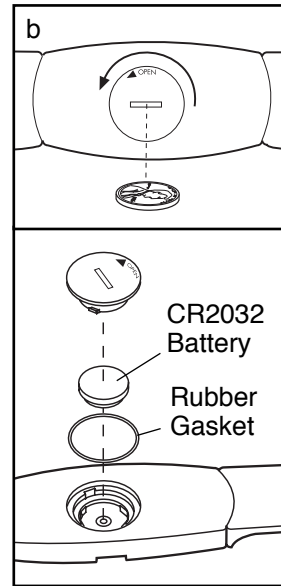

IMPORTANT PRECAUTIONS

WARNING: To reduce the risk of burns, fire, electric shock, or injury to persons, read the following important precautions and information before operating the treadmill.

1. It is the responsibility of the owner to ensure that all users of this treadmill are adequately informed of all warnings and precautions.
2. Use the treadmill only as described.
3. Place the treadmill on a level surface, with 2.5 m (8 ft.) of clearance behind it and 0.5 m (2 ft.) on each side. Do not place the treadmill on a surface that blocks any air openings. To protect the floor or carpet from damage, place a mat under the treadmill.
4. Keep the treadmill indoors, away from moisture and dust. Do not put the treadmill in a garage or covered patio, or near water.
5. Do not operate the treadmill where aerosol products are used or where oxygen is being administered.
6. Keep children under the age of 12 and pets away from the treadmill at all times.
7. The treadmill should be used only by persons weighing 115 kg (250 lbs.) or less.
8. Never allow more than one person on the treadmill at a time.
9. Wear appropriate exercise clothes when using the treadmill. Do not wear loose clothes that could become caught in the treadmill. Athletic support clothes are recommended for both men and women. Always wear athletic shoes. Never use the treadmill with bare feet, wearing only stockings, or in sandals.
10. When connecting the power cord (see page 9), plug the power cord into an earthed circuit. No other appliance should be on the same circuit. When replacing the fuse, an ASTA approved BS1362 type should be fitted to the fuse carrier. A 13 amp fuse should be used.
11. If an extension cord is needed, use only a 3-conductor, 1 mm² (14-gauge) cord that is no longer than 1.5 m (5 ft.).
12. Keep the power cord and the surge suppressor away from heated surfaces.
13. Never move the walking belt whilst the power is turned off. Do not operate the treadmill if the power cord or plug is damaged, or if the treadmill is not working properly. (See **BEFORE YOU BEGIN** on page 5 if the treadmill is not working properly.)
14. Never start the treadmill whilst you are standing on the walking belt. Always hold the handrails whilst using the treadmill.
15. The treadmill is capable of high speeds. Adjust the speed in small increments to avoid sudden jumps in speed.
16. The pulse sensor is not a medical device. Various factors, including the user's movement, may affect the accuracy of heart rate readings. The pulse sensor is intended only as an exercise aid in determining heart rate trends in general.
17. Never leave the treadmill unattended whilst it is running. Always remove the key, unplug the power cord, and move the on/off switch to the off position when the treadmill is not in use. (See the drawing on page 5 for the location of the on/off switch.)
18. Do not attempt to raise, lower, or move the treadmill until it is properly assembled. (See **ASSEMBLY** on page 6, and **HOW TO FOLD AND MOVE THE TREADMILL** on page 19.) You must be able to safely lift 20 kg (45 lbs.) in order to raise, lower, or move the treadmill.
19. Do not change the incline of the treadmill by placing objects under the treadmill.
20. When folding or moving the treadmill, make sure that the storage latch is fully closed.

21. When using iFIT.com CDs and videos, an electronic “chirping” sound will alert you when the speed and/or incline of the treadmill is about to change. Always listen for the “chirp” and be prepared for speed and/or incline changes. In some instances, the speed and/or incline may change before the personal trainer describes the change.

22. When using iFIT.com CDs and videos, you can manually override the speed and incline settings at any time by pressing the speed and incline buttons. However, when the next “chirp” is heard, the speed and/or incline will change to the next settings of the CD or video program.

23. Always remove iFIT.com CDs and videos from your CD player or VCR when you are not using them.

24. Inspect and properly tighten all parts of the treadmill regularly.

25. Never insert or drop any object into any opening.

26. **DANGER:** Always unplug the power cord immediately after use, before cleaning the treadmill, and before performing the maintenance and adjustment procedures described in this manual. Never remove the motor hood unless instructed to do so by an authorised service representative. Servicing other than the procedures in this manual should be performed by an authorised service representative only.

27. This treadmill is intended for in-home use only. Do not use this treadmill in any commercial, rental, or institutional setting.

WARNING: Before beginning this or any exercise program, consult your physician. This is especially important for persons over the age of 35 or persons with pre-existing health problems. Read all instructions before using. ICON assumes no responsibility for personal injury or property damage sustained by or through the use of this product.

SAVE THESE INSTRUCTIONS

The decals shown below have been placed on your treadmill. If a decal is missing, or if it is not legible, please call our Customer Service Department to order a free replacement decal (see the back cover of this manual). Apply the decals in the locations shown.

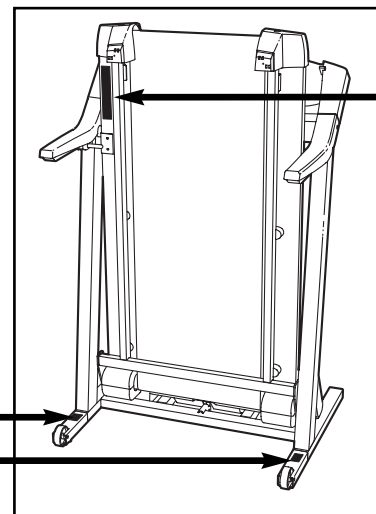

Note: The decal at the right is shown at 50% of actual size.

WARNING:

Protect yourself and others from risk of serious injury. Read the user's manual and:

- Stand only on the side rails when starting or stopping treadmill.
- Change speed in small increments.
- Hold handrails to prevent falling, and always wear the safety clip while operating treadmill.
- Stop if you feel faint, dizzy, or short of breath.
- Fully engage storage latch before treadmill is moved or stored.
- Reduce incline to its lowest level before folding treadmill into storage position.
- Never allow children on or around treadmill.
- Remove key when not in use.
- Keep clothing, fingers, and hair away from moving belt.
- Never try to adjust or fix the belt while it is moving.
- Always wear athletic shoes while operating treadmill.

Locate the Reed Switch (18) and the Magnet (101) on the left side of the Pulley (78). Turn the Pulley until the Magnet is aligned with the Reed Switch. **Make sure that the gap between the Magnet and the Reed Switch is about 3mm (1/8 in.).** If necessary, loosen the 3/4" Screw (24) and move the Reed Switch slightly. Retighten the Screw. Re-attach the hood, and run the treadmill for a few minutes to check for a correct speed reading.

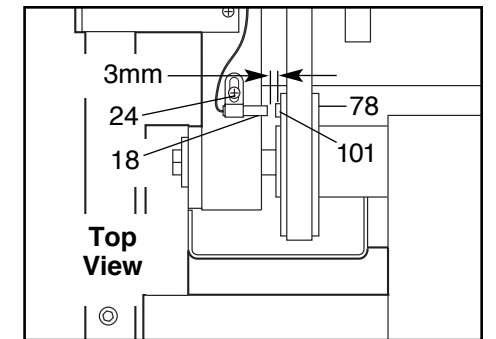

PROBLEM: The walking belt slows when walked on

SOLUTION: a. If an extension cord is needed, use only a 3-conductor, 1 mm² (14-gauge) cord that is no longer than 1.5 m (5 ft.).

b. If the walking belt is overtightened, treadmill performance may decrease and the walking belt may become damaged. Remove the key and **UNPLUG THE POWER CORD**. Using the allen wrench, turn both rear roller adjustment bolts counterclockwise, 1/4 of a turn. When the walking belt is properly tightened, you should be able to lift each side of the walking belt 7 to 10 cm (3 to 4 in.) off the walking platform. Be careful to keep the walking belt centred. Plug in the power cord, insert the key and run the treadmill for a few minutes. Repeat until the walking belt is properly tightened.

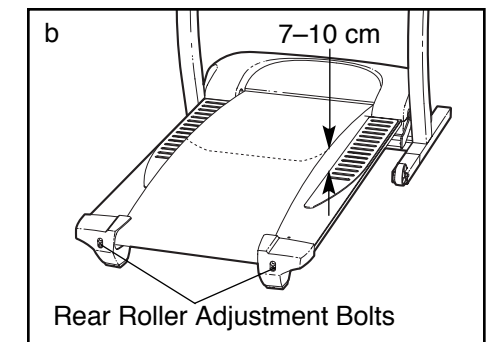

c. If the walking belt still slows when walked on, call our Customer Service Department, toll-free.

PROBLEM: The walking belt is off-centre or slips when walked on

SOLUTION: a. If the walking belt is off-centre, first remove the key and **UNPLUG THE POWER CORD**. If the walking belt has shifted to the left, use the allen wrench to turn the left rear roller bolt clockwise 1/2 of a turn; if the walking belt has shifted to the right, turn the bolt counterclockwise 1/2 of a turn. Be careful not to overtighten the walking belt. Plug in the power cord, insert the key and run the treadmill for a few minutes. Repeat until the walking belt is centred.

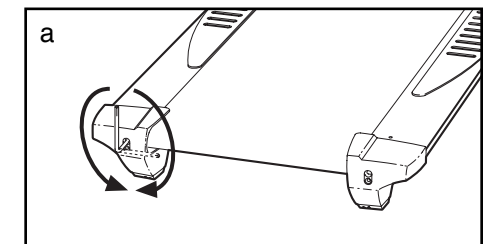

b. If the walking belt slips when walked on, first remove the key and **UNPLUG THE POWER CORD**. Using the allen wrench, turn both rear roller bolts clockwise, 1/4 of a turn. When the walking belt is correctly tightened, you should be able to lift each side of the walking belt 7 to 10 cm (3 to 4 in.) off the walking platform. Be careful to keep the walking belt centred. Plug in the power cord, insert the key and carefully walk on the treadmill for a few minutes. Repeat until the walking belt is properly tightened.

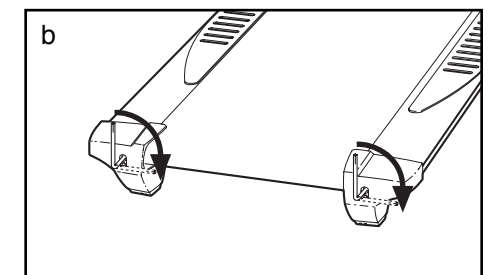

TROUBLESHOOTING

Most treadmill problems can be solved by following the steps below. Find the symptom that applies, and follow the steps listed. If further assistance is needed, please call our Customer Service Department.

PROBLEM: The power does not turn on

- SOLUTION:**
- Make sure that the power cord is plugged into a properly earthed outlet. (See on page 9.) If an extension cord is needed, use only a 3-conductor, 1 mm² (14-gauge) cord that is no longer than 1.5 m (5 ft.).
 - After the power cord has been plugged in, make sure that the key is fully inserted into the console.
 - Check the circuit breaker located on the treadmill near the power cord. If the switch protrudes as shown, the circuit breaker has tripped. To reset the circuit breaker, wait for five minutes and then press the switch back in.
 - Check the on/off switch located on the treadmill near the power cord. The switch must be in the on position.

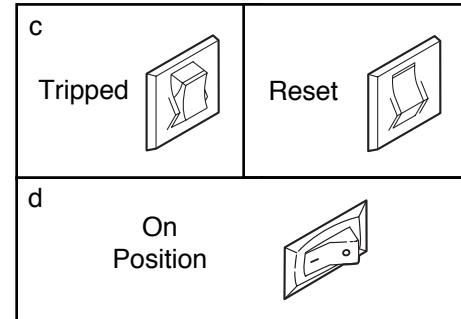

PROBLEM: The power turns off during use

- SOLUTION:**
- Check the circuit breaker located on the treadmill frame near the power cord (see c. above). If the circuit breaker has tripped, wait for five minutes and then press the switch back in.
 - Make sure that the power cord is plugged in. If the power cord is plugged in, unplug it, wait for five minutes, and then plug it back in.
 - Make sure that the on/off switch is in the on position.
 - If the treadmill still will not run, please call our Customer Service Department.

PROBLEM: The speed display on the console does not function properly

- SOLUTION:**
- Remove the key and **UNPLUG THE POWER CORD**. Carefully lower the Uprights (64) to the floor. Remove the three indicated Small Screws (37).

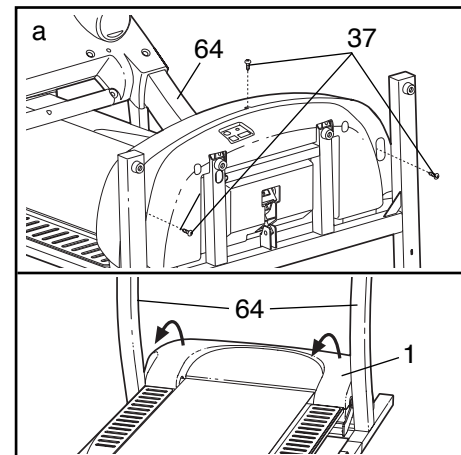

Raise the Uprights (64) to the vertical position. Pivot the Hood (1) off.

BEFORE YOU BEGIN

Congratulations for selecting the new PROFORM® 10.5 QM treadmill. The 10.5 QM treadmill combines advanced technology with innovative design to help you get the most from your exercise in the convenience and privacy of your home. And when you're not exercising, the unique 10.5 QM treadmill can be folded up, requiring less than half the floor space of other treadmills.



For your benefit, read this manual carefully before using the treadmill. If you have questions after read-

ing this manual, please call our Customer Service Department at **08457 089 009**. To help us assist you, please note the product model number and serial number before calling. The model number of the treadmill is PETL61021. The serial number can be found on a decal attached to the treadmill (see the front cover of this manual for the location).

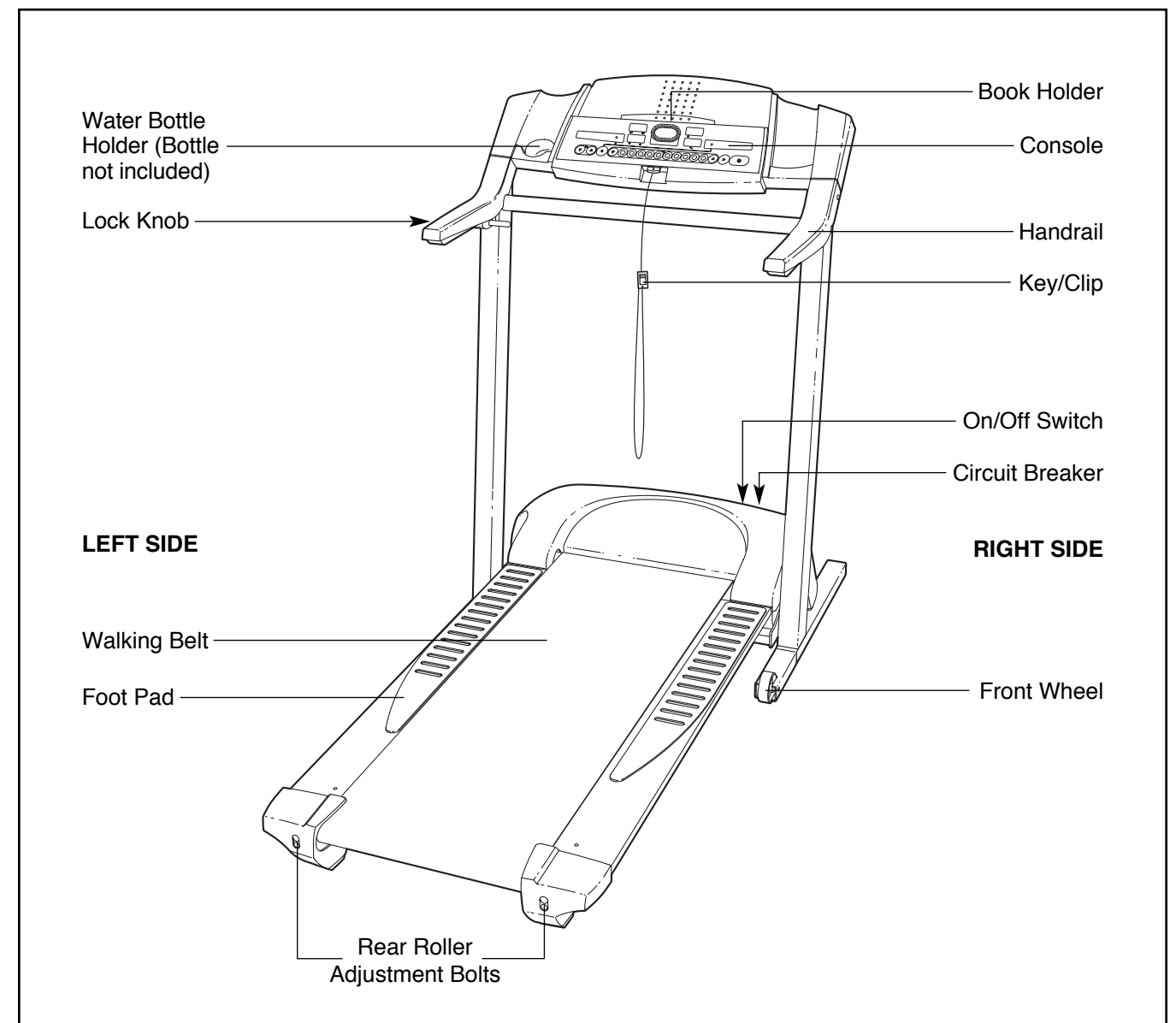
Before reading further, please review the drawing below and familiarise yourself with the parts that are labelled.

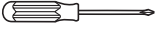

ASSEMBLY

Assembly requires two people. Set the treadmill in a cleared area and remove all packing materials. Do not dispose of the packing materials until assembly is completed. **Assembly requires your own Phillips screwdriver**  **and rubber mallet** .

Note: The underside of the treadmill walking belt is coated with high-performance lubricant. During shipping, a small amount of lubricant may be transferred to the top of the walking belt or the shipping carton. This is a normal condition and does not affect treadmill performance. If there is lubricant on top of the walking belt, simply wipe off the lubricant with a soft cloth and a mild, non-abrasive cleaner.

WARNING: Do not plug in the power cord until the treadmill is completely assembled.

1. With the help of a second person, carefully raise the treadmill to the upright position as shown.

Insert one of the Extension Legs (55) into the treadmill as shown. Make sure that the Extension Leg is turned so the Base Pad (44) is on the bottom. If necessary, tip the Uprights (64) forward as you insert the Extension Leg.

Insert the other Extension Leg (not shown) in the same way.

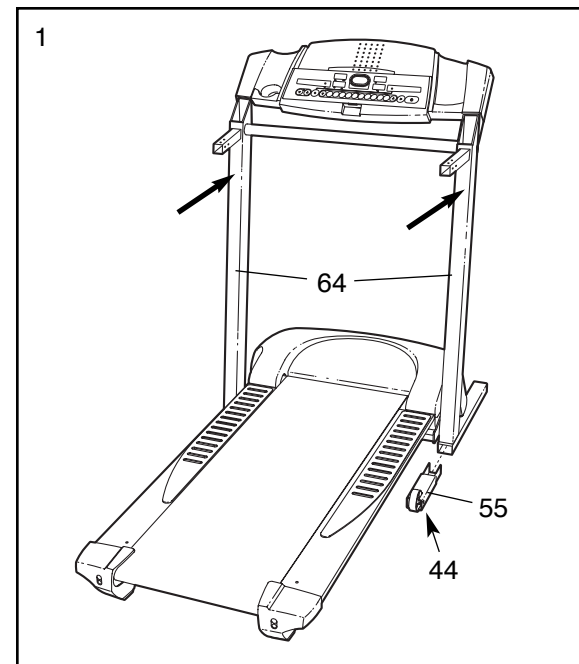

2. With the help of a second person, carefully lower the Uprights (64) as shown. Note: It may be helpful to place your foot on one of the Wheels (58) as you tip the Uprights. **Make sure that the Extension Legs (55) remain in the Uprights.**

Attach each Extension Leg (55) with a Screw (35), a Long Screw (107), and a Base Pad (44) as shown.

Note: One replacement Base Pad (44) may be included. If a Base Pad becomes worn and needs to be replaced, use the replacement Base Pad.

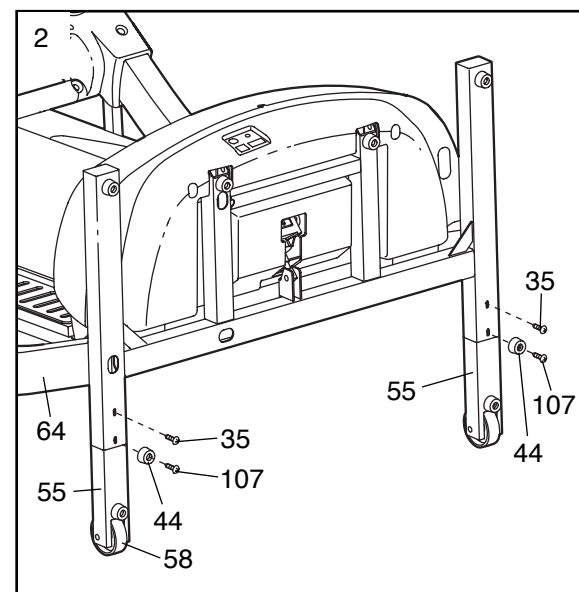

HOW TO FOLD AND MOVE THE TREADMILL

HOW TO FOLD THE TREADMILL FOR STORAGE

Before folding the treadmill, adjust the incline to the lowest position. If this is not done, the treadmill may be permanently damaged. Next, unplug the power cord. **CAUTION: You must be able to safely lift 20 kg (45 lbs.) in order to raise, lower, or move the treadmill.**

1. Hold the treadmill with your hands in the locations shown. **CAUTION: To decrease the possibility of injury, bend your legs and keep your back straight. As you raise the treadmill, lift with your legs rather than your back.** Raise the treadmill halfway to the vertical position.

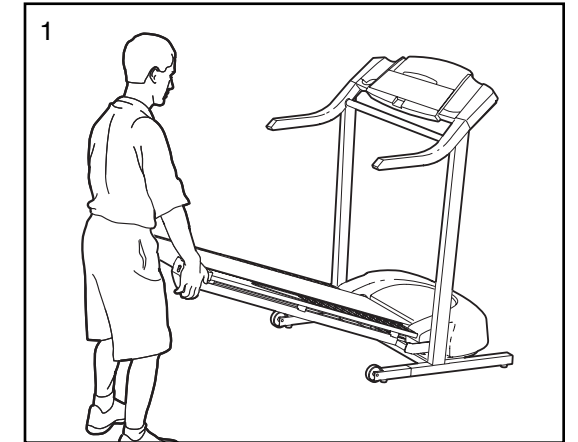

2. Move your right hand to the position shown and hold the treadmill firmly. Using your left hand, pull the latch knob to the left and hold it. Raise the treadmill until the catch is past the latch pin. Slowly release the latch knob. **Make sure that the plate is held securely by the latch pin.**

To protect the floor or carpet from damage, place a mat under the treadmill. Keep the treadmill out of direct sunlight. Do not leave the treadmill in the storage position in temperatures above 30° C (85° F).

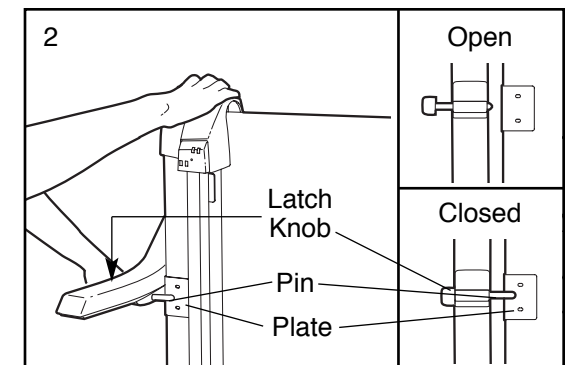

HOW TO MOVE THE TREADMILL

Before moving the treadmill, convert the treadmill to the storage position as described above. **Make sure that the plate is held securely by the latch pin.**

1. Hold the handrails and place one foot against a wheel.
2. Tilt the treadmill back until it rolls freely on the wheels. Carefully move the treadmill to the desired location. **Never move the treadmill without tipping it back. To reduce the risk of injury, use extreme caution whilst moving the treadmill. Do not attempt to move the treadmill over an uneven surface.**
3. Place one foot on a wheel, and carefully lower the treadmill until it is resting in the storage position.



HOW TO LOWER THE TREADMILL FOR USE

1. Refer to drawing 2 above. Hold the upper end of the treadmill with your right hand. Pull the latch knob to the left and hold it. Pivot the treadmill down until the frame is past the pin. Slowly release the latch knob.
2. Refer to drawing 1 above. Hold the treadmill firmly with both hands, and **slowly** lower the treadmill to the floor. **CAUTION: To decrease the possibility of injury, bend your legs and keep your back straight.**

8 Follow your progress with the track and the four displays.

See step 5 on page 11.

9 When the program is finished, remove the key.

Step onto the foot rails and remove the key from the console. Keep the key in a secure place. **Note: If the displays and various indicators on the console remain lit after the key is removed, the console is in the “demo” mode. Refer to the instructions at the right and turn off the demo mode.**

When you are finished using the treadmill, move the on/off switch near the power cord to the off position.

THE INFORMATION MODE/DEMO MODE

The console features an information mode that keeps track of the total number of hours that the treadmill has been operated and the total number of miles that the walking belt has moved. The information mode also allows you to switch the console from miles per hour to kilometres per hour. In addition, the information mode allows you to turn on and turn off the demo mode.

To select the information mode, hold down the Stop button whilst inserting the key into the console. When the information mode is selected, the following information will be shown:

The Distance/Laps display will show the total number of miles (or kilometres) that the walking belt has moved.



The Time/Incline display will show the total number of hours the treadmill has been used.



An E for english miles or an M for metric kilometres, will appear in the Speed display. Press the Speed Δ button to change the unit of measurement.

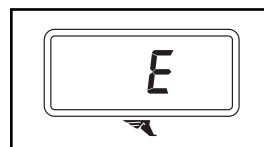

IMPORTANT: The Cals./Watts/Pulse display should be blank. If a “d” appears in the display, the console is in the “demo” mode. This mode is intended to be used only when a treadmill is displayed in a store. When the console is in the demo mode, the power cord can be plugged in, the key can be removed from the console, and the displays and indicators on the console will automatically light in a preset sequence, although the buttons on the console will not operate. **If a “d” appears in the Cals./Watts/Pulse display when the information mode is selected, press the Speed ∇ button so the display is blank.**

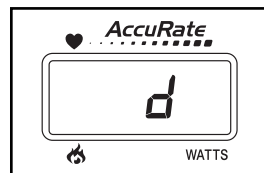

To exit the information mode, remove the key from the console.

3. With the help of a second person, carefully tip the Uprights (64) back to the vertical position.

Attach the Latch Assembly (32) and the Latch Spacer (46) to the left Upright (64) with two Screws (35) as shown.

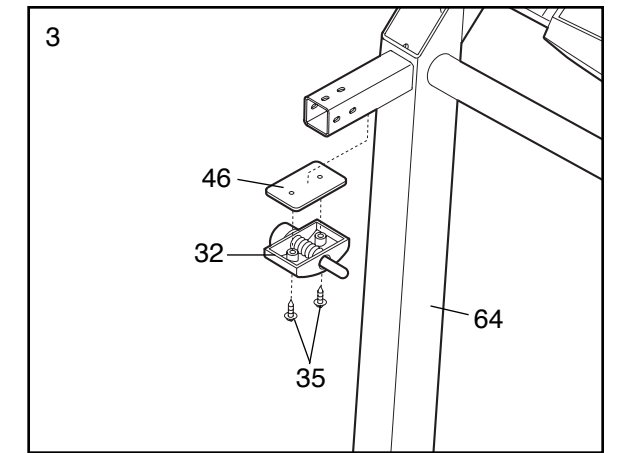

4. Insert a Handrail Extension (34) into the post on the left Upright (64). Align the holes in the Handrail Extension with the holes in the post. If necessary, tap the Handrail Extension with a rubber mallet to fully insert it. Next, attach the Handrail Extension by tightening **three** Screws (35) into the indicated holes. **Note: If there is only one hole in the top of the post, tighten the third Screw into the hole in the left side of the post.**

Identify the Left Foam Grip (31), which has a **large** cutout in the right side. Slide the Left Foam Grip as far as possible onto the post on the left Upright (64). It may be helpful to apply soapy water to the Handrail Extension (34).

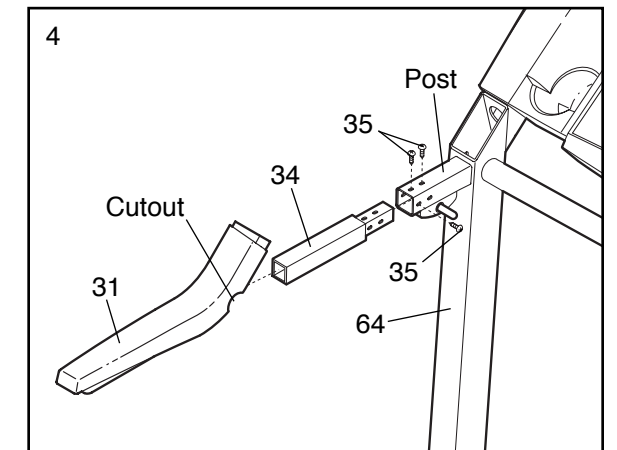

5. Make sure that the front edge of the Left Foam Grip (31) is under the Console Base (38) as shown. Tighten a Screw (35) into the side of the Left Foam Grip as shown. **Note: You may need to pull on the side of the Left Foam Grip to align the Screw with the hole in the Upright (64).**

Attach the Right Foam Grip (not shown) and the other Handrail Extension (not shown) as described in step 4 and this step.

Note: Extra screws may be included.

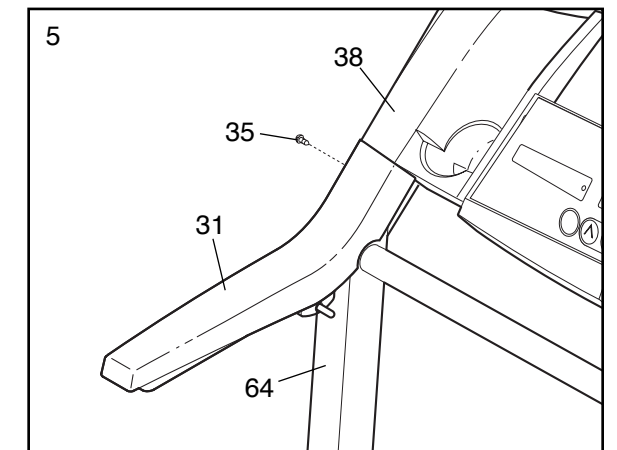

6. **Make sure that all parts are tightened before you use the treadmill.** Keep the included allen wrench in a secure place. The allen wrench is used to adjust the walking belt (see page 21). To protect the floor or carpet, place a mat under the treadmill.

HOW TO USE THE CHEST PULSE SENSOR

HOW TO PUT ON THE CHEST PULSE SENSOR

The chest pulse sensor consists of two components: the chest strap and the sensor unit (see the drawing below). Insert the tab on one end of the chest strap into one end of the sensor unit, as shown in the inset drawing. Press the end of the sensor unit under the buckle on the chest strap. The tab should be flush with the front of the sensor unit.

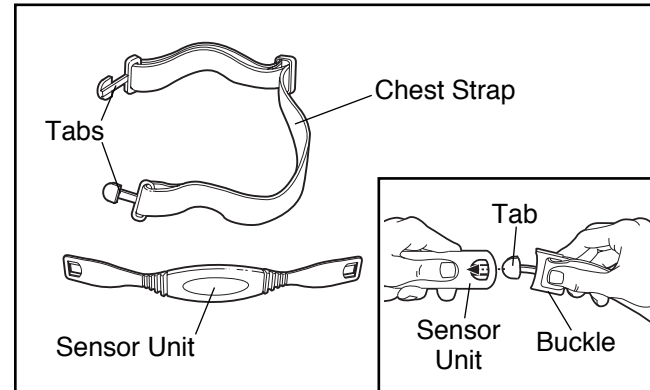

Next, wrap the chest pulse sensor around your chest and attach the other end of the chest strap to the sensor unit. Adjust the length of the chest strap, if necessary. The chest pulse sensor should be under your clothes, tight against your skin, and as high under the pectoral muscles or breasts as is comfortable. Make sure that the logo on the sensor unit is facing forward and is right-side-up.

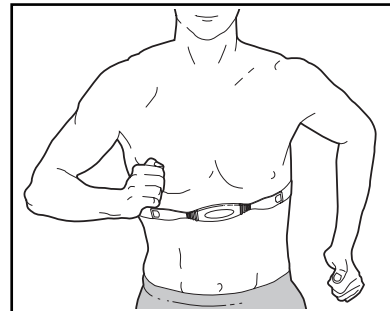

Pull the sensor unit away from your body a few inches and locate the two electrode areas on the inner side (the electrode areas are covered by shallow ridges). Using saline solution such as saliva or contact lens solution, wet both electrode areas. Return the sensor unit to a position against your chest.

CHEST PULSE SENSOR CARE AND MAINTENANCE

- Thoroughly dry the chest pulse sensor after each use. The chest pulse sensor is activated when the electrode areas are wetted and the heart rate monitor is put on; the chest pulse sensor shuts off when it is removed and the electrode areas are

dried. If the chest pulse sensor is not dried after each use, it may remain activated longer than necessary, draining the battery prematurely.

- Store the chest pulse sensor in a warm, dry place. Do not store the chest pulse sensor in a plastic bag or other container that may trap moisture.
- Do not expose the chest pulse sensor to direct sunlight for extended periods of time; do not expose it to temperatures above 50° C (122° F) or below -10° C (14° F).
- Do not excessively bend or stretch the sensor unit when using or storing the chest pulse sensor.
- Clean the sensor unit using a damp cloth—never use alcohol, abrasives, or chemicals. The chest strap may be hand washed and air dried.

CHEST PULSE SENSOR TROUBLESHOOTING

The instructions on the following pages explain how the chest pulse sensor is used with the console. If the chest pulse sensor does not function properly, try the steps below.

- Make sure that you are wearing the chest pulse sensor as described at the left. Note: If the chest pulse sensor does not function when positioned as described, move it slightly lower or higher.
- Use saline solution such as saliva or contact lens solution to wet the two electrode areas on the sensor unit. If heart rate readings do not appear until you begin perspiring, re-wet the electrode areas.
- As you walk or run on the treadmill, position yourself near the centre of the walking belt. **For the console to display heart rate readings, the user must be within arm's length of the console.**
- The chest pulse sensor is designed to work with people who have normal heart rhythms. Heart rate reading problems may be caused by medical conditions such as premature ventricular contractions (pvc's), tachycardia bursts, and arrhythmia.
- The operation of the chest pulse sensor can be affected by magnetic interference caused by high power lines or other sources. If it is suspected that this is a problem, try relocating the treadmill.
- The CR2032 battery may need to be replaced (see page 22).

HOW TO USE PROGRAMS DIRECTLY FROM OUR WEB SITE

Our Web site at www.iFIT.com allows you to access basic programs, audio programs, and video programs directly from the internet. Additional options are soon to be available. See www.iFIT.com for details.

To use programs from our Web site, the treadmill must be connected to your home computer. See HOW TO CONNECT YOUR COMPUTER on page 14. In addition, you must have an internet connection and an internet service provider. A list of specific system requirements will be found on our Web site.

Next, make sure that the on/off switch near the power cord is in the on position. In addition, make sure that the power cord is properly plugged in (see page 9).

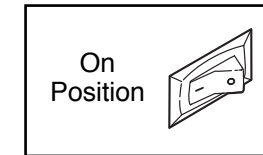

Follow the steps below to use a program from our Web site.

1 Insert the key fully into the console.

When the key is inserted, the four displays and various indicators on the console will light.

2 Press the Mode button.

When the key is inserted, the manual mode will be selected. To use a program from our Web site, press the Mode button. The iFIT.com indicator will light.

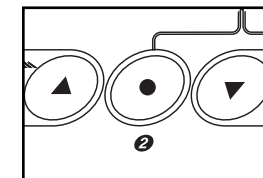

3 Go to your computer and start an internet connection.

4 Start your web browser, if necessary, and go to our Web site at www.iFIT.com.

5 Follow the desired links on our Web site to select a program.

Read and follow the on-line instructions for using a program.

6 Follow the on-line instructions to start the program.

When you start the program, an on-screen countdown will begin.

7 Return to the treadmill and stand on the foot rails. Find the clip attached to the key and slide the clip onto the waistband of your clothes.

When the on-screen countdown ends, the program will begin and the walking belt will begin to move. Hold the handrails, step onto the walking belt, and begin walking.

During the program, an electronic "chirping" sound will alert you when the speed and/or incline of the treadmill is about to change. **CAUTION: Always listen for the "chirp" and be prepared for speed and/or incline changes.**

If the speed or incline settings are too high or too low, you can manually override the settings at any time by pressing the Speed or Incline buttons on the console. However, **when the next "chirp" is heard, the speed and/or incline will change to the next settings of the program.**

To stop the program at any time, press the Stop button on the console. The Time/Incline display will begin to flash. To restart the program, press the Start button or the Speed Δ button. After a moment, the walking belt will begin to move at 1 mph. **When the next "chirp" is heard, the speed and incline will change to the next settings of the program.**

When the program is completed, the walking belt will stop and the Time/Incline display will begin to flash. Note: To use another program, press the Stop button and go to step 5 above.

Note: If the speed or incline of the treadmill does not change when a "chirp" is heard, make sure that the iFIT.com indicator is lit and that the Time/Incline display is not flashing. In addition, make sure that the audio cable is properly connected, that it is fully plugged in, and that it is not wrapped around a power cord.

4 Press the PLAY button on your CD player or VCR.

A moment after the button is pressed, your personal trainer will begin guiding you through your workout. Simply follow your personal trainer's instructions. Note: If the Time/Incline display is flashing, press the Start button or the Speed Δ button on the console. The treadmill will not respond to a CD or video program when the Time/Incline display is flashing.

During the CD or video program, an electronic "chirping" sound will alert you when the speed and/or incline of the treadmill is about to change. **CAUTION: Always listen for the "chirp" and be prepared for speed and/or incline changes. In some instances, the speed and/or incline may change before the personal trainer describes the change.**

If the speed or incline settings are too high or too low, you can manually override the settings at any time by pressing the Speed or Incline buttons on the console. However, **when the next "chirp" is heard, the speed and/or incline will change to the next settings of the CD or video program.**

To stop the program at any time, press the Stop button on the console. The Time/Incline display will begin to flash. To restart the program, press the Start button or the Speed Δ button again. After a moment, the walking belt will begin to move at 1 mph. **When the next "chirp" is heard, the speed and incline will change to the next settings of the CD or video program.** The program can also be stopped by pressing the Stop button on your CD player or VCR.

When the CD or video program is completed, the walking belt will stop and the Time/Incline display will begin to flash. Note: To use another CD or video program, press the Stop button or remove the key and go to step 1 on page 15.

Note: If the speed or incline of the treadmill does not change when a "chirp" is heard:

- make sure that the iFIT.com indicator is lit and that the Time/Incline display is not flashing. If the display is flashing, press the Start button or the Speed Δ button on the console.
- adjust the volume of your CD player or VCR. If the volume is too high or too low, the console may not detect the program signals.
- make sure that the audio cable is properly connected, that it is fully plugged in, and that it is not wrapped around a power cord.
- if you are using your portable CD player and the CD skips, set the CD player on the floor or another flat surface instead of on the console.

5 Follow your progress with the track and the four displays.

See step 5 on page 11.

6 When the iFIT.com CD or video program is finished, remove the key.

Step onto the foot rails and remove the key from the console. Keep the key in a secure place. **Note: If the displays and indicators on the console remain lit after the key is removed, the console is in the "demo" mode. Refer to page 18 and turn off the demo mode.**

CAUTION: Always remove iFIT.com CD's and videocassettes from your CD player or VCR when you are finished using them.

When you are finished using the treadmill, move the on/off switch near the power cord to the off position.

OPERATION AND ADJUSTMENT

THE PERFORMANT LUBE™ WALKING BELT

Your treadmill features a walking belt coated with PERFORMANT LUBE™, a high-performance lubricant. **IMPORTANT: Never apply silicone spray or other substances to the walking belt or the walking platform. Such substances will deteriorate the walking belt and cause excessive wear.**

HOW TO PLUG IN THE POWER CORD

This product must be earthed. If it should malfunction or break down, earthing provides a path of least resistance for electric current to reduce the risk of electric shock. This product is equipped with a cord having an equipment-earthing conductor and an earthing plug.

Two power cords are included. Select the one that will fit your outlet. Refer to drawing 1, and plug the indicated end of the power cord into the socket on the treadmill. Next, lift the indicated tab on the ferrite box and clamp the ferrite box around the power cord. The ferrite box should not be allowed to slide along the power cord. Please fasten the included plastic tie just behind the ferrite box and cut off the excess plastic tie. Refer to drawing 2. Plug the power cord into an appropriate outlet that is properly installed and earthed in accordance with all local codes and ordinances. Note: In Italy, an adaptor (not included) must be used between the power cord and the outlet. **Important: The treadmill is not compatible with GFCI-equipped outlets.**

If the power cord is damaged, it must be replaced with a manufacturer-recommended power cord.

⚠ DANGER: Improper connection of the equipment-earthing conductor can result in an increased risk of electric shock. Check with a qualified electrician or serviceman if you are in doubt as to whether the product is properly earthed. Do not modify the plug provided with the product—if it will not fit the outlet, have a proper outlet installed by a qualified electrician.

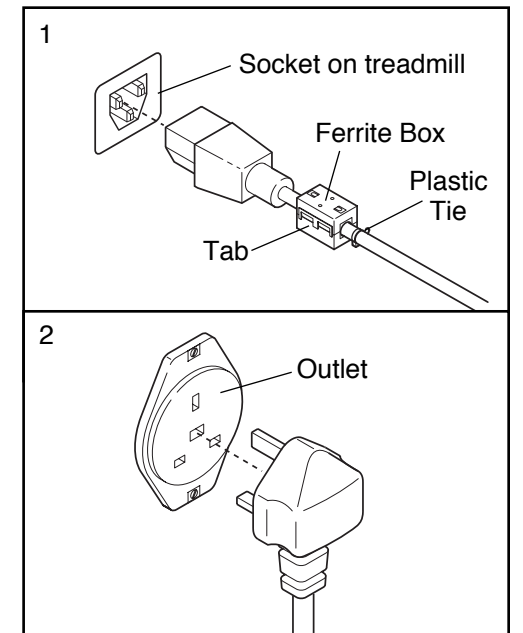

CONSOLE DIAGRAM

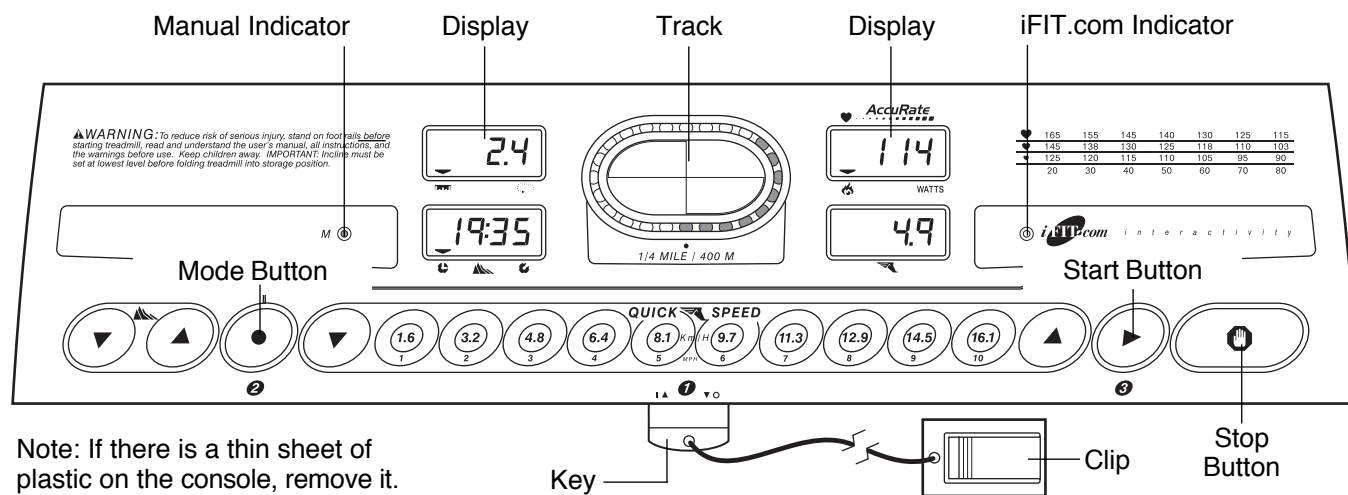

Note: If there is a thin sheet of plastic on the console, remove it.

CAUTION: Before operating the console, read the following precautions.

- Do not stand on the walking belt when turning on the power.
- Always wear the clip (see the drawing above) whilst operating the treadmill.
- Adjust the speed in small increments in order to avoid sudden jumps in speed.
- To reduce the possibility of electric shock, keep the console dry. Avoid spilling liquids on the console and place only a sealed water bottle in the water bottle holder.

FEATURES OF THE CONSOLE

The treadmill console offers a selection of features designed to help you get the most from your exercise. When the manual mode of the console is selected, the speed and incline of the treadmill can be changed with a touch of a button. As you exercise, the track and the four displays will provide continuous exercise feedback. You can even measure your heart rate using the chest pulse sensor.

The console also features iFIT.com interactive technology. Having iFIT.com interactive technology is like having a personal trainer in your home. Using a stereo audio cable (available at electronics stores), you can connect the treadmill to your home stereo, portable stereo, computer, or VCR and play special iFIT.com CD and videocassette programs (iFIT.com CDs and videocassettes are available separately). iFIT.com CD and videocassette programs automatically control the treadmill and prompt you to vary your pace as a personal trainer coaches you through every step of your workout. High-energy music provides added motivation. **To purchase iFIT.com CDs and videocassettes, visit our Web site at www.iFIT.com.**

With the treadmill connected to your computer, you can also go to our Web site at www.iFIT.com and access programs directly from the internet. **Explore www.iFIT.com for more information.**

To use the manual mode of the console, follow the steps beginning on page 11. **To use iFIT.com CD or video programs**, refer to page 15. **To use iFIT.com programs directly from our Web site**, see page 17.

HOW TO CONNECT YOUR VCR

Note: If your VCR has an unused AUDIO OUT jack, see instruction A below. If the AUDIO OUT jack is being used, see instruction B. If you have a TV with a built-in VCR, see instruction B. If your VCR is connected to your home stereo, see HOW TO CONNECT YOUR HOME STEREO on page 14.

A. Plug one end of the audio cable into the jack on the front of the treadmill near the power cord. Plug the other end of the cable into the adaptor. Plug the adaptor into the AUDIO OUT jack on your VCR.

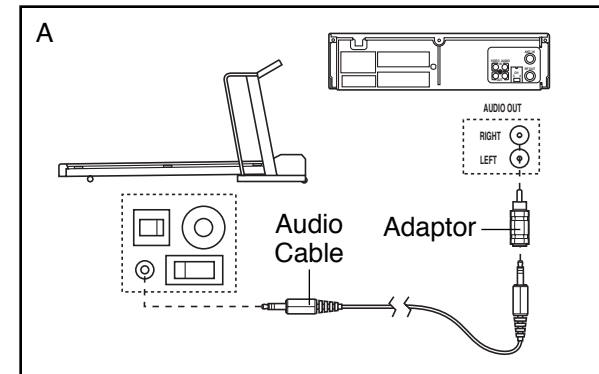

B. Plug one end of the audio cable into the jack on the front of the treadmill near the power cord. Plug the other end of the cable into the adaptor. Plug the adaptor into an RCA Y-adaptor (available at electronics stores). Next, remove the wire that is currently plugged into the AUDIO OUT jack on your VCR and plug the wire into the unused side of the Y-adaptor. Plug the Y-adaptor into the AUDIO OUT jack on your VCR.

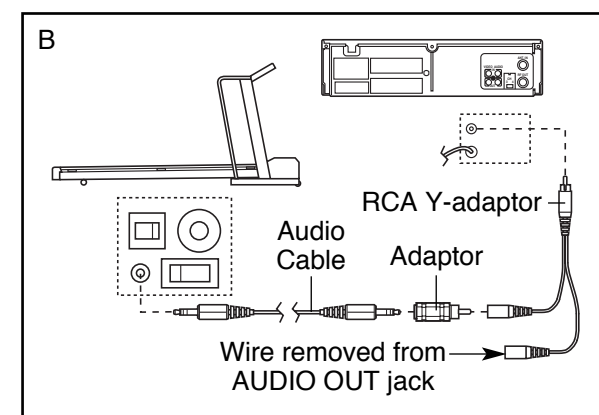

HOW TO USE iFIT.COM CD AND VIDEO PROGRAMS

To use iFIT.com CD's or videocassettes, the treadmill must be connected to your portable CD player, portable stereo, home stereo, computer with CD player, or VCR. See HOW TO CONNECT THE COMPUTER TO YOUR CD PLAYER, VCR, OR COMPUTER on page 13. **For information about iFIT.com CD's or videocassettes, send an e-mail to workouts@iFIT.com.**

Make sure that the on/off switch near the power cord is in the on position. In addition, make sure that the power cord is properly plugged in (see page 9).

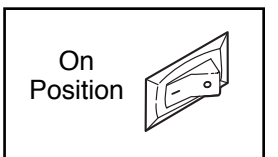

When you are ready to begin exercising, step onto the foot rails of the treadmill. Find the clip attached to the key (see the drawing on page 10), and slide the clip onto the waistband of your clothes. Follow the steps below to use an iFIT.com CD or video. **Note: The instructions included in the CD case describe how to use the CD with a variety of PROFORM treadmills. Some instructions may not apply to this treadmill.**

1 Insert the key fully into the console.

When the key is inserted, the four displays and various indicators on the console will light.

2 Press the Mode button.

When the key is inserted, the manual mode will be selected. To use an iFIT.com CD or video program, press the Mode button. The iFIT.com indicator will light.

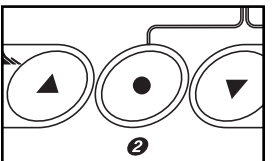

3 Insert the iFIT.com CD or videocassette.

If you are using an iFIT.com CD, insert the CD into your CD player. If you are using an iFIT.com videocassette, insert the videocassette into your VCR.

HOW TO CONNECT YOUR HOME STEREO

Note: If your stereo has an unused LINE OUT jack, see instruction A below. If the LINE OUT jack is being used, see instruction B.

- A. Plug one end of the audio cable into the jack on the front of the treadmill near the power cord. Plug the other end of the cable into the adaptor. Plug the adaptor into the LINE OUT jack on your stereo.

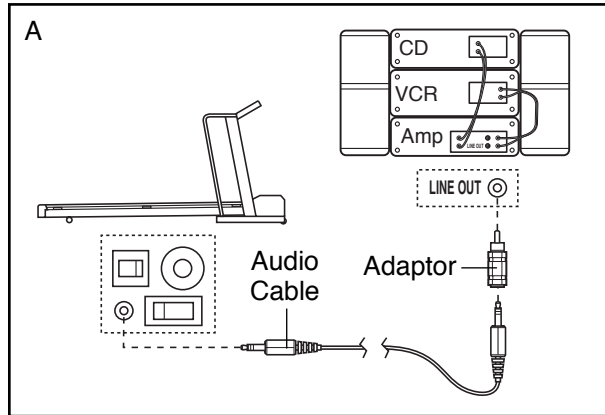

- B. Plug one end of the audio cable into the jack on the front of the treadmill near the power cord. Plug the other end of the cable into the adaptor. Plug the adaptor into an RCA Y-adaptor (available at electronics stores). Next, remove the wire that is currently plugged into the LINE OUT jack on your stereo and plug the wire into the unused side of the Y-adaptor. Plug the Y-adaptor into the LINE OUT jack on your stereo.

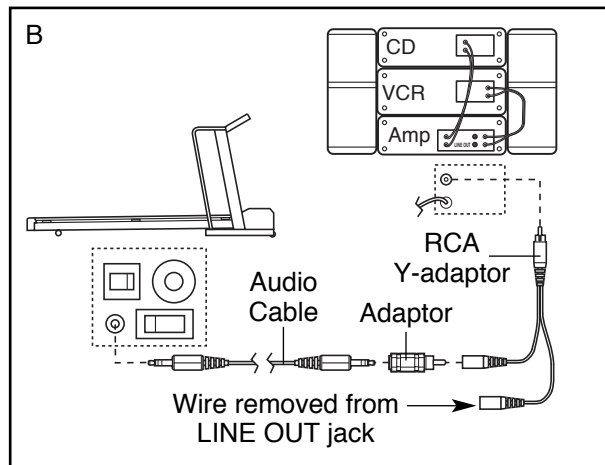

HOW TO CONNECT YOUR COMPUTER

Note: If your computer has a 3.5mm LINE OUT jack, see instruction A. If your computer has only a PHONES jack, see instruction B.

- A. Plug one end of the audio cable into the jack on the front of the treadmill near the power cord. Plug the other end of the cable into the LINE OUT jack on your computer.

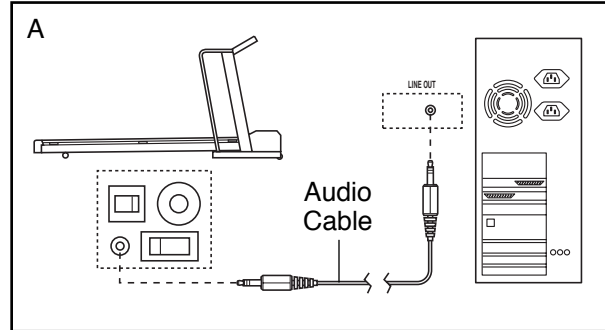

- B. Plug one end of the audio cable into the jack on the front of the treadmill near the power cord. Plug the other end of the cable into the splitter. Plug the splitter into the PHONES jack on your computer. Plug your headphones or speakers into the other side of the splitter.

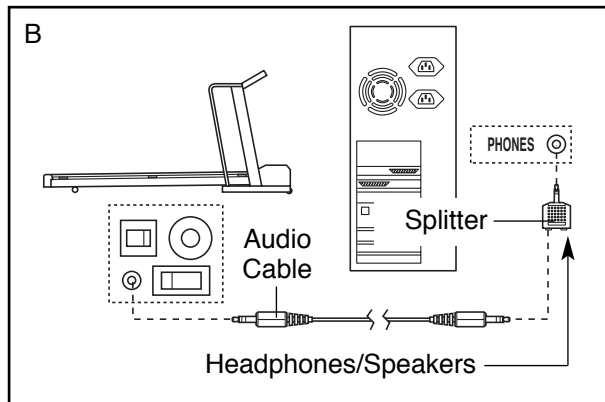

GETTING STARTED

Before operating the console, make sure that the on/off switch near the power cord is in the on position. Next, make sure that the key is removed from the console and the power cord is properly plugged in (see page 9).

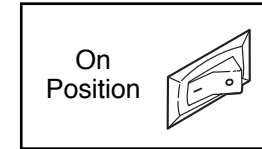

When you are ready to begin exercising, step onto the foot rails of the treadmill. Find the clip attached to the key (see the drawing on page 10), and slide the clip onto the waistband of your clothes. Next, insert the key fully into the console. **Test the clip by carefully taking a few steps backward until the key is pulled from the console. If the key is not pulled from the console, adjust the position of the clip as needed.**

Note: The console can display speed and distance in either miles or kilometres (see Speed Display on page 12). For simplicity, all instructions in this manual refer to miles.

HOW TO USE THE MANUAL MODE

1 Insert the key fully into the console.

When the key is inserted, the four displays and various indicators on the console will light.

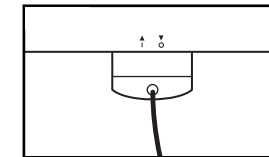

2 Select the manual mode.

When the key is inserted, the manual mode will be selected, as shown by the manual (M) indicator. If the iFIT.com indicator is lit, press the Mode button to select the manual mode.

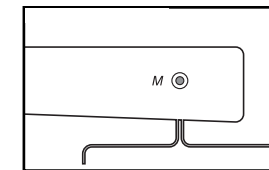

3 Press the Start button or the Speed Δ button to start the walking belt.

A moment after the button is pressed, the walking belt will begin to move at 1 mph. Hold the hand-rails and carefully begin walking. As

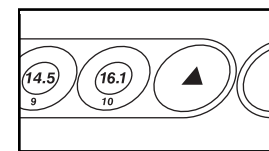

you exercise, change the speed of the walking belt as desired by pressing the Speed Δ and ∇ buttons. To change the speed setting quickly, press the Quick Speed buttons. Note: After the buttons are pressed, it will take a moment for the walking belt to reach the selected speed setting.

To stop the walking belt, press the Stop button. The Time/Incline display will begin to flash. To restart the walking belt, press the Start button or the Speed Δ button.

4 Change the incline of the treadmill as desired.

To change the incline of the treadmill, press the Incline buttons. Each time a button is pressed, the incline will change by 0.5%. The buttons can be held down to change the incline rapidly. Note: After the Incline buttons are pressed, it will take a moment for the treadmill to reach the selected incline setting.

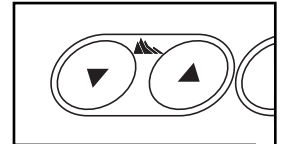

5 Follow your progress with the track and the four displays.

The track—The track in the centre of the console represents a distance of 1/4 mile. As you exercise, the indicators around the track will light one at a time until you have walked or run 1/4 mile. A new lap will then begin.

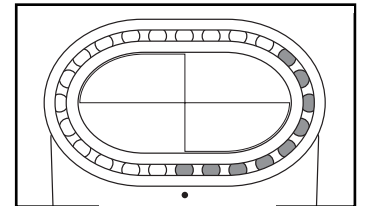

Distance/Laps display

—This display shows the distance that you have walked or run and the number of laps you have completed (one lap equals 1/4 mile). The display will alternate between one number and the other every few seconds, as shown by the arrows in the display.

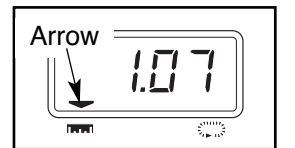

Time/Incline display—

This display shows the elapsed time and the incline level of the treadmill. The display will alternate between one number and the other every few seconds, as shown by the arrows in the display. Note: When the Incline buttons are pressed, this display will show the current incline setting.



Cals/Watts/Pulse display—

This display shows the approximate number of calories you have burned and your power output in watts. Every few seconds, the display will change from one number to the other, as shown by the arrows in the display. This display will also show your heart rate when you wear the chest pulse sensor.

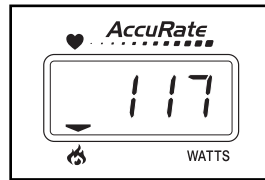

Speed display—This display shows the speed of the walking belt.



Note: The console can display speed and distance in either miles or kilometres. To see which unit of measurement is selected, hold down the Stop button whilst inserting the key into the console. An E for english miles or an M for metric kilometres will appear in the Speed display. Press the Speed Δ button to change the unit of measurement. When the desired unit of measurement is selected, remove and then reinsert the key.

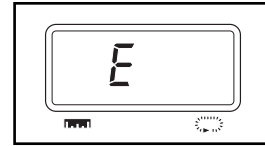

6 When you are finished exercising, remove the key.

Step onto the foot rails, press the Stop button, and remove the key from the console. Keep the key in a secure place. **Note: If the displays and indicators on the console remain lit after the key is removed, the console is in the “demo” mode. Refer to page 18 and turn off the demo mode.**

When you are finished using the treadmill, move the on/off switch near the power cord to the off position.

HOW TO CONNECT THE TREADMILL TO YOUR CD PLAYER, VCR, OR COMPUTER

To use **iFIT.com CD's**, the treadmill must be connected to your portable CD player, portable stereo, home stereo, or computer with CD player. See pages 13 and 14 for connecting instructions. **To use iFIT.com videocassettes**, the treadmill must be connected to your VCR. See page 15 for connecting instructions. **To use iFIT.com programs directly from our internet site**, the treadmill must be connected to your home computer. See page 14 for connecting instructions.

HOW TO CONNECT YOUR PORTABLE CD PLAYER

Note: If your CD player has separate LINE OUT and PHONES jacks, see instruction A below. If your CD player has only one jack, see instruction B.

A. Plug one end of the audio cable into the jack on the front of the treadmill near the power cord. Plug the other end of the cable into the LINE OUT jack on your CD player. Plug your headphones into the PHONES jack.

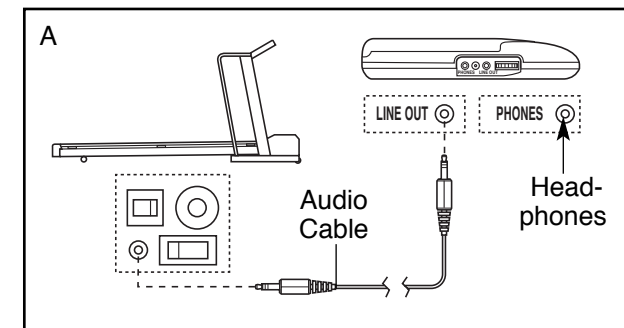

B. Plug one end of the audio cable into the jack on the front of the treadmill near the power cord. Plug the other end of the cable into the splitter. Plug the splitter into the PHONES jack on your CD player. Plug your headphones into the other side of the splitter.

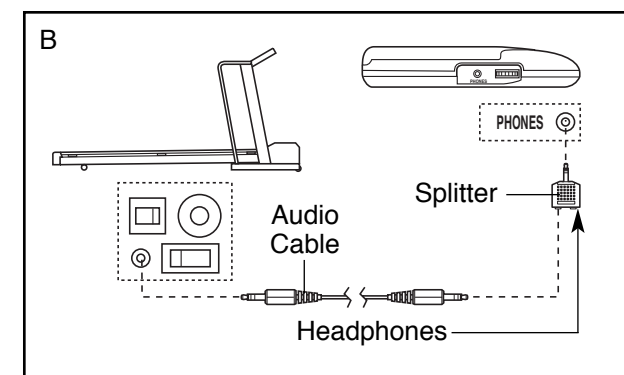

HOW TO CONNECT YOUR PORTABLE STEREO

Note: If your stereo has an RCA-type AUDIO OUT jack, see instruction A below. If your stereo has a 3.5mm LINE OUT jack, see instruction B. If your stereo has only a PHONES jack, see instruction C.

A. Plug one end of the audio cable into the jack on the front of the treadmill near the power cord. Plug the other end of the cable into the adaptor. Plug the adaptor into an AUDIO OUT jack on your stereo.

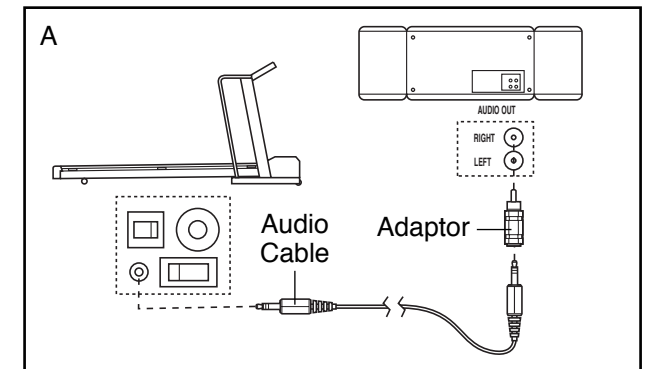

B. Plug one end of the audio cable into the jack on the front of the treadmill near the power cord. Plug the other end of the cable into the LINE OUT jack on your stereo.

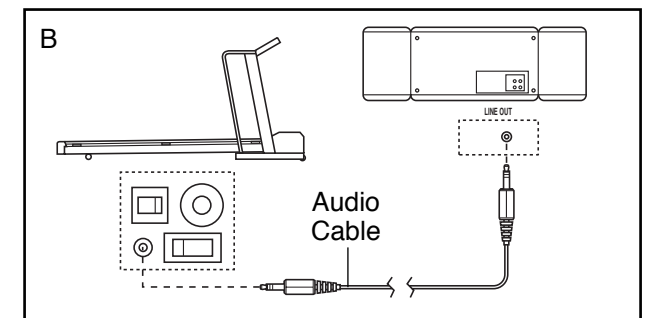

C. Plug one end of the audio cable into the jack on the front of the treadmill near the power cord. Plug the other end of the cable into the splitter. Plug the splitter into the PHONES jack on your stereo. Plug your headphones into the other side of the splitter.

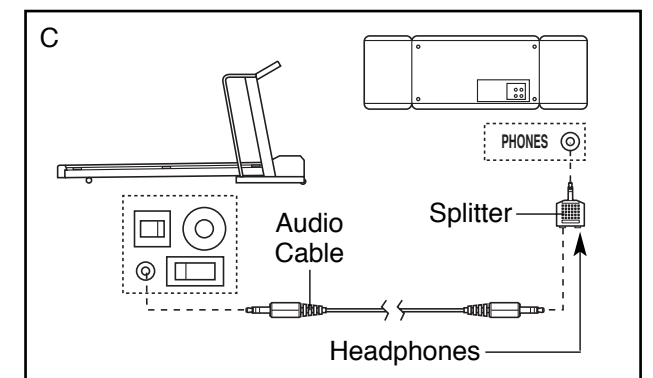

PART LIST—Model No. PETL61021

R0603A

To locate the parts listed below, refer to the EXPLODED DRAWING attached in the centre of this manual.

Key No.	Qty.	Description	Key No.	Qty.	Description	Key No.	Qty.	Description
1	1	Motor Hood	46	1	Latch Spacer	91	2	Rear Roller Adj. Bolt
2	3	Nylon Washer	47	1	Ground Screw	92	2	Roller Adj. Washer
3	8	Pivot Nut	48	1	Ground Washer	93	1	Rear Endcap (Right)
4	1	Motor Belt	49	1	Upright Wire	94	1	Allen Wrench
5*	1	Motor Assembly	50	1	Pulse Receiver	95	1	Rear Foot (Left)
6	1	Flywheel	51	1	Frame	96	1	Rear Endcap (Left)
7	1	Motor	52	1	Incline Motor Bolt	97	1	Warning Decal
8	2	Frame Spacer	53	2	Caution Decal	98	2	Latch Plate Screw
9	4	Console Screw	54	2	Motor Pivot Bushing	99	1	Latch Plate
10	1	Front Roller Adj. Bolt	55	2	Extension Leg	100*	2	Extension Leg Assembly
11	1	Motor Pivot Bolt	56	2	Wheel Bolt	101	1	Magnet
12	2	Lift Frame Pivot Bolt	57	2	Roller Star Washer	102	1	Belly Pan Clip
13	1	Chest Strap	58	2	Wheel	103	1	Chest Pulse Sensor
14	1	Motor Tension Nut	59	1	Incline Motor	104	1	Splitter
15	1	Motor Washer	60	1	Stop Bracket	105	1	Filter
16	1	Motor Pivot Nut	61	1	Power Cord Set	106	1	Ground Wire
17	1	Motor Tension Bolt	62	1	Receptical	107	2	Long Screw
18	1	Reed Switch	63	2	Static Decal	108	1	Ground Nut
19	1	2" Incline Motor Bolt	64	1	Upright	109	1	Ferrite Box
20	1	Reed Switch Clip	65	1	Circuit Breaker	110	1	Filter Wire
21	1	Lift Frame	66	1	Audio Wire Nut	#	1	14" White Wire, 2F
22	1	Motor Star Washer	67	1	On/Off Switch	#	1	8" White Wire, 2F
23	1	Controller Bracket	68	1	Belly Pan	#	1	10" Blue Wire, 2F
24	10	3/4" Screw	69	1	Audio Wire	#	1	4" Blue Wire, 2F
25	1	Controller	70	2	Frame Pivot Bolt	#	1	4" Blue Wire, M/F
26	1	Choke	71	2	Base Endcap	#	1	8" Green Wire, F/R
27	1	Power Board	72	4	Isolator	#	1	4" Black Wire, 2F
28	1	Plastic Stand-Off	73	2	Belt Guide	#	1	4" Red Wire, M/F
29	1	Power Board Bracket	74	4	Belt Guide Screw	#	1	User's Manual
30	1	Key/Clip	75	4	Platform Screw	#	1	14" Blue Wire, 2F
31	1	Left Foam Grip	76	1	Foot Pad (Right)			
32	1	Latch Assembly	77	1	Walking Belt			
33	15	Small Screw	78	1	Front Roller/Pulley			
34	2	Handrail Extension	79	1	Foot Pad (Left)			
35	25	Screw	80	1	Walking Platform			
36	1	iFIT.com Wire	81	9	8" Cable Tie			
37	3	Small Screw	82	8	Electronic Screw			
38	1	Console Base	83	3	Tie Holder Clamp			
39	2	Upright Endcap	84	2	Releasable Tie			
40	1	Console Back	85	1	Pulse Wire			
41	1	Book Holder	86	1	Motor Pivot Sleeve			
42	1	Console	87	1	Rear Roller			
43	1	Right Foam Grip	88	1	Rear Foot (Right)			
44	8	Base Pad	89	1	Motor Controller Wire			
45	2	Platform Screw (Rear)	90	1	iFIT.com Jack			

These parts are not illustrated
 * Includes all parts shown in the box

REMOVE THIS EXPLODED DRAWING AND PART LIST FROM THE MANUAL

Save this EXPLODED DRAWING and PART LIST for future reference.

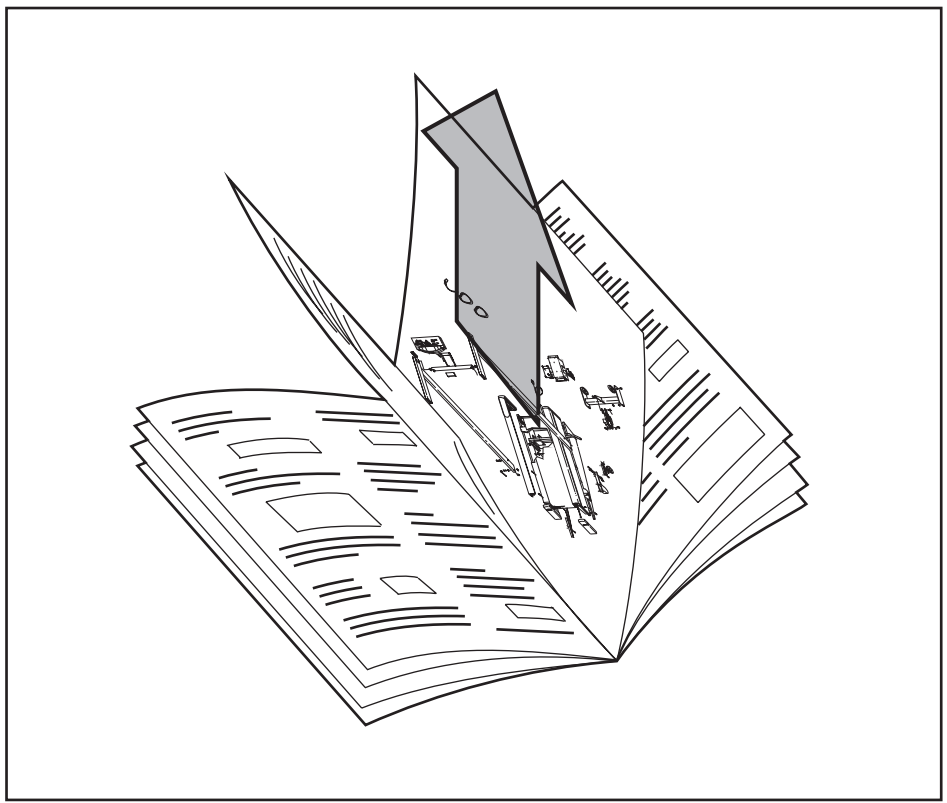

Note: Specifications are subject to change without notice. For information about ordering replacement parts, see the back cover of the User's Manual.

EXPLODED DRAWING—Model No. PETL61021

