



Maintenance and Service Guide

Compaq Evo N200 Series

Document Part Number: 233117-001

September 2001

This guide is a troubleshooting reference used for maintaining and servicing the notebook. It provides comprehensive information on identifying computer features, components, and spare parts, troubleshooting computer problems, and performing computer disassembly procedures.

© 2001 Compaq Computer Corporation

Compaq and the Compaq logo Registered in U. S. Patent and Trademark Office.
Evo is a trademark of Compaq Information Technologies Group, L.P.

Microsoft and Windows are trademarks of Microsoft Corporation.

Intel and Pentium are trademarks of Intel Corporation.

All other product names mentioned herein may be trademarks of their respective companies.

Compaq shall not be liable for technical or editorial errors or omissions contained herein. The information in this document is provided "as is" without warranty of any kind and is subject to change without notice. The warranties for Compaq products are set forth in the express limited warranty statements accompanying such products. Nothing herein should be construed as constituting an additional warranty.

Maintenance and Service Guide

First Edition (September 2001)

Document Part Number: 233117-001

Contents

1 Product Description

1.1 Features	1-2
1.2 Clearing a Password.	1-4
1.3 Power Management	1-5
1.4 Computer External Components	1-6
1.4 Design Overview	1-16

2 Troubleshooting

Using the PhoenixBIOS Setup Utility	2-1
Troubleshooting Flowcharts.	2-2
Initial Troubleshooting	2-3
2.2 No Power, Part 1	2-4
2.3 No Power, Part 2	2-5
2.4 No Power, Part 3	2-6
2.5 No Power, Part 4	2-7
2.6 No Video, Part 1	2-8
2.7 No Video, Part 2	2-9
2.8 Nonfunctioning Docking Station (if applicable).	2-10
2.9 No Operating System (OS) Loading	2-11
2.10 No OS Loading from Hard Drive, Part 1.	2-12
2.11 No OS Loading from Hard Drive, Part 2.	2-13
2.12 No OS Loading from Hard Drive, Part 3.	2-14
2.13 No OS Loading from Diskette Drive.	2-15
2.14 No OS Loading from CD- or DVD-ROM Drive	2-16
2.15 No Audio, Part 1	2-17
2.16 No Audio, Part 2	2-18

2.17 Nonfunctioning Device	2-19
2.18 Nonfunctioning Keyboard	2-20
2.19 Nonfunctioning Pointing Device	2-21
2.20 Network or Modem Connection Problems . . .	2-22

3 Illustrated Parts Catalog

3.1 Serial Number Location	3-1
3.2 Computer System Major Components	3-2
3.3 Miscellaneous Plastics Kit Components	3-6
3.4 Cable Kit Components	3-7
3.5 Miscellaneous Spare Parts	3-8

4 Removal and Replacement Preliminaries

4.1 Tools Required	4-1
4.2 Service Considerations	4-2
Plastic Parts	4-2
Cables and Connectors	4-2
4.3 Preventing Damage to Removable Drives	4-3
4.4 Preventing Electrostatic Damage	4-4
4.5 Packaging and Transporting Precautions	4-4
4.6 Workstation Precautions	4-5
4.7 Grounding Equipment and Methods	4-6

5 Removal and Replacement Procedures

5.1 Serial Number	5-2
5.2 Disassembly Sequence Chart	5-3
5.3 Preparing the Computer for Disassembly	5-4
5.4 Computer Feet	5-5
5.5 Modem/NIC	5-6
5.6 LED Cover	5-9
5.7 Microphone	5-10
5.8 Keyboard	5-11
5.9 LED Board	5-12
5.10 Display	5-15
5.11 Top Cover	5-18

5.12 RTC Battery	5-22
5.13 System Board	5-24
5.14 Charger Board	5-27
5.15 Modem/NIC Cable	5-29
5.16 Audio Cable	5-31

6 Specifications

A Connector Pin Assignments

B Power Cord Set Requirements

3-Conductor Power Cord Set	B-1
General Requirements	B-1
Country-Specific Requirements	B-2
Notes	B-3

C Screw Listing

Index

Product Description

The Compaq Evo N200 Series of Personal Computers offers advanced modularity, a 700-MHz Intel Pentium III processor with 64-bit architecture, industry-leading Accelerated Graphics Port (AGP) implementation, and extensive multimedia support. The computer provides desktop functionality and connectivity through the optional Mobile Expansion Unit (MEU).



All Evo N200 computer models have an SKU number of 243420-B21 and a config. code of KCJZ.



Figure 1-1. Compaq Evo N200

1.1 Features

The computer has the following features:

- Intel Pentium III 700-MHz processor, with 256-KB integrated cache
- ATI Mobility M1, 8-MB SDRAM
- 192 MB standard memory (64 MB integrated on system board, 128 MB in memory expansion compartment)
- Microsoft Windows 2000
- 10.4-inch, XGA, TFT (1024 × 768) display, with over 16.8 million colors
- TouchPad pointing device
- Mini PCI V.90 modem plus 10/100 NIC combination card
- Support for one Type II PC Card slot with support for both 32-bit CardBus and 16-bit PC Cards

- External AC adapter with power cord
- Support for a 6-cell Lithium ion (Li ion) primary battery pack in the battery bay and an optional external 4-cell Li ion
- 20-GB high-capacity hard drive
- Speaker
- Connectors for:
 - RJ-45 network
 - RJ-11 modem
 - External monitor
 - Mobile Expansion Unit (MEU)
 - Stereo speaker/headphone
 - Microphone
 - Universal serial bus (USB)
 - AC power

1.2 Clearing a Password

If the notebook you are servicing has an unknown password, follow these steps to clear the password. These steps also clear CMOS:

1. Prepare the computer for disassembly. Refer to Section 5.3, “Preparing the Computer for Disassembly,” for more information.
2. Remove the RTC battery (refer to Section 5.12, “RTC Battery”).
3. Wait approximately five minutes.
4. Replace the RTC battery and reassemble the computer.
5. Connect AC power to the computer. Do **not** reinsert any battery packs at this time.
6. Turn on the computer.

All passwords and all CMOS settings are clear.

1.3 Power Management

The computer comes with a collection of power management features that extends battery operating time and conserves power. The computer supports the following power management features:

- Standby
- Hibernation
- Setting customization by the user
- Hotkeys for setting level of performance
- Smart battery that provides an accurate battery power gauge
- Battery calibration
- Lid switch suspend/resume
- Power switch
- Standby button
- Advanced Configuration and Power Management (ACP) compliance

1.4 Computer External Components

The external components on the display and right side of the computer are shown in Figure 1-2 and described in Table 1-1.

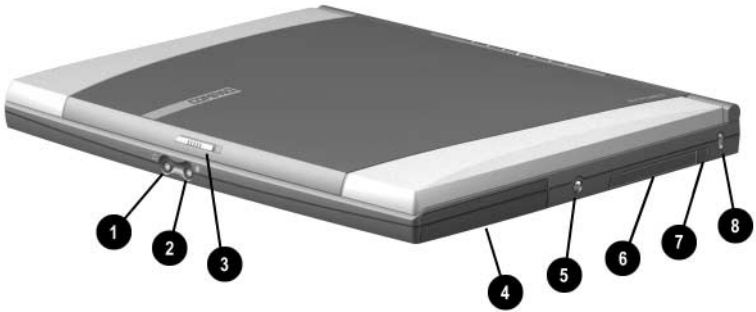

Figure 1-2. Front and Right Side Components

Table 1-1
Front and Right Side Components

Item	Component	Function
1	Stereo speaker/ headphone jack	Connects stereo speakers, headphones, headset, or television audio.
2	Microphone jack	Connects a single sound channel microphone.
3	Display release latch	Releases the display to open the computer.
4	Hard drive	Supports the removable primary hard drive.
5	Power jack	Connects any one of the following: <ul style="list-style-type: none">■ AC adapter■ Optional automobile power adapter/charger■ Optional aircraft power adapter
6	PC Card slot	Supports 32-bit (CardBus) and 16-bit PC Cards.
7	PC Card eject button	Ejects a PC Card from the PC Card slot.
8	Security cable slot	Attaches an optional security cable to the computer.

The computer rear panel and left side components are shown in Figure 1-3 and described in Table 1-2.

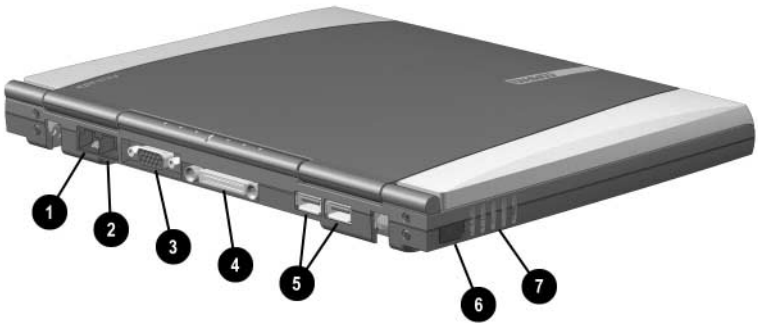



Figure 1-3. Rear Panel and Left Side Components

Table 1-2
Rear Panel and Left Side Components

Item	Component	Function
1	RJ-45 jack (network models only)	Connects the network cable.  A network cable is included with network models
2	RJ-11 jack (internal modem models only)	Connects the modem cable to an internal modem.  A modem cable is included with internal modem models.
3	External monitor connector	Connects an external monitor or overhead projector.
4	Docking connector	Connects the computer to an optional Mobile Expansion Unit.
5	USB connectors (2)	Connect USB devices.
6	Infrared port	Links another IrDA-compliant device for wireless communication.
7	Vent	Allows airflow to cool internal components.

The keyboard components are shown in Figure 1-4 and described in Table 1-3.

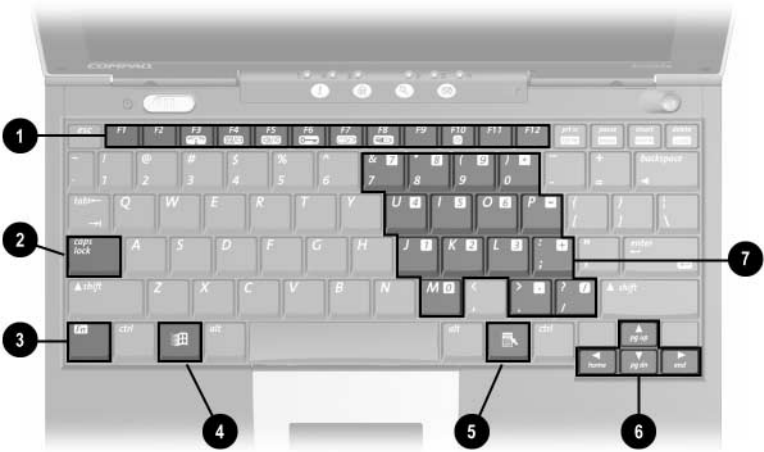

Figure 1-4. Keyboard Components

Table 1-3
Keyboard Components

Item	Component	Function
1	F1 through F12 function keys	Perform preset functions.
2	Caps lock key	Turns on the caps lock function.
3	Fn key	Used with hotkeys to perform preset hotkey functions.
4	Windows logo key	Displays Windows Start menu.
5	Windows application key	Displays a menu when using a Microsoft application. The menu is the same one that is displayed by pressing the right mouse button.
6	Cursor control keys	Move the cursor around the screen.
7	Embedded numeric keypad	Converts keys to numeric keypad.

The external components on the top of the computer are shown in Figure 1-5 and described in Table 1-4.



Figure 1-5. Top Components

**Table 1-4
Top Components**

Item	Component	Function
1	Power switch	Turns on the computer. To turn off the computer, use the operating system Shut Down command.
2	Easy Access buttons (4)	Provide quick access to the Internet.
3	Num lock light	On: Num lock is on and the embedded numeric keypad is enabled.

Table 1-4
Top Components (Continued)

Item	Component	Function
4	Caps lock light	On: Caps lock is on.
5	Scroll lock light	On: Scroll lock is on.
6	Battery light	On: A battery pack is charging. Blinking: A battery pack that is the only available power source has reached a low-battery condition.
7	Hard drive light	On: The primary hard drive is being accessed.
8	Power light	On: Power is turned on. Blinking: Computer is in Standby.  The power light also blinks if a battery pack that is the only available power source reaches a critical low-battery condition while Hibernation is disabled.
9	Microphone	Inputs single-channel sound to the computer; can be used whether the computer is open or closed.
10	Standby button	<ul style="list-style-type: none"> ■ Turns on the computer if it is off. ■ Initiates and exits Standby. ■ When pressed with the Fn key, initiates Hibernation.
11	TouchPad	Moves the mouse cursor, selects, and activates.
12	Left TouchPad button	Functions like the left mouse button on an external mouse.
13	Right TouchPad button	Functions like the right mouse button on an external mouse.

The external components on the bottom of the computer are shown in Figure 1-6 and described in Table 1-5.

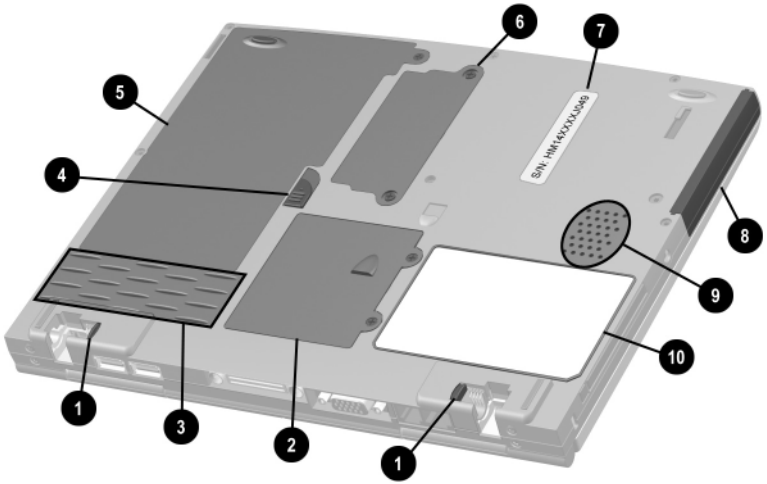

Figure 1-6. Bottom Components

**Table 1-5
Bottom Components**

Item	Component	Function
1	External battery release latches (2)	Release the external battery pack.
2	Mini PCI compartment cover	Contains the mini PCI modem or network interface card.
3	Vents	Provides airflow to cool internal components.
4	Primary battery release latch	Releases the primary battery pack from the battery bay.
5	Battery bay	Holds the primary battery pack.
6	Memory expansion compartment cover	Covers the memory expansion compartment that contains one memory expansion slot for a memory expansion board.
7	Serial number	Identifies the computer; needed when you call Compaq customer support.
8	Hard drive	Supports the removable primary hard drive. One screw secures the hard drive to the computer.
9	Speaker	Produces sound.
10	Certificate of Authenticity label	Contains the Product Key, which may need to be entered before using some Windows operating systems.

1.4 Design Overview

This section presents a design overview of key parts and features of the computer. Refer to Chapter 3, “Illustrated Parts Catalog,” to identify replacement parts, and Chapter 5, “Removal and Replacement Procedures,” for disassembly steps.

The system board provides the following device connections:

- Memory expansion board
- Hard drive
- Display
- Keyboard
- TouchPad
- Audio
- Intel Pentium III processor
- PC Card
- Modem
- Network interface card



CAUTION: To properly ventilate the computer, allow at least a 3-inch (7.6 cm) clearance on the right side of the computer.

Troubleshooting



WARNING: Only authorized technicians trained by Compaq should repair this equipment. All troubleshooting and repair procedures are detailed to allow only subassembly/module level repair. Because of the complexity of the individual boards and subassemblies, no one should attempt to make repairs at the component level or to make modifications to any printed wiring board. Improper repairs can create a safety hazard. Any indication of component replacement or printed wiring board modification may void any warranty or exchange allowances.

Utilities that are preinstalled on the computer include:

- **PhoenixBIOS Setup Utility**—Allows you to modify or restore factory default settings and configure the system BIOS to diagnose and solve minor problems.
- **Power Management**—Allows you to reduce your computer power consumption.
- **Security**—Allows you to set or remove your power-on password.

Using the PhoenixBIOS Setup Utility

The PhoenixBIOS Setup Utility (PSU) is built into the system. You can configure the system BIOS and modify or restore factory default settings, such as date and time, types of disk drives, power management, and password settings. To run PSU, press the **F10** key during system startup. When the main screen displays, use the keyboard and arrow keys to move around the menus and make selections.

Troubleshooting Flowcharts

Table 2-1
Troubleshooting Flowcharts Overview

Section	Description
2.1	Initial troubleshooting
2.2	No power, part 1
2.3	No power, part 2
2.4	No power, part 3
2.5	No power, part 4
2.6	No video, part 1
2.7	No video, part 2
2.8	Nonfunctioning docking station
2.9	No operating system (OS) loading
2.10	No OS loading from hard drive, part 1
2.11	No OS loading from hard drive, part 2
2.12	No OS loading from hard drive, part 3
2.13	No OS loading from diskette drive
2.14	No OS loading from CD- or DVD-ROM drive
2.15	No audio, part 1
2.16	No audio, part 2
2.17	Nonfunctioning device
2.18	Nonfunctioning keyboard
2.19	Nonfunctioning pointing device
2.20	No network or modem connection

Initial Troubleshooting

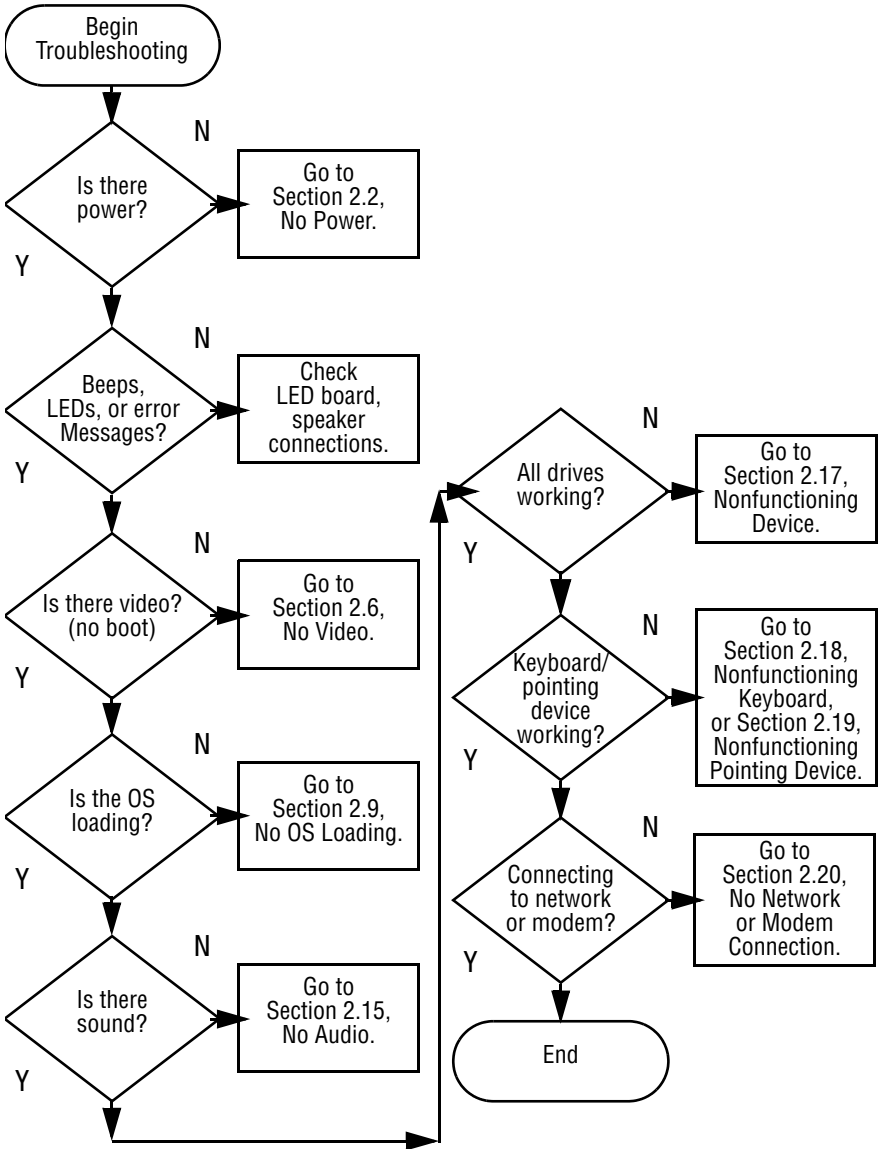

2.2 No Power, Part 1

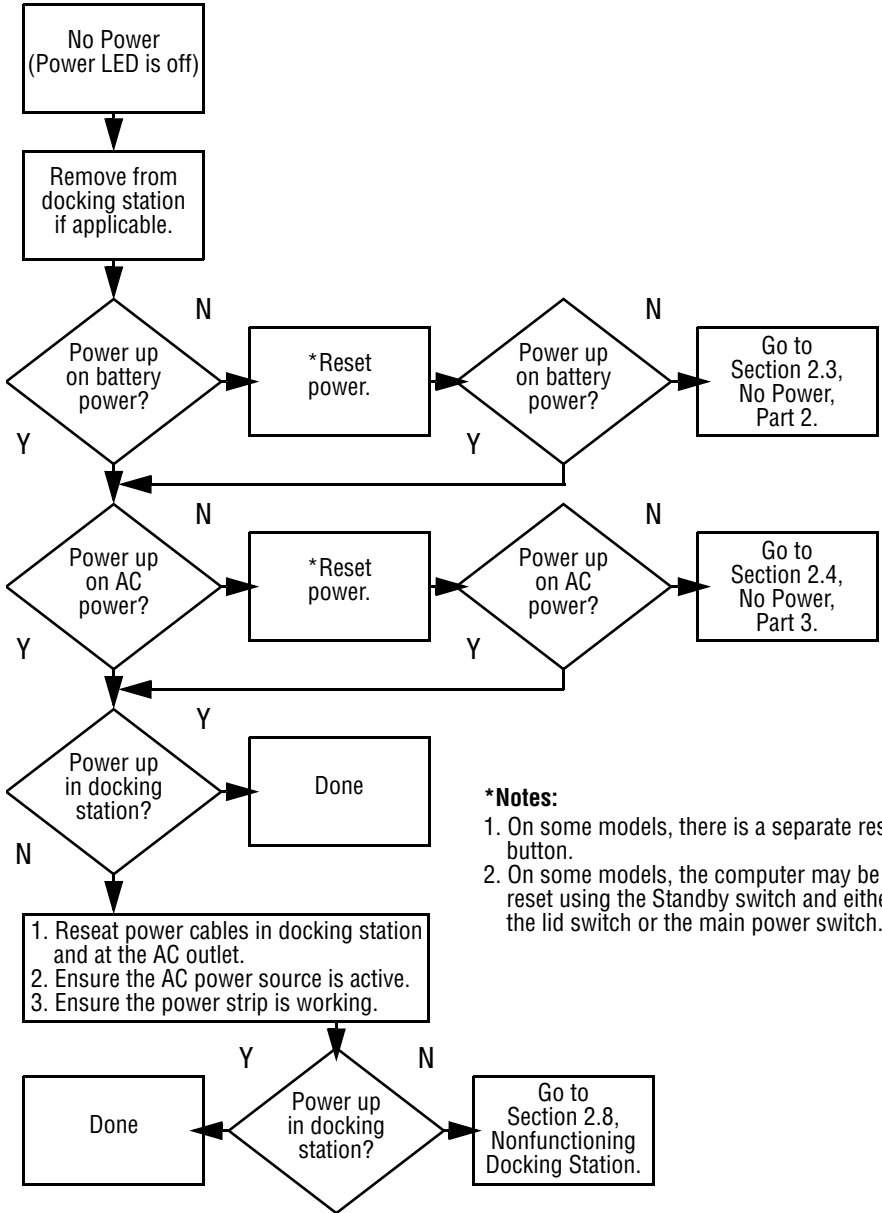

***Notes:**

1. On some models, there is a separate reset button.
2. On some models, the computer may be reset using the Standby switch and either the lid switch or the main power switch.

2.3 No Power, Part 2

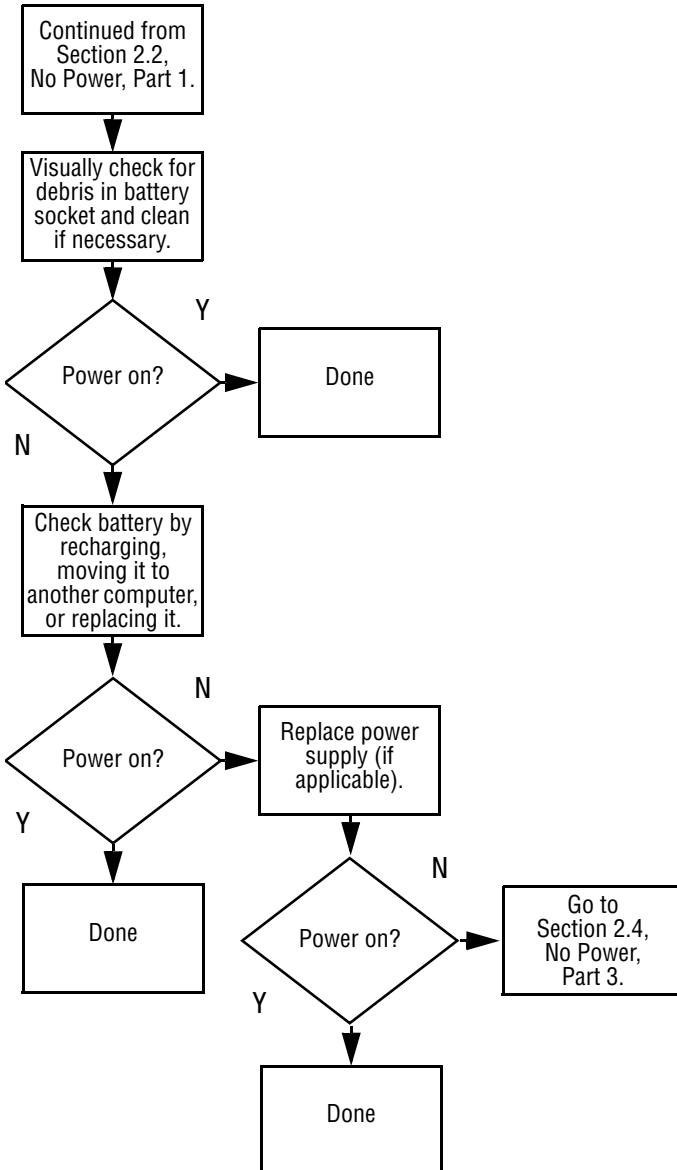

2.4 No Power, Part 3

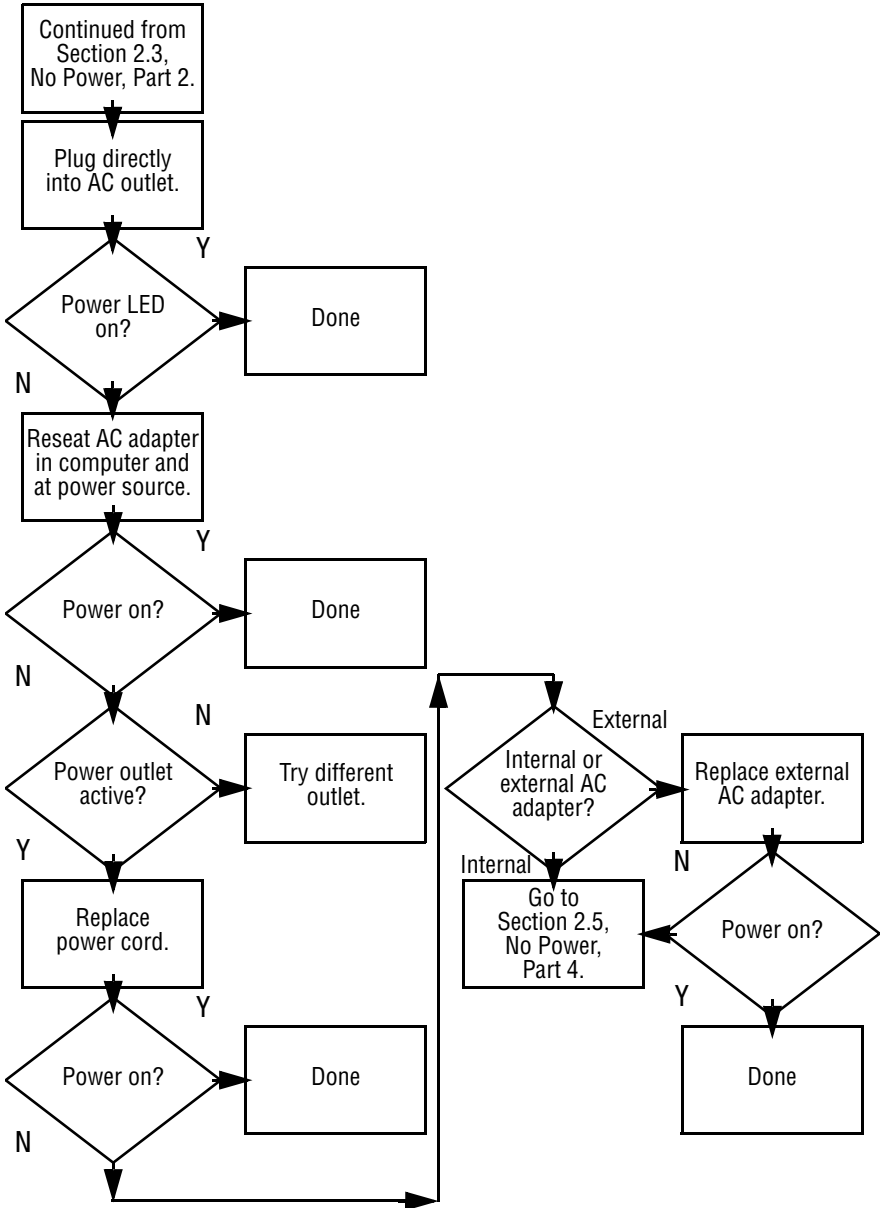

2.5 No Power, Part 4

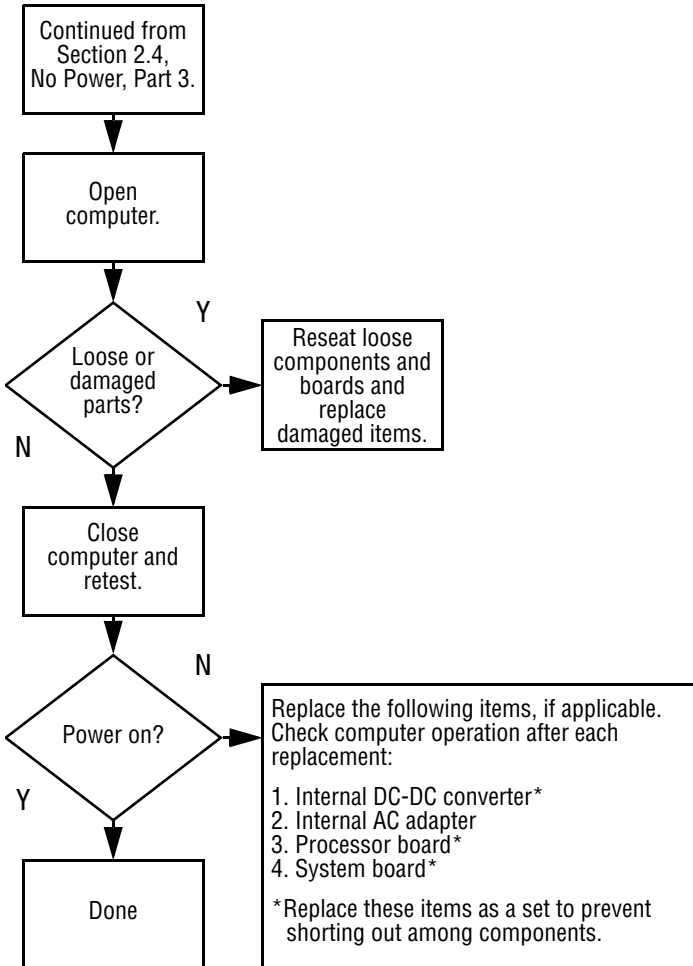

2.6 No Video, Part 1

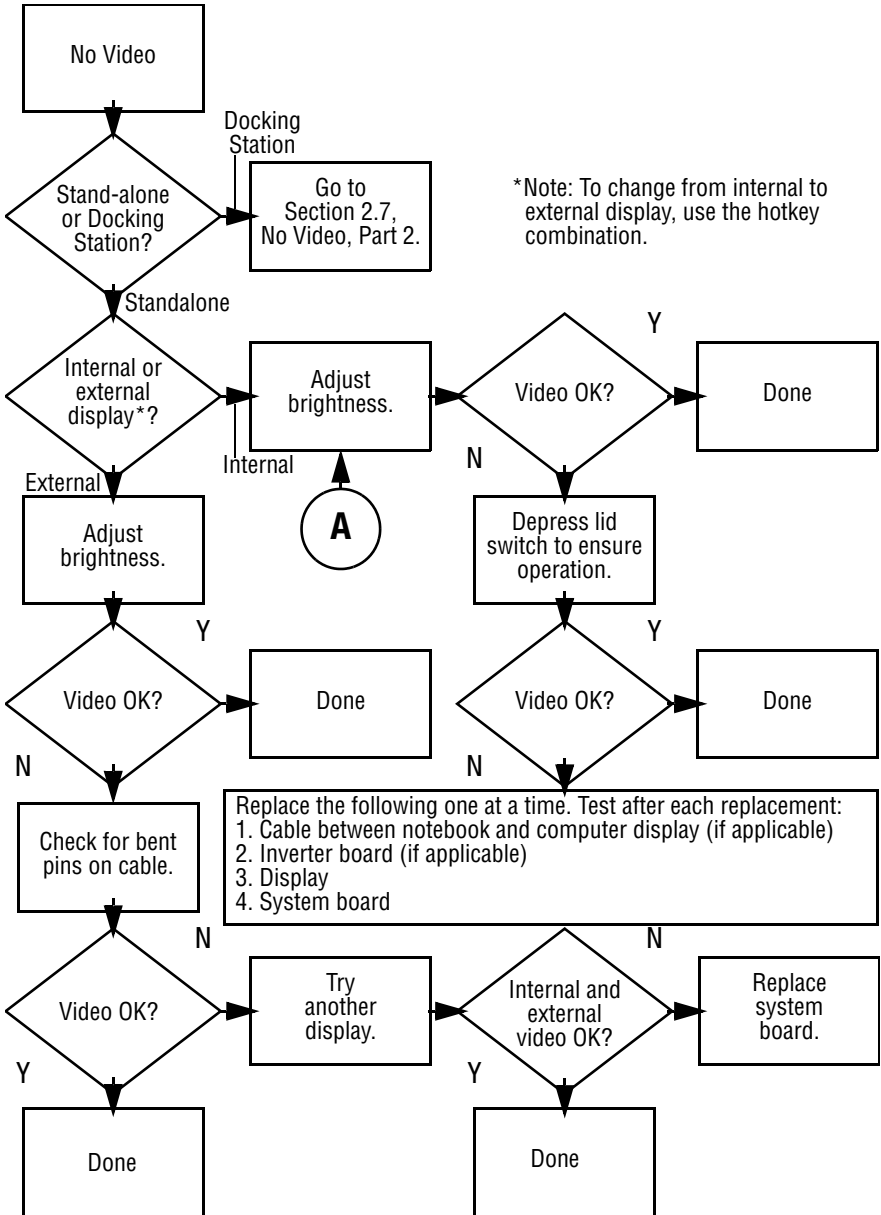

2.7 No Video, Part 2

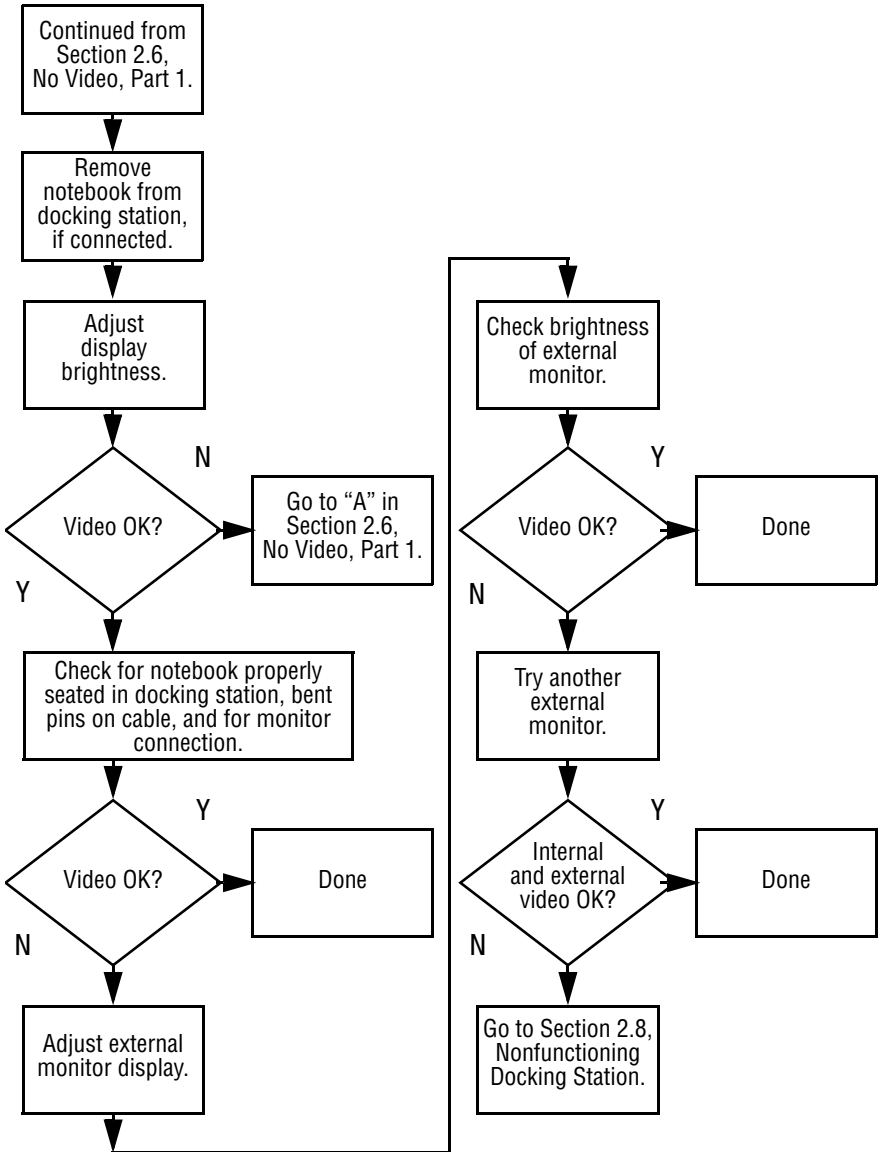

2.8 Nonfunctioning Docking Station (if applicable)

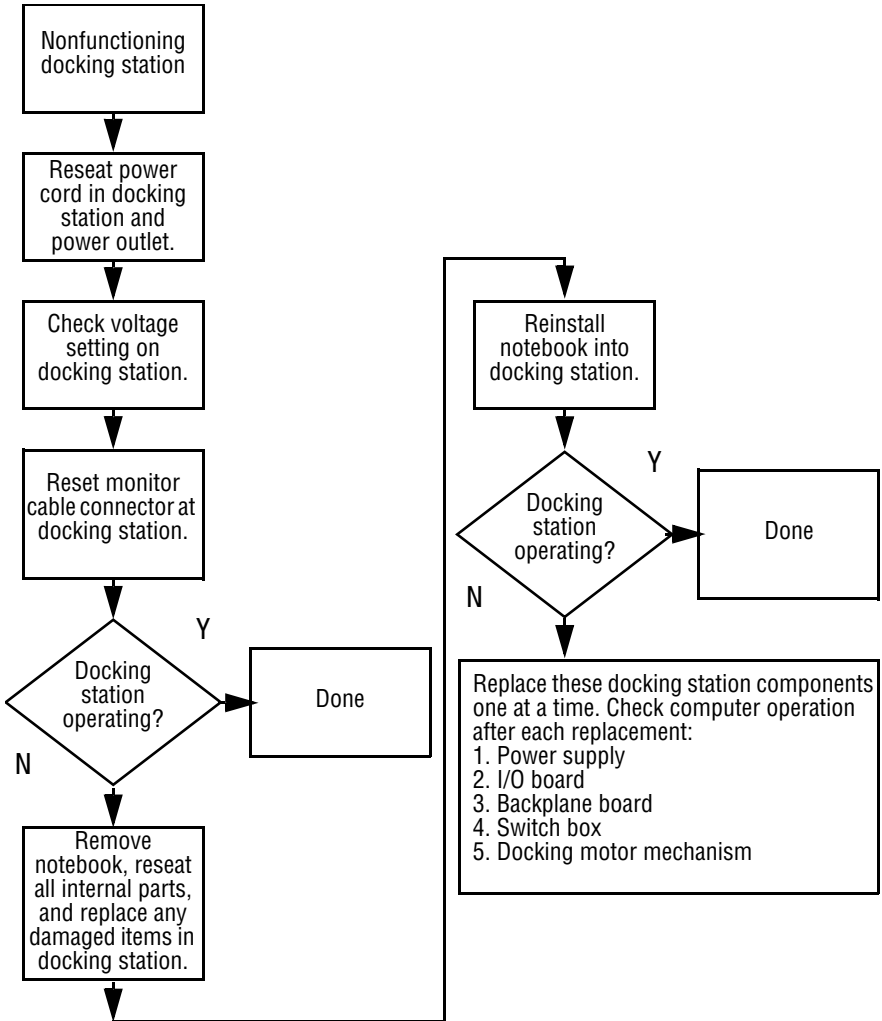

2.9 No Operating System (OS) Loading

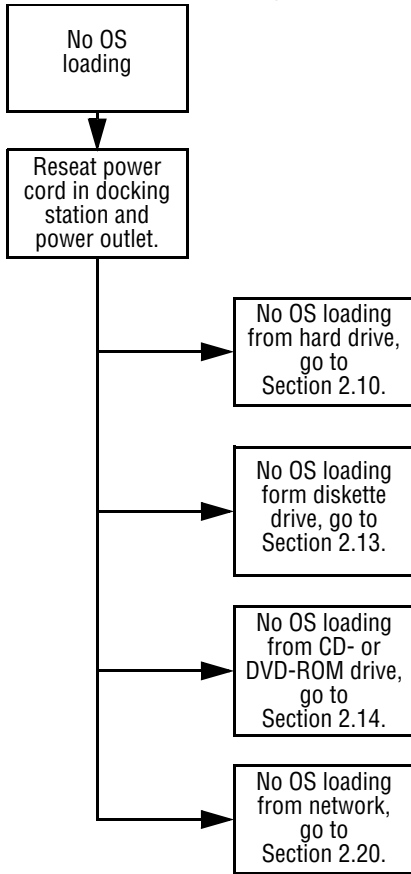

*Note: Before beginning, always check cable connections, cable ends, and drives for bent or damaged pins.

2.10 No OS Loading from Hard Drive, Part 1

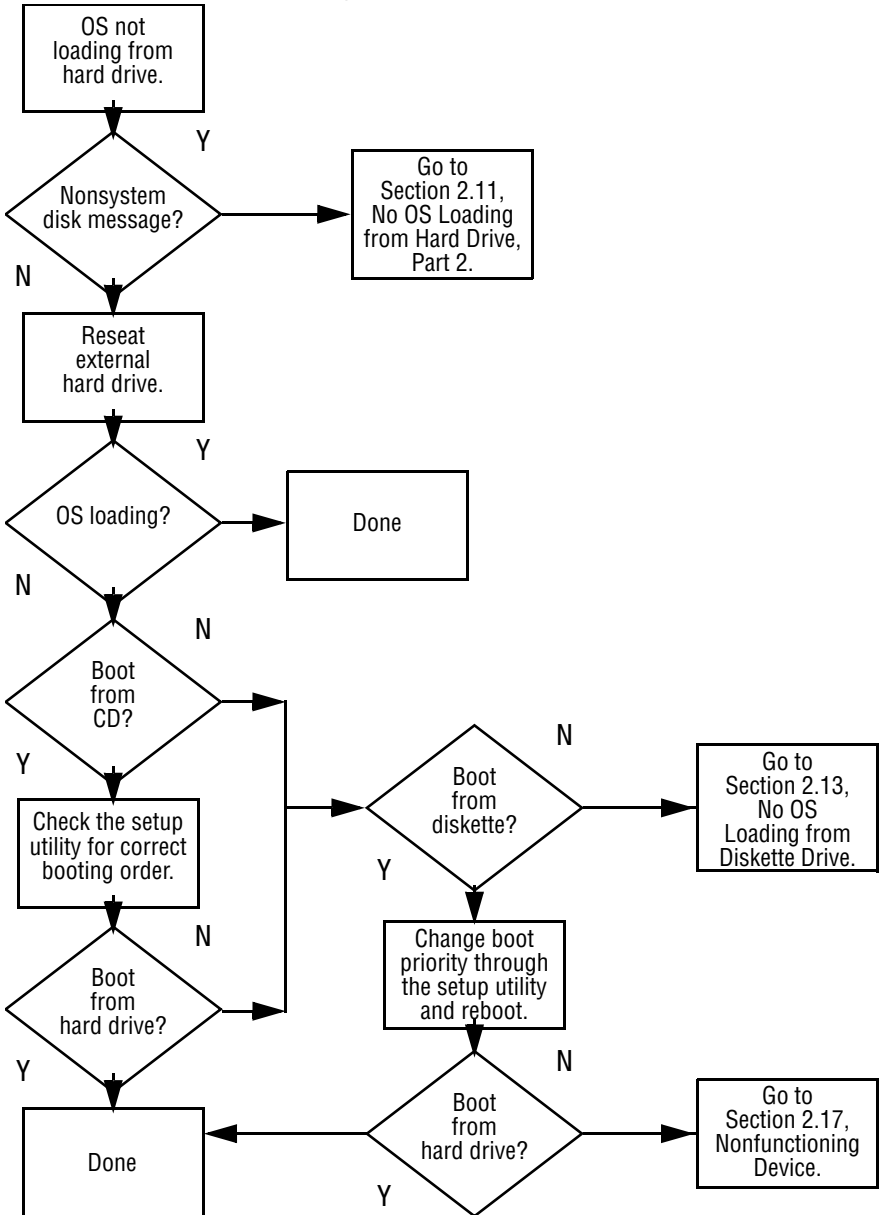

2.11 No OS Loading from Hard Drive, Part 2

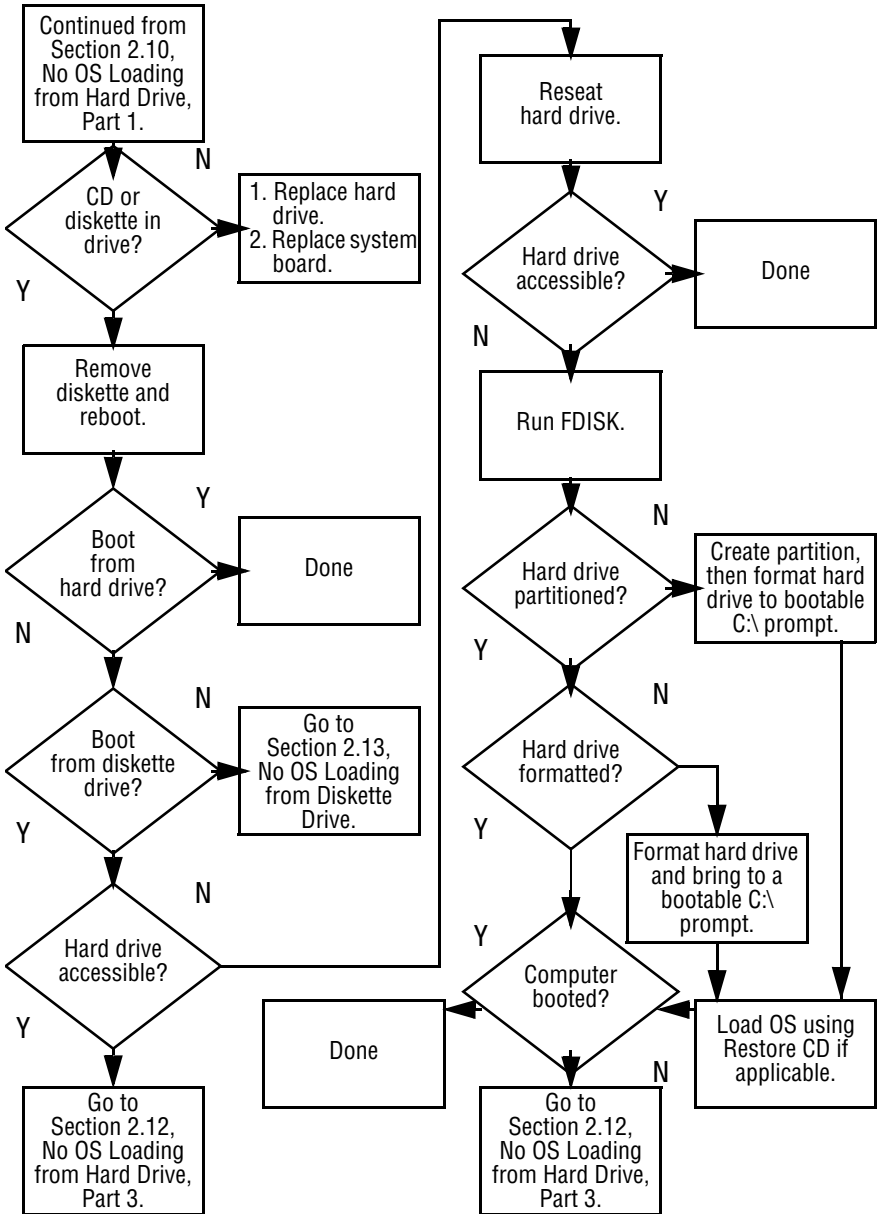

2.12 No OS Loading from Hard Drive, Part 3

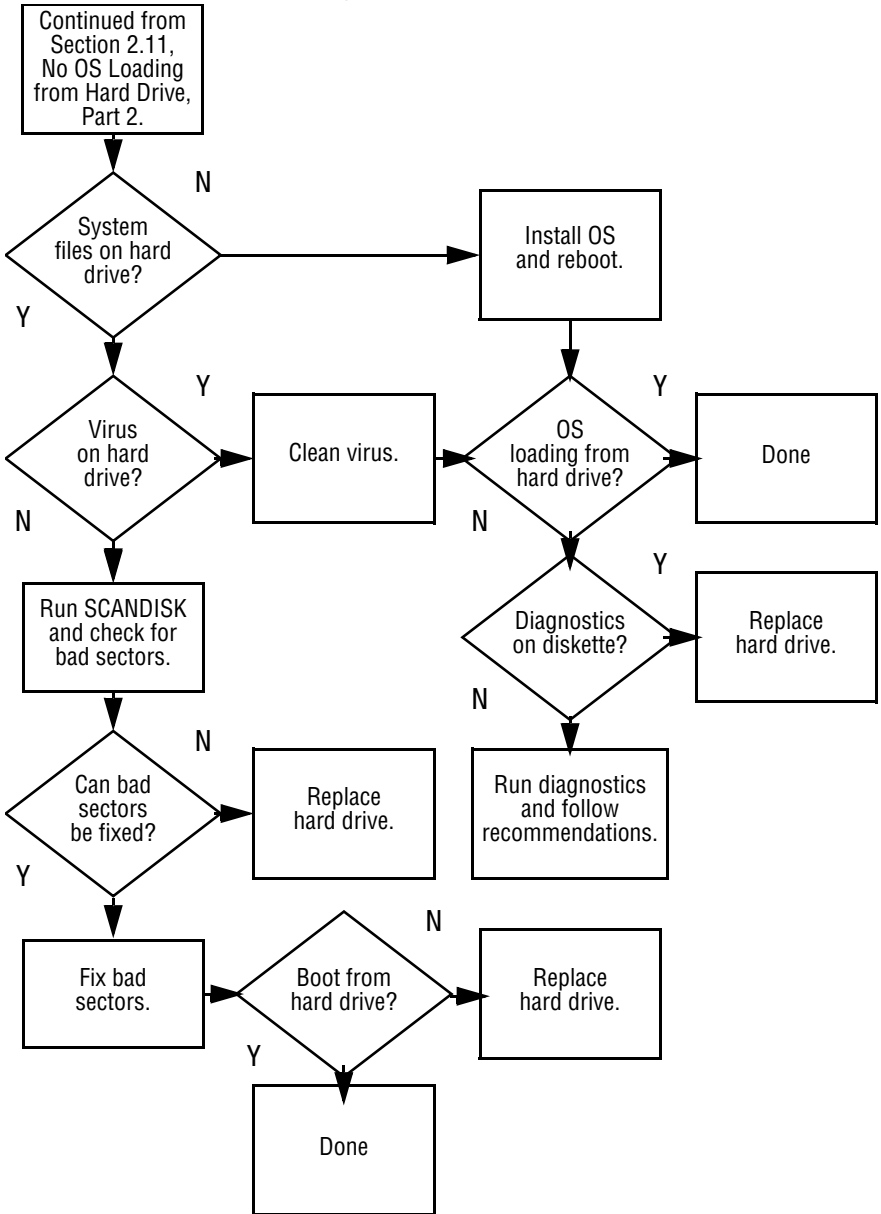

2.13 No OS Loading from Diskette Drive

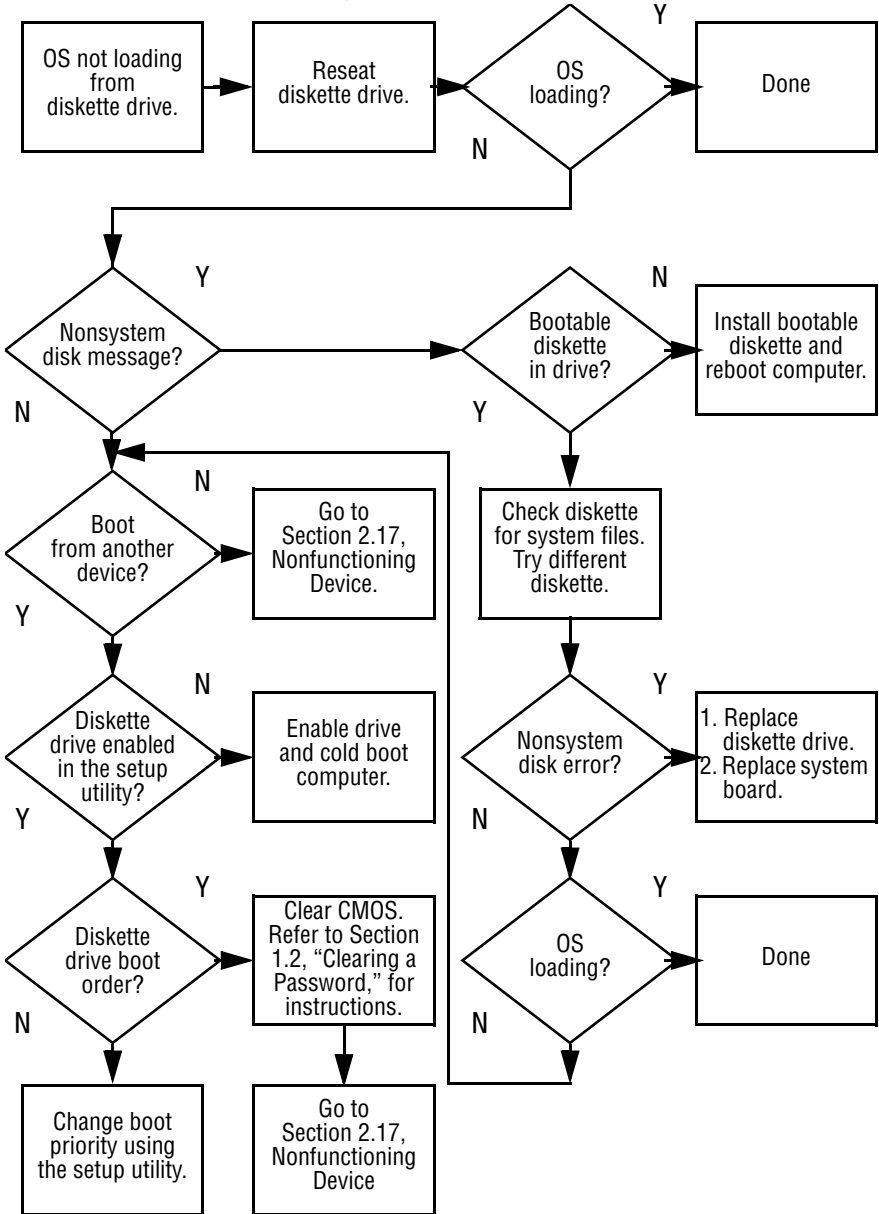

2.14 No OS Loading from CD- or DVD-ROM Drive

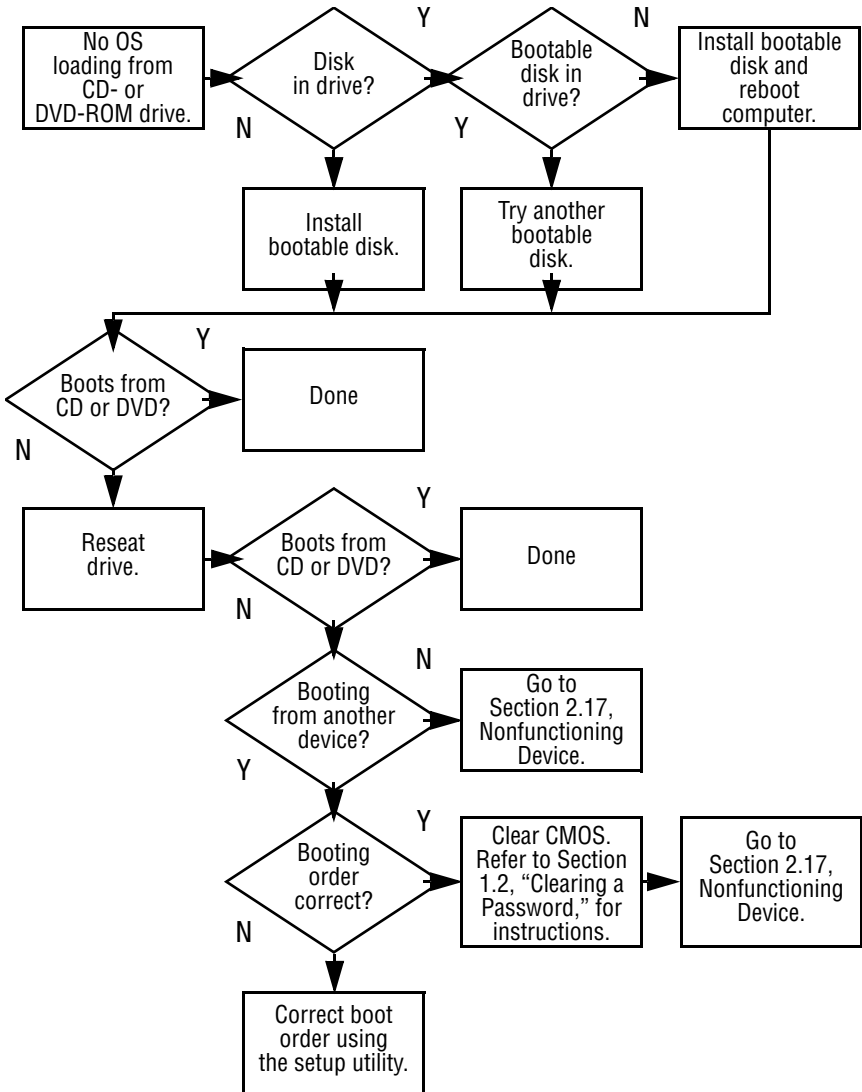

2.15 No Audio, Part 1

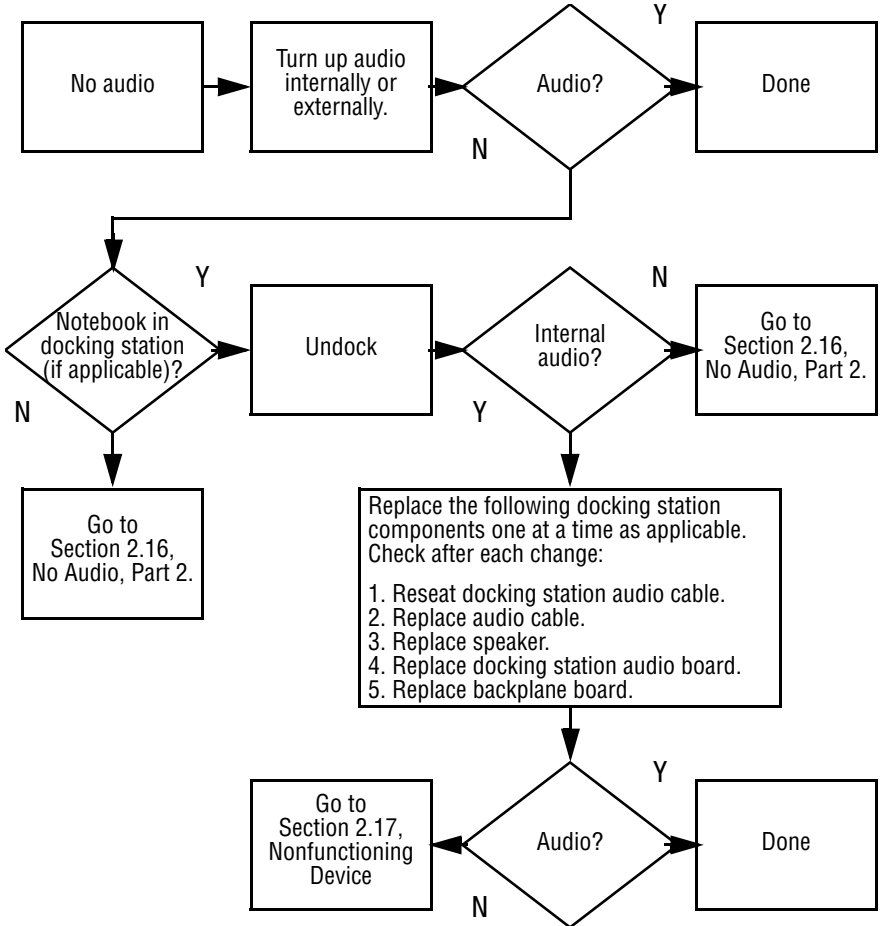

2.16 No Audio, Part 2

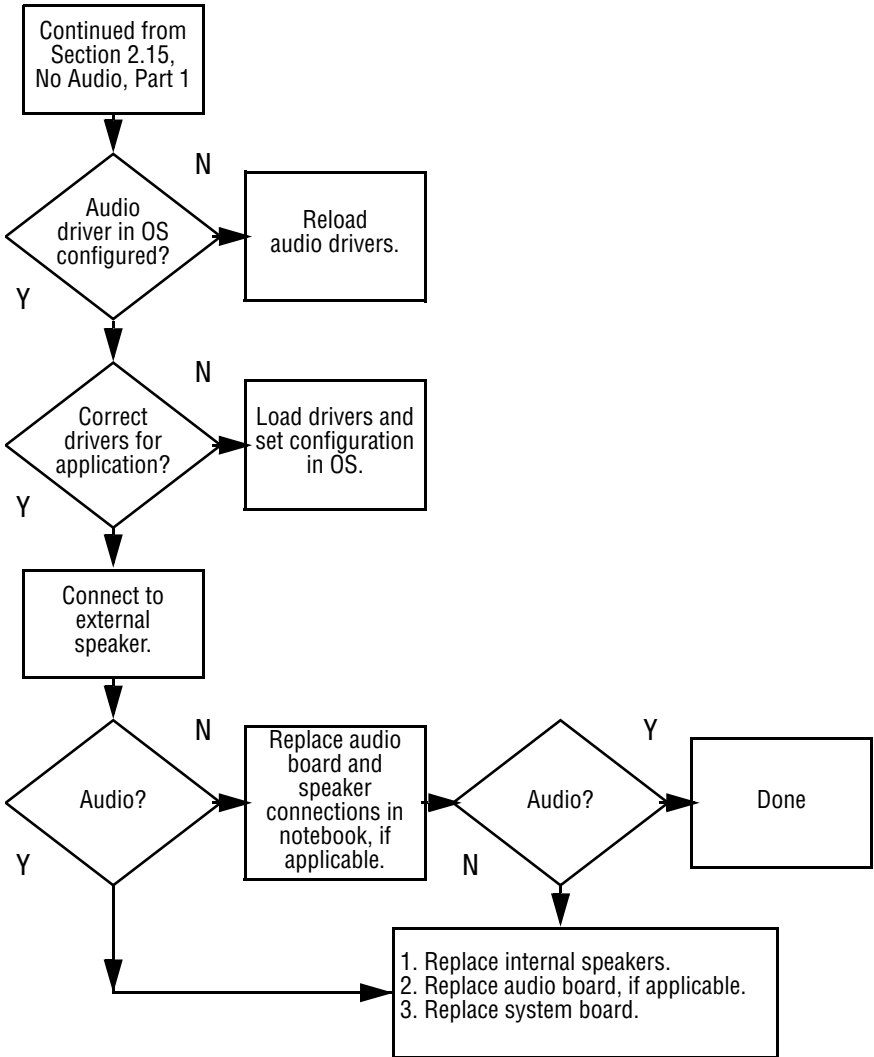

2.17 Nonfunctioning Device

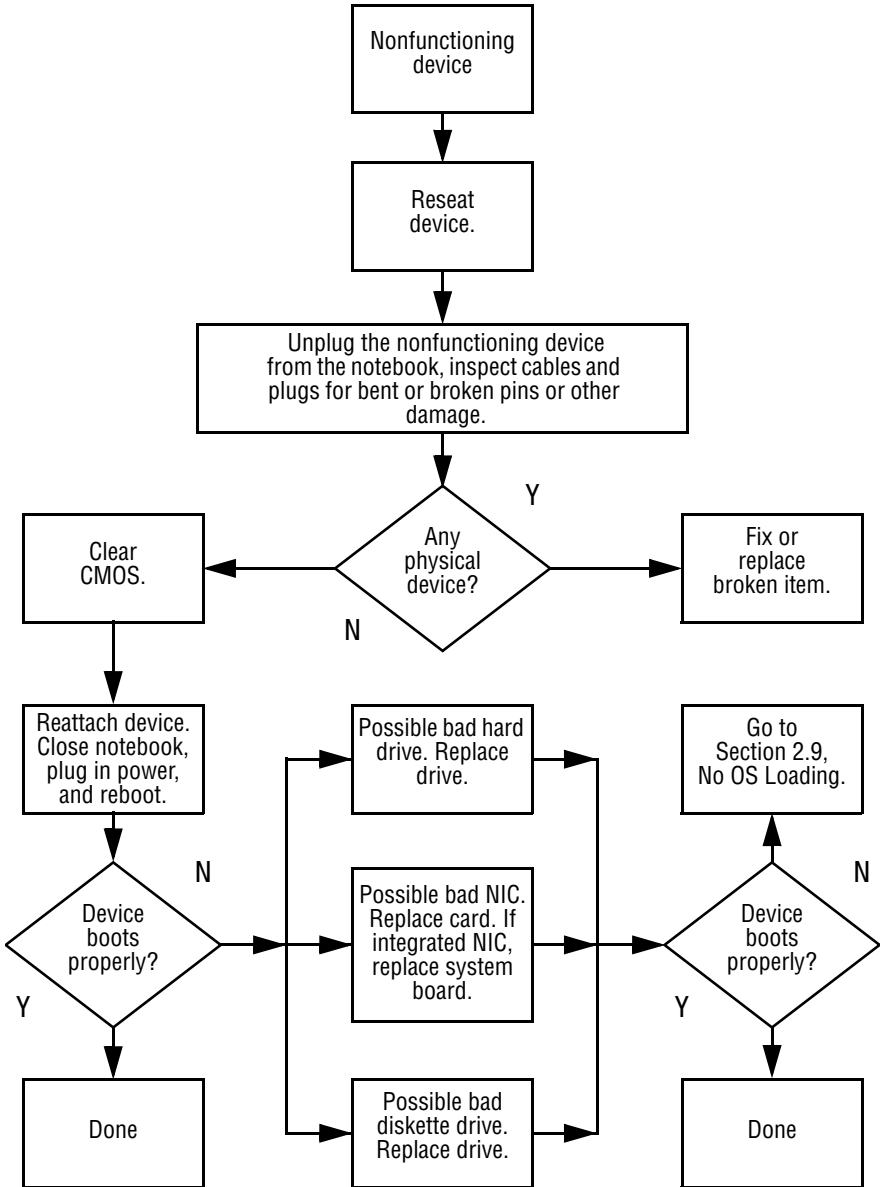

2.18 Nonfunctioning Keyboard

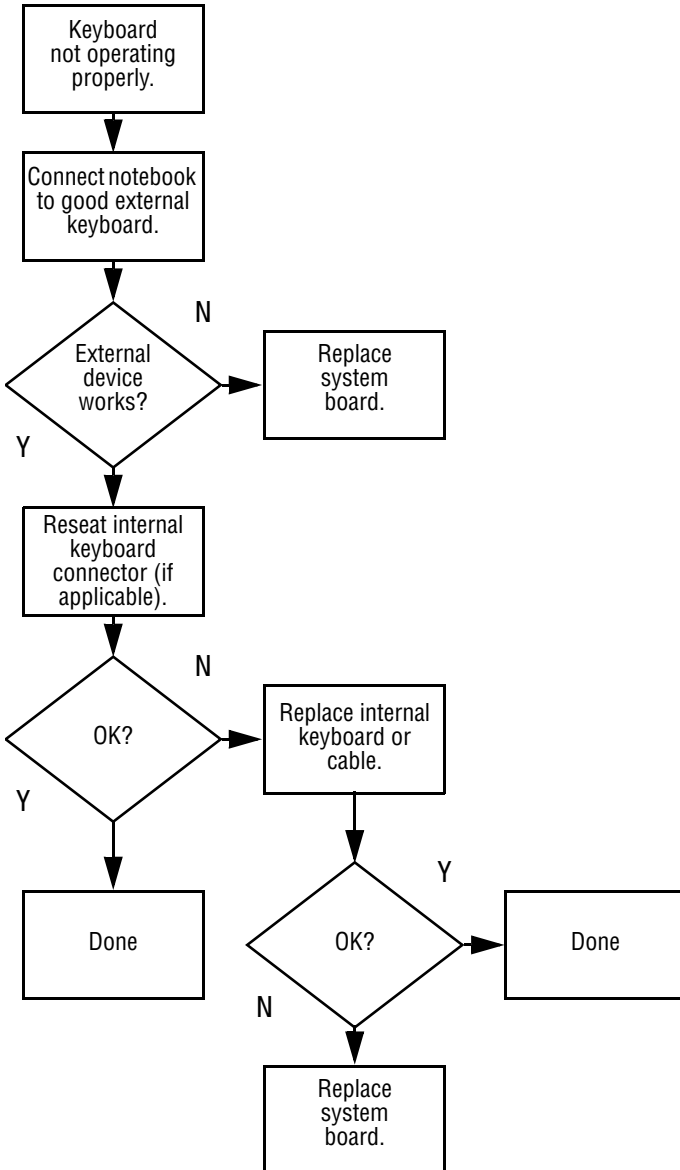

2.19 Nonfunctioning Pointing Device

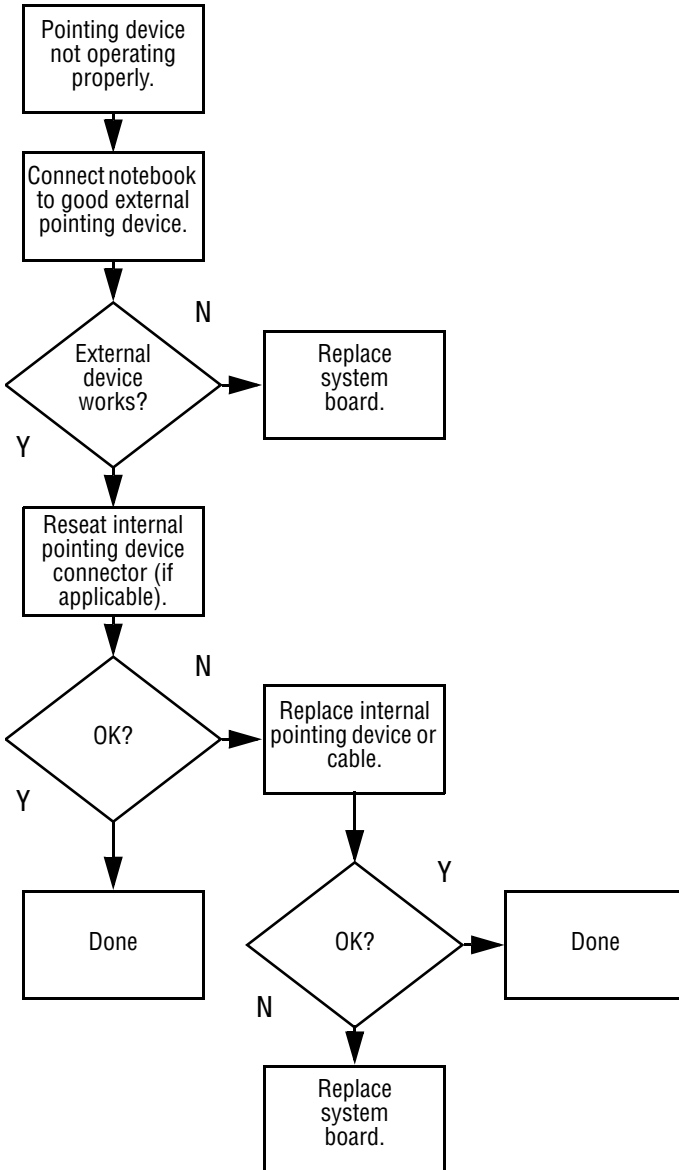

2.20 Network or Modem Connection Problems

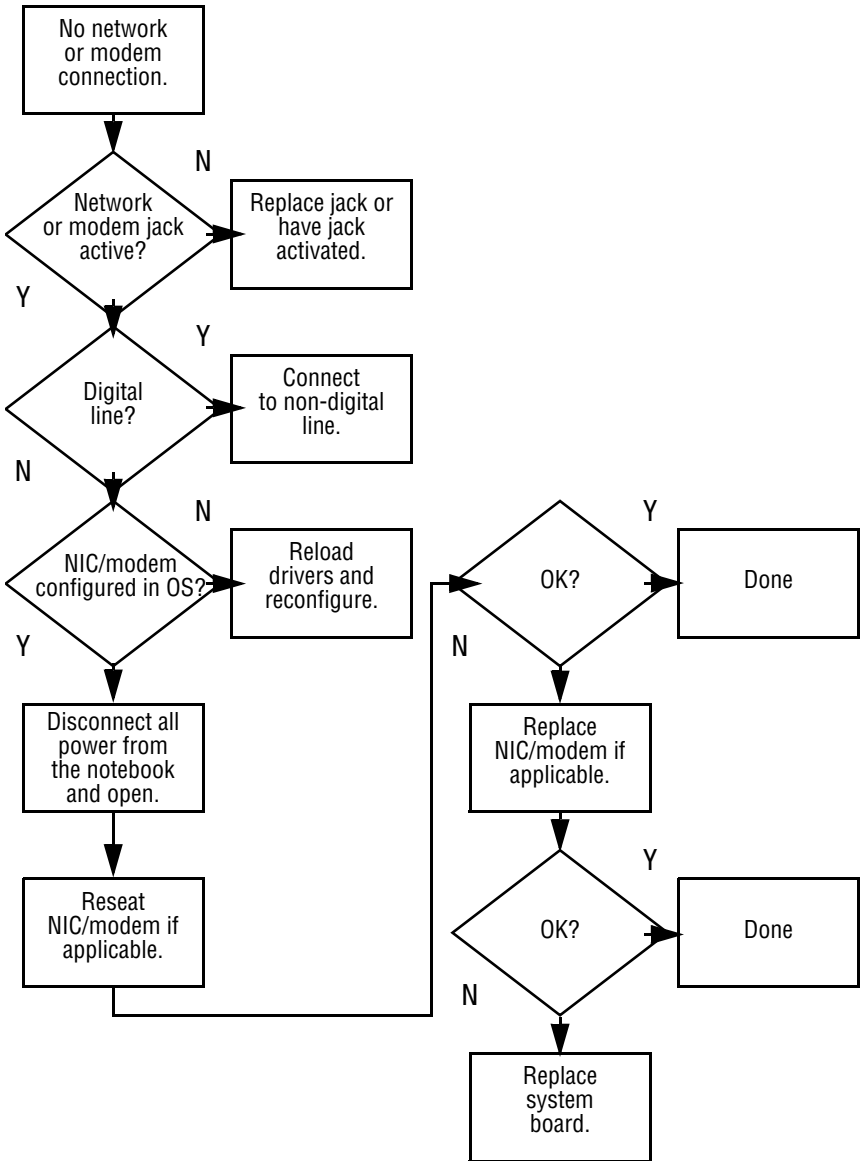

Illustrated Parts Catalog

This chapter provides an illustrated parts breakdown and a reference for spare part numbers and option part numbers.

3.1 Serial Number Location

When ordering parts or requesting information, provide the computer serial number and model number located on the bottom of the computer as indicated in Figure 3-1.

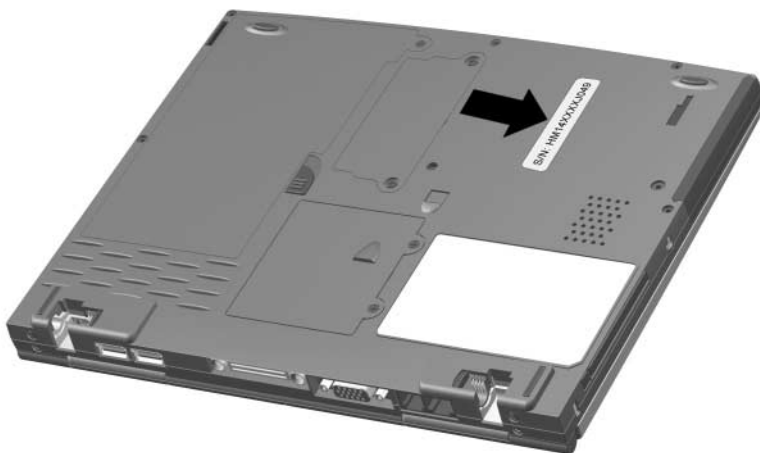

Figure 3-1. Serial Number Location

3.2 Computer System Major Components

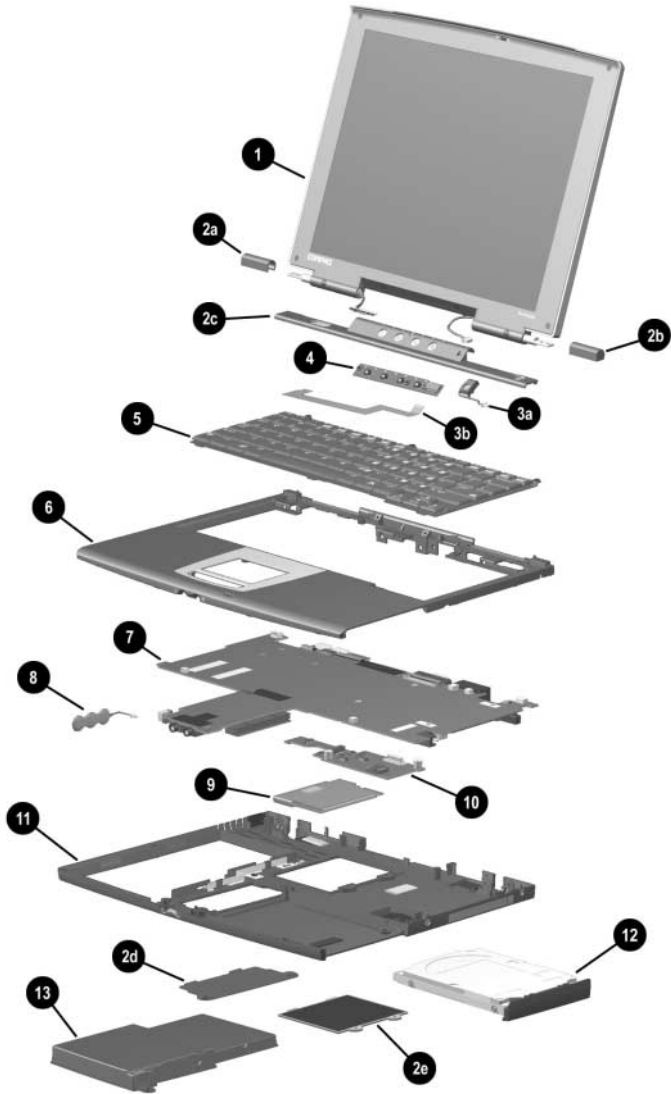
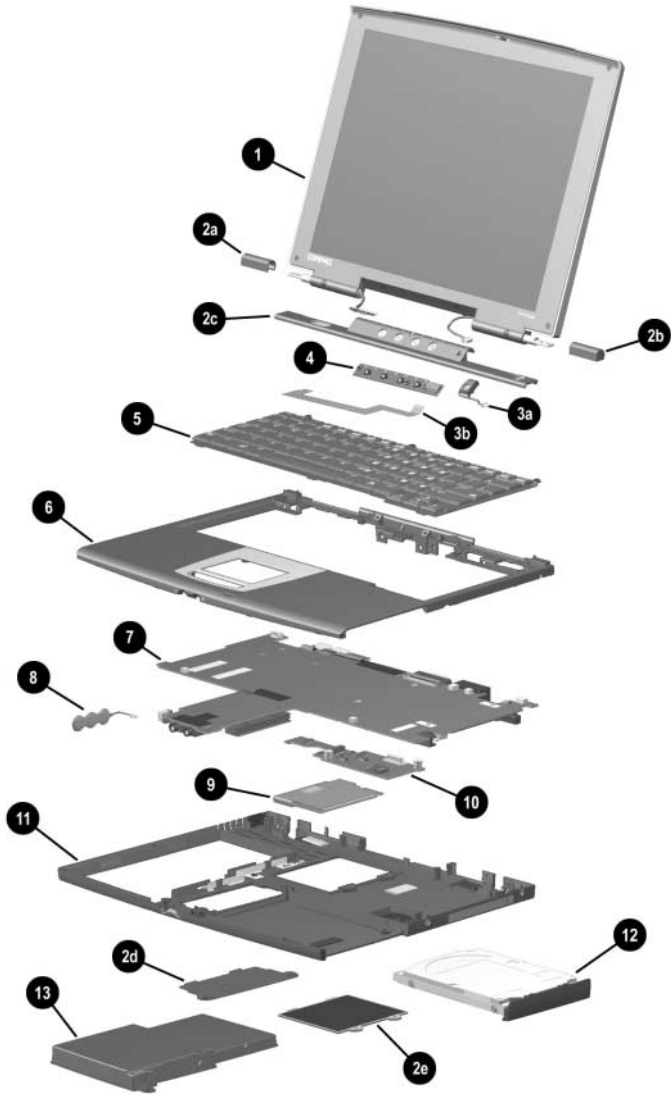

Figure 3-2. Computer System Major Components

**Table 3-1
Computer System Major Components**

Item	Description	Spare Part Number
1	10.4-inch XGA TFT Display	251633-001
	Miscellaneous Plastics Kit	251638-001
2a	Left hinge cover	Not illustrated
2b	Right hinge cover	■ Computer feet (4)
2c	LED cover	■ PC Card slot weight saver
2d	Memory expansion compartment cover	■ External battery slot spacers
2e	Mini PCI compartment cover	
	Cable Kit	251639-001
3a	Microphone	Not illustrated
3b	LED board cable	■ Modem/NIC cable ■ Audio cable ■ TouchPad cable
4	LED board	251631-001
5	Keyboards	
	Belgian	246339-181
	Brazilian	246339-201
	Czech	246339-221
	Danish	246339-081
	French	246339-051
	French Canadian	246339-121
	German	246339-041
	Hebrew	246339-BB1
	Hungarian	246339-211
	International	246339-002
	Italian	246339-061
	Japanese	246339-291
	Korean	246339-AD1
	Latin American	
	Spanish	246339-161
	Norwegian	246339-091
	Portuguese	246339-131
	Russian	246339-251
	Spanish	246339-071
	Swedish	246339-101
	Swiss	246339-111
	Taiwanese	246339-AB1
	Turkish	246339-141
	U.K. English	246339-031
	U.S. English	246339-001



Computer System Major Components (continued)

Table 3-1
Computer System Major Components (Continued)

Item	Description	Spare Part Number
6	Top Cover (includes TouchPad)	251643-001
7	System board with 700-MHz Intel Pentium III processor and 64 MB SDRAM 128-MB memory expansion board (shipped on system board; not illustrated)	251642-001 254086-001
8	RTC battery	252443-001
9	Combination modem/network interface card (NIC)	233558-001
10	Charger board	251640-001
11	Base enclosure (includes speaker and left and right external battery terminals and cables)	251634-001
12	Hard drives	
	20-GB hard drive	251635-001
	Optional 30-GB hard drive	251636-001
13	Battery packs	
	6-cell Lithium ion primary battery pack	240284-001
	Optional 4-cell Lithium ion external battery pack	240285-001

3.3 Miscellaneous Plastics Kit Components

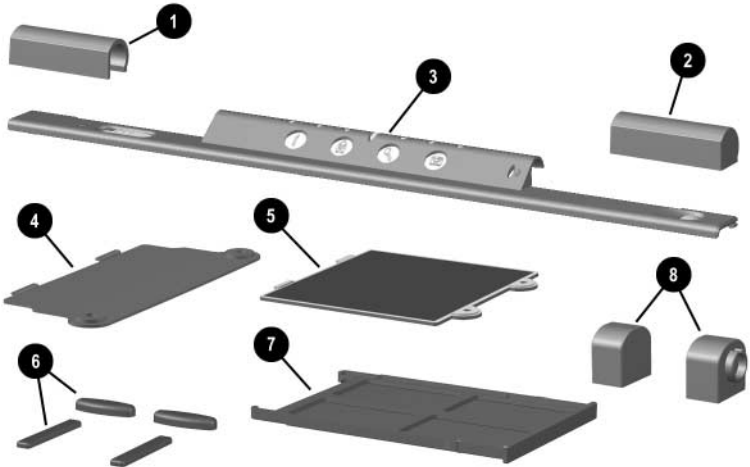

Figure 3-3. Miscellaneous Plastics Kit Components

**Table 3-2
Miscellaneous Plastics Kit Components
Spare Part Number 251638-001**

Item	Description	Item	Description
1	Left hinge cover (2)	5	Mini PCI compartment cover
2	Right hinge cover (2)	6	Computer feet (4)
3	LED cover	7	PC Card weight saver
4	Memory expansion compartment cover	8	External battery slot spacers (2)

3.4 Cable Kit Components

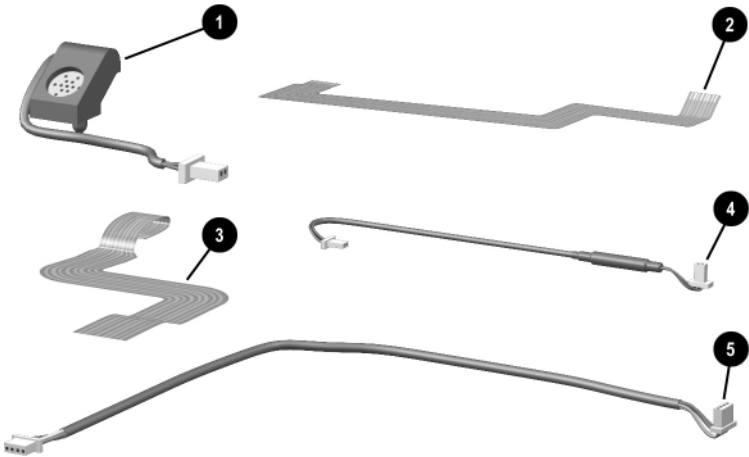

Figure 3-4. Cable Kit Components

**Table 3-3
Cable Kit Components
Spare Part Number 251639-001**

Item	Description
1	Microphone
2	LED board cable
3	TouchPad cable
4	Modem/NIC cable
5	Audio cable

3.5 Miscellaneous Spare Parts

**Table 3-4
Miscellaneous Spare Parts (not illustrated)**

Description	Spare Part Number
Power cord, black, 6 feet	
Australian	246959-011
Danish	246959-081
European/Middle Eastern/African	246959-021
Italian	246959-061
Japanese	197233-001
Korean	246959-AD1
People's Republic of China	234961-AA1
Swiss	246959-AG1
U.K. English	246959-031
U.S. English	246959-001
External AC adapters	163444-001 163444-291
Battery charger	153991-001
Screw kit (includes the following screws, screwlocks, and bushing guides; refer to Appendix C, "Screw Listing," for more information on screw specifications and usage)	251641-001
❖ Phillips P0 M2 × 10 screw	
❖ Phillips P0 M2 × 4 screw	
❖ Phillips P0 M1.5 × 6 screw	
❖ Torx T8 M2.5 × 5 screw	
❖ Torx T8 M2 × 15 screw	
❖ Torx T8 M2 × 8 screw	
❖ Torx T8 M2 × 5 screw	
❖ Torx T8 M2 × 4 screw	
❖ 5.0 mm × 9.5 screwlock	
❖ 9/64" hex wrench bushing guide	
RJ-45 Lan Cable	258048-001
RJ-11 LAN Cable	198220-001

Table 3-4
Miscellaneous Spare Parts (not illustrated) (Continued)

Description	Spare Part Number		
Logo Kit	251637-001		
Mobile Expansion Unit	248871-001		
The following options are for use only with the Mobile Expansion Unit:			
Hard drive adapter	155532-001		
8X DVD-ROM drive	173949-001		
4X DVD-ROM drive	102266-001		
24X CD-ROM drive	315082-002		
CD-RW drive	153992-001		
Modems			
PC Card modem	233564-001		
Modem adapters			
Czech	234963-221	Hungarian	234963-211
Dutch	316920-331	Norwegian	234963-091
German	236432-041	Swiss	198294-111
German/Polish	257942-001		
Modem cable adapters			
Australian	304398-011	Dutch	304398-331
Belgian	304398-181	French	304398-051
RJ-11 P55 adapters			
Danish	316904-081	Italian	316904-061
Finnish	316904-351	Swedish	316904-101
RJ-11 PTT adapter (used in the United Kingdom and Australia)			158593-031

Removal and Replacement Preliminaries

This chapter provides essential information for proper and safe removal and replacement service.

4.1 Tools Required

You will need the following tools to complete the removal and replacement procedures:

- Magnetic screwdriver
- Torx T8 screwdriver
- Phillips P0 screwdriver
- 5.0 mm socket (used on the screwlocks on each side of the external monitor connector)
- 9/64" hex wrench (used on the bushing guides on each side of the docking connector)
- Tool kit (includes connector removal tool, loopback plugs, and case utility tool)

4.2 Service Considerations

The following sections include some of the considerations that you should keep in mind during disassembly and assembly procedures.



As you remove each subassembly from the computer, place the subassembly (and all accompanying screws) away from the work area to prevent damage.

Plastic Parts

Using excessive force during disassembly and reassembly can damage plastic parts. Use care when handling the plastic parts. Apply pressure only at the points designated in the maintenance instructions.

Cables and Connectors

Cables must be handled with extreme care to avoid damage. Apply only the tension required to unseat or seat the cables during removal and insertion. Handle cables by the connector whenever possible. In all cases, avoid bending, twisting, or tearing cables. Ensure that cables are routed in such a way that they cannot be caught or snagged by parts being removed or replaced. Handle flex cables with extreme care; these cables tear easily.



CAUTION: When servicing the computer, ensure that cables are placed in their proper locations during the reassembly process. Improper cable placement can damage the computer.

4.3 Preventing Damage to Removable Drives

Removable drives are fragile components that must be handled with care. To prevent damage to the computer, damage to a removable drive, or loss of information, observe the following precautions:

- Before removing or inserting a hard drive, shut down the computer. If you are unsure whether the computer is off or in Hibernation, turn the computer on, then shut it down.
- Before removing a diskette drive or optical drive, ensure that a diskette or disc is not in the drive. Ensure that the optical drive tray is closed.
- Before handling a drive, ensure that you are discharged of static electricity. While handling a drive, avoid touching the connector.
- Handle drives on surfaces that have at least one inch of shock-proof foam.
- Avoid dropping drives from any height onto any surface.
- After removing a hard drive, CD-ROM drive, or a diskette drive, place it into a static-proof bag.
- Avoid exposing a hard drive to products that have magnetic fields such as monitors or speakers.
- Avoid exposing a drive to temperature extremes or to liquids.
- If a drive must be mailed, place the drive into a bubble pack mailer or other suitable form of protective packaging and label the package “Fragile: Handle With Care.”

4.4 Preventing Electrostatic Damage

Many electronic components are sensitive to electrostatic discharge (ESD). Circuitry design and structure determine the degree of sensitivity. Networks built into many integrated circuits provide some protection, but in many cases the discharge contains enough power to alter device parameters or melt silicon junctions.

A sudden discharge of static electricity from a finger or other conductor can destroy static-sensitive devices or microcircuitry. Often the spark is neither felt nor heard, but damage occurs. An electronic device exposed to electrostatic discharge may not be affected at all and can work perfectly throughout a normal cycle. The device may function normally for awhile, then degrade in the internal layers, reducing its life expectancy.

4.5 Packaging and Transporting Precautions

Use the following grounding precautions when packaging and transporting equipment:

- To avoid hand contact, transport products in static-safe containers such as tubes, bags, or boxes.
- Protect all electrostatic-sensitive parts and assemblies with conductive or approved containers or packaging.
- Keep electrostatic-sensitive parts in their containers until the parts arrive at static-free workstations.
- Place items on a grounded surface before removing items from their containers.
- Always be properly grounded when touching a sensitive component or assembly.

- Place reusable electrostatic-sensitive parts from assemblies in protective packaging or nonconductive foam.
- Use transporters and conveyers made of antistatic belts and roller bushings. Ensure that mechanized equipment used for moving materials is wired to ground and that proper materials are selected to avoid static charging. When grounding is not possible, use an ionizer to dissipate electric charges.

4.6 Workstation Precautions

Use the following grounding precautions at workstations:

- Cover the workstation with approved static-dissipative material (refer to Table 4-2).
- Use a wrist strap connected to a properly grounded work surface and use properly grounded tools and equipment.
- Use conductive field service tools, such as cutters, screwdrivers, and vacuums.
- When using fixtures that must directly contact dissipative surfaces, only use fixtures made of static-safe materials.
- Keep the work area free of nonconductive materials, such as ordinary plastic assembly aids and Styrofoam.
- Handle electrostatic-sensitive components, parts, and assemblies by the case or PCM laminate. Handle these items only at static-free workstations.
- Avoid contact with pins, leads, or circuitry.
- Turn off power and input signals before inserting or removing connectors or test equipment.

4.7 Grounding Equipment and Methods

Grounding equipment must include either a wrist strap or a foot strap at a grounded workstation.

- When seated, wear a wrist strap connected to a grounded system. Wrist straps are flexible straps with a minimum of one megaohm $\pm 10\%$ resistance in the ground cords. To provide proper ground, wear a strap snugly against the skin at all times. On grounded mats with banana-plug connectors, connect a wrist strap with alligator clips.
- When standing, use foot straps and a grounded floor mat. Foot straps (heel, toe, or boot straps) can be used at standing workstations and are compatible with most types of shoes or boots. On conductive floors or dissipative floor mats, use foot straps on both feet with a minimum of one-megaohm resistance between the operator and ground. To be effective, the conductive strips must be worn in contact with the skin.

Other grounding equipment recommended for use in preventing electrostatic damage includes:

- Antistatic tape
- Antistatic smocks, aprons, and sleeve protectors
- Conductive bins and other assembly or soldering aids
- Nonconductive foam
- Conductive tabletop workstations with ground cords of one-megaohm resistance
- Static-dissipative table or floor mats with hard tie to ground
- Field service kits
- Static awareness labels
- Material-handling packages

- Nonconductive plastic bags, tubes, or boxes
- Metal tote boxes
- Electrostatic voltage levels and protective materials

Table 4-1 shows how humidity affects the electrostatic voltage levels generated by different activities.

Table 4-1
Typical Electrostatic Voltage Levels

Event	Relative Humidity		
	10%	40%	55%
Walking across carpet	35,000 V	15,000 V	7,500 V
Walking across vinyl floor	12,000 V	5,000 V	3,000 V
Motions of bench worker	6,000 V	800 V	400 V
Removing DIPS from plastic tube	2,000 V	700 V	400 V
Removing DIPS from vinyl tray	11,500 V	4,000 V	2,000 V
Removing DIPS from Styrofoam	14,500 V	5,000 V	3,500 V
Removing bubble pack from PCB	26,500 V	20,000 V	7,000 V
Packing PCBs in foam-lined box	21,000 V	11,000 V	5,000 V

 A product can be degraded by as little as 700 volts.

Table 4-2 lists the shielding protection provided by antistatic bags and floor mats.

Table 4-2
Static-Shielding Materials

Material	Use	Voltage Protection Level
Antistatic plastic	Bags	1,500 V
Carbon-loaded plastic	Floor mats	7,500 V
Metallized laminate	Floor mats	5,000 V

Removal and Replacement Procedures

This chapter provides removal and replacement procedures.

There are 31 different Torx T8 and Phillips screws, screwlocks, and bushing guides, in 10 different sizes, that must be removed when servicing the computer. Make special note of the size and location of each screw during removal and replacement.

Refer to Appendix C, “Screw Listing,” for detailed information on screw sizes, locations, and usage.

5.1 Serial Number

Report the computer serial number to Compaq when requesting information or ordering spare parts. The serial number is located on the bottom of the computer as indicated in Figure 5-1.

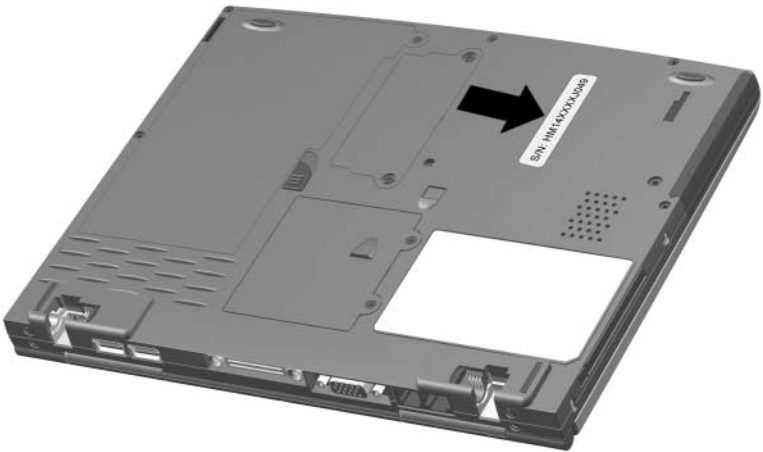

Figure 5-1. Serial Number Location

5.2 Disassembly Sequence Chart

Use the chart below to determine the section number to be referenced when removing computer components.

Table 5-1
Disassembly Sequence Chart

Section	Description	# of Screws Removed
5.3	Preparing the computer for disassembly	0
5.4	Computer feet	0
5.5	Modem/NIC	2
5.6	LED cover	0
5.7	Microphone	0
5.8	Keyboard	3
5.9	LED board and cable	2
5.10	Display	4
5.11	Top cover	14
5.12	RTC battery	0
5.13	System board	0
5.14	Charger board	2
5.15	Modem/NIC cable	0
5.16	Audio cable	0

5.3 Preparing the Computer for Disassembly

Perform the following steps before disassembling the computer. Consult the computer *Hardware Guide* for instructions on the following steps:

1. Shut down the computer.
2. Undock the computer from the MEU, if applicable.
3. Disconnect the AC adapter and external devices.
4. Remove any battery packs inserted into or attached to the computer.

5.4 Computer Feet

The computer feet are adhesive-backed rubber pads. The computer feet are included in the Miscellaneous Plastics Kit (spare part number 251638-001). Refer to Figure 5-2 for the locations of the computer feet.

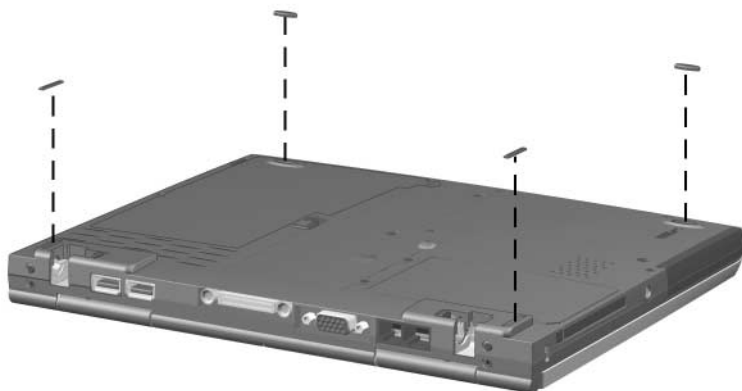

Figure 5-2. Replacing the Computer Feet

5.5 Modem/NIC

Modem/NIC Spare Part Number Information

Combination modem/network interface card (NIC)	233558-001
--	------------

1. Prepare the computer for disassembly (Section 5.3).
2. Turn the computer bottom side up with the front facing you.

3. Remove the two black PM2 × 4 screws ❶ that secure the mini PCI compartment cover to the base enclosure (Figure 5-3).



The mini PCI compartment cover is included in the Miscellaneous Plastics Kit (spare part number 251638-001).

4. Lift up the left edge of the mini PCI compartment cover and swing it up and to the right ❷.
5. Remove the mini PCI compartment cover.

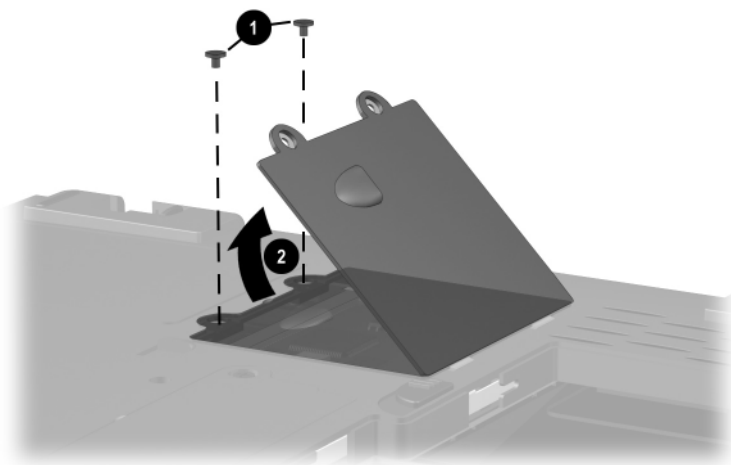

Figure 5-3. Removing the Mini PCI Compartment Cover

6. Disconnect the modem/NIC cable from the modem/NIC board ❶ (Figure 5-4).
7. Slide the modem/NIC cable into the mini PCI compartment until it clears the modem/NIC board ❷.
8. Spread the retaining tabs to release the modem/NIC ❸. The board tilts up to a 45-degree angle.
9. Remove the modem/NIC by pulling it away from the connector at a 45-degree angle.

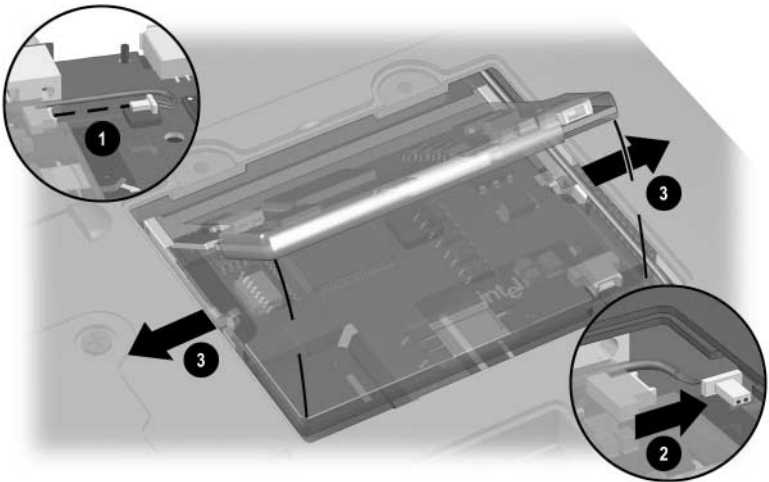

Figure 5-4. Removing the Modem/Network Interface Card

Reverse the above procedure to install the modem/NIC.

5.6 LED Cover



The LED cover is included in the Miscellaneous Plastics Kit (spare part number 251638-001).

1. Prepare the computer for disassembly (Section 5.3).
2. Turn the computer top side up with the front facing you.
3. Open the computer as far as it will open.
4. Swing the back edge of the LED cover up and forward ❶ and remove it ❷ (Figure 5-5).

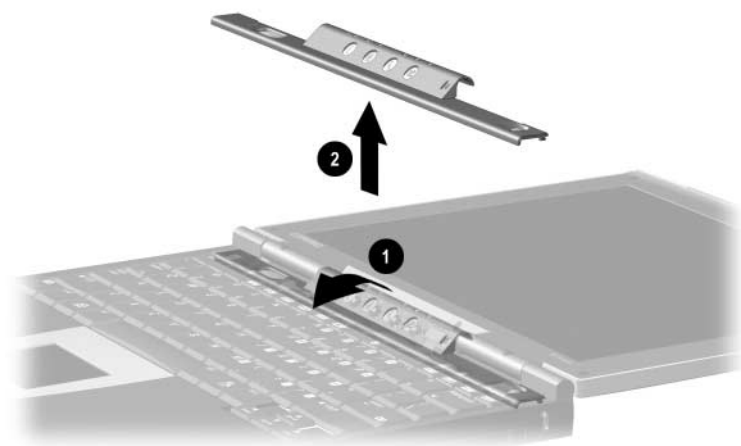

Figure 5-5. Removing the LED Cover

Reverse the above procedure to install the LED cover.

5.7 Microphone



The microphone is included in the Cable Kit (spare part number 251639-001).

1. Prepare the computer for disassembly (Section 5.3).
2. Remove the LED cover (Section 5.6).
3. Disconnect the microphone cable ❶ from the system board (Figure 5-6).
4. Remove the microphone ❷ from the top cover.

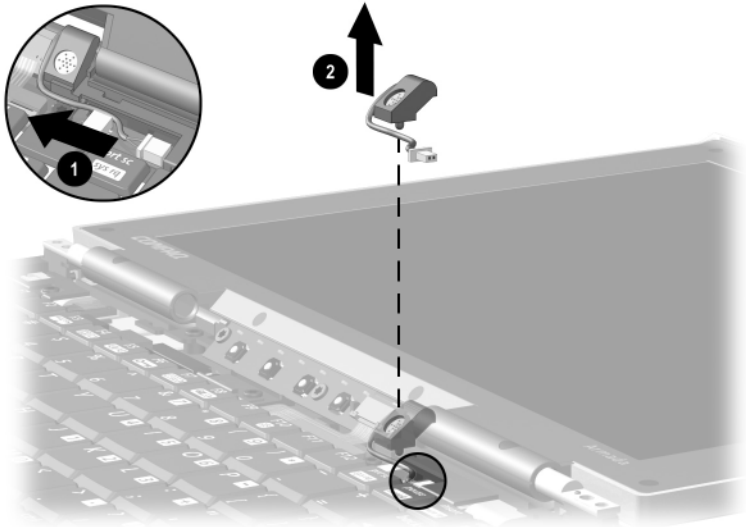

Figure 5-6. Removing the Microphone

Reverse the above procedure to install the microphone.

5.8 Keyboard

Keyboard Board Spare Part Number Information

Keyboards

Belgian	246339-181	Latin American	
Brazilian	246339-201	Spanish	246339-161
Czech	246339-221	Norwegian	246339-091
Danish	246339-081	Portuguese	246339-131
French	246339-051	Russian	246339-251
French Canadian	246339-121	Spanish	246339-071
German	246339-041	Swedish	246339-101
Hebrew	246339-BB1	Swiss	246339-111
Hungarian	246339-211	Taiwanese	246339-AB1
International	246339-002	Turkish	246339-141
Italian	246339-061	U.K. English	246339-031
Japanese	246339-291	U.S. English	246339-001
Korean	246339-AD1		

1. Prepare the computer for disassembly (Section 5.3).
2. Remove the LED cover (Section 5.6).

3. Remove the three black TM2 × 4 screws ❶ that secure the keyboard to the top cover and base enclosure (Figure 5-7).
4. Swing the back edge of the keyboard up and forward ❷ and rest the keyboard on the top cover.
5. Release the ZIF connector ❸ to which the keyboard cable is connected and disconnect the keyboard cable ❹.
6. Remove the keyboard.

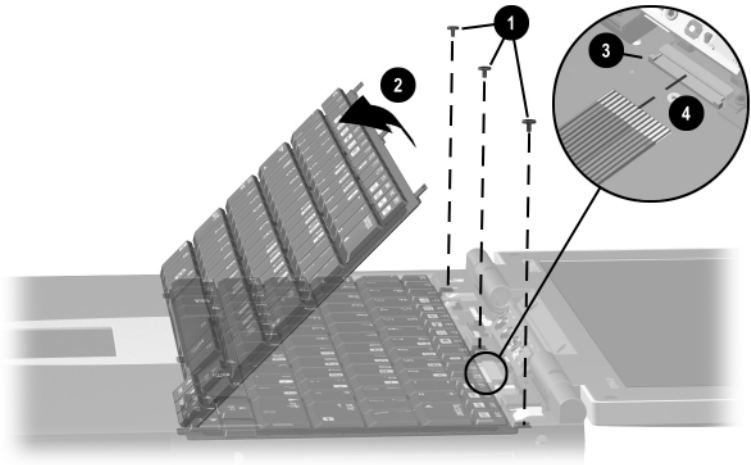

Figure 5-7. Removing the Keyboard

Reverse the above procedure to install the keyboard.

5.9 LED Board

LED Board Spare Part Number Information

LED board

251631-001

1. Prepare the computer for disassembly (Section 5.3).

2. Remove the LED cover (Section 5.6).
3. Remove the microphone (Section 5.7).
4. Remove the keyboard (Section 5.8).
5. Release the ZIF connector ❶ to which the LED board cable is connected and disconnect the LED board cable ❷ (Figure 5-8).
6. Remove the two black TM2 × 4 screws ❸ that secure the LED board to the top cover.
7. Remove the LED board ❹.

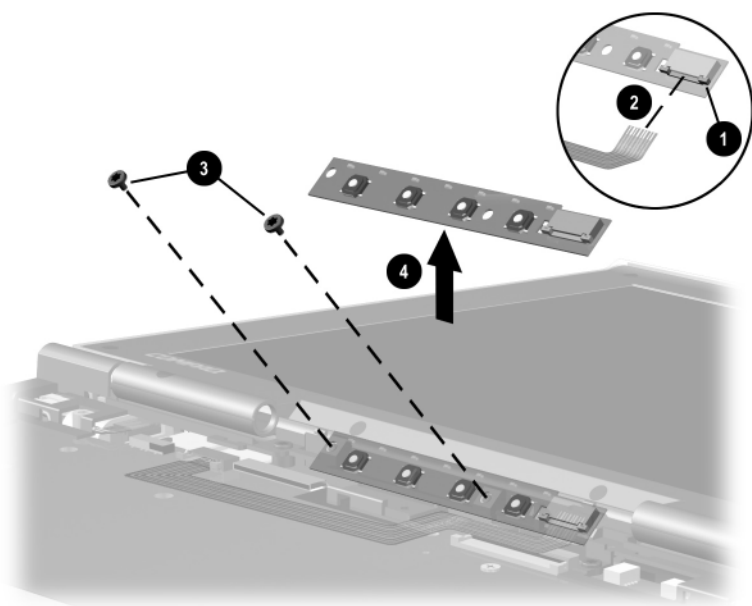

Figure 5-8. Removing the LED Board



The LED board cable is included in the Cable Kit (spare part number 251639-001).

To remove the LED board cable from the system board:

1. Release the ZIF connector ❶ to which the LED board cable is connected and disconnect the LED board cable ❷ (Figure 5-9).
2. Remove the LED board cable ❸.

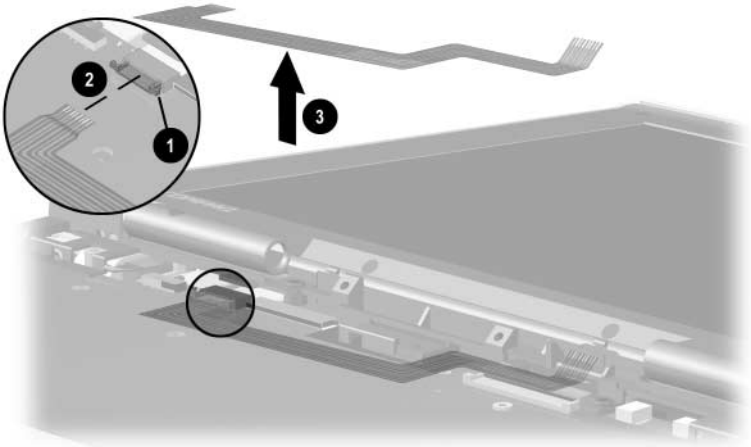

Figure 5-9. Removing the LED Board Cable

Reverse the above procedure to install the LED board and LED board cable.

5.10 Display



When the display screws are removed, the assembly is unsupported. Make sure to provide support for the display when removing the display screws.

Display Spare Part Number Information

10.4-inch XGA TFT display

251633-001

1. Prepare the computer for disassembly (Section 5.3) and remove the following components:
 - a. LED cover (Section 5.6)
 - b. Microphone (Section 5.7)
 - c. Keyboard (Section 5.8)
 - d. LED board and cable (Section 5.9)

2. Slide the left and right hinge covers away from the computer ❶ (Figure 5-10).



The hinge covers are included in the Miscellaneous Plastics Kit (spare part number 251638-001).

3. Disconnect the display inverter ❷ and video cables ❸ from the system board.
4. Remove the two silver TM2 × 15 screws ❹ and the two black TM2 × 5 screws ❺ that secure the display to the top cover and base enclosure.

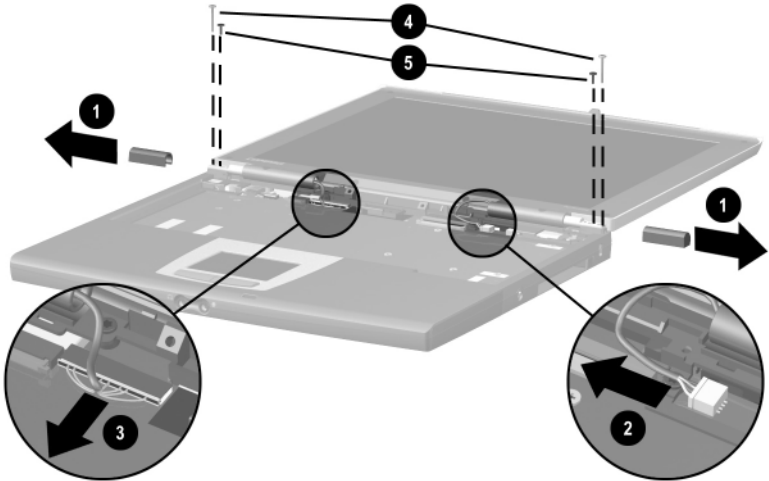

Figure 5-10. Removing the Display

5. Remove the display.



To ensure proper alignment of the display during replacement, loosely install the screws in the ①, ②, ③, ④ sequence indicated in Figure 5-11. Tighten the screws after all four have been loosely installed.

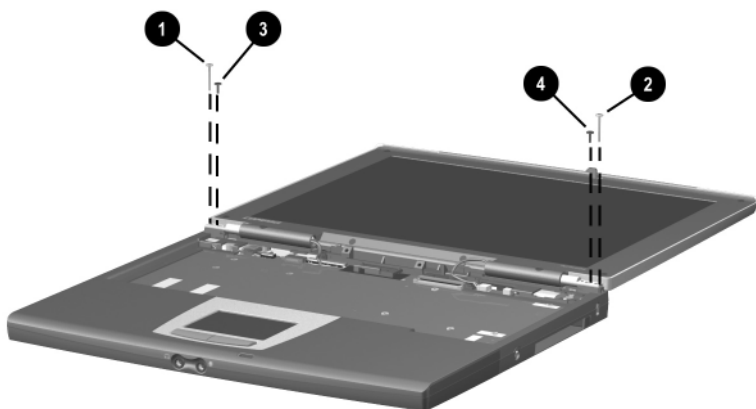

Figure 5-11. Installing the Display Screws

5.11 Top Cover

Top Cover Spare Part Number Information

Top cover

251643-001

1. Prepare the computer for disassembly (Section 5.3) and remove the following components:
 - a. LED cover (Section 5.6)
 - b. Microphone (Section 5.7)
 - c. Keyboard (Section 5.8)
 - d. LED board and cable (Section 5.9)
 - e. Display (Section 5.10)
2. Turn the computer bottom side up with the front facing you.

3. Remove the six pewter TM2 × 8 screws (Figure 5-12).

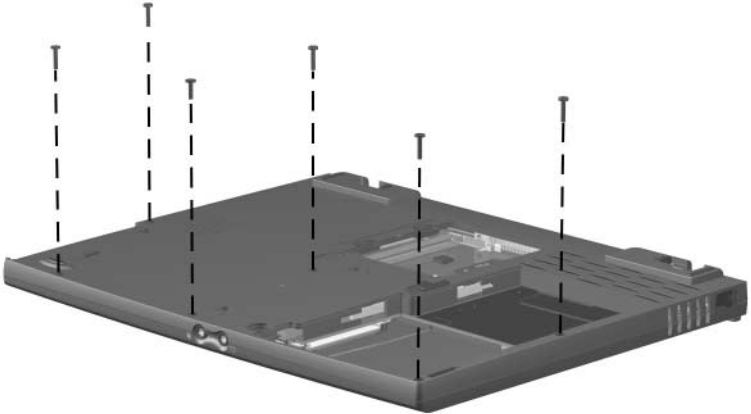

Figure 5-12. Removing the Top Cover Screws

4. Turn the computer top side up with the rear panel facing you.

5. Remove the following screws:
 - ❑ two pewter TM2 × 8 screws ❶ that secure the top cover to the base enclosure (Figure 5-13)
 - ❑ two black TM2 × 4 screws ❷ from the rear panel
 - ❑ two 5.0 mm screwlocks ❸ on each side of the external monitor connector
6. Use a 9/64" hex wrench to remove the two bushing guides ❹ on each side of the docking connector.

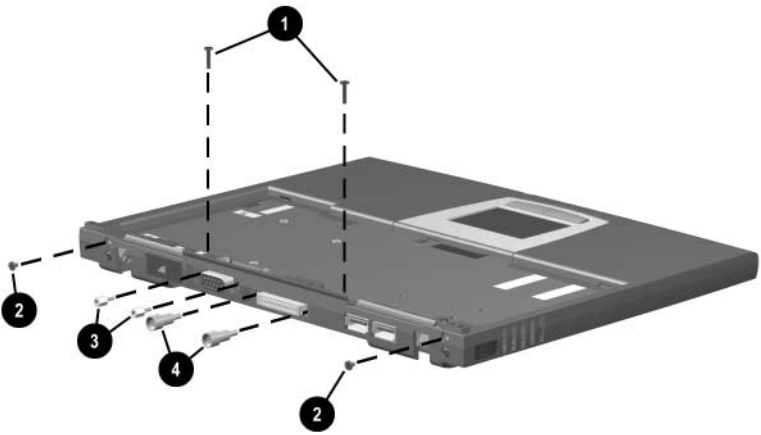

Figure 5-13. Removing the Top Cover Screws (Continued)

7. Lift up the back edge of the top cover ❶ until the TouchPad cable ❷ prevents it from lifting any farther (Figure 5-14).
8. Release the ZIF connector ❸ to which the TouchPad cable is connected and disconnect the TouchPad cable ❹.



The LED board cable is included in the Cable Kit (spare part number 251639-001).

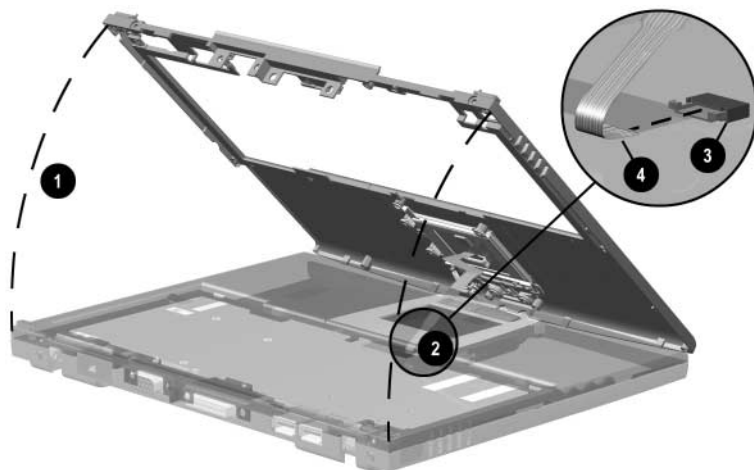

Figure 5-14. Removing the Top Cover

9. Remove the top cover.

Reverse the above procedure to install the top cover.

5.12 RTC Battery

RTC Battery Spare Part Number Information

RTC battery

252443-001

1. Prepare the computer for disassembly (Section 5.3) and remove the following components:
 - a. LED cover (Section 5.6)
 - b. Microphone (Section 5.7)
 - c. Keyboard (Section 5.8)
 - d. LED board and cable (Section 5.9)
 - e. Display (Section 5.10)
 - f. Top cover (Section 5.11)

2. Disconnect the RTC battery cable from the system board ❶ (Figure 5-15).
3. Remove the RTC battery from the slot in the base enclosure ❷.

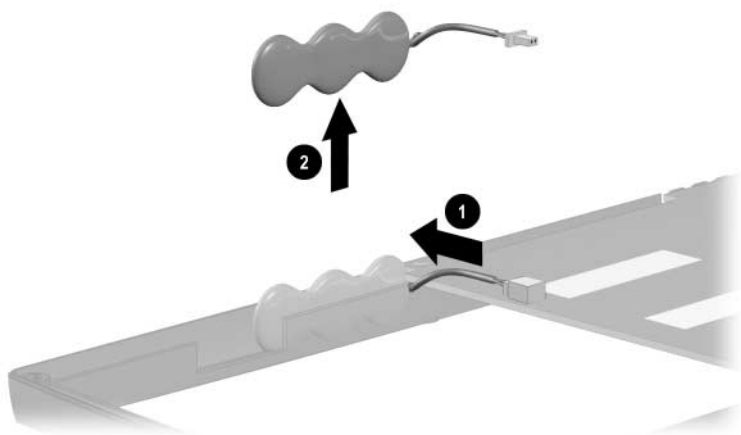

Figure 5-15. Removing the Real Time Clock Battery

4. Remove the RTC Battery.

Reverse the above procedure to install the RTC Battery.

5.13 System Board

System Board Spare Part Number Information

System board with 700-MHz Intel Pentium III processor and 64 MB SDRAM	251642-001
--	------------

1. Prepare the computer for disassembly (Section 5.3) and remove the following components:
 - a. LED cover (Section 5.6)
 - b. Microphone (Section 5.7)
 - c. Keyboard (Section 5.8)
 - d. LED board and cable (Section 5.9)
 - e. Display (Section 5.10)
 - f. Top cover (Section 5.11)
 - g. RTC battery (Section 5.12)

2. Disconnect the left ❶ and right ❷ external battery terminal cables and the speaker cable ❸ (Figure 5-16).

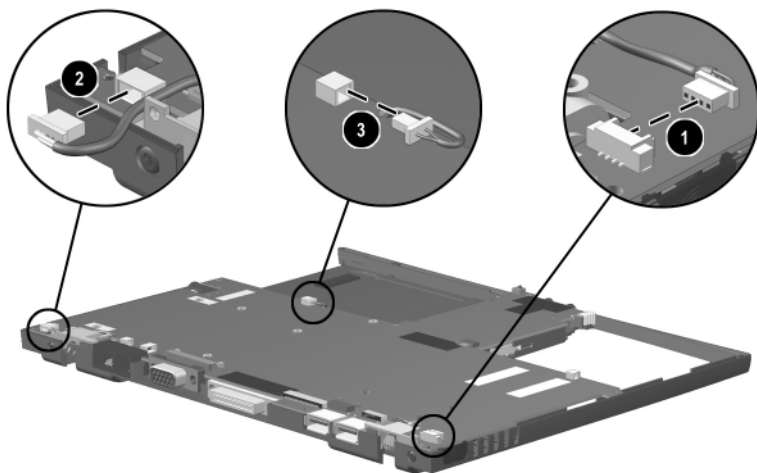

Figure 5-16. Disconnecting the Battery Terminal and Speaker Cables

3. Lift up the right side of the system board ❶ until it rests at a 45-degree angle.
4. Slide the system board to the right at a 45-degree angle ❷ (Figure 5-17).

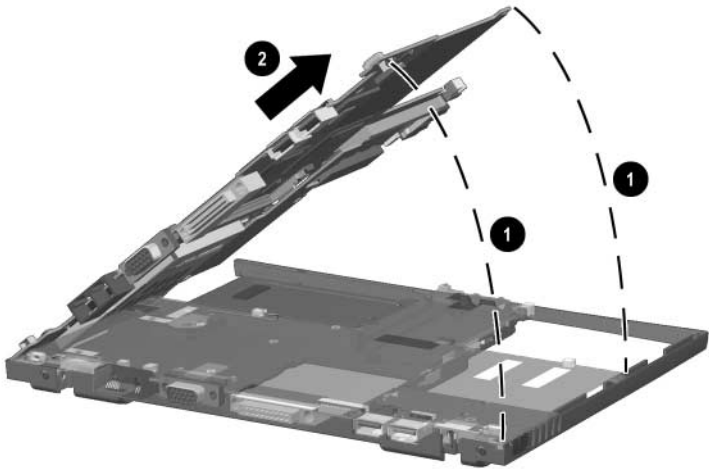

Figure 5-17. Removing the System Board

Reverse the above procedure to install the system board.

5.14 Charger Board

Charger Board Spare Part Number Information

Charger board

251640-001

1. Prepare the computer for disassembly (Section 5.3) and remove the following components:
 - a. LED cover (Section 5.6)
 - b. Microphone (Section 5.7)
 - c. Keyboard (Section 5.8)
 - d. LED board and cable (Section 5.9)
 - e. Display (Section 5.10)
 - f. Top cover (Section 5.11)
 - g. RTC battery (Section 5.12)
 - h. System board (Section 5.13)
2. Turn the system board top side up with the front facing you.

3. Remove the two silver PM1x6 screws ❶ that secure the charger board to the system board (Figure 5-18).
4. Turn the system board top side up with the stereo speaker and headphone jacks facing you.
5. Lift up on the left front side ❷ and center ❸ of the charger board to disconnect it from the system board.

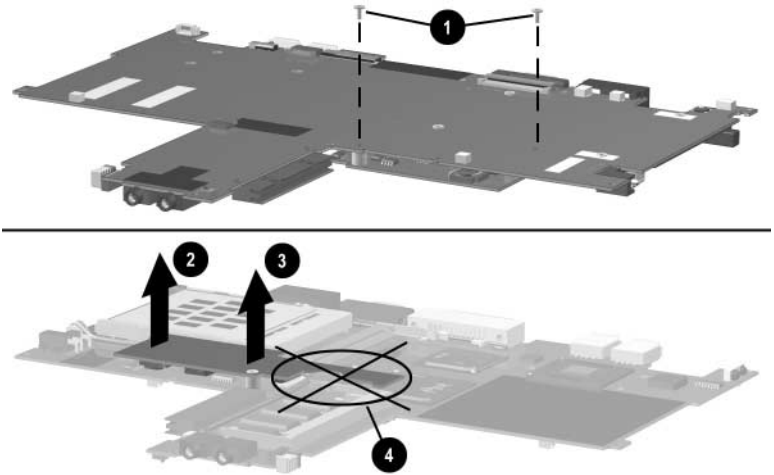

Figure 5-18. Removing the Charger Board



CAUTION: Do not lift the charger board by the right side ❹. The material on the right side of the board is thinner and more prone to damage. Failure to follow this caution can result in damage to the charger board and the computer.

6. Remove the charger board.

Reverse the above procedure to install the charger board.

5.15 Modem/NIC Cable



The modem/NIC cable is included in the Cable Kit (spare part number 251639-001).

1. Prepare the computer for disassembly (Section 5.3) and remove the following components:
 - a. LED cover (Section 5.6)
 - b. Microphone (Section 5.7)
 - c. Keyboard (Section 5.8)
 - d. LED board and cable (Section 5.9)
 - e. Display (Section 5.10)
 - f. Top cover (Section 5.11)
 - g. RTC battery (Section 5.12)
 - h. System board (Section 5.13)
2. Turn the system board bottom side up with the rear panel facing you.

3. Disconnect the modem/NIC cable from the system board ❶ (Figure 5-19).
4. Remove the modem/NIC cable ❷.



When installing the modem/NIC cable, route the cable between the docking connector ❸ and the mini PCI connector ❹.

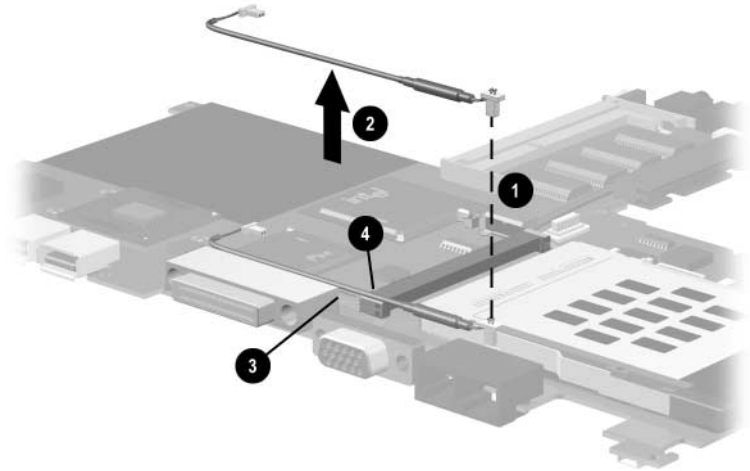

Figure 5-19. Removing the Modem/NIC Cable

Reverse the above procedure to install the modem/NIC cable.

5.16 Audio Cable



The audio cable is included in the Cable Kit (spare part number 251639-001).

1. Prepare the computer for disassembly (Section 5.3) and remove the following components:
 - a. LED cover (Section 5.6)
 - b. Microphone (Section 5.7)
 - c. Keyboard (Section 5.8)
 - d. LED board and cable (Section 5.9)
 - e. Display (Section 5.10)
 - f. Top cover (Section 5.11)
 - g. RTC battery (Section 5.12)
 - h. System board (Section 5.13)
2. Turn the system board bottom side up with the front facing you.

3. Disconnect both connectors on the audio cable ❶ from the system board (Figure 5-20).
4. Remove the audio cable ❷.

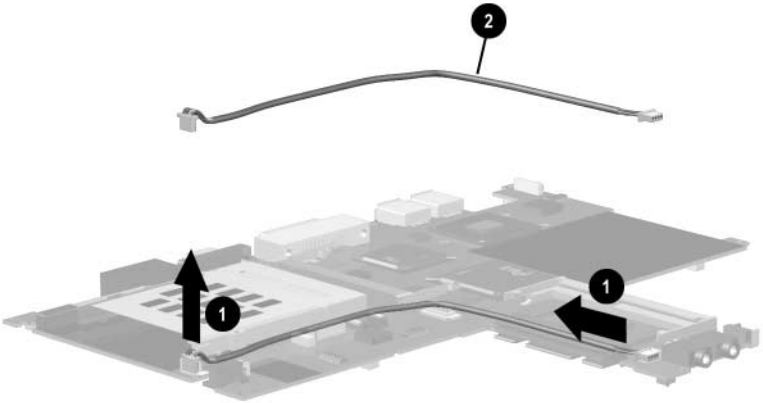

Figure 5-20. Removing the Audio Cable

Reverse the above procedure to install the audio cable.

6

Specifications

This chapter provides physical and performance specifications.

Table 6-1
Computer

Dimensions		
Height	.89 in	22 mm
Width	10.5 in	266 mm
Depth	9.5 in	242 mm
Weight	3.5 lb	1.59 kg
Standalone (battery) power requirements		
Nominal operating voltage (Li ion)	14.8 VDC	
Maximum operating power	40 W	
Peak operating power	50 W	
AC adapter power requirements		
Rated input power	90 to 264 VAC RMS (auto switching)	
Rated input current	< 60 W	
Rated frequency	47 to 63 Hz	
Temperature		
Operating	50 to 95°F	10 to 35°C
Nonoperating	-4 to 140°F	-20 to 60°C

Table 6-1
Computer (*Continued*)

Relative humidity

Operating	10 to 90% relative humidity, non-condensing
Nonoperating	5 to 90% relative humidity, 101.6°F/38.7°C maximum wet bulb temperature

Altitude (unpressurized)

Operating (14.7 to 10.1 psia)	0 to 10,000 ft	0 to 3,048 m
Nonoperating (14.7 to 14.4 psia)	0 to 30,000 ft	0 to 9,144 m

Shock

Operating	10 G, 11 ms, half sine
Nonoperating	60 G, 11 ms, half sine

Vibration

Operating	0.5 G, 10 to 500 Hz, 0.5 oct/min sweep rate
Nonoperating	1.0 G, 10 to 500 Hz, 0.50 oct/min sweep rate



Applicable product safety standards specify thermal limits for plastic surfaces. The computer operates well within this range of temperatures.

Table 6-2
10.4-inch XGA, TFT Display

Dimensions		
Height	6.4 in	162 mm
Width	8.2 in	209 mm
Diagonal	10.1 in	264 mm
Number of colors	Up to 16.8 million	
Contrast ratio	125:1	
Brightness	130 nits typical on AC power, 70 nits typical on battery power, 115 nits minimum	
Pixel resolution		
Pitch		0.264 × 0.264 mm
Format	1024 × 768	
Configuration	RGB vertical stripe	
Backlight	Cold cathode fluorescent, 1 tube	
Character display	80 × 25	
Refresh rate	60 Hz	
Total power consumption	4 W	

**Table 6-3
Hard Drives**

	20.0 GB	10.0 GB
User capacity per drive¹	20.0 GB	10.0 GB
Drive height (with drive frame)	0.38 in, 9.5 mm	0.38 in, 9.5 mm
Drive width (with drive frame)	2.50 in, 70 mm	2.50 in, 70 mm
Interface type	ATA-5	ATA-4
Seek times (typical read, including setting)		
Single track	2.5 ms	2.5 ms
Average	12.0 ms	12.0 ms
Full stroke	23.0 ms	23.0 ms
User addressable sectors³	39,070,080	19,640,880
Logical configuration		
Cylinders	16,383	16,383
Heads	16	16
Sectors per track	63	63

Table 6-3
Hard Drives (Continued)

	20.0 GB	10.0 GB
Physical configuration		
Cylinders ³	22,784	22,784
Heads	4	2
Sectors per track ³	293–560	293–560
Bytes per sector	512	512
Buffer size³	2 MB	512KB
Disk rotational speed	4200 rpm	4200 rpm
Transfer rate		
Interface max (MB/s) ²	66.6	66.6
Media (Mb/s) ³	109–203	109–203

¹ 1 GB = 1,000,000,000 bytes.

² System capability may differ.

³ Actual drive specifications may differ slightly.

Certain restrictions and exclusions apply. Consult the Compaq Customer Support Center for details.

Table 6-4
Battery Packs

Dimensions

Primary Lithium ion (Li ion)		
Height	.78 in	20 mm
Width	9.06 in	231 mm
Depth	1.84 in	47 mm
Weight	.49 lb	.22 kg
Cells	4	
External Li ion		
Height	.9 in	23 mm
Width	10.47 in	266 mm
Depth	.9 in	23 mm
Weight	.48 lb	.22 kg
Cells	4	
External Li ion High Capacity		
Height	1.8 in	46 mm
Width	10.6 in	269 mm
Depth	1.2 in	30 mm
Weight	.93 lb	.42 kg
Cells	4	

Energy

Primary and External Li ion		
Voltage	14.4 V	
Amp-hour capacity	1.96 Ah	
Watt-hour capacity	28 Wh	
External Li ion High Capacity		
Voltage	14.4 V	
Amp-hour capacity	2.87 Ah	
Watt-hour capacity	349 Wh	

Environmental requirements

Temperature		
Operating	41°F to 95°F	5°C to 35°C
Nonoperating	-4°F to 140°F	-20°C to 60°C

**Table 6-5
AC Adapter**

Weight	0.39 lb	.18 kg
Power supply (input)		
Operating voltage	90 to 260 VAC RMS Nominal	
Operating current	1.3 A RMS	
Operating frequency range	47 to 63 Hz Nominal	
Maximum transient	4/50 kV	

**Table 6-6
System DMA**

Hardware DMA	System Function
DMA0	Available for audio
DMA1	Entertainment audio (default; alternate = DMA0, DMA3, none)
DMA2	Diskette drive
DMA3	ECP parallel port LPT1 (default; alternate = DMA0, none)
DMA4	DMA controller cascading (not available)
DMA5	Available for PC Card
DMA6	Not assigned
DMA7	Not assigned



 PC Card controller can use DMA 1, 2, or 5.

Table 6-7
System Interrupts

Hardware IRQ	System Function
IRQ0	System timer
IRQ1	Keyboard controller
IRQ2	Cascaded
IRQ3	COM2
IRQ4	COM1
IRQ5	Audio (default)*
IRQ6	Diskette drive
IRQ7	Parallel port
IRQ8	Real time clock (RTC)
IRQ9	Infrared
IRQ10	System use
IRQ11	System use
IRQ12	Internal point stick or external mouse
IRQ13	Coprocessor (not available to any peripheral)
IRQ14	IDE interface (hard drive and optical drive)
IRQ15	System use

 PC Cards may assert IRQ3, IRQ4, IRQ5, IRQ7, IRQ9, IRQ10, IRQ11, or IRQ15. Either the infrared or the serial port may assert IRQ3 or IRQ 4.

*Default configuration; audio possible configurations are IRQ5, IRQ7, IRQ9, IRQ10, or none.

Table 6-8
System I/O Addresses

I/O Address (hex)	System Function (shipping configuration)
000 - 00F	DMA controller no. 1
010 - 01F	Unused
020 - 021	Interrupt controller no. 1
022 - 024	Opti chipset configuration registers
025 - 03F	Unused
02E - 02F	87334 "Super IO" configuration for CPU
040 - 05F	Counter/timer registers
044 - 05f	Unused
060	Keyboard controller
061	Port B
062 - 063	Unused
064	Keyboard controller
065 - 06F	Unused
070 - 071	NMI enable/real time clock
072 - 07F	Unused
080 - 08F	DMA page registers
090 - 091	Unused
092	Port A
093 - 09F	Unused
0A0 - 0A1	Interrupt controller no. 2

Table 6-8
System I/O Addresses (*Continued*)

I/O Address (hex)	System Function (shipping configuration)
0A2 - 0BF	Unused
0C0 - 0DF	DMA controller no. 2
0E0 - 0EF	Unused
0F0 - 0F1	Coprocessor busy clear/reset
0F2 - 0FF	Unused
100 - 16F	Unused
170 - 177	Secondary fixed disk controller
178 - 1EF	Unused
1F0 - 1F7	Primary fixed disk controller
1F8 - 200	Unused
201	Joystick (decoded in ESS1688)
202 - 21F	Unused
220 - 22F	Entertainment audio
230 - 26D	Unused
26E - 26	Unused
278 - 27F	Unused
280 - 2AB	Unused
2A0 - 2A7	Unused
2A8 - 2E7	Unused
2E8 - 2EF	Reserved serial port

Table 6-8
System I/O Addresses (Continued)

I/O Address (hex)	System Function (shipping configuration)
2F0 - 2F7	Unused
2F8 - 2FF	Infrared port
300 - 31F	Unused
320 - 36F	Unused
370 - 377	Secondary diskette drive controller
378 - 37F	Parallel port (LPT1/default)
380 - 387	Unused
388 - 38B	FM synthesizer - OPL3
38C - 3AF	Unused
3B0 - 3BB	VGA
3BC - 3BF	Reserved (parallel port/no EPP support)
3C0 - 3DF	VGA
3E0 - 3E1	PC Card controller in CPU
3E2 - 3E3	Unused
3E8 - 3EF	Internal modem
3F0 - 3F7	"A" diskette controller
3F8 - 3FF	Serial port (COM1/default)
CF8 - CFB	PCI configuration index register (PCIDIVO-1)
CFC - CFF	PCI configuration data register (PCIDIVO-1)

Table 6-9
System Memory Map

Size	Memory Address	System Function
640 KB	00000000 - 0009FFFF	Base memory
128 KB	000A0000 - 000BFFFF	Video memory
48 KB	000C0000 - 000CBFFF	Video BIOS
160 KB	000C8000 - 000E7FFF	Unused
64 KB	000E8000 - 000FFFFF	System BIOS
15 MB	00100000 - 00FFFFFF	Extended memory
58 MB	01000000 - 047FFFFF	Super extended memory
58 MB	04800000 - 07FFFFFF	Unused
2 MB	08000000 - 080FFFFF	Video memory (direct access)
4 GB	08200000 - FFFEFFFF	Unused
64 KB	FFFF0000 - FFFFFFFF	System BIOS

A

Connector Pin Assignments

Table A-1
Stereo Speaker/Headphone

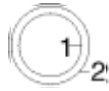

Pin	Signal	Pin	Signal
1	Audio out	2	Ground

Table A-2
Microphone



Pin	Signal	Pin	Signal
1	Audio in	2	Ground

Table A-3
Universal Serial Bus

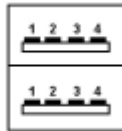

Pin	Signal	Pin	Signal
1	+5 VDC	3	Data +
2	Data -	4	Ground

Table A-4
RJ-45 Network Interface

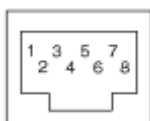

Pin	Signal	Pin	Signal
1	Transmit +	5	Unused
2	Transmit -	6	Receive -
3	Receive +	7	Unused
4	Unused	8	Unused

Table A-5
RJ-11 Modem

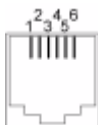

Pin	Signal	Pin	Signal
1	Unused	4	Unused
2	Tip	5	Unused
3	Ring	6	Unused

Table A-6
External Monitor

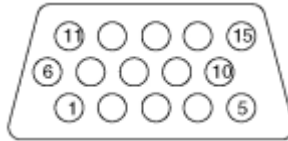

Pin	Signal	Pin	Signal
1	Red analog	9	+5 VDC
2	Green analog	10	Ground
3	Blue analog	11	Monitor detect
4	Not connected	12	DDC 2B data
5	Ground	13	Horizontal sync
6	Ground analog	14	Vertical sync
7	Ground analog	15	DDC2B clock
8	Ground analog		

Power Cord Set Requirements

3-Conductor Power Cord Set

The computer's wide range input feature permits it to operate from any line voltage from 100 to 120 or 220 to 240 volts AC.

The power cord set received with the computer meets the requirements for use in the country where the equipment is purchased.

Power cord sets for use in other countries must meet the requirements of the country where the computer is used. For more information on power cord set requirements, contact a Compaq authorized reseller or service provider.

General Requirements

The requirements listed below are applicable to all countries:

- The length of the power cord set must be at least 5.00 feet (1.5 m) and a maximum of 6.50 feet (2.0 m).
- All power cord sets must be approved by an acceptable accredited agency responsible for evaluation in the country where the power cord set will be used.
- The power cord set must have a minimum current capacity of 10A and a nominal voltage rating of 125 or 250 volts AC, as required by each country's power system.
- The appliance coupler must meet the mechanical configuration of an EN 60 320/IEC 320 Standard Sheet C13 connector, for mating with appliance inlet on the back of the computer.

Country-Specific Requirements

3-Conductor Power Cord Set Requirements—By Country

Country	Accredited Agency	Applicable Note Number
Australia	EANSW	1
Austria	OVE	1
Belgium	CEBC	1
Canada	CSA	2
Denmark	DEMKO	1
Finland	FIMKO	1
France	UTE	1
Germany	VDE	1
Italy	IMQ	1
Japan	METI	3
The Netherlands	KEMA	1
Norway	NEMKO	1
Sweden	SEMKO	1
Switzerland	SEV	1
United Kingdom	BSI	1
United States	UL	2

Notes

1. The flexible cord must be <HAR> Type HO5VV-F, 3-conductor, 1.0mm² conductor size. Power cord set fittings (appliance coupler and wall plug) must bear the certification mark of the agency responsible for evaluation in the country where it will be used.
2. The flexible cord must be Type SPT-3 or equivalent, No. 18 AWG, 3-conductor. The wall plug must be a two-pole grounding type with a NEMA 5-15P (15A, 125V) or NEMA 6-15P (15A, 250V) configuration.
3. The appliance coupler, flexible cord, and wall plug must bear a “T” mark and registration number in accordance with the Japanese Dentori Law. The flexible cord must be Type VCT or VCTF, 3-conductor, 1.0 mm² conductor size. The wall plug must be a two-pole grounding type with a Japanese Industrial Standard C8303 (7A, 125V) configuration.

C

Screw Listing

This appendix provides specification information for the screws used in the computer. All screws listed in this appendix are available in the Screw Kit, spare part number 251641-001.

Table C-1
Phillips PO M2 x 10 Screw



	Color	Qty	Length	Thread	Head Width
	Black	1	10.0 mm	M2	4.5 mm

Where used:

One screw securing the battery pack to the base enclosure (refer to the *Hardware Guide* shipped with the computer for installation information.)

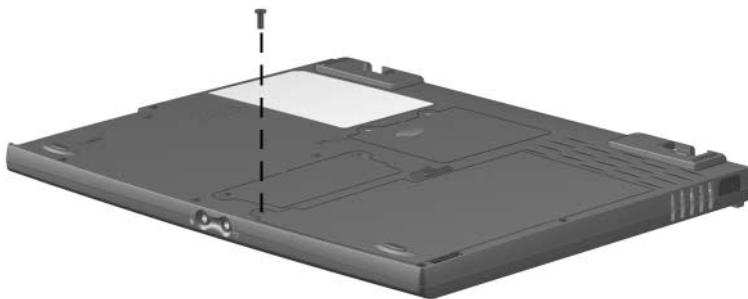

Table C-2
Torx T8 M2.5 × 5 Screw



Color	Qty	Length	Thread	Head Width
Black	1	5.0 mm	M2.5	5.5 mm

Where used:

One screw securing the hard drive to the base enclosure (refer to the *Hardware Guide* shipped with the computer for installation information.)

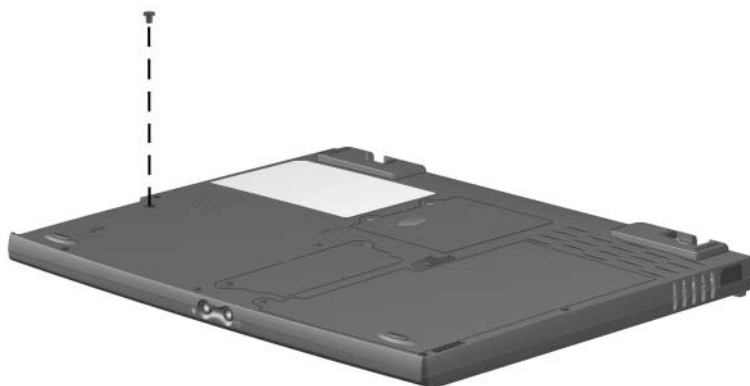

Table C-3
Phillips P0 M2 × 4 Screw



Color	Qty	Length	Thread	Head Width
Black	4	4.0 mm	M2.0	4.5 mm

Where used:

- ❶ Two screws securing the memory expansion compartment cover to the base enclosure (Refer to the *Hardware Guide* shipped with the computer for installation information.)
 - ❷ Two screws securing the mini PCI compartment cover to the base enclosure (documented in Section 5.5)
-

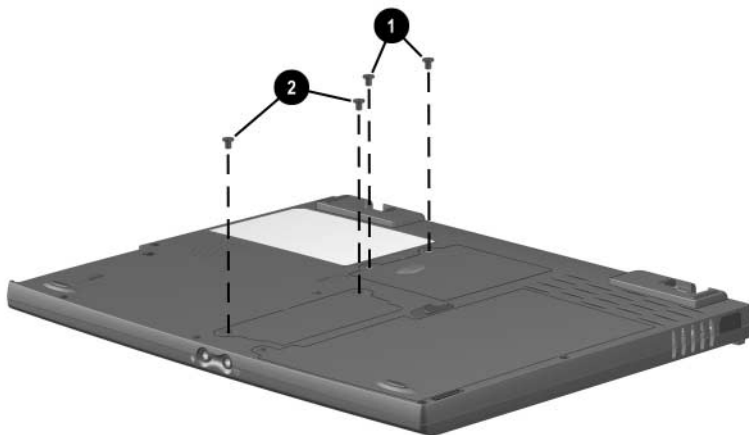

Table C-4
Torx T8 M2 x 4 Screw



	Color	Qty	Length	Thread	Head Width
	Black	7	4.0 mm	M2.0	4.5 mm

Where used:

- ❶ Three screws securing the keyboard to the top cover and base enclosure (documented in Section 5.8)
 - ❷ Two screws securing the LED board to the top cover (documented in Section 5.9)
-

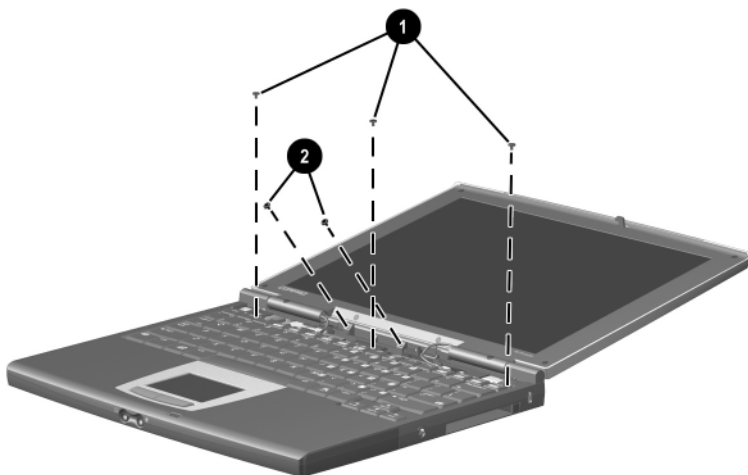

Table C-4
Torx T8 M2 x 4 Screw (Continued)



	Color	Qty	Length	Thread	Head Width
	Black	7	4.0 mm	M2.0	4.5 mm

Where used:

Two screws securing the top cover to the base enclosure (documented in Section 5.11)



Table C-5
Torx T8 M2 × 15 Screw



	Color	Qty	Length	Thread	Head Width
	Silver	2	15.0 mm	M2	4.5 mm

Where used:

Two screws securing the display the base enclosure (documented in Section 5.10)

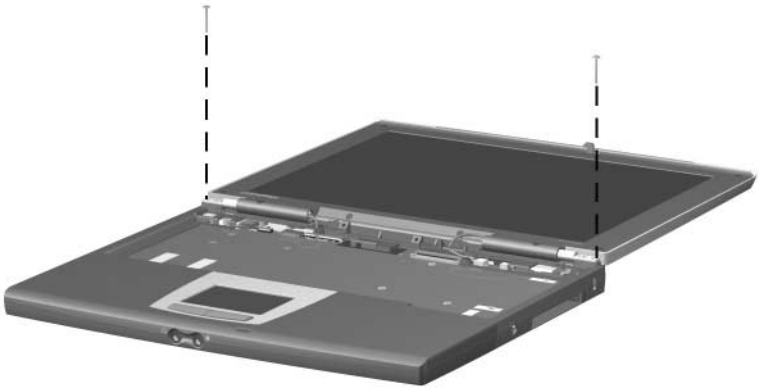

Table C-6
Torx T8 M2 × 5 Screw



Color	Qty	Length	Thread	Head Width
Black	2	5.0 mm	M2	4.5 mm

Where used:

One screw securing the display the top cover (documented in Section 5.10)

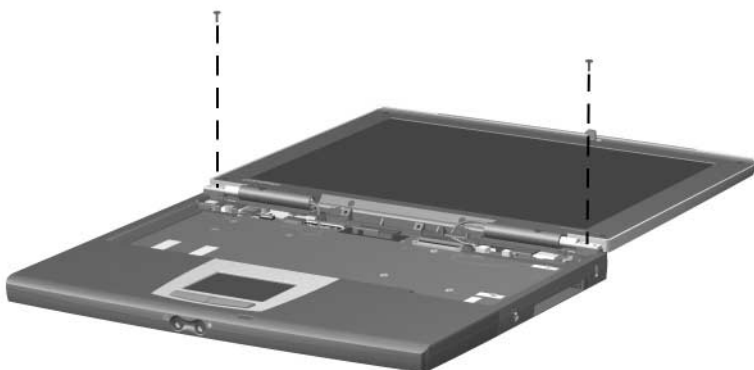

Table C-7
Torx T8 M2 × 8 Screw



Color	Qty	Length	Thread	Head Width
Pewter	8	8.0 mm	M2	4.5 mm

Where used:

Six screws securing the top cover to the base enclosure through the bottom of the computer (documented in Section 5.11)

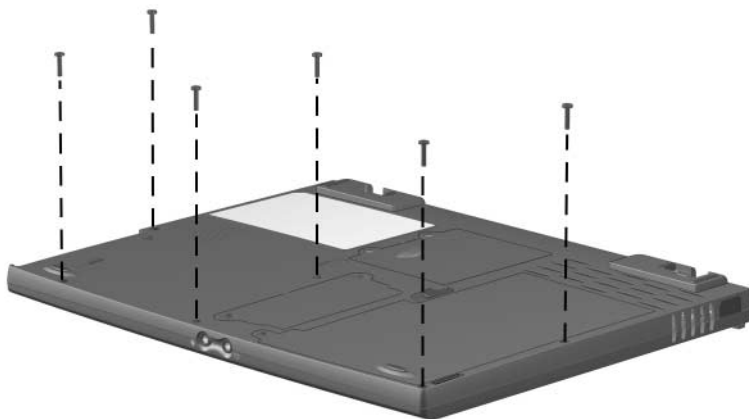

Table C-7
Torx T8 M2 × 8 Screw (Continued)



Color	Qty	Length	Thread	Head Width
Pewter	8	8.0 mm	M2	4.5 mm

Where used:

Two screws securing the top cover to the base enclosure through the top of the computer (documented in Section 5.11)

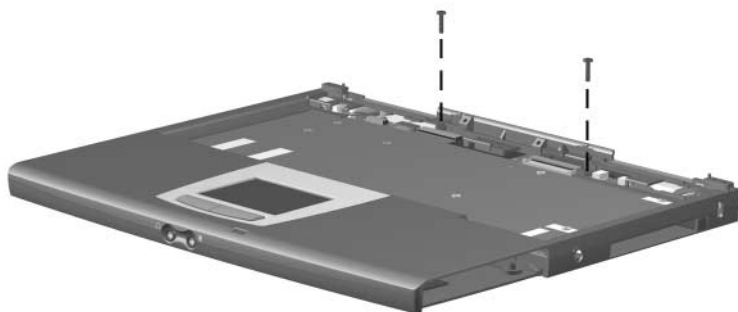

Table C-8
5.0 mm × 9.5 Screwlock



Color	Qty	Length	Thread	Head Width
Silver	2	9.5 mm	n/a	5.0 mm

Where used:

Two screwlocks securing the top cover to the base enclosure on each side of the external monitor connector (documented in Section 5.11)



Table C-9
9/64" Hex Wrench Bushing Guide

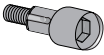

	Color	Qty	Length	Thread	Head Width
	Silver	2	17.5 mm	n/a	7.0 mm

Where used:

Two bushing guides securing the top cover to the base enclosure on each side of the docking connector (documented in Section 5.11)



Table C-10
Phillips P0 M1.5 x 6 Screw



Color	Qty	Length	Thread	Head Width
Silver	2	6.0 mm	1.5 mm	4.0 mm

Where used:

Two screws securing the charger board to the system (documented in Section 5.14)

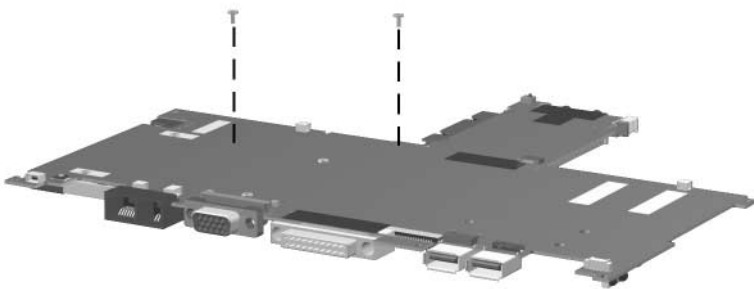

Index

A

- AC adapter
 - spare part number 3–8
 - specifications 6–7
- audio cable
 - illustrated 3–7
 - removal 5–31
- audio troubleshooting 2–17

B

- base enclosure
 - illustrated 3–4
 - spare part number 3–5
- battery components
 - bay 1–15
 - charger, spare part number 3–8
 - external battery pack
 - release latches 1–15
 - light 1–13
 - primary battery pack
 - release latches 1–15
- battery pack
 - illustrated 3–4
 - spare part numbers 3–5
 - specifications 6–6
- bottom components 1–14

C

- Cable Kit
 - illustrated 3–2, 3–7
 - spare part number 3–3, 3–7
- cables 4–2
- caps lock key 1–11
- caps lock light 1–13
- CD-ROM drive
 - OS loading problems 2–16
- CD-ROM drive (used with MEU), spare part number 3–9
- Certificate of Authenticity label 1–15
- charger board
 - illustrated 3–4
 - removal 5–27
 - spare part number 3–5, 5–27
- components
 - bottom 1–14
 - front 1–6
 - keyboard 1–10
 - left side 1–8, 1–12
 - rear panel 1–8
 - right side 1–6, 1–10
 - top 1–12
- computer specifications 6–1
- configuration code 1–1

- connector pin assignments
 - external monitor connector A-4
 - microphone jack A-2
 - modem jack A-3
 - monitor connector A-4
 - network interface card (NIC) jack A-3
 - RJ-11 jack A-3
 - RJ-45 jack A-3
 - universal serial bus (USB) connector A-2
- connectors 4-2
- cursor control keys 1-11

D

- design overview 1-16
- disassembly sequence chart 5-3
- diskette drive
 - OS loading problems 2-15
- display
 - illustrated 3-2
 - installation 5-17
 - release latch 1-7
 - removal 5-15
 - spare part number 3-3, 5-15
 - specifications 6-3
- DMA specifications 6-7
- docking connector 1-9

- docking station
 - troubleshooting 2-10
- drives, preventing damage 4-3
- DVD-ROM drive
 - OS loading problems 2-16
- DVD-ROM drive (used with MEU), spare part number 3-9

E

- Easy Access buttons 1-12
- electrostatic damage
 - prevention 4-4
- electrostatic voltage levels 4-7
- embedded numeric keypad 1-11
- external monitor connector
 - location 1-9
 - pin assignments A-4
- external monitor connector cover, illustrated 3-6

F

- features 1-2
- feet
 - illustrated 3-6
 - removal 5-5
- front components 1-6
- function keys 1-11

G

- grounding equipment/methods 4-6

H

- hard drive
 - adapter (used with MEU),
 - spare part number 3-9
 - illustrated 3-4
 - light 1-13
 - location 1-7, 1-15
 - OS loading problems 2-12
 - spare part numbers 3-5
 - specifications 6-4
- headphone jack
 - location 1-7
 - pin assignments A-1
- hinge covers
 - illustrated 3-2, 3-6
 - removal 5-16

I

- I/O address specifications 6-9
- infrared port 1-9
- interrupt specifications 6-8

K

- keyboard
 - components 1-10
 - illustrated 3-2
 - removal 5-11
 - spare part numbers 3-3,
5-11
 - troubleshooting 2-20

L

- LED board
 - illustrated 3-2
 - removal 5-12
 - spare part number 3-3,
5-12

- LED board cable
 - illustrated 3-2, 3-7
 - removal 5-14

- LED cover
 - illustrated 3-2, 3-6
 - removal 5-9

- left side components 1-8

- Logo Kit, spare part number
3-9

M

- memory expansion board,
 - spare part number 3-5
- memory expansion
 - compartment cover
 - illustrated 3-2, 3-6
 - location 1-15
- memory map specifications
6-12
- microphone
 - illustrated 3-2, 3-7
 - jack
 - location 1-7
 - pin assignments A-2
 - location 1-13
 - removal 5-10
- mini PCI compartment cover
 - illustrated 3-2, 3-6
 - location 1-15
 - removal 5-7
- Miscellaneous Plastics Kit
 - illustrated 3-2, 3-6
 - spare part number 3-3, 3-6
- Mobile Expansion Unit
(MEU), spare part number
3-9

- modem
 - jack, pin assignments A-3
 - spare part number 3-9
 - troubleshooting 2-22
- modem adapter, spare part number 3-9
- modem cable adapter, spare part number 3-9
- modem cable, spare part number 3-9
- modem/network interface card (NIC)
 - illustrated 3-4
 - removal 5-6
 - spare part number 3-5, 5-6
- modem/network interface card (NIC) cable
 - illustrated 3-7
 - removal 5-29
- monitor connector
 - location 1-9
 - pin assignments A-4
- N**
- network interface card (NIC)
 - jack, pin assignments A-3
- network interface card (NIC)/modem
 - illustrated 3-4
 - removal 5-6
 - spare part number 3-5, 5-6
- network, troubleshooting 2-22

- nonfunctioning device,
 - troubleshooting 2-10, 2-19
- num lock light 1-12
- numeric keypad 1-11
- O**
- operating system loading,
 - troubleshooting 2-11
- P**
- packing precautions 4-4
- parts catalog 3-1
- password, clearing 1-3, 1-4
- PC Card
 - eject button 1-7
 - slot 1-7
 - slot weight saver,
 - illustrated 3-6
- PhoenixBIOS Setup Utility
 - 2-1
- plastic parts 4-2
- pointing device,
 - troubleshooting 2-21
- power
 - jack 1-7
 - light 1-13
 - switch 1-12
 - troubleshooting 2-4
- power cord
 - set requirements B-1
 - spare part number 3-8
- power management features
 - 1-5

R

real time clock (RTC) battery
 illustrated 3-4, 3-6
 removal 5-22
 spare part number 3-5,
 5-22

rear panel components 1-8

removal

 preliminaries 4-1
 procedures 4-1, 5-1

replacement

 preliminaries 4-1
 procedures 4-1, 5-1

right side components 1-6

RJ-11 jack

 location 1-9
 pin assignments A-3

RJ-11 P55 adapter, spare part
 number 3-9

RJ-11 PTT adapter, spare part
 number 3-9

RJ-45 jack

 location 1-9
 pin assignments A-3

S

Screw Kit, spare part number
 3-8, C-1

scroll lock light 1-13

security cable slot 1-7

serial number 1-15, 3-1, 5-2

service considerations 4-2

SKU number 1-1

speaker, location 1-15

specifications

 AC adapter 6-7

 battery 6-6

 computer 6-1

 display 6-3

 DMA 6-7

 hard drive 6-4

 I/O addresses 6-9

 interrupts 6-8

 memory map 6-12

Standby button 1-13

static shielding materials 4-7

stereo speaker jack

 location 1-7

 pin assignments A-1

system board

 illustrated 3-4

 removal 5-24

 spare part number 3-5,
 5-24

system memory map 6-12

T

tools required 4-1

top components 1-12

top cover

 illustrated 3-4

 removal 5-18

 spare part number 3-5,
 5-18

TouchPad

 button, location 1-13

 cable

 disconnection 5-21

 illustrated 3-6, 3-7

 location 1-13

- transporting precautions 4–4
- troubleshooting
 - audio 2–17
 - docking station 2–10
 - flowcharts 2–2
 - keyboard 2–20
 - modem 2–22
 - network 2–22
 - nonfunctioning device
 - 2–10, 2–19
 - operating system loading
 - 2–11
 - overview 2–1
 - pointing device 2–21
 - power 2–4
 - video 2–8

U

- universal serial bus (USB)
 - connector
 - location 1–9
 - pin assignments A–2

V

- vents 1–9, 1–15
- video troubleshooting 2–8

W

- Windows application key
 - 1–11
- Windows logo key 1–11
- workstation precautions 4–5