

# CRIMESTOPPER

## SP-200

### REMOTE CONTROL ALARM SYSTEM INSTALLATION INSTRUCTIONS

---

#### INTRODUCTION

**CONGRATULATIONS** on your choice of an Alarm System by Crimestopper Security Products Inc. This booklet contains the information necessary for installing, using, and maintaining your alarm system. If any questions arise, contact your installation dealer or Crimestopper Security Products Inc. at the Tech Support number below.

**\*IMPORTANT INFORMATION: Primary and Optional Features:**

**-PRIMARY:** These are features that must be connected in order for the system to operate properly; i.e. the Siren, L.E.D., +12V Power, Ground, Door pin, Flashing lights Override/Program/Valet Button etc.

**-OPTIONAL:** These are features to be connected if desired or agreed upon by the installing dealer. These features may also require additional parts and/or labor fees. Consult with your installer beforehand; i.e. Door Locks, Starter disable, Hood/Trunk trigger, and Auxiliary Remote Outputs etc.

***This installation book is designed for the installer or individual with an existing understanding of automotive electrical systems, along with the ability to test and connect wires for proper operation. To ease installation, we suggest that you READ THIS MANUAL before beginning your installation. This book is provided as a GENERAL GUIDLINE and the information contained herein may differ from your vehicle.***

**TECH SUPPORT**  
**Mon-Fri 8:00 AM-4:30 PM Pacific Time**  
**(800) 998-6880**

**REV. 12-2008**

This device complies with FCC Rules part 15. Operation is subject to the following two conditions: 1) This device may not cause interference, and (2) this device must accept any interference that may be received, including interference that may cause undesired operation. The manufacturer is not responsible for any radio or TV interference caused by unauthorized modification to this equipment. Such modification could void the user's authority to operate the equipment.

# TABLE OF CONTENTS

<i>Pre-Installation Considerations.....</i>	<i>2</i>
<i>Cautions &amp; Warning.....</i>	<i>3</i>
<i>Component Mounting.....</i>	<i>3</i>
<i>Wiring.....</i>	<i>4-5</i>
<i>SHOCK SENSOR Wiring.....</i>	<i>6</i>
<i>LED and Valet Switch Wiring.....</i>	<i>7</i>
<i>Power Door Lock Wiring.....</i>	<i>7-8</i>
<i>Transmitter Programming.....</i>	<i>9</i>
<i>Option Programming.....</i>	<i>10-13</i>
<i>Starter Kill Diagram.....</i>	<i>14</i>
<i>Wiring Diagram.....</i>	<i>15</i>
<i>Data Port Diagram .....</i>	<i>16</i>

## PRE-INSTALLATION CONSIDERATIONS

**BEFORE BEGINNING**, check all vehicle manufacturer cautions and warnings regarding electrical service (AIR BAGS, ABS BRAKES, ENGINE / BODY COMPUTER AND BATTERY).

**PLAN OUT YOUR INSTALLATION.** You should pre-determine the location of the Control Module (Brain), Valet button, LED, and Siren locations. This will save time and ease the installation process.

**USE VOLT/OHM METER** to test and locate all connections. Test Lights or Lighted Probes could possibly damage a vehicle's computer system or cause an airbag to deploy.

**ADDITIONAL PARTS**, that are not included with this unit, may be needed for your particular vehicle. These items may include extra relays, Door Lock Interface Modules, or Transponder Override modules.

## CAUTIONS & WARNINGS

***DAMAGE RESULTING FROM IMPROPER INSTALLATION IS NOT COVERED UNDER WARRANTY!!***

**DO NOT** remote start your vehicle in a closed garage. Make sure that the garage door is open or there is adequate ventilation. Failure to observe this rule could result in injury or death from poisonous Carbon Monoxide fumes.

**DO NOT ROUTE ANY WIRING THAT MAY BECOME ENTANGLED** with the brake/gas pedals, steering column, or any other moving parts in the vehicle.

**REMOVE MAIN SYSTEM FUSE(S)** before jump-starting the vehicle or charging the battery at high boost. **DAMAGE MAY OCCUR TO SYSTEM IF PROPER PRECAUTIONS ARE NOT OBSERVED.**

**DO NOT** exceed the rated output current of any circuit on the Remote start module. Failure to observe this warning will result in damage to the unit. Output currents are listed where applicable throughout this manual.

**DO NOT** extend the Remote start ignition harness length. Mount the module so that main harness reaches all ignition switch wiring. Extending these wires could result in poor performance.

## COMPONENT MOUNTING

**CONTROL MODULE:** The alarm control module should be mounted in a concealed location. **DO NOT** mount the control unit in the engine compartment. Fasten the module to a bracket or wire harness using the cable ties provided.

**ANTENNA MODULE:** For optimum range and performance, the antenna/receiver module should be located high up on the front windshield glass. For example: behind the rearview mirror. Note: Window tints or Films may decrease the range of the system. The mounting surface for the antenna should be clean and dry.

**SIREN MOUNTING:** Mount the siren under the hood to fender-well or other body surface with the open end facing downward. Run the red siren wire through the firewall using a rubber grommet. Ground the black wire to the body metal near the siren.

**LED:** Mount the Status LED in a visible location on the dashboard or console.

**SHOCK SENSOR:** Mount the included shock sensor with wire ties to an under dash wire harness or fasten with screws to firewall or side paneling.

**VALET/OVERRIDE/PROGRAM BUTTON:** Mount the Override/Program push-button in a hidden but accessible location. This button is required for emergency disarm, programming, and valet mode.

# WIRING

## **GREEN WIRE: (-) NEGATIVE DOOR TRIGGER**

Identify the wire that reads ground when any door is open and 12 volts when all doors are closed. Some vehicles may have isolated door triggers. In this case you may need to run additional wires from other doors or go directly to the wire that triggers the vehicle's interior dome light. Sometimes newer vehicles contain a separate body control module (BCM) where the door trigger circuit can be located. One vehicle will not require the use of BOTH Negative and Positive door trigger wires.

## **VIOLET WIRE: (+) POSITIVE DOOR TRIGGER**

Same as the GREEN wire above except this wire is used for vehicles that show a positive voltage (12 volts) when the door is open and a ground when doors are closed as in many Ford, Lincoln, and Mercury vehicles.

## **BLACK WIRE: SYSTEM CHASSIS GROUND**

The Black wire **MUST** be connected to the CHASSIS METAL of the vehicle. Scrape away any paint or debris from the connection point and use a star washer to ensure a good connection. Keep the ground wire short.

## **YELLOW WIRE: IGNITION SWITCHED "ON" AND "START" +12 VOLTS**

Connect to an IGNITION wire (or fuse in the fuse box) that shows +12 Volts when the key is in both "On" and "Start" (WHEN CRANKING) positions.

## **GRAY WIRE: (-) NEGATIVE AUX REMOTE OUTPUT 1 (Optional, may require a relay)**

Connect to the Negative trunk release circuit or to the activation circuit of an auxiliary module or device. If the circuit requires +12V, then a relay is required. RELAY WIRING: Connect the Gray wire to terminal 85, connect relay terminals 86 and 87 to +12V constant power. Connect terminal 30 of the relay to the +12V positive device/circuit to be activated.

## **BLUE WIRE: (-) NEGATIVE HOOD/TRUNK TRIGGER (Optional)**

Input trigger for a grounding hood or trunk pin switch. Connect to existing hood and trunk pin switches that read ground when open. If no existing switches are available, install new pin switches if desired. Note: DO NOT mount new pin switches in water pathways.

## WIRING

### **BLACK/WHITE WIRE: (-) NEGATIVE DOME LIGHT ILLUMINATION OUTPUT (Optional, requires a relay)**

This wire provides a (-) negative ground when the system is disarmed to activate a vehicles dome light circuit. We recommend the use of a relay for this connection. Connect Black/White to terminal #85 of relay. Connect terminal #86 to fused constant +12V. Connect terminal #87 to a +12V constant or ground source depending on the type of dome light circuit in the vehicle. Connect Terminal #30 to the dome light circuit in the vehicle.

### **BROWN/WHITE WIRE: (-) NEGATIVE HORN PULSE / CHIRP OUTPUT (Optional, may require a relay)**

Connect to the Negative Horn Trigger wire usually located near the steering column. If the vehicle horn circuit requires +12V, then a relay is required.

### **WHITE/RED WIRE: (-) NEGATIVE AUX REMOTE OUTPUT 2 (Optional, may require a relay)**

This wire connects the same way as Remote Output 1 see GRAY WIRE description above.

### **BROWN WIRE: (+) SIREN OUTPUT (3 Amp Max.)**

Connect to RED siren wire from the Siren in the engine compartment.

### **WHITE WIRE: +12V FLASHING PARKING LIGHT OUTPUT**

Connect to the switched parking light wire at back of light switch. If this is not possible, connect directly to one of the parking lights at the front of the vehicle. European vehicles require separate right and left circuits. Use a dual relay or 2 diodes to separate the output signal.

### **RED WIRE: +12V POWER INPUT (15 amp fuse)**

Connect to +12 Volt source with supplied fuse & holder. Recommended location for this connection is at the vehicle battery positive terminal.

# WIRING: 4-PIN Shock Sensor (26 Gauge wires)

## Sensor Adjustment

Adjust the main shock sensor with the small White dial. Clockwise will increase sensitivity and counter-clockwise will decrease sensitivity. Adjust Pre-Warning level with small Black dial.

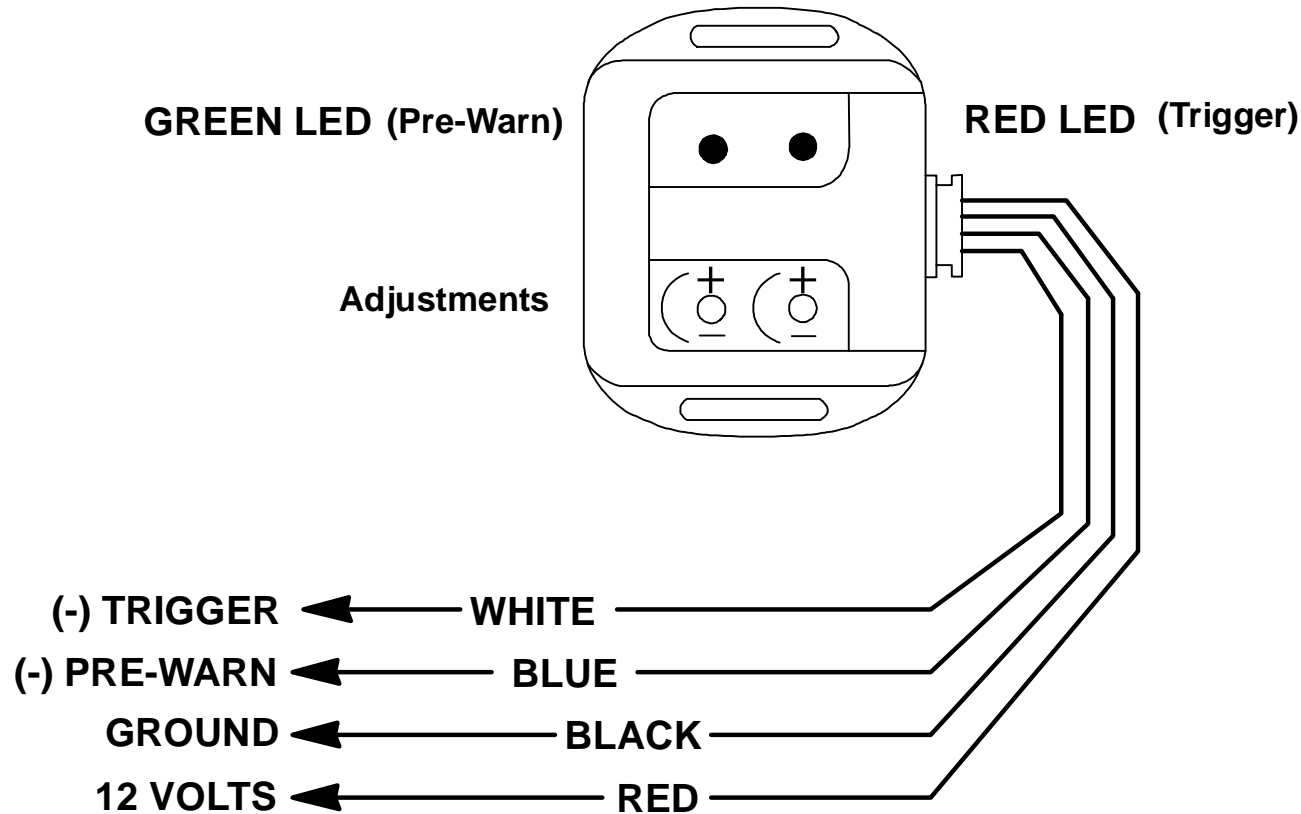

**SHOCK SENSOR:** The sensor supplied with this system does not require any additional wiring. Simply mount the sensor in a suitable location, plug it in, and adjust for sensitivity.

## WIRING: 2-PIN LED / 2-PIN Program-Valet Button (26 gauge wires)

Mount Status LED in a visible location on the Dash or Console. Connect the small 2-pin plug from the LED to the control module. Note: Connectors are designed so that they will only plug into their appropriate slots.

Mount the Valet/Program/Override button in a suitable location. Connect the 2-pin plug from the Switch to the control module. Note: Connectors are designed so that they will only plug into their appropriate slots.

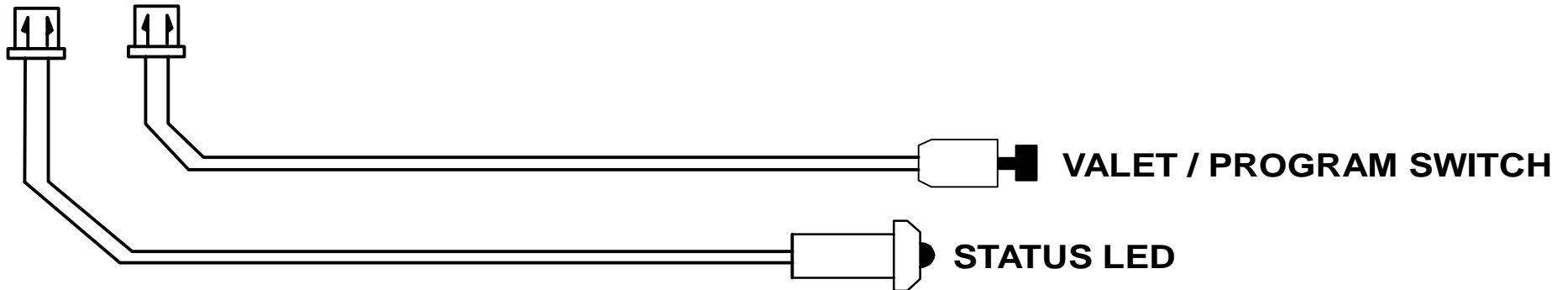

## POWER DOOR LOCK WIRING

### 3 PIN DOOR LOCK PLUG (Optional):

**GREEN:** (-) Negative pulse for LOCK

**RED:** +12V Coil Power for using relays.

**BLUE:** (-) Negative pulse for UNLOCK

**Hint:** Determine the type of locking system the vehicle has before connecting any wires. Incorrect connection could result in damage to the alarm and/or the vehicle's locking system. Some vehicles are equipped with Class 2 DATA door locks systems which require a bypass module to control the door locks. Please refer to vehicle wiring color chart which is supplied via TechWeb (basic service) for authorized dealers.

# POWER DOOR LOCK WIRING

## NEGATIVE TRIGGER DOORLOCK WIRING

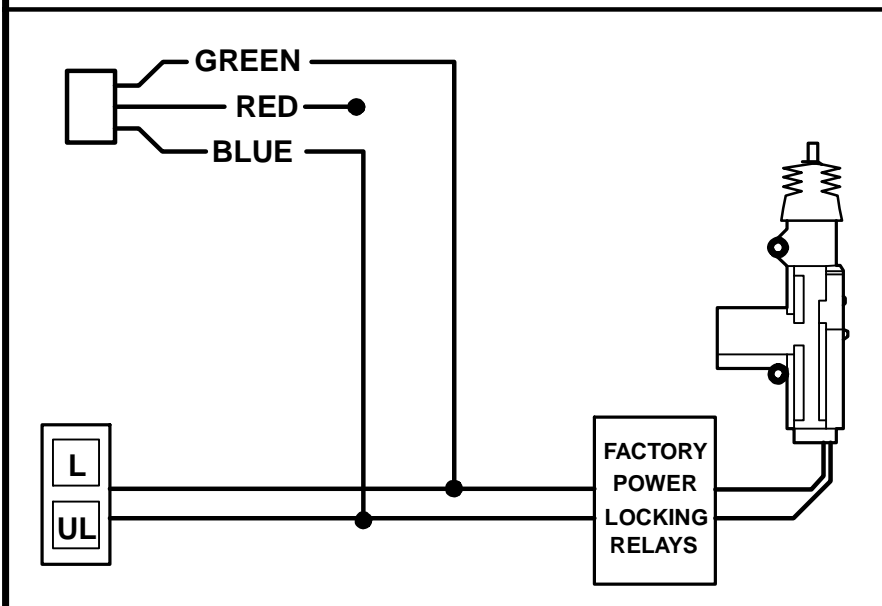

## POSITIVE TRIGGER DOORLOCK WIRING

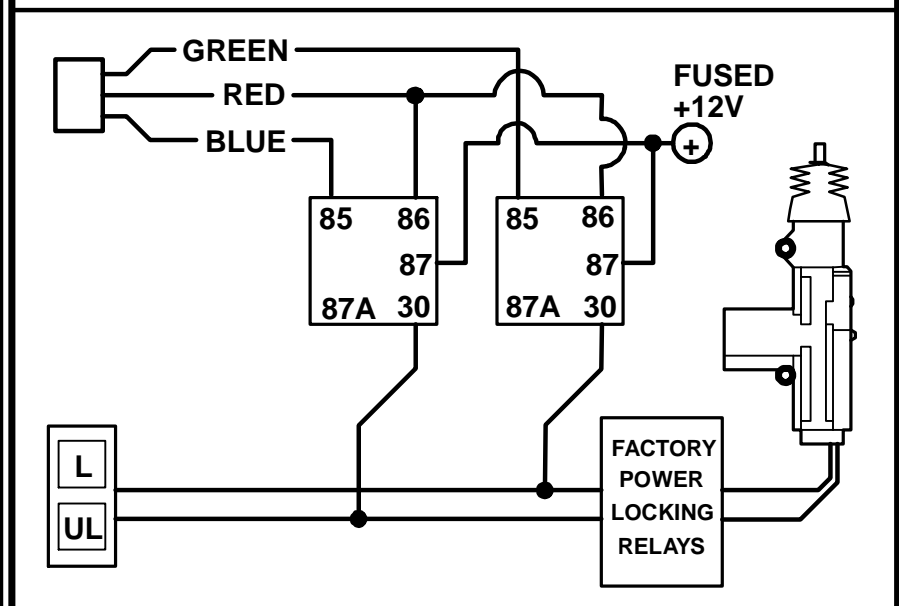

## REVERSE POLARITY DOOR LOCK WIRING

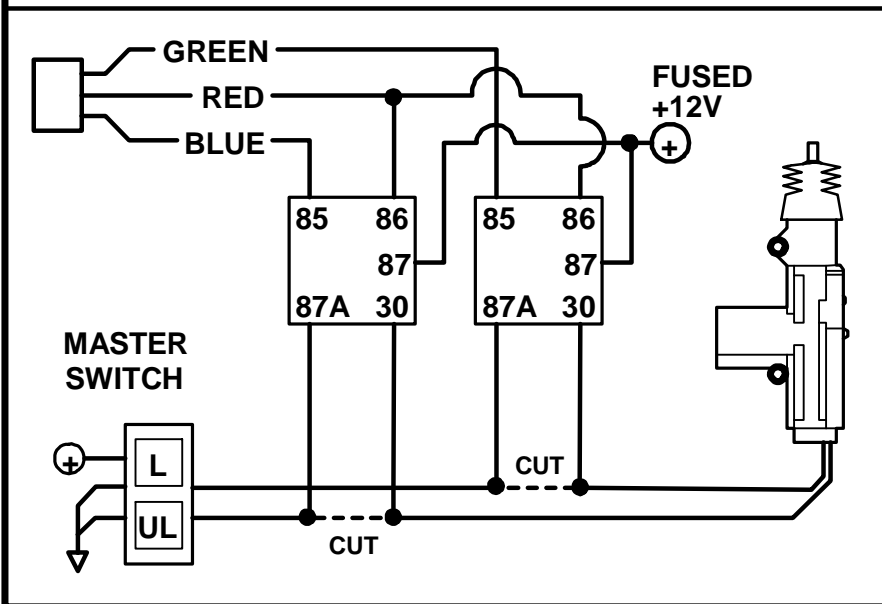

## AFTERMARKET MOTOR/DOOR LOCK WIRING

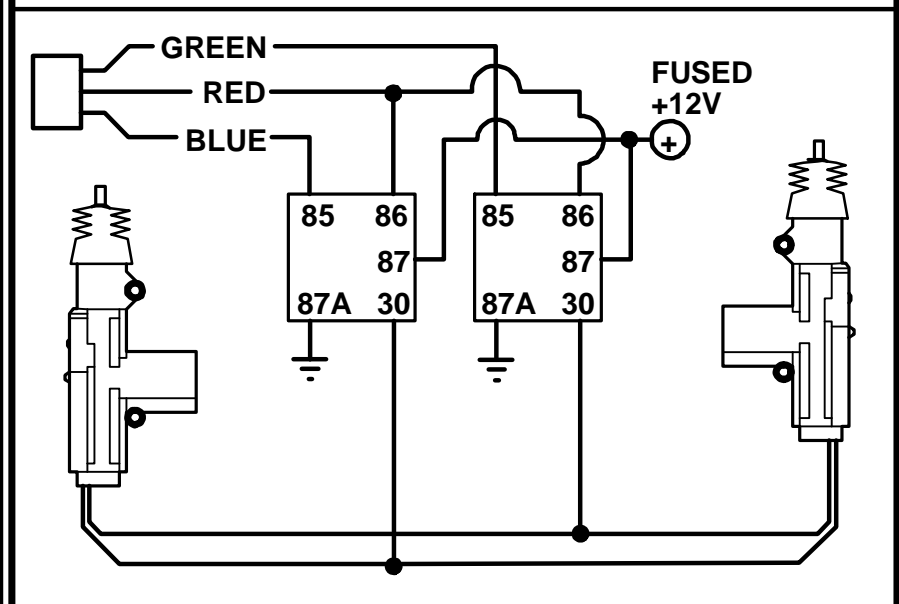



# TRANSMITTER PROGRAMMING

NOTE: All transmitters must be learned at the time of programming. This system can learn up to 4 remotes.

1. Turn key to the ON position and press program button 4 times.
2. After a short delay, the unit will flash the parking lights 4 times, Siren 4 times, Horn 4 times and status LED will be on solid.
3. Press the Button #1 (Lock) on the remote you wish to program.
4. You should get 2 light flashes, 2 siren chirps and 2 horn honks (optional) indicating the unit is waiting for the second code to learn. Press button #1 and #2 together of a second transmitter, the unit will flash 3 times, 3 siren chirps and 3 horn honks. Press the lock and unlock button on a 3<sup>rd</sup> or 4<sup>th</sup> transmitter for up to 4 total. Note: The unit will not flash the lights when learning the 4<sup>th</sup> code. Turn key off to exit programming mode.

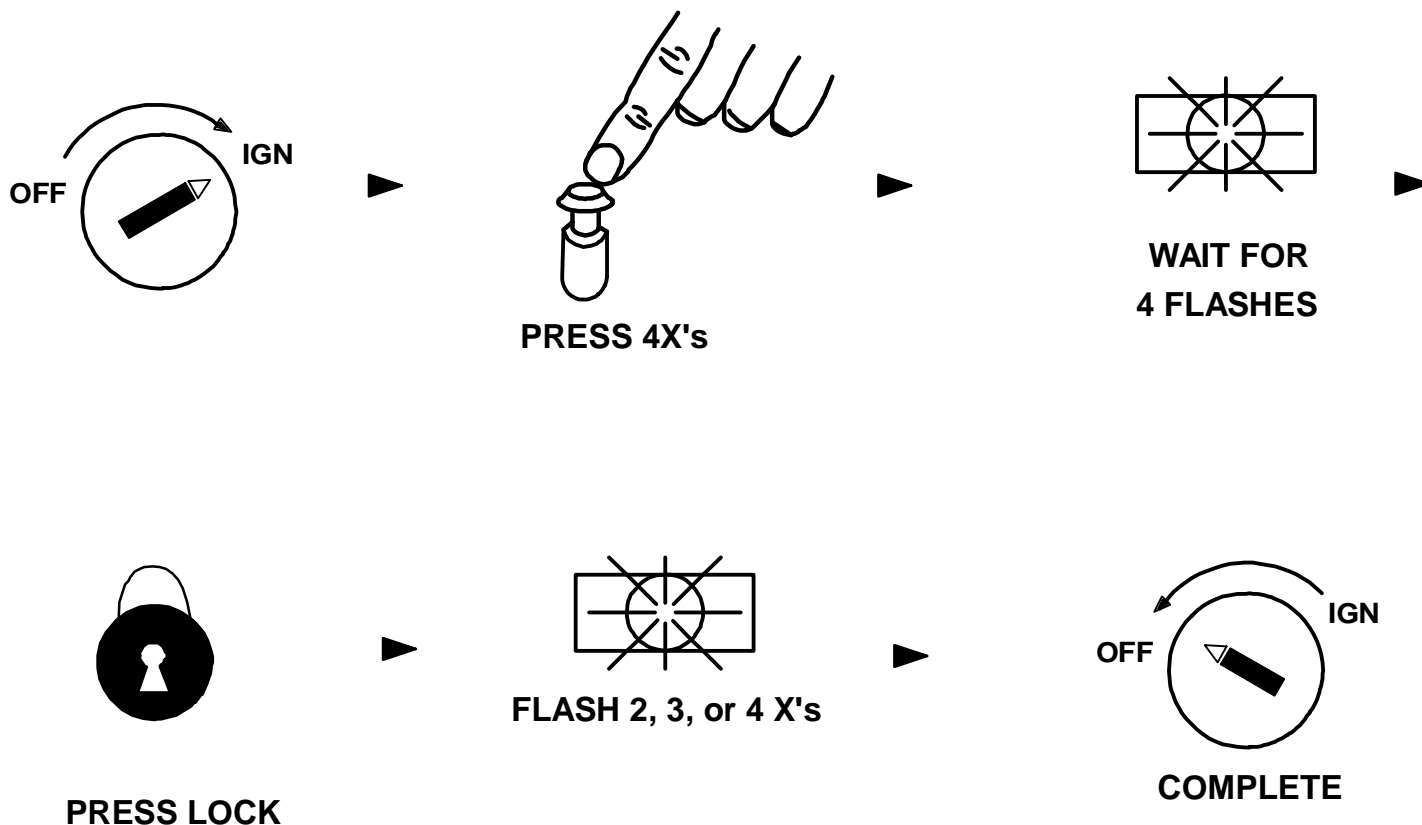

# OPTION PROGRAMMING

1. Turn the Ignition ON and press the Override/Program button 5 times.
2. After a short delay, the parking lights will flash 5 times, Siren 5 times, Horn 5 times and status LED will be on solid.
3. Within the next few seconds, press the Override/Program button [again] the number of times that corresponds to the options chart below. Siren and/or optional horn should chirp for each press.
4. When you get to the desired option number, quickly press the appropriate button on the remote control according to the chart below. The system will provide 1 chirp/flash for Button 1 (Lock Symbol) and 2 chirps/flashes for button 2, 3 for Button #3 and 4 for button #4. (See Chart below for option descriptions and values.)
5. Turn Ignition off. System chirps and flashes the lights 3 times on exit. When you are finished customizing options, check operation.

## PROGRAMMING OPTIONS CHART

\* = Default Setting

Option #	Option Description	BUTTON 1 LOCK	BUTTON 2 UNLOCK	BUTTON 3 AUX	BUTTON 4 SILENT
1.	Factory Horn Chirps / Pulses	Pulse with trip only	Arm/Disarm Chirps & Pulse with trip	*Arm/Disarm/Warn Chirp & Pulse w/ trip *	
2.	Passive Arming ON & OFF Passive Chirp Countdown	Ignition & Last Door	*OFF*	Ignition & Last Door w/ Chirp Countdown	Last Door Only
3.	Passive Lock / Cust. Override	ON	*OFF*	Custom Override	
4.	Ignition controlled Locks	*ON*	OFF	Ignition Lock Only	
5.	5/60 Sec. Door Open Warning	5 Seconds	*60 Seconds*		
6.	Active Re-Arm (30 Sec.)	*ON*	OFF		
7.	Double Unlock Pulse	*OFF*	ON		
8.	Silent Arm/Disarm (Chirp Defeat w/button 1 or 2)	*OFF*	ON		
9.	Parking Lights on with disarm	*ON*	OFF		
10.	Disarm with trunk pop	OFF	*ON*		
11.	N/A	N/A	N/A		
12.	Door Lock Pulse Time	*0.7 Sec.*	3 Sec.		
13.	Type of Carjack Protection	*ACTIVE*	PASSIVE	FULL-TIME	
14.	Carjack Enable/Disable	*Disable*	Enable		
15.	L/UL or Arm/Disarm w/IGN ON	*Lock/Unlock *	Arm/Disarm		
16.	<b>Data Port Protocol</b> 1-Way = OFA, 2-Way = SL	<b>*2-Way*</b>	<b>1-Way</b>		

# OPTION PROGRAMMING

**NOTE: Options can be instantly restored to Factory Default Values.**

**To restore default values:**

**Perform step #1 (See page 10), then press button 3 (trunk). The siren and horn will chirp 4 times and lights will flash 4 times. Turn OFF Ignition. All programming options will be restored to \* Default \* values (See page 10).**

## **1. HORN CHIRPS / PULSES**

This option controls the system's Factory Vehicle Horn output. There are 3 selections: Button 1 (Lock) = Horn Pulse only when alarm is tripped. Button 2 (Unlock) = Horn Chirps for Arm / Disarm and Pulse when tripped. Button 3 (Trunk) = Horn Chirps for Arm, Disarm, and Pre-warning protection. All settings provide horn pulses when triggered.

## **2. PASSIVE ARMING / CHIRP COUNTDOWN**

This option controls the Passive (Automatic) Arming feature. If ON, arming will occur 30 Seconds after the ignition is turned off and the last door has been closed. The LED will begin flashing rapidly while counting down. If a door is reopened, the system will wait (LED OFF) for the door or zone to close before arming. The unit will chirp once and flash the lights once. Doors will lock if passive locking is selected. Factory default setting is OFF. If Passive Chirp countdown is selected, the System will produce a siren chirp every 2 seconds during countdown until the system arms.

## **3. PASSIVE LOCKS / CUSTOM OVERRRIDE**

**PASSIVE LOCKS:** This option controls whether the doors will lock when Passive Arming occurs. Note: May increase the risk of locking keys in the vehicle. When selected ON the alarm will passively lock the doors when passive arming.

## **4. IGNITION-CONTROLLED LOCKS**

This option controls whether the locks are controlled by Ignition. There are 3 selections: Button 1 (Lock) = Lock/Unlock with vehicle Ignition. Button 2 (Unlock) = No ignition locks. Button 3 (Trunk) = Ignition lock only. *Doors will not lock if they are open to prevent locking the keys in.*

## **5. DOOR OPEN WARNING (5 or 60 Seconds)**

This setting changes the delay time in which the alarm system begins to monitor the Door circuit. This option can prevent the alarm from giving warning chirps on vehicles with a delayed dome light.

# OPTION PROGRAMMING

## **6. ACTIVE RE-ARMING**

Active Re-arming allows the system to re-arm itself 30 seconds after disarmed with the transmitter if a door has not been opened. This is handy if the vehicle is accidentally disarmed (via the Transmitter in your pocket) without you knowing it. Note: Active re-arm is reset by dome light illumination. If you are using dome light illumination, active re-arm will not function.

## **7. DOUBLE UNLOCK PULSE**

With this feature enabled, the unit will send 2 unlock pulses when the #2 Unlock button is pressed. 2 pulses are required for interfacing into some existing Factory Keyless Entry or Alarm systems on vehicles such as Nissan, VW, Toyota, and Lexus vehicles.

## **8. SILENT ARMING /DISARMING (CHIRP DEFEAT)**

With this feature, the system can be Arm and Disarm without the siren chirp using button #1 & #2. Flashing parking lights will be the only Arm/Disarm confirmation.

## **9. PARKING LIGHTS ON WITH DISARM**

Keeps parking lights on instead of 2 flashes when system is disarmed to assist in locating your vehicle in a crowded parking lot or structure. Light will stay on for 30 Sec. or until Ignition is turned on.

## **10. DISARM WITH AUX. OUTPUT 1 (TRUNK POP)**

Controls whether the system will or will not DISARM when the trunk pop or AUX. feature is used. When the feature is turned on the unit will DISARM when opening trunk or using an auxiliary device controlled by the Gray output wire.

## **11. N/A, NO OPTION**

## **12. DOOR LOCK/UNLOCK PULSE TIME**

Controls the amount of time (0.75 sec. or 3 sec.) for the lock/unlock pulse. The 3 sec. setting may be required for 1980'/90's European Vehicles that require a long pulse to do Vacuum door lock systems.

## **13. ACTIVE, PASSIVE, or FULL-TIME CARJACK PROTECTION**

This feature controls the type of Carjack protection the alarm will provide. There are 3 selections: Button 1 (Lock) = Active protection. Button 2 (Unlock) = Passive protection. Button 3 (Trunk) = Full-Time protection. Option number 14 must be enabled to allow Carjack functions to operate. See Carjack Protection features.

## OPTION PROGRAMMING Cont.

### **14. CARJACK FEATURES**

This option controls the unit's Car Jack features. Enable or Disable Carjack (Turn ON or OFF) with this option.

### **15. Lock/Unlock or Arm/Disarm with Ignition ON**

This option allows you Arm and Disarm the system with the Ignition ON. This is used when there is a remote starter added to the system. The default is lock/unlock without arm and disarm while the ignition on.

### **16. Data Port Protocol:**

This option controls the Data Port Protocol for 1-Way (OFA modules) or 2-Way (SL modules). The default is set for 2-Way Protocol. This option has no effect on conventional wiring of Bypass modules.

### **Data bus Systems: Data Controlled door locks, Factory Security and many accessories**

This unit includes DP Technology it will allow you to plug our modules which operate Data control Door locks, accessories, and Bypass Factory security systems directly into the unit by via Data Port. The module cable plugs directly to the Data port on the side of the unit. Please refer to Databus module manual for detail instructions.

Option #16 controls the Data Port Protocol for 1-Way (OFA modules) or 2-Way (SL modules). The default is set for 2-Way Protocol. This option has no effect on conventional wiring of Bypass modules.

# STARTER KILL DIAGRAM

Locate the vehicle starter solenoid or relay wiring. Wire up as shown below.

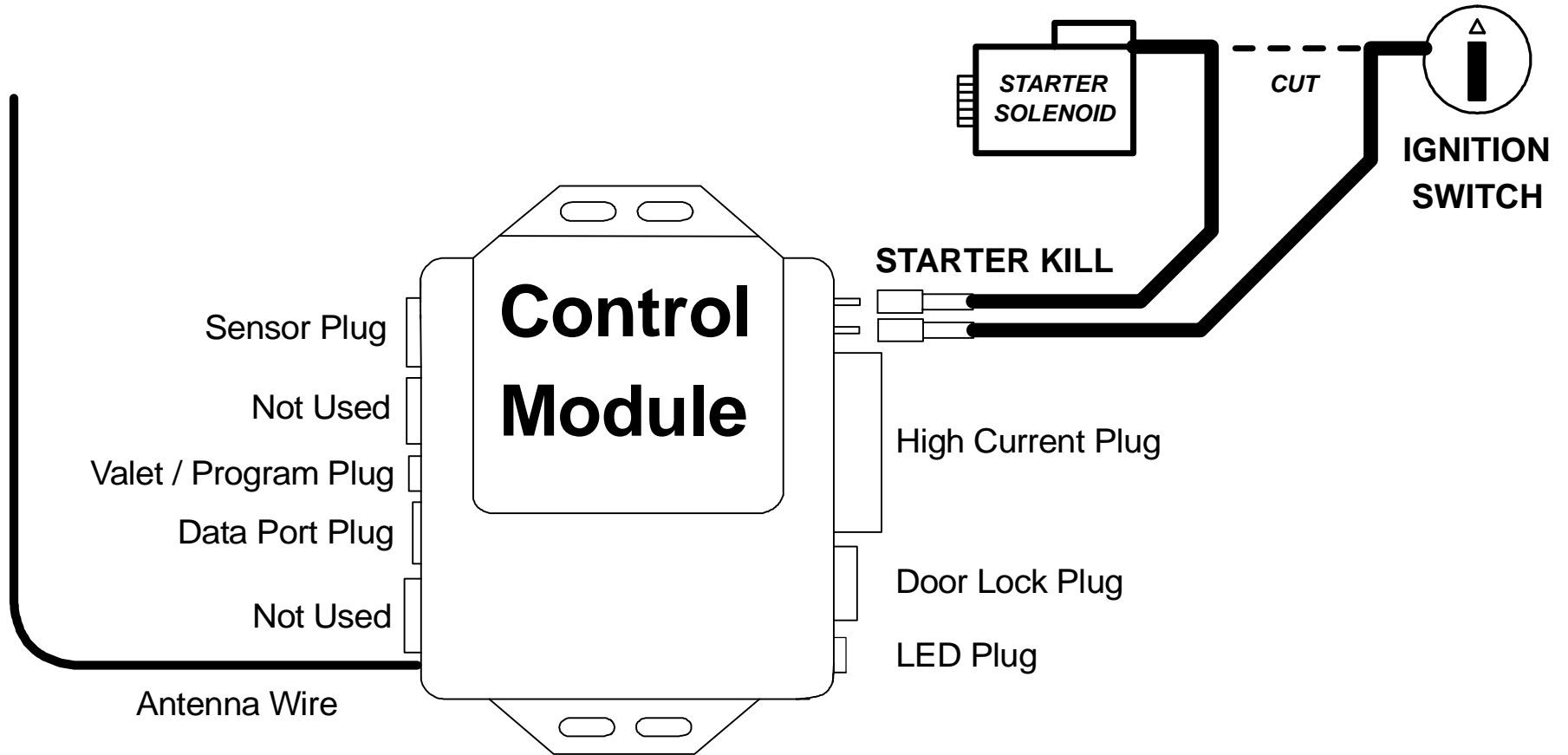

# WIRING DIAGRAM

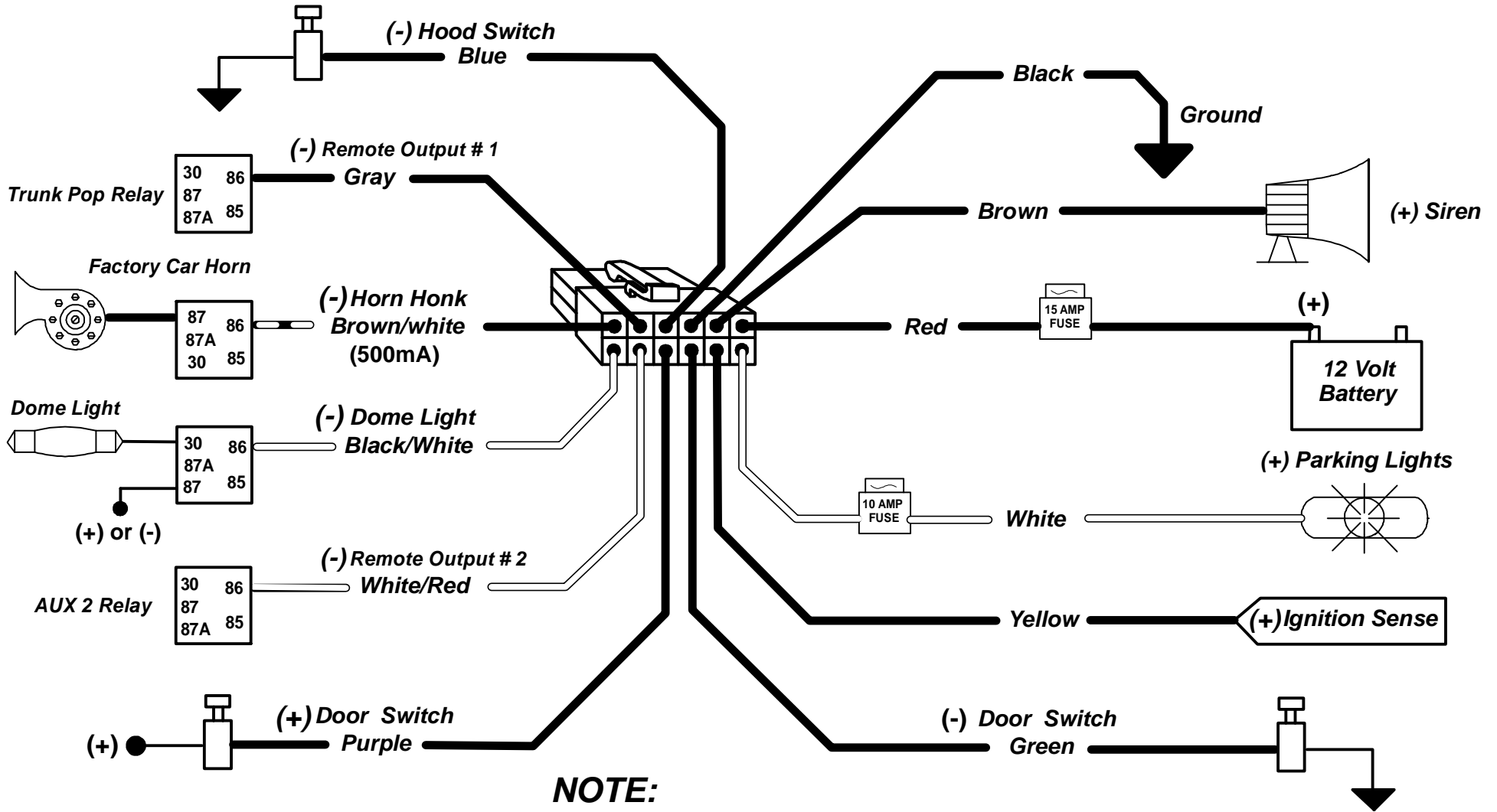

**NOTE:**  
All (-) Outputs are 500mA

# DATA PORT DIAGRAM

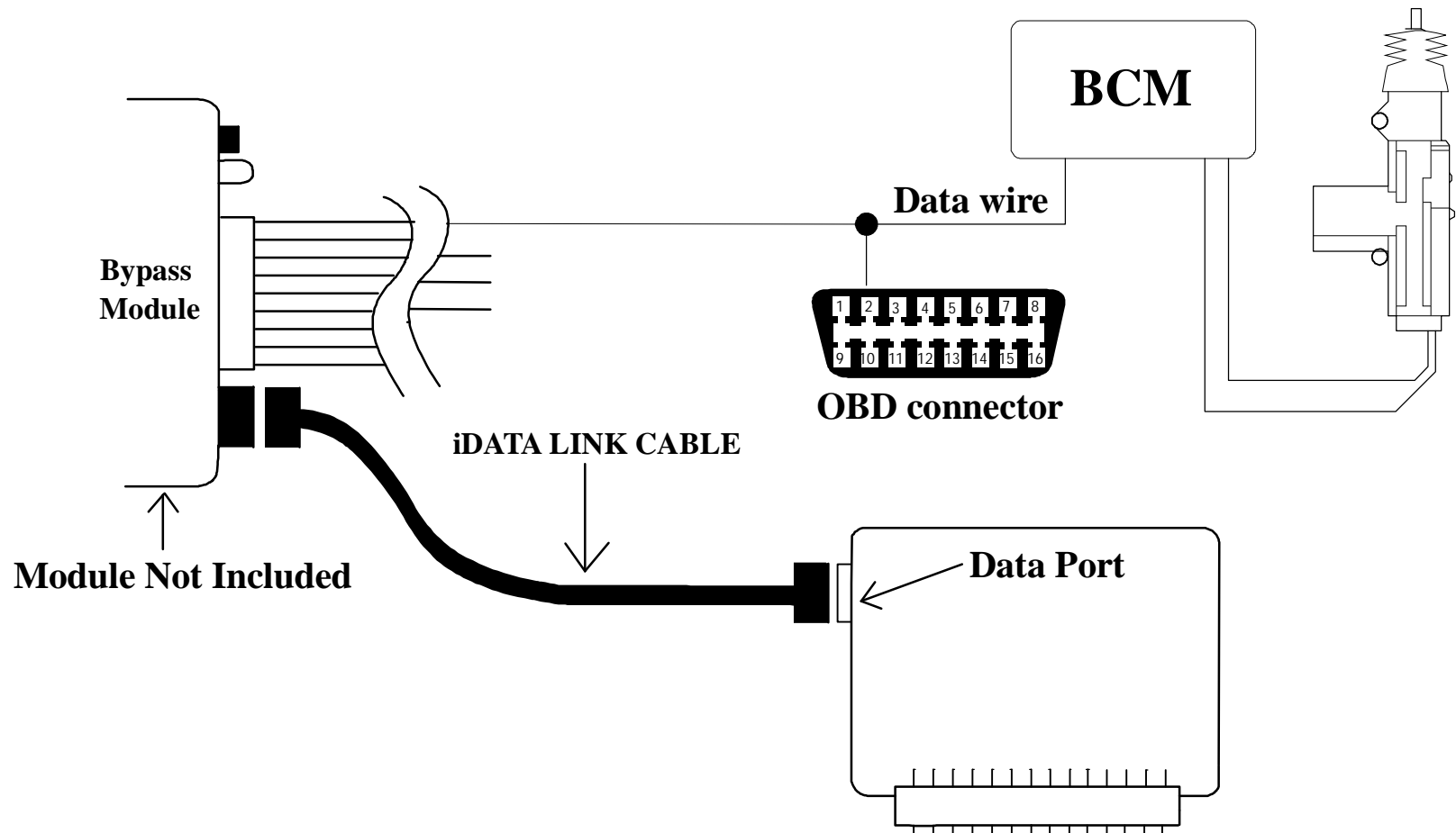

**CRIMESTOPPER**

Phone (800) 998-6880  
FAX (805) 581-9500

© 2008 Crimestopper Security Products

**TechWeb**

ONLINE TECHNICAL SUPPORT  
[www.crimestopper.com](http://www.crimestopper.com)