

BUNN®

JDF-4

S/N 0005473 & UP

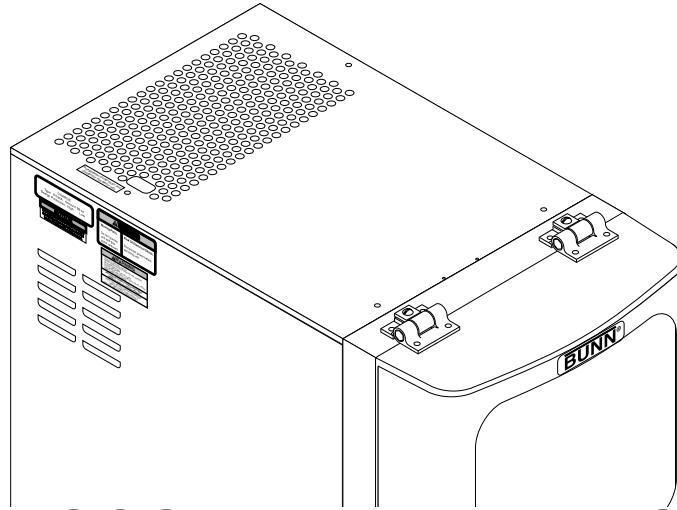

DISCONTINUED VERSION
The information in this manual
is no longer current.

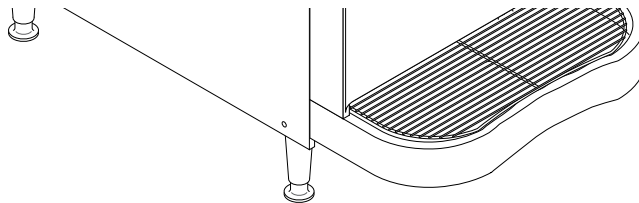

INSTALLATION & OPERATING MANUAL

BUNN-O-MATIC CORPORATION

POST OFFICE BOX 3227

SPRINGFIELD, ILLINOIS 62708-3227

PHONE: (217) 529-6601 FAX: (217) 529-6644

To ensure you have the latest revision of the manual or to obtain the illustrated parts catalog, please visit the Bunn-O-Matic website, at www.bunn.com. This is absolutely FREE, and the quickest way to obtain the latest catalog and manual updates. Contact Bunn-O-Matic Corporation at 1-800-286-6070 to obtain a paper copy of the required Illustrated Parts Catalog mailed via U.S. Postal Service.

BUNN-O-MATIC COMMERCIAL PRODUCT WARRANTY

Bunn-O-Matic Corp. ("BUNN") warrants equipment manufactured by it as follows:

- 1) All equipment other than as specified below: 2 years parts and 1 year labor.
- 2) Electronic circuit and/or control boards: parts and labor for 3 years.
- 3) Compressors on refrigeration equipment: 5 years parts and 1 year labor.
- 4) Grinding burrs on coffee grinding equipment to grind coffee to meet original factory screen sieve analysis: parts and labor for 3 years or 30,000 pounds of coffee, whichever comes first.

These warranty periods run from the date of installation BUNN warrants that the equipment manufactured by it will be commercially free of defects in material and workmanship existing at the time of manufacture and appearing within the applicable warranty period. This warranty does not apply to any equipment, component or part that was not manufactured by BUNN or that, in BUNN's judgment, has been affected by misuse, neglect, alteration, improper installation or operation, improper maintenance or repair, damage or casualty. This warranty is conditioned on the Buyer 1) giving BUNN prompt notice of any claim to be made under this warranty by telephone at (217) 529-6601 or by writing to Post Office Box 3227, Springfield, Illinois 62708-3227; 2) if requested by BUNN, shipping the defective equipment prepaid to an authorized BUNN service location; and 3) receiving prior authorization from BUNN that the defective equipment is under warranty.

THE FOREGOING WARRANTY IS EXCLUSIVE AND IS IN LIEU OF ANY OTHER WARRANTY, WRITTEN OR ORAL, EXPRESS OR IMPLIED, INCLUDING, BUT NOT LIMITED TO, ANY IMPLIED WARRANTY OF EITHER MERCHANTABILITY OR FITNESS FOR A PARTICULAR PURPOSE. The agents, dealers or employees of BUNN are not authorized to make modifications to this warranty or to make additional warranties that are binding on BUNN. Accordingly, statements by such individuals, whether oral or written, do not constitute warranties and should not be relied upon.

If BUNN determines in its sole discretion that the equipment does not conform to the warranty, BUNN, at its exclusive option while the equipment is under warranty, shall either 1) provide at no charge replacement parts and/or labor (during the applicable parts and labor warranty periods specified above) to repair the defective components, provided that this repair is done by a BUNN Authorized Service Representative; or 2) shall replace the equipment or refund the purchase price for the equipment.

THE BUYER'S REMEDY AGAINST BUNN FOR THE BREACH OF ANY OBLIGATION ARISING OUT OF THE SALE OF THIS EQUIPMENT, WHETHER DERIVED FROM WARRANTY OR OTHERWISE, SHALL BE LIMITED, AT BUNN'S SOLE OPTION AS SPECIFIED HEREIN, TO REPAIR, REPLACEMENT OR REFUND.

In no event shall BUNN be liable for any other damage or loss, including, but not limited to, lost profits, lost sales, loss of use of equipment, claims of Buyer's customers, cost of capital, cost of down time, cost of substitute equipment, facilities or services, or any other special, incidental or consequential damages.

BrewWISE, BUNN Gourmet Ice, BUNN Pour-O-Matic, BUNN, Bunn-OMatic, Bunn-O-Matic, BUNNlink, BUNNserve, BUNN Espresso, DBC, Dr. Brew, Dual, EasyClear, EasyGard, Easy Pour, FlavorGard, Gourmet Ice, Gourmet Juice, High Intensity, IMIX, Infusion Series, Legendary for Quality, The Mark of Quality in Beverage Equipment Worldwide, My Café, Power-Logic, Safety-Fresh, Scale-Pro, Single, Smart Funnel, Smart Hopper, Soft Heat, SplashGard, System III, ThermoFresh, 392, AXIOM, Beverage Profit Calculator, Beverage Bar Creator, BrewLOGIC, BrewMETER, BrewWIZARD, BUNNSERVE, BUNNsource, Coffee At Its Best, Cool Froth, Digital Brewer Control, Intellisteam, Nothing Brews Like a BUNN, Pouring Profits, Pulse Wave, Quality Beverage Equipment Worldwide, Signature Series, Silver Series, Smart Heat, SmartWAVE, Tea At Its Best, The Horizontal Red Line, Titan, Ultra, are either trademarks or registered trademarks of Bunn-O-Matic Corporation.

CONTENTS

Warranty	2
Introduction	3
User Notices	3
Initial Set-Up & Electrical Requirements	4
CE Requirements	4
Plumbing Requirements	5
Plumbing Hook-Up	5
Operating Controls	6
Initial Fill	8
Dispenser Use	9
Cleaning	10
Adjustments & Optional Settings	13
Function Lists	18
Troubleshooting	21
Coolant Diagram	28
Schematic Wiring Diagram	29

USER NOTICES

Carefully read and follow all notices on the equipment and in this manual. They were written for your protection. All notices are to be kept in good condition. Replace any unreadable or damaged labels.

CAUTION

MAXIMUM RINSE WATER TEMPERATURE: 170°F (76.6°C)
 Use Bunn-O-Matic tubing, part number 32759.10XX
 (See Illustrated Parts Catalog for complete part number)
 for hot water connection.

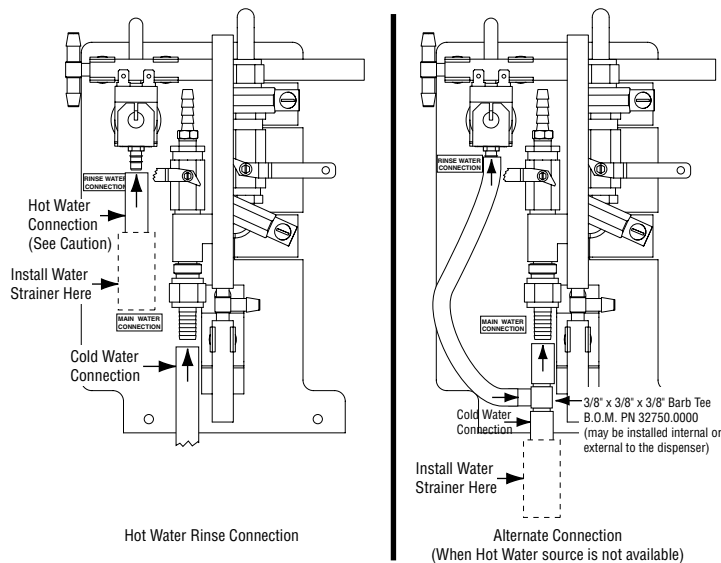

NOTES:

- Use Bunn-O-Matic tubing, part number 32759.10XX for all connections. (See Illustrated Parts Catalog for complete part number)
- Clamp all hose connections with Bunn-O-Matic part number 21275.0003 (hose clamp)

34054.0000A 10/01 ©2001 BUNN-O-MATIC CORPORATION

34054.0000

(Early Models prior to the Water Inlet Valve)

CHARGE

Type R134A, Amount 10 oz (283 gm)
 Design Pressures:
 High **335** psi (23 bar) (2.31 MPa)
 Low **88** psi (6 bar) (0.61 MPa)

33461.0000

WARNING

- DO NOT OVERLOAD CIRCUIT.
- ALWAYS ELECTRICALLY GROUND THE CHASSIS OR ADAPTOR PLUG.
- DO NOT DEFORM PLUG OR CORD.
- FOLLOW NATIONAL AND LOCAL ELECTRICAL CODES.
- KEEP COMBUSTIBLES AWAY.

FAILURE TO COMPLY RISKS EQUIPMENT DAMAGE, FIRE OR SHOCK HAZARD.

READ THE ENTIRE OPERATING MANUAL BEFORE USING THIS PRODUCT

00986.0002E 5/98 ©1994 Bunn-O-Matic Corporation

00986.0002

WARNING

Moving Parts.	Risk Of Electrical Shock.
Do not operate unit with this panel removed.	Disconnect power before servicing unit.

27442.0000

This equipment must be installed to comply with the International Plumbing Code of the International Code Council and the Food Code Manual of the Food and Drug Administration (FDA). For models installed outside the U.S.A., comply with the applicable Plumbing /Sanitation Code.

00656.0000

INITIAL SET-UP

CAUTION: The dispenser is very heavy! Use care when lifting or moving it. Use at least two people to lift or move the dispenser. Place the dispenser on a sturdy counter or shelf able to support at least 230 lbs. (104.3 kg). The JDF-4 is designed for indoor use only.

Set the dispenser on the counter where it will be used. The JDF-4 requires a minimum of 4 inches (102 mm) of air clearance at the rear and 8 inches (203 mm) of air clearance above the dispenser. Minimal clearance is required between the dispenser sides and the wall or another appliance. For optimum performance, **do not** let warm air from surrounding machines blow on the JDF-4. Leave some space so the dispenser can be moved for cleaning.

ELECTRICAL REQUIREMENTS

CAUTION: The dispenser must be disconnected from the power source until specified in *Electrical Hook-Up*. The 120V rated dispenser has an attached cord set and requires a 2-wire, grounded, individual branch circuit rated 120 volts ac, 15 amp, single phase, 60Hz. The mating connector must be a NEMA5-15R. (Refer to the dataplate for exact electrical requirements.)

The 230V rated dispenser has an attached cord set and requires an attachment plug cap rated at least 230 volts ac, 15 amp. The attachment plug cap must meet with applicable national/local electrical codes.

ELECTRICAL HOOK-UP

CAUTION: Improper electrical installation will damage electronic components.

1. An electrician must provide electrical service as specified.
2. Using a voltmeter, check the voltage and color coding of each conductor at the electrical source.
3. Connect the dispenser to the power source.
4. If plumbing is to be hooked up later, be sure the dispenser is disconnected from the power source. If plumbing has been hooked up, the dispenser is ready for *Initial Fill*.

CE REQUIREMENTS

- This appliance must be installed in locations where it can be overseen by trained personnel.
- For proper operation, this appliance must be installed where the temperature is between 0°C to 35°C.
- Appliance shall not be tilted more than 10° for safe operation.
- An electrician must provide electrical service as specified in conformance with all local and national codes
- This appliance must not be cleaned by water jet.
- This appliance is not intended for use by persons (including children) with reduced physical, sensory or mental capabilities, or lack of experience and knowledge, unless they have been given instructions concerning use of this appliance by a person responsible for its safety.
- If the power cord is ever damaged, it must be replaced by the manufacturer or authorized service personnel with a special cord available from the manufacturer or its authorized service personnel in order to avoid a hazard.

PLUMBING REQUIREMENTS

This dispenser must be connected to a **COLD WATER** system with operating pressure between 20 and 100 psi (138 and 690 kPa). This water source must be capable of producing a minimum flow rate of 3 fluid ounces (88.7 milliliters) per second. A shut off valve should be installed in the line before the dispenser. Install a regulator in the line when pressure is greater than 100 psi (690 kPa) to reduce it to 50 psi (345 kPa). Also if the install location experiences pressure fluctuations greater than 20 psi (138kPa). The main water inlet is a 3/8" (9.52 mm) male flare.

Additionally, the dispenser's rinse connection may be connected to a **HOT WATER** system.

Caution: MAXIMUM RINSE WATER TEMPERATURE: 170 degrees F (76.6 degrees C)

Use BUNN-O-MATIC tubing, part number 34325.10__ (see Illustrated Parts Catalog for complete part number) for hot water connection.

The rinse water operating pressure must be between 20 and 100 psi (138 and 690 kPa). A shut off valve should be installed in the line before the dispenser. Install a regulator in the line when pressure is greater than 100 psi (690 kPa) to reduce it to 50 psi (345 kPa). The rinse water inlet is a 3/8" (9.52 mm) barb connection.

NOTE- At least 18 inches (457 mm) of an FDA approved flexible beverage tubing, such as reinforced braided polyethylene, before the dispenser will facilitate movement to clean the countertop. It can be purchased direct from BUNN-O-MATIC (part number 34325.10__ [see Illustrated Parts Catalog for complete part number.]) BUNN-O-MATIC does not recommend the use of saddle valves to install the dispenser. The size and shape of the hole(s) made in the supply line(s) by saddle valves may restrict water flow.

NOTE- On early models dispensers without water inlet valve, a water strainer (Bunn-O-Matic part number 23720.1000) should be installed in line, prior to the flexible water line. This strainer is supplied loose with the dispenser.

NOTE - Water pipe connections and fixtures directly connected to a potable water supply shall be sized, installed and maintained in accordance with federal, state and local codes.

This equipment must be installed to comply with the International Plumbing Code of the International Code Council and the Food Code Manual of the Food and Drug Administration (FDA). For models installed outside the U.S.A., you must comply with the applicable Plumbing/Sanitation Code for your area.

PLUMBING HOOKUP

CAUTION: The dispenser must be disconnected from the power source throughout the plumbing hookup.

For early models without the water inlet valve, plumbing connections are located behind the dispenser's splash panel. Hoses are connected to the water valve(s) and travel under the water bath tank and out the rear of the dispenser. A .38" female flare connector is attached to the hose and connects to the supplied water strainer. The water strainer is shipped loose, taped to the bottom panel.

For late models with the water inlet valve, a hose assembly from the water bath shut-off valve travels over the top of the water bath tank to the product coil and the water inlet valve. A .75" hose to .38" male flare fitting attaches to the water inlet valve.

To access the water valves in the front of the dispenser, remove the drip tray assembly; remove the two screws securing the splash panel to the dispenser and remove the splash panel.

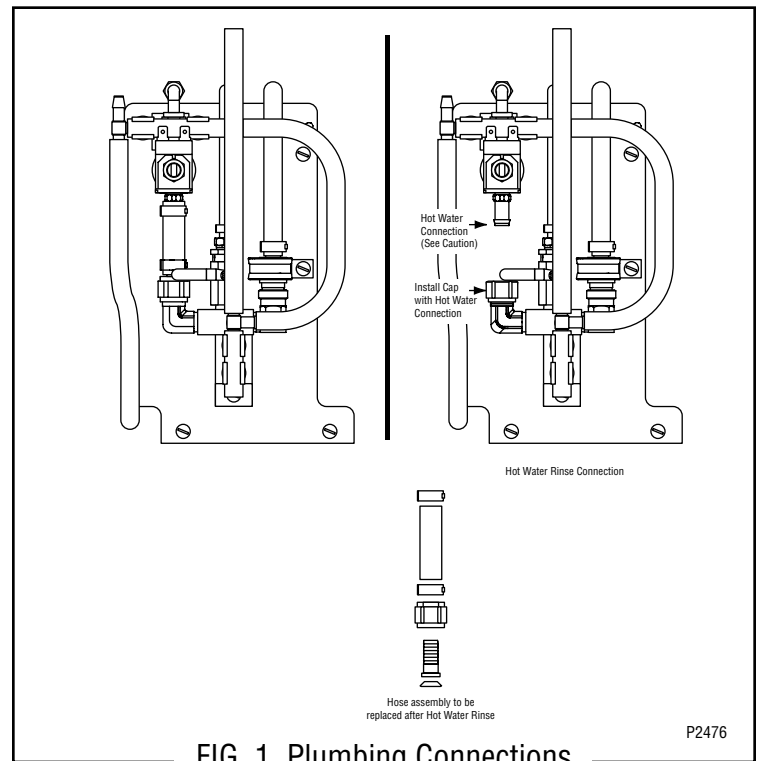

OPERATING CONTROLS

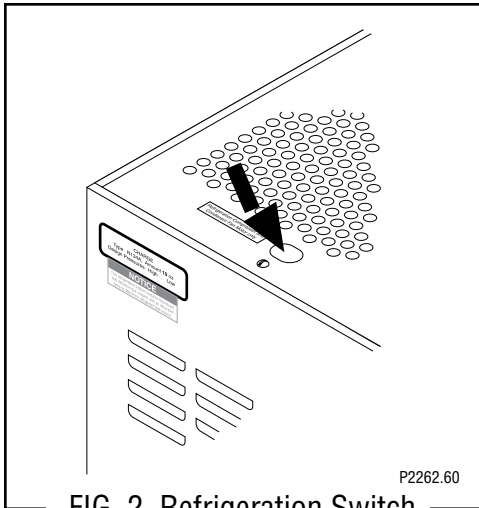

FIG 2 Refrigeration Switch

Refrigeration Switch

The refrigeration switch is located on the top of the dispenser near the left rear corner. This switch controls power to the compressor and the condenser fan motor.

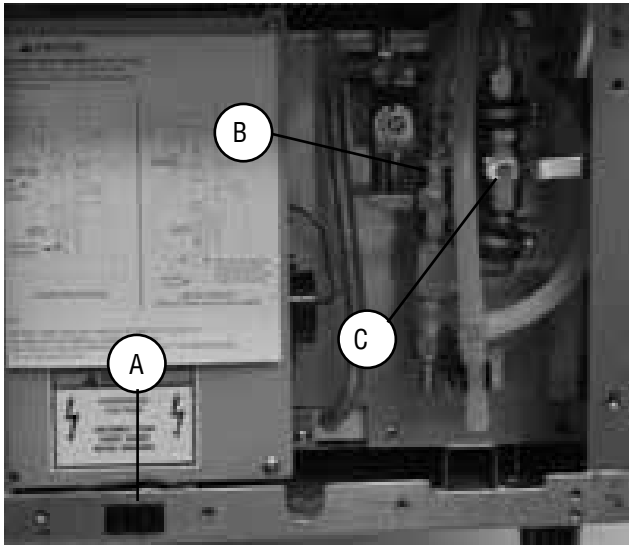

FIG 3 Sanitize Switch & Water Valves

Sanitize Switch

The sanitize switch is located behind the drip tray in the lower left corner of the chassis. The drip tray can be removed to provide easy access to the switch. The sanitize switch is used to enter and exit the sanitize mode and to initiate the sanitize automatic cycle. Refer to Weekly Sanitizing in the Cleaning section for detailed instructions on the use of this switch.

Water Bath Valve

This valve is manually operated and located above the drip tray, behind the splash panel. The drip tray and splash panel must be removed to gain access to the valve. On early models, the valve on the right (large) is the main water valve. Refer to the Initial Fill section for detailed instructions on the use of these valves.

- A. Sanitize Switch
- B. Water Bath Valve
- C. Main Water Valve (Early Models)

OPERATING CONTROLS (cont.)

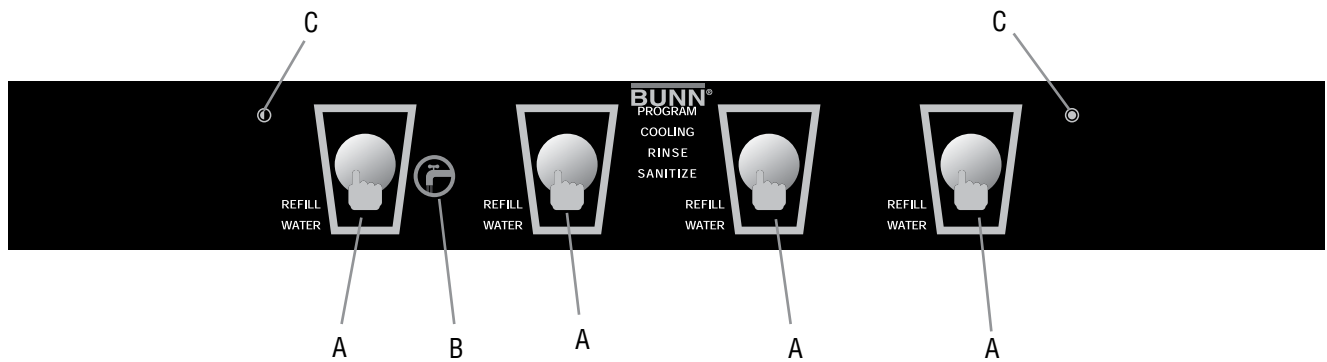

FIG 4 Press and Hold Models

A. Product Dispense Switch

Pressing and holding switch will initiate product flow from the respective nozzle; releasing the switch will stop the flow.

B. Chilled Water Dispense Switch

Pressing and holding switch will initiate chilled water flow from the nozzle; releasing the switch will stop the flow.

C. Hidden Switch

These switches are used to access, change and exit the dispenser program mode.

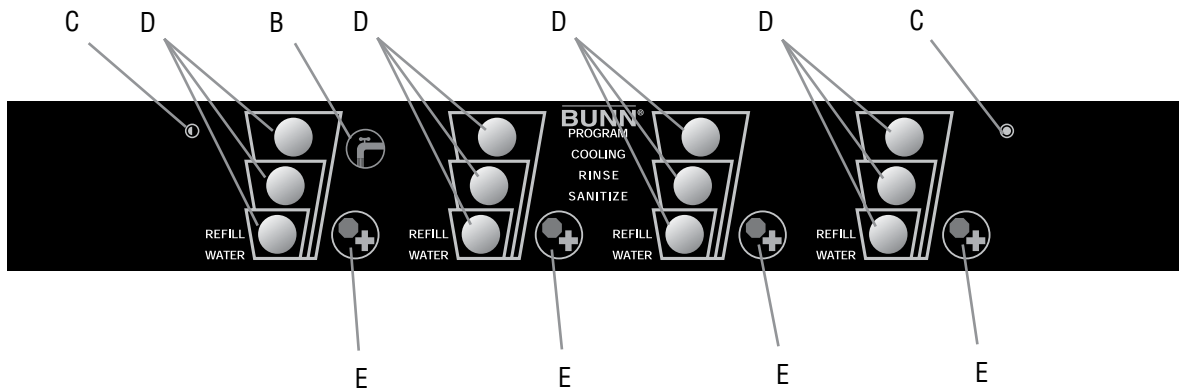

FIG 5 Portion Control Models

B. Chilled Water Dispense Switch

Pressing and holding switch will initiate chilled water flow from the nozzle; releasing the switch will stop the flow.

C. Hidden Switch

These switches are used to access, change and exit the dispenser program mode.

D. Product Dispense Switch

Momentarily pressing and releasing one of the switches will initiate a timed dispense. Each station has three different timed dispenses which are preset at the factory. Refer to DISPENSER USE section for preset volumes and adjustment procedures.

E. Plus/Stop Switch

This switch can be used to “top-off” a beverage. Pressing and holding switch will initiate product flow from the respective nozzle; releasing the switch will stop the flow. Momentarily pressing this switch during a timed dispense will stop the flow.

INITIAL FILL

CAUTION: The dispenser must be disconnected from the power source throughout the initial fill except when specified in the instructions.

1. Remove drip tray assembly and splash panel from the dispenser. Set the drip tray back into place.
2. Ensure that the Main Water Valve (Early models) and the Water Bath Valve Fig 3, are turned off (handles positioned at 3 o'clock and 9 o'clock, respectively,) and that the Refrigeration Switch Fig 2, is in the OFF (rear) position.
3. Turn on the water supply.
4. Connect the dispenser to the power source.
5. For late models with the water inlet valve, simultaneously press the two hidden switches (C, Figs 4 & 5) to enter the program mode. This activates the water inlet valve at the rear of the dispenser and allows water to flow to the water bath valve at the front of the dispenser.
6. While observing the water bath sight gauge (the clear tube located just to the left of the plumbing connections,) begin filling the water bath by rotating the handle of the Water Bath Valve counterclockwise to the 6 o'clock position. The dispenser will beep for three seconds when the bath is approaching full. Reduce the flow rate at this time.
7. When the water level in the sight gauge comes within 1 inch (25.4 mm) of the clear plastic tee, reduce the water flow by rotating the handle of the Water Bath Valve clockwise to the 8 o'clock position.
8. When the water in the water bath sight gauge begins to trickle down into the drip tray, turn the Water Bath Valve off by rotating the handle clockwise to the 9 o'clock position.
9. After approximately 3 minutes (this allows the recirculating pump and cabinet cooling components an opportunity to fill with water,) top off the water bath tank by rotating the handle of the Water Bath Valve counterclockwise to the 8 o'clock position.
10. Again, when the water in the water bath sight gauge begins to trickle down into the drip tray, turn the Water Bath Valve off by rotating the handle clockwise to the 9 o'clock position.
11. Place the Refrigeration Switch ON (forward.)
12. It will take approximately 4 hours at 70 degrees F (21 degrees C) ambient to create the ice bank required for full dispenser performance. During this time, some further trickling from the water bath is expected due to expansion caused by ice bank formation. While the refrigeration system is creating the ice bank, the dispenser may be readied for use as described in *Loading, Priming and Adjustment*.
13. The dispenser will safely store concentrate once the "COOLING" indicator completely extinguishes (not lit steadily or flashing.)
14. For early models, after the refrigeration compressor switches off, turn Main Water Valve on by rotating the handle counterclockwise to the 12 o'clock position.
15. Replace the splash panel and drip tray assembly.

LOADING

Frozen Concentrates

1. Thaw the frozen concentrate in a refrigerated 35-40 degrees F (1.6-4.4 degrees C) environment for 36 to 48 hours before use.
2. Thoroughly mix the thawed concentrate by vigorously shaking the product container.
3. Open the dispenser door.
4. Prior to placing the product container in the dispenser, make sure that the o-ring on the container adapter is lubricated. This will ease removal of the container when it becomes necessary.
5. Place the product container in the desired position and press it firmly into the bottle adapter opening.
6. Open the vent hole in the product container.

Note: Concentrate in the container must be completely thawed and be within the temperature range of 35-40 degrees F (1.6-4.4 degrees C.) Product outside of this temperature range, especially below, will produce an "out of brix" drink.

INITIAL FILL (cont)

Ambient Concentrates (Optional)

1. Install an Ambient Concentrate Conversion Kit (BUNN-O-MATIC part number 33699.0000) per the instructions provided in the kit.
2. Attach the concentrate product hose to the appropriate concentrate line located behind the dispenser's splash panel.
3. Attach the other end of the product hose to the product container through an appropriate fitting.

PRIMING

1. Open the dispenser door
2. Load concentrate per instructions in section titled *Loading*.
3. Close the dispenser door.

Note: The dispenser will not operate with the door open.

4. Place a large container under the appropriate dispense nozzle.
5. Dispensers with Press and Hold Feature:

Press and hold the "Product Dispense Switch" Fig 4, until concentrate dispenses from the dispense nozzle.

Dispensers with Portion Control Feature:

Press and hold the "+/STOP Switch" Fig 5, until concentrate dispenses from the dispense nozzle.

Note: This may take several seconds, depending on the installation and programmed pump speed.

DISPENSER USE

Press and Hold Models (Refer to Fig 4)

1. Place a cup on the drip tray beneath the desired dispensing nozzle.
2. Press and hold the "Product Dispense" or "Chilled Water" switch until the beverage/water reaches the desired level, then release.

Portion Control Models (Refer to Fig 5)

1. Place a cup on the drip tray beneath the desired dispensing nozzle.
2. Momentarily press the appropriate cup size switch to dispense the beverage. The dispenser is factory preset to produce the approximate beverage sizes as follows:

Small (4.0 seconds): approximately 7 fl.oz. (207 ml)

Medium (6.9 seconds): approximately 12 fl.oz. (355 ml)

Large (9.1 seconds): approximately 16 fl.oz. (473 ml)

The dispense times can be individually programmed by following the procedures described in *ADJUSTMENT - Cup Size Programming*.

To stop a timed dispense, momentarily press the "+/Stop Switch".

3. To "top-off" a beverage, press and hold the "+/Stop Switch" until the beverage reaches the desired level, then release.
4. To dispense chilled water, press and hold the "Chilled Water Switch" until the water reaches the desired level, then release.

CLEANING & PREVENTIVE MAINTENANCE

General Cleaning and Sanitizing Procedures

Note: The Bunn Juice Dispenser incorporates a rinse reminder feature which lights the rinse led on the front panel when it is time to rinse. See dip switch function list to activate this feature.

Daily: Rinse Procedure

Tools required: 32 oz. (946 ml) minimum empty container

1. Open the refrigerated compartment's door to access the "DISPENSE/RINSE" Knobs Fig 6.
2. Select the stations that will be rinsed and then rotate the appropriate Knob(s) to the rinse position. It is recommended that ALL dispense heads be rinsed daily. **Note:** If a station is in service lockout, leave its knob in the Dispense position.
3. Close the refrigerated compartment's door.
4. Place the empty container under the dispense nozzle to catch the rinse water.

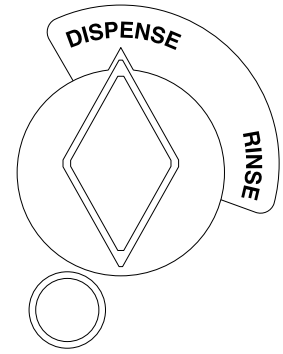

FIG 6 Dispense/Rinse Switch

5. Press and release the appropriate "Product Dispense Switch" Fig 4. This will initiate a timed rinse cycle. Portion control users can press any of the 3 "Product Dispense Switches" Fig 5, to initiate a timed rinse cycle.
6. Repeat for each dispense head.
7. Open the refrigerated compartment's door and return each knob to the dispense position.
8. Actuate the station's Dispense Switch until concentrate appears from the dispense nozzle.

Daily: Parts Washing

1. Remove and wash the dispense nozzle(s), mixing element(s), drip tray, drip tray cover, and cup stop in a mild detergent solution. Rinse thoroughly.
2. Wipe splash panel, areas around dispense nozzle(s), and drip trough in refrigerated compartment with a clean, damp cloth.

Weekly: Sanitizing

Tools required: Nozzle tubing (BUNN-O-MATIC part number 03289.1002) recommended when sanitizing multiple dispense heads simultaneously, 1 empty 5 gallon (18.9 L) bucket, 2 packets of Kay 5 sanitizer, and clean, empty concentrate containers.

Note: The Bunn juice dispenser features a semiautomatic sanitizing program. When sanitizing multiple heads simultaneously, attach Bunn sanitize tubing (BUNN-O-MATIC part number 03289.1002) on the end of each dispense nozzle and run tubing to the 5 gallon (18.9 L) bucket.

1. Remove any juice concentrate from the dispenser and store in a separate refrigerated compartment.
2. Perform the rinse procedures as previously described. (Note: If the dispenser is plumbed for hot water rinse, proceed to step 9.)
3. Fill clean empty concentrate container(s) with approximately 128 oz. (3.8 L) of the hot tap water (approximately 140°F (60°C). Load the containers of hot water into the dispenser (just like concentrate). Verify the rinse knobs are in the "DISPENSE" position.
4. Remove the drip tray and verify that the nozzle tubes are positioned within the empty bucket.
5. Press and hold the "Sanitize Switch" Fig 4, located on the front left portion of the base, for 5 seconds. The "SANITIZE" indicator on the front panel will begin to flash and the beeper will sound twice indicating that you have entered the sanitize mode.

CLEANING (cont)

6. Select the dispense stations by pressing the “Dispense Switch” for that station. Use the “+/Stop Switch” for portion control dispensers. The “REFILL” indicator will light and the beeper will sound for the dispense head selected.
7. Once the dispense heads have been selected, press and hold the “Sanitize Switch” for 5 seconds again to initiate the automatic cycle. (When the cycle is initiated the “SANITIZE” indicator lights steadily and the “REFILL” indicator for each station being sanitized will flash.)

Note: The sanitize routine takes 8 minutes. During the sanitize routine the following steps will occur in sequence:

- A) The pumps at the selected dispense heads will run for 1 minute, or until the bottles filled with hot water empty, whichever occurs first.
- B) The dispenser will sit idle for 5 minutes.
- C) The pumps at the selected dispense heads will run for 2 minutes or until the bottles filled with hot water empty, whichever occurs first.
- D) The beeper will sound once every 3 seconds to indicate completion of the sanitize routine.

Note: To terminate a sanitize program mid-cycle, momentarily press and release the “Sanitize Switch” and proceed to step 17. The sanitize program should be restarted from step 1 to ensure proper sanitization.

8. Once the cycle is completed, disconnect the sanitizing hose(s) from the nozzle(s) and empty the bucket.
9. Remove each dispense nozzle and mixing element and run under hot tap water to remove excess pulp.
10. Prepare 2.5 gal. (9.46 L) of sanitizing solution by dissolving 1 packet of Kay 5 sanitizer into 2.5 gal. (9.46 L) of 120°F (48.9°C) water to ensure 100 ppm of available chlorine.
11. Place nozzle(s) and mixing element(s) in a separate 1 quart container of sanitizing solution and mix thoroughly. Allow the part to soak for 2 minutes.
12. Clean the dispense nozzle receptacle(s) (dispense valves) with the sanitizing solution and a soft bristle brush.
13. Clean the concentrate bottle’s inlet adapter(s) using the sanitizing solution and a soft bristle brush.
14. Replace the mixing element(s) and nozzle(s), reattach the sanitizing hose(s) to the nozzle(s), and insert the hoses into the catch bucket.
15. Fill approximately 128 ounces (3.8 L) of clean sanitizing solution into clean, empty concentrate container(s). Do not use the sanitizing solution used in step 11. Load the containers into the dispenser.
16. Repeat steps 5 through 8.

Note: The sanitize routine takes 8 minutes. During the sanitize routine the following steps will occur in sequence:

- A) The pumps at the selected dispense heads will run for 1 minute, or until the bottles filled with sanitizing solution empty, whichever occurs first.
- B) The dispenser will sit idle for 5 minutes.
- C) The pumps at the selected dispense heads will run for 2 minutes or until the bottles filled with sanitizing solution empty, whichever occurs first.
- D) The beeper will sound once every 3 seconds to indicate completion of the sanitize routine.

17. Replace the sanitizing solution with concentrate and reattach the drip tray.
18. Activate a rinse cycle at each station as described in DAILY RINSE PROCEDURE.
19. At each station, actuate the Dispense Switch until juice appears. Then pour one 12 ounce (354.9 ml) glass of juice and discard.
20. Wipe internal and external surfaces with a clean, damp cloth.

CLEANING (cont)

Monthly: Clean Condenser Air Filter

1. Remove the condenser air filter located on the rear of the dispenser.
2. Using a water spray, clean the air filter.

Annually: Replace Pump Tubing

39689.0000	Tube Kit JDF-2S & JDF-4S
39687.0000	Tube Assembly

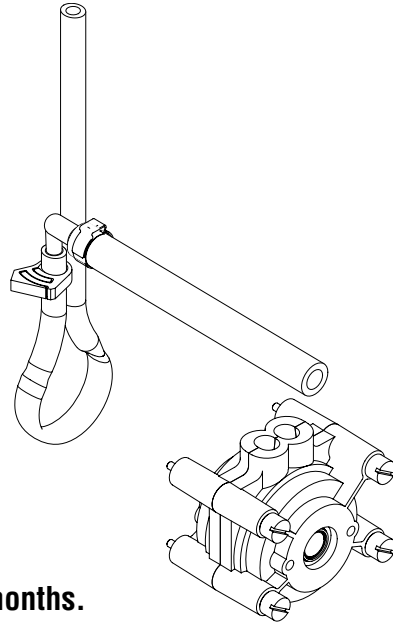

NOTE: High volume applications may require tubing changes every 6 months.

1. Open dispenser door.
2. Remove all product containers and place them in a refrigerated (35-40 degrees F [1.6-4.4 degrees C]) environment. Disconnect all connections to ambient products from the bottle adapter.
3. Close the dispenser door and dispense product at each station until the product runs clear.
4. Remove the drip tray assembly and splash panel from the dispenser.
5. Replace the drip tray assembly.
6. Turn the Main Water valve to the 3 o'clock position.
7. Open the dispenser door and remove the product shelf.
8. Remove the DISPENSE/RINSE knobs Fig 6, all dispense nozzles, the 2 screws securing the cover to the dispense platform, and the cover.
9. Disconnect the dispense platform's water lines from the supply lines inside the refrigerated cabinet and disconnect the wiring connections from the cabinet receptacles.
10. Remove the 2 thumb-screws securing the dispense platform to the cabinet .
11. Slowly pull the dispense platform forward to allow access to the rear wiring harness connector.
12. Disconnect the rear wiring harness connector from its receptacle.
13. Pull the dispense platform completely out of the cabinet and place it on a flat work surface.
14. Close the dispenser door.
15. Remove the 4 screws securing the pump body to the pump mount.
16. Gently pull the pump tube from around the pump's rotor.
17. Release the clamp securing the old pump tubing to the plastic elbow.
18. Pull the plastic elbow from the old pump tubing, and discard the old pump tubing.
19. Insert the plastic elbow into the new pump tubing and secure it with the clamp.
20. Gently wrap the new pump tubing around the pump's rotor, making sure that the elbows and clamps end up on the top-side of the pump body and don't protrude through the exit slots.
21. Repeat steps 15 through 20 for the remaining pumps.
22. Replace the dispense platform into the refrigerated cabinet, making sure to reconnect all electrical and water connections.
23. Turn the Main Water Valve to the 12 o'clock position. Check for leaks.
24. Replace the thumb-screws, cover, DISPENSE/RINSE knobs and dispense nozzles.
25. Turn all DISPENSE/RINSE knobs to the RINSE positions. Close the door and run a rinse at each station. Check for leaks.
26. Replace product shelf and product containers. Reconnect any connections to ambient product containers.
27. Prime the pumps as described in "PRIMING" in the Initial Fill Section.

ADJUSTMENT & OPTIONAL SETTINGS

Total Dispense Ratio Set Up Procedure

1. Adjust water flow as described in **Water Flow Testing and Adjustment**. Record water output setting for later reference on each dispense head.
2. Enter program mode by simultaneously pressing both hidden switches.
3. Press and hold the dispense button, you will hear 5 beeps then two short beeps, continue holding until you hear three short beeps. At this time the dispenser will run product and water for 3 seconds.
4. Record the total ounces dispensed.
5. Refer to the Brix/Ratio chart below to confirm proper total dispensed amount for ratio desired and water output previously recorded.
6. To increase or decrease the product output, refer to **Pump Speed Programming** section. *

* Always dispense 12 ounces of finished product after making a pump speed adjustment before taking an additional sample for the brix/ratio check.

3 second water dispense (oz)	Ratio Target													
	2:1	3:1	4:1	5:1	6:1	7:1	8:1	9:1	10:1	11:1	12:1	13:1	14:1	15:1
1.5	2.25	2.00	1.88	1.80	1.75	1.71	1.69	1.67	1.65	1.64	1.63	1.62	1.61	1.60
1.75	2.63	2.33	2.19	2.10	2.04	2.00	1.97	1.94	1.93	1.91	1.89	1.88	1.88	1.87
2.0	3.00	2.67	2.50	2.40	2.33	2.29	2.25	2.22	2.20	2.18	2.17	2.15	2.14	2.13
2.25	3.38	3.00	2.81	2.70	2.63	2.57	2.53	2.50	2.48	2.45	2.44	2.42	2.41	2.40
2.5	3.75	3.33	3.13	3.00	2.92	2.86	2.81	2.78	2.75	2.73	2.71	2.69	2.68	2.67
2.75	4.13	3.67	3.44	3.30	3.21	3.14	3.09	3.06	3.03	3.00	2.98	2.96	2.95	2.93
3.0	4.50	4.00	3.75	3.60	3.50	3.43	3.38	3.33	3.30	3.27	3.25	3.23	3.21	3.20
3.25	4.88	4.33	4.06	3.90	3.79	3.71	3.66	3.61	3.58	3.55	3.52	3.50	3.48	3.47
3.5	5.25	4.67	4.38	4.20	4.08	4.00	3.94	3.89	3.85	3.82	3.79	3.77	3.75	3.73
3.75	5.63	5.00	4.69	4.50	4.38	4.29	4.22	4.17	4.13	4.09	4.06	4.04	4.02	4.00
4.0	6.00	5.33	5.00	4.80	4.67	4.57	4.50	4.44	4.40	4.36	4.33	4.31	4.29	4.27
4.25	6.38	5.67	5.31	5.10	4.96	4.86	4.78	4.72	4.68	4.64	4.60	4.58	4.55	4.53
4.5	6.75	6.00	5.63	5.40	5.25	5.14	5.06	5.00	4.95	4.91	4.88	4.85	4.82	4.80
4.75	7.13	6.33	5.94	5.70	5.54	5.43	5.34	5.28	5.23	5.18	5.15	5.12	5.09	5.07
5.0	7.5	6.67	6.25	6.00	5.83	5.71	5.63	5.56	5.50	5.45	5.42	5.38	5.36	5.33
	Dispensed product (oz)													

Temperature Compensated Refractometer Method

1. Adjust the water flow as described in *Water Flow Testing and Adjustment*.
2. Place an empty container under the appropriate dispense nozzle.
3. Dispensers with Press and Hold Feature:
Press and hold the “Product Dispense Switch” Fig 4, until water and concentrate begin flowing freely from the dispense nozzle.
- Dispensers with Portion Control Feature:
Press and hold the “+/Stop Switch” Fig 5, until water and concentrate begin flowing freely from the dispense nozzle.
4. Discard the product caught previously and place the empty container back under the dispense nozzle.
5. Dispensers with Press and Hold Feature:
Press and hold the “Product Dispense Switch” until the cup is filled.
- Dispensers with Portion Control Feature:
Press and hold the “+/Stop Switch” until the cup is filled.
6. Stir the contents of the cup, and use the refractometer (according to the manufacturer’s instructions) to check the brix %.
7. Adjust the pump speed (down to decrease the brix %; up to increase the brix %) to achieve the correct brix % as described in *Pump Speed Programming*.

ADJUSTMENT & OPTIONAL SETTINGS (cont)

Water Flow Testing and Adjustment

1. Enter the “Pump Speed Programming” mode by simultaneously pressing both “Hidden Switches” Fig 4 or Fig 5. Note that the beeper sounds twice and that the “PROGRAM” indicator begins flashing.
2. Place a graduated measuring cup or the large chamber of the empty brining cup (BUNN-O-MATIC part number 33095.0000) under the appropriate dispense nozzle.
3. Press and hold the desired “Product Dispense Switch” Fig 4 (“+/Stop Switch” Fig 5, for portion control dispensers) for 5 seconds. Note that the beeper sounds once per second (6 times, total) during this period.
4. At the end of the 5 second period, the selected position will dispense water (no concentrate) for only 3 seconds.
5. Measure the water dispensed.
6. Adjust the water flow rate Fig 7, (clockwise to increase flow rate; counterclockwise to decrease flow rate) to the corresponding product mix ratio as follows:

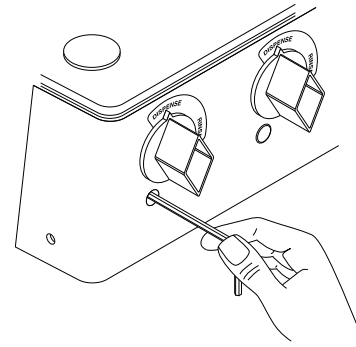

FIG 7 Adjusting Water Flow Using 1/4" allen wrench

Mix Ratio (water + concentrate)	Adjust water flow rate to:	Product	Brix %
2+1	*3.75 fl. oz (111 ml) per 3-second test	Prune Juice	16.0%
		Other	*
4+1	*4.0 fl. oz (118 ml) per 3-second test	Orange Juice	11.8%
		Pineapple Juice	12.8%
		Cranberry Fruit Cocktail	14.0%
5+1	*4.0 fl. oz (118 ml) per 3-second test	Grapefruit Juice	10.6%
		Lemonade	
		Apple Juice	12.0%
		Fruit Punch	
		Grape Juice	13.0%
3+1 through 7+1		Other	*
Above 7+1	*4.0 fl. oz (118 ml) per 3-second test	Other	*
High Viscosity Juice	2.25 - 3.0 fl. oz (66.5 - 89 ml) per 3-second test	As Required	-

*Maximum flow rate may be less depending on the water pressure supply at each location.

Note: Information for specific products listed in this table is to be used for reference only. Consult the product label for exact mix ratio and/or brix %. See product label for target brix %.

7. Repeat steps 3 through 6 as necessary until the correct water flow rate is achieved.
8. Repeat steps 3 through 7 for the remaining dispense positions.
9. Exit the “Pump Speed Programming” mode by simultaneously pressing both “Hidden Switches”. Note that the beeper sounds twice and the “PROGRAM” indicator extinguishes.

Pump Speed Programming

1. Enter the “Pump Speed Programming” mode by simultaneously pressing both “Hidden Switches”. Note that the beeper sounds twice and that the “PROGRAM” indicator begins flashing.
2. To increase the pump speed, press and hold the right-hand “Hidden Switch” (filled circle) and then momentarily press the “Product Dispense Switch” Fig 4 (“+/STOP Switch” Fig 5, for portion control dispensers). Each time the “Product Dispense Switch (“+/STOP Switch”) is pressed, the motor speed is increased by one step (5 revolutions per minute [RPM].) Note that each step is confirmed by a single flash of the appropriate “REFILL” indicator and a single tone from the beeper.

ADJUSTMENT & OPTIONAL SETTINGS (cont)

3. To decrease the pump speed, press and hold the left-hand “Hidden Switch” (half-filled circle) and then momentarily press the “Product Dispense Switch (“+/STOP Switch” for portion control dispensers). Each time the “Product Dispense” (“+/STOP”) Switch is pressed, the motor speed is decreased by one step (5 RPM.) Note that each step is confirmed by a single flash of the appropriate “REFILL” indicator and a single tone from the beeper.
4. Repeat as necessary at the remaining dispense stations.
5. Exit the “Pump Speed Programming” mode by simultaneously pressing both “Hidden Switches”. Note that the beeper sounds twice and that the “PROGRAM” indicator extinguishes.

NOTE: Dispense at least 12 oz. of finished product before dispensing a sample to check brix. This will allow the pump time to adjust to the new speed.

Chilled Water Flow Testing and Adjustment

1. Enter the “Pump Speed Programming” mode by simultaneously pressing both “Hidden Switches”. Note that the beeper sounds twice and that the “PROGRAM” indicator begins flashing.
2. Place a graduated measuring cup or the large chamber of the empty brining cup (BUNN-O-MATIC part number 33095.0000) under the appropriate dispense nozzle.
3. Press and hold the “Chilled Water Switch” Fig 4 or Fig 5, for 5 seconds. Note that the beeper sounds once per second (6 times, total) during this period.
4. At the end of the 5 second period, the chilled water will dispense for 3 seconds.
5. Measure the water dispensed. (Approx. 4.5 fl. oz. [133 ml])
6. If adjustment is required, remove all concentrate bottles from dispenser and disconnect any optional ambient concentrate hoses. Remove product shelf from dispenser.
7. Adjust the Chilled Water Flow Valve Fig 8, clockwise to decrease flow rate; counterclockwise to increase flow rate.
8. Repeat steps 3 through 6 as necessary until the desired water flow rate is achieved.
9. Exit the “Pump Speed Programming” mode by simultaneously pressing both “Hidden Switches”. Note that the beeper sounds twice and that the “PROGRAM” indicator extinguishes.



FIG 8 Chilled Water Flow Valve P3487

Cup Size Programming (Portion Control Dispensers Only)

1. Enter the “Cup Size Programming” mode by simultaneously pressing the “LARGE” and “SMALL” cup size switches at any dispense station. Note that the beeper sounds twice and that the “PROGRAM” indicator lights steadily.
2. Press and hold the desired cup size switch at the appropriate dispense position until the correct cup volume is achieved. Top up as necessary by momentarily pressing the same cup size switch. Note that if DIP switch #2 on the control board is set to the “on” position, concentrate must be present in order to dispense or program cup sizes.
3. Repeat as necessary for the remaining cup sizes and dispense stations.
4. Exit the “Cup Size Programming” mode by pressing any of the “+/STOP Switches”. Note that the beeper sounds twice and that the “PROGRAM” indicator extinguishes.

Dispenser Lockout

Dispense and Rinse functions of the dispenser can be electronically locked-out to prevent unauthorized use of the dispenser, while keeping the refrigeration system running. Two different lock-out modes are available as follows:

Mode #1 locks out all dispense functions.

Mode #2 locks out all dispense functions except the chilled water dispense.

ADJUSTMENT & OPTIONAL SETTINGS (cont)

1. Enter the "Pump Speed Programming" mode by simultaneously pressing both "Hidden Switches". Note that the beeper sounds twice and that the "PROGRAM" indicator begins flashing.
2. Enter a "Lockout" password as follows:
 - a) Press and hold the left hand "Hidden Switch" (half filled circle) for mode #1, the right hand "Hidden Switch" (filled circle) for mode #2.
 - b) In a 5 second period, press and release the "Chilled Water Switch" the number of times that you want the password set to (maximum of 10.) For example: If you want the password set to 3, press and release the "Chilled Water Switch" 3 times in the 5 second period.
 - c) Release the "Hidden Switch".
 - d) At the end of the 5 second period, the password will be confirmed by the "REFILL" indicators flashing the password, and the appropriate lock-out mode will be selected.
3. Exit the "Pump Speed Programming" mode by simultaneously pressing both "Hidden Switches". Note that the beeper sounds twice and that the "PROGRAM" indicator extinguishes.
4. To lockout the dispenser, proceed as follows:
 - a) Press and hold either "Hidden Switch".

Note: The lock-out mode selected during password programming is automatically selected, regardless of the hidden switch used to lock-out the dispenser.

- b) In a 5 second period, press and release the "Chilled Water Switch" the "password" number of times. For example: If the password is set to 3, press and release the "Chilled Water Switch" 3 times in the 5 second period.
 - c) Release the "Hidden Switch".
 - d) At the end of the 5 second period, the dispenser will extinguish the merchandising lamp, and all dispense functions will be disabled.
5. To enable the dispenser, proceed as follows:
 - a) Press and hold either "Hidden Switch".
 - b) In a 5 second period, press and release the "Chilled Water Switch" the "password" number of times. For example: If the password is set to 3, press and release the "Chilled Water Switch" 3 times in the 5 second period.
 - c) Release the "Hidden Switch".
 - d) At the end of the 5 second period, the dispenser will light the merchandising lamp, and dispense functions will be enabled.

6. If the password is forgotten, it can be reset to "0" (dispenser lockout disabled) as follows:

Note: The following procedure also clears the programming and service lockout password.

- a) Disconnect the dispenser from its power source.
- b) Place the "Refrigeration Switch" Fig 2, in the OFF (reward) position.
- c) While pressing and holding the "Chilled Water Switch", connect the dispenser to its power source.
- d) Continue to hold the "Chilled Water Switch" until the dispenser beeps three times, then release.
- e) The passwords are now returned to "0" (no programming or service lockout password/dispenser lockout disabled.)
- f) After 3 minutes, place the "Refrigeration Switch" in the ON (forward) position.

Service Lockout

Should a dispense station become inoperative and require service, the station's dispense and rinse functions can be independently locked out, while keeping the remaining stations running.

1. To place a single dispense station in "Service Lockout," open the dispenser door, press and hold either "Hidden Switch" and the desired dispense station "Product Dispense" ("+/Stop") switch for 10 seconds.
2. At the end of the 10 second period, the beeper will sound a double tone and the dispense position will be disabled. Place the DISPENSE/RINSE Knob to "DISPENSE" and close the dispenser door.
3. To remove a dispense station from "Service Lockout," open the dispenser door, press and hold either "Hidden Switch" and the desired dispense station "Product Dispense" ("+/Stop") switch for 10 seconds.
4. At the end of the 10 second period, the beeper will sound a double tone and the dispense position will be enabled. Close the dispenser door.

ADJUSTMENT & OPTIONAL SETTINGS (cont)

Password Protection

The programming modes and service lockout function may be password protected to prevent accidental or unauthorized access to these features. The dispenser is shipped from the factory with a password of "0" (no password.)

1. Enter the "Pump Speed Programming" mode by simultaneously pressing both "Hidden switches". Note that the beeper sounds twice and that the "PROGRAM" indicator begins flashing.
2. Program a password as follows:
 - a) Press and hold either "Hidden Switch".
 - b) In a 5 second period, press and release the "Sanitize Switch" the number of times that you want the password set to (maximum of 10.) For example: If you want the password set to 3, press and release the "Sanitize Switch" 3 times in the 5 second period.

Note: To reset password to "0" (no password) press and hold the "Sanitize Switch", without either "Hidden Switch" pressed, for the 5 second period. When the password resets to "0", the beeper will sound and the "Water" indicators will illuminate for approximately 2 seconds.

- c) Release the "Hidden Switch".
 - d) At the end of the 5 second period, the password will be confirmed by the "WATER" indicators flashing the password.
 - e) From this point forward, the password must be entered before access is allowed to programming modes or the service lockout function.
3. To enter the password, proceed as follows:
 - a) Press and hold either "Hidden Switch".
 - b) In a 5 second period, press and release the "Sanitize Switch" the password number of times. For example: If the password is set to 3, press and release the "Sanitize Switch" 3 times in the 5 second period.
 - c) Release the "Hidden Switch".
 - d) Wait for the password to be confirmed by the flashing of the "Water" indicators.
 - e) Enter the desired program mode or select service lockout as normal within the next 5 seconds.

Note: If the program mode/service lockout is not selected within 5 seconds, it will be necessary to re-enter the password.

4. If the password is forgotten, it can be reset to "0" (no password) as follows:

Note: The following procedure also clears the dispenser lockout password.

- f) Disconnect the dispenser from its power source.
- g) Place the "Refrigeration Switch" in the OFF (rearward) position.
- h) While pressing and holding the "Chilled Water Switch", connect the dispenser to its power source.
- i) Continue to hold the "Chilled Water Switch" until the dispenser beeps three times, then release.
- j) The passwords are now returned to "0" (no programming or service lockout password/dispenser lockout disabled.)
- k) After 3 minutes, place the "Refrigeration Switch" in the ON (forward) position).

Dispense Fault List

“REFILL” indicator	Beeper	Fault
2 flashes	2 beeps	Dispense station locked out.
3 flashes	3 beeps	DISPENSE/RINSE sensing fault.
4 flashes	4 beeps	DISPENSE/RINSE knob mis-positioned.
5 flashes	5 beeps	Pump motor stalled/speed sensor inoperative.
All “REFILL” indicators flash 3 times	3 beeps	Dispenser locked out.

Cooling Fault List

Fault Code	“COOLING” indicator	DBC display (optional)	Fault	Fault Priority
8	8 flashes every 5 seconds	fault 8	Bath water level low. (Also lights all “WATER” indicators)	1
7	7 flashes every 5 seconds	fault 7	Bath temperature probe short circuit.	2
6	6 flashes every 5 seconds	fault 6	Bath temperature probe open circuit.	3
5	5 flashes every 5 seconds	fault 5	Cabinet temperature probe short circuit.	4
4	4 flashes every 5 seconds	fault 4	Cabinet temperature probe open circuit.	5
3	3 flashes every 5 seconds	fault 3	Cooling system failure (disables all dispense functions)	6
0	On steady temperatures	Bath/cabinet	Bath and cabinet temperatures excessive.	7
2	2 flashes every 5 seconds	Bath/cabinet temperatures	Bath temperature excessive.	8
1	1 flash every 5 seconds	Bath/cabinet temperatures	Cabinet temperature excessive. (Disables all dispense functions, flashes, all REFILL and WATER indicators, and sounds the beeper when temperature is excessive for more than 6 hours.)	9

Dip Switch Function List

Dip Switch	Controls	Off	On
1	“REFILL” indicator when “concentrate out” is detected.	Inactive	Active
2	Lockout dispense components when “concentrate out” is detected.	Inactive	Active (Note)
3	Number of positions that can dispense/rinse simultaneously.	3	2
4	Rinse timer	Off	On
5	Audio feedback during dispenses.	On	Off
6	Future use.	None	None

Note: When dip switch 2 is in the “on” position, the “REFILL” indicator is active, regardless of dip switch 1 position.

FUNCTION LIST

Function #	Description	Default Setting
0	Enter Password	0
1	Set Pump 1 RPM (Concentrate A)	180
2	Set Pump 2 RPM (Concentrate A)	180
3	Set Pump 3 RPM (Concentrate A)	180
4	Set Pump 4 RPM (Concentrate A)	180
101	Set Pump 1 RPM (Concentrate B)	180
102	Set Pump 2 RPM (Concentrate B)	180
103	Set Pump 3 RPM (Concentrate B)	180
104	Set Pump 4 RPM (Concentrate B)	180
7	Station 1 Large Cup Dispense Time (seconds)	9.1
8	Station 1 Medium Cup Dispense Time (seconds)	6.9
9	Station 1 Small Cup Dispense Time (seconds)	4.0
10	Station 2 Large Cup Dispense Time (seconds)	9.1
11	Station 2 Medium Cup Dispense Time (seconds)	6.9
12	Station 2 Small Cup Dispense Time (seconds)	4.0
13	Station 3 Large Cup Dispense Time (seconds)	9.1
14	Station 3 Medium Cup Dispense Time (seconds)	6.9
15	Station 3 Small Cup Dispense Time (seconds)	4.0
16	Station 4 Large Cup Dispense Time (seconds)	9.1
17	Station 4 Medium Cup Dispense Time (seconds)	6.9
18	Station 4 Small Cup Dispense Time (seconds)	4.0
27	Display Station 1 Refill ADC	*
28	Set Station 1 Refill Threshold	100
29	Display Station 2 Refill ADC	*
30	Set Station 2 Refill Threshold	100
31	Display Station 3 Refill ADC	*
32	Set Station 3 Refill Threshold	100
33	Display Station 4 Refill ADC	*
34	Set Station 4 Refill Threshold	100
50	Display Bath Level ADC	*
51	Set Bath Refill Threshold	140
52	Display Bath Temperature	*
53	Calibrate Bath Temperature	Must be below 50F to calibrate
54	Display Cabinet Temperature	*
55	Calibrate Cabinet Temperature	Must be below 50F to calibrate
75	Set Dispenser Lockout Password	0
76	Test Indicators	+ = on
77	Set Rinse Time (seconds)	4.0
78	Set Programming/Service Lock-out Password	0
99	Set DBC Function Access Password	0
100	Display Software Version	*

TROUBLESHOOTING

A troubleshooting guide is provided to suggest probable causes and remedies for the most likely problems encountered. If the problem remains after exhausting the troubleshooting steps, contact the Bunn-O-Matic Technical Service Department.

- Inspection, testing, and repair of electrical equipment should be performed only by qualified service personnel.
- All electronic components have 120-240 volt ac and low voltage dc potential on their terminals. Shorting of terminals or the application of external voltages may result in board failure.
- Intermittent operation of electronic circuit boards is unlikely. Board failure will normally be permanent. If an intermittent condition is encountered, the cause will likely be a switch contact or a loose connection at a terminal or crimp.
- Solenoid removal requires interrupting the water supply to the valve. Damage may result if solenoids are energized for more than ten minutes without a supply of water.
- The use of two wrenches is recommended whenever plumbing fittings are tightened or loosened. This will help to avoid twists and kinks in the tubing.
- Make certain that all plumbing connections are sealed and electrical connections tight and isolated.
- This brewer is heated at all times. Keep away from combustibles.

- WARNING –
- Exercise extreme caution when servicing electrical equipment.
 - Unplug the brewer when servicing, except when electrical tests are specified.
 - Follow recommended service procedures.
 - Replace all protective shields or safety notices.

PROBLEM

PROBABLE CAUSE

REMEDY

All water LED's flash.

1. Bath water level low.

Access bath fill valve and top off bath tank.

Cold Water Circulation

All dispense stations not working or all water & refill LED's flash and beep 3 times.

Note: Cooling failure or excessive bath and cabinet temperatures for more than 4 hours will result in touchpad lockout or no dispense.

Note: Reset fault/timer by unplugging unit.

1. Cabinet cooling fan.

Replace fan (24vdc).

Note: Fan receives power when door switch is closed.

2. Bath recirculation pump.

A) If not running, replace pump (120vac).

B) If no power, replace control board.

3. Restricted water flow to cabinet water coil and bath.

Clean or replace cabinet water strainer or recirculating manifold or check for kinked hose.

TROUBLESHOOTING (cont.)

PROBLEM

Refrigeration

All dispense stations not working or all water & refill LED's flash and beep 3 times.

Note: Cooling failure or excessive bath and cabinet temperatures for more than 4 hours will result in touchpad lockout or no dispense.

Dispenser Locked Out

All dispense stations not working or all water & refill LED's flash and beep 3 times.

Hint: Display light goes out during dispenser lockout feature, if the unit has lighted graphics.

Cooling system failure or DBC fault 3.

PROBABLE CAUSE

1. Compressor ON/OFF switch.
2. Dirty condenser filter or fins.
3. Condenser fan not running.
4. Compressor relay not activating.
5. Compressor not running.
6. Compressor running and not cooling.

1. Dispenser lockout password set.

1. Refrigeration or cold water recirculation system.

REMEDY

Check for "ON" position or no continuity - replace switch.

Clean or replace condenser filter.

Replace fan motor or check fan blades for obstructions.

Check compressor relay coil for 120vac.

NOTE: Always check power with coil attached. If no 120vac - replace board. If yes, 120vac - replace relay.

Note: Relay contacts normally open.

Check compressor thermal overload (N/C). If open check for dirty condenser filter or adequate ventilation and space around machine.

Check refrigeration system for leaks and proper charge.

See page 17 for instruction on how to reset or change password.

Check all previous items that pertain to refrigeration or cold water recirculation

TROUBLESHOOTING (cont.)

PROBLEM

Dispense station not working "refill" LED and beep code.

A) 3-Beep - Dispense/Rinse sensing fault.

B) 4-Beep - Dispense/Rinse knob mis-positioned.

PROBABLE CAUSE

1. Bottle adapter switch membrane

A) Dispense/Rinse switch membrane shorted out simultaneously.

B) Dispense/Rinse switch membrane open simultaneously.

2. Concentrate lockout (Dipswitch #2) feature activated - locks out station when refill light is ON.

3. Dispense touchpad.

Bottle adapter refill

Main water supply

Internal ON/OFF water valve

Frozen bath

REMEDY

Check for moisture at 3-pin connector and clean. Apply electrical insulating compound or replace defective switch membrane.

Check knob for mis-position or replace defective switch membrane.

Check for proper orientation of the Dispense/Rinse membrane switch.

Hint: Good bottle adapter switch membrane will sound the beeper when you rotate the knob between dispense and rinse to indicate closed position.

Refill product or turn OFF concentrate lockout feature (Dipswitch #2)

See Schematics and check corresponding dispense station button for continuity - replace touchpad.

Check wire terminals going to the probes for proper connection or refill probes need to be cleaned and rinsed.

NOTE: Door switch resets the "Refill" LEDs.

Check for ON position.

Check for ON position.

A) Compressor relay/contacts shorted - replace relay.

B) Recirculating pump - replace or check for kinked flex line.

Refill LED not extinguishing

All stations dispense concentrate only

TROUBLESHOOTING (cont.)

PROBLEM

Dispense station
concentrate only

PROBABLE CAUSE

Water solenoid

REMEDY

Replace solenoid (24vdc) or check wire connection between water valve and main control board.

Dispense station
water only

In rinse position
NOTE: Water will dispense for 4 seconds.

Rotate knob to dispense position.

Dispense starts then stops or "refill" flashes and beeps 5 times.

Main control board

Check for variable dc voltage when corresponding dispense switch is depressed. No dc power - replace control board.

Dispense motor not running

Check for variable dc voltage at motor terminals. Voltage present - replace motor.

RPM sensor

A) Verify magnet hub is secured with screw and star washer to motor shaft.

B) Verify RPM sensor operation.
RPM input 24vdc signal 0 - 5 vdc intervals.

TROUBLESHOOTING (cont.)

PROBLEM

Water leak filling drip tray or around dispense deck area

PROBABLE CAUSE

1. Initial fill/setup
2. Dispense deck
3. Water pressure greater than 100psi

REMEDY

Some expansion normal. May fill drip tray during initial ice block formation

Inspect or replace fittings clamps, o-rings, solenoids and quick disconnect fittings.

NOTE: Dispense deck area slopes to drain tube that leads to the drip tray.

Install water pressure regulator and reduce to 50 psi.

Water leaking beneath machine

1. Bath tank overflow.
2. Condensation from cabinet cooling coil.

A) Bath fill valve - check for closed position or replace leaking valve

B) Check all internal water connections.

Check for routing of condensation tube to drip tray.

Erratic spray during dispense

Dispense nozzle mixer missing or broken

Replace mixer.

Dispense nozzle dripping water

Dispense solenoid.

Replace dispense deck solenoid.

Can't access programming

Programming password feature activated.

See Password Protection to access programming or reset password to zero or change programming password.

Dispense touchpad

Check for continuity on half and full moon buttons. If no continuity when pressed, replace touchpad.

TROUBLESHOOTING (cont.)

PROBLEM

Unit is not working and no beep/light fault codes

PROBABLE CAUSE

1. Step-down transformer.
2. Main control board.

REMEDY

Check for 120/24 vac. If no 24vac reading, replace step-down transformer.

If 24 vac present and no red LED, replace control board..

Hint: Red LED on main control board is powered from the step-down transformer 24 vac and rectified to 24 vdc by the rectifier.

Difficulty brining and/or weak beverage

1. Product viscosity or too cold.
2. Low water pressure.
3. High water pressure.
4. Dispense valve adjustment setting.

Thorough thaw of product before use (35° - 40°)

Maintain 20 psi or higher and a minimum flow rate of 3 fl oz/sec.

Over 100 psi, install a pressure regulator and set to 50 psi.

A) Perform 3 second water dispense test. Factory setting is 1.0 oz/sec. Acceptable water flow rate is .-0.8 to 1.5 oz/sec depending on the mix ratio (4+1).

B) Adjust water to proper mix ratio. Once water is set, adjust motor speed (RPM) to achieve brix %.

5. Brix ratio.

Check for proper brix ratio per product using Total Dispense method and or refractometer method.

TROUBLESHOOTING (cont.)

PROBLEM

Difficulty brixing and/or weak beverage

PROBABLE CAUSE

- 1. Pump tubing.

- 2. Bottle adapter assembly leaking
NOTE: Leaking water into concentrate bottle during rinse of any station.

- 3. Use of portable water pump.

REMEDY

Inspect, clean, or replace tubing and pump rotor/rollers for ease of rotation.

Replace bottle adapter assembly.

A) Follow plumbing requirements for pressure and flow rate.

B) Source another portable pump or water supply that meets requirements.

Difficulty brixing bag-in-box

Vacuum leak

Inspect all lines and connections from bag-in-box connector to bottle adapter assembly. Vacuum leak test bottle adapter assembly. Repair vacuum leak or replace bottle adapter assembly.

COOLANT SCHEMATIC DIAGRAM

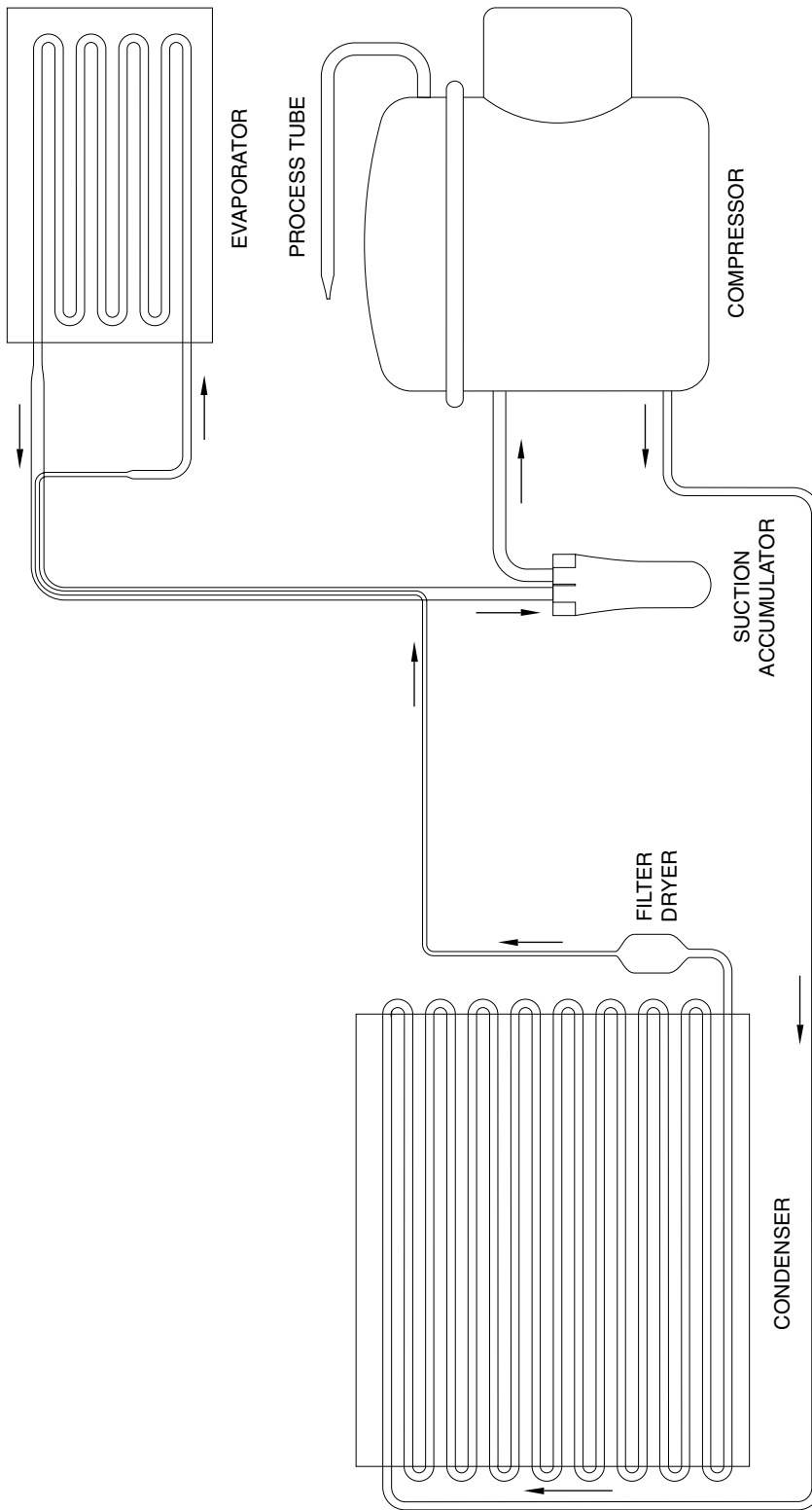

SCHEMATIC WIRING DIAGRAM

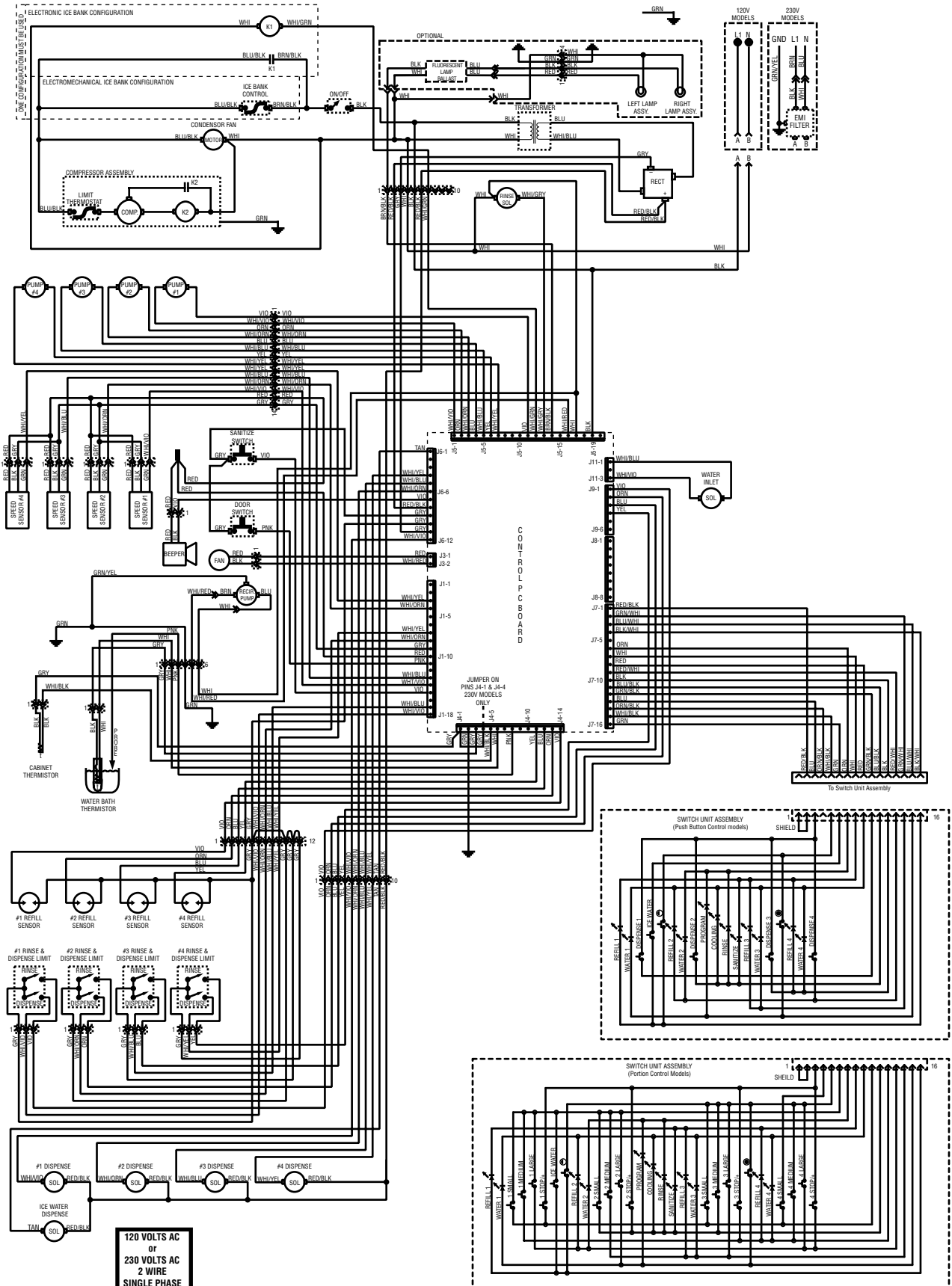

REFER TO THE FOLLOWING PAGES FOR DETAILED VIEWS OF INDIVIDUAL CIRCUITS

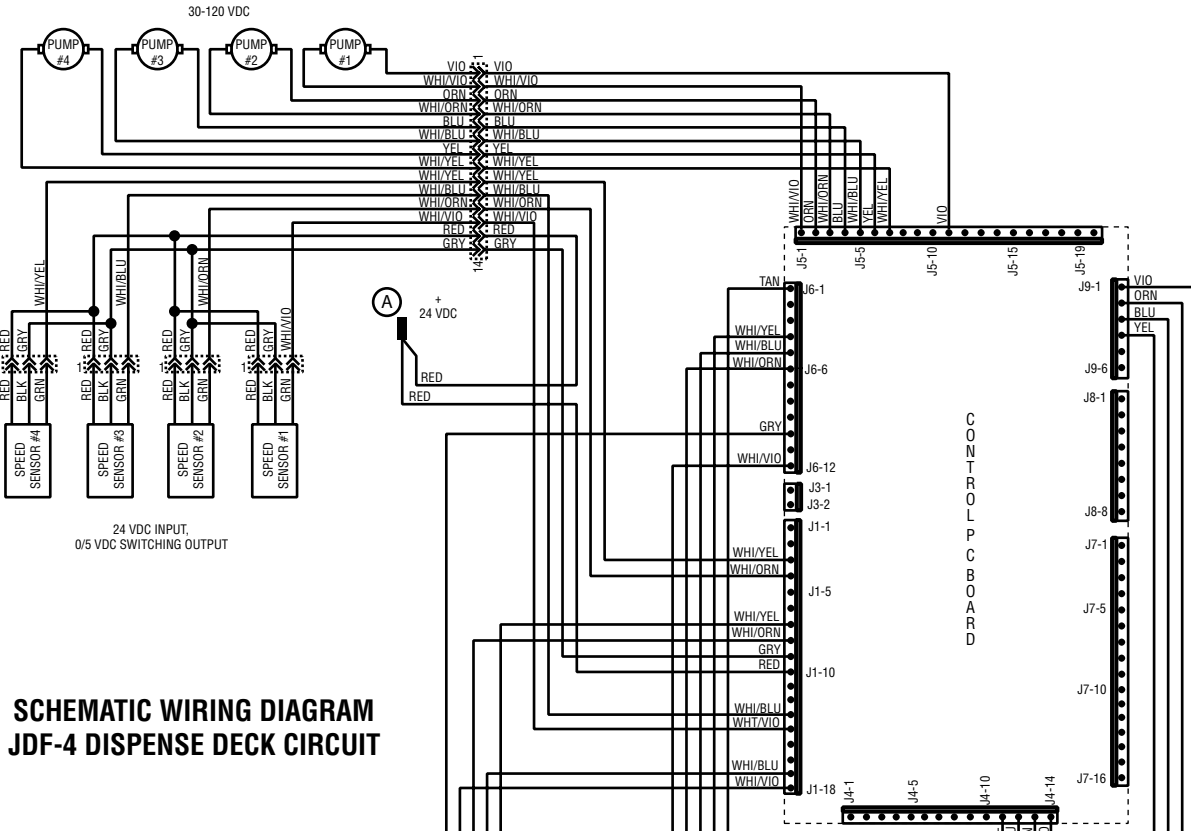

**SCHEMATIC WIRING DIAGRAM
JDF-4 DISPENSE DECK CIRCUIT**

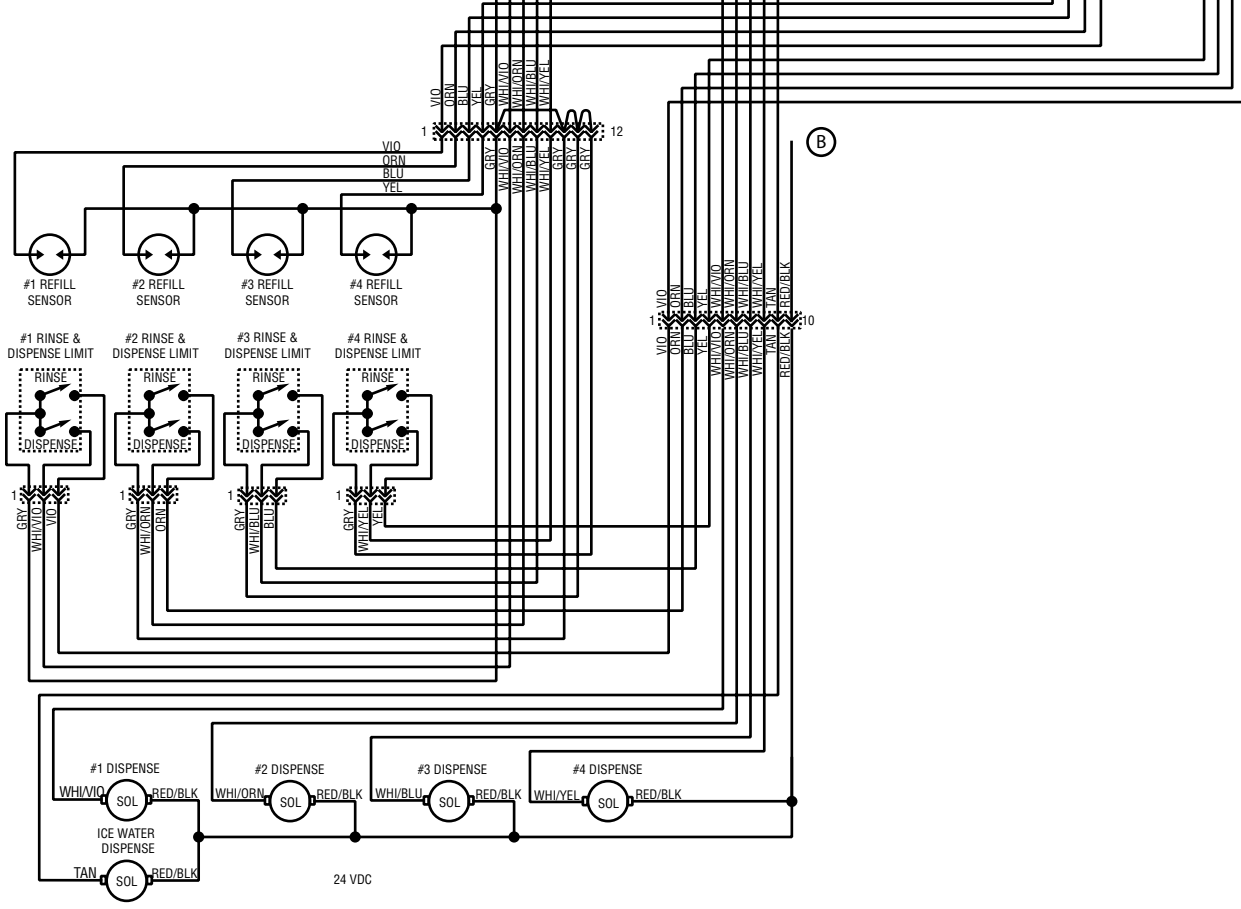

SCHEMATIC WIRING DIAGRAM JDF-4 CONTROL PANEL CIRCUIT

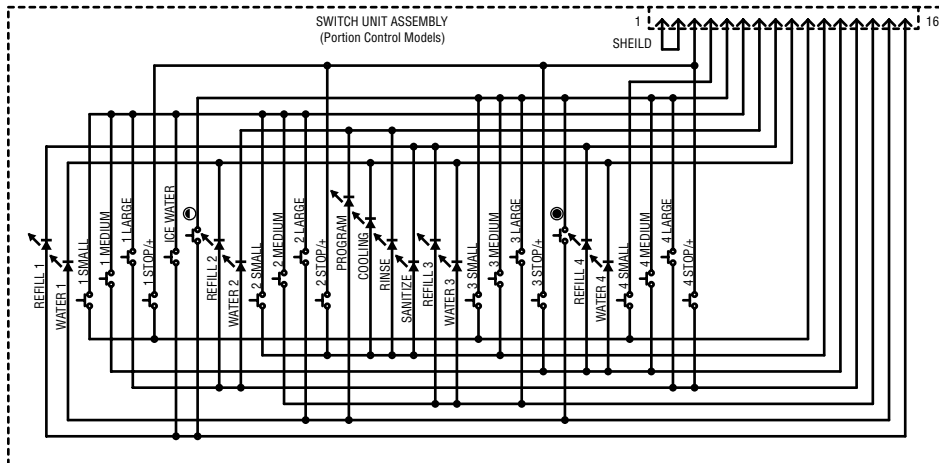
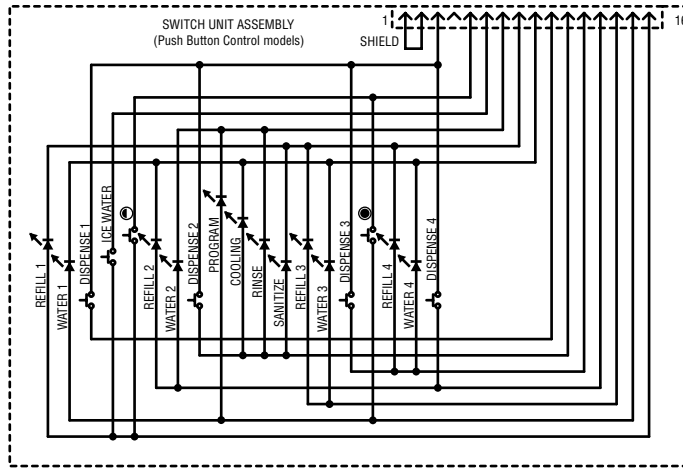
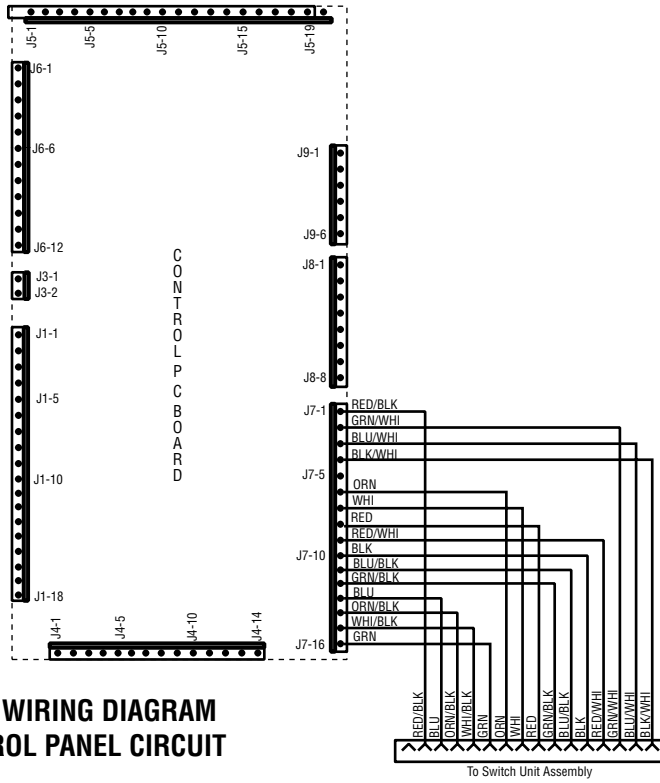

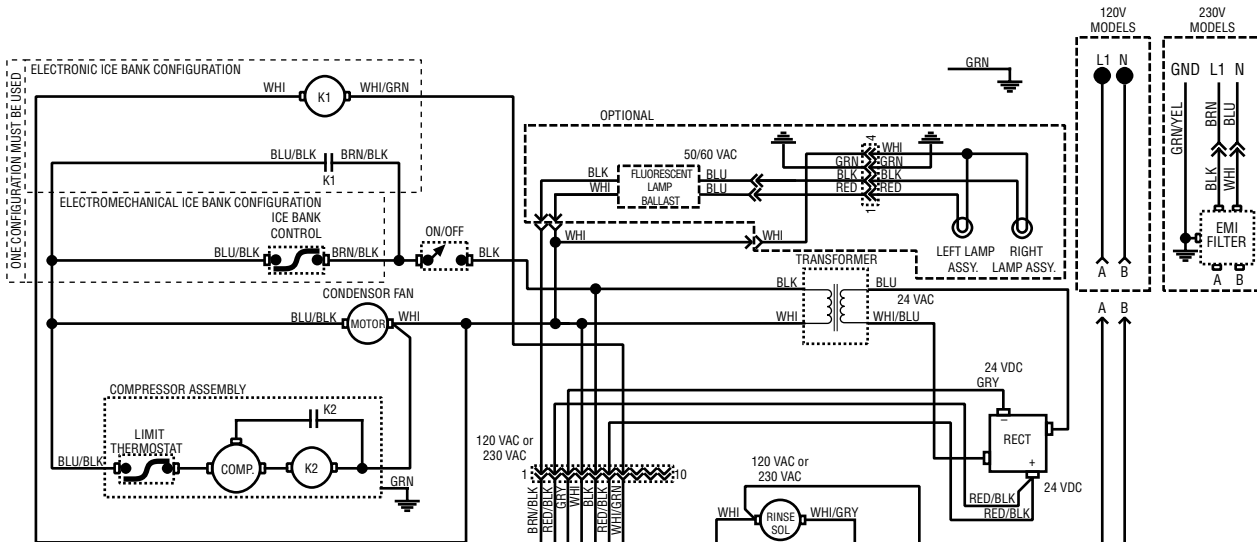

**SCHEMATIC WIRING DIAGRAM
JDF-4 REMAINING CIRCUITS**

