

**BH**

# LK510



# OWNER'S MANUAL

*Important: Read all instructions carefully before using this product. Retain this owner's manual for future reference.*

BH North America | 20155 Ellipse, Foothill Ranch, California 92610 | p.949.206.0330 | f.949.206.0013 | [www.BHFitnessUSA.com](http://www.BHFitnessUSA.com)



# TABLE OF CONTENTS

<b>Title</b>	<b>Page</b>
Introduction	03
Safety Information	04
Exercise Instruction	06
Training Guidelines	07
Workout and Stretching	11
Assembly Instructions	13
Console Overview	17
Console Operations	18
Exploded View Drawing	23
Parts List	24
Warranty	25

## CONGRATULATIONS

Congratulations on your purchase of BH Fitness equipment. We hope you appreciate the style, quality, and value that exercisers around the world have come to expect from BH Fitness.

If you have any questions, concerns or product issues, please call our Customer Service Team at 1-866-325-2339 or email us at [CustomerSupport@BHNorthAmerica.com](mailto:CustomerSupport@BHNorthAmerica.com).

Carefully read through the instructions contained in this manual. They provide you with important information about assembly, safety, fitness and use of the vibration machine. Please read ALL the safety information contained in the following pages.

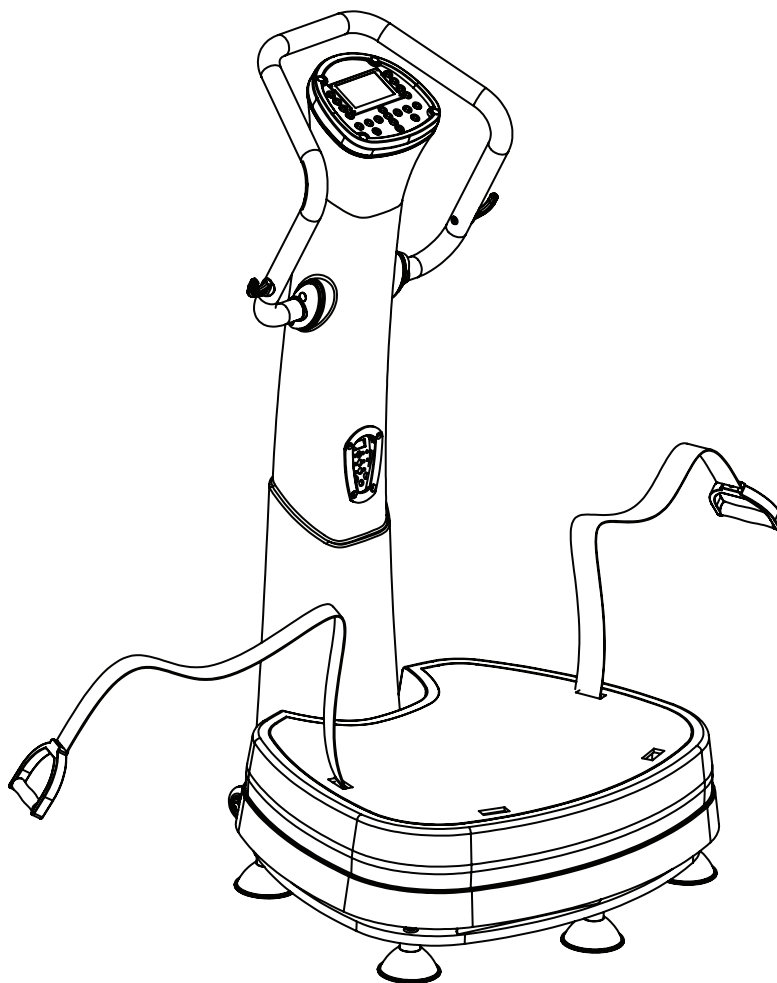

# SAFETY INFORMATION

## PRECAUTIONS

The vibration machine has been designed and constructed to provide maximum safety. Nevertheless, certain precautions should be taken when using exercise equipment. Read the whole manual before assembling and using the vibration machine. Please observe the following safety precautions:

1. Keep children and pets away from this equipment at all times. DO NOT leave them unsupervised in the room where the vibration machine is kept.
2. If you experience dizziness, nausea, chest pains or any other symptom while using this vibration machine STOP the exercise. SEEK IMMEDIATE MEDICAL ATTENTION!
3. Use the vibration machine on a level and solid surface.
4. Do not place hand or objects in or near any openings.
5. Wear clothing suitable for doing exercise. Always wear athletic shoes when using the vibration machine and tie the laces securely.
6. This vibration machine must only be used for the purposes described in this manual. DO NOT use accessories that are not recommended by BH Fitness.
7. Do not place sharp objects near the vibration machine.
8. Do not use the vibration machine if it is not working correctly.
9. Before using the vibration machine, thoroughly inspect the equipment for proper assembly.
10. Keep a clear perimeter of 3 feet (1 meter) around the vibration machine before operating the equipment.
11. Use only authorized and trained technicians if a repair is needed.
12. Please follow the advice for correct training, as detailed in the Training Guidelines.
13. Use only the tools provided to assemble this vibration machine.
14. This vibration machine was designed for a maximum user weight of 400 lbs (182 kgs).
15. The vibration machine can only be used by one person at a time.
16. To unplug the vibration machine, first put the switch to the off position and then unplug from the electrical outlet.
17. Do not use this vibration machine outside.
18. Do not use the vibration machine if the main electrical cord becomes damaged or worn. Keep the main electrical cord away from hot surfaces.

**Caution:** Consult your doctor before beginning to use the vibration machine or any exercise program. Read all of the instructions before using any exercise equipment.

KEEP THESE INSTRUCTIONS SAFE FOR FUTURE USE.

## SAFETY INFORMATION CONTINUED

This product must be grounded. If it malfunctions or breaks down, grounding will provide a path of least resistance for electric current to reduce the risk of electric shock. This cord must be plugged into an appropriate outlet that is properly installed and grounded in accordance with all local codes and ordinances.

Danger – Improper use can result in a risk of electric shock or fire. Check with a qualified electrician to ensure the product is properly grounded. Do not modify the cord provided with the product – if it does not fit the outlet, have a proper outlet installed by a qualified electrician. This product is designed for use with 110V-120V power. The unit is equipped with a NEMA 5-15 plug as illustrated in the figure below. No adapter should be used with the product.

**Figure A**

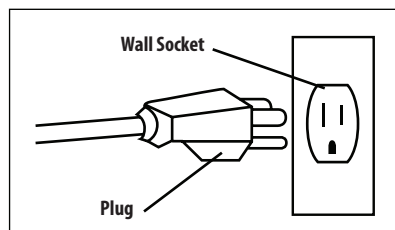

**Figure B**

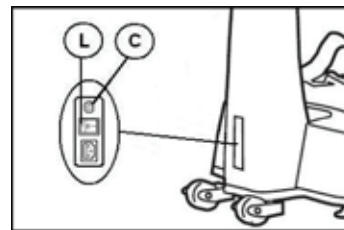

### SAFETY BREAKER

This vibration machine is equipped with a circuit breaker to protect both the electronic and electrical circuits. This safety device (fuse) will be automatically triggered if the vibration machine is subjected to abnormal electrical activities.

1. Set switch (L), located on the casing, to the “0” (OFF) position, then unplug the vibration machine.
2. Change the fuse (C) (7 Amp).
3. Plug the vibration machine into the electrical outlet. Next, set switch (L) to the “I” (ON) position and the unit will be ready for use again.



### DISPOSAL OF YOUR VIBRATION MACHINE

1. All electrical and electronic products should be disposed of at your local e-waste facility. If you have questions, your local waste disposal service can connect you with information about recycling e-waste. The correct disposal of your old equipment will help prevent potential negative consequences for the environment and your community.
2. For more detailed information about disposal of your old equipment, please contact your city office, waste disposal service, or the shop where you purchased the product.

## EXERCISE INSTRUCTION

Use of the vibration machine offers various benefits; it can improve fitness, muscle tone, flexibility and circulation. When used in conjunction with a calorie controlled diet, it can help you lose weight.

1. Consult your doctor before starting any exercise program. It is advisable to undergo a complete physical examination.
2. Exercise at recommended level. Do not over exert yourself.
3. If you feel any pain or discomfort, stop exercising immediately and consult your doctor.
4. Wear appropriate clothing and footwear for the exercise; do not wear leather soled shoes or high heels.
5. Step on to the equipment slowly and securely.
6. Select the program or workout option that is most closely aligned with your workout interests.

**Do not use this vibration machine if you are under any of the following conditions:**

- Pregnancy
- Acute thrombosis conditions
- Cardiovascular disease
- Hip or knee replacement
- Recent surgery
- Acute hernia, discopathy, spondylolysis
- Epilepsy
- Heavy migraines
- Wearing a pacemaker
- Wearing recently fitted i.u. coils, metal pins, bolts or plates
- Tumors
- Broken toe(s)

## TRAINING GUIDELINES

Exercise is one of the most important factors in the overall health of an individual. Listed among its benefits are:

- Increased capacity for physical work (strength endurance)
- Increased cardiovascular (heart and arteries/veins) and respiratory efficiency
- Decreased risk of coronary heart disease
- Changes in body metabolism, e.g. losing weight
- Delaying the physiological effects of age
- Reduction in stress, increase in self-confidence, etc.

There are several components of physical fitness and each is defined below.

### *STRENGTH*

The capacity of a muscle to exert a force against resistance. Strength contributes to power and speed.

### *MUSCULAR ENDURANCE*

The capacity to exert a force repeatedly over a period of time, e.g. it is the muscular endurance of your legs to carry you 10 km without stopping.

### *FLEXIBILITY*

The range of motion of your joints. Improving flexibility involves the stretching of muscles and tendons to maintain or increase suppleness, and it provides increased resistance to muscle injury or soreness.

### *CARDIO-RESPIRATORY ENDURANCE*

The most essential component of physical fitness. It is the efficient functioning of the heart and lungs.

### *AEROBIC FITNESS*

Is an exercise of relatively low intensity and long duration, which depends primarily on the aerobic energy system. Aerobic means "with oxygen", and refers to the use of oxygen in the body's metabolic or energy-generating process. Many types of exercise are aerobic, and by definition are performed at moderate levels of intensity for extended periods of time.

### *ANAEROBIC TRAINING*

Is an exercise intense enough to trigger anaerobic metabolism. This means "without oxygen" and is the output of energy when the oxygen supply is insufficient to meet the body's long term energy demands. (For example, a 100 meter sprint.)

### *OXYGEN UPTAKE*

The effort that you can exert over a prolonged period of time is limited by your ability to deliver oxygen to the working muscles. Regular vigorous exercise produces a training effect that can increase your aerobic capacity by as much as 20 to 30%. An increased VO<sub>2</sub> Max indicates an increased ability of the heart to pump blood, of the lungs to ventilate oxygen, and of the muscles to take up oxygen.

### *THE TRAINING THRESHOLD*

This is the minimum level of exercise which is required to produce significant improvements in any physical fitness parameter.

### *OVERLOAD*

This is where you exercise above your comfort level. The intensity, duration and frequency of exercise should be above the training threshold and should be gradually increased as the body adapts to the increasing demands. As your fitness level improves, the training threshold should rise. Working through your program and gradually increasing the overload factor is important.

### *PROGRESSION*

As you become more fit, a higher intensity of exercise is required to create an overload and therefore provide continued improvement.

### *SPECIFICS*

Different forms of exercise produce different results. The type of exercise that is carried out is specific to the muscle groups being used and to the energy source involved. There is little transfer of the effects of exercise, i.e. from strength training to cardiovascular fitness. That is why it is important to have an exercise program tailored to your specific needs.

### *REVERSIBILITY*

If you stop exercising or do not do your program often enough, you will lose the benefits you have gained. Regular workouts are the key to success.

### *WARM-UP*

Every exercise program should start with a warm-up where the body is prepared for the effort to come. It should be gentle and preferably use the muscles group to be involved later. Stretching should be included in both your warm-up and cool down, and should be performed after 3-5 minutes of low intensity aerobic activity or calisthenic type exercise.

### *WARM DOWN OR COOL DOWN*

This involves a gradual decrease in the intensity of the exercise session. Following exercise, a large supply of blood remains in the working muscles. If it is not returned promptly to the central circulation, pooling of blood may occur in the muscles.



### *HEART RATE*

As you exercise, your heart beat increases. This is often used as a measure of the required intensity of an exercise. You need to exercise hard enough to condition your circulatory system, and increase your pulse rate, but not enough to strain your heart.

Your initial level of fitness is important when developing an exercise program for you. When starting, you can get a good training effect with a heart rate of 110-120 beats per minute (BPM). If you are more fit, you will need a higher threshold of stimulation.

To begin with, you should exercise at a level that elevates your heart rate to about 65 to 70% of your maximum. If you find this is too easy, you may want to increase it, but it is better to lean on the conservative side.

As a rule of thumb, the maximum heart rate is 220 minus your age. As you increase in age, your heart, like other muscles, loses some of its efficiency. Some of its natural loss is won back as fitness improves. The following table is a guide to those who are “starting fitness.”

Age Target Heart Rate	25	30	35	40	45	50	55	60	65
10 Second Count	23	22	22	21	20	19	19	18	18
Beats per Minute	138	132	132	126	120	114	114	108	108

### *PULSE COUNT*

The pulse count (on your wrist or carotid artery in the neck, taken with two index fingers) is done for ten seconds, taken a few seconds after you stop exercising. This is for two reasons: (a) 10 seconds is long enough for accuracy, (b) the pulse count is to approximate your BPM rate at the time you are exercising. Since heart rate slows as you recover, a longer count isn't as accurate.

The target is not a magic number, but a general guide. If you're above average with your fitness, you may work comfortably a little above that suggested for your age group. The following table is a guide.

Age Target Heart Rate	25	30	35	40	45	50	55	60	65
10 Second Count	26	26	25	24	23	22	22	21	20
Beats per Minute	156	156	150	144	138	132	132	126	120

Don't push yourself too hard to reach the figures on this table. It can be very uncomfortable if you over exercise. Let it happen naturally as you work through your program. Remember, the target is a guide, not a rule, a little above or below is just fine.

Two final comments: (1) don't be concerned with day to day variations in your pulse rate, being under pressure or not enough sleep can affect it; (2) your pulse rate is a guide, don't become a slave to it.

### *MUSCLE SORENESS*

For the first week or so, muscle soreness may be the only indication you have that you are on an exercise program. This, of course, does depend on your overall fitness level. A confirmation that you are on the correct program is a very slight soreness in most major muscle groups. This is quite normal and will disappear in a matter of days.

If you experience major discomfort, you may be on a program that is too advanced, or you have increased your program too rapidly.

If you experience PAIN during or after exercise, your body is telling you something. Stop exercising and consult your doctor.

### *WHAT TO WEAR*

Wear clothing that will not restrict your movement in any way while exercising. Clothes should be light enough to allow the body to cool. Excessive clothing that causes you to perspire more than you normally would gives you no advantage. The extra weight you lose is body fluid and will be replaced with the next glass of water you drink. It is advisable to wear a pair athletic shoes.

### *BREATHING DURING EXERCISE*

Do not hold your breath while exercising. Breathe normally as much as possible. Remember, breathing involves the intake and distribution of oxygen, which feeds the working muscles.

### *REST PERIODS*

Once you start your exercise program, you should continue through to the end. Do not break off halfway through and then restart at the same place later on without going through the warm-up stage again. The rest period required between exercises may vary from person to person.

## SUGGESTED STRETCHES

### *Head Rolls*

Rotate your head to the right for one count while feeling the stretch up the left side of your neck. Next, rotate your head back for one count, stretching your chin to the ceiling. Rotate your head to the left for one count, and finally, drop your head to your chest for one count.

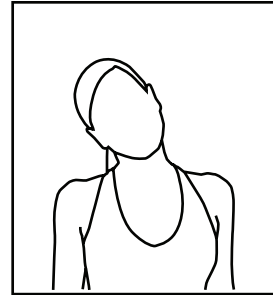

### *Shoulder Lifts*

Lift your left shoulder up toward your ear for one count. Then lift your right shoulder up for one count as you lower your left shoulder.

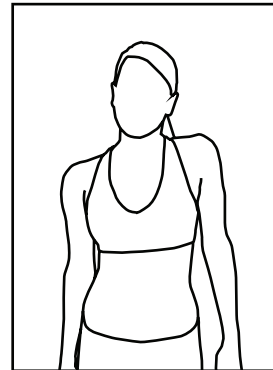

### *Side Stretches*

Open your arms to the side and continue lifting them until they are over your head. Reach your left arm as far upward as you can for one count. Feel the stretch up your left side. Repeat this action with your right arm.

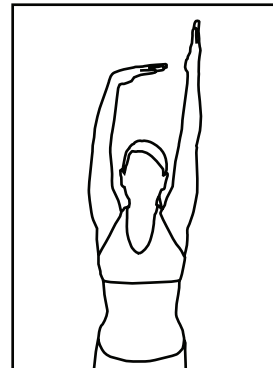

### *Quadriceps Stretch*

With one hand against a wall for balance, reach behind you and pull your left foot up. Bring your heel as close to your buttocks as possible. Hold for 15 counts and repeat with right foot up.

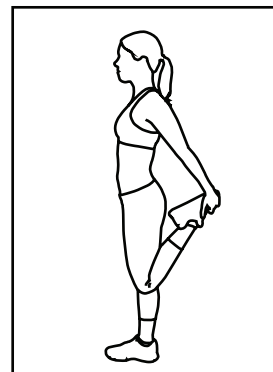

## SUGGESTED STRETCHES

### *Inner Thigh Stretch*

Sit with the soles of your feet together with your knees pointing outward. Pull your feet as close into your groin as possible. Gently push your knees towards the floor. Hold for 15 counts.

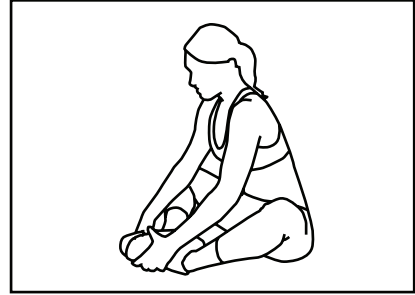

### *Toe Touches*

Slowly bend forward from your waist, letting your back and shoulders relax as you stretch toward your toes. Reach down as far as you can and hold for 15 counts.

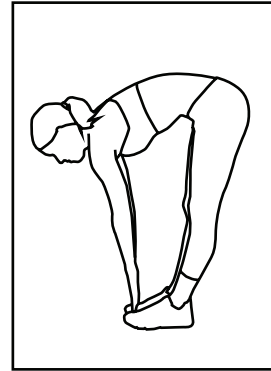

### *Hamstring Stretches*

Sit with your right leg extended. Rest the soles of your left foot against your right inner thigh. Stretch toward your toes as far as possible. Hold for 15 counts. Relax and then repeat with left leg extended.

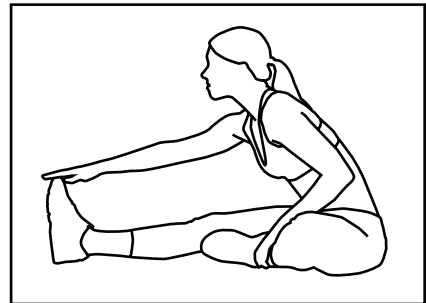

### *Calf/Achilles Stretches*

Lean against a wall with your right leg in front of the left and your arms forward. Keep your left leg straight and the right foot on the floor; then bend the right leg and lean forward by moving your hip toward the wall. Hold, then repeat on the other side for 15 counts.

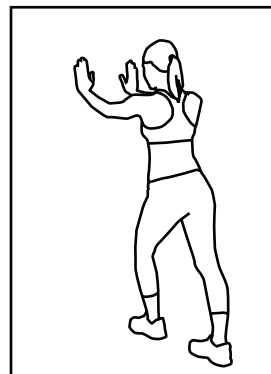

# ASSEMBLY INSTRUCTIONS

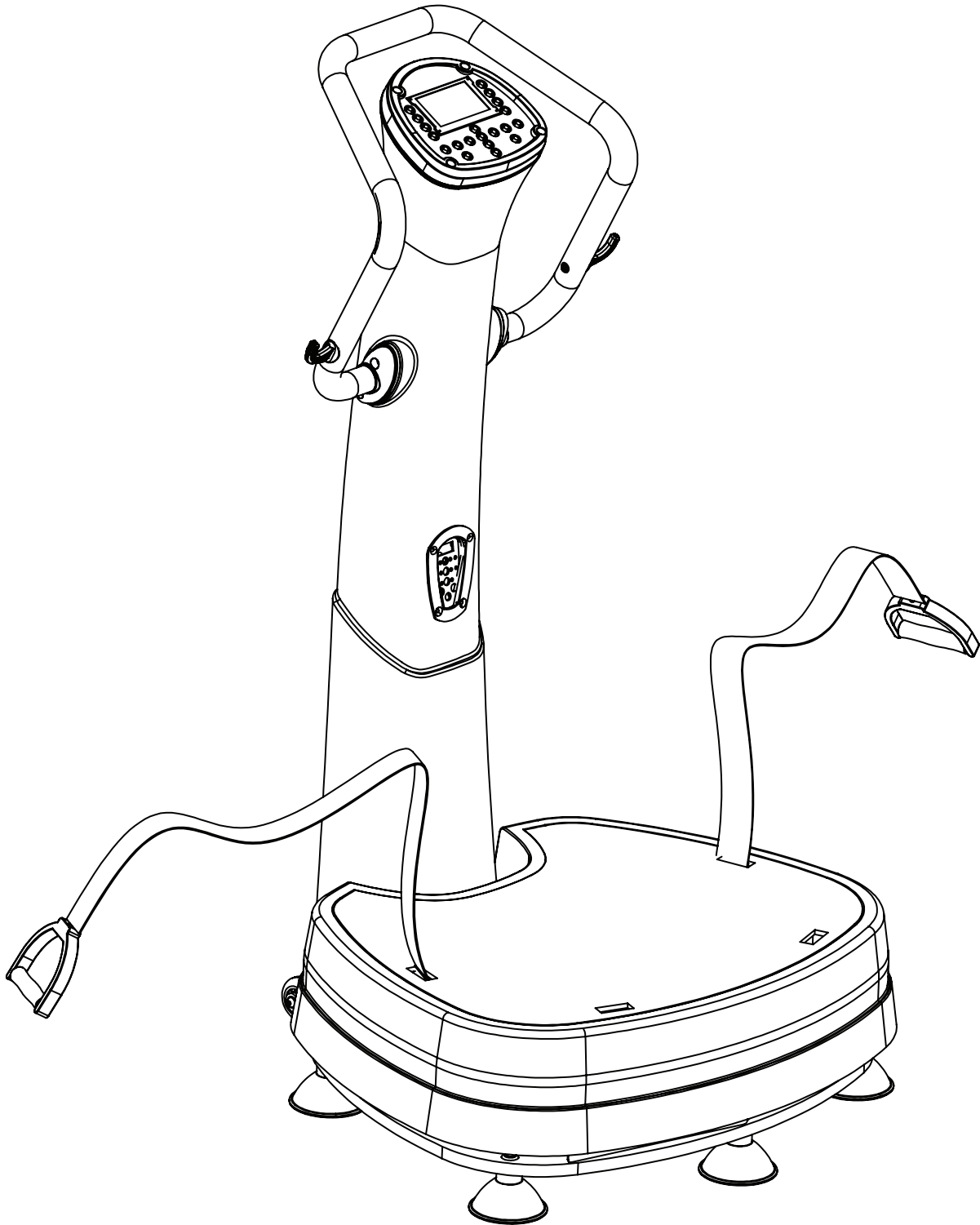

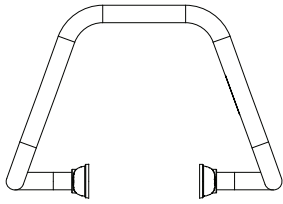

Handlebar

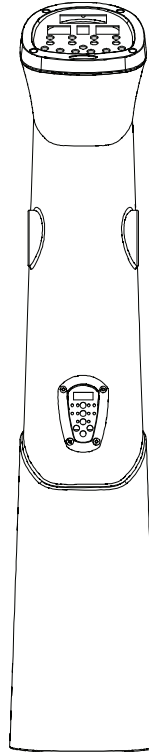

Upright Column

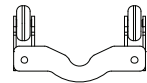

Roller Bracket



Power Cord

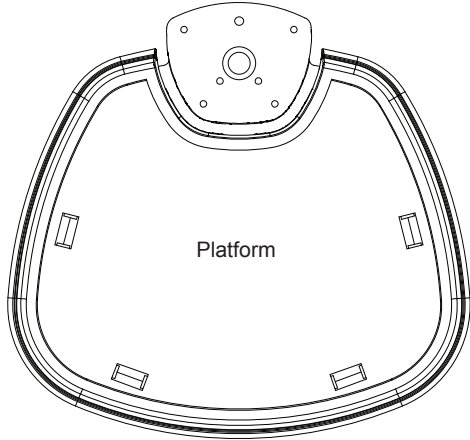

Platform

Hardware Packet

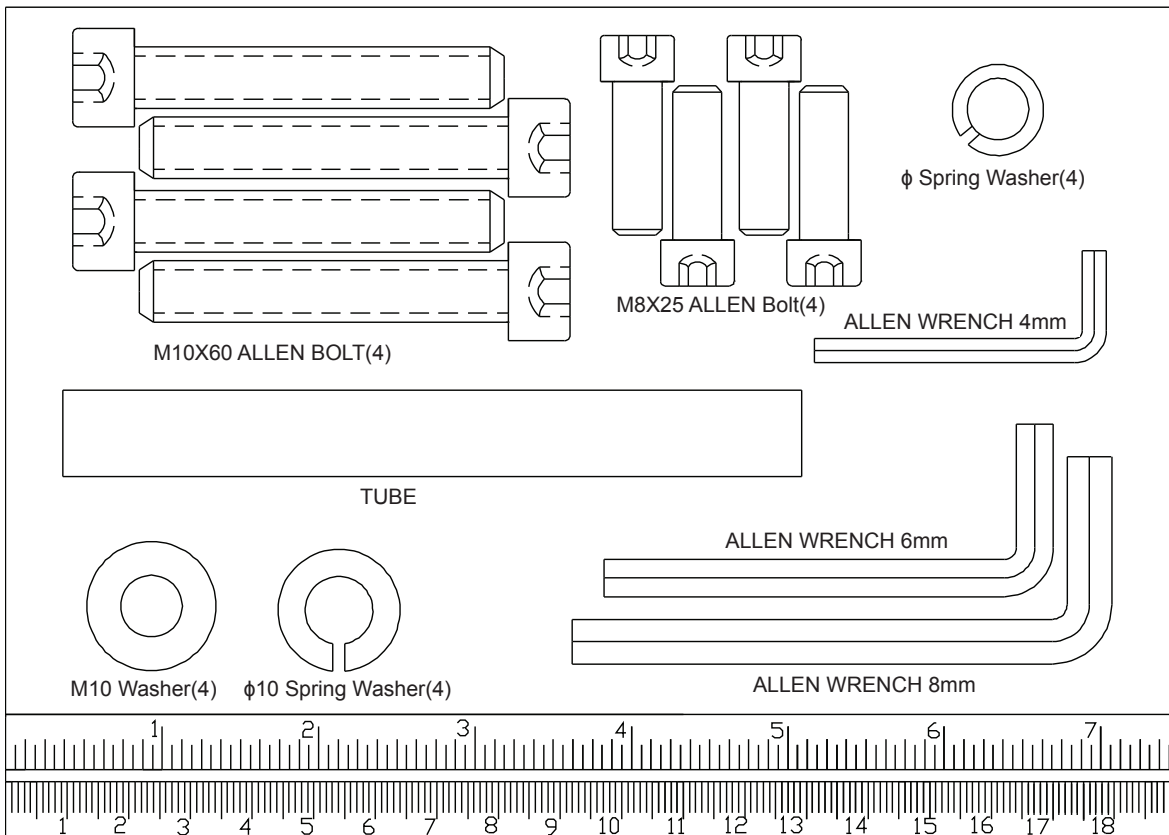
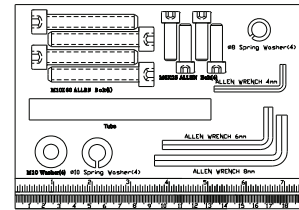

## STEP 1 - INSTALL THE COLUMN ONTO THE PLATE

Position the platform as shown in Figure 2, resting on a stable, sturdy table (at least two people are needed for this step). When fitting the column, one person should hold the column while the other follows the assembly instructions.

Place the Column near the Plate and proceed to connect the wire connectors from the Column to the wire connectors of the Plate.

Affix the Column to the Plate, put the wheel bracket under the underpan of the front holes, secure it with the Washers, Spring Washers and Bolts provided, (4 pcs of M10x40 Bolts, 4 pcs of  $\varnothing$ 10 Washers and 4 pcs  $\varnothing$ 10 Spring Washers).

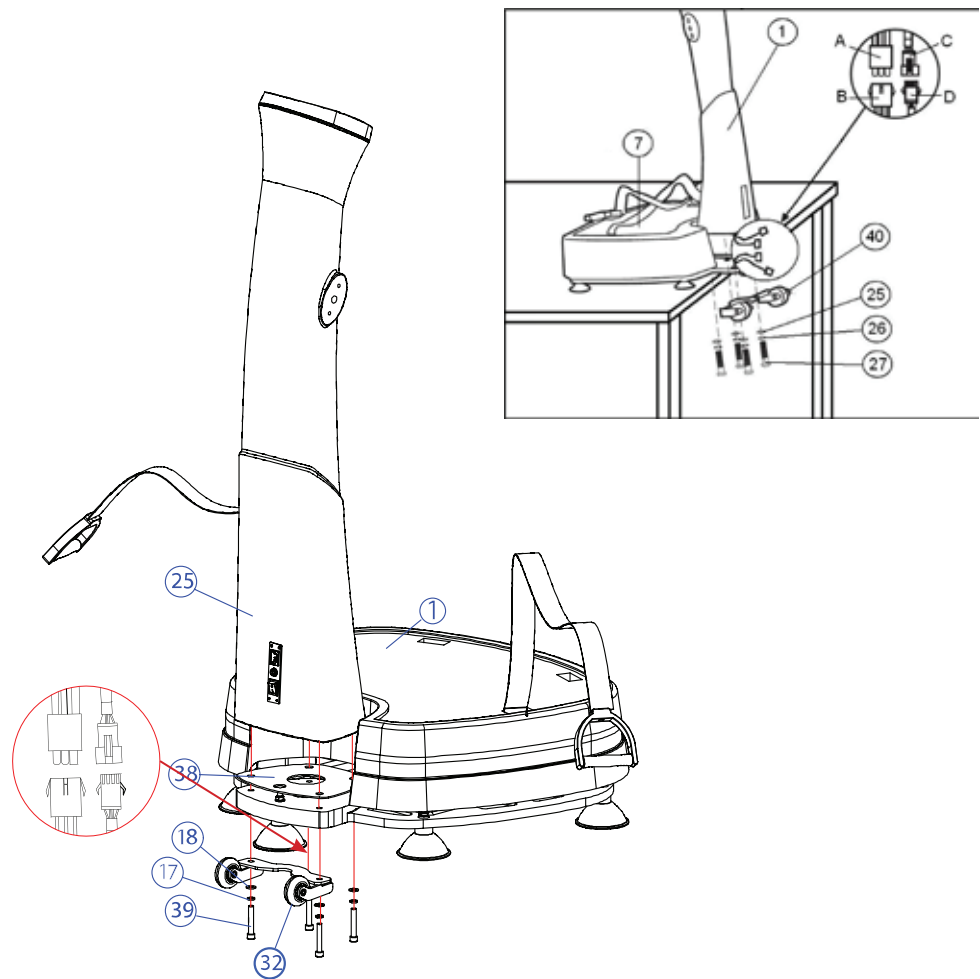

## STEP 2 - ATTACH THE HANDLE BAR TO THE COLUMN.

Align the holes on the Handlebar to the holes in the Column.

Attach the Handlebar to the Column with the Spring Washers and Bolts provided (2 M8x25 Bolts and 2 ø8 Spring Washers).

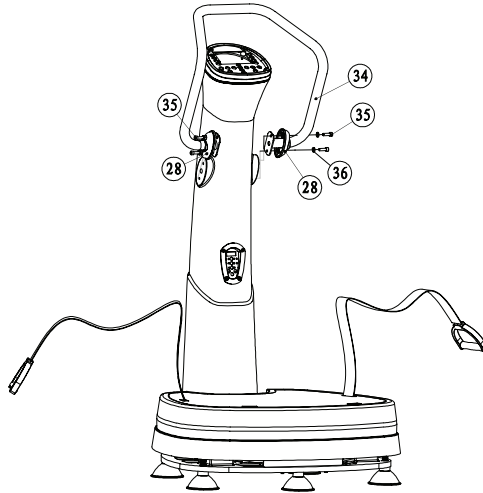

### START-UP

Plug the power cord (35) into the vibration machine on the column, and then the other end of the cord into an electrical outlet (110V). Turn the vibration machine on.

### TRANSPORT & STORAGE

The vibration machine is equipped with wheels, to make it easier to move. Make sure that the power cord is unplugged from the electrical outlet before moving the vibration machine. To prevent accidents **DO NOT** move the platform across uneven floors.

### INSPECTION & MAINTENANCE

Switch the vibration machine off and unplug the power cord. Use a damp cloth or towel to clean the dust off the platform, especially the handrails and the electronic console. Do not use solvents.

### ATTENTION:

Periodically check that all of the fastening elements are tightened and connected correctly. Check and tighten all the parts on your unit every three months. If you have any questions about any part of the vibration machine, please contact BH North America (see last page in manual). Only use original spare parts to replace any worn components. The use of other spare parts may affect the performance of the vibration machine or cause injury.



## CONSOLE OVERVIEW

### Auxiliary Column Keypad

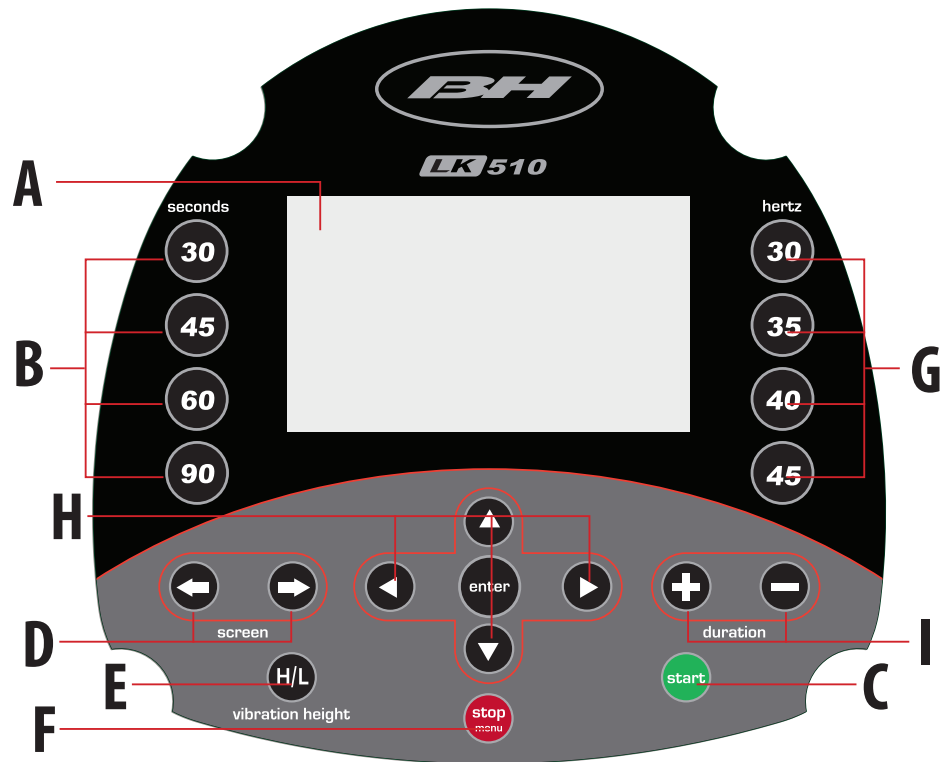
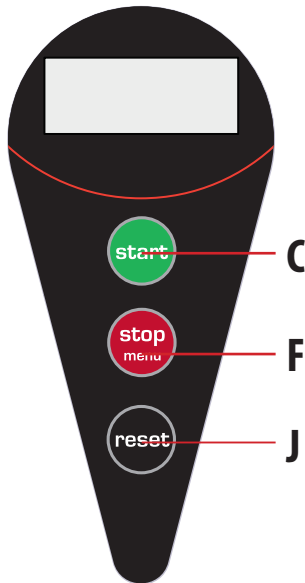

A: This display shows information about the current exercise.

B: Time Settings - buttons for specific time settings (30-45-60-90 seconds).

C: START - This starts the program.

D: Forward/Backward - buttons to move between screens.

E: H/L - by pressing this button you will toggle between the high "H" and low "L" vertical displacement settings.

F: STOP/MENU - Button to stop the vibration machine if it is operating or to return to the main menu if it is stopped.

G: Frequency Settings - buttons for selecting specific frequency settings (30Hz.-35Hz.-40Hz.-45Hz).

H: ENTER, HORIZONTAL and VERTICAL buttons.

I: +/- buttons to increase or decrease the frequency/time.

J: Reset - to reset the vibration machine.

# CONSOLE OPERATIONS

## Workouts:

Upon powering up, the console will display the default main menu items: Quick Start, Manual, Programs, and Sports.



Figure 1: Main Menu

## QUICK START

Use  $\triangle$   $\nabla$  buttons to highlight the selection. After pressing ENTER at the red highlighted QUICK START on the main menu (fig. 1), the next workout screen offers parameters (Duration, Vibrating height, Vibrating frequency).

1. Press H/L button to change vertical displacement to High or Low.
2. Time can be set using the SECONDS buttons on the left side of the LCD display for 30S, 45S, 60S, or 90S. Alternately, Press the Duration +/- buttons to change the Time by 1 second increments.
3. Vibrating frequency can be set using the HERTZ buttons on the right side of the LCD display for 30Hz, 40Hz, 40Hz, or 45Hz.

Press START to begin the workout. Once the START button is pressed, the timer starts counting down and the user cannot change the time setting. During the workout the vibrating frequency can be increased or decreased with the Duration +/- buttons by 1hz with each button press.

30S	L	30Hz
30S		30Hz
45S		35Hz
60S		40Hz
90S		45Hz

Figure 3: Quick Start default parameters

As seen in Figure 3, the header displays the set parameters of 30 seconds for Time, Low (L) for Vibration Height, and 30 Hertz for Vibration frequency. The left column under the header shows the values of seconds corresponding to the quick access time choices on the console. The right column shows the values of Hertz corresponding to the quick access frequency choices.

Figure 2:  
Console



## MANUAL

1. With the  $\triangle$   $\nabla$  buttons, highlight 'MANUAL' on the workout menu and press ENTER to accept. Select a suitable level from the menu in figure 4 and press ENTER to bring up the next screen.
2. The types of Workout screen will appear and includes: Strength, Massage, Stretching, and Low Impact (figure 5). The following steps are applicable to Strength, Massage & Stretching.
3. Highlight the desired type of Workout using  $\triangle$   $\nabla$  buttons then press ENTER to accept.



Figure 4: Workout Level



Figure 5: Types of Workouts

4. Browse with  $\triangleleft$   $\triangleright$  buttons through a collection of muscle groups. Press ENTER at a desired muscle group.

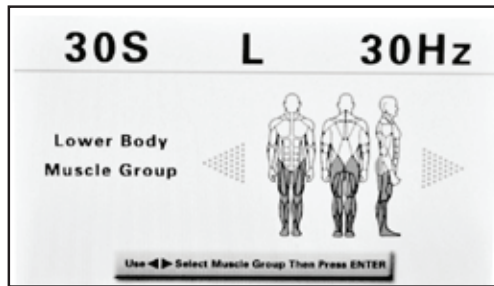

Figure 6: Muscle Group

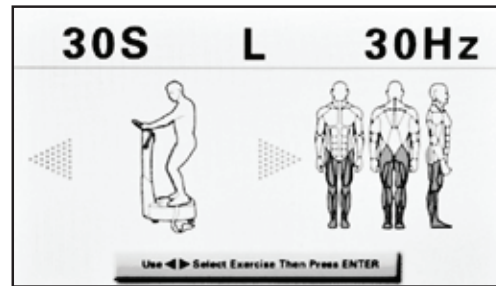

Figure 7: Exercise Posture

5. As a muscle group is selected, the corresponding posture related to the vibration machine is shown in Figure 7.

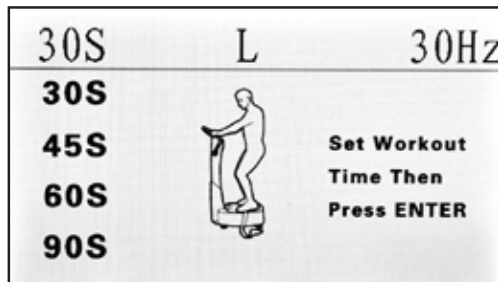

Figure 8: Time Settings

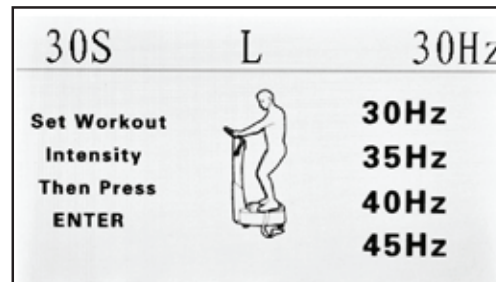

Figure 9: Intensity Settings (frequency)

6. By following the directions on the screen, the user can set Workout Time, Level (Vibration Height), and Intensity in the subsequent screens as shown in Figures 8 & 9.

- When finished setting relevant parameters, press ENTER to accept. Press START to begin the workout as seen in Figure 10 below.

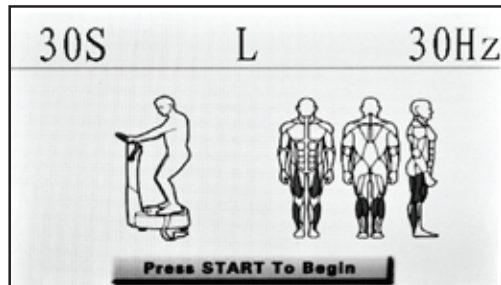

Figure 10. All Set - Press START to Begin

## PROGRAMS

With the  $\triangle$ / $\nabla$  buttons, highlight 'PROGRAMS' on the main menu and press ENTER to accept.

- Select a suitable level from the menu in Figure 4 and press ENTER to bring up the next screen.
- Types of Workout will appear which include: Strength, Massage, Stretching, and Low Impact (Figure 5). The following steps are applicable to Strength, Massage & Stretching.
- Highlight the desired Type of Workout using  $\triangle$ / $\nabla$  buttons then press ENTER to accept.
- Browse with  $\triangleleft$ / $\triangleright$  buttons through a collection of muscle groups. Press ENTER at a desired muscle group to accept.
- As a muscle group is selected, the corresponding posture related to the vibration machine shown in Figure 7.
- At this point in PROGRAMS, there is no more input asked of the user: Workout Time is preset, Level (Vibration Height) and Intensity are pre-programmed according to the Level chosen by user in step 1 above.

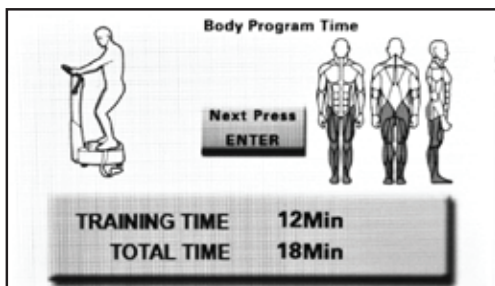

Figure 11: Program Workout Preset Details

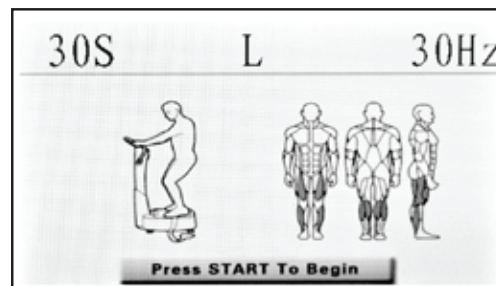

Figure 12: All Set and Ready

### NOTE:

At any point of setting up parameters or selection options, the user can go back to the previous screen by pressing the SCREEN  $\blackleftarrow$   $\blackrightarrow$  buttons.

As seen in Figure 11, there is a Training Time and a Total Time. Training Time is the time when there are bursts of vibration. During these bursts, there are rest periods in between. Together, they add up to Total Time.

## SPORTS

With the  $\triangle$  $\nabla$  buttons, highlight 'SPORTS' on the main menu and press ENTER to accept.

1. Select a suitable level from the menu in Figure 4 and press ENTER to bring up the next screen.
2. The screen displays a variety of sports available for selection (Figure 13). There are multiple screens with example as shown below (Note: Your vibration machine has the latest software version, and the sports may be in a different order than shown).



Figure 13: Types of Sports Screen 1



Figure 14: Types of Sports Screen 2



Figure 15: Types of Sports Screen 3

2. Highlight the desired sport using  $\triangleleft$  $\triangleright$  $\triangle$  $\nabla$  buttons then press ENTER to accept.
3. To access screen 2 from screen 1, press the arrows in step 2 repeatedly to advance to the next sport item. As it reaches the last item on the current page, pressing the right arrow brings up the next screen and so on to the next screen.
4. Browse the sports with  $\triangleleft$  $\triangleright$  $\triangle$  $\nabla$  arrows buttons and press ENTER to accept.
5. Related information is displayed as in Figure 16.

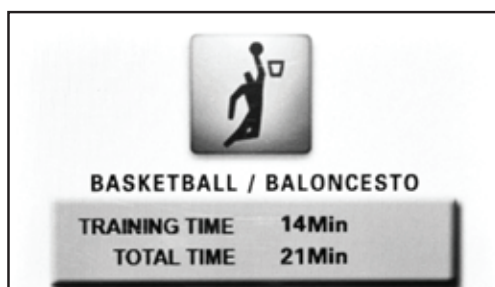

Figure 16: All Set and Ready

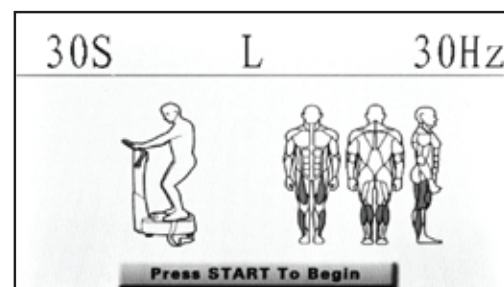

Figure 17: Muscle Group of Related Sport

6. As a sport is selected (Figure 15), the program displays the corresponding muscle group involved for user information (Figure 17).
7. At this point in SPORTS, there is no more input asked of the user: Workout Time is preset, Level (Vibration Height) and Intensity are pre-programmed according to Level chosen by user in step 1 above and muscle group is also preset according to the selected sport.
8. Press START to begin the workout.

#### GENERAL RULES:

- No training is recommended to consist of more than 12 series in a single session.
- 48 hours must elapse between two training sessions.
- **VERY IMPORTANT:** if you have never trained on a vibration platform, before you start using any of the 3 default programs, you should use the platform in manual mode until your body gets used to the vibrations. Perform 8 sets of 30 seconds, 30 seconds of recovery between sets, with four minutes of rest in the middle of the entire training session, until you feel that your body is accustomed to the vibration and do not feel discomfort or dizziness.
- In addition, it is essential that before you start to train, you read the "Exercise Guide" where you will find more information on how to use the vibration platform of other frequently asked questions, tips for use, etc.

**BH RESERVES THE RIGHT TO MODIFY THE SPECIFICATIONS ALONG WITH OTHER PRODUCTS WITHOUT PRIOR NOTICE.**

# EXPLODED VIEW DRAWING

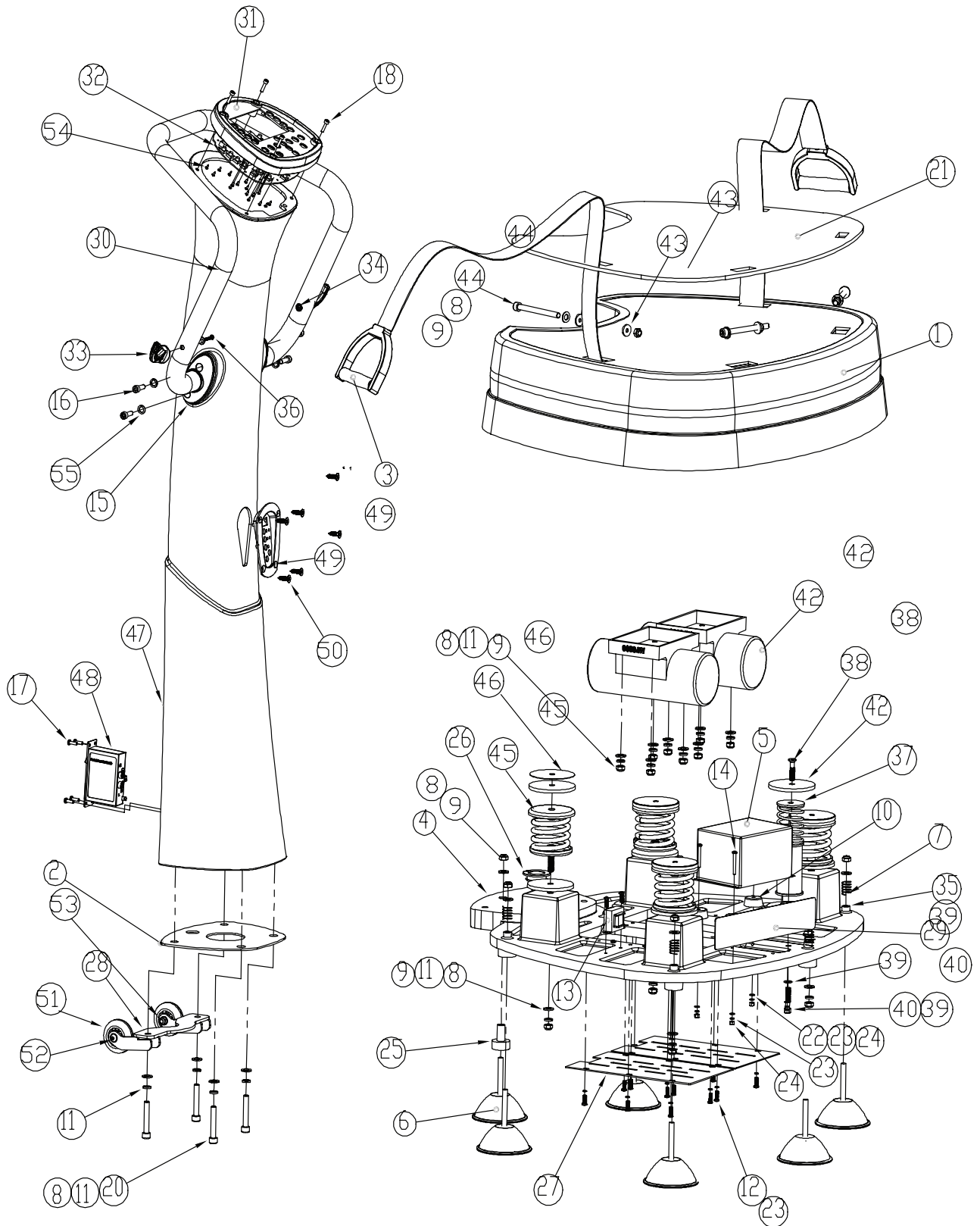

## PARTS LIST

NO.	Description	QTY	No.	Description	QTY
1	Plate	1	31	Console cover	1
2	Cushion for column	1	32	Monitor PCB	1
3	Hand strap	2	33	Hook	2
4	Underpan	1	34	Hook sleeve	2
5	Transducer	1	35	Rubber sleeve	5
6	Suction cup	6	36	Sheet metal screw st4.2*32	2
7	Small Spring	6	37	Spring	1
8	Washer M10	18	38	Allen head bolt M10X40	1
9	Nylon nut M10	21	39	Washer	5
10	Cushion for transducer	4	40	Allen bolt M8x8	1
11	Spring washer M10	16	41	Spring washer	10
12	Cross head bolt M5x15L	22	42	Motor	2
13	Reactor	1	43	Rubber washer $\phi$ 10	8
14	Cross head bolt M5x40L	4	44	Allen bolt M10*110	4
15	Handlebar cover	2	45	Big spring	4
16	Allen head bolt M8X25	4	46	Paper washer	5
17	Cross head bolt M5x15L	4	47	Column	1
18	Allen bolt M5X20L	4	48	Power Panel	1
20	Allen head bolt M10X60	4	49	Lower console	1
21	Non-slip mat	1	50	Sheet metal screw St4.8*12	4
22	Washer M5	6	51	Wheel	2
23	Spring washer M5	22	52	Allen bolt M8*50	2
24	Nylon nut M5	4	53	Nylon nut M8	2
25	Rubber sleeve	1	54	Sheet metal screw St3*8	24
26	Rubber ring	1	55	Spring washer M8	4
27	Motor cover	2			
28	Wheel bracket	1		$\phi$ = Diameter	
29	Protect bracket	1			
30	Handlebar	1			



## WARRANTY

### LIGHT COMMERCIAL WARRANTY

BH North America will repair or replace, free of charge, at its option, parts that are defective as a result of material or workmanship. Five (5) years warranty coverage on frame and Two (2) years on other parts. Labor warranty coverage is Two (2) years. Warranty covers the original consumer purchaser only.

### RESIDENTIAL WARRANTY

BH North America will repair or replace, free of charge, at its option, parts that are defective as a result of material or workmanship. Lifetime replacement warranty coverage on frame and Two (2) years on other parts. Labor warranty coverage is Two (2) years. Warranty covers the original consumer purchaser only.

### THIS WARRANTY DOES NOT COVER

- Pre-delivery set-up.
- Components that require replacement due to dirt or lack of regular maintenance.
- Expendable items which become worn during normal use.
- Repairs necessary because of operator abuse or negligence or the failure to operate and maintain the equipment according to the instructions contained in the Owner's Manual.

For more detailed warranty information or to register your product warranty easily online, visit our website at: [www.BHFitnessUSA.com](http://www.BHFitnessUSA.com)

**FOR WARRANTY REPAIRS, PLEASE DO NOT TAKE YOUR MACHINE  
BACK TO THE RETAIL STORE. CONTACT BH FITNESS FIRST.**

BH North America Corporation  
20155 Ellipse  
Foothill Ranch, CA 92610

Phone: 949.206.0330; Toll Free: 866.325.2339; Fax: 949.206.0013

Web: [www.BHFitnessUSA.com](http://www.BHFitnessUSA.com)

Mon - Fri 8am - 5pm PST