



User Manual

905U-G Wireless Gateway

ELPRO Technologies Pty Ltd, 9/12 Billabong Street, Stafford Q 4053, Australia.

Tel: +61 7 33524533 Fax: +61 7 33524577 Email: sales@elprotech.com

Web: www.elprotech.com

Thank you for your selection of the 905G module. We trust it will give you many years of valuable service.

ATTENTION!

Incorrect termination of supply wires may cause internal damage and will void warranty.

To ensure your 905G enjoys a long life,

**double check ALL your connections with
the user's manual**

before turning the power on.

Caution!

For continued protection against risk of fire, replace the module fuse F1 only with the same type and rating.

CAUTION:

To comply with FCC RF Exposure requirements in section 1.1310 of the FCC Rules, antennas used with this device must be installed to **provide a separation distance of at least 20 cm from all persons** to satisfy RF exposure compliance.

DO NOT:

- operate the transmitter when someone is within 20 cm of the antenna
- operate the transmitter unless all RF connectors are secure and any open connectors are properly terminated.
- operate the equipment near electrical blasting caps or in an explosive atmosphere

All equipment must be properly grounded for safe operations. All equipment should be serviced only by a qualified technician.

FCC Notice:

This user's manual is for the ELPRO 905U-G radio telemetry module. This device complies with Part 15.247 of the FCC Rules.

Operation is subject to the following two conditions:

- 1) This device may not cause harmful interference and
- 2) This device must accept any interference received, including interference that may cause undesired operation.

This device must be operated as supplied by ELPRO Technologies Pty Ltd. Any changes or modifications made to the device without the written consent of ELPRO Technologies Pty. Ltd. May void the user's authority to operate the device.

End user products that have this device embedded must be supplied with non-standard antenna connectors, and antennas available from vendors specified by ELPRO Technologies. Please contact ELPRO Technologies for end user antenna and connector recommendations.

Notices: Safety

Exposure to RF energy is an important safety consideration. The FCC has adopted a safety standard for human exposure to radio frequency electromagnetic energy emitted by FCC regulated equipment as a result of its actions in Docket 93-62 and OET Bulletin 65 Edition 97-01.

CAUTION:

To comply with FCC RF Exposure requirements in section 1.1310 of the FCC Rules, antennas used with this device must be installed to provide a separation distance of at least 20 cm from all persons to satisfy RF exposure compliance.

DO NOT:

- operate the transmitter when someone is within 20 cm of the antenna
- operate the transmitter unless all RF connectors are secure and any open connectors are properly terminated.
- operate the equipment near electrical blasting caps or in an explosive atmosphere

All equipment must be properly grounded for safe operations. All equipment should be serviced only by a qualified technician.

Important Notice

ELPRO products are designed to be used in industrial environments, by experienced industrial engineering personnel with adequate knowledge of safety design considerations.

ELPRO radio products are used on unprotected license-free radio bands with radio noise and interference. The products are designed to operate in the presence of noise and interference, however in an extreme case, radio noise and interference could cause product operation delays or operation failure. Like all industrial electronic products, ELPRO products can fail in a variety of modes due to misuse, age, or malfunction. We recommend that users and designers design systems using design techniques intended to prevent personal injury or damage during product operation, and provide failure tolerant systems to prevent personal injury or damage in the event of product failure. Designers must warn users of the equipment or systems if adequate protection against failure has not been included in the system design. Designers must include this Important Notice in operating procedures and system manuals.

These products should not be used in non-industrial applications, or life-support systems, without consulting ELPRO Technologies first.

1. For 905G modules, a radio license is not required in most countries, provided the module is installed using the aerial and equipment configuration described in the *905U Installation Guide*. Check with your local 905G distributor for further information on regulations.
2. For 905G modules, operation is authorized by the radio frequency regulatory authority in your country on a non-protection basis. Although all care is taken in the design of these units, there is no responsibility taken for sources of external interference. The 905U intelligent communications protocol aims to correct communication errors due to interference and to retransmit the required output conditions regularly. However some delay in the operation of outputs may occur during periods of interference. Systems should be designed to be tolerant of these delays.
3. To avoid the risk of electrocution, the aerial, aerial cable, serial cables and all terminals of the 905G module should be electrically protected. To provide maximum surge and lightning protection, the module should be connected to a suitable earth and the aerial, aerial cable, serial cables and the module should be installed as recommended in the *Installation Guide*.
4. To avoid accidents during maintenance or adjustment of remotely controlled equipment, all equipment should be first disconnected from the 905U module during these adjustments. Equipment should carry clear markings to indicate remote or automatic operation. E.g. "This equipment is remotely controlled and may start without warning. Isolate at the switchboard before attempting adjustments."
5. The 905G module is not suitable for use in explosive environments without additional protection.

Limited Warranty, Disclaimer and Limitation of Remedies

ELPRO products are warranted to be free from manufacturing defects for a period of 2 years from the effective date of purchase. The effective date of purchase is decided solely by ELPRO Technologies.

This warranty does not extend to:

- failures caused by the operation of the equipment outside the particular product's specification, or
- use of the module not in accordance with this User Manual, or
- abuse, misuse, neglect or damage by external causes, or
- repairs, alterations, or modifications undertaken other than by an authorized Service Agent.

ELPRO's liability under this warranty is limited to the replacement or repair of the product. This warranty is in lieu of and exclusive of all other warranties. This warranty does not indemnify the purchaser of products for any consequential claim for damages or loss of operations or profits and ELPRO is not liable for any consequential damages or loss of operations or profits resulting from the use of these products. ELPRO is not liable for damages, losses, costs, injury or harm incurred as a consequence of any representations, warranties or conditions made by ELPRO or its representatives or by any other party, except as expressed solely in this document.

How to Use This Manual

To receive the maximum benefit from your 905G product, please read the **Introduction**, **Installation** and **Operation** chapters of this manual thoroughly before using the 905G.

Chapter Four **Configuration** explains how to configure the modules using the Configuration Software available.

Chapter Six **Troubleshooting** will help if your system has problems.

The foldout sheet *905U-G Installation Guide* is an installation drawing appropriate for most applications.

CONTENTS

CHAPTER 1 INTRODUCTION	9
1.1 905G OVERVIEW	9
1.1.1 Modbus / DF1 905G	10
1.1.2 Profibus 905G	10
1.1.3 Ethernet 905G	11
1.1.4 DeviceNet 905G	12
1.1.5 Modbus Plus 905G	12
1.2 THE 905G STRUCTURE	13
1.2.1 On-board I/O	14
1.2.2 I/O Expansion - 105S modules	14
1.3 THE WIRELESS NETWORK	14
1.3.1 905U to 905G Network	14
1.3.2 905G to 905G Network	15
1.3.3 “Data Concentrator” Networks	16
1.3.4 905G Repeaters	17
CHAPTER 2 OPERATION	19
2.1 START-UP	19
2.2 OPERATION	19
2.3 DATABASE	21
2.4 THE HOST - 905G LINK	22
2.4.1 Modbus / DF1	22
2.4.2 Profibus	23
2.4.3 Ethernet	23
2.5 RADIO SYSTEM DESIGN	23
2.5.1 Radio Signal Strength	24
2.5.2 Repeaters	24
2.6 RADIO COMMS FAILURE	24
2.6.1 Monitoring Communications Failure	25
2.7 SECURITY CONSIDERATIONS	26
CHAPTER 3 INSTALLATION	27
3.1 GENERAL	27
3.2 ANTENNA INSTALLATION	27
Dipole and Collinear antennas.	29
3.2.2 Yagi antennas.	29
3.3 POWER SUPPLY	33
3.3.1 AC Supply	33
3.3.2 DC Supply	33
3.3.3 Solar Supply	33
3.4 INPUT / OUTPUT	33
3.4.1 Digital Inputs / Outputs	33
3.5 SERIAL PORT	33
3.5.1 RS232 Serial Port	33
3.5.2 RS485 Serial Port	34
3.6 PROFIBUS PORT	36
3.7 ETHERNET PORT	37
3.8 MODBUS PLUS PORT	38
3.9 DEVICENET PORT	39
CHAPTER 4 CONFIGURATION	41
4.1 INTRODUCTION	41
4.2 CONFIGURATION PROGRAM	42
Program Operation	42

4.2.2	Security	46
4.3	MAPPINGS 905G TO 905U I/O MODULES	48
4.3.1	Mappings from Inputs at Remote 905U I/O Modules	48
4.3.2	Mappings from 905G to Outputs at Remote 905U I/O Modules	50
4.3.3	Don't Send if in Comm Fail	52
4.3.4	Startup Polls	53
4.3.5	Polls to Remote Modules	53
4.4	MAPPINGS FROM 905G TO OTHER 905G MODULES	53
4.4.1	Entering a Block Mapping	55
4.4.2	Host Device Trigger	56
4.4.3	Time Period	57
4.4.4	Real-Time	58
	Change-of-State	60
4.4.6	Mixing Normal Mappings and Block Mappings	60
4.4.7	Comms Fail for Block Mappings	60
	"Repeater-only" Configuration	61
4.5	CHANGE SENSITIVITY	61
4.6	SERIAL CONFIGURATION - MODBUS	63
4.6.1	MODBUS Slave	63
4.6.2	MODBUS Master	65
4.7	SERIAL CONFIGURATION - DF1	68
4.8	FIELDBUS CONFIGURATION	73
	Fieldbus Mappings	74
4.9	FIELDBUS CONFIGURATION - PROFIBUS SLAVE	79
4.10	FIELDBUS CONFIGURATION - PROFIBUS MASTER	80
4.10.1	GSD File	80
4.10.2	Protocol and Supported Functions	80
4.10.3	Configuration	81
4.10.4	Message Interface	92
	Error Codes	112
	DPV1 Return Codes	113
4.11	FIELDBUS CONFIGURATION - ETHERNET	113
4.11.1	Setting IP Address	114
4.11.2	Modbus TCP	116
4.11.3	EtherNet/IP	119
4.12	FIELDBUS CONFIGURATION – DEVICENET	123
4.12.1	DeviceNet Introduction	123
4.12.2	DeviceNet Address Setting	123
4.12.3	EDS File	123
4.12.4	Protocol and Supported Functions	124
4.13	FIELDBUS CONFIGURATION – MODBUS PLUS	124
4.13.1	Modbus Plus Introduction	124
4.13.2	Modbus Plus Addressing	124
4.13.3	Protocol & Supported Functions	125
4.13.4	Configuration	126
4.14	CONNECTING 105S SERIAL I/O	128
4.15	UPLOADING AND DOWNLOADING	129
4.15.1	Loading from a 905G	129
CHAPTER 5 SPECIFICATIONS		131
CHAPTER 6 DIAGNOSTICS		133
6.1	DIAGNOSTICS CHART	133
6.2	DIAGNOSTICS MENU	134
6.3	ETHERNET DIAGNOSTICS	141

6.4	FIELD BUS INDICATING LEDES	143
	CHAPTER 7 WARRANTY	149
	APPENDIX 1 STATUS REGISTERS	151
	APPENDIX 2 IT FUNCTIONALITY	153

Chapter 1

INTRODUCTION

1.1 905G Overview

The 905U-G Wireless Gateway products provide a wireless interface between various fieldbus protocols used in process and automation applications. The 905U-G includes an integral 900MHz license-free radio transceiver, and transfers transducer and control signals (I/O) using a highly secure and highly reliable radio protocol.

The 905U radio protocol is designed for very efficient radio band usage, with event reporting communications, automatic acknowledgment and error-correction, peer to peer addressing, multiple path routing, and frequency encoding and data encryption for system security.

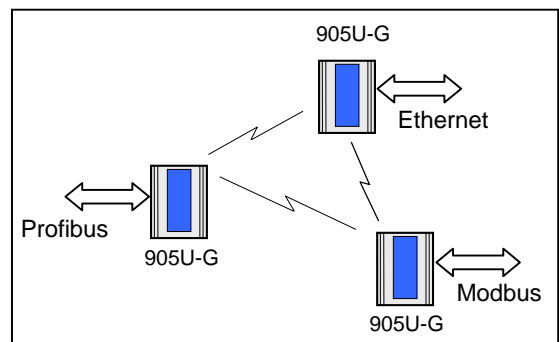
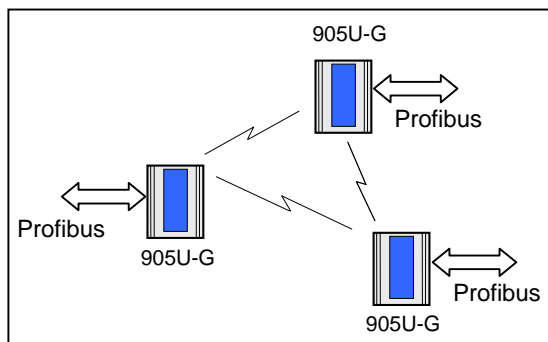
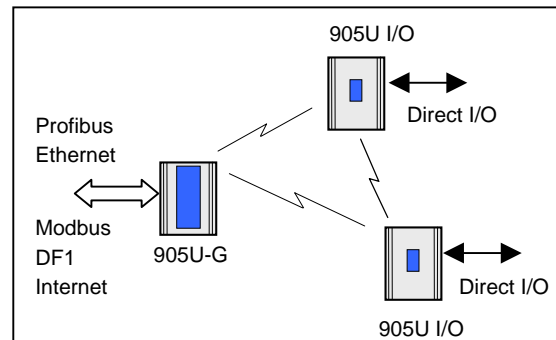

Application types include:

- The 905U-G interfaces between 905U wireless I/O and various fieldbus protocols. Connect wireless I/O to PLC's, DCS, SCADA or Internet.
- Wireless extension of factory automation buses such as Profibus.
- Wireless interconnectivity between different fieldbuses - Ethernet to Profibus to Modbus to DF1.
- Combined networks of the above.

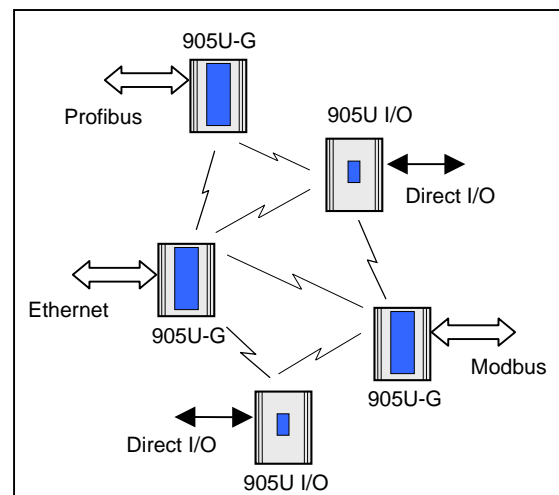

The 905U-G has eight on-board discrete I/O. Each I/O point can be configured individually as a contact input signal, or a discrete output signal. Input signals can sent via its fieldbus connection to a host device (PLC, DCS etc) or be transmitted by radio to other 905U units. The output signals can be driven by a host device, or linked to inputs on remote 905U units.

This document assumes the reader is familiar with the operation of the 905U I/O modules - for further information, please refer to the User Manuals for these products.

The 905U-G is referred to as the 905G for the rest of this document, to clearly differentiate from normal 905U I/O modules.

Ordering information:

905U-G-MD1	Modbus Master & Slave / DF1 interface
905U-G-PR1	Profibus-DP Slave interface
905U-G-PR2	Profibus-DP Master interface
905U-G-ET1	Ethernet interface - Modbus TCP, Ethernet IP, FTP, HTML, Email
905U-G-DE1	DeviceNet Slave interface
905U-G-M+1	Modbus Plus Slave interface

1.1.1 Modbus / DF1 905G

The 905U-G-MD1 can be configured for Modbus master interface, Modbus slave, or DF1.

Modbus is a Master-Slave protocol originally developed by Modicon (now part of the Schneider group). It became a popular interconnect protocol with many equipment manufacturers. One Modbus master controls the Modbus network communications, which can comprise up to 250 Modbus slave devices. The Modbus master can read or write I/O values to/from Modbus slaves. The 905G can be configured as either Modbus Master or Modbus Slave. The variation of Modbus supported by the 905G is “Modbus RTU” (also known as “Modbus binary”).

DF1 is an Allen-Bradley protocol (Allen-Bradley is now part of the Rockwell Automation group). DF1 offers both full-duplex (point to point) and half-duplex (multidrop) operation. The 905G only supports the full-duplex operation - this is the default DF1 mode on most equipment. DF1 full-duplex is a “peer-to-peer” protocol. Either DF1 device can initiate commands to the other device, and both devices will respond to commands from the other device.

The 905U-G-MD1 has two serial connections - RS232 and RS485, on the bottom end plate of the module. The serial port provides both RS232 and RS485 hardware connections, however both connections are paralleled internally - both connections cannot be used at the same time. Either RS232 or RS485 can be used for Modbus communications, **however only the RS232 port can be used for DF1**. The serial port must be configured to suit the host device. Serial data rates between 1200 and 19200 baud may be selected, and character types with 7 or 8 data bits, even/odd/none parity, and 1 or 2 stop bits may be selected.

The Modbus/DF1 905G has 4300 general-purpose I/O registers. Each discrete, analog and pulse I/O point takes up one register.

1.1.2 Profibus 905G

The Profibus 905G provides Profibus-DP Slave functionality according to EN 50170. Profibus is a popular automation fieldbus that originated in Germany and is used extensively by Siemens and other automation suppliers.

The Profibus connection on the 905G is optically isolated RS485 using an on-board DC/DC converter. The Profibus port has automatic baudrate detection (9600 bit/s - 12 Mbit/s).

The Profibus Slave 905G (PR1) will connect to a Profibus LAN controlled by an external master device. The Profibus Master 905G (PR2) will control communications on a Profibus LAN, and can connect to up to 125 Profibus slave devices.

The Profibus 905G I/O database has 4300 registers (each of 16 bit value), however the Profibus interface limits the amount of I/O that can be transferred via the Profibus port.

Slave unit (PR1). The PR1 slave unit only supports 416 x 8 bit bytes of I/O. Of the 416 bytes of I/O, there is a maximum 244 input bytes and maximum 244 output bytes - that is, if 244 input bytes are used then only 172 output bytes can be used (416 – 244). Each byte can represent 8 discrete inputs or outputs, or an 8-bit value, or two bytes can represent a 16-bit value. That is, analog or pulse I/O can be transferred as 8-bit registers (1 byte) or 16-bit registers (2 consecutive bytes).

An “output” is a value coming into the 905G via the fieldbus (that is, a value written to the 905G from the Profibus master). An input is a value going out from the 905G via the fieldbus (a value read by the Profibus master).

So a Profibus Slave 905G could handle up to 1952 (244 x 8) discrete inputs or 244 low resolution analog inputs or 122 (244 x ½) high resolution analog inputs, or some combination in between.

For example, a Profibus 905G can handle 400 discrete inputs, 240 discrete outputs, 90 analog inputs and 60 analog outputs (assume analogs are 16-bit). The number of input bytes is 230 (400/8 + 90*2). The number of output bytes is 150 (240/8 + 60*2). The total number of I/O bytes is 380. If the number of analog outputs was increased to 90, then the total output bytes would be 210 (240/8 + 90*2), and the total number of I/O bytes is 440 - this exceeds the capacity of the Profibus interface.

Master unit (PR2). The Profibus master interface supports 2048 input bytes and 2048 output bytes. Each byte can be 8 discrete inputs or outputs, but analog or pulse I/O take up 1 byte for low resolution values (8-bit) or 2 bytes for high resolution values (16-bit).

So a Profibus Master 905G can handle up to 4300 I/O total, but analog or pulse inputs are limited to 2048 x 8-bit values or 1024 x 16-bit values. The same limit applies to outputs.

For example, a Profibus Master 905G can handle 2000 discrete inputs and 500 analog inputs (assume analogs are 16-bit). The number of input bytes is 1250 (2000/8 + 500*2). The same unit could handle 4000 discrete outputs and 750 analog outputs. The number of output bytes is 2000 (4000/8 + 750*2). The total number of I/O is 3250 which is less than the total limit of 4300.

1.1.3 Ethernet 905G

The Ethernet 905G provides several different types of Ethernet functionality:

- ◆ Modbus TCP. Modbus TCP uses Modbus as a base protocol within an Ethernet communications structure. The 905G provides class 0, 1 and partially class 2 slave functionality.
- ◆ EtherNet IP. EtherNet IP is the version of Ethernet used by Allen-Bradley devices. The 905G provides level 2 I/O server CIP (ControlNet and DeviceNet).
- ◆ Internet functionality. The 905G has 1.4Mbyte of non-volatile “flash” memory for embedded web “pages” (dynamic HTTP), on-board file system, user downloadable web pages thru FTP server, and email functionality (SMTP).

The Ethernet connection is a transformer isolated RJ45 connector, 10/100 Mbit/sec.

The Ethernet 905G I/O database has 4300 registers (each of 16 bit value), however the Ethernet interface only supports 2048 input bytes and maximum 2048 output bytes. Each

byte can be 8 discrete inputs or outputs, but analog or pulse I/O take up 1 byte for low resolution values (8-bit) or 2 bytes for high resolution values (16-bit).

An “output” is a value coming into the 905G via the fieldbus. An input is a value going out from the 905G via the fieldbus.

So an Ethernet 905G can handle up to 4300 I/O total, but analog or pulse inputs are limited to 2048 x 8-bit values or 1024 x 16-bit values. The same limit applies to outputs.

For example, an Ethernet 905G can handle 2000 discrete inputs and 500 analog inputs (assume analogs are 16-bit). The number of input bytes is 1250 ($2000/8 + 500*2$). The same unit could handle 4000 discrete outputs and 750 analog outputs. The number of output bytes is 2000 ($4000/8 + 750*2$). The total number of I/O is 3250 which is less than the total limit of 4300.

1.1.4 DeviceNet 905G

The DeviceNet 905G provides DeviceNet 2.0 Slave functionality. DeviceNet is an automation fieldbus developed by Allen-Bradley (Rockwell Automation).

The DeviceNet connection on the 905G is optically isolated RS422 with selectable baudrate between 125 and 500 Kbit/sec.

The 905G I/O database has 4300 registers (each of 16 bit value), however the DeviceNet interface only supports 512 x 8 bit input bytes and 512 x 8 bit output bytes, and this limits the amount of I/O that can be transferred via the DeviceNet port.

Each byte can represent 8 discrete inputs or outputs, or an 8-bit value, or two bytes can represent a 16-bit value. That is, analog or pulse I/O can be transferred as 8-bit registers (1 byte) or 16-bit registers (2 consecutive bytes).

An “output” is a value coming into the 905G via the fieldbus (that is, a value written to the 905G from the DeviceNet master). An input is a value going out from the 905G via the fieldbus (a value read by the DeviceNet master).

So a DeviceNet 905G can normally handle up to 4096 (512×8) discrete inputs or 512 low resolution analog inputs or 256 ($512 \times 1/2$) high resolution analog inputs, or some combination in between. It can also handle the same number of outputs, however the total I/O count cannot exceed the 905G database size of 4300.

1.1.5 Modbus Plus 905G

The Modbus Plus 905G provides Modbus Plus Slave functionality. The Modbus Plus connection on the 905G is optically isolated RS485 with standard baudrate of 1 Mbit/sec.

The 905G I/O database has 4300 registers (each of 16 bit value), however the Modbus Plus interface only supports 1024 input registers and maximum 1024 output registers. Each register can be 16 discrete inputs or outputs, or one analog or counter 16-bit value.

An “output” is a value coming into the 905G via the fieldbus. An input is a value going out from the 905G via the fieldbus.

So an Modbus Plus 905G can handle up to 4300 I/O total, but analog or pulse inputs are limited to 1024 x 16-bit values. The same limit applies to outputs.

The Modbus Plus interface allows global data base transactions with routing for up to six Modbus Plus networks.

1.2 The 905G Structure

The 905G has three functional sections:

- The Radio Interface consists of an I/O database (or "Process Image") that maintains the latest values of all I/O in the wireless I/O system. The I/O database comprises 4300 x 16 bit I/O registers and 4300 x 16 bit status registers. There are also other registers in the database that can be used for system management - they are discussed later in this manual. NOTE – the terms 'Radio Interface' and 'I/O database' are used interchangeably throughout the manual.
- The radio port allows the 905G to communicate with other 905G and/or 905U modules using the 905U protocol (called "ELPRO 905U"). Messages from the 905U modules are received by the radio port and used to update the input values in the 905G Radio Interface. The radio port also creates the correct radio message to set outputs on the remote 905U modules.

The ELPRO 905U protocol is an extremely efficient protocol for radio communications. Radio messages can be sent using exception reporting - that is, when there is a change of an input signal - or by read/write messages. Each message can comprise a single I/O value, or multiple I/O values (termed a "block" of I/O). There are also update messages, which are sent for integrity purposes. Messages include error checking, with the destination address sending a return acknowledgment. Up to five attempts are made to transmit the message if an acknowledgment is not received.

The ELPRO 905U protocol is designed to provide reliable radio communications on an open license-free radio channel.

- The Fieldbus port enables communications between a host device, which could be a PLC, DCS, HMI, intelligent transducer, etc), and the 905G Radio Interface database. A "host device" may be one or several devices connected to the same fieldbus or network (for example, an Ethernet LAN) - in this manual, the LAN is considered as a "host device".

The fieldbus port decodes messages from the host device and reads or writes I/O values to the database. The fieldbus port can also generate messages to the host device.

The 905G I/O database effectively isolates the fieldbus and the radio network. This provides a high level of system performance. The 905U radio protocol is very efficient and reliable for radio communications. It minimizes radio channel usage by "change-of-state" reporting, and allows the use of intermediate repeater addresses. It also allows peer-to-peer (905U to 905U, 905G to 905G) and peer-to-master (905U to 905G) communications. PLC protocols, by comparison, are designed to provide transfer of large I/O files by "wire" link. The 905G retains the advantage of both protocols in their respective communications media.

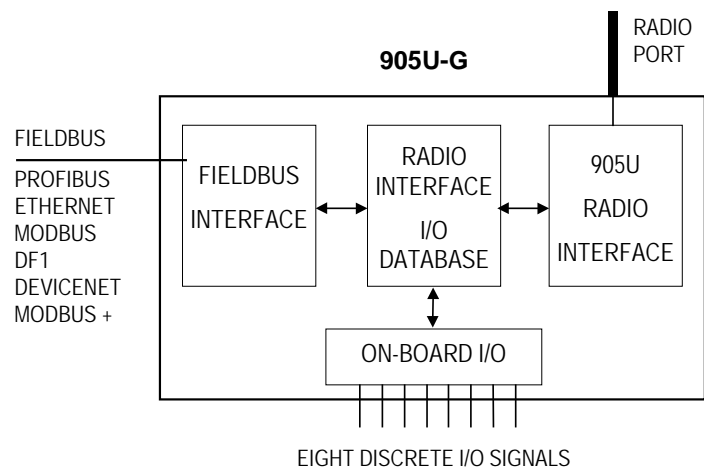

1.2.1 On-board I/O

The 905G has eight on-board discrete I/O. Each I/O point can be used as either a discrete input (voltage free contact input) or discrete output (transistor output) - an I/O point cannot be used as both input and output. Each I/O point is linked to two separate I/O registers in the database - one for the “input” function and one for the “output” function.. If the output register is set “on” by the fieldbus or by a radio message from a remote module, then the 905G will automatically set the input register for the same I/O point to “off”. This means that the output register has priority over the input register - if there is a conflict, the input value is ignored.

The 905G also has three internal inputs linked to I/O registers:

- ◆ Supply voltage status - if the normal supply fails, this status is set on.
- ◆ Low battery voltage. The 905G has an internal battery charger to trickle charge a back-up battery. If the battery voltage is low, this status is set.
- ◆ Battery voltage - the actual value of the connected battery voltage.

1.2.2 I/O Expansion - 105S modules

The 905G provides eight on-board discrete I/O. Where additional I/O is required, 105S modules can be connected to the RS485 port of the 905G modules.

Note: 105S modules cannot be connected to the 905U-G-MD1 unit (as this unit uses the RS485 port for Modbus or DF1 communications), unless this unit is configured as “Repeater-only” and does not have a host device connected.

1.3 The Wireless Network

The 905G can communicate with up to 490 other addresses - this could be 490 other 905U modules, or in the case of 905K modules, it could be many thousands of modules (as many 905K modules can share the same address). 905G modules may take up more than one address under some circumstances.

Any 905G or 905U module can act as a radio repeater for other modules - that is, radio messages can be passed onto other modules. Up to five repeater addresses can be configured for messages transmitted to a 905G module.

Each module can have a unit address between 1 – 95, but the 905G also recognizes repeater addresses in conjunction with the unit address as the module “identifier”. Hence module #2 is recognized as different to #2 via #57 - #57 being a repeater.

1.3.1 905U to 905G Network

In the wireless I/O system, the 905G acts as a normal 905U module (this covers 905U I/O, 105S I/O, 905U-K and 905U-C modules).

905U modules transmit messages to the 905G address and the 905G acknowledges these messages like a normal 905U module. When a 905G transmits messages to change remote outputs, it will "re-try" if it does not receive an acknowledgment, like a normal 905U module.

Remote 905U modules can connect to 105S modules in the normal way. The 905G host can access I/O on 105S modules by using the intermediate 905U as a repeater.

905U modules can transmit input messages directly to outputs on other 905U module, as well as the 905G. The same input can be transmitted to different addresses by entering two "mapping" configurations at the remote module.

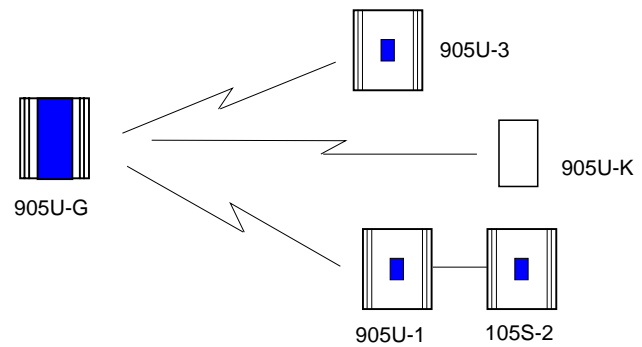

Normal 905U Messages

I/O registers in a 905G can be configured (mapped) to outputs at remote 905U modules, or I/O registers in 905G

modules. The 905G will transmit an I/O message when a “change-of-state” occurs for that I/O register. Registers have a configurable “sensitivity” value - this determines how much the register value has to change to trigger a change message. A change-of-state occurs when the register value has changed by more than the sensitivity value since the last transmission.

The 905G also transmits periodic update messages if there has been no change - if an I/O register is mapped to a remote output or another 905G, then that register can be configured with an update time.

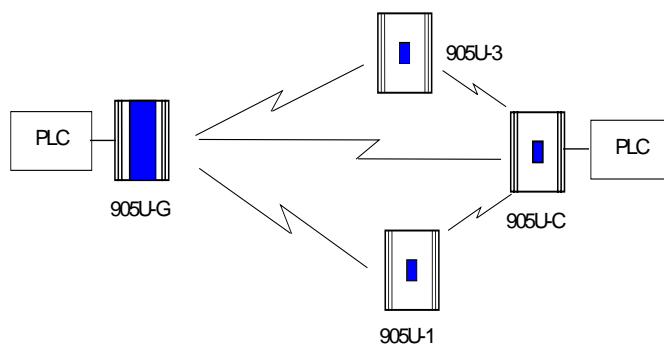

905G modules can transmit to 905G modules as well as other 905G modules. There can be multiple 905G and 905C modules in a network - as well as 905U I/O. Because the 905U protocol is peer-to-peer, there are few constraints on communications between multiple 905U modules.

Poll Messages

A 905G can also generate poll messages to remote 905U modules. These poll messages act in the same way as a start-up poll - the remote module immediately responds with update messages for any I/O mappings configured to the 905G.

Poll messages can be triggered by:

- ◆ time period, configurable 1 – 4096 sec (1.1 hour), or
- ◆ real time clock, or
- ◆ on demand by the host device, by writing to a “trigger register” in the 905G

1.3.2 905G to 905G Network

Different types of 905G modules can communicate - for example, a Modbus 905G can communicate with an Ethernet 905G. I/O registers in one 905G can be transmitted to I/O registers in another 905G. When the 905G is configured, “mappings” can be entered linking I/O registers to registers in another 905G.

As well as the normal “I/O change” messages and update messages, the 905G has “block read” and “block write” messages for use with other 905G modules. These messages will transmit multiple register values instead of only one as in the normal 905U message. The block read/write messages increase the efficiency of radio communications where a 905G “sees” a large number of changes in its database at the one time. For example, if a host writes a block of 100 signal values to a 905G, and 20 of these values have changed since the last write-operation. If the block is mapped to another 905G, then the 905G can transmit all 20 values in one radio message, instead of 20 messages.

Normal I/O messages can be repeated by any type of 905U I/O module, however block read/write messages can only be repeated by other 905G modules.

Block Read Message

A block read message is a request to another 905G to transmit the values of a consecutive block of registers. The destination 905G will respond with the values, which will be stored in a corresponding block of registers in the originating 905G. A block read message can be triggered by:

- ◆ time period, configurable 1 – 4096 sec (1.1 hour), or
- ◆ real time clock, or
- ◆ on demand by the host device, by writing to a “trigger register” in the 905G.

Block Write Message

A block write message transmits a consecutive block of register values from one 905G to a destination 905G. It can be triggered by:

- ◆ time period, configurable 1 – 4096 sec (1.1 hour), or
- ◆ real time clock, or
- ◆ on demand by the host device, by writing to a “trigger register” in the 905G, or
- ◆ a change-of-state event occurring within the block of I/O registers.

If a block write message has been configured to be transmitted on change-of-state, a “time window” is configured. When a change-of-state occurs in one of the registers in the block, the time window will be activated. All changes during the time window will be grouped together and transmitted as one block write message. That is, the block write message will not be sent immediately the first change-of-state occurs (unless the time window is configured to zero), but will be sent at the end of the time window - any other registers in the block that change during the time window will be sent as part of the same message. The time window can be configured from 0 – 255 seconds.

1.3.3 “Data Concentrator” Networks

905G units can act as “data concentrator” units to collect I/O from a local network of 905U wireless I/O modules and pass the I/O on to another 905G as a block.

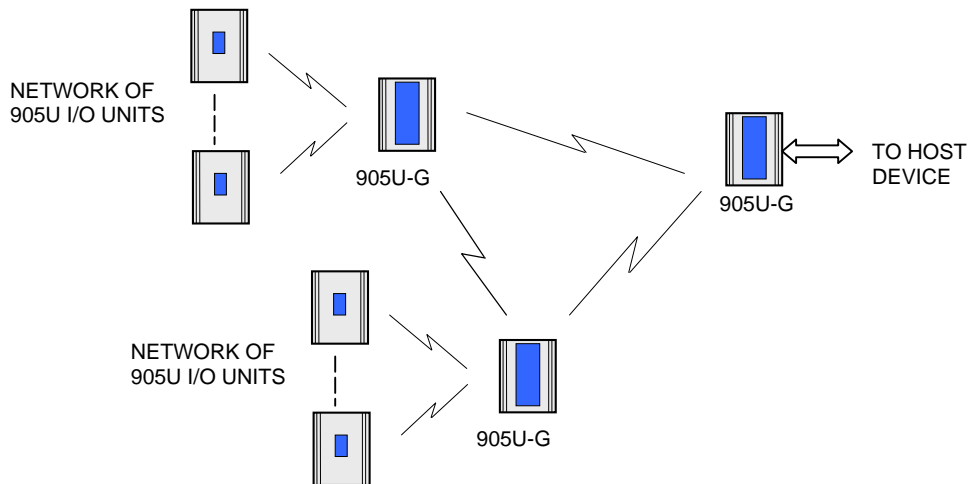

This type of network reduces the amount of radio traffic and is suitable for systems with a large number of I/O modules. The system is divided into local sub-networks, each with a 905G unit. The 905U modules transmit their I/O values to the 905G. The 905G then transfers these values to the “central” 905G using a block transfer which is very efficient compared to a lot of individual I/O transmissions.

The data concentrator network is different than using the 905G as a repeater. A repeater re-transmits each message in the same format. A data concentrator collects the I/O values as a block, and transmits the complete block in one transmission.

1.3.4 905G Repeaters

Any 905U module can repeat a normal radio message, however only 905G modules can repeat a block message. 905G units connected to a host device can also act as a repeater for other modules.

Where a 905G is being used without a host device as a repeater or data-concentrator, it can be configured as “Repeater-only”. This allows the RS232/485 port to be used for on-line diagnostics. If the unit is a 905U-G-MD1, the “Repeater-only” configuration also allows this module to connect to 105S serial I/O modules.

Chapter 2

OPERATION

2.1 Start-up

The 905G operating software and the database configuration are stored in non-volatile memory, however the database I/O register values are lost on power failure (in the same way as a PLC).

On start-up, the 905G sends "start-up poll" messages to remote modules based on the source address of inputs configured in the database (the start-up messages can be disabled by configuration). The remote modules respond with update messages for their inputs, which sets initial values in the 905G I/O database registers. The 905G provides a delay of 5 seconds between each start-up poll, to allow the remote module to respond and to avoid overloading the radio channel.

If there are a lot of remote modules, then this start-up stage may take a significant time, and this should be allowed for in the system design. The 905G has an internal battery charger feature and the use of a back-up battery should be considered if this start-up delay presents a constraint to system reliability. Start-up polls may be disabled for individual remote modules in the database configuration.

For the host device, the 905G provides an "Active" signal on the RS232 port (DCD pin 1). Its purpose is to indicate to the host that the 905G is now processing output messages for the remote modules. When the 905G powers down (or should an internal fault occur), the "Active" signal resets (turn "off" or "0"). When the 905G starts-up, it holds the "Active" signal in a reset condition ("off" or "0") for a time equal to the number of remote addresses (or modules) configured times 5 seconds plus any delay if remote addresses are offline. For example, if there are 20 remote addresses configured in the 905G database, then the "active" signal will be held in the reset state for 100 seconds (20 x 5). During this period, the 905G will not change any output values in its database. After this time, the 905G will set the "Active" signal (to "on" or "1") - the host can then send messages to the 905G to update the output values in the database.

2.2 Operation

The 905G database can hold values for 4300 I/O signals plus the 8 on-board I/O. The database registers (also called I/O registers) can be accessed by both the radio port and the fieldbus port. The host device can change values in the database via the fieldbus, and the 905G can transmit radio messages out with the new values. Radio messages can be received with new values for database registers, and these new values can be written to the host device or read by the host device, via the fieldbus.

The 905G operation must be configured before the 905G will function. Configuration is achieved by creating a configuration file on a PC and downloading this file to the 905G. The 905G configuration may also be "uploaded" to a PC for viewing and modification. For more information, refer to the **Configuration** section of this document.

Each I/O register in the 905G database has a 16-bit value. It doesn't matter if the remote I/O is digital (discrete), analog or pulse. The host protocol driver in the 905G will convert the 16 bit value into a value that the host will understand. For example, if the host device requests a

binary/digital read command, the 905G will convert the 16 bit value into a binary (1 bit) value before it responds.

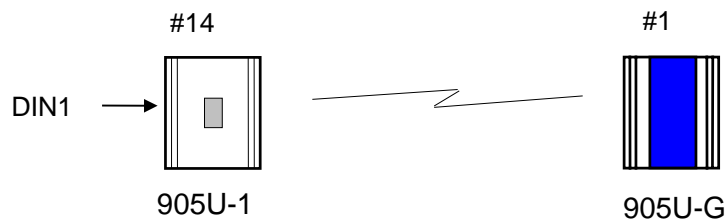

An example of normal operation - assume that a remote module has address 14 and the 905G is address 1. Module #14 is configured with a mapping DI1 → I/O Reg 76 at #1. When DI1 turns "on", module #14 transmits a message. If the 905G can hear this message, it will transmit an acknowledgment back to module #14, and updates the value of I/O register 76 in the 905G database. The host device can read I/O register 76 via the data-bus, or the 905G may write the value of I/O register 76 to the host device.

I/O registers that receive values from other 905U or G modules via radio are configured with a "Communications fail time". If the 905G does not receive a message for this I/O register within the comms-fail time, then the I/O register is given a "comms fail" status which the host device can read.

I/O registers that transmit out to other 905U or G modules are configured with an "update time" and a "sensitivity". The 905G will transmit a message to the configured remote output whenever the I/O register value changes by the sensitivity amount – if it has not changed within the update time, the 905G will send a message anyway. The 905G will make five attempts to send a message - if it does not receive an acknowledgment from the remote module, then the I/O register is given a "comms fail" status which the host device can read.

Each I/O register has an associated "status" register, which includes information such as comms-fail status. As well as each I/O register having an individual comms-fail status, each remote module has an overall comms fail status. This status is "set" (on) whenever a comms-fail occurs for an individual I/O register, and is "reset" (off) whenever a message is received from the remote module. The 905G can be configured to not send any update messages to a remote module if it senses that the remote module is in "comms fail" - that is, if any I/O register associated with the remote module is in "comms fail". It will start sending update messages again when the 905G receives a message from the remote module. The default configuration is that output updates ARE sent during comms fail conditions.

2.3 Database

The 905G database (Radio Interface) has 10 000 registers, each of 16 bit size. The structure of the database is:

Registers	Purpose
0 - 4299	I/O registers
4300 - 4399	On-board I/O
4401 - 4499	Comms-fail status and radio strengths for remote modules
5000 - 9499	Status registers - 16 bit status for each I/O signal
9500 - 9999	Status registers for block read/write messages

The register numbers may be used by the Host Protocol Driver to access I/O values and I/O status information. Each configured I/O point has a 16 bit value (in registers 0000 - 4299), and a 16 bit status value. The status register is located at 5000 plus the I/O value register. For example, an I/O point in register number 2560 has a status value in register number 7560 (5000 + 2560).

Details of the status register are provided in Appendix A. The most important part of the status register is the 15th or most significant bit - this indicates comm-fail status for the I/O register. If the most significant bit is set, then the I/O register is in comms-fail.

The host device can read the status registers. For example, the communications status of an output configured at register number 3001 can be examined by reading register number 8001 (5000 + 3001). If the register value is greater than 32767, then the 15th bit is set, indicating that the output has a communications failure.

2.3.1 On-board I/O and Internal I/O

The 905G has eight discrete I/O points. These may be used as inputs or as outputs. Inputs are linked to registers 4300-4307. That is, if a contact connected to DIO1 is “on”, then register 4300 is given an “on” value. Outputs are controlled from registers 4320-4327; that is, if register 4327 is set to an “on” value, then output DIO8 is activated.

Whenever an output register is set “on”, the corresponding input register is automatically set “off”. For example, if register 4321 is set to “1”, the 905G will also set 4301 to “0”. This means that if both the input and output registers corresponding to the same I/O point are used in the configuration, then the output register has priority.

Outputs may be written to by either the host device or by a remote 905U via the radio port. Input values can be sent to the host device or to a remote module via the radio port.

The 905G also monitors its battery voltage and supply voltage. These are stored in registers 4310 and 4311 respectively, as 16 bit values, scaled so that a value of 16384 decimal (hex 4000) corresponds to 8 V, and a value of 49152 (hex C000) corresponds to 40V.

A low battery alarm is available at register 4308. This becomes active when the battery voltage falls below 11.3V, and clears when the battery voltage rises above 11.8V. Supply

voltage is also monitored, and an alarm is available at register 4309. This becomes active if the supply voltage falls below 8.0V, and clears when the supply voltage rises above 9.0V.

I/O Register	Description	I/O Register	Description
4300	Input value DIO 1	4320	Output value DIO 1
4301	Input value DIO 2	4321	Output value DIO 2
4302	Input value DIO 3	4322	Output value DIO 3
4303	Input value DIO 4	4323	Output value DIO 4
4304	Input value DIO 5	4324	Output value DIO 5
4305	Input value DIO 6	4325	Output value DIO 6
4306	Input value DIO 7	4326	Output value DIO 7
4307	Input value DIO 8	4327	Output value DIO 8
4308	Low battery voltage status		
4309	Supply voltage fail status		
4310	Battery voltage value		
4311	Supply voltage value		

2.4 The Host - 905G Link

For the host device, the 905G "looks" like a single device (or a "virtual PLC"), containing the I/O for the complete wireless I/O system.

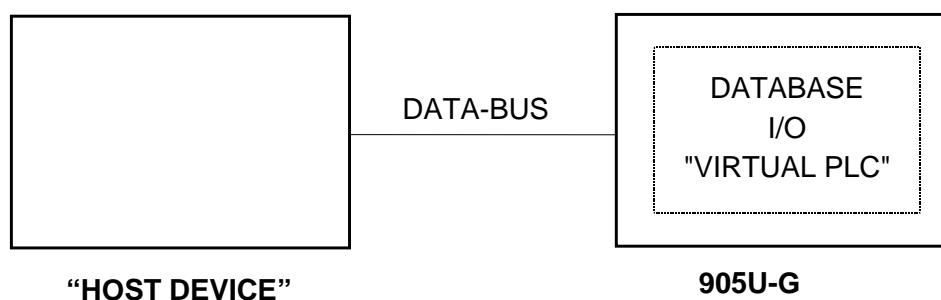

2.4.1 Modbus / DF1

The user selects whether the 905U-G-MD1 should act as a Modbus Master or Modbus Slave or DF1 device.

The data type and baud rate of the serial communications must be configured at the 905G to match the host. Data types can be 7 or 8 bit, even/odd/no parity, with 1 or 2 stop bits. Data rates can be 300 - 19200 baud.

The full 905G database (4300 registers) can be accessed by the Host Device.

2.4.2 Profibus

The Profibus port has auto-detect of baud rate from 9600 bits/sec to 12Mbit/sec - no configuration is required.

The Profibus units have internal hardware comprising the Profibus Interface. The Profibus Interface handles all Profibus DP Network communications. The internal Radio Interface is separate to the Profibus Interface, and handles all radio communications. I/O in the Radio Interface is linked to I/O in the Profibus Interface in a flexible way via ESeries Configuration Software.

The Profibus Slave interface provides a total of 416 I/O bytes, with a maximum 244 input bytes and maximum 244 output bytes. A Profibus byte can contain 8 discrete (binary) values, or two bytes can be used for a 16-bit analogue or pulse register. So the Profibus interface is limited to 1952 discrete inputs or 122 analogue inputs or a combination. The same applies for outputs.

For example, a Profibus host wants to read 800 discrete inputs (100 bytes) and write 400 discrete outputs (50 bytes). This will take up 150 bytes of the Profibus Interface, leaving 266 left. The remaining bytes could be used for 133 analogue I/O - up to 72 analogue inputs (244 – 100 discrete input bytes) plus 61 analogue outputs - or vice-versa.

The Profibus Master interface provides a total of 2048 input bytes and 2048 output bytes. A byte can contain 8 discrete (binary) values, or two bytes can be used for a 16-bit analogue or pulse register. So the interface is limited to 4300 discrete inputs (the limit of the 905G database) or 1024 analogue inputs (the limit of the HMS interface) or a combination. The same applies for outputs.

2.4.3 Ethernet

The Ethernet port automatically handles Ethernet communications at 10 or 100 Mbit/sec. An IP address is entered so that other Ethernet devices can recognize the 905G.

The Ethernet units have internal hardware comprising the Ethernet Interface. The Ethernet Interface handles all Ethernet Network communications. The internal Radio Interface is separate to the Ethernet Interface, and handles all radio communications. I/O in the Radio Interface is linked to I/O in the Ethernet Interface in a flexible way via ESeries Configuration Software.

The Ethernet Interface provides a total of 2048 input bytes and 2048 output bytes. An Ethernet byte can contain 8 discrete (binary) values, or two bytes can be used for a 16-bit analog or pulse register. So the Ethernet Interface is limited to 4300 discrete inputs (the limit of the 905G database) or 1024 analog inputs (the limit of the Ethernet interface) or a combination. The same applies for outputs.

For example, an Ethernet host wants to read 500 analog inputs (1000 bytes). The remaining input bytes (1548) could be used for 12,384 discrete inputs - but the 905G database is not this big. Provided there are no outputs required, there could be 3800 discrete inputs (4300 – 500 analogs). If there are outputs required, then the number of discrete inputs available will be further limited.

2.5 Radio System Design

Each wireless I/O system can have up to 95 unit addresses, although up to 255 905K module can share the same unit address (refer to 905K User Manual).

Each 905U module can have up to 31 x 105S modules connected to it. These modules are addressed 96 - 127. More than one 105S module can have the same address, provided they are not connected to the same 905U module - that is, #100 via #16 is identified as a different module to #100 via #65.

A constraint that needs to be considered is the capacity of the radio channel. If there is too much traffic on the radio channel, then the system quickly becomes unreliable. The recommended maximum average traffic density is 100 messages per minute provided all radio paths are reliable. If there are marginal radio paths, resulting in re-tries of transmitted messages, then the maximum traffic density is reduced considerably. Each block read/write messages should be counted as two messages because of the length of these messages.

A 905G can be used as a repeater module for messages between other modules.

2.5.1 Radio Signal Strength

The 905G records the radio signal strength of remote modules that communicate directly (that is, not via repeaters). There are 95 database registers (4401 – 4495) which store the radio strengths – corresponding to remote addresses #1 - #95. The radio strength (RSSI) is measured in dBm (relative to 1mW of RF power). The RSSI value is stored in the 8 least significant bits of each register - a value of –84 dBm would be stored as decimal 84.

These database registers will hold the strength of the last message received from the address. If a message is received from a remote module via a repeater, then the measurement is recorded in the address of the last repeater. For example, if a message is received from #24 directly, then the RSSI will be recorded in register 4424. If a message is received from #24 via #25, then the RSSI is recorded in register 4425. The 905G will not know what the radio strength of the message from #24 to #25 is. If #25 is another 905G, then it can record this RSSI and this register could be mapped to an I/O register in the first 905G.

The RSSI registers can be read by the host device, or mapped to I/O registers in other 905G modules.

The first half of the register (8 most significant bits) will be decimal 0 (hex 00) if the remote module has active communications. If a comms fail status to this address occurs, the most significant bit will be set. For example, if the last message received from #38 is –99dBm, then the 16 bit value of register 4438 will be decimal 99 or hex 0063. If the “comms fail” status for #38 is set, the 16 bit value of register 4438 will become decimal 32,867 (32768 + 99) or hex 8063.

2.5.2 Repeaters

Radio paths may be extended by using intermediate modules as repeaters. A repeater will receive and re-transmit the radio message. Up to five repeater addresses can be configured - that is, a radio message can pass through five intermediate modules. For normal I/O messages, any 905U module (except 905U-K modules) can be used as a repeater, however for block read/write messages, only 905G modules can act as repeaters.

2.6 Radio Comms Failure

The 905G has an internal "communications failure" (comms fail) status for each I/O point in its database. There is also a comms fail status for each module with direct communications - see 2.5.1 above.

For I/O registers which are mapped to a remote output or another 905G, the comms fail status is set if the 905G does not receive an acknowledgment for a message being sent to that remote output. The comms fail status resets when a successful transmission occurs.

For I/O registers which have been mapped, from a remote input or another 905G, a comms fail time period may be configured. If a radio message for this I/O register has not been received within this time, then this registers comms fail status is set. The comms fail status will reset when a message is received for this register. If the comms fail time is configured as zero, then the comms fail status will never be activated.

The communications failure status is bit 15 of the status register for each I/O point. If the host device reads a register as a digital or binary value, then the 905G returns bit 15 of the register (0 or 1) - this is the comms fail bit of a status register.

It is important to use the comms fail status in the overall system design, as any system can fail.

The 905G also provides an additional comms failure feature to stop the 905G transmitting output messages to an individual remote address if the 905G already knows that this remote address is in communication failure. This prevents the 905G from congesting the radio channel with a lot of unnecessary transmissions (and re-transmissions). This function is called "Don't Send if In Comm Fail" and is configurable by the user for each individual remote address. The 905G retains a "remote address comms fail" status for the remote addresses configured for this function. If any output with this remote address goes into communications failure, then the remote address comms fail status is set ("on" or 1) - every time an input with this remote address receives a radio message, then the remote address comms fail status is reset ("off" or 0). While the remote address comms fail status is set, the 905G disables any output messages being sent to this remote address.

When this feature is configured, all output transmissions are stopped if communications with a remote module fails for a short period. They will start again when an input message from this module is received. If the 905G determines that a output message should be sent to an output which is disabled because of this feature, then the output message will not be sent and the comms fail status of that output is set ("on" or 1).

If it is desired to use this function with a remote 905U module, but there are no inputs from this module being used, then it is easy to configure an unused input or an internal input (mains fail or low battery voltage etc). It is the comms fail status for the input, which is used, not the input itself.

2.6.1 Monitoring Communications Failure

The host device can monitor the communications status of an I/O point by reading the status register for this point as a binary/discrete register. Modbus, and many other protocols, will convert a 16 bit register value to a binary/discrete value by returning the most significant bit - for the status register, this corresponds to the comms status bit.

For example, to monitor the comms status of I/O register 1045, perform a binary/discrete read on register 6045 (the status register for 1045). A value of "1" will be returned if this I/O point is in comms fail, and a "0" returned if the status is normal.

If it is desired to monitor the comms status of all I/O points, it is more efficient to only monitor the comms status of one I/O point at each remote module (if this point is in comms fail, then all points at the remote module will be in comms fail). If this point is an input, then the comms fail time for this input can be made short, to give an early warning of a

comms problem (this means that the corresponding update time for the input at the 905U will need to be short). If the point is an output, then the update time for the output should be made short.

2.7 Security Considerations

There are three dimensions of security considerations:

1. Failure to operate when required - or “operational reliability”.

The features discussed above optimize operating reliability. Using an acknowledgment and re-try protocol ensures that the transmitting module is aware whether the transmitted message has been transmitted reliably. The “comms fail” alarms provide indication if the radio link has failed to operate.

2. Mal-operation, or operating when not requested.

This problem occurs when an output is “triggered” by the wrong radio device. The 905G modules use frequency encoding and a very secure addressing system to ensure this does not occur. An additional security level using data encryption can also be selected.

3. Malicious operation, or “hacking”

This is the problem most associated with security concerns - the ability for someone to access information from a radio system by “listening-in”, or to cause damage by transmitting radio messages to force outputs.

A security option can be selected during the module configuration to protect against this. The security option (if selected) adds data encryption to radio messages. Modules in the same system are automatically configured with the encryption key, such that only these modules can understand each other. “Foreign” modules will hear the messages, but cannot decrypt the messages. For more information, refer to section 4.2.2.

Chapter 3

INSTALLATION

3.1 General

The 905G module is housed in a rugged aluminum case, suitable for DIN-rail mounting. Terminals will accept wires up to 12 gauge (2.5 sqmm) in size.

All connections to the module must be low voltage (SELV). Normal 110-240V mains supply should not be connected to any terminal of the 905G module. Refer to Section 3.3 Power Supply.

Before installing a new system, it is preferable to bench test the complete system. Configuration problems are easier to recognize when the system units are adjacent. Following installation, the most common problem is poor communications caused by incorrectly installed aerials, or radio interference on the same channel, or the radio path being inadequate. If the radio path is a problem (i.e. path too long, or obstructions in the way), then higher performance aerials or a higher mounting point for the aerial may rectify the problem. Alternately, use an intermediate 905U Module as a repeater.

The foldout sheet 905U-G *Installation Guide* provides an installation drawing appropriate to most applications. Further information is detailed below.

Each 905G module should be effectively earthed/grounded via the "GND" terminal on the 905U module - this is to ensure that the surge protection circuits inside the module are effective.

3.2 Antenna Installation

The 905G and 905U modules will operate reliably over large distances. The distance which may be reliably achieved will vary with each application - depending on the type and location of antennas, the degree of radio interference, and obstructions (such as hills or trees) to the radio path. Typical reliable distances are :

USA/Canada	15 miles	6dB net gain antenna configuration permitted (4W ERP)
Australia/NZ	12 km	unity gain antenna configuration (1W ERP)

Longer distances can be achieved if one antenna is mounted on top of a hill.

To achieve the maximum transmission distance, the antennas should be raised above intermediate obstructions so the radio path is true "line of sight". Because of the curvature of the earth, the antennas will need to be elevated at least 15 feet (5 metres) above ground for paths greater than 3 miles (5 km). The modules will operate reliably with some obstruction of the radio path, although the reliable distance will be reduced. Obstructions that are close to either antenna will have more of a blocking effect than obstructions in the middle of the radio path. For example, a group of trees around the antenna is a larger obstruction than a group of trees further away from the antenna. The 905G modules provide a test feature that displays the radio signal strength.

Line-of-sight paths are only necessary to obtain the maximum range. Obstructions will reduce the range, however may not prevent a reliable path. A larger amount of obstruction can be tolerated for shorter distances. For very short distances, it is possible to mount the

antennas inside buildings. An obstructed path requires testing to determine if the path will be reliable - refer the section 6 of this manual.

Where it is not possible to achieve reliable communications between two modules, then another 905U or 905G module may be used to receive the message and re-transmit it. This module is referred to as a repeater.

An antenna should be connected to the module via 50 ohm coaxial cable (eg RG58, RG213 or Cellfoil) terminated with a male SMA coaxial connector. The higher the antenna is mounted, the greater the transmission range will be, however as the length of coaxial cable increases so do cable losses. For use on unlicensed frequency channels, there are several types of antennas suitable for use. It is important antenna are chosen carefully to avoid contravening the maximum power limit on the unlicensed channel - if in doubt refer to an authorized service provider.

The net gain of an antenna/cable configuration is the gain of the antenna (in dBi) less the loss in the coaxial cable (in dB).

The maximum net gain of the antenna/cable configuration permitted is

Country	Max. gain (dB)
USA / Canada	6
Australia / New Zealand	0

The gains and losses of typical antennas are

Antenna	Gain (dB)	Elpro Part Nos.
Dipole with integral 15' cable	0	CFD890EL
5dBi Collinear (3dBd)	5	SG900EL
8dBi Collinear (6dBd)	8	SG900-6
6 element Yagi	10	YU6/900
9 element Yagi	12	
16 element Yagi	15	YU16/900
Cable type	Loss (dB per 30 ft / 10 m)	
RG58	-5	
RG213	-2.5	
Cellfoil	-3	CC10/900 (33' or 10m) CC20/900 (66' or 20m)

The net gain of the antenna/cable configuration is determined by adding the antenna gain and the cable loss. For example, a 6 element Yagi with 66 feet (20 meters) of Cellfoil has a net gain of 4dB (10dB – 6dB).

Connections between the antenna and coaxial cable should be carefully taped to prevent ingress of moisture. Moisture ingress in the coaxial cable is a common cause for problems with radio systems, as it greatly increases the radio losses. We recommend that the connection be taped, firstly with a layer of PVC Tape, then with a vulcanizing tape such as “3M 23 tape”, and finally with another layer of PVC UV Stabilized insulating tape. The first layer of tape allows the joint to be easily inspected when trouble shooting as the vulcanizing seal can be easily removed.

Where antennas are mounted on elevated masts, the masts should be effectively earthed to avoid lightning surges. For high lightning risk areas, surge suppression devices between the module and the antenna are recommended. If the antenna is not already shielded from lightning strike by an adjacent earthed structure, a lightning rod should be installed above the antenna to provide shielding.

3.2.1 Dipole and Collinear antennas.

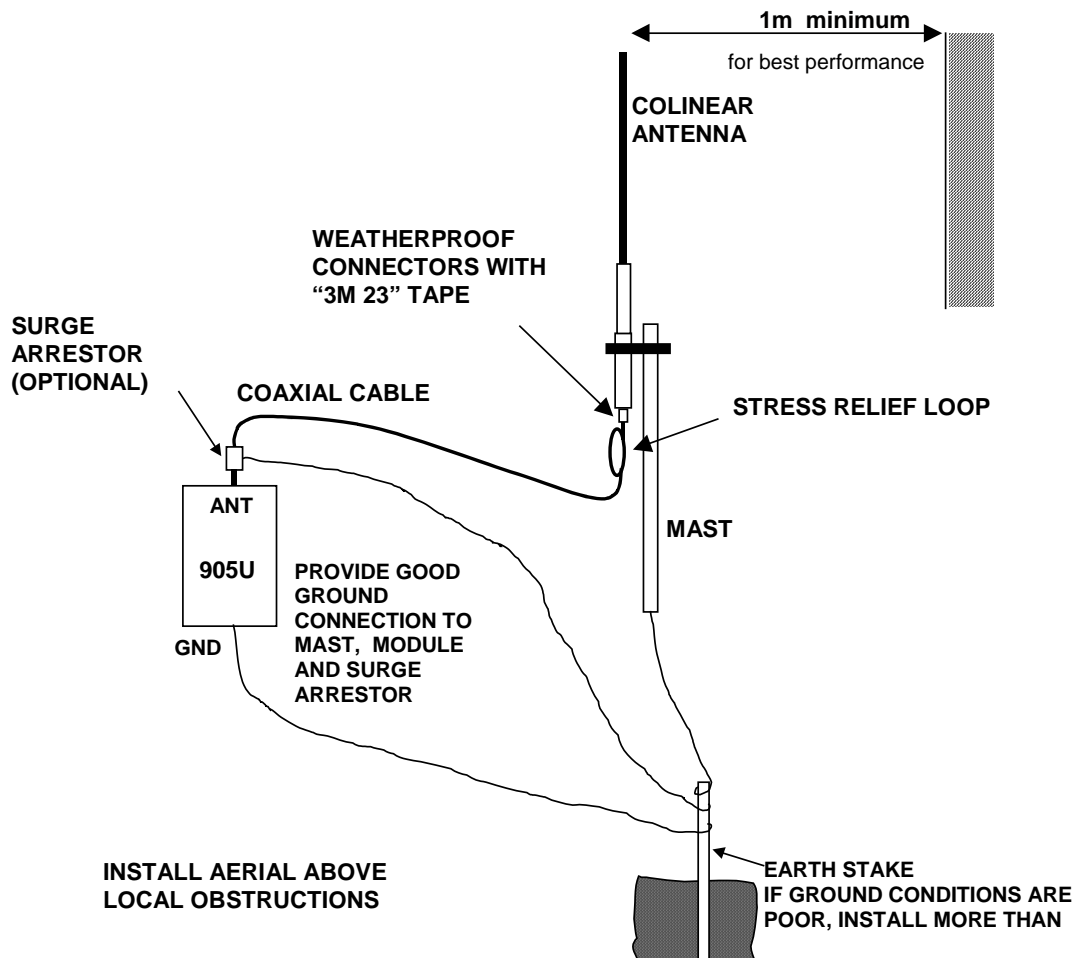

A collinear antenna transmits the same amount of radio power in all directions - it is easy to install and use. The dipole antenna with integral 15 ft (5m) cable does not require any additional coaxial cable, however the other collinear antennas do not have integral cable and an external cable length must be connected - such as the CC10 or CC20 cable kits..

Collinear and dipole antennas should be mounted vertically, preferably no less than 2 ft (0.6 metre) away from a wall or mast to obtain maximum range. The CFD890 dipole antenna is the preferred antenna for use in industrial plants and factories.

3.2.2 Yagi antennas.

A Yagi antenna provides high gain in the forward direction, but lower gain in other directions. This may be used to compensate for coaxial cable loss for installations with marginal radio path.

The Yagi gain also acts on the receiver, so adding Yagi antennas at both ends of a link provides a double improvement.

Yagi antennas are directional. That is, they have positive gain to the front of the antenna, but negative gain in other directions. Hence Yagi antennas should be installed with the central beam horizontal and must be pointed exactly in the direction of transmission to benefit from the gain of the antenna. The Yagi antennas may be installed with the elements in a vertical plane (vertically polarized) or in a horizontal plane (horizontally polarized). For a two station installation, with both modules using Yagi antennas, horizontal polarization is recommended.

If there are more than two stations transmitting to a common station, then the Yagi antennas should have vertical polarization, and the common (or “central” station should have a collinear (non-directional) antenna.

Also note that Yagi antennas normally have a drain hole on the folded element - the drain hole should be located on the bottom of the installed antenna.

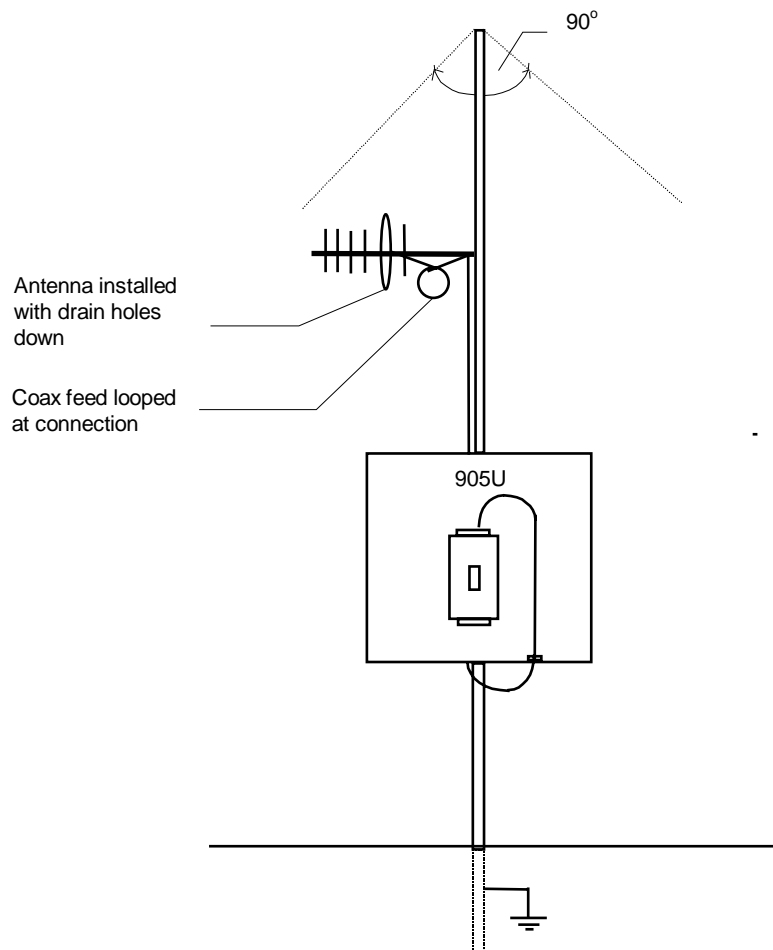

3.3 Power Supply

The 105G power supply is a switch-mode design which will accept either AC or DC supply. The module includes an integral battery charger for a backup battery.

The module accepts supply voltages in the following ranges :

12 – 24 volts AC RMS or 9 – 30 volts DC at the “supply” terminals, or

10.8 – 15 volts DC at the “battery” terminals.

The power supply should be rated at 1.5 Amps and be CSA Certified Class 2. For use in Class 1 Div 2 explosive areas (USA/Canada), the power supply must be approved for Class 1 Div 2 use.

3.3.1 AC Supply

The AC supply is connected to the “SUP1” and “SUP2” terminals as shown below. The AC supply should be “floating” relative to earth.

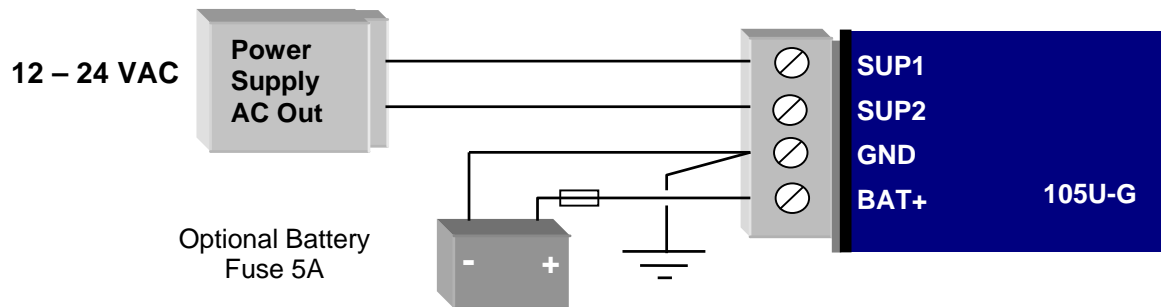

3.3.2 DC Supply

For DC supplies, the positive lead is connected to “SUP1” and the negative to “GND”. The positive side of the supply **must not be connected to earth.** The DC supply may be a floating supply or negatively grounded.

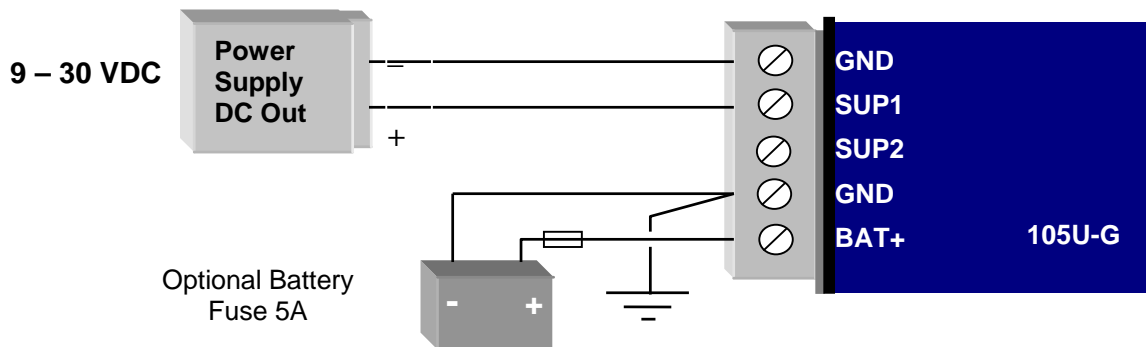

The module may also be powered from an external 11 – 15 VDC battery supply without the need for a “normal” supply connected to “SUP1”. This external battery supply is connected to “BAT+” and “GND” terminals. The positive lead of the external supply should be

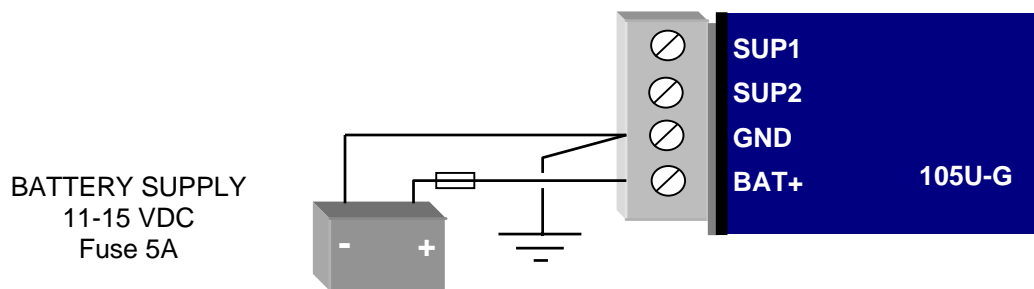

protected by a 5A fuse.

Upon failure of the normal supply, the module may continue to operate for several hours from a backup battery. The battery charger is designed for sealed or vented lead acid batteries between 5 and 24 amp hours - **other types of batteries should not be used.** Typically, a 5 Ahr battery will supply the 105G for 1 – 2 days, depending on the type of 105G.

On return of normal supply, the unit will recharge the battery. The maximum output of the battery charger is 0.7A when the supply voltage is greater than 12V, and 0.3A for less than 12V.

The 105G monitors the power supply and provides the following internal values, which can be mapped as I/O values:

- Power failure (I/O Reg 4309) - if the supply voltage drops below 8V, this status value is set on, and set off again when the voltage is more than 9V. For AC Supplies, this indicates low voltage at approximately 10 VAC, and the status is cleared when the supply voltage rises above approximately 12VAC
- Low battery voltage (I/O Reg 4308) - this status value is set on if the battery voltage drops to 11.3, and resets off when the battery voltage is more than 11.8V.
- Battery voltage value (I/O Reg 4310) - 8 – 40VDC corresponds to hex 4000 – hex C000.
- Supply voltage (I/O Reg 4311) - 8 – 40VDC corresponds to hex 4000 – hex C000.

3.3.3 Solar Supply

A 105G can be powered from a solar supply using an external regulator. If a 12V solar supply is used, the 12V battery can be connected to the battery supply connections of the 105G and the 105G will monitor for low battery status and also battery voltage. If a 24V solar supply is used, the 24V battery should be connected as a DC supply (SUP1 and GND) - the supply voltage can be monitored however the “supply fail” voltage will activate too low to be used as a battery fail status.

3.4 Input / Output

The 105G has eight on-board discrete/digital I/O. These act as both discrete inputs and discrete outputs.

3.4.1 Digital Inputs / Outputs

All eight of the 105G DIO terminals may be used as discrete inputs. These inputs are suitable for voltage free contacts (such as mechanical switches) or NPN transistor devices

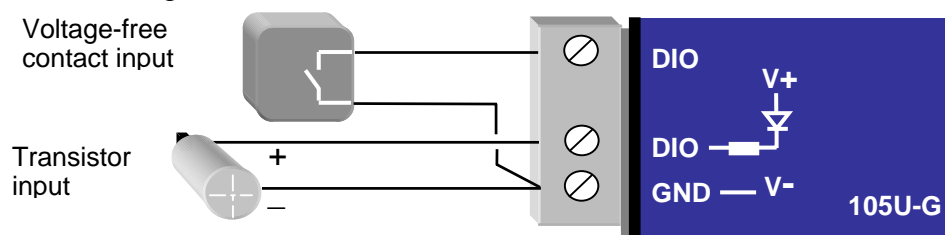

(such as electronic proximity switches). PNP transistor devices are not suitable. Contact wetting current of approximately 5mA is provided to maintain reliable operation of driving relays.

Each digital input is connected between the appropriate “DIO” terminal and common “COM”. Each digital input circuit includes a LED indicator which is lit when the digital input is active, that is, when the input circuit is closed. Provided the resistance of the switching device is less than 200 ohms, the device will be able to activate the digital input.

All eight of the 105G DIO terminals may also be used as discrete outputs. The digital outputs are transistor switched DC signals, FET output to common rated at 30VDC 500 mA.

Digital outputs may be configured to individually turn off if no command message is received to that output for a certain period. This feature provides an intelligent watch dog for each output, so that a communications failure at a transmitting site causes the output to revert to a known state. See Chapter 4 **Configuration** for further details.

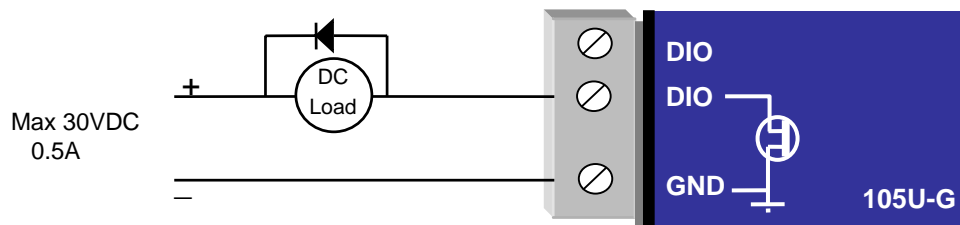

The output circuit is connected to the appropriate “DIO” terminal. Each digital output circuit includes a LED indicator which is lit when the digital output is active.

3.5 Serial Port

3.5.1 RS232 Serial Port

The serial port is a 9 pin DB9 female and provides for connection to a terminal or to a PC for configuration, field testing and for factory testing. It is also used by the Modbus/DF1 version for fieldbus connection.

This port is internally shared with the RS485 - ensure that the RS485 is disconnected before attempting to use the RS232 port. Communication is via standard RS232 signals. The 905G is configured as DCE equipment with the pinout detailed below.

DB9 Connector Pinout:

Pin	Name	Direction	Function
1	DCD	Out	Used for "active" signal.
2	RD	Out	Serial Data Output
3	TD	In	Serial Data Input
4	DTR	In	Data Terminal Ready - may be used by Host Protocol Driver
5	SG		Signal Ground
6	DSR	Out	Data Set Ready - always high when unit is powered on.
7	RTS	In	Request to Send - may be used by Host Protocol Driver
8	CTS	Out	Clear to send - may be used by Host Protocol Driver
9	RI		Ring indicate - not connected

Hardware handshaking using the CTS/RTS lines is provided, and are under the control of the Host Comms Driver. Example cable drawings for connection to a DTE host (a PC) or another DCE host are detailed below:

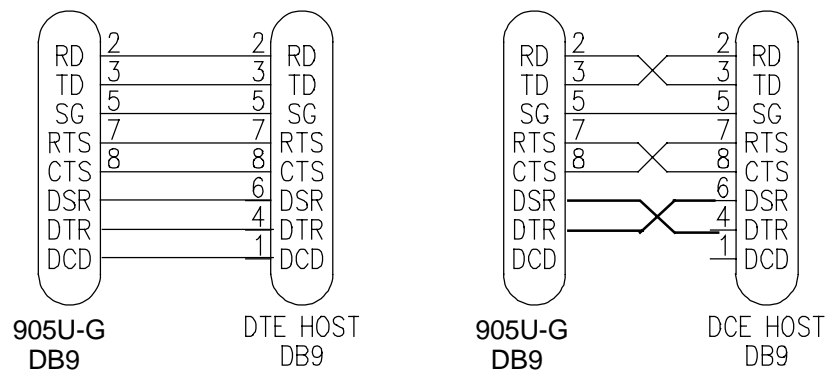

3.5.2 RS485 Serial Port

RS485 should not be used with the DF1 unit. The RS485 port provides for communication between the 905G unit and its host device using a multi-drop cable. Up to 32 devices may be connected in each multi-drop network. Note that the RS485 port is shared internally with the RS232 port - make sure that the RS232 port is disconnected before using the RS485 port.

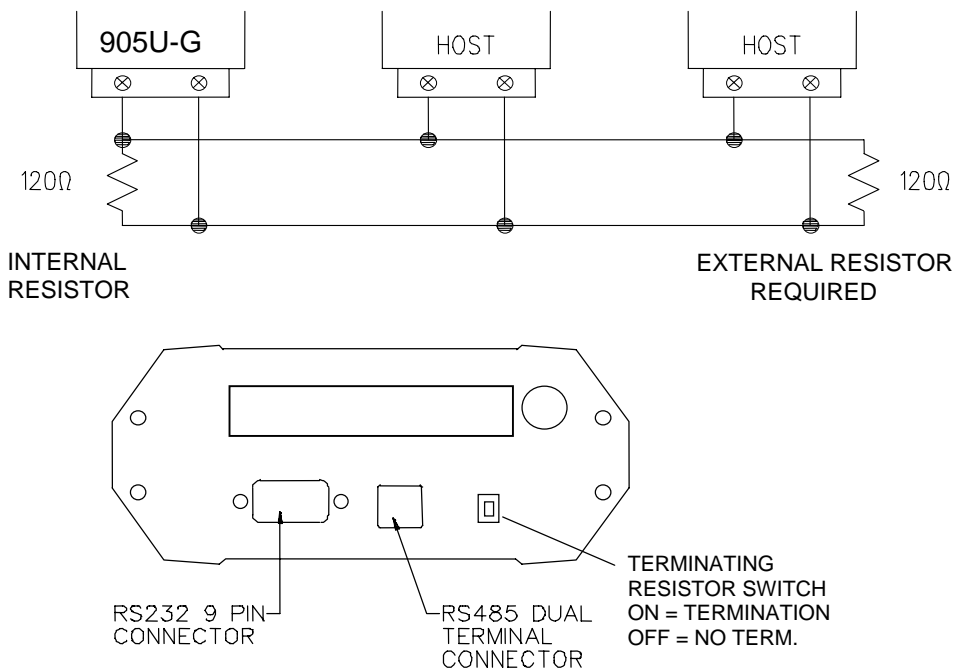

RS485 is a balanced, differential standard but it is recommended that shielded, twisted pair cable be used to interconnect modules to reduce potential RFI. An RS485 network should be wired as indicated in the diagram below and terminated at each end of the network with a 120-ohm resistor. On-board 120 ohm resistors are provided and may be engaged by operating the single DIP switch in the end plate next to the RS485 terminals. The DIP switch should be in the “1” or “on” position to connect the resistor. If the module is not at one end of the RS485 cable, the switch should be off.

It is important to maintain the polarity of the two RS485 wires. On the 905G, terminal A (the terminal on the right) is positive and terminal B is negative.

3.6 Profibus Port

The Profibus RS485 connector is a D9 connector in the top end-plate of the module (see below).

905U-G-PR1 (Profibus Slave) End Plate:

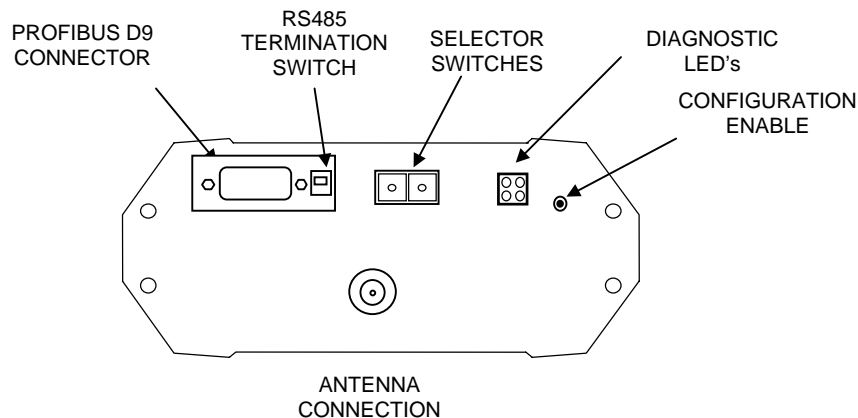

Note: If the “Use Rotary Switch Address” option in configuration software is selected, the two rotary switches are used to specify the Profibus Node Address in the range 0 – 99. In this case, the value on the left switch is multiplied by 10 and added to the value on the right switch to give the node address.

Where the 905G module is mounted at the end of the RS485 link, the RS485 link should be terminated by switching the termination switch “on” (down in the above diagram).

905U-G-PR2 (Profibus Master) End Plate:

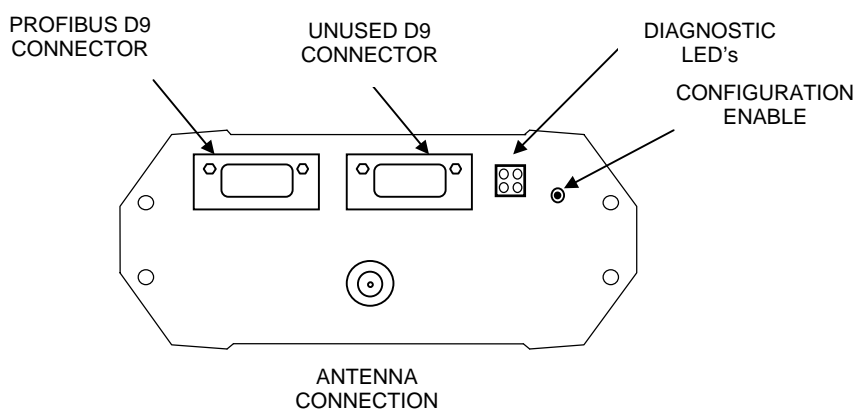

For the Profibus Master 905G a second, unused, connector is also present.

The Profibus RS485 connection should be made to pins 3 and 8 of the Profibus D9 connector. The pinouts for this connector are:

Pin	Description
1	Not connected
2	Not connected
3	+ve RS485 (Positive)
4	RTS (request to send)
5	GND - Isolated GND from RS485 side
6	+5V - Isolated 5V from RS485 side
7	Not connected
8	-ve RS485 (Negative)
9	Not connected

3.7 Ethernet Port

For 905U-G-ET1 modules only.

The Ethernet connection uses a standard RJ45 connector on the top end-plate of the module. The selector switches should all be “off” (in the diagram below, “off” is up).

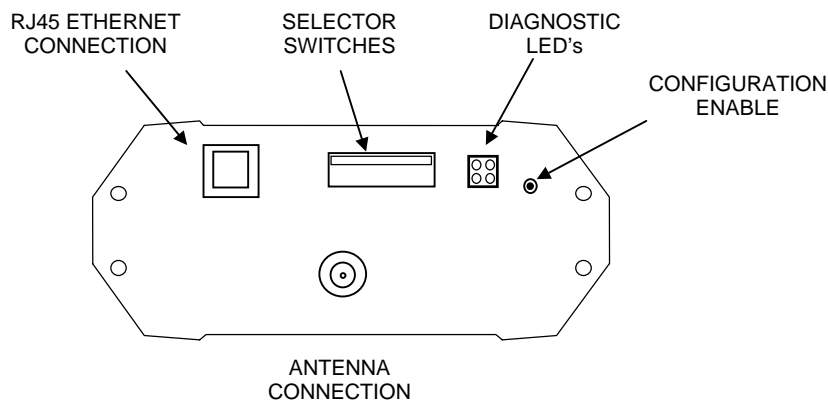

3.8 Modbus Plus Port

For 905U-G-M+1 modules only.

Connection to the Modbus Plus Network is via the 9-pin D-SUB connector located at the antenna end of the module. Pin-outs are outlined in the table below.

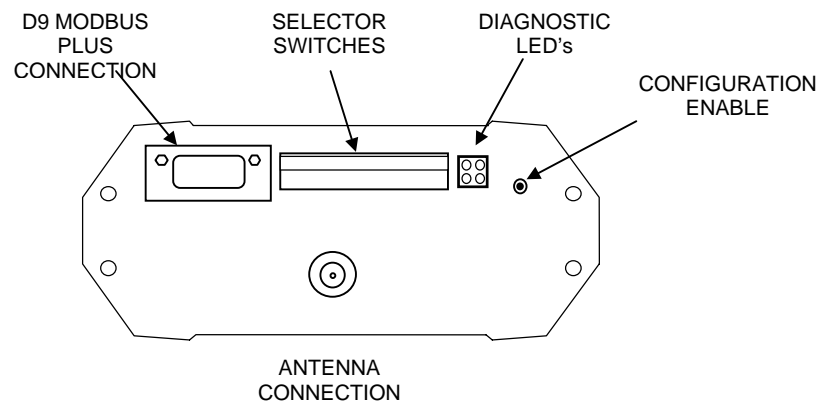

See section on configuration for description of selector switches.

Modbus Plus 9-pin D-SUB Connector:

Pin	Name
1	Cable Shielding
2	MBP Line B
3	MBP Line A
Housing	PE

3.9 DeviceNet Port

For 905U-G-DE1 modules only.

Connection to the DeviceNet Network is via the 5-pin pluggable screw terminal connector located at the antenna end of the module. Pin-outs are specified below.

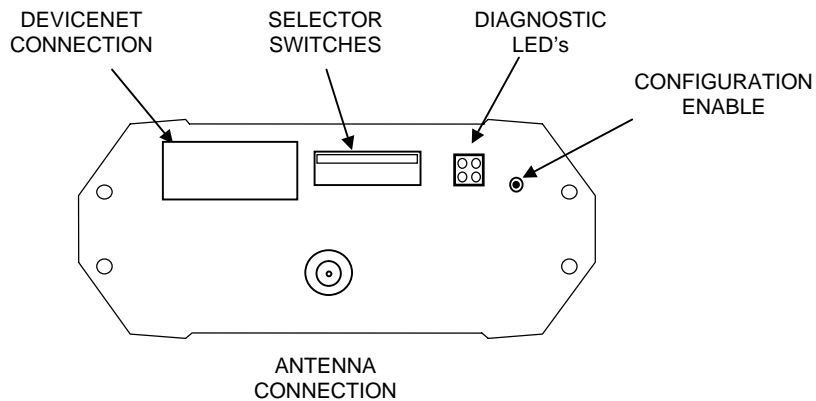

5-pin pluggable screw terminal fieldbus connector:

Pin	Signal	Description
1	V-	Negative Supply Voltage
2	CAN_L	CAN_L bus line
3	SHIELD	Cable shield
4	CAN_H	CAN_H bus line
5	V+	Positive supply voltage

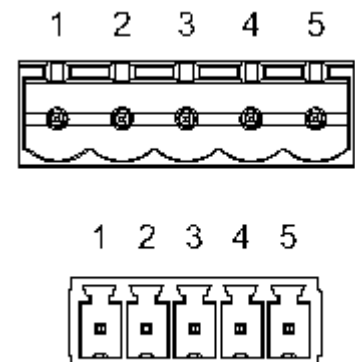

DeviceNet uses termination resistors at each physical end of the bus. The termination resistor should be 121 ohm. This should be connected between CAN_H and CAN_L on the bus.

Chapter 4 CONFIGURATION

4.1 Introduction

A Windows program is provided to configure the 905U system. The configuration is done on a system basis - referred to as a "project" in the program. After the system configuration is entered, the configuration file can be loaded into each module via the RS232 port.

Each Project is configured with:

- a system address, which is common to every module in the same system, and is used to prevent "cross-talk" between modules in different systems. Separate networks with different system addresses may operate independently in the same area without affecting each other. The system address may be any number between 1 and 32 767. The actual value of the system address is not important, provided all modules in the same system have the same system address value. **A system address of zero should not be used.** The configuration program automatically offers a random number for the system address - you can change this to any number in the valid range but we recommend that you use the random number.
- a password for access protection. This is an optional feature. If selected, the project file can only be opened by entering the correct password.
- a security encryption key, used to encrypt and decrypt radio messages. This is an optional feature. If selected, the configuration program will offer a random security key, or this can be over-written with your own key. A key is a string of any 8 ASCII characters.

Each module in the project is configured with a unit address. Each module must have a unique unit address within the one system. A valid unit address for a 905G is 1 to 95. A network may have up to 95 addresses communicating directly via radio (unit addresses 1 to 95). 905U I/O modules can have up to 31 modules communicating via RS485 (unit addresses 96 to 127).

The configuration program may allocate more than one unit address to a 905G if it is required because of the size of the system. If this is necessary, it will be done automatically by the configuration software.

Configuration consists of:

1. selecting the types of modules in the system and selecting address values
2. linking (called "mapping") I/O registers to remote I/O
3. setting operating parameters such as change sensitivities and update times
4. selecting "block mappings" - only for block transfer of I/O registers between 905G modules
5. selecting fieldbus addressing, and serial port configuration (Modbus & DF1 only)
6. linking Radio Interface registers to Fieldbus Interface registers (All modules except MD1)

All of these steps must be performed to configure the 905G module.

4.2 Configuration Program

The configuration software is available on a CD, and needs to be installed on your PC before you can use it. The CD contains a setup file called *setup.exe*. Select the configuration software window on the Product CD and an installation Wizard will guide you through the installation procedure. To upload and download configuration files to a module, you will need a RS-232 serial cable as shown below.

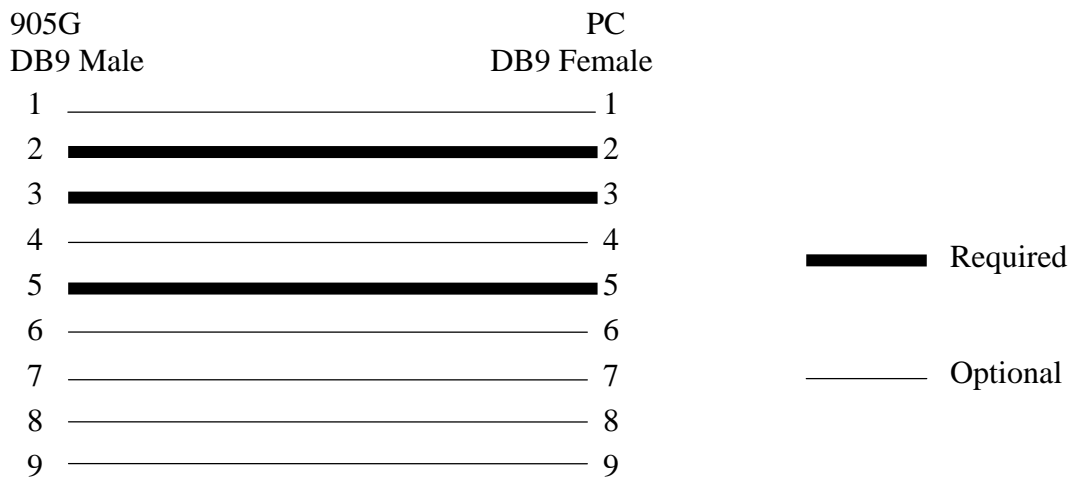

4.2.1 Program Operation

Start the software by either clicking on the start bar and navigating to the Configuration menu or by running ESERIES.EXE in the directory selected in the setup stage.

The Initial screen will appear.

From the initial screen, you can select an existing project, or start a new project. The name of the project will create a new folder which will eventually contain the configuration files for the modules in this system. Project folders are located under the folder \Projects\ - for example, if you create a project called "Fire Pumps", then the files for this project will be found in the folder c:\.....\Projects\Fire Pumps\.

When you have selected the project, a

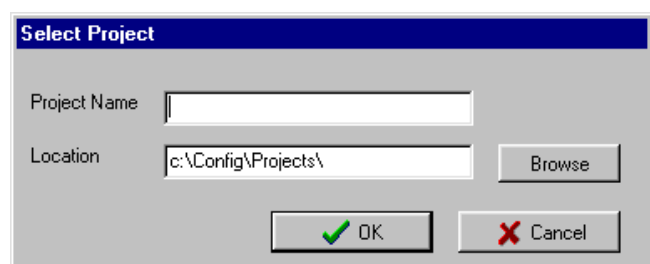
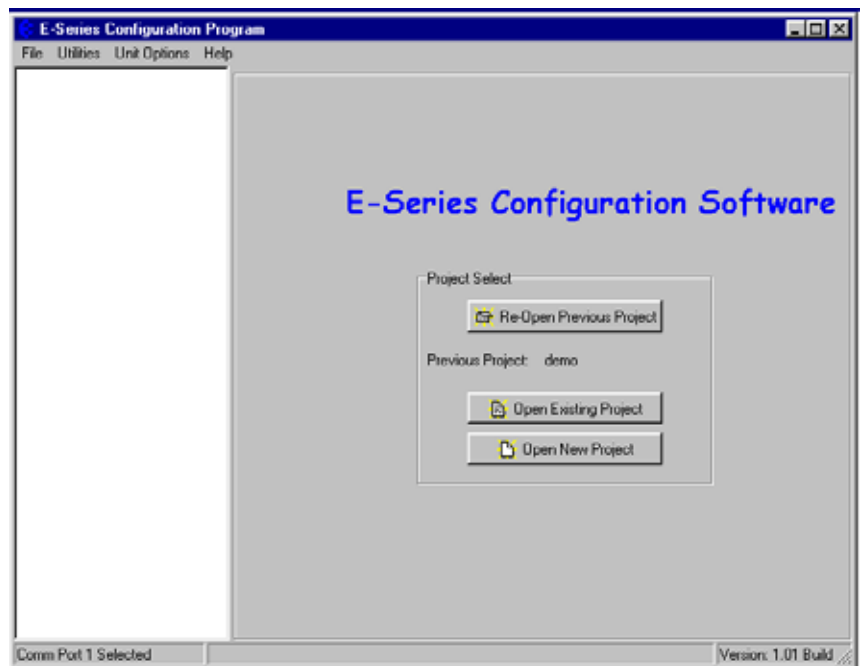

screen will appear where you may enter the system address.

If you are editing an existing project, the system address will already have been entered. Do not change the system address unless you are going to re-program all of the modules in the system.

Password. You have the option of entering a password to protect the configuration files against unauthorized changes. When you open a new project, you will be asked to enter a password - if you do not enter any text - that is, press “ESC” or “Enter”, then password protection is disabled. If you do enter a password, then you will need to enter this password to access the project. Without the password, you are unable access the project

The password can be between 6 and 256 characters. You can also change password at any time by over-typing the password.

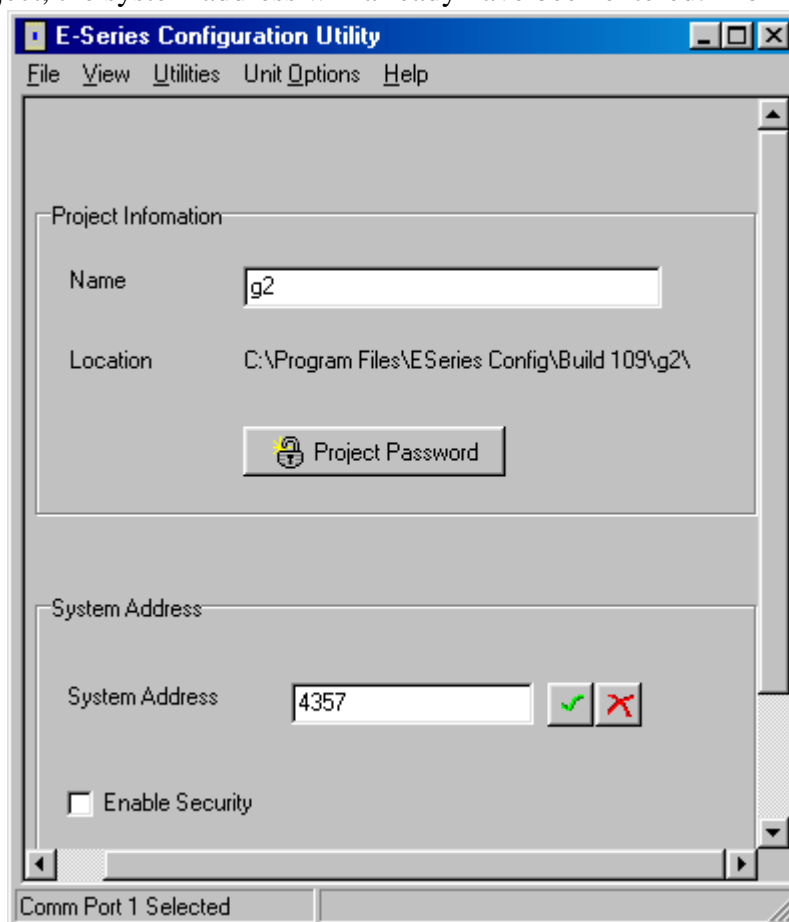

If you are starting a new project, you have the option of “Enabling Security”. This option enables encryption of the data sent over the radio. - please read Section 4.2.2 and the associated warnings before using this option.

To proceed with the configuration, double-click on the project name on the menu on the left side of the screen. “Units” will appear. You can now enter the types of units which will be used in

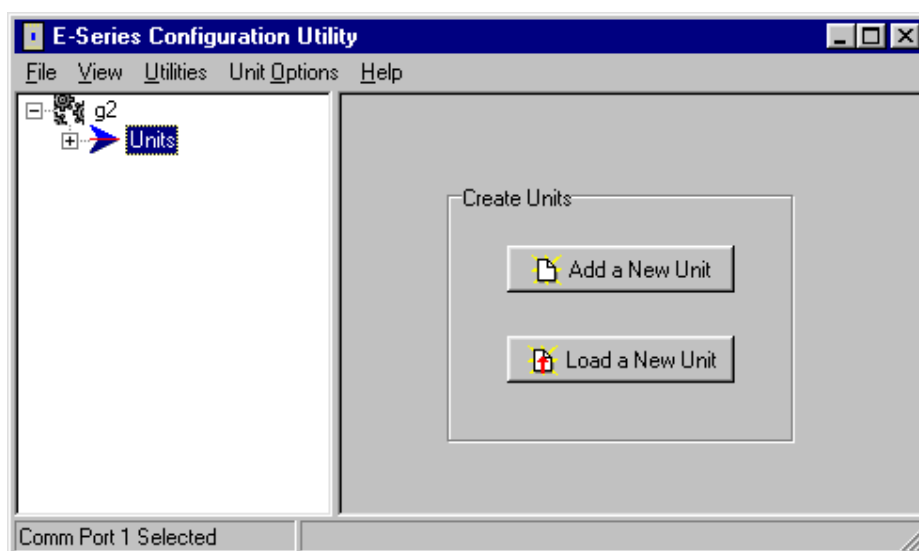

the system. If you double-click on “Units” or select the “+” sign beside “Units”, then the modules that have already been created will be displayed.

Loading configuration from an existing module

To load the configuration from a module, connect the module to the PC via the RS232 cable, put the module into “Configuration Mode” by pressing the configuration button on the top end-plate, and click on “Load Unit”. This will allow you to view the module configuration, change it, or copy it for another module - refer to section 4.10 for full details.

Adding a new module to the system configuration

To add a new module to the system configuration, click on “Units” on the left-hand menu and then “Add Unit”. Select the type of module from the list. For 905G modules, you will be asked to select the bus protocol. This must match the 905U-G module type you have installed.

You have the option of selecting a unit address for the module, or allowing the program to select one automatically. If you choose to select the unit address the program will display the list of available addresses for you to select - valid addresses are 1 – 95.

The default name for a unit will include the unit address. For example, “905-G#10” is a 905U-G module with unit address 10. You can change the name of a unit - for example, you could replace the default name with “Pump Station 14”.

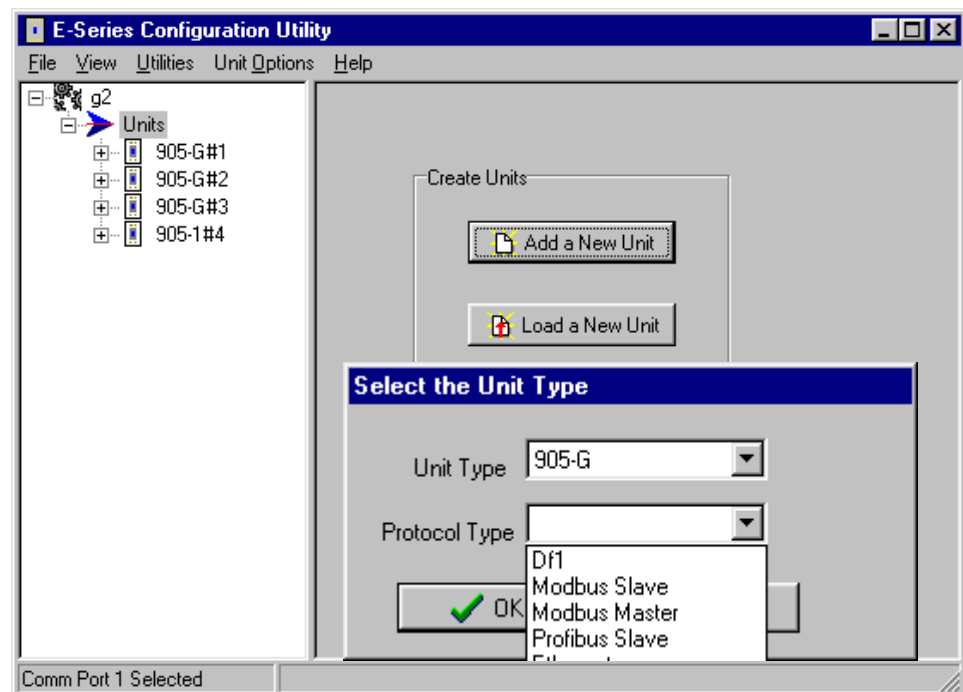
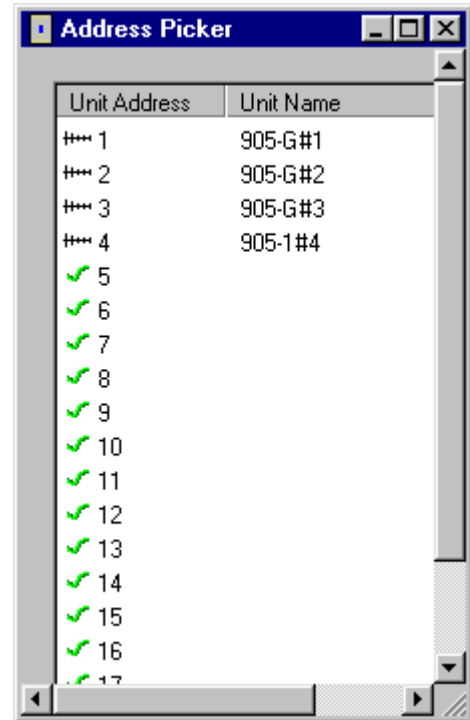

Deleting a Unit

A module can be deleted from the configuration by highlighting the unit and selecting “Delete Unit”.

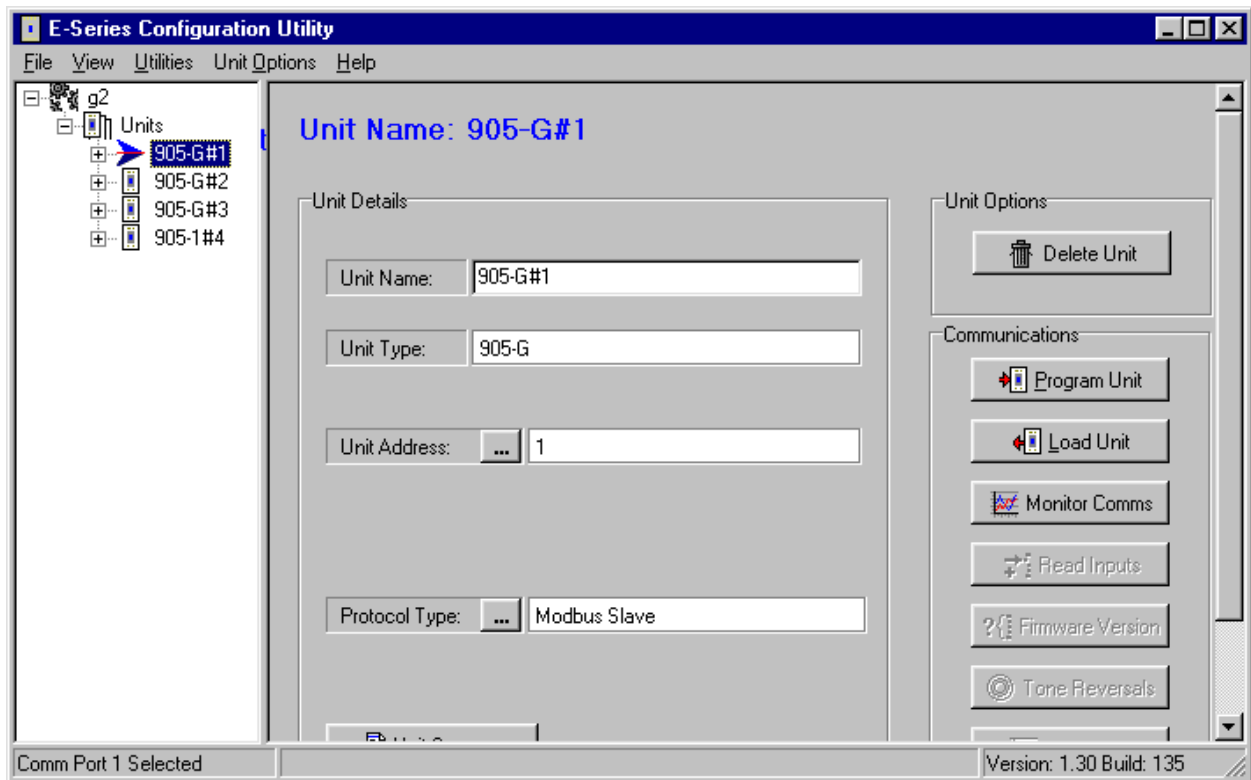

4.2.2 Security

There are two security features available. You can enter a password to protect the configuration files, and you can enable security encryption of the radio transmissions.

The password can be between 6 and 256 characters. The password is case sensitive and any ASCII characters can be used. If you have entered a password, then this password will need to be entered whenever the configuration is changed. You are able to change the password from the “Utilities” menu. If unauthorized access to the files is a concern, we recommend that you change the password regularly or whenever there is a change of staff.

Data Encryption is an additional level of security. The security option uses a 64 bit security key to provide data encryption of the radio messages. All modules in the same system will be configured with the same security key used to encrypt and decrypt the messages. This feature is available for modules with firmware version 2.1 and higher. If you are adding modules to an old system which does not have the security encryption feature, then you cannot use security encryption on the new modules.

Note that the security key is different than the password.

- To enable the security encryption, select the “Enable Security” box on the project display. An 8-character random security key is automatically generated. If desired, a different security key may be entered and you will be prompted to enter the security code a second time to confirm. The security key can be any characters or numbers. Characters are case sensitive. The security key will never be displayed.
- If you do not enable security, there will be no data encryption of the radio messages. This is the default setting.
- If a security key has been entered, this key is downloaded into each module as part of the configuration download process. You can download another configuration at any time - if the security key is different, or if there is no security key in the new configuration, the old key will be over-written.
- You can change the security key in the configuration files simply by entering a new security key in the security key window. You will be prompted to confirm the new security key. Note that if you change the security key, it will not match the security key previously loaded into existing modules.
- If you want to change a configuration, we recommend that you change the archived configuration, and then download the configuration onto the module. The archived configuration already has the valid security key.
- If you lose the archived configuration, you can upload the configuration from a module, but you cannot upload a security key. That is, you can upload the module configuration, view it, change it - but if you don't know the original security key, the old key will be over-written when you download the new configuration. This module will no longer communicate with other modules in the system as the security key is different.

The security options provide security against a “hacker” in the following way:

- ❑ A hacker cannot listen-in to radio messages without the security key to decrypt the radio messages. Similarly, a hacker cannot force outputs by transmitting a radio message to a module without the security key.
- ❑ A hacker cannot access the security key from an installed module or from the configuration files.

-
- ❑ The archived configuration files cannot be changed, downloaded or uploaded without the password.

Warning!!

These security options provide a high level of security, but no data-security system can provide “100% protection”. But it does make it very difficult for someone to interfere with the 905U system - difficult to the point where there would be many easier alternate ways to cause malicious damage.

The password must be kept in a secure place. Security procedures need to be adopted. If staff with access to the password leave your organization, we recommend that the password be changed.

We recommend that you use a random 8-character string for the security key and that you do not record the key. It is not necessary to know what the security key is. The key will be recorded in the archived configuration files, and therefore the configuration files should be held in a secure place and backed up.

The security key does not prevent a hacker uploading a configuration from a module and downloading with a new security key. This module will no longer operate with other modules in the system. To prevent this, unauthorized access to modules must be prevented.

If you lose the configuration files, you can regenerate these by uploading the configuration from every module in the system into a new project with a new security key. After uploading each module, download the configuration with the new security key.

If you wish to change the security key, simply enter a new key in the configuration program, and download the new configuration to all modules in the system.

Note on Ethernet 905U-G. You are able to access the module configuration of an Ethernet 905G via the Ethernet port. To prevent this access, do not select “Enable Ethernet Debug” on the Ethernet configuration display - see section 4.8.

4.3 Mappings 905G to 905U I/O Modules

To transfer remote input signals to a 905G, or transfer a value to a remote output from a 905G, you set up “I/O mappings”. You enter mappings into the source unit, not the destination unit. That is, you configure a mapping at the “input” module. If you want to transfer an input signal at a 905U module to a 905G register, you enter a mapping at the 905U I/O module. If you want to transfer a 905G register to an output signal at a 905U module, you enter a mapping at the 905G module.

To configure mappings, double-click on the module in the left-hand menu - the menu will expand with selections for that module. Select “Mappings”.

Each mapping comprises only one I/O point. “Block Mappings” provide more advanced communications between 905G modules.

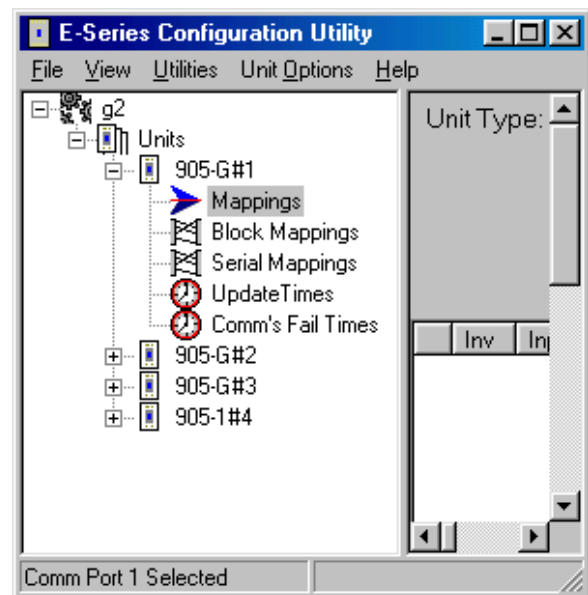

4.3.1 Mappings from Inputs at Remote 905U I/O Modules

Refer to the 905U I/O User Manual.

When mapping inputs to a 905G, you will be asked to select an I/O Register. Select the “...” box beside the “At I/O Register” heading - this will allow you to select the I/O register between 0 and 4299.

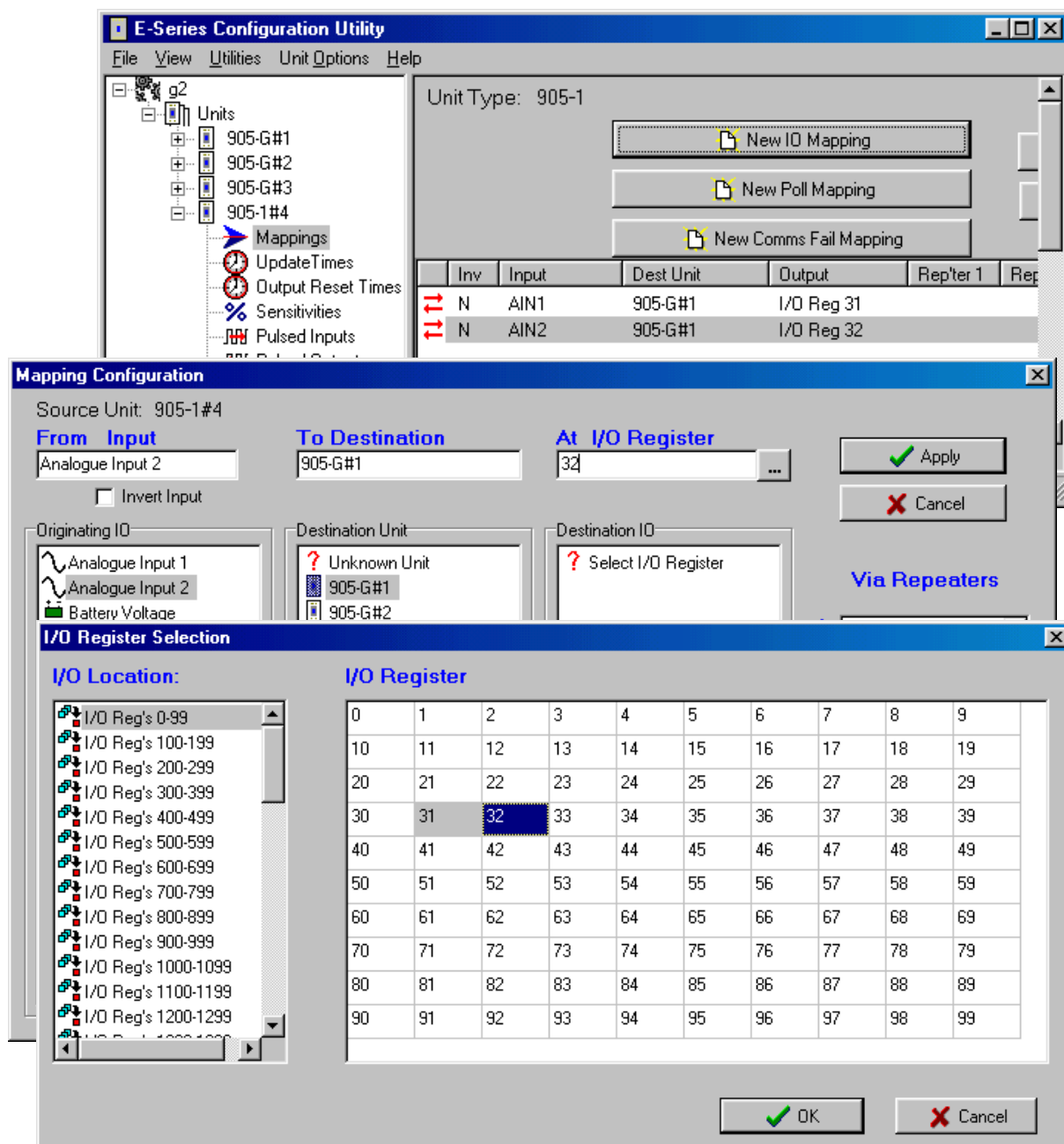

Any I/O registers that have already been selected will have a color shading.

The update times, analog sensitivities for these mappings can be set as per normal I/O mappings.

To map several inputs to consecutive I/O registers, use “Shift”-select or “Ctrl” - select to highlight the inputs, and select the first I/O register in the range. The selected mappings will be entered with consecutive I/O registers.

For each “remote input” configured to a 905G, there is a comms-fail time parameter in the 905G. If the 905G does not receive a message destined to that I/O register within the “comms fail” time, then the “comms fail” status for that I/O register will be set - the most significant bit of the status register will be set to 1. The comms fail time should be more than the corresponding update time at the remote input.

To set the comms fail times, select the 905G, and select the “Comms Fail Time” option. Each remote input already mapped to the 905G will automatically be listed, including the remote module containing the mapping.

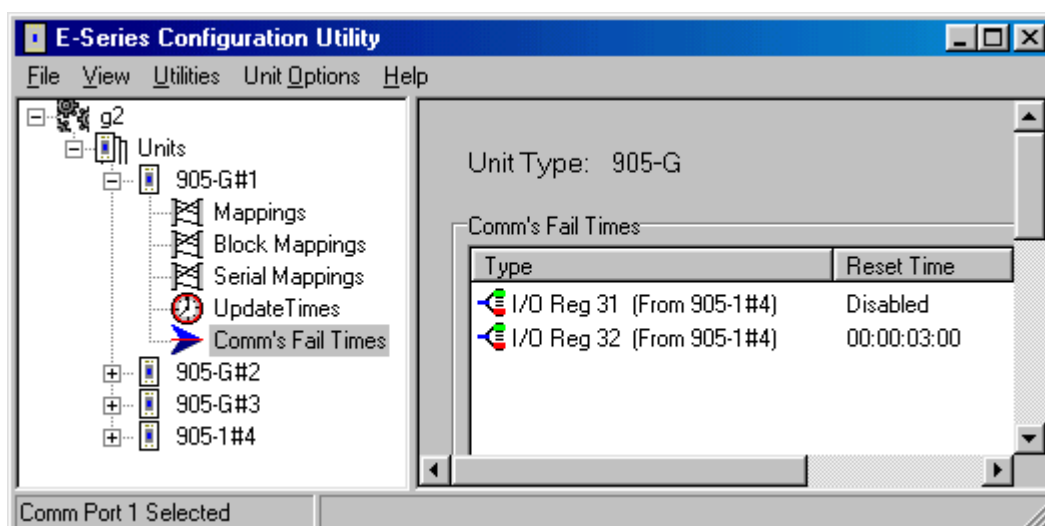

The default value for the comms-fail time is “disabled” or zero. To enter a time, select the I/O register from the list. The comms-fail time should be greater than the update time of the remote input.

4.3.2 Mappings from 905G to Outputs at Remote 905U I/O Modules

Mappings can be entered in the 905G to remote outputs. Select the “Mappings” option under the 905G. Select an I/O register and select the remote module and the output channel.

To map several consecutive I/O registers to several outputs, select the first I/O register in the range and use “Shift”-select or “Ctrl” - select to highlight the multiple outputs. The selected mappings will be entered with consecutive I/O registers.

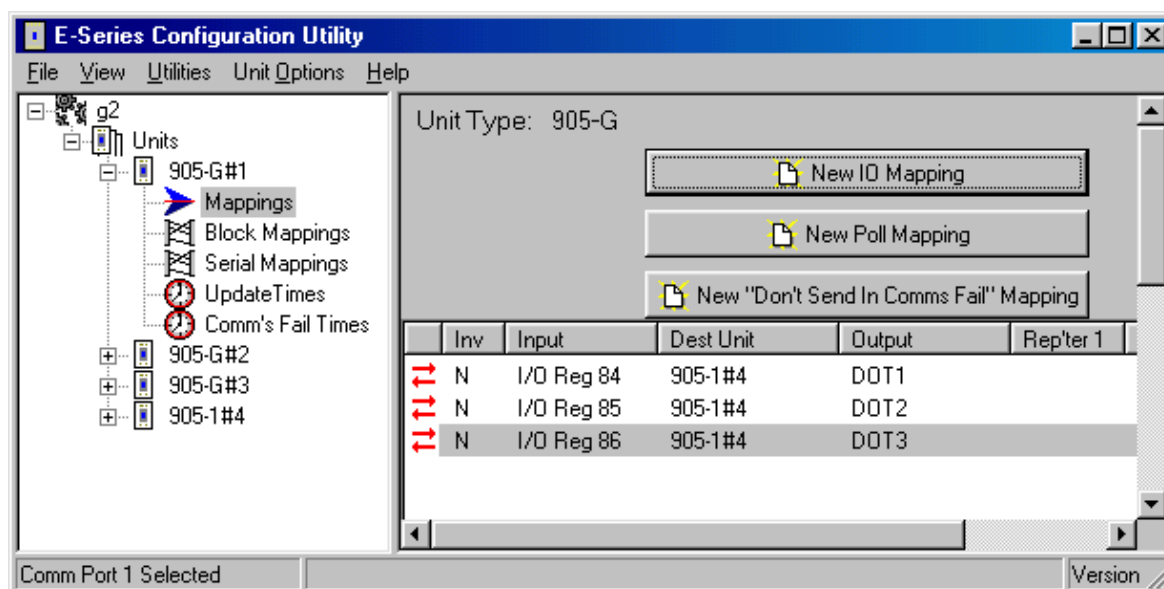

Change Sensitivities

Radio messages to remote modules can change messages (when the value of the I/O register changes) or update messages (when the update time has elapsed). If a change message is sent, the update period restarts.

You can configure the amount of change required to trigger a change message - this is called the change sensitivity. Sensitivities are configured for blocks of I/O registers - that is, each I/O register does not have a unique sensitivity. You can configure up to 50 sensitivity values - that is, there can be 50 blocks of registers with different sensitivities.

For more information on this, refer to section 4.5.

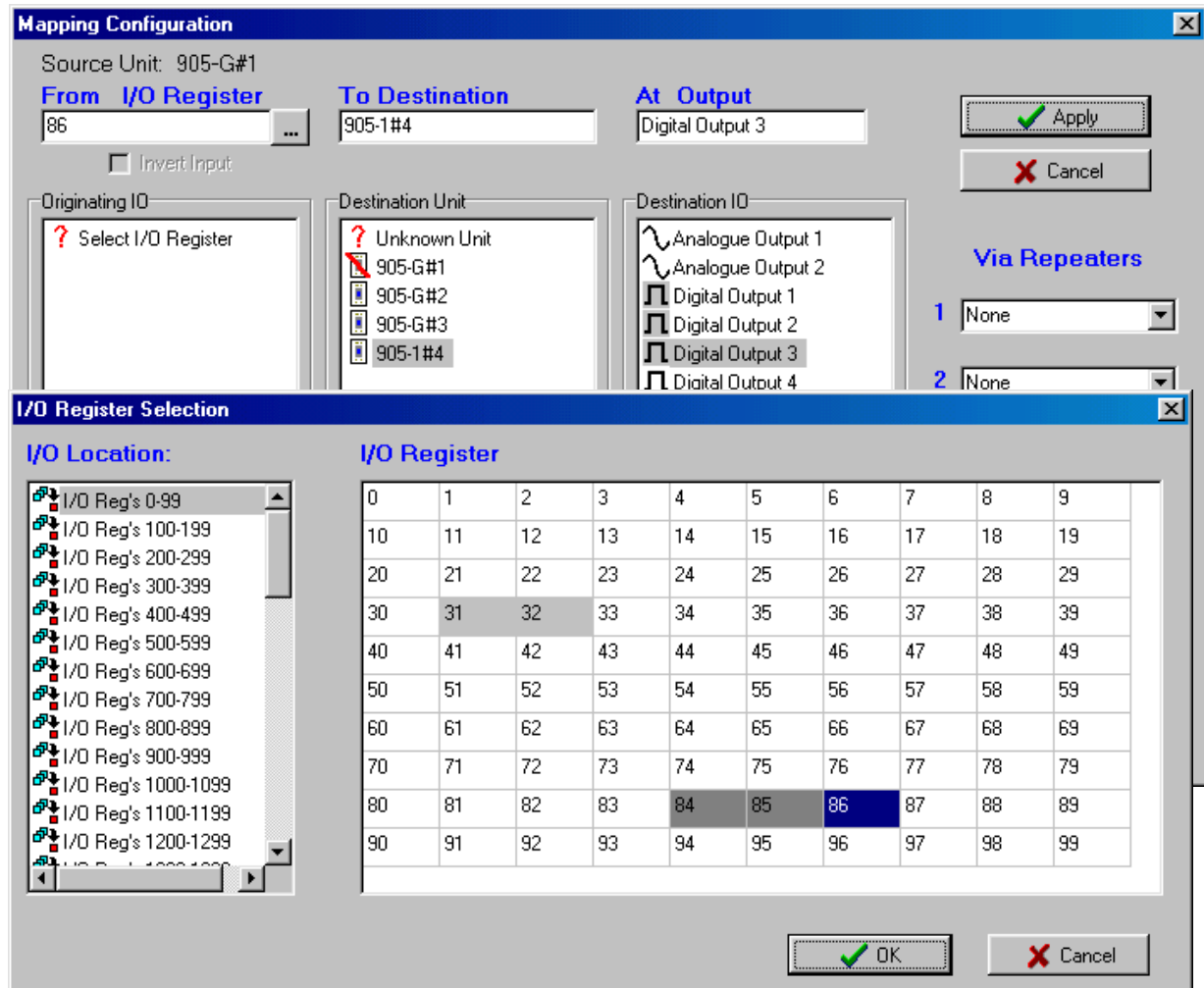

Update Times

To change the update times of output mappings, select the Update Times option. Any I/O registers that have already been mapped to remote outputs will automatically be listed. The default update time is 10 minutes.

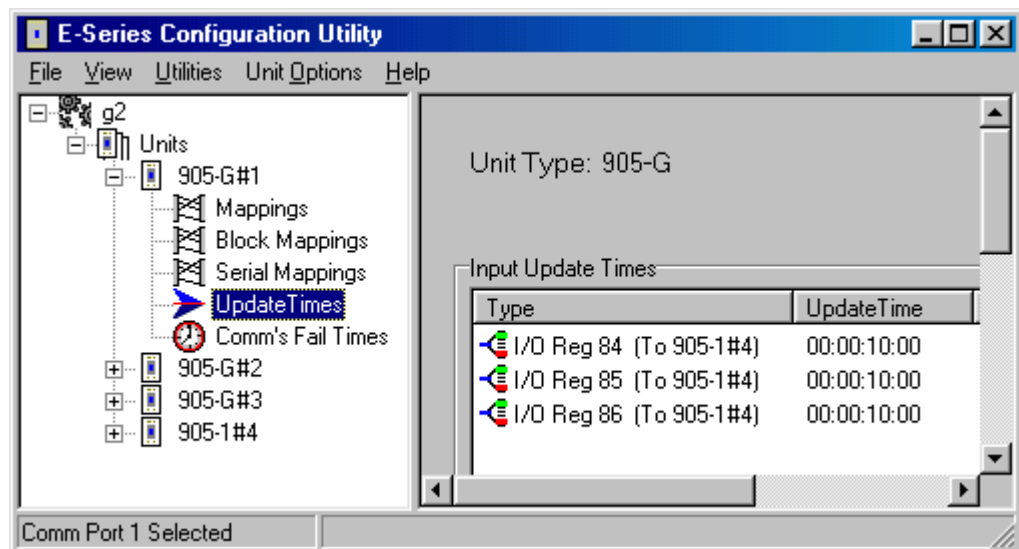

Changing Multiple Settings

You can change the Comms Fail Times or Update Times of several I/O points simultaneously by using the <Shift> Select feature. For example, if you want to change all times to 1 minute, you could change each individually, or you could “block” all entries using the “Shift” Select feature and select “Edit”. You only need to enter the change once to change all of the inputs selected. This feature is also available with the other configurable parameters.

4.3.3 Don't Send if in Comm Fail

You can configure a special “Don't Send if in Comms Fail” mapping. If this is configured for a particular remote module, the 905G will not transmit output messages to this remote address, if there is a communications failure status on any input or output configured for the

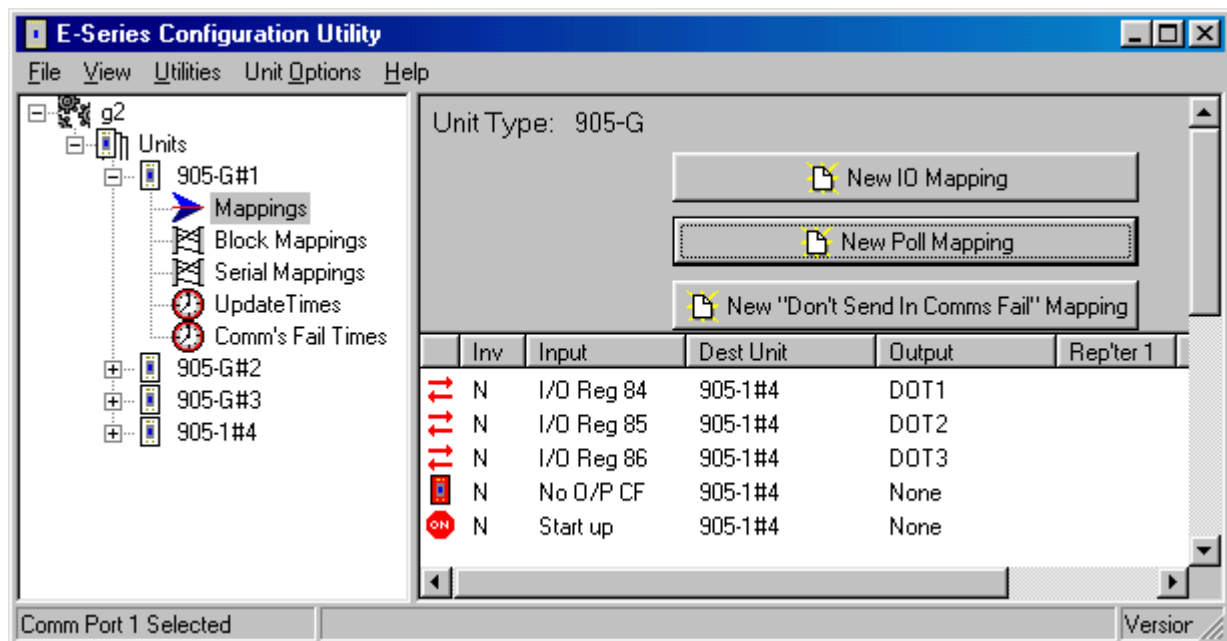

same remote address. Output messages will re-start when a message is received from the remote module. The use of this option can prevent the radio channel becoming congested if there are many outputs at that module.

To configure this special mapping, select the “New Don’t Send in Comms Fail Mapping” box. You will be asked to select which remote module this function applies to. You can enter more than one of these mappings if there are more than one modules.

4.3.4 Startup Polls

You can enter start up polls for remote modules by using the “New Poll Mapping” box. This function is the same as for the 905U I/O modules. A start-up poll is a special message sent when the 905G starts up. When the remote module receives a start-up poll, it will immediately respond with update messages for all its inputs that are mapped to the 905G. This allows the 905G to have correct values on start-up.

4.3.5 Polls to Remote Modules

It is possible for a 905G to send a poll to a remote module at other times apart from start-up. A poll can be sent under the following events:

- based on a configurable time period
- based on real time clock
- on-demand by the host device.

For information on this configuration, refer to the next section on “Block Mappings”.

4.4 Mappings from 905G to other 905G Modules

Individual links between 905G modules can be configured under the “Mappings” selection as described in the previous section. For example, if you want to transfer I/O Reg 144 in 905G#2 to I/O Reg 286 in 905G#3, you can enter the following mapping:

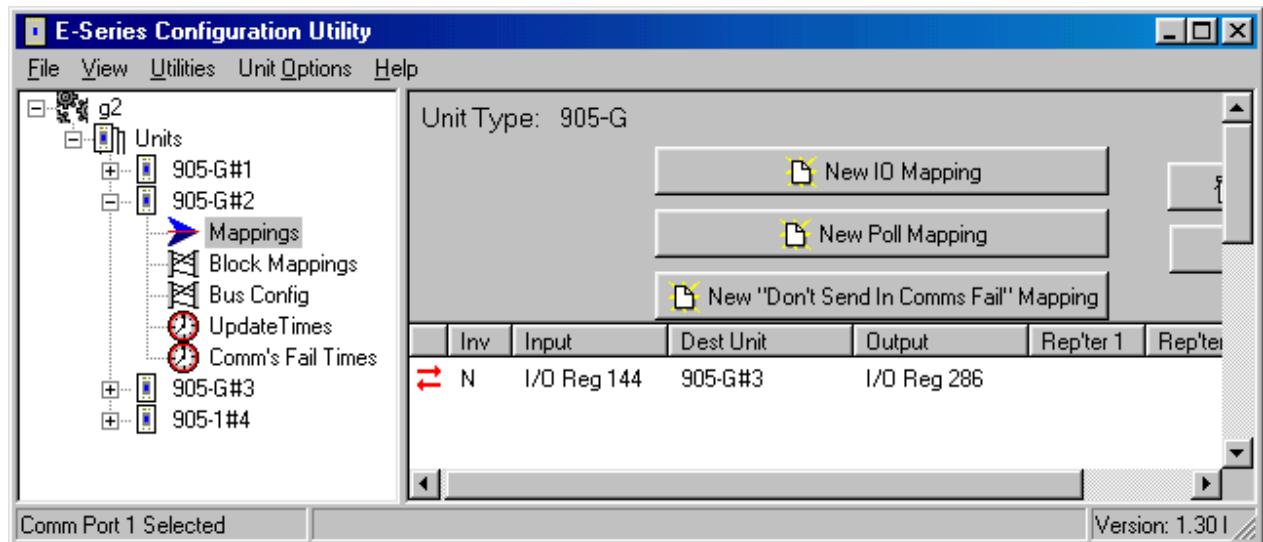

Whenever I/O Reg 144 changed by the sensitivity amount, 905G#2 would send a message to 905G#3 to write the value in I/O Reg 286. The problem arises if there are a lot of these mappings. Each radio message only relates to one register-register link. If you want to map 1000 registers from one 905G to another, then this could generate a lot of radio messages.

To get around this problem, it is possible to configure “block mappings”. With a block mapping, multiple registers (a “block of registers”) can be transferred together in the one radio message. This improves the efficiency of the radio communications.

Read/Write Mappings

The mappings can be “read” or “write” mappings. A Read mapping is a request sent to another 905G to return a block of values. A Write mapping is a message sending a block of values to another 905G. A Read mapping from 905G#2 to 905G#3 could be the same as a Write mapping from 905G#3 to 905G#2 (that is, in the reverse direction) - except the Read mapping is initiated from #2 and the Write mapping is initiated from #3.

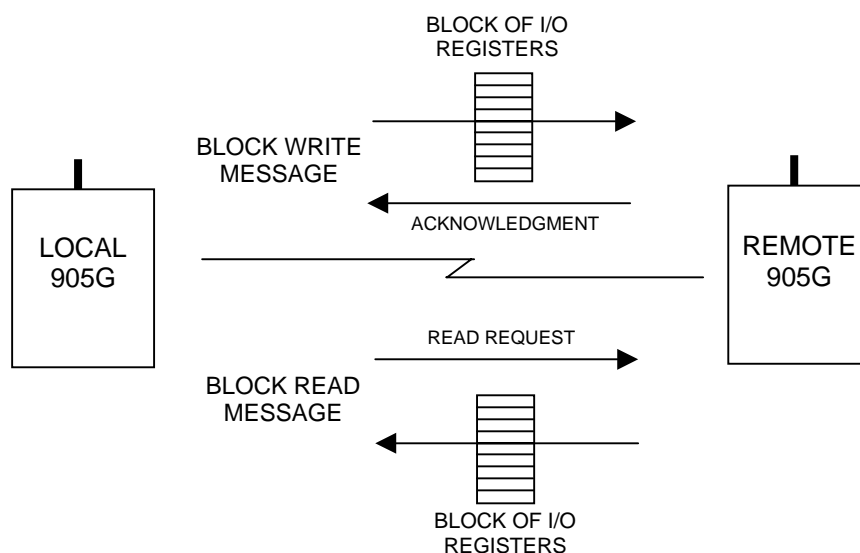

Word/Bit Mappings

Read and Write mappings are also selected as Word or Bit mappings - that is, you can select a Read Word mapping or a Read Bit mapping and you can select a Write Word mapping or a Write Bit mapping. “Word” refers to a complete 16-bit register value; “Bit” refers to the value of the most significant bit of a register - this bit is the “binary value” or “digital value” of the register.

If you use a Word block mapping of 50 registers, you are transferring a block of 50 x 16-bit values. If you use a Bit block mapping of 50 registers, you are only transferring the digital value of each register - that is 50 x 1 bit values. This is a lot more efficient for a radio message, but bit mappings are only suitable for discrete or digital I/O. A Bit mapping will convert the 16-bit register to a single bit, transfer it and store the bit value in the most significant bit of the destination register.

Note: The maximum block size for each block mapping is 64 registers.

4.4.1 Entering a Block Mapping

Select the “source” 905G on the left hand menu - select “Block Mappings” and then “New Block Mapping” from the right-hand display. The Block Mapping Configuration display will appear.

Select the “Command Type” from the pop-down window in the centre of the display. The red arrow will confirm the direction of the block transfer. Now select the destination module - only the 905G modules already configured will be shown. If you need to use repeaters in the radio link, enter the repeater addresses, starting with the repeater closest to the source module.

Under “Source Gateway”, enter the I/O Register and I/O Count. The I/O Register is the first register in the block and the I/O Count is the number of registers - in the above example, the block of registers will be 110 – 124 (15 registers starting at I/O Reg 110).

If you are entering a Write mapping, then the values in this block will be sent to another 905G. If it is a Read mapping, then values from another 905G will be sent to this block.

Under “Destination Gateway”, enter the I/O Register - this is the first register in the block. You do not need to enter the block size as this will always be the same as the block size in the source 905G. In the above example, the destination block will be I/O registers 32 – 46 (15 registers starting at register 32). So, in the above example, a block of 15 x 16-bit values will be written from I/O Reg 110 – 124 in 905G#1 to I/O Reg 32 – 46 in 905G#2.

Each mapping entered is allocated a status register - the register number appears on the right hand of the Block Mapping display. These registers store relevant status information about the block mapping - the structure of the Block Mapping status registers is shown in Appendix 1.

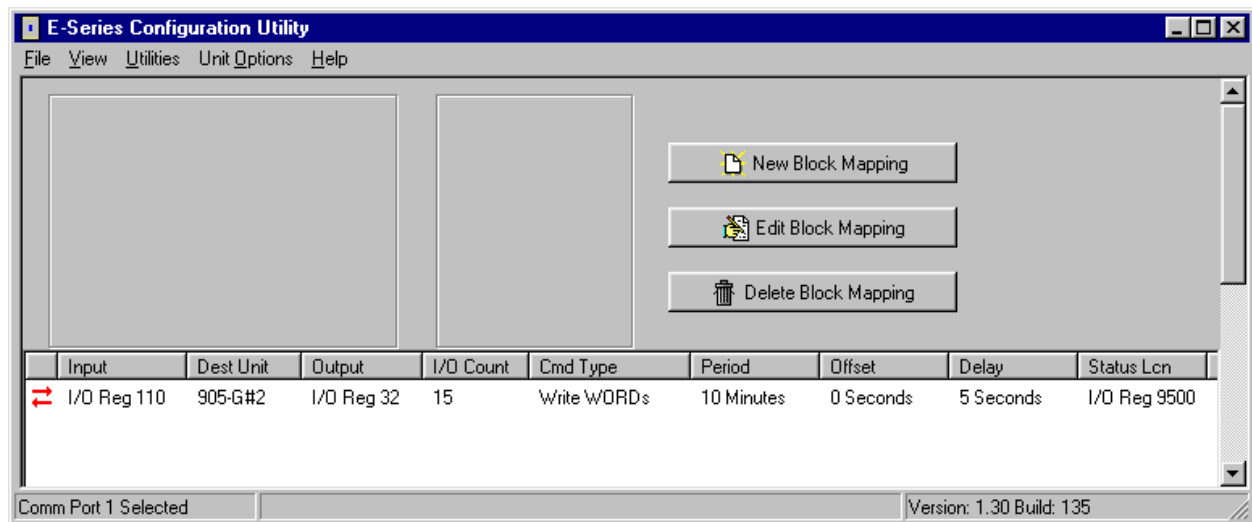

In the above example, the status register for the block mapping has been automatically assigned to register 9500.

The rest of the mapping configuration involves the mapping trigger - or what initiates the mapping message.

Mapping “Triggers”

A block mapping can be “triggered” or initiated by several different methods.

- By the host device writing to a “trigger register” in the source 905G - the block mapping message is sent each time the host device writes to the trigger register.
- By configuring a time period - the 905G will send the block mapping message if this time period has elapsed since the last message has been sent.
- By configuring a real-time clock - the 905G will send the block mapping message at the configured times.
- By a change-of-state within the I/O block. This can only occur for Write mappings. If a value in the block changes by more than the sensitivity amount, then the block message will be sent. You can enter a delay period such that the message is sent after the delay period.

Combinations of the above triggers can occur - for example, the block mapping message will be sent if a change-of-state occurs, AND at the configured real-time, AND when the host device writes to the trigger register.

4.4.2 Host Device Trigger

Each block mapping that is configured is allocated a status register in the range 9500 – 9999 (i.e. one status register for a maximum of 500 possible block mappings). The status register for a given block mapping is shown on the right hand side of the Block Mapping display (under the heading “Status Lcn”). Bit 13 of the associated status register is the “Force bit” - if Bit 13 is turned “on”, then the associated mapping is forced, or triggered. Depending on the module version, a particular algorithm may apply to the setting of the force bit. This algorithm and details of the block status registers are given in Appendix 1.

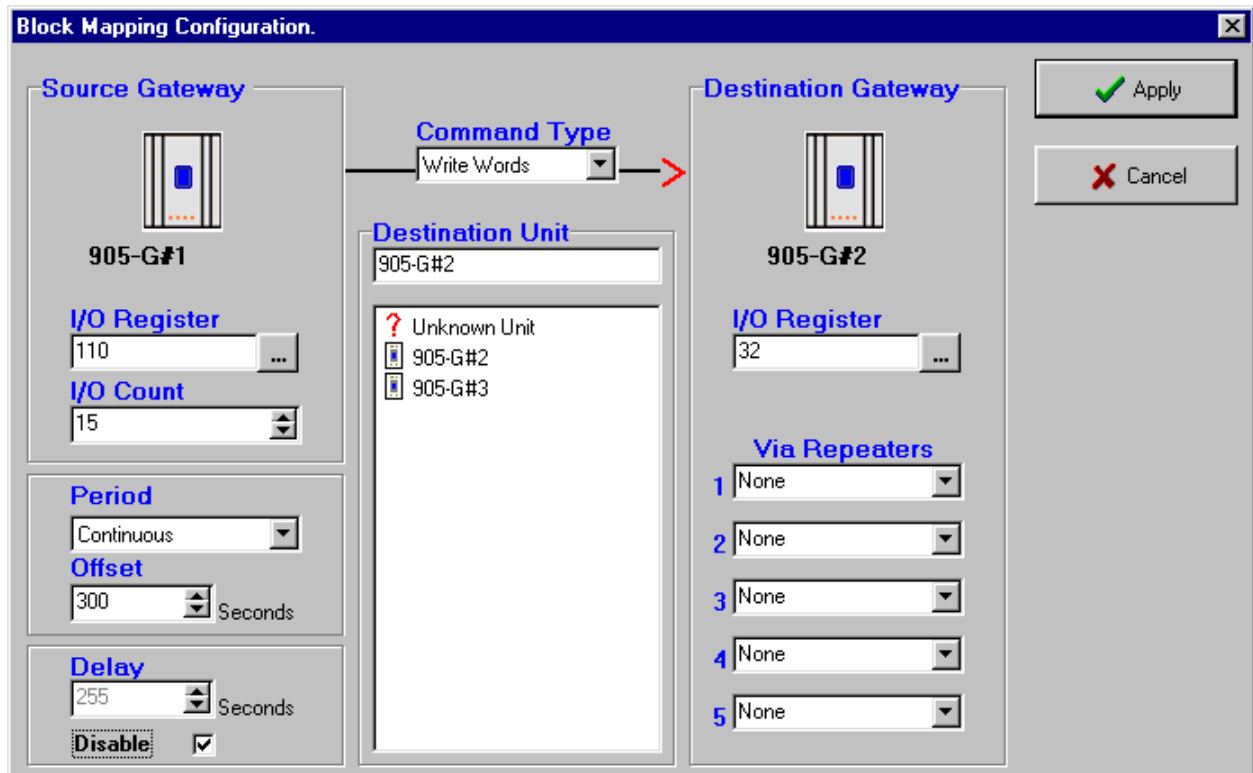

4.4.3 Time Period

On the Block Mapping display, there are two configuration windows - “Period” and “Offset” - these determine the time period trigger and real-time trigger.

For a time-period trigger, select “Continuous” in the “Period” pop-down window. Under “Offset” enter the time-period in seconds. In the above example, the mapping will be sent every 300 seconds or 5 minutes.

Note that the time period is after the last transmission - if the block mapping message is triggered by the host device, or by a change-of-state, then the timer is reset and the time period starts again.

The “Offset” value can be set from 0 – 4095 seconds (68 minutes). If you do not want the message to be sent on a time period, set the “Offset” value to zero.

If you want the block mapping to be sent only on time period (and not on change as well), select the “Disable” box in the bottom left hand corner - this disables change messages for this block mapping.

4.4.4 Real-Time

The block mapping message can be sent at a real-time by setting the “Period” value. In this example, “period” is set to 6 minutes - the message will be sent every 6 minutes starting at the beginning of each hour. That is, the message will be sent at XX:00, XX:06, XX:12, XX:18, XX:24 XX:54 - where XX represents any hour of the day.

If “Period” was set to 1 minute, then the message would be sent every minute, on the minute.

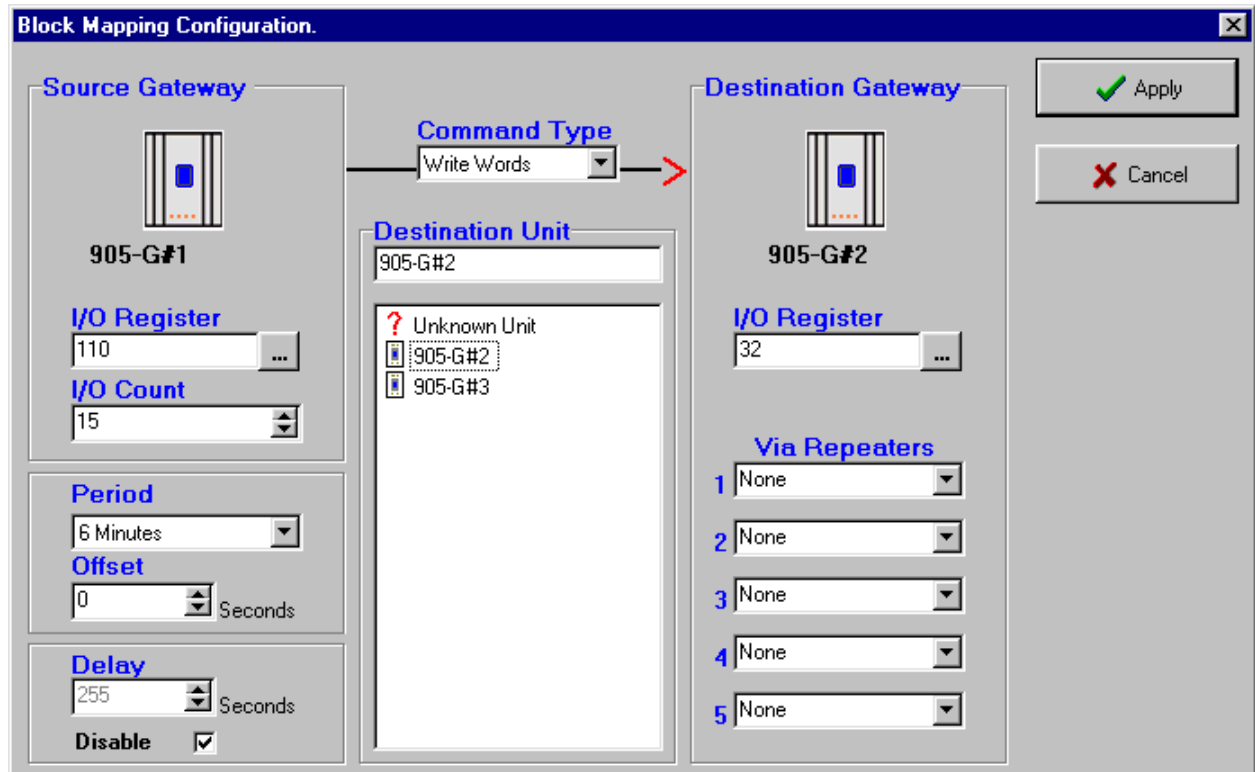

The “Offset” value provides an offset to the specified time. In this example, if the “Offset” was set to 10 seconds, then the messages will be sent 10 seconds later - at XX:00:10, XX:06:10, XX:12:10 etc.

The reason for the offset is to stagger messages with the same time setting. For example, if you configure 5 block mappings all to be sent at 10 minutes, then the 905G will try to send these messages at the same time - some of the messages will have to wait until the earlier messages have been sent. If you are sending Read messages as well as Write messages, then the return messages could clash with outgoing messages.

To avoid this, you can delay some messages using the Offset feature. For example, if you have 5 mappings to be sent at 10 minutes, then the first could have zero offset, the second 3 sec offset, the third 6 sec offset etc.

If you do not wish to have a real-time trigger, set “Period” to continuous.

If you want the block mapping to be sent only on real-time (and not on change as well), select the “Disable” box in the bottom left hand corner - this disables change messages for this block mapping.

Setting the Clock

The clock within the 905G can be set by the host device, and read by the host device. The 905G provides four clock registers for days/hours/minutes/seconds - the registers are 4330 –

4333. On power-up, these registers are set to zero. Reg 4333 increments each second, Reg 4332 increments each minute, Reg 4331 each hour and Reg 4330 each day.

The clock registers are used by the 905G for the real-time-clock trigger. The host device can read these registers. The host device can also set the 905G clock at any time by writing to the appropriate *Set* register. The *Set* registers are : 4340 – 4343. The procedure for setting the real time clock via these registers depends on the module firmware version (to find out what firmware version the module contains, simply display the diagnostics menu – see section on diagnostics). The *set registers* can also be set via radio using appropriate I/O or block mappings.

Item	Clock Location	Set Location
Days	4330	4340
Hours	4331	4341
Minutes	4332	4342
Seconds	4333	4343

Firmware versions up to 1.50:

Registers 4340 – 4343 are normally zero. When a value is written into one of these registers, the 905G copies the value into the corresponding clock register, and then sets the *Set* register back to zero. For example, if the host device writes a value of 7 into Reg 4341, the 905G will write 7 into 4331 and set 4341 back to zero.

Firmware version 1.50 and later:

Registers 4340 – 4343 will only be transferred to the corresponding clock registers when their value changes from 0. For example to write a value of 7 to the hours register, first write the value 0 to the *Set hours* register 4341, then write the value 7 to the same register. (i.e. by always first writing the value 0 to the *Set* register this ensures that the change-of-state from 0 will be detected). Values must be held (i.e. not change) for approx 200msec to be detected.

4.4.5 Change-of-State

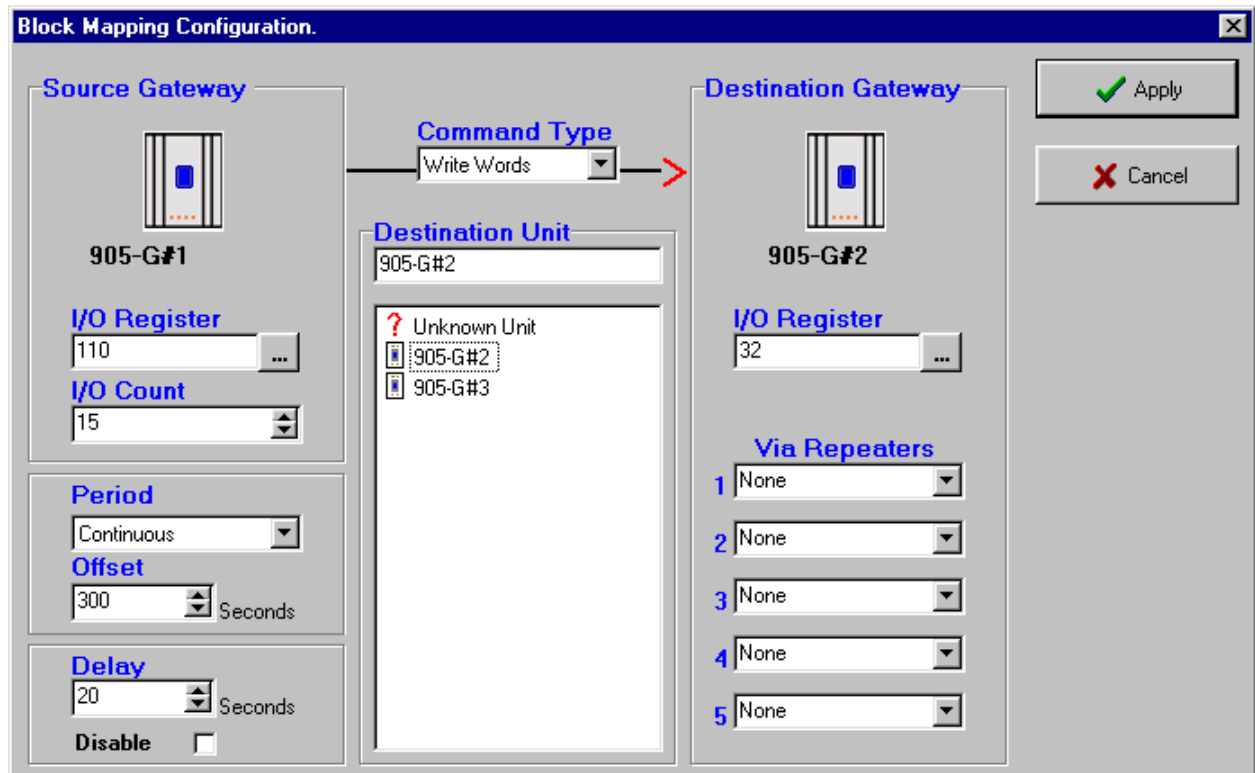

If a value in the block changes by more than the sensitivity amount, then the block message will be sent (this can only occur for Write mappings). The sensitivity values are set under the “Sensitivity” option as per section 4.5.

A delay time can be entered to reduce the number of change triggers in active systems. For example, if 20 seconds is selected in the “Delay” window, then the change message will be sent 20 seconds after the change-of-state occurs - if other changes occur during the 20 second period, all of these changes are sent in the one message.

The delay time can be set from 0 – 254 seconds.

If you do not wish change messages to occur, select the “Disable” box.

4.4.6 Mixing Normal Mappings and Block Mappings

Block mappings can include I/O Registers already used with normal I/O mappings.

For example, a remote 905U I/O module could map a remote input to I/O Reg 743. At the 905G, the host device could read I/O Reg 743, and you could also configure a block mapping including this register to another 905G. You could write a block I/O Reg 700 – 800 to another 905G.

4.4.7 Comms Fail for Block Mappings

Each block mapping has an associated mapping number. Up to 500 block mappings may be entered. A status register is maintained for each block mapping. The most significant bit of this register contains the comm fail status.

If a block mapping does not receive an acknowledgement from the remote module, then the comms fail status is set - this can be monitored by the host device.

4.4.8 “Repeater-only” Configuration

Any 905G module can act as a repeater unit. However a 905G may need to be installed as a repeater only (that is, there is no host device connected). In this case, the base 905G, the 905U-G-MD1 unit would normally be used as this is the lowest cost of the 105G modules.

A repeater can be configured as a “Repeater-only” unit. The advantages are:

- the serial port will then provide on-line diagnostics (instead of off-line diagnostics), or
- 105S serial I/O modules can be connected to the serial port - normally 105S modules cannot be used with MD1 units.

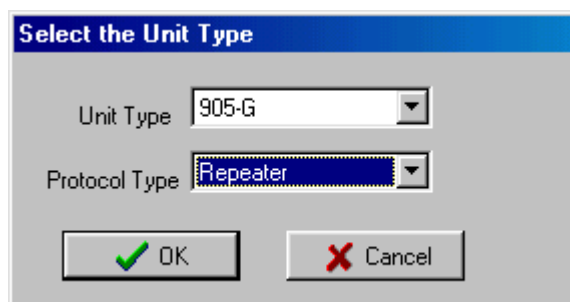

4.5 Change Sensitivity

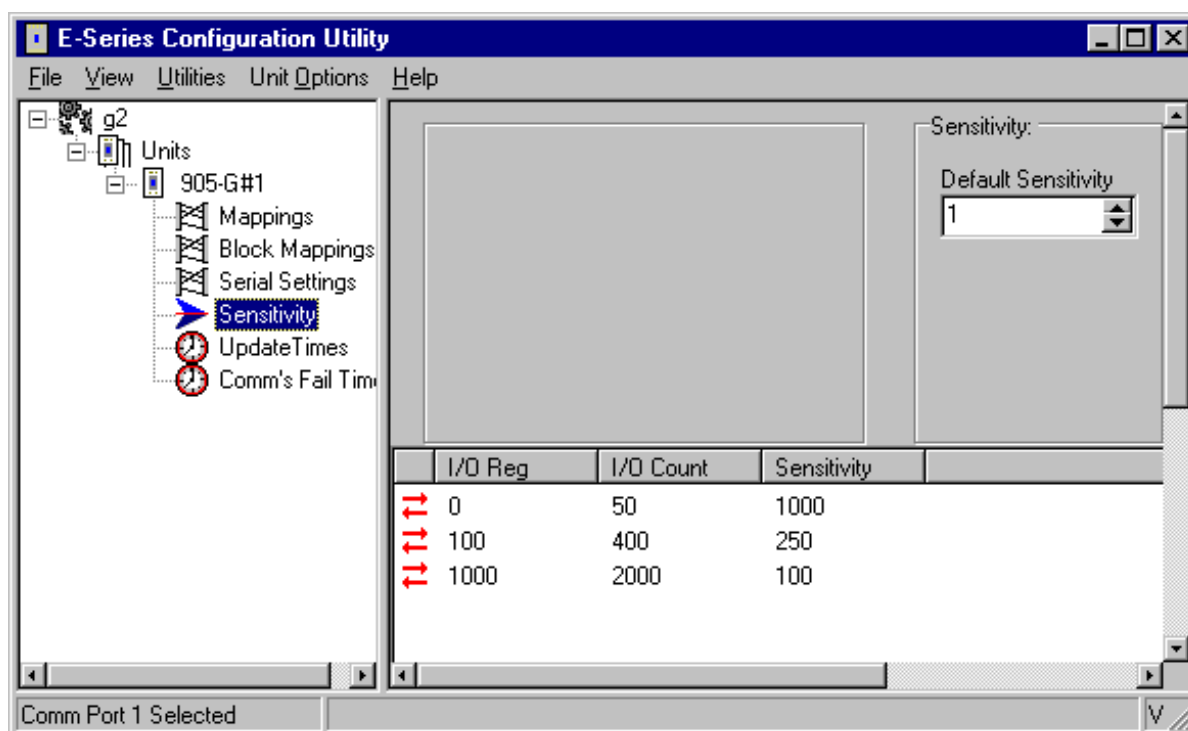

“Change” messages for both individual I/O mappings and block mappings use a sensitivity value to trigger the message. Sensitivities are configured for blocks of I/O registers - that is, each I/O register does not have a unique sensitivity. You can configure up to 50 sensitivity values - that is, there can be 50 blocks of registers with different sensitivities.

In the above example, three sensitivity blocks have been configured:

1. I/O registers 0 – 49 have a sensitivity of 1000 (or 1.5% of the 16 bit range)
2. I/O registers 100 – 499 have a sensitivity of 250 (or 0.4% of the 16 bit range)
3. I/O registers 1000 – 2999 have a sensitivity of 100 (or 0.15% of the 16 bit range)

All of the registers between 0 and 49 have a sensitivity value of 1000. If register 34 has changed value by more than 1000 since the last transmission for that register, then a change

trigger will occur for register 34. Sensitivity values are in decimal and can vary between 1 and 65535 (16-bit).

Up to 50 blocks of sensitivities can be configured. If a register is included in more than one block, then the first sensitivity value configured will be accepted and later values ignored.

Registers which are not included in any block use the “default” sensitivity which is also user-configurable. In the above example, the default sensitivity is 1 and is the sensitivity for all I/O registers not included in the three blocks.

Important Note. Sensitivity values need to be selected carefully for analog or counting registers as small values can result in a large number of change messages, which can overload the radio channel. A sensitivity value of 1 in 65535 is a change of 0.0015%. If the host device writes an analog value to a 905G every 100msec, it will change by at least 1 bit each time. A small sensitivity value will cause a change message to be sent every 100msec. If there are many analog values in the same situation, then there would be many change messages every 100msec. Sensitivity values for analog I/O should be set to be greater than the normal process noise of the signal. For example, if a flow signal has a normal process oscillation of 2.5%, then the sensitivity should be set to 3% (or a value of 2000) to avoid change transmissions from the process oscillations.

4.6 Serial Configuration - MODBUS

The 905U-G-MD1 module provides interface for Modbus Slave, Modbus Master and Allen-Bradley DF1. This Modbus interface uses the Modbus RTU protocol - also known as the Modbus Binary protocol. This manual assumes that the reader has a good understanding of the Modbus or DF1 protocol.

4.6.1 MODBUS Slave

If you use the 905G Modbus Slave interface, then the host device will be a Modbus Master device. The only configuration required for the Modbus slave interface is selecting the Modbus address and serial port parameters. This is done in the “Serial Settings” screen. A valid Modbus slave address is 1 to 255.

Each I/O register (and status register) in the 905G can act as one of the following types of Modbus registers

00001-09999 = Output Coils (digital/single bit)

10001-19999 = Input Bits (digital/single bit)

30001-39999 = Input Registers (analog/16 bit)

40001-49999 = Output Registers (analog/16 bit)

For example:

- If the Modbus Master sends the 905G a “read” command for Modbus input 10457, then the 905G will respond with the value in I/O register 457.
- If the Modbus Master sends the 905G a “write” command for Modbus output 02650, then the 905G will write the value to I/O register 2650.
- If the Modbus Master sends the 905G a “read” command for Modbus input 30142, then the 905G will respond with the value in I/O register 142.
- If the Modbus Master sends the 905G a “write” command for Modbus output 40905, then the 905G will write the value to I/O register 905.

The 905G I/O register values are 16 bit (hexadecimal values ‘0000’ to ‘FFFF’, or decimal 0 to 65535), regardless of whether the register represents a discrete, analog or count point.

The value of a discrete (digital) I/O point is stored in the 905G database as a hexadecimal '0000' (“off”) or hex 'FFFF' (“on”). However the 905G will respond with either a ‘0’ (“off”) or ‘1’ (“on”) to a digital read command from the Modbus master - these are commands 01 and 02. Similarly, the 905G will accept ‘0’ or ‘1’ from the Modbus master in a digital write command and store ‘0000’ or ‘FFFF’ in the database location - these commands are 05 and 15.

The modbus function codes that the 905G will respond to are shown in the table below.

Supported Modbus Function Codes:

Function Code	Meaning
01	Read the state of multiple digital output points
02	Read the state of multiple digital input points
03	Read the value of multiple output registers
04	Read the value of multiple input registers
05	Set a single digital output ON or OFF
06	Set the value of a single output register
07	Read Exception Status - compatibility - returns zero
08	Loopback test Supported codes 0 return query data 10 clear diagnostic counters 11 bus message count 12 CRC error count 14 slave message count
15	Set multiple digital output points ON or OFF
16	Set multiple output registers

Analog I/O are 16 bit register values. A value of decimal 8192 (hex 2000) represents 0mA. A value of 49152 (hex C000) represents 20mA. Each 1 mA has a value of 2048 (hex 0800) - a change of 4096 (hex 1000) is equivalent to a change of 2mA. A 4-20mA signal will vary between 16384 (hex 4000) and 49152 (hex C000). A 0-20mA signal will vary between 8192 (hex 2000) and 49152 (hex C000).

Pulse counts are stored as a 16-bit register. When the register rolls over, from 'FFFF' (hex), the next value will be '0001'. The register will only have a value of '0000' when the remote module starts up, and the previous count is lost. This value will indicate that the counter has reset.

Modbus Errors

Four Modbus error messages are reported to the Modbus Master. An error response is indicated by the address of the return message being 128 plus the original slave address.

Supported Exception Codes:

Exception Code	Name	Description
01	Illegal function	The module does not support the function code in the query
02	Illegal data address	The data address received in the query is outside the initialized memory area
03	Illegal data value	The data in the request is illegal
06	Busy	Unable to process message

4.6.2 MODBUS Master

If you use the 905G as a Modbus Master, then the host device/s will be Modbus Slave

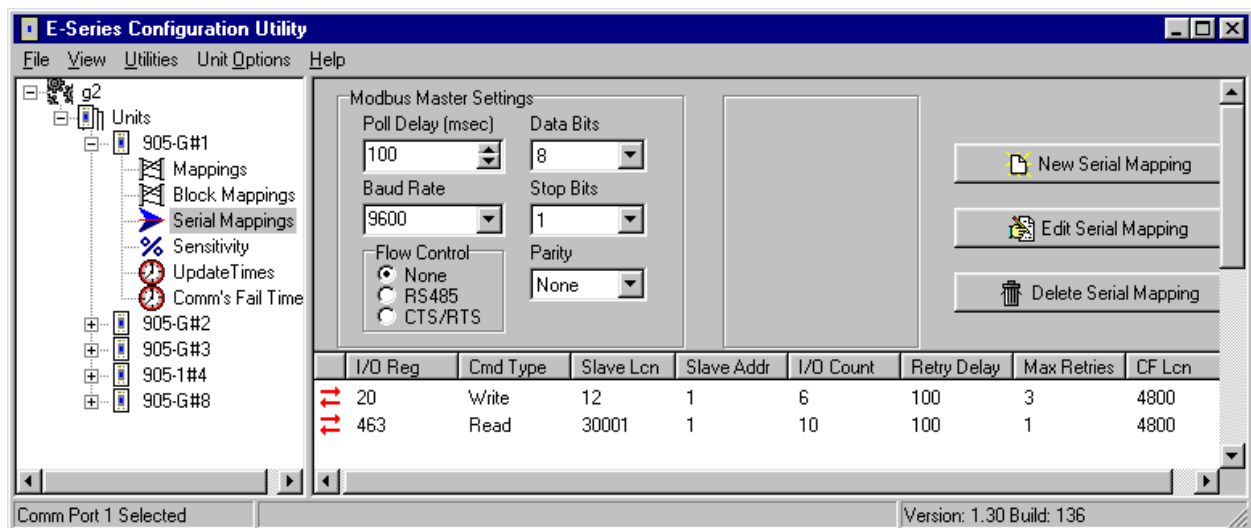

device/s. If the RS485 port is used, then multiple Modbus Slave devices can be connected to the 905G. The 905G Modbus Master will generate Modbus read and write commands to the Modbus Slave devices.

First read the above section on Modbus Slave operation, for an understanding of how the 905G handles Modbus registers, and the types of Modbus commands the 905G Master can generate.

The Modbus Master commands are configured in the “Serial Mapping” screen. The serial port is configured in the same way as described in the above section on Modbus Slave.

To enter a Modbus command, select “New Serial Mapping”. The following example is a digital write command which writes 905G I/O registers 20 – 25 (6 registers) to Modbus outputs 00012 – 00017, at Modbus Slave address 1.

The entry under “I/O Register” is the first I/O register in the 905G to be transferred - the “I/O count” is the number of registers to be transferred. If the selected Modbus slave does not respond to the command, then the 905G will write a ‘FFFF’ value to one of its own registers, configured under “CF Register” - in this case it is register 4800.

The “Command Type” selected is a write command (you can select read or write) - which means that the values are sent from the 905G to the Modbus Slave. The type of write

command is a “Digital” write, meaning that the register values will be written as digital/binary values”.

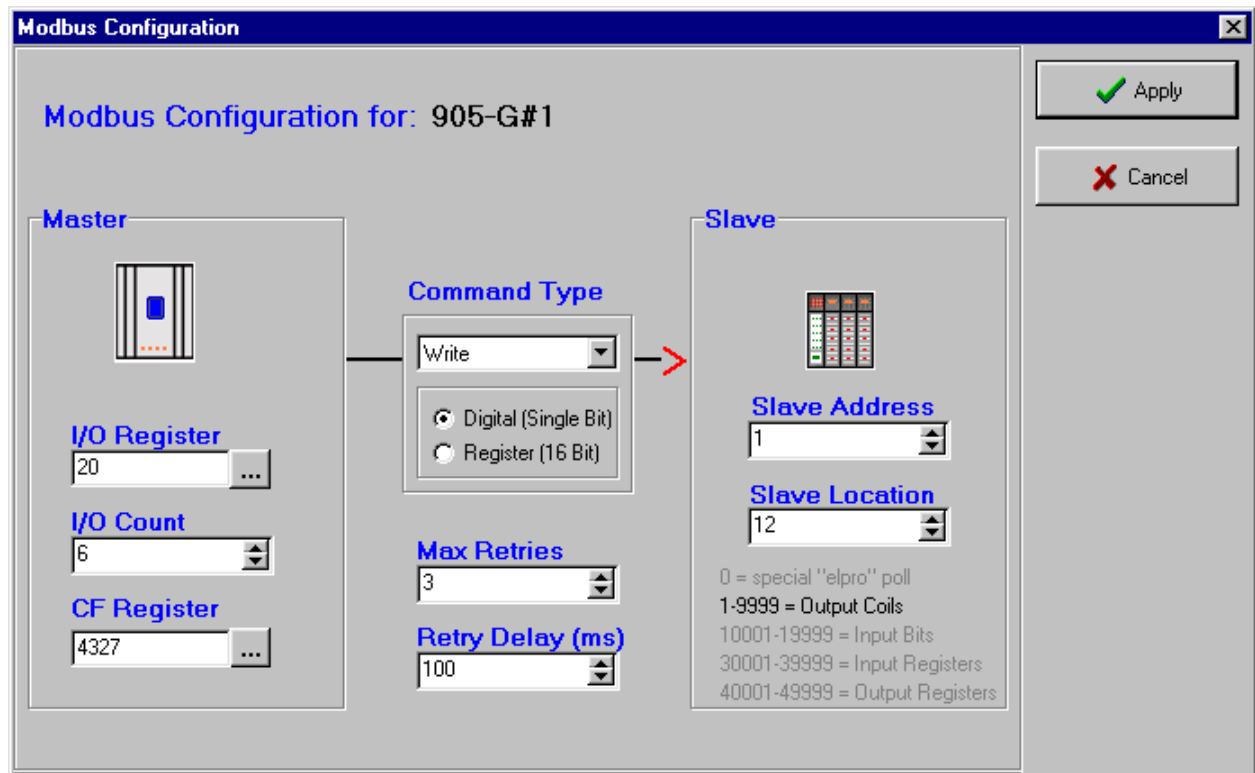

If the Modbus Slave device does not respond to the Modbus command, the 905G will try another 3 times (“Max Retries” = 3). The Modbus command will be sent to the Modbus Slave every 100msec. The address of the Modbus Slave is 1 (permissible addresses are 1 – 255). Because a digital write command has been selected, the destination register type will be digital outputs, with Modbus tag “0xxxxx”. The first destination Modbus location is 12 (or 00012) - as there are 6 registers transferred, the destination locations will be 00012 – 00017.

The second example is a register read command to the same Modbus Slave (address 1). The command requests the Modbus Slave to return the values of 10 registers which will be stored in I/O registers 463 - 473 in the 905G. As the command is a “register read” command, the target Modbus locations will be of the type 3xxxx. The starting location is 30001. So the values of locations 30001 – 30010 in Modbus Slave 1 will be transferred to I/O registers 463 – 473 in the 905G.

The CF Register (“comms fail” register) acts as a digital alarm – the value of the register will normally be 0, and will be set to FFFF (hex) if the slave device does not positively respond to the serial command within *Max Retries* attempts. In the examples, the same CF Register (4327 – i.e. DOT8) has been used for both serial mappings, such that the local digital output will be activated if the slave fails to respond to either serial command. Alternately, any other internal register could have been chosen and mapped via radio if desired.

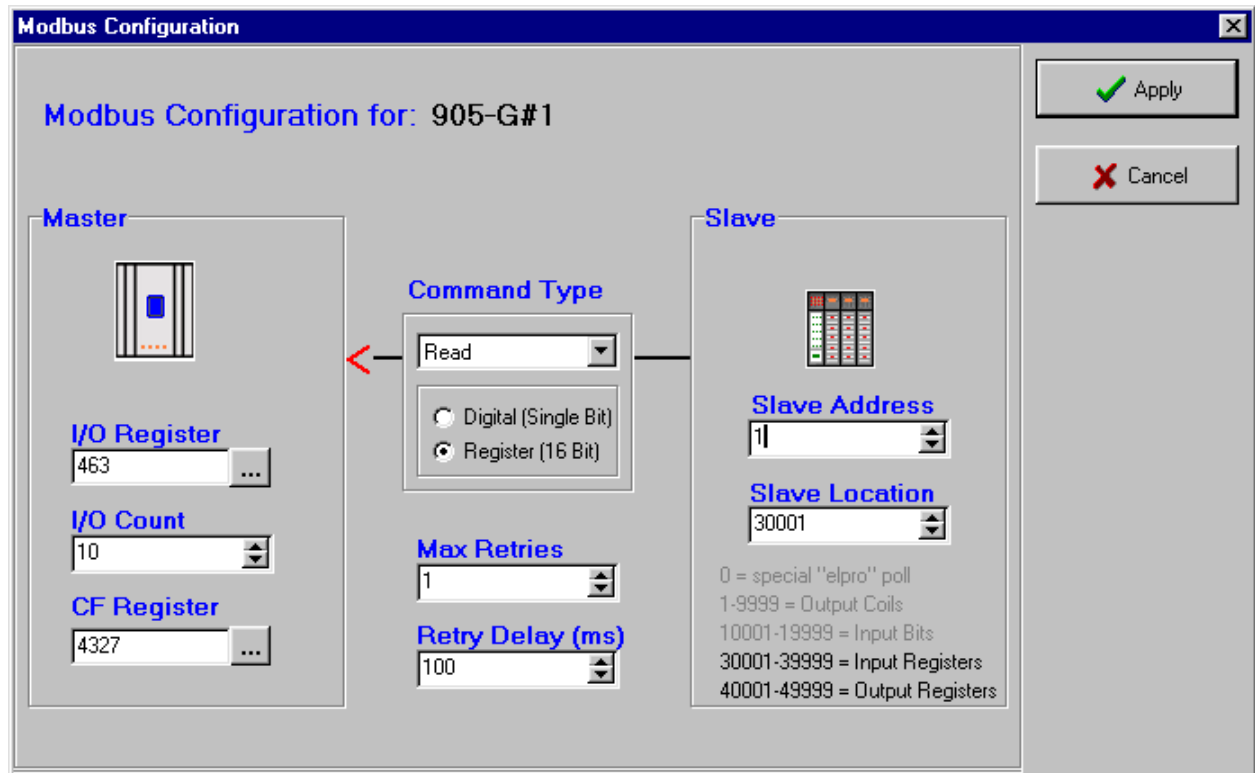

To complete the Fieldbus Configuration, enter any other Modbus commands that may be required to transfer I/O points between the 905G and the Modbus Slave devices.

Digital I/O

The value of a digital I/O point is stored in the 905G database as a hexadecimal '0000' ("off") or hex 'FFFF' ("on"). However the 905G will generate either a '0' ("off") or '1' ("on") to a digital output point (Coil) when sending commands to a Modbus slave - these are commands 05 and 15. Similarly, the 905G will accept '0' or '1' from the Modbus slave in response to a digital read command and store '0000' or 'FFFF' in the database location - these commands are 01 and 02.

Analog I/O

Analog I/O from the remote 905U modules are 16 bit register value. A value of 8192 (hex 2000) represents 0mA. A value of 49152 (hex C000) represents 20mA. Each mA has value of 2048 (hex 0800) - a change of 4096 (hex 1000) is equivalent to a change of 2mA. A 4-20mA signal will vary between 16384 (hex 4000) and 49152 (hex C000). A 0-20mA signal will vary between 8192 (hex 2000) and 49152 (hex C000).

Pulse I/O

Pulse counts from the remote 905U modules are shown as a 16-bit register. When the register rolls over, from 'FFFF' (hex), the next value will be '0001'. The register will only have a value of '0000' when the remote module starts up, and the previous count is lost. This value will indicate that the counter has reset.

Modbus Retry Delay

The 905G Modbus Master configuration includes a feature to limit the frequency at which slave devices are polled for data. The 905G will poll each Modbus slave in order. If there is no delay time entered, the 905G will poll as quickly as it is able to. If there is a delay time entered, then this delay time will occur between each poll message.

When updated values are received from the 905U radio network, the current polling sequence is interrupted, and the new values are written immediately to the appropriate slaves.

Re-tries on the Serial Port

When communicating with Modbus slaves, the 905G may be configured to re-try (or re-send) a message zero or more times if no response is received from a slave. If all retries are used up, that slave is flagged as being in communication failure. Further attempts to communicate with the slave will have zero re-tries. When a successful response is received from the Modbus slave, the communication failure flag is reset and the configured number of re-tries will be used. This means that an off-line slave device will not unduly slow down the communications network.

Comms Fail

A “Comms Fail” image location in the 905G database. This image location should be in the range 4500 to 4999. If a response is not received from the Modbus slave after all re-tries have been sent, the 905G will set this Comms Fail image location to hex(FFFF). When the 905G sends the next poll for this I/O Command, it will not send any re-tries if a response is not received to the first message. When a response is eventually received, the 905G will reset the value in Comms Fail image location to 0, and the normal re-try sequence will operate.

Different I/O Commands can use different Comms Fail image locations, however we recommend that you use the same image location for all I/O Commands to the same Modbus slave address.

4.7 Serial Configuration - DF1

The 905G DF1 Driver allows the 905G to communicate with Allen-Bradley devices supporting the DF1 protocol. Supported commands allow communication with 500 CPU devices (SLC and Micrologix) and with PLC2 series devices. DF1 offers both full-duplex (point to point) and half-duplex (multidrop) operation. The 905G only supports the full-duplex operation - this is the default DF1 mode on most equipment. DF1 full-duplex is a “peer-to-peer” protocol. Either DF1 device can initiate commands to the other device, and both devices will respond to commands from the other device. The 905G can act as both a command initiator and a command responder.

An Application Note and configuration files are available describing how to configure an Allen-Bradley PLC to communicate with a DF1 905G. This is available from the Elpro website www.elprotech.com
--

The 905G will initiate the following command types to a command responder, according to the configuration. The 905G will automatically generate the correct command type depending on the configuration you enter. The 905G will also respond to these command types if they are sent from a command initiator.

Command Description	Code	Function Code	Comment	
Protected Write	0x00	NONE	PLC2 series and SLC / Micrologix	
Unprotected Read	0x01	NONE	PLC2 series and SLC / Micrologix	
Diagnostic Status	0x06	0x00	Diagnostic Commands	
Echo message	0x06	0x00		
Unprotected Write	0x08	NONE	PLC2 series and SLC500 / Micrologix	
Typed logical Read	0x0F	0xA2	Type	SLC500 and Micrologix
Read Bits	0x0F	0xA2	0x85	Reads MSB of each 905G I/O register and writes the bits to the destination register, starting at the LSB of the register. Min. transfer is 16 bits.
Read Integers	0x0F	0xA2	0x89	Return signed 16 bit value
Read Long Ints	0x0F	0xA2	0x91	Unsigned 16 bit register per long-word
Typed logical Write	0x0F	0xAA	Type	SLC500 and Micrologix
Write Bits	0x0F	0xAA	0x85	Writes bits from the source register, starting at the LSB, to the MSB of a block of 905G I/O registers. Min. transfer is 16 bits.
Write Integers	0x0F	0xAA	0x89	Writes a signed 16 bit value
Write LongIntegers	0x0F	0xAA	0x91	Low 16 bits of long-word placed in register. Upper 16 bits ignored.

The SLC and Micrologix PLC's read/write two types of registers. An "Integer" has a signed 16 bit value (-32768 to 32767). A "Long Integer" has a 32 bit value. The 905G registers contain an unsigned 16 bit value (0 to 65535). We recommend that you use Long Integer read/write commands - the upper 16 bits of the 32 bit value will be ignored. Refer to more information in the Analog I/O and Pulse I/O sections below. The PLC2 uses unsigned 16 bit registers in the same format as the 905G.

The 905G DF1 driver will update remote outputs whenever a data value changes by more than the I/O register sensitivity. If the response from a data request contains a changed data value, the new value will be transmitted to the remote 905U on the radio network. Similarly, if the 905G receives a command to change a data value, the new value will be transmitted to the remote 905U module.

The DF1 commands are configured in the "Serial Mapping" screen. The serial port should be configured in the same way as the host device. If the 905G acts only as a command responder, no further configuration is required.

If the 905G acts as a command initiator, you can enter a “Request Delay” between commands sent to the host. To enter a DF1 command, select “New Serial Mapping”. The following example is a file write command which writes 905G I/O registers 80 – 104 (25 registers) to DF1 files I3.1 to I27.1 at DF1 address 2.

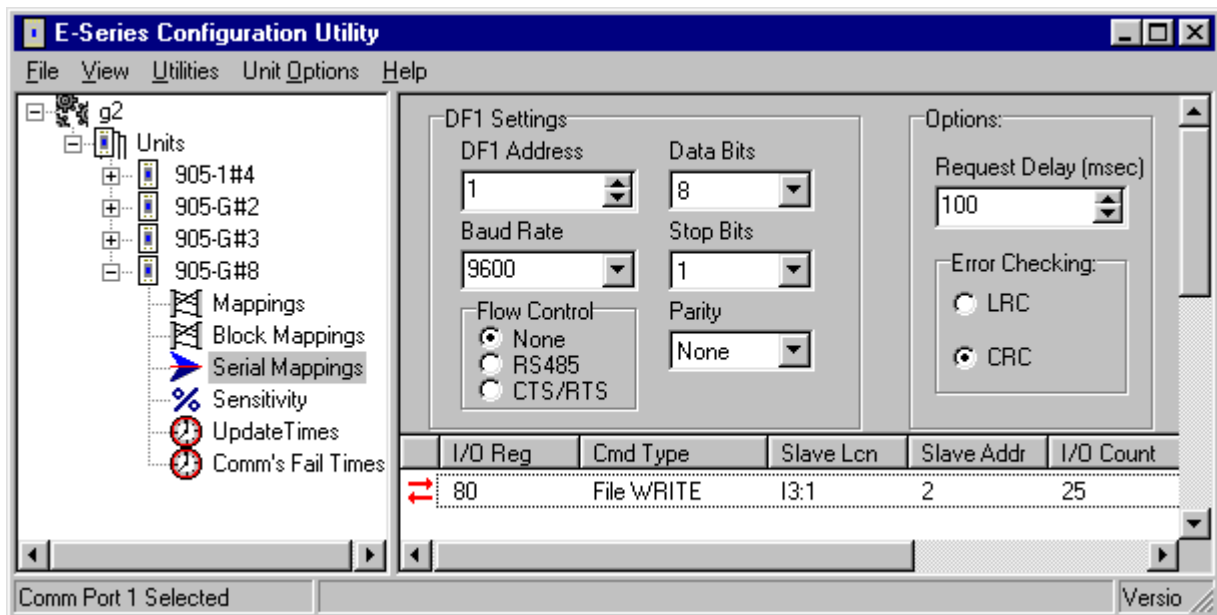

The entry under “I/O Register” (see below) is the first I/O register in the 905G to be transferred - the “I/O count” is the number of registers to be transferred.

The “Command Type” selected is a file write command (you can select read or write) - which means that the values are sent from the 905G to the host device. The type of write command is a “Integer” write, meaning that the register values will be written as register values.

The DF1 address of the host device (or “Slave”) is 2.

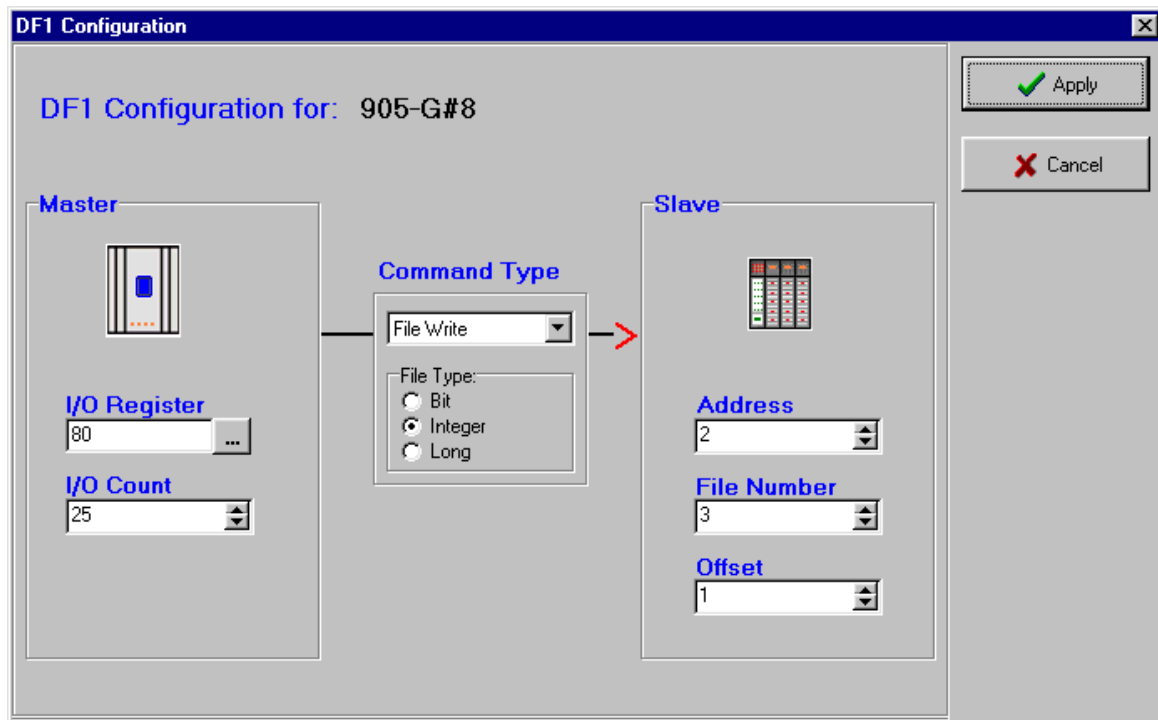

Discrete I/O

The value of a digital I/O point is stored in the 905G database as a hexadecimal '0000' ("off") or hex 'FFFF' ("on"). However the 905G will generate either a '0' ("off") or '1' ("on") to a binary file when initiating a "Typed Logical Write" command or responding to a "Typed Logical Read" command. Similarly, the 905G will accept '0' or '1' from responding device to a "Typed Logical Read" command or from an initiating device generating a "Typed Logical Write" command and store '0000' or 'FFFF' in the database location. The file type for a binary file (bit file) is 0x85.

In the PLC (that is, the DF1 host device), discrete values ("bits") are stored in 16 bit registers - each register stores 16 bit values (or 16 discrete values). You can only transfer these values in groups of 16. That is, a read or write command will transfer a minimum of 16 bits to/from the 905G. If more than 16 are transferred, then they will be transferred in multiples of 16. You cannot transfer an individual bit - you must transfer the 16 bits in that PLC register, which will be transferred to/from 16 consecutive I/O registers in the 905G.

Note: The PLC reads or writes digital bits starting at the LSB of each register. In the 905G, only one bit is written to each I/O register, and this is the MSB.

Analog I/O

Analog I/O from the remote 905U modules are 16 bit register value. A value of 8192 (hex 2000) represents 0mA. A value of 49152 (hex C000) represents 20mA. Each mA has value of 2048 (hex 0800) - a change of 4096 (hex 1000) is equivalent to a change of 2mA. A 4-20mA signal will vary between 16384 (hex 4000) and 49152 (hex C000). A 0-20mA signal will vary between 8192 (hex 2000) and 49152 (hex C000).

Note: If analog values are read to and written from an integer file in an SLC or Micrologix CPU, integer files contain 16 bit *signed* values. These represent values in the range -32768 to 32767. The data values from the 905U modules are treated as 16 bit *unsigned* values. To convert the data from an analog input, move the data from the integer file to a long file (MOV command)

then mask out the high 16 bits (MVM with mask value FFFF). This will result in a long integer value in the range 0 to 65535.

Alternatively, use a long integer file type to transfer the analog value as a long integer in the range 0-65535.

Pulse I/O

Pulse counts from the remote 905U modules are shown as a 16-bit register. When the register rolls over, from 'FFFF' (hex), the next value will be '0001'. The register will only have a value of '0000' when the remote module starts up, and the previous count is lost. This value will indicate that the counter has reset.

Note: The values from the 905G module are 16 bit *unsigned* values. When they are copied to the Integer file in the PLC, they will be treated as 16 bit *signed* values. These values may be converted to the original (unsigned) values using the MOV and MVM instructions described in the previous section (Analog I/O). Again, using a Long Integer type will avoid this problem.

500 CPU (SLC and MicroLogix) file types and addressing

The 905G provides a linear address space of 10,000 data words. This is compatible with PLC2 addresses, but does not match the addressing used by the 500CPU modules (SLC and Micrologic). These address data by file number and file offset. To address an I/O register, L , in the 905G, use DF1 file number $L / 100$, with the remainder value ($L \% 100$) as the DF1 file offset. For example, to read I/O register 2643 in the 905G, read from file number 26, offset 43.

4.8 Fieldbus Configuration

All 905G modules (*except MDI*) have separate internal hardware comprising the Fieldbus Interface, consisting of a separate microprocessor and appropriate hardware for the network connection. This Fieldbus Interface handles all fieldbus communications, and transfers I/O in the Fieldbus Interface Registers to/from the fieldbus. Conversely, the 905G Radio Interface handles all radio communications, and transfers I/O in the Radio Interface Registers to/from the radio network. For I/O transfer between the radio network and the fieldbus network, I/O Registers in the Radio Interface must be linked with registers in the Fieldbus Interface using configuration software.

Depending on the fieldbus protocol, the size of the Fieldbus Interface may be limited (for example, the Profibus Slave interface supports only 416 bytes I/O). The Radio Interface supports 10,000 registers, of which 4300 are general-purpose I/O registers. Each Radio Interface register is 16-bit, even for discrete (or “digital”) input or output values. The Fieldbus Interface comprises a block of 8-bit bytes (referred to as “locations”). Digital I/O can be packed - each fieldbus location can hold 8 digital inputs or outputs. Analog or pulse values can be stored as a low resolution 8-bit value (a single fieldbus location) or as a high resolution 16-bit value (two consecutive fieldbus locations).

To optimize I/O usage, the 905G provides a flexible method of data transfer between the Radio Interface and the Fieldbus Interface. The user configures *links* between the Radio Interface and Fieldbus Interface via *Fieldbus Mappings* in the ESeries Configuration

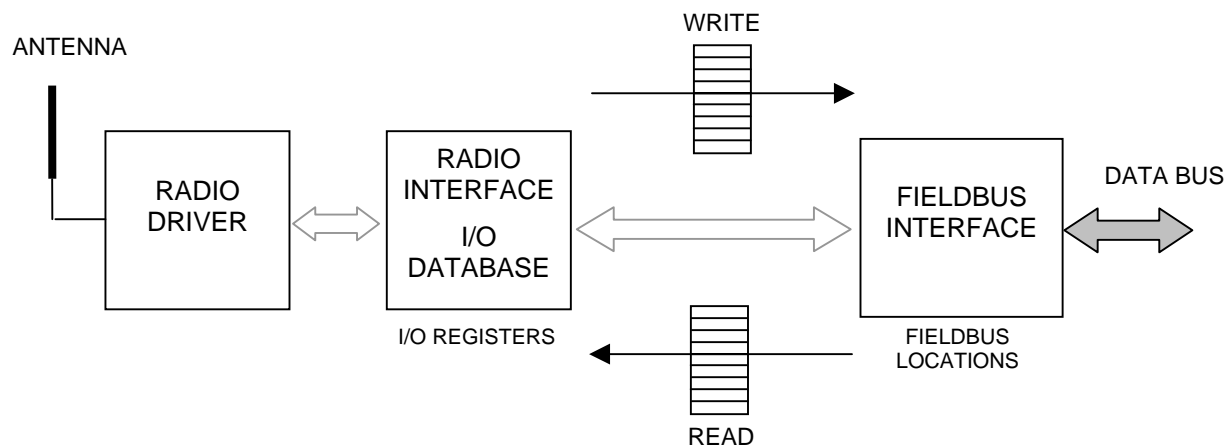

Software. The diagram shows in more detail the relationship between the Radio Interface and Fieldbus Interface.

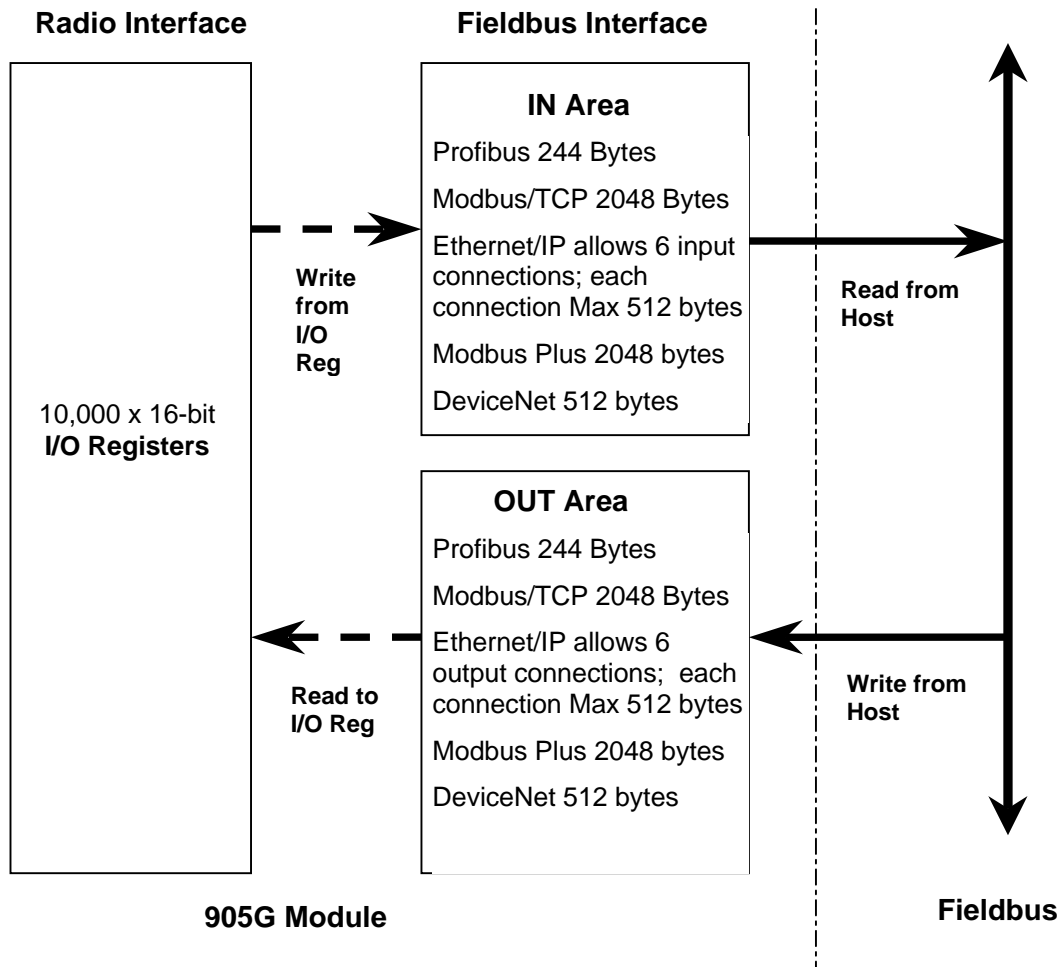

4.8.1 Fieldbus Mappings

The Fieldbus Interface is divided into two distinct areas. The IN Area contains input data that is made available to the host device. The OUT Area contains output data from the host device. This is in contrast to the Radio Interface, in which each 16-bit register can be used as input *or* output. Also note the size of the Fieldbus Interface is variable, depending on the type of fieldbus.

ESeries Configuration Software provides user configurable *Fieldbus Mappings* to link the required Fieldbus I/O to the Radio Interface. *Write* mappings write I/O values from the Radio Interface *to* the Fieldbus IN Area. *Read* mappings read I/O values *from* the Fieldbus OUT Area to the Radio Interface.

If you want to send a value from the 905G to the host device, use a Fieldbus *Write* Mapping. The input data from the Radio Interface (i.e. input data that has either come in from the radio or from local I/O) will be transferred to the IN Area via the fieldbus write mapping. The host device can then read this input data from the IN Area.

If you want to send a value from the host device to the 905G, use a Fieldbus *Read* Mapping. The host device can write output data to the OUT Area. The output data from the OUT Area will then be transferred to the Radio Interface via the fieldbus read mapping. The radio driver can then either send this output over the radio or to a local I/O.

Several different configurable *transfer modes* are also available for fieldbus mappings to ensure the I/O is formatted according to the requirements of the particular fieldbus protocol or host device. The six possible types of Fieldbus Mapping are outlined in the table below.

Fieldbus Mapping Types

<i>Transfer Mode</i>	<i>Read Mapping</i>	<i>Write Mapping</i>
<i>Single Bit</i>	The 905G reads a block of consecutive bits from Fieldbus OUT Area and stores each bit in consecutive I/O Registers, as hex FFFF or 0000.	The 905G takes the MSB (most significant bit) of a block of consecutive I/O Registers, converting the 16 bit I/O register values into 0 or 1, and writes to consecutive bits of Fieldbus IN Area.
<i>Byte (8-bit)</i>	The 905G reads consecutive bytes (8-bit values) from Fieldbus OUT Area and stores each byte in the most significant 8-bits of a consecutive I/O register.	The 905G takes the most significant 8-bits of consecutive I/O registers and writes them to consecutive bytes (8-bit values) of the Fieldbus IN area.
<i>Word (16-bit)</i>	The 905G reads consecutive words (2x8-bit values) from Fieldbus OUT Area and stores each word in a consecutive I/O Register.	The 905G takes consecutive I/O registers and writes them to consecutive words (2x8-bit values) of Fieldbus IN Area.

4.8.2 Transfer Mode

Radio Interface registers are all 16-bit general-purpose input or output registers. That is, analog inputs or outputs are stored as a 16-bit value. Digital inputs or outputs occupy a whole 16-bit register and are stored as either 0000(hex) or FFFF(hex) for compatibility with the ELPRO Radio Protocol. However, the Fieldbus Interface may contain (depending on the protocol) significantly less registers than the Radio Interface (see diagram above). Also, certain protocols may require a different I/O structure than that used by the Radio Interface registers. Consequently, depending on the fieldbus mapping transfer mode (see above table), Radio Interface registers may or may not be compressed.

“Word” transfer mode offers no compression, but rather a direct transfer of 16-bit registers between Radio Interface and Fieldbus Interface. This mode would suit the transfer of registers containing pulse counts or analog values with no loss of resolution.

“Byte” transfer mode operates on only the most significant BYTE (the first 8 bits) of Radio Interface registers, but allows these bytes to be consecutively packed in the Fieldbus Interface. This mode would suit the transfer of analog values in low-resolution, in cases where I/O space is at a premium. *Byte Address Mode* is recommended when using byte transfer mode (see Address Mode section below).

Bit transfer mode operates on only the most significant BIT of Radio Interface registers, but allows these bits to be consecutively packed in the Fieldbus Interface. This mode would suit the transfer of digital I/O in cases where it is not desirable (or possible) to use a whole 16-bit register just to store a 0 or 1 value.

4.8.3 Address Mode

Configuration software allows the Fieldbus Interface IN and OUT areas to be addressed as an array of 8-bit bytes (*Byte Address Mode*) or an array of 16-bit words (*Word Address Mode*). The address mode may be required to change depending on the transfer mode, the protocol, or the particular host device. The Address Mode option is included so that the configuration software can be setup to use the same I/O addressing method used by the host device. The actual structure of I/O in this database can only be physically altered via the transfer mode.

The Fieldbus Interface IN and OUT areas are simply a block of I/O memory, exchanged according to the configured protocol. For example, with a Profibus slave that supports 244 bytes of inputs, the fieldbus interface IN area could be addressed either as byte locations 1 to 244 or as word locations 1 to 122. Note that in either case, the underlying database structure is unchanged, the difference is limited to the Fieldbus IN/OUT Area address that is displayed by configuration software.

Certain protocols have an inherent or preferred byte or word structure – for example, Modbus is a protocol that usually operates on 16-bit (word) registers. Consequently, configuration software will default to the most common address mode for that protocol. Configuration software may also apply an offset and/or scaling to the IN/OUT Area addressing to suit the particular protocol. For example Modbus/TCP areas start from location 1, but other fieldbuses may start at location 0.

Note:

- The Fieldbus Interface IN *and* OUT Area both number from 0 - that is, there is an input 0 as well as an output 0 (an offset may apply for some protocols).
- All IN/OUT Area locations accessed by the fieldbus must be part of a fieldbus mapping in the 905G - that is, if a host device is writing to bytes 0 – 100 in the OUT Area, there must be at least one fieldbus read mapping that uses these locations - if not, the Fieldbus Interface will generate an error response message.
- Fieldbus mappings to/from the IN/OUT areas should always start at location 0 if possible (or the lowest available unused location). Configuration Software will always automatically choose the next lowest available location – it is strongly recommended that this topology be used so as not to place unnecessary processing overhead on the module.

4.8.4 Fieldbus Mapping Configuration

The example below shows the Fieldbus Mapping configuration screen when adding new or editing existing Fieldbus Mappings. Starting from the left of the screen, the I/O Register selection specifies the starting I/O Register from the Radio Interface (press the “...” button to make a selection graphically). The I/O Count parameter specifies how many consecutive I/O Registers are to be transferred or *linked*. Command Type and Transfer Mode specify the type of Fieldbus Mapping (see Fieldbus Mappings table above). Finally, I/O Location specifies the IN or OUT Area location in the Fieldbus Interface (see earlier diagram).

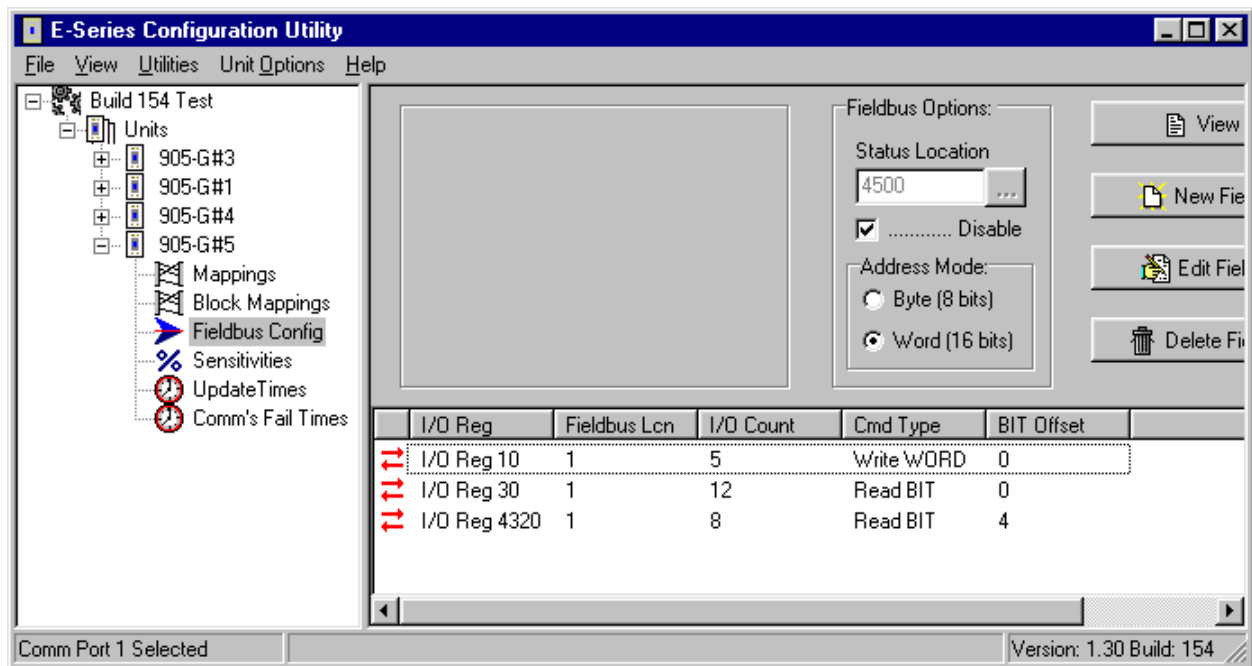
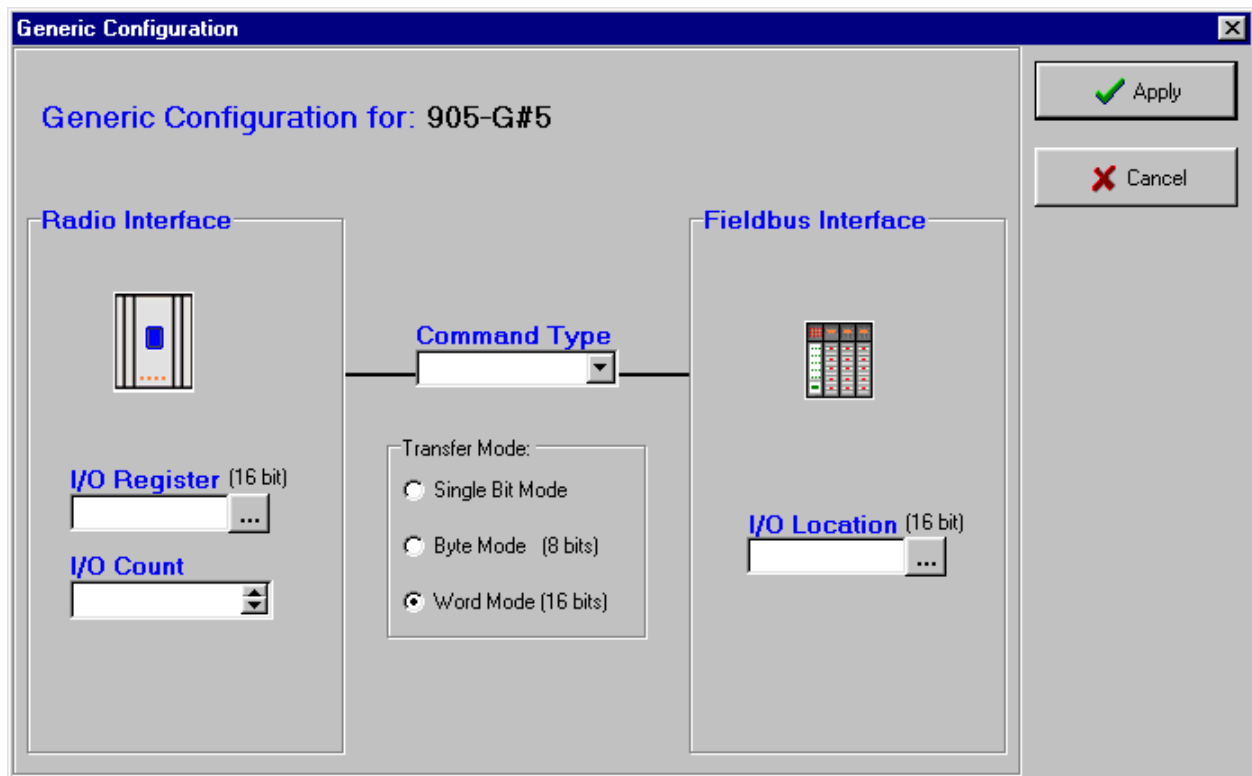

Three Fieldbus Mappings are illustrated in the example above. Note that “Word Address Mode” is selected, meaning that the Fieldbus Interface IN and OUT Areas will be treated as word-addressed arrays by configuration software. The parameters for each fieldbus mapping were setup using the mapping configuration screen as described above.

The first Fieldbus Mapping is a “Write WORD” mapping, writing I/O Registers 10 – 15 from the Radio Interface to word-locations 1 – 5 in the Fieldbus IN Area. Because the *transfer mode* is “word” complete 16-bit registers are transferred.

The second mapping is a “Read BIT” mapping, reading 12 *bits* from Fieldbus OUT Area *word-location* 1 (word address mode is selected) to I/O Registers 30 – 41. Remember that for such a BIT transfer, that each individual bit in the Fieldbus Interface is transferred to an entire 16-bit I/O Register. Note also that there is a word-location 1 for both the Fieldbus OUT *and* IN areas.

The third mapping is another “Read BIT” mapping, reading 8 bits from Fieldbus OUT Area word-location 1 to I/O Registers 4320 – 4327 (i.e. local DOT 1 – 8). Note here that we are again reading from Fieldbus OUT Area word-location 1 (as with the previous mapping). However, since each word-location contains 16-bits and the last mapping used only 12 of

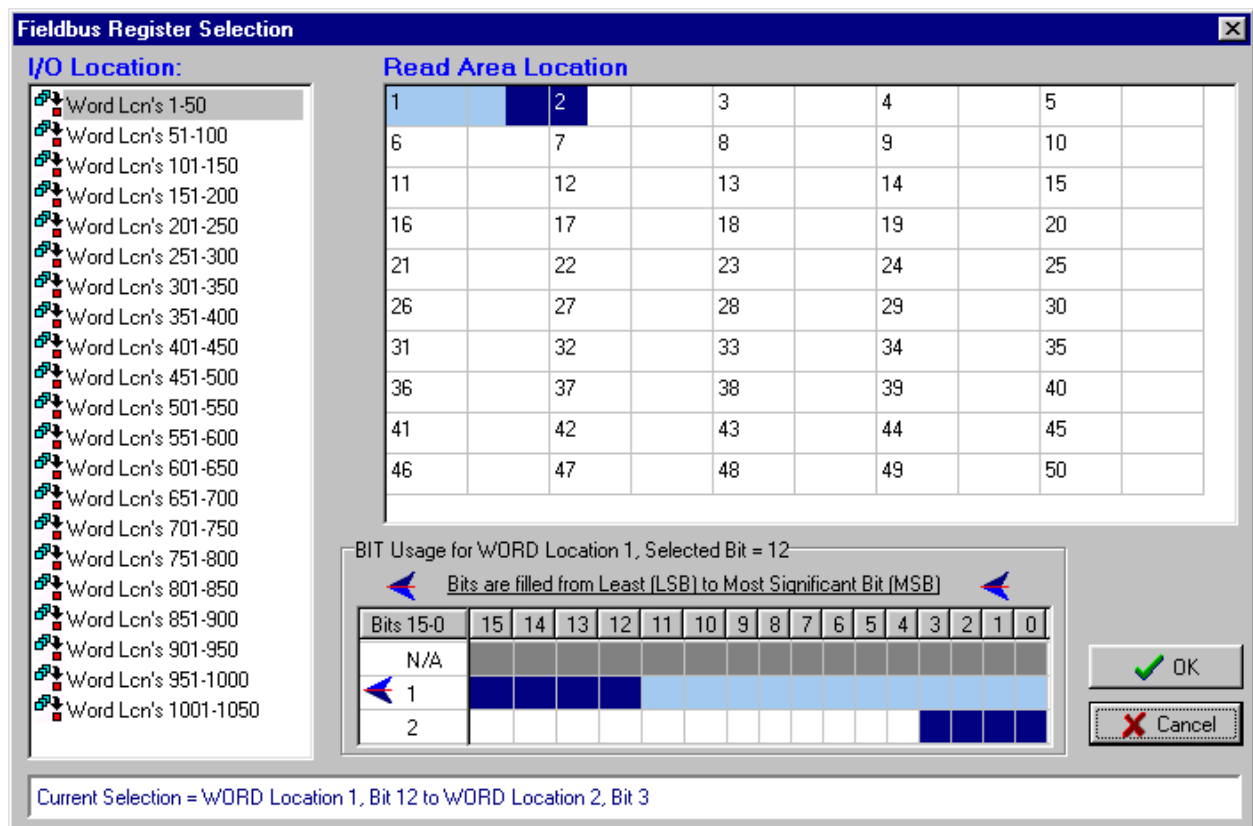

those, we have been able to follow on from the previous mapping (see below).

The Fieldbus Register Selection screen above was shown when selecting the Fieldbus OUT Area location for the third mapping in the above example. This screen shows the currently used portion of the Fieldbus OUT Area, and allows the user to graphically select the location for the current mapping. NOTE – by default configuration software will always choose the next available Fieldbus Interface register for fieldbus mappings. Allowing configuration software to automatically make the selection is strongly recommended wherever possible.

Clicking on the required location in the top panel will alter the currently selected word-location. Further, clicking individual bits in the “Bit Usage” panel at the bottom of the screen, allows the current BIT mapping to be specified at the bit-level of the currently selected word.

The lighter blue areas indicate the extent of already existing fieldbus mappings. It can be seen that bits 0 – 11 of word location 1 have already been used (by the second mapping in the

example). The dark blue area in the register selection screen above shows the extent and location of the current fieldbus mapping graphically. The status panel at the bottom of the window always displays the extent of the current selection, which can be seen to be word 1, bit 12 to word 2, bit 3.

A status location (4500) may be used to give the host device status information about the Fieldbus Interface. This register will be value 0x0000 if the Fieldbus Interface is “on-line” and communicating with the fieldbus, or value 0xFFFF if it is “off-line”. If you wish to use a status register, select the “Enable Status Location” box. This register could be mapped to a remote module or local output as an alarm.

4.9 Fieldbus Configuration - Profibus Slave

The Profibus 905U-G-PR1 acts as a Profibus DP Slave - the host device is a Profibus Master. If you use the 905U-G with a PLC, the PLC configuration tool will require a GSD file so it can recognize the Profibus interface in the 905U-G. This file loads into the PLC configuration software (for example, Siemens STEP 7). The file is available on the same CD as the configuration software or from the Elpro web page www.elprotech.com.

Configuration of the Profibus Fieldbus Interface comprises allocating a Profibus Slave address to the 905G, and configuring links between the Radio Interface and the Fieldbus Interface (i.e. Fieldbus Mappings).

The Profibus address can be set in the “Fieldbus Config” screen or via the rotary switch on the end-plate of the module- valid slave addresses are 1 – 126. If the “Enable Rotary Switch” box is not selected, then the address entered in the program will be used and the rotary switch value ignored. If the “Enable Rotary Switch” box is selected, then the address entered in the configuration program will be ignored and the rotary switch read on start-up of the 905G.

The Profibus interface has 416 bytes, of which 244 can be used as input bytes, or 244 can be used as output bytes.

Note: For bit transfers, the bit offset is counted from the least significant bit (LSB) of the byte (with bit 0 being the LSB) - if you transfer 3 bits with a bit offset of 5, then you will transfer bits 5-7 of the byte. This is different than the Ethernet unit which counts the offset from the most significant bit - refer next section.

An application note for configuring a Siemens S7 PLC to communicate with a Profibus 905G can be downloaded from the Elpro web-site www.elprotech.com

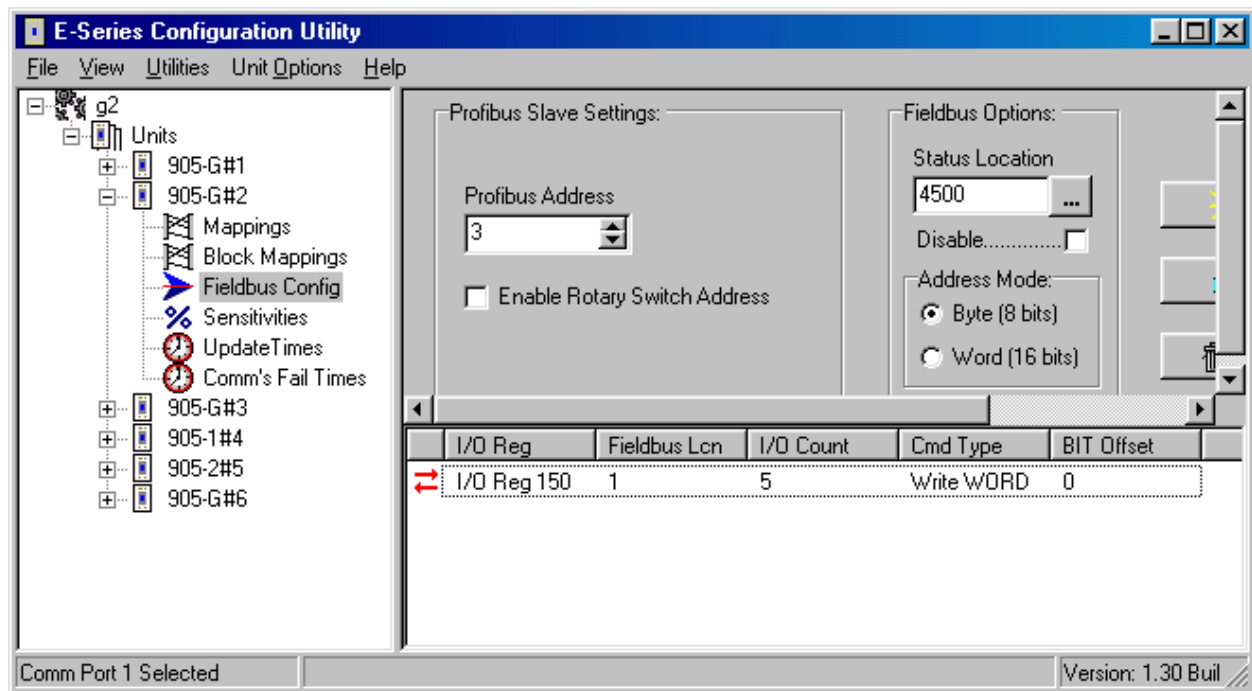

4.10 Fieldbus Configuration - Profibus Master

The 905U-G-PR2 implements a complete Profibus-DPV0/DPV1 master. The hardware is optimized for high throughput and can be used in mono or multi master networks up to 12 Mbit/s. Up to 125 slaves with a total max of 2048 byte input and 2048 byte output data can be connected.

4.10.1 GSD File

Each device in a Profibus network is associated with a GSD file, containing all necessary information about the device. In general, the profibus slave device manufacturer supplies the relevant GSD files. ESeries Configuration Software uses these files during network configuration.

4.10.2 Protocol and Supported Functions

The 905U-G-PR2 implements a complete Profibus-DPV0/DPV1 master and includes the following features:

- Up to 125 slaves can be connected
- Up to 2048 bytes input & output data
- Up to 12 Mbit/s on Profibus
- RS-485 optically isolated Profibus interface with on-board DC/DC converter
- Configuration via ESeries Configuration Software
- Acyclic Communication (DPV1)
- Alarm Handling (DPV1)

4.10.3 Configuration

Profibus network configuration is performed via the ESeries Configuration Utility. The 905G Profibus Master provides up to 2048 bytes of inputs and 2048 bytes of outputs in the fieldbus interface for I/O on the profibus network. I/O in the fieldbus interface must be linked with I/O in the radio interface via appropriate *fieldbus mappings* (see 4.8 *Fieldbus Configuration* above) for I/O transfer with the radio network.

Configuration of the profibus network is through the *Profibus Network Config* tab in ESeries Configuration Software. Through this section, the entire (local) profibus network including I/O data transfer with profibus slaves is configured. Before a profibus slave is configured on the network, its corresponding GSD file must be installed. To install a GSD file choose *File/Install GSD File*. Once the GSD file(s) have been installed, the devices corresponding to those GSD files will appear as devices on the Profibus DP *treeview* on the left side of the network configuration screen.

The profibus network configuration screen is divided into three main areas (see below). The left hand *Profibus DP Treeview* displays all the available slaves, i.e. those whose corresponding GSD files have been installed. The right hand top section *Busview* displays graphically the devices that are currently configured on the profibus network – individual devices can be selected here and their I/O configuration and other properties viewed/alterd. The right hand bottom section *Listview* shows the I/O configuration of a particular slave when a slave device is selected in the busview, or the network configuration (i.e. what slaves are configured and their corresponding addresses) when the profibus master node is selected in the busview.

Bus Address	Type	Name	Vendor	Comment
0	Master	105-G	ELPRO Technologies	
1	Slave	DP/RS232C Link	SIEMENS AG	
2	Slave	07 KT 97-DPS	ABB STOTZ-KONTAKT G...	
3	Slave	CPU 314-2C DP	SIEMENS	
4				
5				
6				
7				
8		GSD Example E12		
9				
10				
++				

Adding a Slave to the Network

To add a profibus slave to the network, locate the required slave and simply drag the slave icon onto the visible bus cable on the busview, or right click the required slave and choose *add to network*. To add a slave with a specific profibus node address to the network, locate the required slave and drag the icon to the network listview (ensure that the master node is

selected in the busview so that the network list is displayed in the listview rather than the slave I/O configuration list). The above example shows a slave device being added to the network at node address 7.

Slave Address

To change the node address of a slave already configured on the network, locate the slave in the network listview and drag it to the position in the list corresponding to the desired address. Alternately, the slave address can be modified from the *module properties* page (see below).

Module Properties (Slave)

To display the properties of a given slave, right click the required slave in the busview and choose *properties* (or double click the icon in the busview). Under the *general* tab, various details (including GSD file details) relating to the selected slave device are displayed. Several configurable options are also available (see below).

Profibus Address

The actual profibus address of the selected slave is shown in the address selection box. Only available addresses are listed and can be selected as new address.

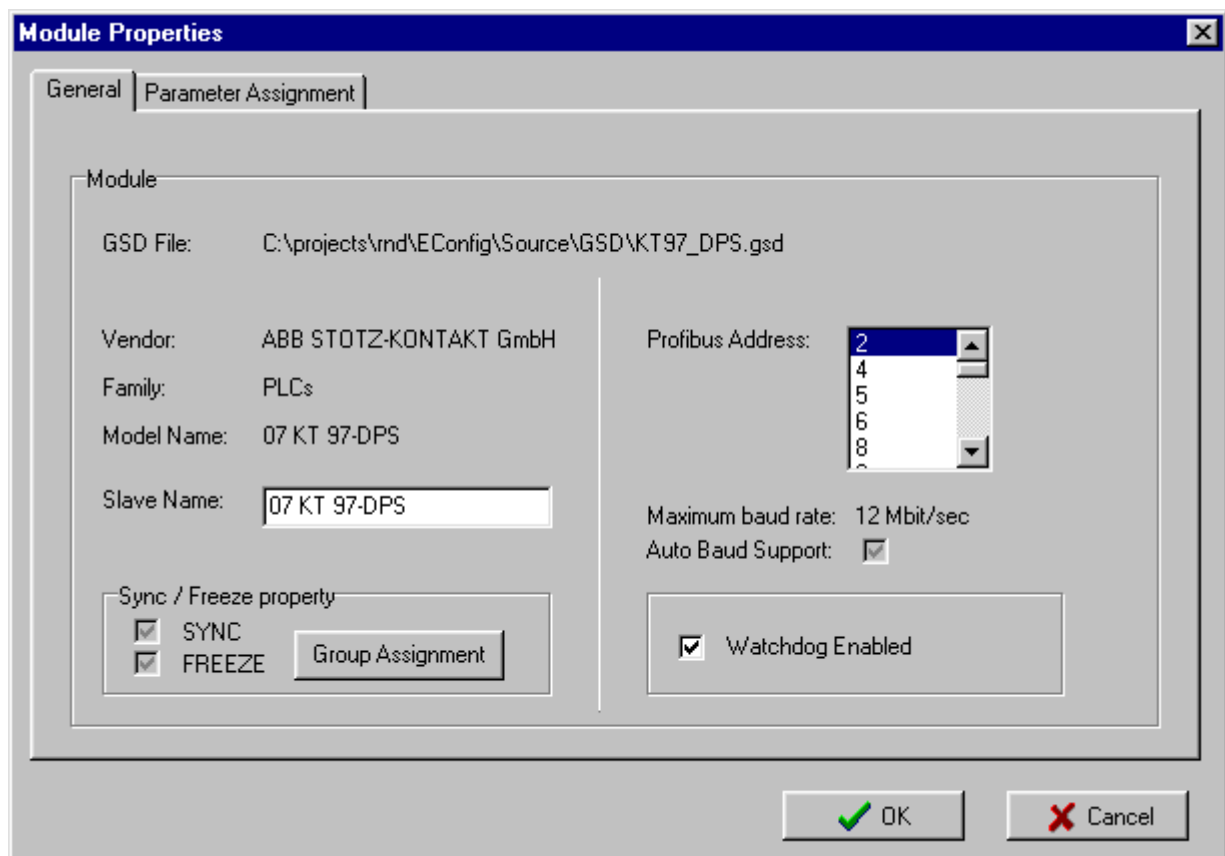

Watchdog

According to the profibus specification, a slave device may be configured with a watchdog function such that the master must poll the slave within a defined interval. If this feature is enabled and the master fails, the slaves watchdog timer will timeout and the slave will reset itself.

Group Assignment

If the slave supports sync/freeze functionality, it can be assigned to the masters sync/freeze groups by clicking on the checkboxes. The sync/freeze assignment of the groups is also displayed (these can be changed via the master properties dialog).

Group	1	2	3	4	5	6	7	8
SYNC	<input checked="" type="checkbox"/>	<input type="checkbox"/>	<input checked="" type="checkbox"/>	<input type="checkbox"/>	<input type="checkbox"/>	<input type="checkbox"/>	<input type="checkbox"/>	<input type="checkbox"/>
FREEZE	<input checked="" type="checkbox"/>	<input checked="" type="checkbox"/>	<input type="checkbox"/>	<input type="checkbox"/>	<input type="checkbox"/>	<input type="checkbox"/>	<input type="checkbox"/>	<input type="checkbox"/>
07 KT 97-DPS	<input checked="" type="checkbox"/>	<input checked="" type="checkbox"/>	<input type="checkbox"/>	<input type="checkbox"/>	<input type="checkbox"/>	<input type="checkbox"/>	<input type="checkbox"/>	<input type="checkbox"/>

SYNC FREEZE

OK Cancel

Parameter Assignment

Parameter	Value
Switch 1	OFF
Switch 2	OFF
Switch 3	ON
Switch 4	OFF
Switch 5	OFF
Switch 6	OFF
Switch 7	OFF
Switch 8	OFF
Byte	0
Byte	0
Integer	0
Integer	0

Hexadecimal Parameter Assignment									
User_Prm_Data 0 - 7	00	00	00	00	00	00	00	00	00
User_Prm_Data 8 - 9	00	00							

OK Cancel

A slaves user-specific parameters can be changed via the *parameter assignment* page. User-specific parameters for a slave device are defined in the corresponding GSD file for the device, the definition of which are device-specific and should be found in the documentation for the device.

Parameters can be altered via combo boxes or via direct input of hexadecimal values. The hexadecimal values for the user_prm_data are displayed at the bottom of the screen and can

be edited directly (consult the device specific documentation for the meaning of these values).

Adding I/O to a Slave

The possible I/O combinations for a given slave may be fixed or configurable (i.e. modular) depending on the GSD file for the device. When the I/O configuration is fixed, the fixed I/O are always defined whenever the device is added to the network. However, for modular devices, the I/O configuration must be assigned manually.

The GSD file for a modular slave will define a maximum number of I/O *slots* – each of which may be configured with an I/O *module*. The available I/O module's for a particular slave can be viewed by expanding the slave node in the Profibus DP Treeview. To add an I/O module to a slave, first ensure the required slave is selected in the busview, then drag the required I/O module into a spare slot of the slave listview.

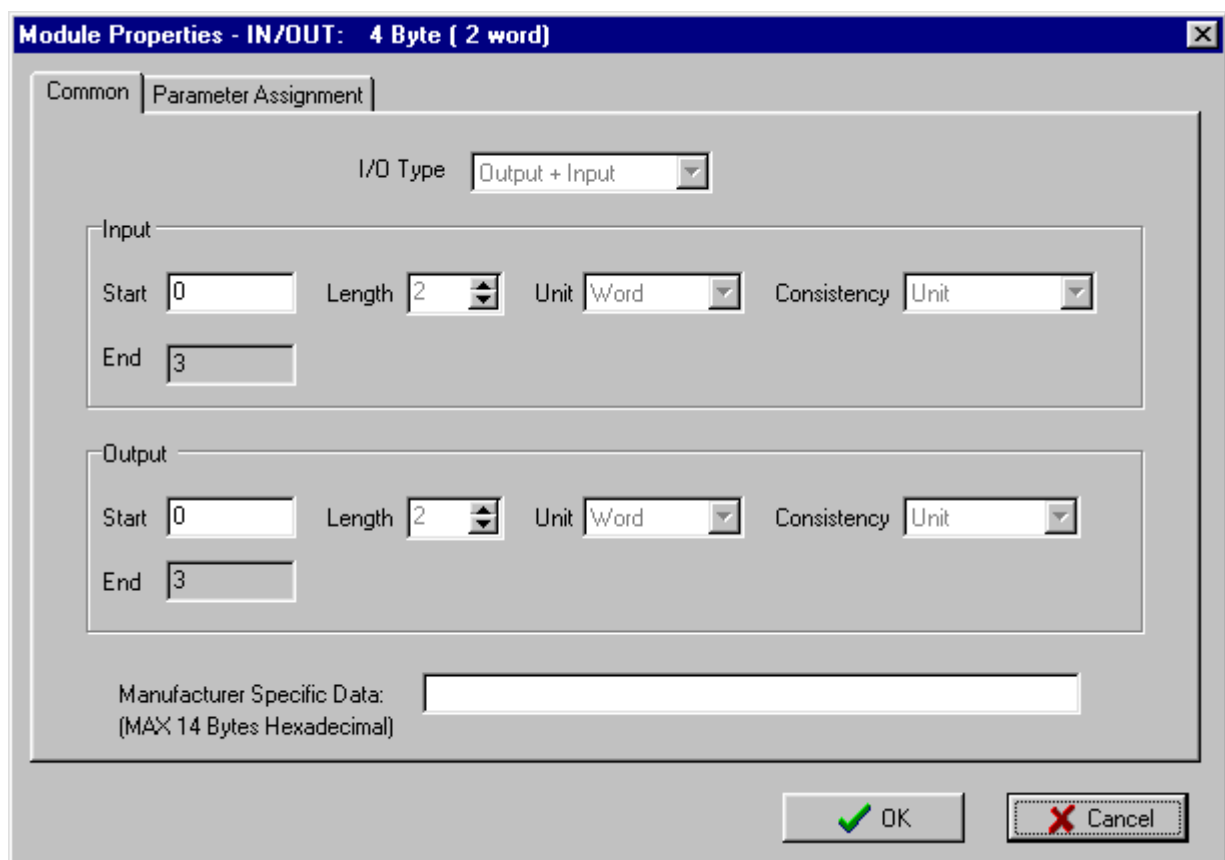

When an I/O module is added to a slave, configuration software will automatically assign that I/O to the next available space in the fieldbus interface. The input and output addresses that are assigned here will correspond to the locations that must be transferred via fieldbus mappings in order to make the I/O available to the radio network. The input and/or output address assigned by software for a given I/O module can be altered by double clicking on that I/O module entry in the slave listview (see above).

The start address in the fieldbus interface for the inputs or outputs can be altered in the corresponding *Start* field as shown above. Since the 905G provides for up to 2048 bytes of inputs and 2048 bytes of outputs, the possible range for inputs or outputs is 0 – 2047.

I/O modules may also have associated user parameter data defined by the corresponding GSD file. The meaning of these parameters (if applicable) is specific to the slave implementation, and may be altered via the *Parameter Assignment* tab of the *Module Properties* form.

Configuration software also provides an additional I/O module to all slaves that is *not* defined in the GSD files, which is the *Universal Module*. The universal module allows the input/output length, unit, and consistency to be assigned custom values as required – however not all slave implementations will support this feature (consult the specific slave documentation for details).

The *Length* parameter defines the length of the input or output module in either bytes or words (according to the corresponding *Unit* parameter). The data *consistency* over the profibus network may be applied to the selected unit (i.e. byte or word) or to the total length of the input or output selection.

Depending on the particular slave, *Manufacturer Specific Data* may also apply to an I/O module. This data is a string of hexadecimal bytes, the meanings of which (if applicable) are device specific and should be detailed in the documentation for the particular device.

Master Properties

The profibus master 905G has some configurable properties that affect the entire profibus network. These properties can be accessed by double clicking the master icon in the network busview, or right-clicking the icon and choosing *properties*.

Profibus Tab

The *Address* parameter specifies the actual profibus address of the profibus master (default = 0). Only available addresses are listed and can be selected as new address. The serial *baud rate* for the entire profibus network is selected – this is the baud rate that will be used by the master and therefore must also be supported by all slave devices on the network. Most slaves will support auto baud rate detect, but it should be ensured that any slave on the network supports the configured baud rate.

The *Profile* parameter controls the assignment of *Bus Parameters* for the profibus network.

In the single master (default) profile, the bus parameters are calculated automatically by configuration software and are optimised for speed – no other masters may be connected to the network. The *User Defined* profile allows the bus parameters to be manually configured for special network configurations and should only be used if the user is familiar with the individual profibus

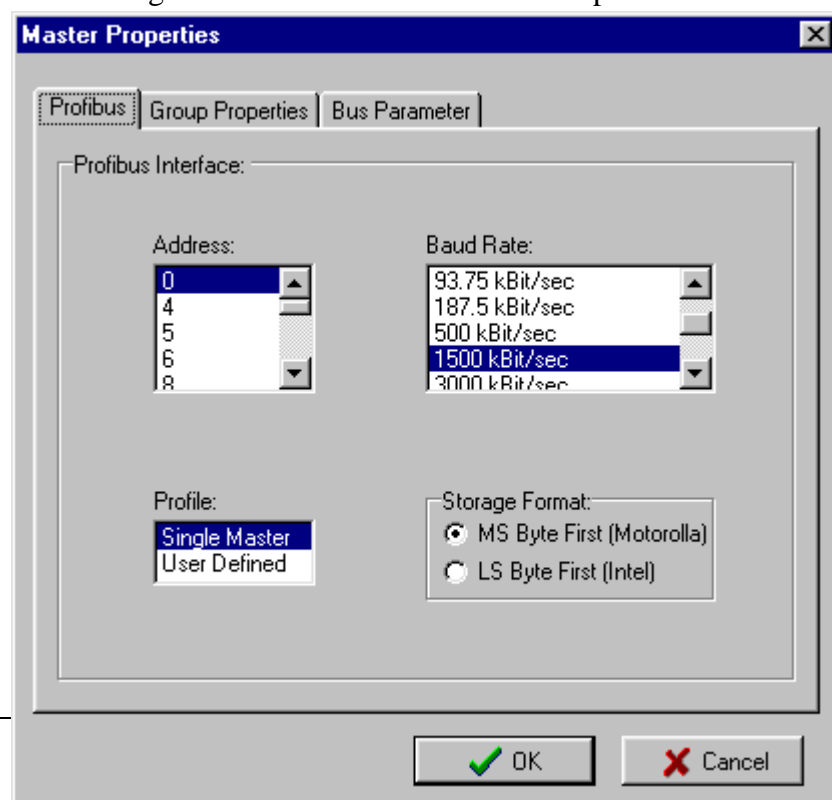

parameters (see *Bus Parameters Tab* below).

The storage format determines if word values are stored in big endian (Motorola – most significant byte has lowest address) or little endian (Intel – Least significant byte has lowest address) format.

Group Properties Tab

A DP master can send the SYNC and/or FREEZE control commands simultaneously to a group of slaves for synchronization purposes. Therefore the slaves must be assigned to Sync/Freeze - groups. Up to 8 groups may be configured as SYNC and/or FREEZE groups. Any slaves that are configured to belong to a particular group (via that slaves *module properties/group assignment* configuration) may be synchronized using the *Message Interface* instruction *SET_SLAVE_MODE* (see section on the *Message Interface* below).

Bus Parameters Tab

The bus parameters can be adjusted only when the selected profile is *user defined* (see *Profibus Tab* above). These parameters should only be changed if the user is familiar with the individual profibus parameters according to the profibus specification.

Adjustable bus parameters:

Tslot

The slot time determines the maximum length of time the sender has to wait to receive a response from the partner.

$$\text{Max. Tsdr} + 15 \leq \mathbf{Tslot} \leq 16.383 \text{ t_bit}$$

Max Tsdr

The maximum station delay responder determines the maximum length of time required by the responding node to respond

$$35 + 2 * Tset + Tqui \leq \mathbf{Max. Tsdr} \leq 1.023 \text{ t_bit}$$

Min Tsdr

The minimum station delay responder determines the minimum length of time permitted for the responding node to respond.

$$11 \text{ t_bit} \leq \mathbf{Min. Tsdr} \leq \text{Max. Tsdr} - 1$$

Tset

The setup time determines the length of time elapsing in the node between a data frame being received and a response occurring

$$1 \text{ t_bit} \leq \mathbf{Tset} \leq 494 \text{ t_bit}$$

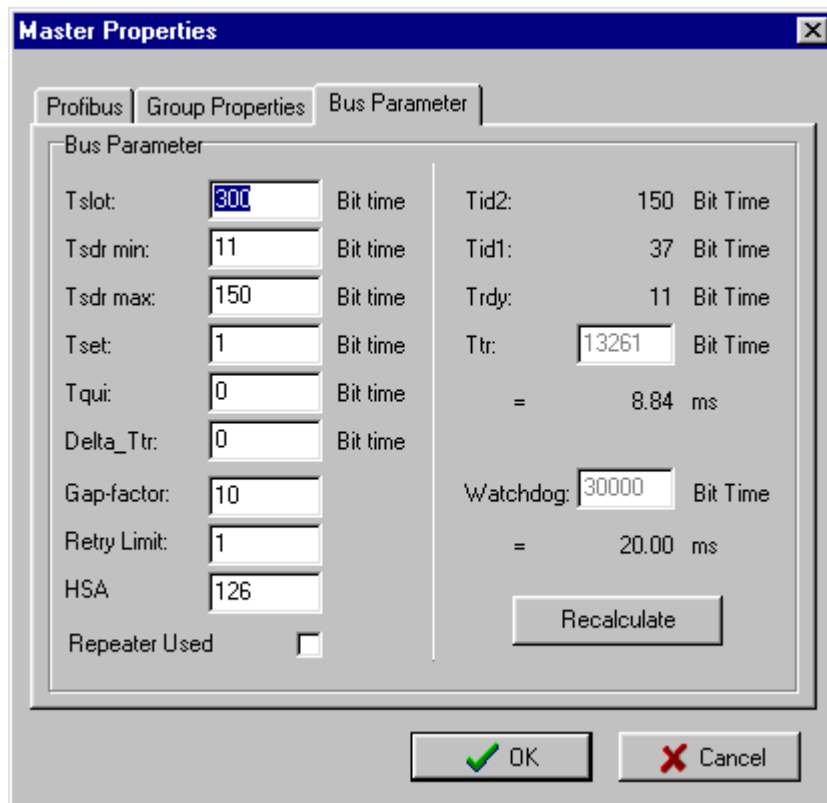

Tqui

The quiet time is the time a modulator needs after recognizing a send frame to switch from send to receive.

$$0 \text{ t_bit} \leq \mathbf{Tqui} \leq \text{MIN}(31 \text{ t_bit}, \text{Min. Tsdr} - 1)$$

Gap Factor

The Gap Factor determines how many token rounds occur before a new active node (master) can be added to the token ring.

$$1 \leq \mathbf{Gap Factor} \leq 100$$

Retry Limit

The Retry Limits determines the number of attempts (repeated message frames) allowed to access a node.

$$1 \leq \mathbf{Retry Limit} \leq 15$$

HSA

All active nodes (masters) scan the network continuously up to the HSA (highest station address). HSA must be set at minimum to the highest profibus address (master or slave) connected to the network.

$$0 \leq \mathbf{HSA} \leq 126$$

Delta_Ttr

This value can be set for multi master networks with the selected profile *Multi Master*. Delta Ttr is added to the calculated Ttr to increase the Ttr for using multiple masters in a network.

$$256 t_{\text{bit}} \leq T_{\text{tr}} \leq 16.776.960 t_{\text{bit}}$$

Non-adjustable bus parameters

Ttr

The target rotation time determines the maximum available time for a token pass. During this time all active nodes (masters) obtain the token one time to send data. ESeries Config Software calculates an optimized Ttr depending on the values of other bus parameters. If an individual bus parameter is changed, pressing the Recalculate-button recalculates the **Ttr** including **Delta_Ttr**.

Watchdog

The watchdog determines the watchdog time transferred to slaves if the watchdog is enabled.

Tid2

The idle time 2 determines the maximum length required before a transmitting node can send the next message after sending a message frame that is not acknowledged.

$$T_{\text{id2}} = \text{Max. } T_{\text{sdr}}$$

Tid1

The idle time 1 determines the minimum length required before a transmitting node can send the next message after sending a message frame that is not acknowledged.

$$T_{\text{id1}} = 35 + 2 * T_{\text{set}} + T_{\text{qui}}$$

Trdy

The ready time determines the minimum time for a transmitting node to receive a response message frame.

$$T_{\text{rdy}} = \text{Min. } T_{\text{sdr}}$$

Configuration Example:

The Following example describes a simple configuration of a 905G connected to a simple Profibus Slave I/O device. Described is the configuration of the local 905G Profibus master only, for more detailed configuration examples, an application note can be downloaded from www.elprotech.com.

The example will transfer 8 x digital points from the radio network *to* the slave device. A single 16-bit analog value will be transferred from the profibus slave to the radio network. Several configuration steps via ESeries Configuration Software are required:

- Profibus Network Configuration
- Fieldbus Configuration (Fieldbus Mappings)
- Radio Configuration (I/O or Block Mappings)

1) Profibus Network Configuration

Once the GSD file for the profibus slave has been installed, the slave device can be added to the profibus network (see *Configuration* section above). For this example, the slave is a *modular* device, therefore we add the necessary I/O modules to the slave. The example requires 8 x digital points to be transferred *to* the slave - hence we add the '1 Byte Out' module - and 1 x analog point (16-bit) to be transferred *from* the slave – hence we add the '2 Byte In' module (see below).

Slot	CFG Data	Order No./Designation	Input Address	Output Address
0	0x20	Module 1 Byte Out		0
1	0x11	Module 2 Byte In	0..1	

When these modules are added, configuration software automatically picks the next free *fieldbus interface* registers (shown in the *Input Address* and *Output Address* columns), which may later be altered by double-clicking on the relevant I/O module. In this example, the automatically chosen locations are *Fieldbus IN* locations 0..1, and *Fieldbus OUT* location 0.

2) Fieldbus Configuration.

The next configuration step is to transfer the I/O in the *Fieldbus Interface* to the *Radio Interface* so that the profibus I/O is available to the radio network. The 8 x digital output to be sent to the profibus slave are transferred using a *fieldbus write mapping*. Since the 8 x digital outputs are all contained in a '1 Byte Out' module, we use 'Single Bit Mode' for the fieldbus write mapping. The configured mapping (see below) transfers the 8 x I/O Registers 100..107 in the radio interface to single bits in Fieldbus Location 0 of the fieldbus interface (corresponding to the Output Address of the corresponding '1 Byte Out' module).

The 1 x analog input to be read from the slave must now be transferred to the radio interface. Here we use a fieldbus read mapping using a 'Word Mode' (16-bit) transfer from Fieldbus Locations 0..1 to I/O Register 200.

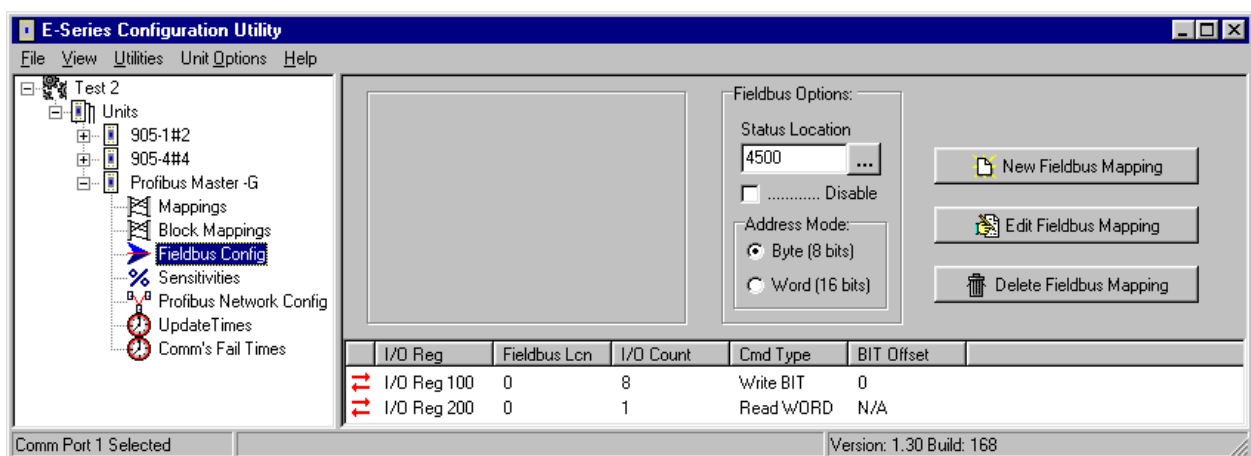
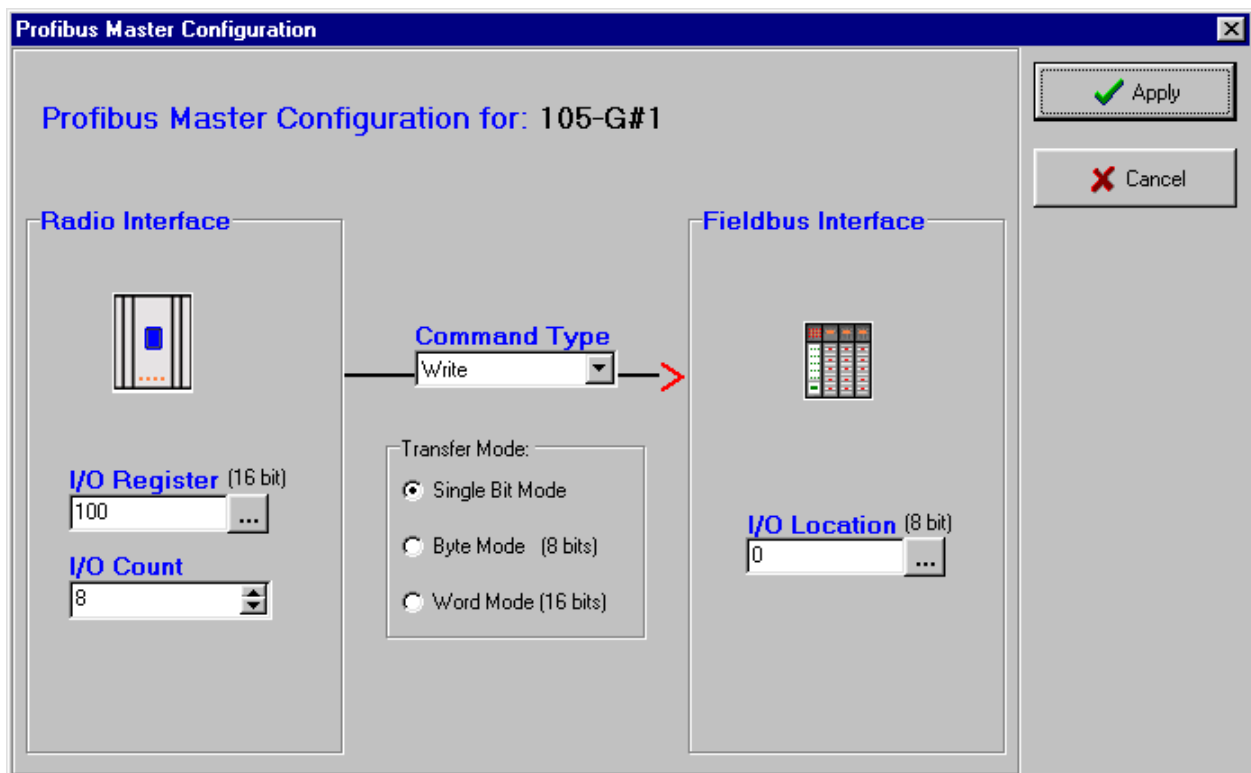

3) Radio Configuration

To complete the configuration, the I/O that has now been transferred to the radio interface must be mapped over the radio network. The analog input from the slave is mapped to an analog output at a remote 905U-1, the 8 x digital output at the profibus slave will be activated in this example via appropriate mapping from 8 x digital input at a remote 905U-4 (see below).

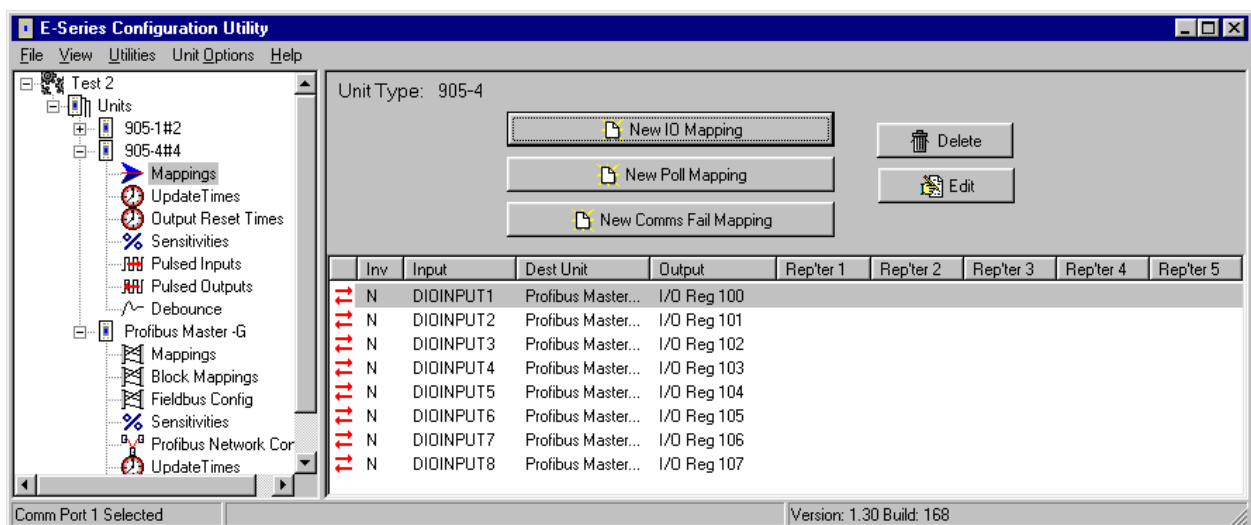
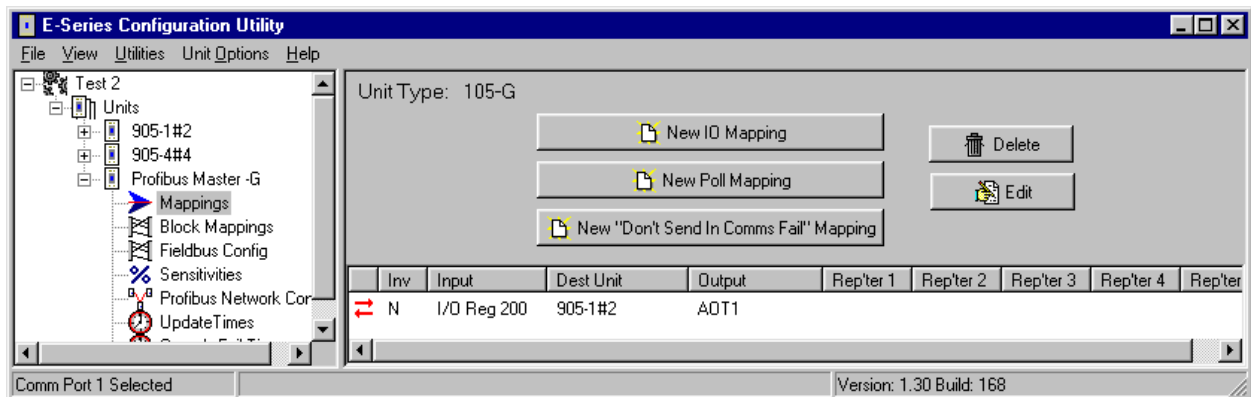

4.10.4 Message Interface

In addition to cyclic data exchange with slave devices, the 905G Profibus Master also supports a number of acyclic services that may be triggered via a special *Message Interface*. The message interface is by default disabled, but will become enabled by also enabling a “Status Location” via the *fieldbus configuration* tab in configuration software.

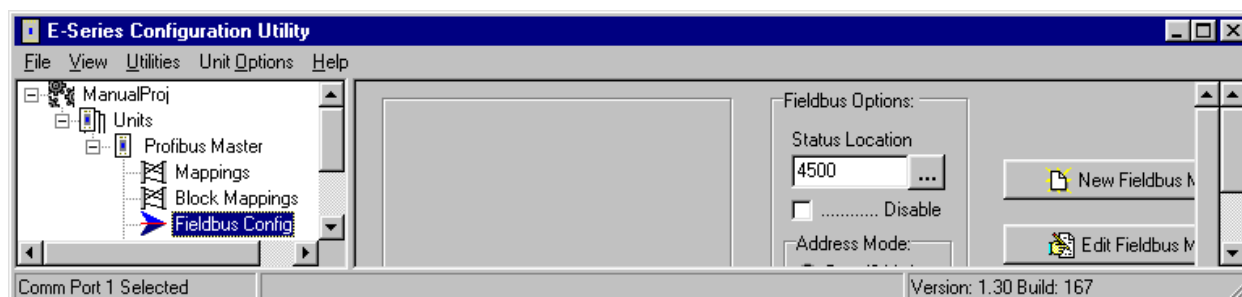

The message interface is used to instruct the 905G to perform a specific task, to request data, to indicate certain events (alarms), or to respond to requests. The message interface can be controlled via a host or other smart device by constructing the appropriate message in the Message Interface Area of the 905G I/O Registers (radio interface). Since the message interface is part of the radio interface, it may be controlled either remotely via appropriate block mappings (i.e. remote 905G), or locally via a device on the profibus network (i.e. configuration tool, PLC, or other smart device).

The supported messages are listed in the table below.

Message	Description
SET_SLAVE_MODE	Send control command to slave(s) (Sync/Freeze)
GET_SLAVE_DIAG	Get diagnostic information from a slave
GET_SLAVE_CONFIG	Get slave configuration
SET_SLAVE_ADDRESS	Set node address of a slave (If supported by slave)
MSAC1_READ	acyclic read (class 1)
MSAC1_WRITE	acyclic write (class 1)
GET_LIVE_LIST	Get information from all nodes on the network
MSAC1_PROFIDRIVE_V3_PARAM_WRITE	PROFIdrive v.3 acyclic parameter access
MSAL1_ALARM_IND	Alarm indication from DPV1 slave
MSAL1_ALARM_CON	Confirmation to FB_MSAL1_ALARM_IND

The message interface supports the following types of communication:

- **Command - Response**

A message is sent by the message initiator, and the message recipient is required to respond. The message initiator can be either the 905G or host device.

- **Indication**

A message is sent by the message initiator, and no response is required. The message initiator can be either the 905G or host device.

Message Structure

A message consists of a message header and message data (see table below). The header consists of a series of 16-bit registers that specifies the type of message and the length of the message data. The message data may be up to 128 x 16bit registers in length and contain data that is specific to the particular message.

Offset:	Register:	
0	Message ID	}
1	Message Information	
2	Command Number	
3	Data Size	
4	Extended Word 1	
5	Extended Word 2	
6	Extended Word 3	
7	Extended Word 4	
8	Extended Word 5	
9	Extended Word 6	
10	Extended Word 7	
11	Extended Word 8	}
12	Message Data	
:::	(up to	
139	256 Bytes)	

Message ID

The Message ID register contains a 16-bit integer identifier for the command. When a response is sent back to the message initiator, the same message ID is used in that message. Message ID's can be selected arbitrarily, but successive messages must contain different ID's so as to trigger the execution of the message (i.e. a message will only be executed upon the ID value changing).

Message Information

This register contains information about whether the message is a command or a response, and may also indicate an error (see below).

b15 b14 b13 b12 b11 b10 b9 b8 b7 b6 b5 b4 b3 b2 b1 b0

Err	C/ R	(reserved)	Error Code	Message Type
-----	---------	------------	------------	--------------

For example, a command message will always contain the value 4002h in this register. A response message will contain 0002h, and may contain error information as detailed in the table below.

Bit/Field	Description	Contents
Err	This bit indicates if the received message contains any errors	0: Message OK 1: Error
C/R	This bit indicates if the message is a command or a response	0: Response Message 1: Command Message
Error Code	If the Err bit is set this field contains additional error information	0h: Invalid Message ID 1h: Invalid Message Type 2h: Invalid Command 3h: Invalid Data Size 4h-6h: Message header malformed 8h: Invalid Response 9h: Flash Config Error Fh: Invalid Other (All other values are reserved)
Message Type	This field specifies the message type	2h: This field must always equal 2.

Command Number

This register contains a 16 bit command identifier, which contains the identifier corresponding to the exact message command to be executed.

Data Size

This register specifies the size of the Message Data in bytes. The maximum Message Data size is 256 bytes.

Extended Words 1 ... 8

These registers are specific for each command. Consult the specification for each command for further information.

Message Interface Addressing

Command messages and response messages are allocated fixed locations in the radio interface (I/O Registers). Also, spontaneously generated alarm messages are allocated unique fixed locations in the radio interface. The memory allocation of these messages in the radio interface is outlined in the table below.

I/O Register	Purpose
4550 - 4689	Message IN Area (i.e. Messages to send <i>to</i> Profibus Interface)
4700 - 4839	Message OUT Area (i.e. Messages <i>from</i> Profibus Interface)
4850 - 4899	Spontaneous Message OUT Area (i.e. Alarm Messages <i>from</i> Profibus)
4900 – 4949	Spontaneous Alarm ACK IN Area (i.e. ACK <i>to</i> above)

For example, a message could be sent to the Profibus Interface by constructing the required message in the “Message IN Area”, either via radio using appropriate block mapping(s) or locally via a host device or configuration tool. This message is activated upon change-of-state of the Message ID field (see “Message Structure” above). The profibus interface may generate a response to this message in the “Message OUT Area”, which may then also be transmitted via radio using appropriate block mappings or locally via the host device.

Set Slave Mode

SET_SLAVE_MODE: Command Number = 0003h.

In addition to station related user data transfer, which is executed automatically, the master can send control commands to a single slave, a group of slaves or all slaves simultaneously. These control commands are transmitted as multicast commands. This permits use of sync and freeze modes for event controlled synchronisation of the slaves.

The slaves begin sync mode when they receive a sync command from their assigned master. The outputs of all addressed slaves are then frozen in their current state. During subsequent user data transmissions, the output data are stored at the slaves, but the output states remain unchanged. The stored output data are not sent to the outputs until the next sync command is received. Sync mode is concluded with the unsync command.

Similarly, a freeze control command causes the addressed slaves to assume freeze mode. In this operating mode, the states of the inputs are frozen until the master sends the next freeze command. Freeze mode is concluded with the unfreeze command.

Note : Not all slaves supports this feature. Consult the documentation for the actual slave for further information.

Command and response layout:

	Command		Response	
Message ID	(ID)		(ID)	
Message Information	4002h		0002h	
Command Number	0003h		0003h	
Data Size	0000h		0000h	
Extended Word 1	Slave Address	Group Select	Slave Address	Group Select
Extended Word 2	Control Command	-	Control Command	-
Extended Word 3	-		-	
Extended Word 4	-		-	
Extended Word 5	-		-	
Extended Word 6	-		-	
Extended Word 7	-		Extended Fault Info	
Extended Word 8	-		Fault Information	

- **Slave Address**

Range 1-125; 127

If the request applies for only one slave, that Slave Address must be entered in the range 1-125. If a slave group is to be addressed, Slave Address should be 127 (Multicast address).

- **Group Select**

Range 01h -FFh (Bit coded)

This parameter decides which group should be addressed, see below.

bit 7	bit 6	bit 5	bit 4	bit 3	bit 2	bit 1	bit 0
Group 8	Group 7	Group 6	Group 5	Group 4	Group 3	Group 2	Group 1

Example: To address Group 1, 2 and 4, the Group Select value should be 0Dh. If an individual slave should be addressed the correct group selection must also be made, since the slave will ignore the message if it does not belong to the requested group(s).

The group(s) a slave belongs to is determined during network configuration with ESeries Configuration Software, and is downloaded during initialisation to each slave via the Profibus telegram Set_Prm.

- **Control Command**

This parameter specifies the command to send.

Bit	Explanation
0 (LSB)	Reserved (set to zero)
1	Reserved (set to zero)
2	Unfreeze input data
3	Freeze input data
4	Unsynchronize output data
5	Synchronize output data
6	Reserved (set to zero)
7 (MSB)	Reserved (set to zero)

- **Fault Information & Extended Fault Information**

If 'Invalid Other' is returned in the Message Information word in the header of the response, information about the fault can be found here.

'Fault Information' contents		'Extended Fault Information' contents	
0001h	Address out of range	-	
0002h	Group number 0 not permitted	-	
000Ah	Failed to send Global Control request	000Ah	Incorrect operation mode
		5001h	Invalid Freeze group (Group is not initiated to be Freeze group)
		5002h	Invalid Sync group (Group is not initiated to be a Sync group)
		5003h	Incorrect Control Command
		5004h	No Sync-/ or Freeze groups enabled in master configuration.
00FFh	Module not initialised	-	

Get Slave Diagnostics

GET_SLAVE_DIAG: Command Number = 0004h

This command reads diagnostic data from a specified slave.

Note: The response data size depends on the actual slave implementation. Range 6 -244.

Command and response layout:

	Command		Response	
Message ID	(ID)		(ID)	
Message Information	4002h		0002h	
Command Number	0004h		0004h	
Data Size	0000h		(Size of data)	
Extended Word 1	Slave Address	Type of request	Slave Address	Type of request
Extended Word 2	-		-	
Extended Word 3	-		-	
Extended Word 4	-		-	
Extended Word 5	-		-	
Extended Word 6	-		-	
Extended Word 7	-		Extended Fault Info	
Extended Word 8	-		Fault Information	
	Response data word 1		Station Status 1	Station Status 2
	Response data word 2		Station Status 3	Master Address
	Response data word 3		Ident Number	
	Response data word 4		Extended Diagnostic Data	
	:::			
	Response data word n			

- **Slave Address**

Range 1-125, specifies the slave to read diagnostics from.

- **Type of request**

0x00: Internal slave diagnostic request. The diagnostic information stored in the master is returned. Can only be requested for slaves configured by the master.

0x01: External slave diagnostic request. A diagnostic request is sent on the network to the specified slave. Can be requested for all slaves on the network.

- **Station Status [1 ...3]**

Consult EN50170 Vol.2 for further information.

- **Master Address**

Address of the master that parameterized the slave

- **Ident Number**

Unique ID assigned by the Profibus User Organization

- **Extended Diagnostic Data**

Slave user specific diagnostic data. Consult the documentation for the actual slave for further information.

- **Fault Information & Extended Fault Information**

If 'Invalid Other' is returned in the Message Information word in the header of the response, information about the fault can be found here.

'Fault Information' contents		'Extended Fault Information' contents	
0001h	Address out of range	-	
000Ah	Failed to read Diagnostic Data from slave	0018h	DPMC_M_START has not yet occurred (DPMC_ERR_M_NOT_ALLOWED)
		002Bh	Buffer provided by the user is not sufficient. (DPMC_ERR_M_BLOCK_LEN_INVALID)
00FFh	Module not initialised	-	

Set Slave Address

SET_SLAVE_ADDRESS: Command Number = 0006h

This command makes it possible to set the node address of a specified slave, provided that the slave supports this feature.

Note: The message data size depends on the actual slave implementation; range 0 -240 bytes.

Command and response layout:

	Command		Response	
Message ID	(ID)		(ID)	
Message Information	4002h		0002h	
Command Number	0006h		0006h	
Data Size	(Size of data)		(Size of data)	
Extended Word 1	Current Slave Add	New Slave Add	Current Slave Add	New Slave Add
Extended Word 2	Slave Ident Number		Slave Ident Number	
Extended Word 3	No_add_Chg	-	No_add_Chg	-
Extended Word 4	-		-	
Extended Word 5	-		Err Code1	Err Code2
Extended Word 6	-		Err Code3	Err Code4
Extended Word 7	-		Return Code	
Extended Word 8	-		Fault Information	
Message data byte 1	Slave Data 1		Slave Data 1	
...	
Message data byte n	Slave Data n		Slave Data n	

- **Current Slave Address**

Range 1-125, specifies the current address of the slave

- **New Slave Address**

Range 1-125, specifies the new address of the slave

- **Slave Ident Number**

Ident number for the slave, whose address should be altered

- **No_add_Chg**

This parameter specifies whether it is allowed to change the slave address again at a later stage. If this is not allowed, then it is only possible to change the address with this function after initial reset. After the initial reset the slave takes the default address 126.

00h: Change of address is still possible at a later stage

01h-FFh: Change of address only possible after the initial address (i.e. default address = 126)

- **Error Code [1 ...4]**

If 'Return Code ' equals 8030h ('Negative indication from lower layer '), status values according to the DP-specification are available in 'Error Code 1 '. Error Codes 2 ...3 are reserved.

(See "Return Codes" and "Error Codes" in section 4.10.5 below.)

- **Return Code**

See "Return Codes" in section 4.10.5 "DP Error Codes".

- **Fault Information**

If 'Invalid Other 'is returned in the Message Information word in the header of the response, information about the fault can be found here.

0001h: Current slave address out of range.

0002h: New slave address out of range.

000Ah: Failed to execute request.(See 'Return Code ' for additional fault information))

000Bh: Remote station failure.(See 'Return Code ' for additional fault information)

00FFh: Module not initialised.

- **Slave Data**

With this parameter it is possible to deliver user specific data. The data is stored in the slave if possible (i.e. EEPROM, FLASH etc.)

Get Live List

GET_LIVE_LIST: Command Number = 0018h

This command returns 127 bytes of information about the nodes on the network. Every byte stands for one bus subscriber, and the position of the byte in the response data assigns the address

Command and response layout:

	Command	Response
Message ID	(ID)	(ID)
Message Information	4002h	0002h
Command Number	0018h	0018h
Data Size	0000h	007Fh
Extended Word 1	-	-
Extended Word 2	-	-
Extended Word 3	-	-
Extended Word 4	-	-
Extended Word 5	-	-
Extended Word 6	-	-
Extended Word 7	-	Return Code
Extended Word 8	-	Fault Information
	Response data byte 1	Station Type 0
	Response data byte 2	Station Type 1

	Response data byte 127	Station Type 126

- **Station Type [0 ...126]**

00h: Slave Station

01h: Master Station not yet ready for Token ring (station only physically at the bus)

02h: Master Station ready to enter Token ring (there is not yet any Token transmission)

03h: Master Station in Token ring (Token transmission through the station)

04h: Station does not exist

- **Fault Information**

If 'Invalid Other' is returned in the Message Information word in the header of the response, information about the fault can be found here.

000Ah: Failed to build Live List

00FFh: Module not initialised

DPV1 Acyclic Read

MSAC1_READ: Command Number = 0020h

This command initiates a DPV1 Class 1 acyclic read request. Consult EN50170 (DPV1) for more information.

Command and response layout:

	Command		Response	
Message ID	(ID)		(ID)	
Message Information	4002h		0002h	
Command Number	0020h		0020h	
Data Size	0000h		(Size of data)	
Extended Word 1	Slave Add	Slot No.	Slave Add	Slot No.
Extended Word 2	Index	Length	Index	Length
Extended Word 3	-		-	
Extended Word 4	-		-	
Extended Word 5	-		-	Error Decode
Extended Word 6	-		Err Code1	Err Code2
Extended Word 7	-		Return Code	
Extended Word 8	-		Fault Information	
	Response data byte 1		Data 1	
	Response data byte 2		Data 2	
	
	Response data byte n		Data n	

- **Slave Address**

Station address of the slave responder

- **Slot Number & Slot Index**

Used in the slave to address the desired data block.

- **Length**

This parameter specifies the number of bytes of the data block that has to be read. If the server data block length is less than requested, the length of the response will be the actual length of the data block. If the server data block is greater or equal, then the response will contain the same amount of data.

The slave may answer with an error response if the data access is not allowed.

- **Data [1 ...n]**

Returned data

- **Return Code**

See "Return Codes" in section "DP Error Codes" below.

- **Fault Information**

If 'Invalid Other' is returned in the Message Information word in the header of the response, information about the fault can be found here.

0001h: Address out of range

000Ah: Failed to execute MSAC1_Alarm_Ack request

000Bh: Remote station failure

0010h: Remote Station DPV1 Failure (see 'Error Decode' below).

00FFh: Module not initialised

- **Error Decode, Error Code 1 & Error Code 2**

If 'Fault Information' contains error code 0010h, more information according to the DPV1 specification can be found here.

DPV1 Acyclic Write

MSAC1_WRITE: Command Number = 0021h

This command initiates a DPV1 Class 1 acyclic write request. Consult EN50170 (DPV1) for more information.

Command and response layout:

	Command		Response	
Message ID	(ID)		(ID)	
Message Information	4002h		0002h	
Command Number	0021h		0021h	
Data Size	(Size of data)		(Size of data)	
Extended Word 1	Slave Add	Slot No.	Slave Add	Slot No.
Extended Word 2	Index	Length	Index	Length
Extended Word 3	-		-	
Extended Word 4	-		-	
Extended Word 5	-		-	Error Decode
Extended Word 6	-		Err Code1	Err Code2
Extended Word 7	-		Return Code	
Extended Word 8	-		Fault Information	
Message data byte 1	Data 1		Data 1	
...	
Message data byte n	Data n		Data n	

- **Slave Address**

Station address of the slave responder

- **Slot Number & Slot Index**

Used in the slave to address the desired data block.

- **Length**

This parameter specifies the number of bytes that has to be written. If the destination data block size is less than requested, the response will contain an error message. If the data block length is greater than or equal to the requested length, the response contains the number of bytes that has been written. The slave may answer with an error response if the data access is not allowed.

- **Data [1 ...n]**

Data that should be written.

- **Fault Information**

If 'Invalid Other' is returned in the Message Information word in the header of the response, information about the fault can be found here.

0001h: Address out of range

000Ah: Failed to execute MSAC1_Alarm_Ack request

000Bh: Remote station failure

0010h: Remote Station DPV1 Failure (see 'Error Decode' below).

0011h: Too much data is sent to the slave (more than Max_Channel_Data_Len)

00FFh: Module not initialised

- **Error Decode, Error Code 1 & Error Code 2**

If 'Fault Information' contains error code 0010h, more information according to the DPV1 specification can be found here.

Alarm Indication

MSAL1_ALARM_IND: Command Number = 0022h

This message indicates that a DPV1 slave has transferred an Alarm message to the master. This message is sent spontaneously by the 905G, i.e. the module itself initiates the message instruction in the “Spontaneous Message OUT Area” (see “Message Interface Addressing” above).

Detailed information about the alarm cause is presented in extended words 1-3 and the message data field, see below.

The 905G may be configured to automatically provide a response to this command (default), or the response may be provided externally via the message interface. The response will trigger the module to send an MSAC1_Alarm_Ack to the slave. This will tell the slave that the master has configured the alarm. The slave will in turn respond with a confirmation message, see “Alarm Confirmation (MSAL1_ALARM_CON)” below.

Command and response layout:

	Command		Response
Message ID	(ID)		(ID)
Message Information	4002h		0002h
Command Number	0022h		0022h
Data Size	(request length)		0000h
Extended Word 1	Slave Add	Slot No	-
Extended Word 2	Seq Number	Alarm Spec Ack	-
Extended Word 3	Alarm Type	Ext Diag	-
Extended Word 4	-		-
Extended Word 5	-		-
Extended Word 6	-		-
Extended Word 7	-		-
Extended Word 8	Fault Information		-
Message data byte 1	Data 1		
...	...		
Message data byte n	Data n		

- **Slave Address**

Station address of the slave that indicates the alarm

- **Slot Number**

Used by the slave to indicate the source of the alarm.

Range 0 -254

- **Seq Number**

Unique identification number of the alarm.

Range 0 -31

- **Alarm Spec Ack**

Gives additional information about the Alarm, such as an error appears, or disappears. It also indicates whether the slave needs additional acknowledge from the Master (Example: Writing to a certain memory area with an Acyclic Write request).

Range 0 -7

- **Alarm T ype**

Identifies the alarm type, such as Process Alarm, Plug Alarm etc.

Range 1 -6, 32 -126

- **Extended Diagnostic Flag**

FFh: Slave sends an alarm message with “Extended Diag flag ”set

00h: Slave sends an alarm message with “Extended Diag flag ”cleared

- **Data [1 ...n]**

Additional manufacturer specific alarm information (Alarm -PDU)

- **Fault Information**

If the Message Information word in the header of the message indicates ‘Invalid Other’, additional information is available in this register.

003Eh: Module has received an invalid alarm indication data structure from a DPV1 slave. (‘Slave Address ’ contains the node address of the slave that issued the erroneous indication)

Note: A response does not have to be sent in this case, since the module can ’t send an Alarm Acknowledge to the slave because of this fault.

Alarm Confirmation

FB_ABM_MSAL1_ALARM_CON: Command Number = 0023h

This message indicates that a slave has confirmed a previous MSAC1_Alarm_Ack, see “Alarm Indication (MSAL1_ALARM_IND)” above. This message is sent spontaneously by the 905G, i.e. the module itself initiates the message instruction in the “Spontaneous Message OUT Area” (see “Message Interface Addressing” above).

Note: This message must *not* be responded to!

Message layout:

	Command		Response
Message ID	(ID)		(no response)
Message Information	4002h		
Command Number	0023h		
Data Size	0000h		
Extended Word 1	Slave Add	Slot No	
Extended Word 2	Seq Number	Alarm Spec Ack	
Extended Word 3	Alarm Type	Ext Diag	
Extended Word 4	-		
Extended Word 5	-	Error Decode	
Extended Word 6	Err Code1	Err Code2	
Extended Word 7	Return Code		
Extended Word 8	Fault Information		

- **Slave Address**

Station address of the slave that indicates the alarm

- **Slot Number**

Used by the slave to indicate the source of the alarm

Range 0 -254

- **Seq Number**

Unique identification number of the alarm

Range 0 –31

- **Alarm Spec Ack**

Gives additional information about the Alarm, such as an error appears, or disappears. It also indicates whether the slave needs additional acknowledge from the Master

(Example: Writing to a certain memory area with an Acyclic Write request)

Range 0 -7

- **Alarm Type**

Identifies the alarm type, such as Process Alarm, Plug Alarm etc.

Range 1 -6, 32 -126

- **Extended Diagnostic Flag**

FFh: Slave sends an alarm message with “Extended Diag flag ”set

00h: Slave sends an alarm message with “Extended Diag flag ”cleared

- **Fault Information**

If ‘Invalid Other ’is returned in the Message Information word in the header of the response, information about the fault can be found here.

000Ah: Failed to execute MSAC1_Alarm_Ack request

000Bh: Remote station failure

0010h: Remote Station DPV1 Failure (see ‘Error Decode’ below).

- **Error Decode, Error Code 1 & Error Code 2**

If ‘Fault Information’ contains error code 0010h, more information according to the DPV1 specification can be found here.

4.10.5 DP Return Codes

Possible DP error codes in Message Data word 'Return Code '

Return Code	Name	Meaning
8010h	DPMC_ERR_V1C_CLOSED	Internal DPMC instance no longer exists.
8011h	DPMC_ERR_V1C_STOPPED	Internal DPMC instance already stopped
8012h	DPMC_ERR_V1C_STARTED	Internal DPMC instance already started
8013h	DPMC_ERR_V1C_STATE_UNKNOWN	Internal DPMC instance has entered an undefined state
8021h	DPMC_ERR_V1C_REQ_ACTIVE	A request is already active
8022h	DPMC_ERR_V1C_NOT_ALLOWED	Internal DPMC module not initialized
8023h	DPMC_ERR_V1C_INVALID_PAR	Invalid parameter in user request
8024h	DPMC_ERR_V1C_MEM_ALLOC	Internal memory allocation error
8025h	DPMC_ERR_V1C_L2_REQ	Unknown opcode in the confirmation
8026h	DPMC_ERR_V1C_TIMEOUT	Active request terminated with timeout
8028h	DPMC_ERR_V1C_INVALID_LEN	Invalid length in user request
8030h	DPMC_ERR_V1C_REQ_NEG*	Negative indication from lower layer
8031h	DPMC_ERR_V1C_REQ_RE	Message frame format error in response
8042h	DPMC_ERR_V1C_REQ_WITHDRAW	Request was recalled
8043h	DPMC_ERR_V1C_REQ_NOT_FOUND	Associated request block not found
80C1h	DPMC_ERR_V1C_MM_FE	Format error in request frame
80C2h	DPMC_ERR_V1C_MM_NI	Function not implemented
80C3h	DPMC_ERR_V1C_MM_AD	Access denied
80C4h	DPMC_ERR_V1C_MM_EA	Area too large
80C5h	DPMC_ERR_V1C_MM_LE	Data block length too large
80C6h	DPMC_ERR_V1C_MM_RE	Format error in response frame
80C7h	DPMC_ERR_V1C_MM_IP	Invalid parameter
80C8h	DPMC_ERR_V1C_MM_SC	Sequence conflict
80C9h	DPMC_ERR_V1C_MM_SE	Sequence error
80CAh	DPMC_ERR_V1C_MM_NE	Area non-existent
80CBh	DPMC_ERR_V1C_MM_DI	Data incomplete or incorrect
80CCh	DPMC_ERR_V1C_MM_NC	Master parameter set not compatible

* See "Error Codes" below.

Error Codes

If return code indicates 'DPMC_ERR_V1C_REQ_NEG', the status values according to the DP-standard may be available in 'Error Code 1' (See below). Consult the Profibus DP specification for information on how to interpret these status values.

Error Code	Name	Meaning
01h	L2_STATUS_UE	Consult Profibus DP Specification
02h	L2_STATUS_RR	
03h	L2_STATUS_RS	
0Ch	L2_STATUS_RDL	
0Dh	L2_STATUS_RDH	
0Fh	L2_STATUS_NA	

DPV1 Return Codes

Possible DPV1 related Error Codes in Message Data word 'Return Code'

Return Code	Name	Meaning
0003h	DPMC_ERR_M_MEM_ALLOC	Internal memory allocation error
0004h	DPMC_ERR_M_L2_REQ	Unknown opcode in the confirmation
0005h	DPMC_ERR_M_INVALID_PAR	Invalid parameter in user request
0007h	DPMC_ERR_M_NOT_IN_DATA	Slave is not in DataExchange (thus no DPV1 request can exist)
0012h	DPMC_ERR_M_REQ_ACTIVE	A request is already active
0018h	DPMC_ERR_M_NOT_ALLOWED	Internal DPMC module not initialized correctly
0021h	DPMC_ERR_M_CLOSED	Internal DPMC instance no longer exists
0022h	DPMC_ERR_M_STOPPED	Internal DPMC instance has already been stopped
0023h	DPMC_ERR_M_STARTED	Internal DPMC instance has already been started
0024h	DPMC_ERR_M_STATE_UNKNOWN	Internal DPMC instance has entered an undefined state
002Fh	DPMC_ERR_M_SLAVE_NOT_FOUND	Slave does not respond
0031h	DPMC_ERR_M_TIMEOUT	Active request terminated with timeout
0034h	DPMC_ERR_M_INVALID_LEN	Invalid length in user request
0035h	DPMC_ERR_M_REQ_NEG	Negative indication from lower layer
0036h	DPMC_ERR_M_REQ_RE	Message frame format error in response
0037h	DPMC_ERR_M_REQ_WITHDRAW	Request was recalled
0038h	DPMC_ERR_M_REQ_NOT_FOUND	Associated request block not found
0040h	DPMC_ERR_M_MM_FE	Format error in request frame
0041h	DPMC_ERR_M_MM_NI	Function not implemented
0042h	DPMC_ERR_M_MM_AD	Access denied
0043h	DPMC_ERR_M_MM_EA	Area too large
0044h	DPMC_ERR_M_MM_LE	Data block length too large
0045h	DPMC_ERR_M_MM_RE	Format error in response frame
0046h	DPMC_ERR_M_MM_IP	Invalid parameter
0047h	DPMC_ERR_M_MM_SC	Sequence conflict
0048h	DPMC_ERR_M_MM_SE	Sequence error
0049h	DPMC_ERR_M_MM_NE	Area non-existent
004Ah	DPMC_ERR_M_MM_DI	Data incomplete or incorrect
004Bh	DPMC_ERR_M_MM_NC	Master parameter set not compatible
004Ch	DPMC_ERR_M_S7_XA	Profibus error for DPV1 (NRS-PDU received)
004Dh	DPMC_ERR_M_S7_XR	
004Eh	DPMC_ERR_M_S7_XW	

4.11 Fieldbus Configuration - Ethernet

The 905G provides the following Ethernet functionality:

1. Modbus/TCP. The module supports the Modbus/TCP protocol and conforms to the Modbus/TCP specification 1.0 (full information on this protocol can be obtained from <http://www.modicon.com/openmbus/index.html>). Refer to section 4.10.2 below for configuration details.
2. EtherNet/IP. EtherNet/IP is based on the Allen-Bradley Control and Information protocol, CIP, which is also the framework for both DeviceNet and ControlNet, to carry and exchange data between nodes. Refer to section 4.10.3 below for configuration details.

Note! The 905G only supports true EtherNet IP commands as found in A-B ControlLogix, MicroLogix, and CompactLogix PLC's, but does not support earlier A-B Ethernet commands used with SLC5 PLC's.

3. IT-Functionality. The Ethernet 905G has several IT features, including Internet functionality.
 - Filesystem. The module features a flexible file system with two security levels. The size available for user files is approximately 1.4 Mbyte of non-volatile memory.
 - FTP Server. The FTP Server provides easy file management using standard FTP clients.
 - Telnet Server. The Telnet server features a command line interface similar to the MS-DOS™ environment.
 - HTTP Server. The module features a flexible HTTP server with SSI functionality. This enables the user to configure a web interface (or web page) accessing I/O values in the 905G.
 - Email Client (SMTP). Predefined messages stored within the file system can be sent, triggered by a specified I/O value in the 905G. It is also possible to include I/O values in emails, using SSI functionality.
 - IP Access Control. It is possible to configure which IP addresses and what protocols that are allowed to connect to the module.

For further details, refer to Appendix 2.

4.11.1 Setting IP Address

The Ethernet IP address can be set from the configuration software or via the Ethernet port or via the selector switches in the top end-plate of the module. If the “Enable Switch Address” box is not selected, then the address entered in the program will be used and the switch value ignored. The IP address can be overwritten from the Ethernet port. If the “Enable Switch Address” box is selected, then the address entered in the configuration program will be ignored and the rotary switch read on start-up of the 905G.

The IP address is used to identify each node on the Ethernet network. Therefore, each node on the network must have a unique IP address. IP addresses are written as four decimal integers (0-255) separated by periods, where each integer represents the binary value of one byte in the IP address. This is called dotted-decimal notation. Example: 169.254.100.175

Subnet Mask

An IP Address is divided into two main parts *subnet ID* and *host ID*. All devices on the same local network must have the same subnet ID, but a unique host ID. To separate these two parts a *subnet mask* is used. In its simplest form, the subnet mask is a four byte pattern where a value of 255 allocates the corresponding byte of the IP Address to the subnet ID, and a value of 0 allocates the corresponding byte of the IP Address to the host ID.

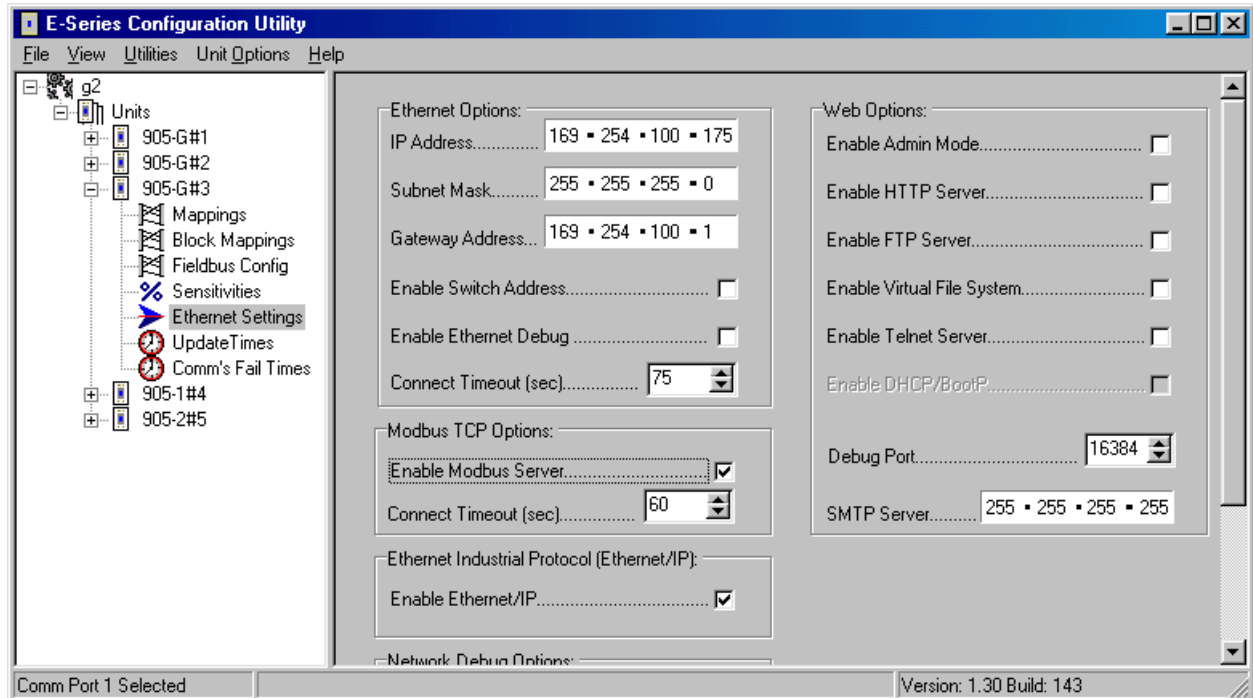

For example, a common subnet mask is shown in the example below. Looking at the IP Address located directly above the Subnet Mask in this example, it can be seen that the IP Address values directly above a subnet mask value of 255 correspond to the subnet ID. Conversely, the IP Address values directly above a subnet mask value of 0 correspond to the host ID. So, in this example, the subnet ID is 169.254.100 and the host ID is 175.

Special case IP addresses

Devices on an Ethernet network are not allowed to be configured to the following IP addresses; therefore do not configure the module to use any of them.

0.x.x.x - IP address where the first byte is zero
127

127.x.x.x - IP address where the first byte is

x.x.x.0 - IP address where the last byte is zero
255

x.x.x.255 - IP address where the last byte is

Gateway

The Gateway IP is the IP address of the LAN server or the host device.

Connect Timeout

The Connect Timeout parameter in the IP addressing section of the display refers to the IP functionality of the module. If an IP connection to the module has not been active for this amount of time, the 905G will timeout and disconnect that connection. Note that there can be several active connections at the same time - only the inactive connection will be disconnected.

Enable Ethernet Debug

Select this box if you wish to enable Ethernet Diagnostics on the 905G via configuration software (see section 6.3 for details). For security reasons, disabling this option will disallow all Ethernet diagnostics functions accessible to configuration software, and can only be reactivated via serial port configuration.

4.11.2 Modbus TCP

To use Modbus TCP, select the Enable Modbus Server box and deselect the Enable Ethernet/IP box. This will automatically remove the “I/O Instance” selection for all fieldbus mappings. It is possible for both Modbus TCP and Ethernet/IP to be selected - in this case, select “Disable I/O Instance” individually for each Modbus TCP fieldbus mapping.

Supported Commands:

Function Code	Function Name	Class	Affects Area	Address Method
1	Read coils	1	IN/OUT	Bit
2	Read Input discretes	1	IN/OUT	Bit
3	Read multiple registers	0	IN/OUT	Word
4	Read input registers	1	IN/OUT	Word
5	Write coil	1	OUT	Bit
6	Write single register	1	OUT	Word
7	Read exception status	1	-	-
15	Force multiple coils	2	OUT	Bit
16	Force multiple registers	0	OUT	Word
22	Mask write register	2	OUT	Word
23	Read/Write registers	2	IN/OUT	Word

Supported Exception Codes:

Exception Code	Name	Description
01	Illegal function	The module does not support the function code in the query
02	Illegal data address	The data address received in the query is outside the initialized memory area
03	Illegal data value	The data in the request is illegal

Modbus/TCP Addressing

The IN and OUT areas of the Ethernet interface are addressed under Modbus/TCP according to the tables below. Since Modbus uses a 16-bit format, “Word (16-bit) Address Mode” will be automatically applied whenever the “Modbus/TCP” checkbox is checked. If Ethernet/IP is

also enabled, the “Disable I/O Instance” option must be selected for each fieldbus mapping to which Modbus/TCP Addressing is to apply.

IN Area Modbus TCP Addresses (905G Write Locations 0 – 1023*)

IN Area Location	Modbus Word Address	Modbus Bit Address						
		Bit 15	Bit 14	Bit 13	---	Bit 2	Bit 1	Bit 0
0	1	1	2	3	---	14	15	16
1	2	17	18	19	---	30	31	32
---	---	---	---	---	---	---	---	---
1022	1023	16353	16354	16355	---	16382	16383	16384
1023	1024	16369	16370	16371	---	16382	16383	16384

OUT Area Modbus TCP Addresses (Fieldbus READ Locations 0 – 1023*)

OUT Area Location	Modbus Word Address	Modbus Bit Address						
		Bit 15	Bit 14	Bit 13	---	Bit 2	Bit 1	Bit 0
0	1025	16385	16386	16387	---	16398	16399	16400
1	1026	16401	16402	16403	---	16414	16415	16416
---	---	---	---	---	---	---	---	---
1022	2047	32737	32738	32739	---	32750	32751	32752
1023	2048	32753	32754	32755	---	32766	32767	32768

* Assumes Word Mode Addressing is selected in Configuration Software

The Fieldbus IN and OUT areas can be configured to a maximum size of 1024 words (2048 bytes) each, depending on the configured fieldbus mappings. The highest mapped location will correspond to the highest available Modbus register (or coil) available to a Modbus/TCP client. A Modbus/TCP client must use the appropriate Modbus Coil or Modbus Word addresses corresponding to configuration software, as well as the correct function code (see 4.10.2 Supported Commands).

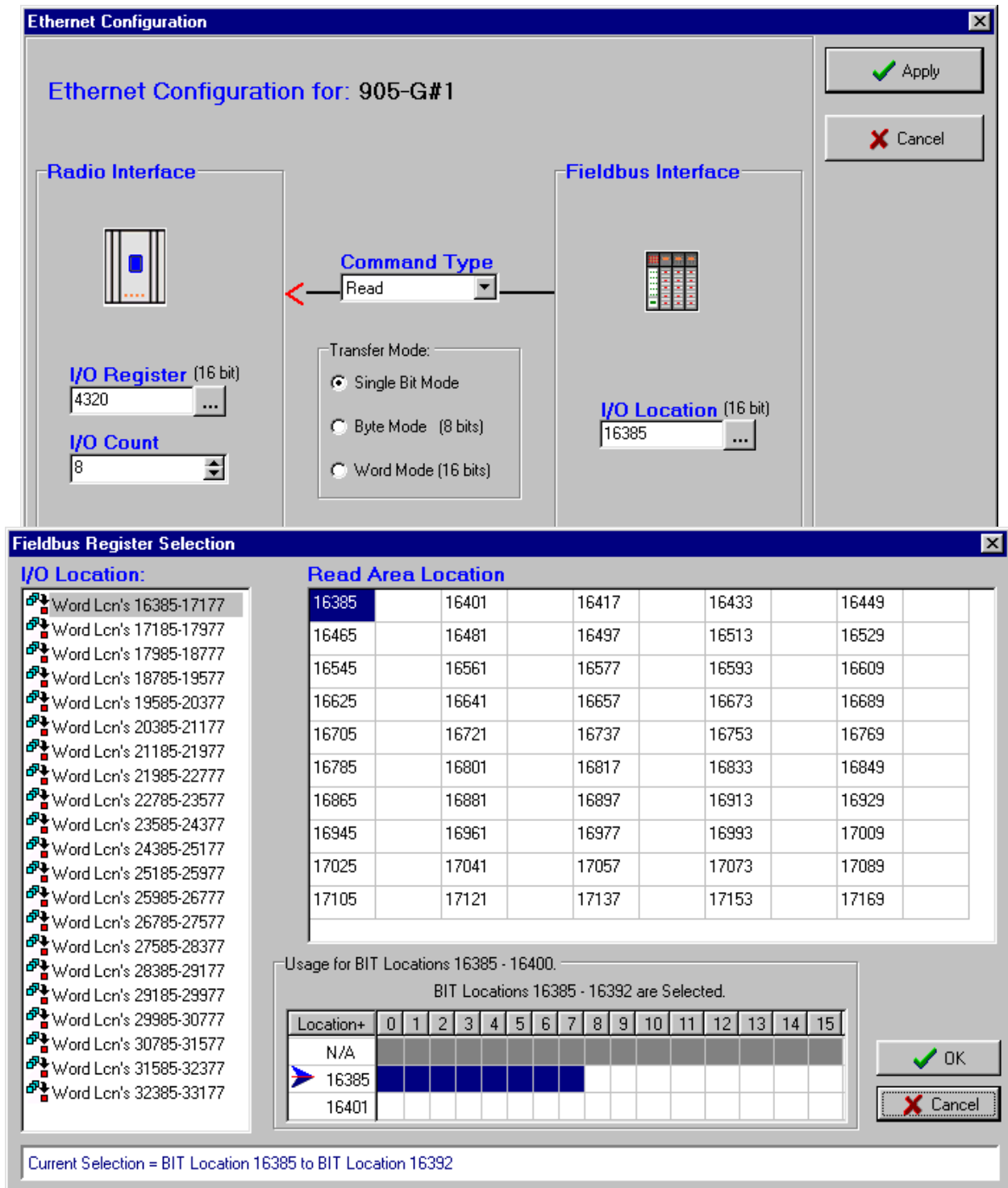

Appropriate Modbus prefixes may need to be added to the Modbus Address depending on the host device. For example, a "word write" fieldbus mapping in the 905G to Modbus location 10, can be read by a host device as 30010 (30000 for an input register + 10 as the address).

Alternatively, a “word read” fieldbus mapping in the 905G from Modbus Location 1025, can be written to by a host device as 41025 (40000 for an output register + 1025 as the address).

Conversely, for Modbus bit/binary commands the appropriate 0x or 1x prefix may need to be added depending on the host device. The example below shows 8 bits being read from Modbus locations 16385 – 16392 into I/O registers 4300 – 4307 (DOT 1-8). The Modbus/TCP host device would write to these as Modbus addresses 016385 – 016392 (using the 0x prefix to denote output coils).

Connect Timeout

The Connect Timeout parameter in the Modbus TCP section of the display refers to the Modbus TCP functionality of the module. If a TCP connection to the module has not been active for this amount of time, the 905G will timeout and disconnect that connection. Note that there can be several active connections at the same time - only the inactive connection will be disconnected.

4.11.3 EtherNet/IP

Ethernet/IP (Ethernet Industrial Protocol) is based on the Control and Information Protocol (CIP), which is also the framework for both DeviceNet and ControlNet, to carry and exchange data between nodes. The Ethernet/IP implementation is a Level 2 I/O Server, which means that the module will respond to both explicit and IO messages but requires that an Ethernet/IP client initiate IO connections.

For additional information on the Ethernet/IP protocol see www.ethernet-ip.org and www.odva.org. The rest of this section assumes the reader is familiar with Ethernet/IP.

If you use the 905U-G with a PLC, the PLC configuration tool will require an EDS file so it can recognize the Ethernet/IP interface in the 905U-G. The file is available on the same CD as the configuration software, or on the ELPRO web site.

Implemented Objects:

EtherNet/IP requires some mandatory objects; these are implemented, as well as some vendor specific objects. The mandatory objects are the ones in the specification from ODVA.

The following vendor specific objects are implemented:

- I/O data input mapping object, Class A0h
- I/O data output mapping object, Class A1h

The 905G can handle multiple EtherNet/IP connections simultaneously - up to 6 produced IO connections (“write” connections) and 6 consumed IO connections (“read” connections). Each connection is a “virtual” connection, not a “physical” connection and is called an “I/O instance”.

The maximum individual connection size is 512 bytes. If more than 512 bytes is to be transferred, then more than one connection is required - a connection is known as an “IO Instance”. Ethernet/IP interface to these IO connections is made available in the mandatory Ethernet/IP ‘Assembly Object’ (class 04h) as vendor specific instance attributes 64h-69h for produced IO (i.e. IO data configured using fieldbus *write* commands) and 96-9Bh for consumed IO (i.e. IO data configured using fieldbus *read* commands). The same IO are also available in the vendor specific objects I/O data input mapping object (class A0h) and IO data output mapping object (class A1h) respectively as instance attributes 1 – 6. (See Object Specifications below)

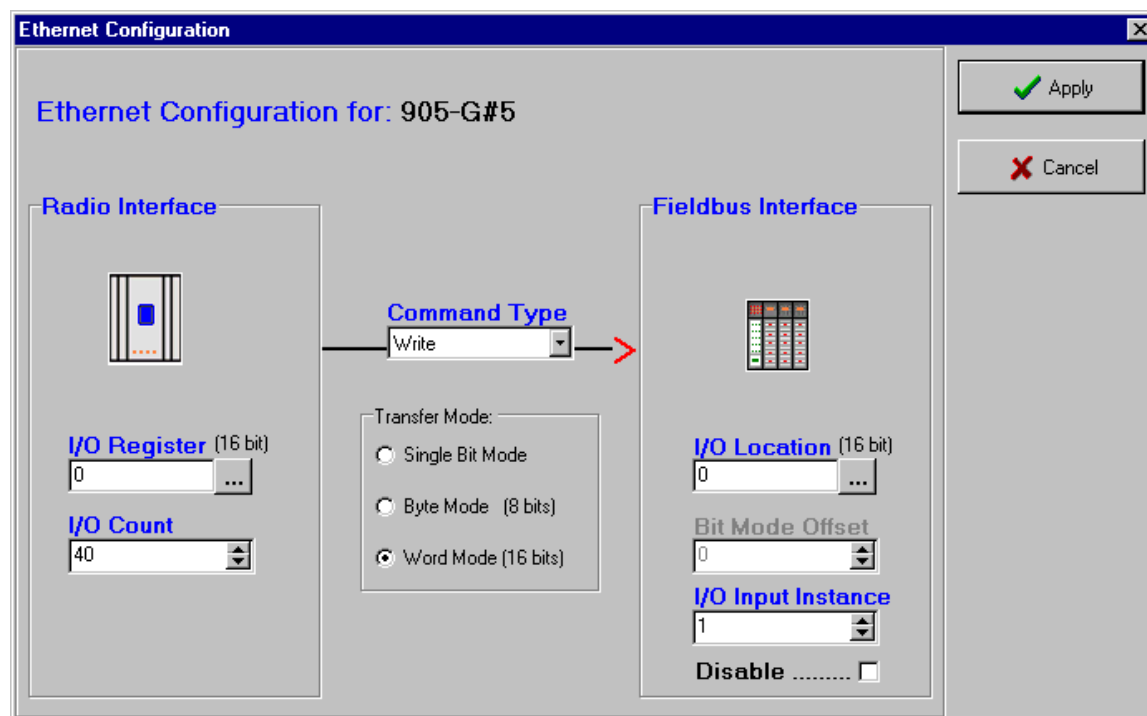

To make I/O data available via Ethernet/IP, ensure that the Enable Ethernet/IP checkbox on the Ethernet Settings page is checked. Appropriate Fieldbus Mappings need to be configured to link the required I/O registers to the Fieldbus Interface, as described above in the Profibus and Modbus/TCP sections. An “I/O Instance” for each fieldbus link must also be specified so that the configured I/O data is made available to one of the six possible Ethernet connections.

In this example, 40 I/O Registers (80 bytes) are transferred to I/O Input Instance 1 (i.e. Ethernet connection 1). As per the table below, this data would then be available via Ethernet/IP in class 04h, Instance Attribute 64h *or* in class A0h, Instance Attribute 1. If the *Disable* option is checked, the I/O transfer will not be made available to Ethernet/IP. The table below shows the possible IO Instances and their corresponding Ethernet/IP locations.

<i>IO Instance</i>	<i>Assembly Object</i>	<i>Vendor Specific Object</i>
IO Input Instance 1-6	Class 04h, Instance 64h-69h	Class A0h, Attribute 01h-06h
IO Output Instance 1-6	Class 04h, Instance 96h-9Bh	Class A1h, Attribute 01h-06h

Assembly Object, Class 04h

The Assembly Object binds all mapped I/O data. This data is used for I/O connections. This object is set-up dynamically via fieldbus mappings through configuration software.

Class Attributes:

ID#	Name	Service	Description	Semantics	Def, Min, Max	Type
01h	Revision	Get_attribute_all	Object Revision	The revision attribute containing the revision of the object	1, 1, 1	UINT

Input Area, Instance 64h:

ID#	Name	Service	Description	Type
03h	Data	Get_attribute_single	The data produced is configured from fieldbus write mappings to I/O Input Instance 1.	Array of USINT

Note: This data is also available in the vendor specific object: I/O Data Input Mapping Object, Class A0h, Instance Attribute 01h, and Attribute ID 01h (see I/O Data Input Mapping Object).

Input Area, Instance 65h – 69h:

ID#	Name	Service	Description	Type
03h	Data	Get_attribute_single	The data produced is configured from fieldbus write mappings to I/O Input Instance 2-6.	Array of USINT

Note: This data is also available in the vendor specific object: I/O Data Input Mapping Object, Class A0h, Instance Attribute 01h, and Attribute ID's 02h to 06h (see I/O Data Input Mapping Object).

Output Area, Instance 96h:

ID#	Name	Service	Description	Type
03h	Data	Get_attribute_single Set_attribute_single	The data produced is configured from fieldbus read mappings from I/O Output Instance 1.	Array of USINT

Note: This data is also available in the vendor specific object: I/O Data Output Mapping Object, Class A1h, Instance Attribute 01h, and Attribute ID 01h (see I/O Data Output Mapping Object).

Output Area, Instance 97h – 9Bh:

ID#	Name	Service	Description	Type
03h	Data	Get_attribute_single Set_attribute_single	The data produced is configured from fieldbus read mappings from I/O Output Instance 2-6.	Array of USINT

Note: This data is also available in the vendor specific object: I/O Data Output Mapping Object, Class A1h, Instance Attribute 01h, and Attribute ID 01h (see I/O Data Output Mapping Object).

I/O Data Input Mapping Object, Class A0h

This object is setup dynamically via fieldbus read mappings through configuration software. This data is also available as vendor specific Instance Attributes (64h to 69h) in the Assembly Object.

Class Attributes:

ID#	Name	Service	Description	Semantics	Def, Min, Max	Type
01h	Revision	Get_attribute_all	Object Revision	The revision attribute containing the revision of the object	1, 1, 1	UINT

Instance Attributes, Instance 01h:

ID#	Name	Service	Description	Type
01h	Data	Get_attribute_single	The data produced is configured from fieldbus write mappings to I/O Input Instance 1.	Array of USINT
...
06h	Data	Get_attribute_single	The data produced is configured from fieldbus write mappings to I/O Input Instance 6.	Array of USINT

I/O Data Output Mapping Object, Class A1h

This object is setup dynamically via fieldbus write mappings through configuration software. This data is also available as vendor specific Instance Attributes (96h to 9Bh) in the Assembly Object.

Class Attributes:

ID#	Name	Service	Description	Semantics	Def, Min, Max	Type
01h	Revision	Get_attribute_all	Object Revision	The revision attribute containing the revision of the object	1, 1, 1	UINT

Instance Attributes, Instance 01h:

ID#	Name	Service	Description	Type
01h	Data	Get_attribute_single Set_attribute_single	The data produced is configured from fieldbus write mappings to I/O Input Instance 1.	Array of USINT
...
06h	Data	Get_attribute_single Set_attribute_single	The data produced is configured from fieldbus write mappings to I/O Input Instance 6.	Array of USINT

4.12 Fieldbus Configuration – DeviceNet

4.12.1 DeviceNet Introduction

DeviceNet is a broadcast-oriented communications protocol based on the Controller Area Network (CAN). The physical fieldbus is a shielded copper cable composed of one twisted pair and two cables for the external power supply. The baud rate can be changed between 125k, 250k, and 500kbit/s via Configuration Software or DIP-switch.

DeviceNet has a user organization, the Open DeviceNet Vendor Association - for further information see www.ODVA.org

4.12.2 DeviceNet Address Setting

On a DeviceNet network, each node must be assigned its own unique Mac ID (Node Address). The Mac ID is a value between 0 and 63 used to identify each node. On the 905G DeviceNet module, the Mac ID and Baud rate settings can be set either using a physical DIP-switch or via the Configuration Software (Fieldbus Configuration page). To use the switch address settings, the “Enable Switch Address” option in configuration software must be selected, otherwise switch settings are ignored. We recommend that you do NOT use the DIP switch to set address/ baud rate as switches can be accidentally changed during operation

The DIP-switches are numbered 1 through 8. Switch 1 and 2 are used to configure the Baud rate, and switches 3 through 8 are used to configure the Mac ID using binary format (see tables below)

Mac ID Switch Setting:

Address	SW. 3 (MSB)	SW. 4	SW. 5	SW. 6	SW. 7	SW. 8 (LSB)
0	OFF	OFF	OFF	OFF	OFF	OFF
1	OFF	OFF	OFF	OFF	OFF	ON
2	OFF	OFF	OFF	OFF	ON	OFF
---	---	---	---	---	---	
62	ON	ON	ON	ON	ON	OFF
63	ON	ON	ON	ON	ON	ON

Baud Rate Settings:

Baud Rate, bit/sec	SW. 1	SW. 2
125k	OFF	OFF
250k	OFF	ON
500k	ON	OFF
Reserved	ON	ON

4.12.3 EDS File

Each device in a DeviceNet network is associated with an EDS file, containing all necessary information about the device. This file is used by the network configuration tool during

network configuration. The EDS file can either be downloaded from the ELPRO website (www.elprotech.com), or found on the Product CD supplied with the module.

4.12.4 Protocol and Supported Functions

The 905G DeviceNet module is implemented according to the ODVA specification for a communication adapter (profile no 12) and acts as a group two only server on the DeviceNet network.

The 905G DeviceNet supports the following connection types:

- Explicit Messaging
- Polled I/O
- Bit-strobed I/O
- Change-of-state / Cyclic I/O

The 905G DeviceNet supports up to 512 bytes of input and 512 bytes of output data via the DeviceNet interface. I/O Data exchange with a DeviceNet Scanner can be performed using any of the above connection types. DeviceNet Scanner configuration towards the 905G is possible via an EDS file.

DeviceNet is based on the Control and Information Protocol (CIP), which is also the framework for both ControlNet and Ethernet/IP, to carry and exchange data between nodes. The 905G supports the mandatory objects as well as some vendor specific objects. The mandatory objects are the ones in the specification from ODVA. The following vendor specific objects are implemented:

- I/O data input mapping object, Class A0h
- I/O data output mapping object, Class A1h

Since these objects are the same as for Ethernet/IP, for the specification of these objects see section '4.10.3 Ethernet/IP'. For further examples refer to the 905G DeviceNet Application Note.

4.13 Fieldbus Configuration – Modbus Plus

4.13.1 Modbus Plus Introduction

Modbus Plus is a local area network system designed for industrial control and monitoring applications. The network enables programmable controllers, host computers and other devices to communicate throughout plants and substations. Modbus Plus is normally used in industrial automation, to transfer fast data for motor controllers, MMI, I/O units and other industrial equipment.

The 905G Modbus Plus module communicates according to the Modbus Plus Protocol. This means that it can communicate with all Modbus Plus nodes that comply with this protocol, but it does not necessarily mean that all services available in the Modbus Plus protocol are supported.

4.13.2 Modbus Plus Addressing

Modbus Plus node addressing can be set using switches or via configuration software. To use the switch address settings, the “Enable Switch Address” option in configuration software must be selected, otherwise switch settings are ignored. NOTE – software address

configuration is the recommended option if use of the GDB Offset and Count parameters is required (see section 4.11.4).

Two sets of six switches are available: Node Address (S1, the left-most set of switches, closest to the D-SUB connector), and Source Address (S2, the right-most set of switches). Address settings for both switches use the same binary format illustrated in the table below.

1 MSB	2	3	4	5	6 LSB	Function
ON	ON	ON	ON	ON	ON	Node Address set to 1
ON	ON	ON	ON	ON	OFF	Node Address set to 2
ON	ON	ON	ON	OFF	ON	Node Address set to 3
---	---	---	---	---	---	
OFF	OFF	OFF	OFF	OFF	ON	Node Address set to 63
OFF	OFF	OFF	OFF	OFF	OFF	Node Address set to 64

4.13.3 Protocol & Supported Functions

Devices on a Modbus Plus network have two ways of exchanging data. One is through fast cyclic I/O data called Global Data, and one through a somewhat slower Modbus protocol for point-to-point parameter data transfer. The 905G supports both Global Data and point-to-point data, however the module cannot initiate point-to-point commands but only respond to and accept point-to-point commands initiated by other nodes on the network.

Modbus Plus is a token bus network. This means that each device on the network will receive the token on a cyclic basis. When a device on the network receives the token it is able to broadcast up to 32 words of Global Data. All other devices on the network will 'see' this data, and depending on their configuration have the option to use some, or all, of the broadcast data. Consequently, the 905G Modbus Plus module supports up to 32 words of Global Outputs (i.e. Data To Network) and up to 32 words of Global Inputs (i.e. Data From Network).

The 905G also supports point-to-point data, however the module cannot initiate point-to-point commands but only respond to and accept point-to-point commands. The 905G Modbus Plus supports only the following point-to-point operations on Modbus 40000 (4X) registers:

- (0x03) Read holding Registers
- (0x06) Preset Single Register
- (0x10) Preset multiple Registers

The 905G Modbus Plus supports the following exception responses:

- (0x01) Illegal function for the addressed slave
- (0x02) Illegal data address within the information field for the addressed slave
- (0x03) Illegal data value in the information field for the addressed slave

The 905G Modbus Plus supports up to 1024 words of output data and 1024 words of input data. Converting this to 40000 registers, the possible output registers (Data To Network)

range is 40001 – 41024 of which the first 32 words (i.e. 40001 – 40032) are global output data. However all output registers, including the global output registers, may also be read from the module using the point-to-point command Read Holding Registers (0x03). The possible input registers (Data From Network) range is 41025 – 42048 of which the first 32 words (i.e. 41025 – 41056) is global input data (i.e. data extracted from another network device's global output data). Only data *not* assigned to global input data (i.e. 41057 – 42048) may be written by the point-to-point preset register commands.

4.13.4 Configuration

The “Node Address” will be the Modbus Plus network address of the 905G, (allowable values are 1 – 64) and must be unique for the network segment. The “Source Address” will be the Modbus Plus network address of another module on the network from which the 905G will extract Global Data (i.e. Data From Network). “GDB I/P Count” (up to 32 words max) specifies the amount of Global Data to extract from the “Source Address” each cycle. An offset into the source unit's global data (“GDB I/P Offset”) may also be specified in order to read a specific portion of the 32 word global data of the source address. However, since only 32 words max of global data are produced, the sum of GDB I/P Offset and GDB I/P Count must never exceed 32. After setting these parameters, the 905G I/O Registers must be linked to Modbus Plus 40000 registers with appropriate “Fieldbus mappings”.

In the below example there is one “Fieldbus Write Mapping” (this will make available Data To Network) and one “Fieldbus Read Mapping” (this will make available Data From Network). When adding mappings, software will automatically adjust the available 40000 register address range depending on the command type (i.e. read or write fieldbus mapping), see below.

The I/O Register selection below for the fieldbus read mapping illustrates the allowable 40000 register address range base upon the chosen command type.

The fieldbus write mapping links the 48 I/O registers 0 – 47 to the fieldbus interface 4X registers 40001 – 40048. As described earlier, fieldbus interface registers 40001 – 40032 are always assigned as Global Data Out registers (i.e. Data To Network), these registers will be broadcast to the network on each token rotation cycle. The remaining registers (40033 – 40048) can be accessed via Modbus 40000 point-to-point Read Register commands described in section 4.10.4. NOTE - the option also exists for the Global Data output registers 40001 – 40032 to be read by the point-to-point commands also.

The fieldbus read mapping links the 48 fieldbus interface registers 41025 – 41072 to the I/O registers 50 – 97. As described earlier, fieldbus interface registers 41025 – 41056 are always assigned as Global Data In registers (i.e. Data From Network). These registers will be filled with Global Data broadcast by the “Source Unit” according to the “GDB I/P Offset” and “GDB I/P Count” parameters. In the above example, the values of the Offset = 0 and Count = 32, indicating that the entire 32 word Global Data broadcast from the Source Unit will be read into fieldbus interface registers 41025 – 41056. Other nodes on the network can write to the remaining registers (41057 – 41072) only by using the Modbus point-to-point Write Register commands described in section 4.10.3. NOTE – the point-to-point Write Register commands can *not* be used to write to the Global Data Input registers 41025 – 41056.

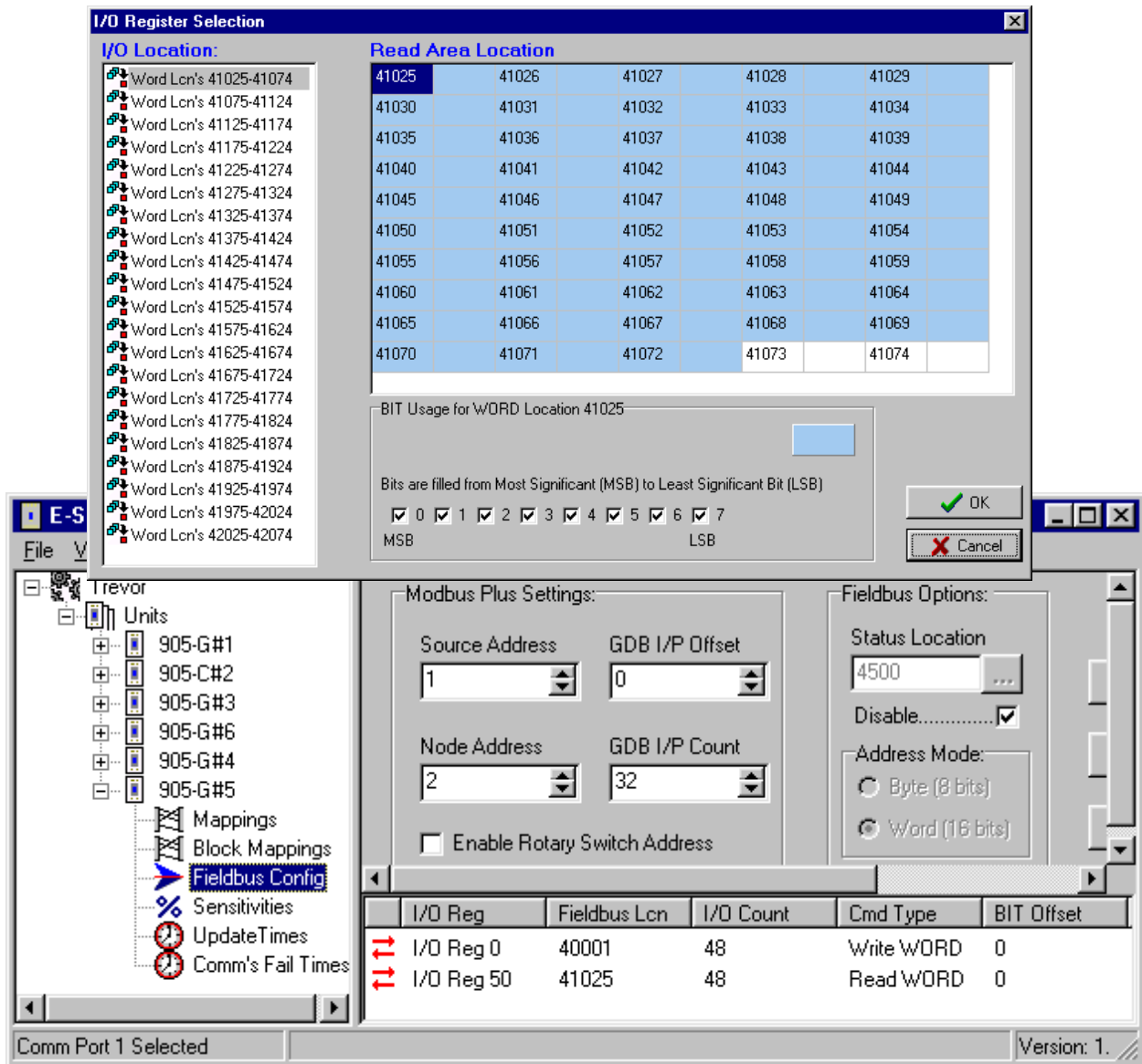

Finally, it must be taken into consideration that the 905G Modbus Plus module dynamically adjusts the 4X register range available to the network depending on the fieldbus mappings configured. The 905G will terminate the available 4X register range at the last mapped 4X register for both the read and write area. In the example above this means that the only 4X registers that are available to the Modbus Plus network are 40001 – 40048 and 41025 – 41072.

NOTE – considering this constraint, it is still strongly advised to use fieldbus interface registers always starting at the lowest addressed locations, thus limiting unnecessary processing overhead on the 905G.

4.14 Connecting 105S Serial I/O

NOTE – Serial I/O Expansion is only possible for 105G Firmware versions 1.50 onwards.

105S modules can be connected to the RS485 port of all 905G units except for the 905U-G-MD1 unit. 105S modules can be connected to the MD1 if the 905G is configured as “Repeater-only” - refer section 4.4.8.

Up to 31 x 105S addresses can be connected to each 905G. The 105S-1 and 105S-2 modules use one address per module, and the 105S-3 and 105S-4 modules take up two addresses.

To enable the 905G serial port for 105S expansion, select the “Enable Serial Expansion” box in the configuration software.

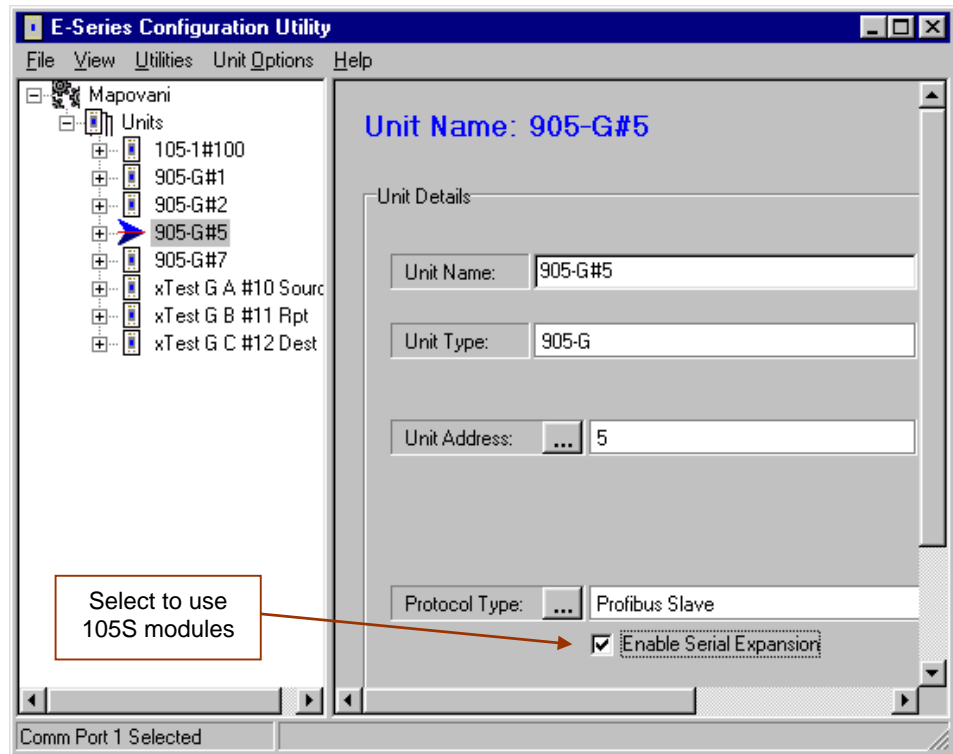

Note that enabling 105S expansion also disables on-line diagnostics via the serial port.

Mapping to or from the 105S I/O is the same as if the 105S modules are connected to a 905U I/O module. Each 105S module has an address between 96 and 127. The 905G acts as a repeater address in the mapping. The 905G I/O registers can also be mapped to/from the 105S I/O.

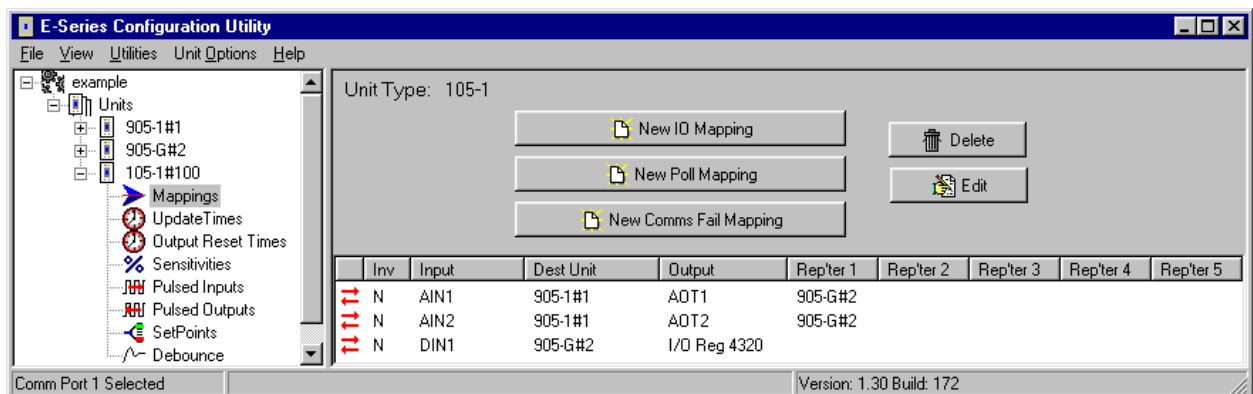

4.15 Uploading and Downloading

To upload or download a configuration file, the 905G must be connected to the PC via a RS232 cable. For Modbus/DF1 units, the host device must be disconnected, even if it is connected to the RS485 port. Other units do not need to disconnect the data bus. When the PC is connected, put the 905G into configuration mode by pressing the small pushbutton switch in the end plate of the module for 5 seconds, until the ACT LED starts flashing.

In configuration mode, the 905G will stop its normal functions.

Make sure the correct communications port is selected on the PC - if necessary, change the selection from the Utilities menu.

Connect the PC to the module using the configuration cable.

The configuration may be programmed into a 905G, or a configuration may be loaded from a 905G. After programming or loading is complete, disconnect the PC from the 905G. Reset the 905G by removing power and re-connecting power. The 905G will start up normally and the OK led will be on. The serial port will have its original set-up.

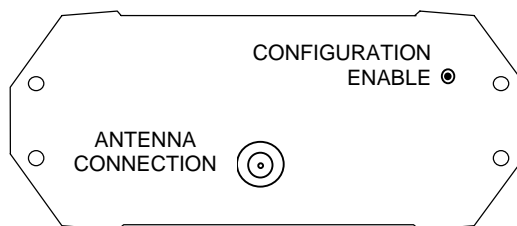

905U End DB9 Male		PC End DB9 Female	
1	_____	1	
2	██████████	2	
3	██████████	3	██████████
4	_____	4	Required
5	██████████	5	
6	_____	6	
7	_____	7	Optional
8	_____	8	
9	_____	9	

4.15.1 Loading from a 905G

If you load a configuration from a 905G into a “blank” or new project, then the program will not be able to display the mappings from remote modules (as the program does not know what the remote modules are). You will get a warning message like this:

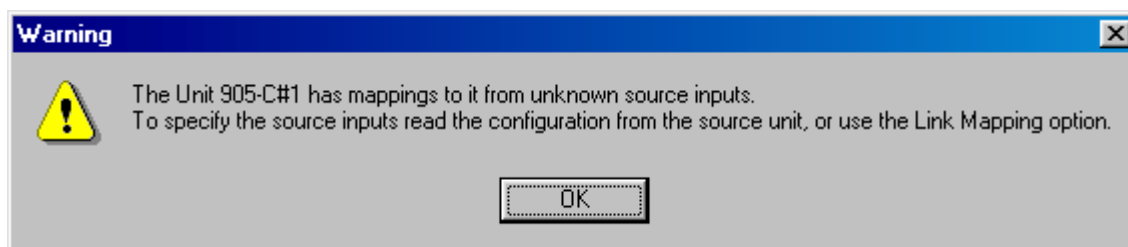

If you open the archived project first, and load into the archived project, then all mappings will display as normal - any mappings to/from the 905G will be over-written on the PC display by the loading process.

If you are unable to load into the archived project, then mappings to remote modules will be displayed, but mappings from remote inputs will be shown as “Unknown Mappings”.

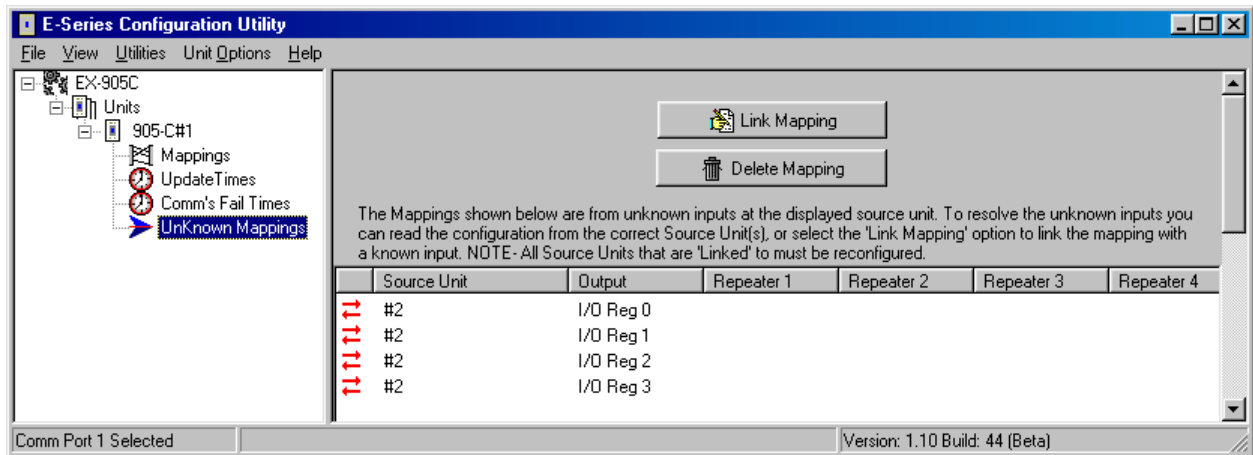

If you also load the configurations from the other remote modules in the system, then these unknown mappings will disappear as the program can determine where the remote inputs are. Alternately, you can select “Link Mapping” and manually enter the remote inputs.

Chapter 5

SPECIFICATIONS

General		
EMC approval	FCC Part 15A	
Radio standards	FCC Part 15.247	902 – 928 MHz, 1W
Housing	130 x 185 x 60mm DIN rail mount	Powder-coated, extruded aluminum
Terminal blocks	Removable	Suitable for 12 gauge / 2.5 mm ² conductors
LED indication	Power supply/OK, Active operation, digital I/O, Radio RX and TX, Serial RX and TX	
Operating Temperature	905U-G-MD1 905U-G-PR1 905U-G-ET1 905U-G-DE1 905U-G-M+1	-40 to 140 degF, -40 to 60 degC 30 to 140 degF, 0 to 60 degC 30 to 140 degF, 0 to 60 degC 30 to 140 degF, 0 to 60 degC 30 to 140 degF, 0 to 60 degC
Humidity	0 – 99% RH non-condensing	
Power Supply		
Battery supply	11.3 - 15.0 VDC	
AC supply	12 - 24 VAC, 50/60 Hz	
DC supply	9 - 30 VDC	
Battery Charging circuit	Included, suitable for 12V sealed lead acid batteries	Regulated to max 1.5 amp charging current
Normal Current Drain at 12VDC	905U-G-MD1 905U-G-PR1 905U-G-ET1	150 mA 270 mA 270 mA add 5mA per active I/O
Normal Current Drain at 24VDC	905U-G-MD1 905U-G-PR1 905U-G-ET1	90 mA 170 mA 170 mA add 3mA per active I/O
Radio transmitter inrush, additional to above	350mA @ 12VDC 250mA @ 24VDC	
Power fail status	Monitored	Can be transmitted to remote modules
Battery voltage	Monitored	Analog value can be transmitted Low voltage status can be transmitted
Radio Transceiver (905U)		
Spread spectrum	Frequency hopping	16 hop sequences x 100 channels

Frequency	USA/Canada Australia New Zealand	902 – 928 MHz 915 – 928 MHz 922 – 928 MHz
Transmission Power	1W	
Signal detect / RSSI	-120 to -40 dBm	
Expected line-of-sight range (subject to local conditions)	20 miles + @ 4W ERP 15 km + @ 1W ERP depending on local conditions	USA / Canada Australia / New Zealand Range may be extended by up to 5 intermediate modules as repeaters
Antenna Connector	Female SMA coaxial	
Data transmission rate	19200 baud	
Serial Ports		
RS232 Port	DB9 male DCE	RTS/CTS hardware signals provided
RS485 Port	2 pin terminal block	Typical distance 1 - 2 km
Data rate (bit/sec) - configurable	50, 75, 150, 300, 600, 1200, 2400, 4800, 9600, 19200	
Byte format	7 or 8 data bits	Stop/start/parity bits configurable
Profibus Port		
RS485 Port	Optically isolated	Autobaud detection 9.6 Kbit/sec – 12Mbit/sec
Ethernet Port		
RJ45	Transformer isolated	10/100 Mbit/sec
Digital I/O	Eight on-board I/O	3000V surge protection input, voltage free contact output, FET 30VDC 500mA

Chapter 6

DIAGNOSTICS

Before installing a new system, it is always best to set up the system on a bench to test the system configuration. It is always easier to detect problems when the modules are together.

After installation, test the radio paths, using the radio strength testing function described later in this section. Record the radio strength and background noise measurements for later reference (refer section 6.2.2 for this feature). If a later test shows that the radio path has changed, this may be the cause of a new problem.

6.1 Diagnostics Chart

The LED indicators on the 905G have the following meanings: -

INDICATOR	CONDITION	MEANING
OK	OFF continuously	Module power off, or module failure
	ON continuously	Normal Operation
RADIO TX	Flashes yellow	Radio transmitting
RADIO RX	Flashes green	Radio receiving good radio signal
	Flashes red	Radio receiving weak radio signal
SERIAL TX	Flashes yellow	Sending serial data
	Brief flash each second	Configuration Mode
SERIAL RX	Flashes green	Receiving serial data
	Flashes red	Serial RX buffer full
ACTIVE	OFF continuously	Start-up initializing sequence Diagnostic or configuration menu
	ON continuously	Module in active operation
	Flashes Yellow	Re-configuration required

The Ethernet and Profibus modules also have four diagnostic LED's on the end-plate - refer section 6.4.

6.2 Diagnostics Menu

The 905G provides both offline and online diagnostic features to assist with troubleshooting. The offline diagnostics disable both the radio and fieldbus interface drivers, and are only used for simple radio tests such as “RSSI Measurement” or “Tone Reversals”. The online diagnostics provide more powerful debugging features such as access to the internal I/O Registers and Radio Communications Monitoring while the module is running (i.e. online).

When the configured protocol driver uses the shared RS232/485 port (i.e. Modbus, DF1, or ELPRO Serial Driver), the online diagnostics must disable the serial protocol driver since the same serial port must be made available for diagnostics. However, the diagnostics still has full access to the radio network. For all other protocol drivers (Ethernet, Profibus, Modbus Plus, and DeviceNet), the serial port is already free and therefore online diagnostics can be used while the module is fully operational.

The module diagnostics can be accessed via any ‘terminal’ package (i.e. hyperterminal, procom), or via configuration software using the terminal available in the “Diagnostics” section. First, ensure that the 905G is connected to the PC using the RS232 configuration cable, and that the corresponding com port is selected. To access the terminal, select the 905G and press “Diagnostics”. Press the “terminal” button in the diagnostics window to open the terminal.

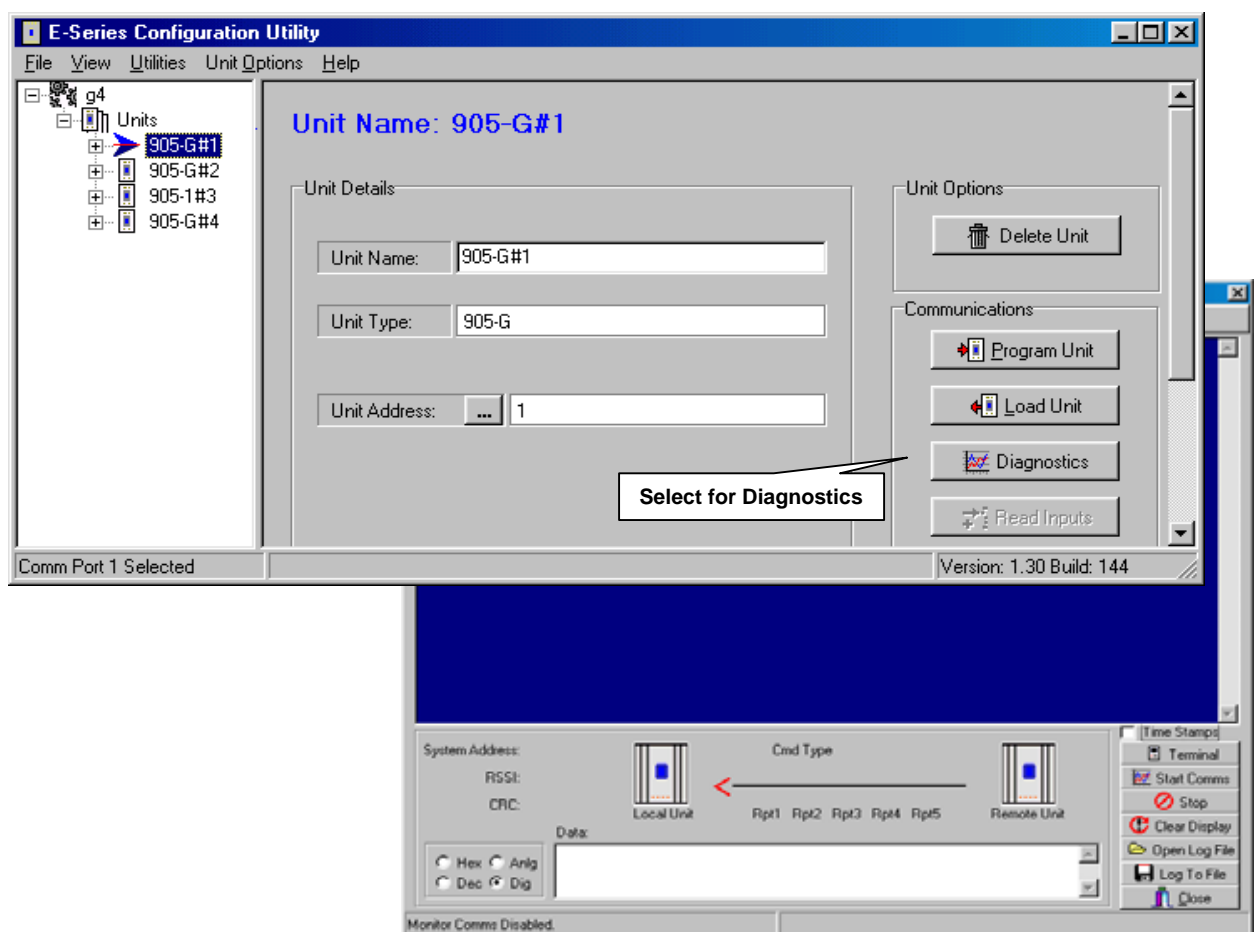

6.2.1 Offline Diagnostics:

The offline diagnostics menu disables the radio protocol driver *and* the fieldbus protocol driver. Before displaying the offline debug menu open and start the “terminal” window in configuration software (see above), or use any third party terminal package.

To display the offline diagnostics menu:

- Put the 905G into configuration mode by pressing the small pushbutton switch in the end plate of the module for 5 seconds (as per section 4.9) until the ACT led flashes - then release (then the ACT is off and the Serial TX LED flashes once every second);
- Type ‘m’ in the terminal window to get the off-line diagnostics menu.

The module will stop normal operations and a menu like the following will appear on the PC screen for all 905G versions.

Note: Options a), b) and d) are used in factory test and should not be selected.

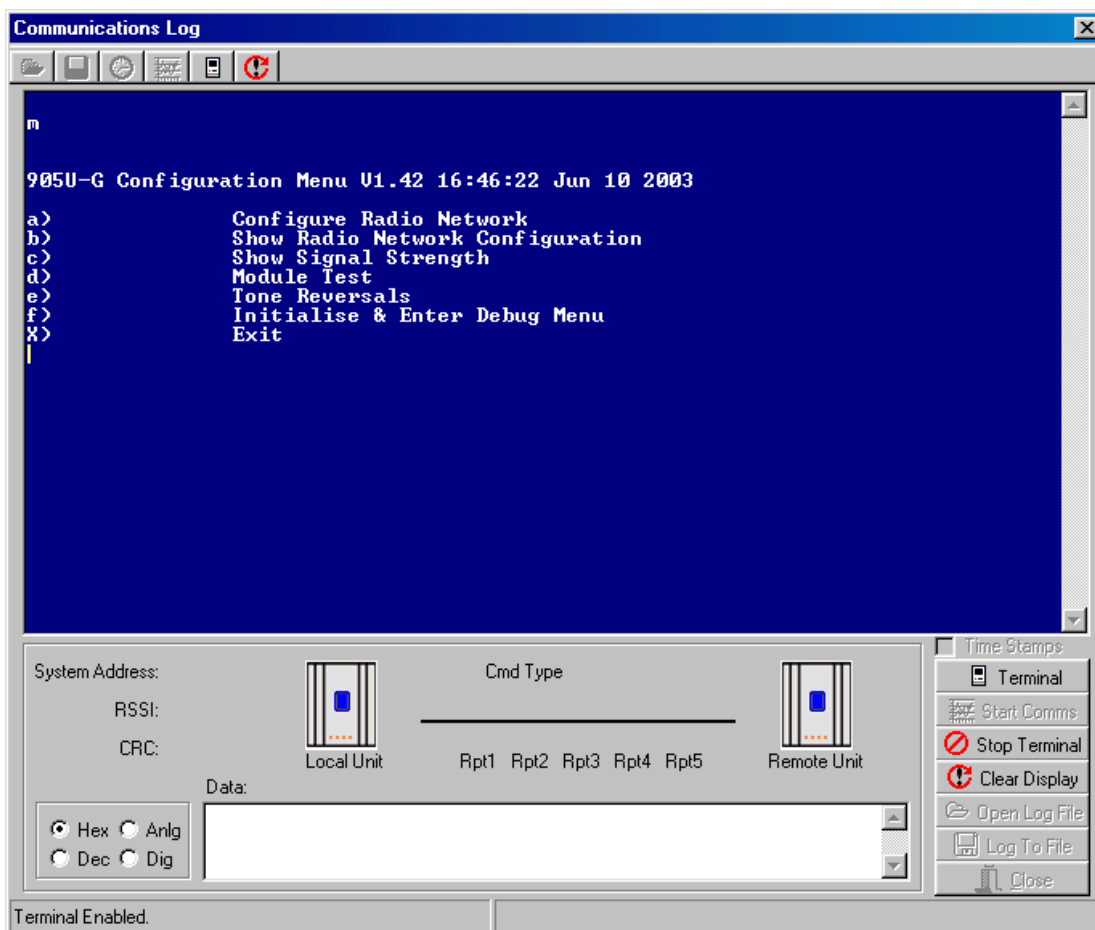

(c) Show Signal Strength

This option allows measurement of radio path between two locations. This is done by the display of the received radio signal strength at the connected 905G. With no transmitted signal from the other site, the display will show the strength of the background noise, which is normally between -100 and -130 dBm. At the other site, the transmitter may be turned on (select “e” at the other 905G, or “Tone Reversals” if the other module is a 905U). The display will now show the received radio signal from the other transmitter. For reliable operation, the average signal strength should be better than -95dBm (that is, -90dBm, not -100dBm) provided the average background noise is less than -105dBm (between -105 and -

130 dBm). If the average noise is greater than -105 , the difference between the noise level and the transmitter signal should be at least 10dB for reliable operation. For example, if the average noise level is -101 dBm, then a transmitter signal of better than -91 dBm is required for reliable operation.

Note the RSSI (received signal strength indication) of a received message is also stored in the database registers when the module is online - refer to section 2.5.1

e) Tone Reversals

If you select this option, the module will continuously transmit - you can use this feature for radio tests. Note that if you are powering the module from a battery only, the battery will be discharged quickly.

f) Initialise and Enter Debug Menu

This option will put the 905G in *online* debug mode. In online mode, the module will initialise the radio driver and go *online* to the radio network. Where possible, the fieldbus driver will also be initialised (i.e. for Ethernet, Profibus, Modbus Plus, and DeviceNet) – for Modbus, DF1, and ELPRO Serial Driver the fieldbus driver will be disabled so that the serial port can be used for diagnostics. Note: before going online, the 905G must complete any “startup polls” that are configured – this may take some time depending on how many polls are configured.

x) Exit

The module will restart via its normal power-up and initialization sequence, and resume its normal operation mode. Select “Stop Terminal” to shut down the terminal and close the com port.

6.2.2 Online Diagnostics

The online diagnostics menu enables the radio protocol driver *and* the fieldbus protocol driver (where possible) to provide online diagnostic information while the module is running. When the configured protocol driver uses the shared RS232/485 port (i.e. Modbus, DF1, or ELPRO Serial Driver), the online diagnostics must disable the serial protocol driver since the same serial port must be made available for diagnostics.

To access the online diagnostics menu, first connect to the “terminal” in configuration software (see above) or use any third party terminal package. Once the terminal is connected, display the menu using the following procedure:

- If the configured protocol driver uses the shared RS232/485 port (i.e. Modbus, DF1, or ELPRO Serial Driver), first enter the *offline* diagnostics menu (see 6.2.1 “Offline Diagnostics” above). From the offline menu, select option “f) Initialise and Enter debug Menu”. Once initialised the online menu will be displayed.
- For Ethernet, Profibus, Modbus Plus, or DeviceNet protocol drivers, simply press "Enter" to display the menu. If the module was previously in configuration mode or the offline menu, then first reset power to the module.

A menu like the following will appear on the PC screen for the all models, however Modbus/DF1 model will not have options h) through k).

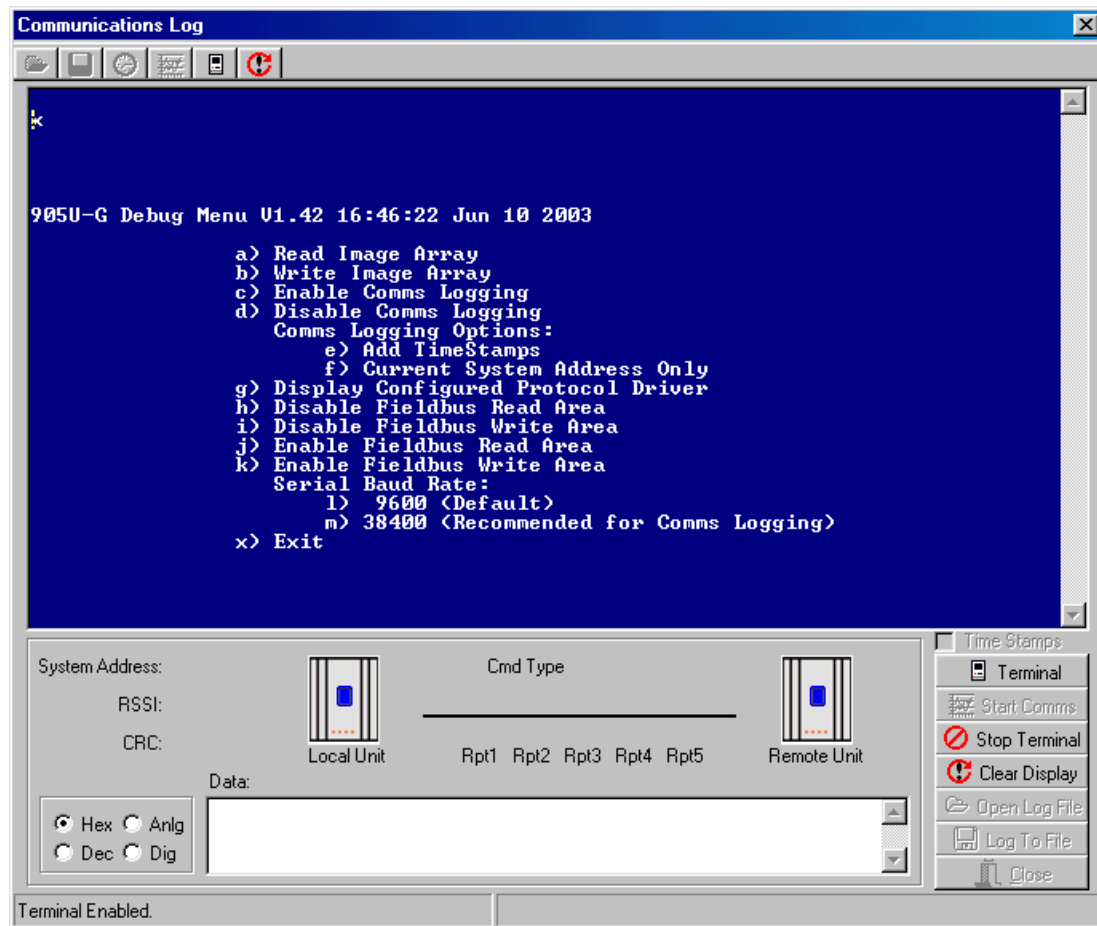

The online diagnostics menu is also referred to as the “Debug” menu. The Debug Menu allows the Radio Interface (I/O Registers) to be viewed and modified to confirm the operation of the radio network. These options may be used to check operation of outputs at remote sites, and to check the values of inputs reported from remote sites. When the protocol driver does *not* use the shared RS232/485 port (Ethernet, Profibus, DeviceNet, and Modbus Plus) data is also exchanged with the fieldbus and the I/O Registers according to the configured fieldbus mappings.

Option a) Read Image Array

Displays the I/O registers of the Radio Interface - the register values for a block of 50 registers are updated every 1 second. For example, to display the I/O Database value at locations 0 to 49.

Select a), then enter Location: 0

```

0 0x0000 0x0000 0x0000 0x0000 0x0000 0x0000 0x0000 0x0000 0x0000 0x0000
10 0x0000 0x0000 0x0000 0x0000 0x0000 0x0000 0x0000 0x0000 0x0000 0x0000
20 0x0000 0x0000 0x0000 0x0000 0x0000 0x0000 0x0000 0x0000 0x0000 0x0000
30 0x0000 0x0000 0x0000 0x0000 0x0000 0x0000 0x0000 0x0000 0x0000 0x0000
40 0x0000 0x0000 0x0000 0x0000 0x0000 0x0000 0x0000 0x0000 0x0000 0x0000

```

Note that I/O Image locations are specified in decimal, whereas register values are displayed and specified in hexadecimal. If you want the 905G to stop the host device writing values to the I/O database at the same time, then select option i) Disable Fieldbus Write Area.

Press “Enter” to go back to the menu.

Option b) Write Image Array

This option allows you to change the value of an I/O register in the Radio Interface.

To change the value of a register, select option b) write image array.

Enter the location, then the value to be written to the register – for example

b

Location: **12**

New Value: **0xFFFF**

Register values should always be written in hexadecimal format. If you want the 905G to stop the host device reading or writing values to the I/O database at the same time, then select option h) or i).

Options c), d) Enable/Disable Comms logging

These options allow logging and display of radio communications. Once enabled, the radio communications that are displayed is the radio traffic in raw format (i.e. the raw data frame for each received packet is displayed in hexadecimal format). To decode the meaning of each radio data packet, configuration software can be used to decode the data frames.

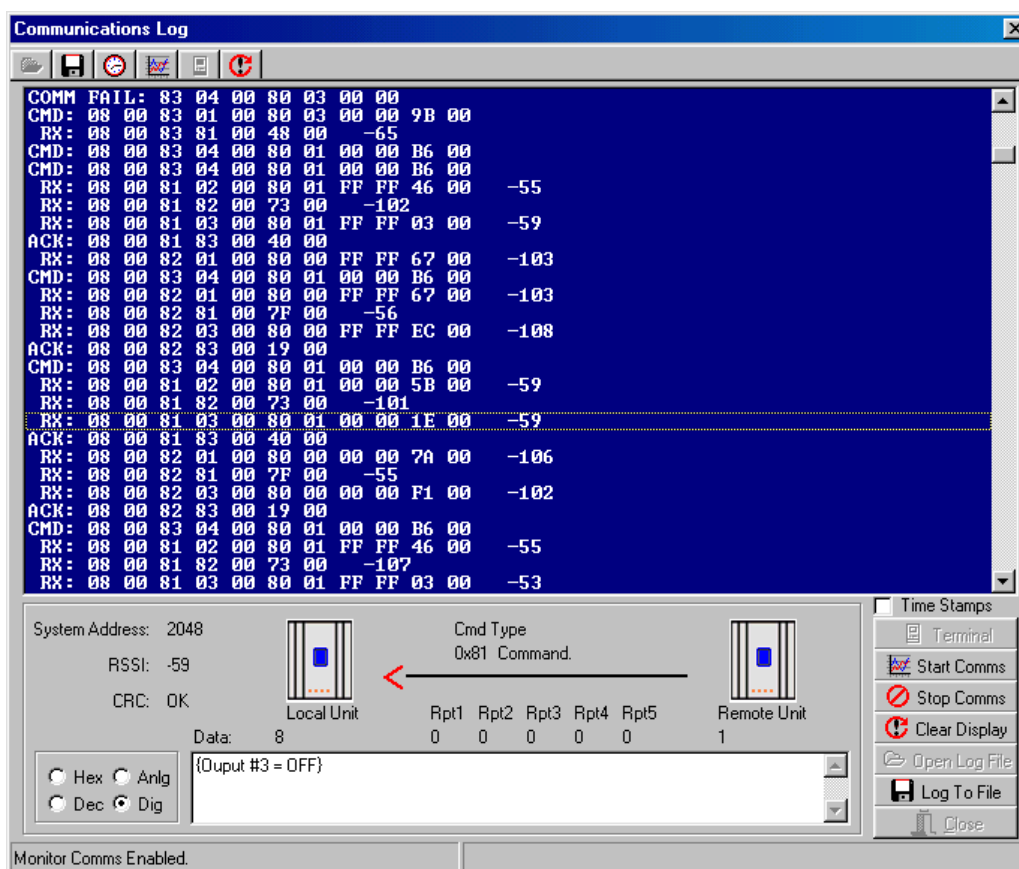

To decode the radio traffic using configuration software, first start communications logging by selecting option “c) Enable Comms Logging” from the debug menu. Next, in the diagnostics screen select ‘Stop Terminal’ and then ‘Start Comms’. Configuration software

now expects the 905G to be in monitor comms mode, and will decode all radio communications.

The display will show radio messages transmitted and received. Messages starting with RX are received messages, CMD are transmitted messages and ACK are acknowledgment messages. At the end of each received message is the RSSI (radio signal strength indication) in dBm.

If you select any message line with the mouse, information about the message will be displayed at the bottom of the screen - the system address, RSSI and CRC (error-check) status. The "text box" at the bottom middle of the screen decodes the message - that is, it decodes the message to display I/O channel and value. Note – Configuration software can only decode the message completely if the same configuration project corresponding to the system being monitored is open.

You can display the register values in Decimal by selecting "Dec" at the bottom of the screen. If you select "Dig", the values will be displayed as a 0 or 1 digital value (1 if the 16-bit value is greater than 50% - that is, the most significant bit is 1). If you select "Anlg", the value will be displayed as a 4-20mA range.

To stop the decoding of "comms logging", select the "Stop Comms" button. You should then also stop the 905G from outputting radio comms by pulling up the terminal menu (i.e. press "terminal" and then hit enter in the terminal screen) and selecting "d) Disable Comms Logging".

Option e) Add Time Stamps

This option in the debug menu will add a timestamp to each displayed radio message. The timestamp is based on the 905G internal real time clock. This option is normally used only if monitoring is done from a terminal package only, and configuration software is *not* being used to decode the communications.

When configuration software is being used to decode the radio comms (see above) time stamps can be added by selecting the "Time Stamps" checkbox. This will display the current time and date (according to the PC Clock) alongside each message. The "Comms log" can be saved to a file for future reference by selecting "Log to File".

Option f) Current System Address only

This option will ensure that only radio messages that have the same system address as the connected 905G are displayed. If you have another system with a different system address these messages will not be displayed if you choose this option. This option is useful where there is more than one system in the same area so that only the radio messages relevant to the desired system will be displayed.

Option g) Display Configured Protocol Driver

This option displays the configured Protocol Driver for this unit e.g.

Configured Protocol is: Ethernet TCP-IT

Option h, i, j, k) Enable/Disable Fieldbus Read/Write Area

(These options not available on the Modbus/DF1 version)

This option is used to halt data exchange between the Fieldbus Interface and the Radio Interface (I/O Registers). This is mainly used when trying to read or write image arrays. If the Fieldbus read area "h" is not disabled when trying to read or write to the I/O registers

then the value in the Fieldbus database will overwrite the I/O register and you may get an incorrect value.

When doing read/write image array and the module has been configured with Fieldbus mappings, you may need to disable the Fieldbus read area option h. This stops the Fieldbus database overwriting the radio database.

6.3 Ethernet Diagnostics

Read and Write image array can also be done via the Ethernet port by selecting 'Debug I/O Registers' from within the Ethernet Settings window in the configuration software. The IP address of the module must have previously been configured in the module - refer to section 4.8.2 for setting IP address.

To debug the registers you will need to select 'Connect' under Debug Options. The Green / Red box will indicate the Connected / Disconnected State. Once connected select "Read" and check "Continuous". The display option allows you to view the registers in different formats, and you can select which I/O register you want to view from the left-hand side of the screen.

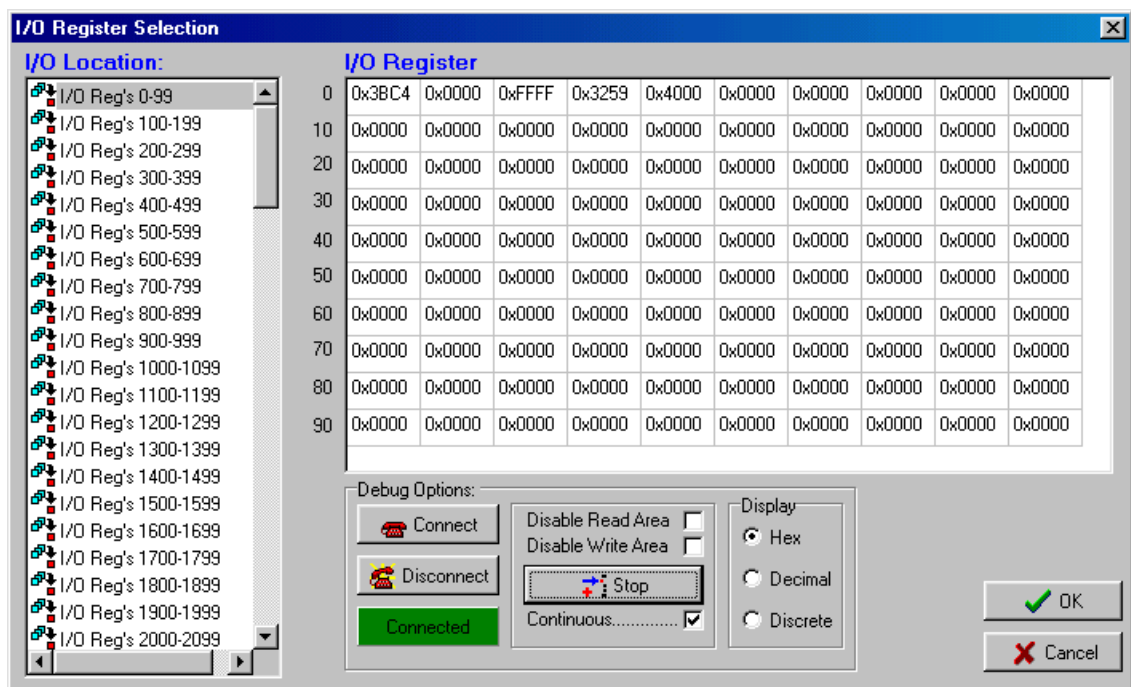
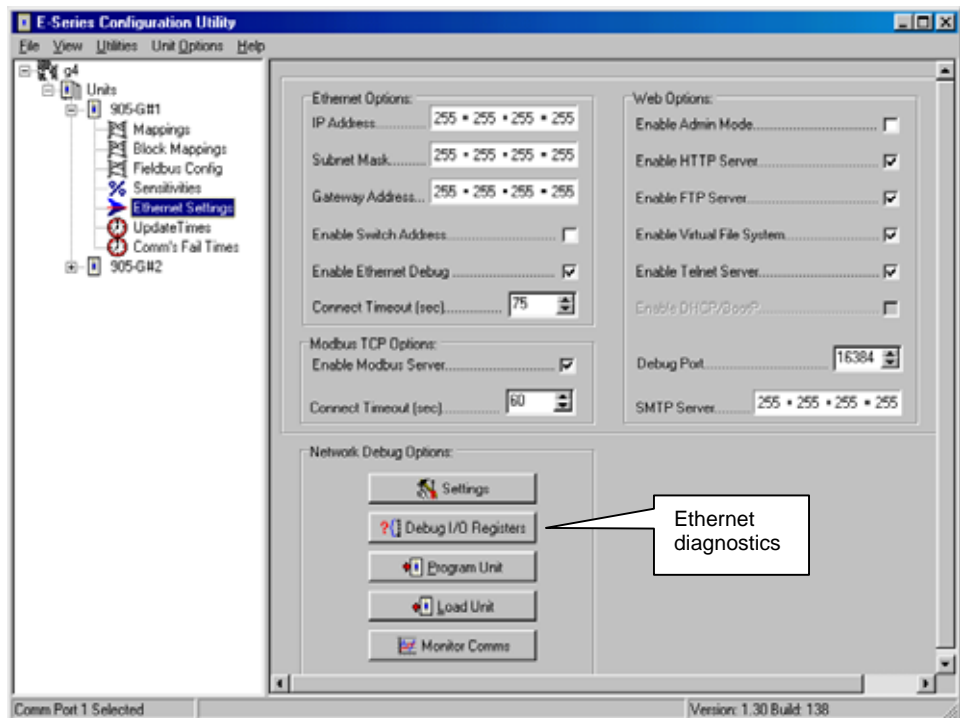

To write to a register double click with mouse on the register and a pop up box will appear as shown below. Enter value and press 'OK'.

You can disable the links between the I/O registers and the Ethernet interface by selecting "Disable Read Area" and "Disable Write Area" - if you do this, remember to re-enable before you leave the diagnostics screen.

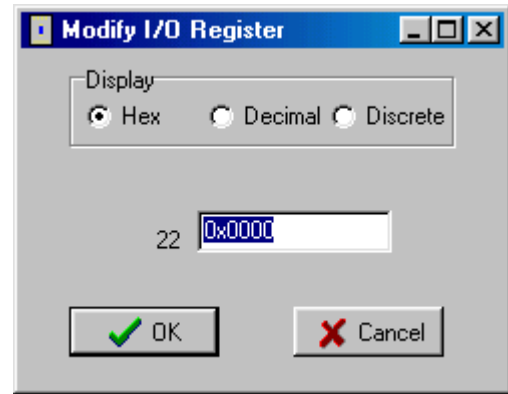

Settings

You can change your TCP Connection setting i.e. IP address and port.

Program / Load Unit

These options allow you to program and upload the configuration from the module via the Ethernet port. Must ensure the IP address has been set on the module before uploading the Configuration

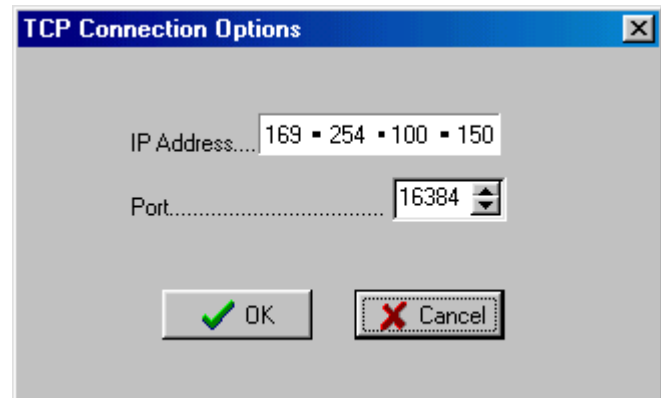

Monitor Comms

Configuration software also provides the option to monitor the radio network communications via the Ethernet port. This allows radio traffic to be monitored from any location where an Ethernet connection to the 905G can be established. Simply select 'Monitor Comms' from the Network Debug Options section of the Ethernet Settings page. Functionality is as per section 6.2.2c above.

6.4 Fieldbus Indicating LEDs

All 905G modules (*except* MD1) are equipped with four fieldbus indication LED's located in the module end plate, used for diagnostics purposes. The meaning of the LED's for each fieldbus is described below.



6.4.1 Ethernet Indicating LED's

Led No	Color	State	Description
1	Green	-	The Link led indicates that the module is connected to an Ethernet network.
2	Green	Off	No power applied to module.
2	Green	Steady	Device operating correctly.
2	Green	Flashing	Module has not been configured.
2	Red	Flashing	Minor recoverable fault has been detected.
2	Red	Steady	Major internal error has been detected.
2	Green/Red	Flashing	Power on self-test.
3	Green	Off	No power applied or no IP address has been assigned.
3	Green	Steady	Module has at least one Ethernet/IP connection established.
3	Green	Flashing	No Ethernet/IP connections to the module.
3	Red	Flashing	Connection timeout
3	Red	Steady	Duplicate IP address
3	Green/Red	Flashing	Power on self-test.
4	Green	Flashing	Flashes each time a packet is received or transmitted.

6.4.2 Profibus Slave Indicating LED's



LED No	Indication	Description
1	-	Not Used
2	Green	Module is On-Line and data exchange is possible.
2	Off	Module is not On-Line
3	Red	Module is Off-Line and no data exchange is possible.
3	Off	Module is not Off-Line
4	Flashing Red 1 Hz	Error in configuration: IN and/or OUT length set during initialization of the module is not equal to the length set during configuration of the network.
4	Flashing Red 2 Hz	Error in User Parameter data: The length/contents of the User Parameter data set during initialization of the module is not equal to the length/contents set during configuration of the network.
4	Flashing Red 4 Hz	Error in initialization of the Profibus communication ASIC.
4	Off	No diagnostics present

6.4.3 Profibus Master Indicating LED's



LED No	Indication	Description
1. Master Status	Green	Operate mode
	Green, flashing	Clear mode
	Red	Stop mode
	Off	Offline
2. Database Status	Green	Database OK
	Green, flashing	Database download in progress
	Red	Database invalid
	Off	No database downloaded
4. Communication Status	Green	Data exchange with all configured slaves
	Green, flashing	Data exchange with at least one configured slave
	Red	Bus control error (bus short circuit or configuration error)
	Off	No data exchange with any of the configured slaves
5. Token Hold	Green	The module has the token
	Off	The module does not have the token
All	Red	Fatal error

6.4.4 Modbus Plus Indicating LED's



LED No	Indication	Description
1	-	Not Used
2	Active Red	ERROR; This led indicates that communication is not OK.
3	Green	<p>MBP Active; This led flashes in different patterns depending on the module's health (see below).</p> <p>Flash every 160 ms; on 80ms, then off 80 ms. Normal operation, the node is receiving and passing token.</p> <p>Flash every 1 s: This node is in MONITOR_OFFLINE state.</p> <p>2 flashes, on 160 ms, then off 480 ms: This node is in MAC_IDLE never-getting-token state.</p> <p>3 flashes, on 160 ms, off 240 ms and finally off 1.6 s: This node is not hearing any other nodes.</p> <p>4 flashes, on 160 ms, then off 240 ms and finally off 1.2 s: This node has detected duplicate node address.</p>
4	Active Green	MBP Init; This LED indicates if the fieldbus interface is initialized

6.4.5 DeviceNet Indicating LED's:



Led No	Color	State	Description
1	-	-	Reserved for future use
2	-	Off	Not powered / Not online
2	Green	Steady	Link OK, On line, Connected
2	Green	Flashing	On line, Not connected
2	Red	Flashing	Connection timeout
2	Red	Steady	Critical link failure
2	Green/Red	Flashing	Power on self-test.
3	-	Off	No power to device
3	Green	Steady	Device operational
3	Green	Flashing	Data size bigger than configured
3	Red	Flashing	Minor fault
3	Red	Steady	Unrecoverable fault
3	Green/Red	Flashing	Power on self-test.
4	-	-	Reserved for future use

Chapter 7

WARRANTY

We are pleased that you have purchased this product.

ELPRO products are warranted to be free from manufacturing defects for a period of 2 years from the effective date of purchase. The effective date of purchase is decided solely by ELPRO Technologies.

This warranty does not extend to:

- failures caused by the operation of the equipment outside the particular product's specification, or
- use of the module not in accordance with this User Manual, or
- abuse, misuse, neglect or damage by external causes, or

repairs, alterations, or modifications undertaken other than by an authorized Service Agent.

ELPRO's liability under this warranty is limited to the replacement or repair of the product. This warranty is in lieu of and exclusive of all other warranties. This warranty does not indemnify the purchaser of products for any consequential claim for damages or loss of operations or profits and ELPRO is not liable for any consequential damages or loss of operations or profits resulting from the use of these products. ELPRO is not liable for damages, losses, costs, injury or harm incurred as a consequence of any representations, warranties or conditions made by ELPRO or its representatives or by any other party, except as expressed solely in this document.

Full product specifications and maintenance instructions are available from your Service Agent, your source of purchase, or from the master distributor in your country upon request and should be noted if you are in any doubt about the operating environment for your equipment purchase

In the unlikely event of your purchase being faulty, your warranty extends to free repair or replacement of the faulty unit, after its receipt at the master distributor in your country. Our warranty does not include transport or insurance charges relating to a warranty claim.

Should you wish to make a warranty claim, or obtain service, please forward the module to the nearest authorized Service Agent along with proof of purchase. For details of authorized Service Agents, contact your sales distributor.

Appendix 1 Status Registers

I/O Status Registers 5000 - 9499

Bit	Information	Meaning										
15	Communications failure	For inputs, this bit is set ("on") if no message has been received from the remote address within the timeout period configured for this input. The bit is reset ("off") when a message is received. For outputs, this bit is set ("on") if transmission to the remote was unsuccessful after five attempts. The bit is reset ("off") when a message is transmitted successfully. This bit may also be set if the Disable Output Transmissions on Comms Fail option is selected - see the Radio Comms Failure section.										
14	Start-up status	For inputs, this bit remains set ("on") following start-up until a message has been received for this input to give an initial input value. For outputs, this bit remains set ("on") following start-up until the 905C sends the first radio message for this output to the remote address.										
13	Input / Output status	This bit is set ("on") if this I/O point has been configured as an input.										
12	Active status	This bit is set ("on") if the register has been configured as an I/O point.										
11-10	Timer Units	This field determines whether the timer counts down every 10 seconds, every minute, or every hour. <table border="0"> <tr> <td>Timer Units</td> <td>Timer timebase</td> </tr> <tr> <td>00</td> <td>Every 10 seconds</td> </tr> <tr> <td>01</td> <td>Every minute</td> </tr> <tr> <td>10</td> <td>Every Hour</td> </tr> <tr> <td>11</td> <td>Every Hour</td> </tr> </table>	Timer Units	Timer timebase	00	Every 10 seconds	01	Every minute	10	Every Hour	11	Every Hour
Timer Units	Timer timebase											
00	Every 10 seconds											
01	Every minute											
10	Every Hour											
11	Every Hour											
9 - 0	Timer	For inputs, the timer value is set to the configured comms fail time for the input whenever a message has been received for this input. The timer value will decrease until another message is received. When the timer value reaches zero, the comms fail status is set. If the configured comms fail time is zero, then the comms fail status for this input is never set. For outputs, the timer value is set to the configured update time for the output whenever a message is transmitted by the 905C to the remote address. The timer value decreases. When the timer value reaches zero, another update message is transmitted to the remote address. If the configured update time is zero, no update messages are transmitted for this output.										

Block Message Status Registers 9500 - 9999

Bit	Information	Meaning
15	Communications failure	For read commands – Read Bits and Read Words – This bit is set if no response is received to the read command after a timeout, or if a communication fail response is received to a read. For Write Commands this bit is set if a communication failure response is received to the write command. For a Poll command, this bit should not be set.
14	Startup	This bit is set initially, and remains set until the first time the command executes.
13	Force	*To force the command to happen immediately regardless of the current timer value, write a ‘1’ to this bit.
12	Waiting	This bit is set when the command is active. For Write commands, the command delays before sending to see if any more changes occur. For Read commands, the command delays while waiting for a response from the remote device.
11-0	Timer	When the Waiting bit is clear, this field is either zero, or contains the time (in seconds) until the command next becomes active. If this field is zero, the field will be loaded with the configured delay value at the next update time. When the Waiting bit is set, and the command is a read command, this field contains the time in seconds, within which a reply is expected. If no reply is received within this time, the Communications failure bit is set. When the Waiting bit is set, and the command is a write command, the field contains the time, in seconds before the write command is transmitted.

Using the Force Bit:

*** Firmware versions prior to 1.50:**

If Bit 13 is set to ‘1’, then the associated mapping is triggered. When the radio message is sent, the 905G automatically turns Bit 13 “off” again - ready for the host device to trigger the mapping again.

*** Firmware version 1.50 and later:**

Only Bit 13 of registers 9500 – 9999 may be altered by a host device (i.e. via the fieldbus interface). For 905G modules with firmware versions later than 1.50, the setting of registers 9500 – 9999 must follow the new change-of-state algorithm. The *Force* bit will only be activated on a transition from 0 – 1. For example to force the corresponding block mapping, first set the Force bit to ‘0’, then set the value of the Force bit to ‘1’ (i.e. by always first writing the value 0 this ensures that the change-of-state from 0 will be detected). Values must be held (i.e. not change) for approx. 200msec to be detected.

Appendix 2

IT Functionality

905U-G-ET1 Ethernet module only

Filesystem

The filesystem is a fixed-size storage area with a hierarchical directory structure. Any user- or application data can be stored in files within the filesystem. Files can be grouped in directories for increased readability.

The filesystem features two security levels. Depending on security level, different users can have access to different files and directories. The filesystem can be accessed via FTP, Telnet, and HTTP.

- **Case Sensitivity**

The file system is case sensitive. This means that the file 'ELPRO.txt' is not identical to the file 'elpro.TXT'.

- **Filename / Pathname length**

Filenames can be a maximum of 48 characters long. Pathnames can be 256 characters in total, filename included.

- **File size**

File size is not restricted. However, the size cannot exceed the space available in the file system.

- **Free space**

Approximately 1.4MB non-volatile (FLASH).

Security

The file system features two security levels; Admin and Normal. Security level is set at a per user basis, or globally via setting Admin Mode in configuration software Ethernet Settings.

- **Normal Mode**

This mode is recommended for normal operation, so that web pages and other settings are protected from FTP and Telnet access. In this mode, the FTP and Telnet servers are enabled *only* if there is a subdirectory called "\user". When a normal user connects via FTP or Telnet, this directory will be their root directory. The user will not be able to access files outside this directory and its subdirectories.

If user/password protection for FTP and Telnet is required in normal mode, a file called "sys_pswd.cfg" must be placed in the directory "\user\pswd\". Files in this directory cannot be accessed from a web browser. If Admin Mode has not been enabled by configuration software and a valid admin password file (See "System Files") is found, the module will operate in this mode (i.e. an admin password file with at least one entry *must* exist, *and* the "\user" directory *must* exist to enable this mode).

- **Admin Mode**

Admin users have full access to the filesystem through FTP and Telnet. This enables the user to access areas of the filesystem that are restricted or inaccessible in Normal mode. The Admin user accounts are defined in the file ‘ad_pswd.cfg’.

If no admin password file (See “System Files”) is found or Admin Mode is set by configuration software, the module will run in Admin Mode; i.e. all users will have Admin access rights. No login is needed for Telnet, and the FTP server accepts any username/password combination. Admin Mode is primarily intended for product configuration and testing.

Files within the file system can be protected from web (i.e. HTTP) access through username/password authorization, see sections below on “System Files” and “web_accs.cfg”. It is also possible to configure which IP addresses and what protocols are allowed to connect to the module, see “ip_accs.cfg”.

System Files

The module uses system files for configuration purposes (see file system “Structure” below). In most cases these files have the file extension ‘.cfg’ and must be created or edited by the user to achieve the desired configuration. The system files are ASCII (text) files and can be edited with any text editor, or copied/moved to/from the file system using FTP or Telnet. Depending on security settings, the files may be inaccessible for normal users. Generally, the module has to be restarted in order for any changes in these files to have effect.

Note: It is very important to follow the exact syntax specifications for each configuration file, otherwise the module might have problems interpreting it, which can result in a faulty or non-expected behaviour.

ad_pswd.cfg & sys_pswd.cfg

User/password information for FTP and Telnet is stored in the files ‘sys_pswd.cfg’ (Normal users) and ‘ad_pswd.cfg’ (Admin users) – see “Security” above. These files must be placed in ‘\user\pswd’ and ‘\pswd\’ respectively. These directories are protected from web browser access.

The file format is the following:

```
User1:password1
User2:password2
...
User3:password3
```

Example:

```
ELPRO:905G
```

In this example, the username is ‘ELPRO’, and the password is ‘905G’. If no ‘:’ is present, the password will be equal to the username.

web_accs.cfg

To protect a directory from web access, a file called ‘web_accs.cfg’ must be placed in the directory to protect. This file shall contain a list of users that are allowed to browse the protected directory and its subdirectories. Multiple of these password files

may be present in the system, allowing different users to access different files and directories.

The file format is the same as for the 'ad_pswd.cfg' and 'sys_pswd.cfg' files, except that the optional parameter 'AuthName' can be added. The value of this parameter will be presented in the login window. If it is not given, the requested file/pathname will be presented instead.

File format:

```
User:Password
[AuthName]
(Message goes here)
```

The contents of this file can be redirected by placing the line '[File path]' on the first row, followed by a list of password files.

Example:

```
[File path]
\user\pswd\my_passwords\web_pswd.cfg
```

If any errors in the format of these files are detected the user/password protection will be ignored

ip_accs.cfg

It is possible to configure which IP addresses and what protocols that are allowed to connect to the module. This information is stored in the file 'ip_accs.cfg'. The file contains one or several of the headers below.

```
[Web]
[FTP]
[Telnet]
[Modbus/TCP]
[Ethernet/IP]
[All]
```

Under each header the allowed IP addresses are written. The wildcard '*' can be used to allow series of IP addresses. If a protocol header is not given, the system will use the configuration set below the header 'All'. If the 'All' header is not given, the protocol will not accept any connections.

Example:

```
[Web]
10.10.12.*
10.10.13.*
[FTP]
10.10.12.*
[Telnet]
10.10.12.*
[All]
*.*.*.*
```

The above example will allow all IP addresses beginning with 10.10.12 to access all protocols in the module. Addresses beginning with 10.10.13 will be able to access the web server, but not the FTP and Telnet servers. The Modbus/TCP and Ethernet/IP servers will accept connections from any IP address.

The contents of this file can be redirected by placing the line '[File path]' on the first row, and a file path on the second. This procedure is exactly the same as with the system file "web_accs.cfg" (see above).

telwel.cfg

The default Telnet welcome message can be changed by creating this file. It shall contain the new welcome message in ASCII form. The contents of this file can be redirected by placing the line '[File path]' on the first row, and a file path on the second.

Example:

```
[File path]
\my_settings\telnet_welcome_message.txt
```

ethcfg.cfg

This file contains the network configuration and is read by the module at start up. The settings in this file may be affected by configuration software and SSI commands. The format of the file is the following:

```
[IP address]
192.168.0.150
[Subnet mask]
255.255.255.0
[Gateway address]
192.168.0.1
[DHCP/BOOTP]
OFF (allowable values are "ON" and "OFF")
[Speed]
Auto (allowable values are "Auto", "100", or "10")
[Duplex]
Auto (allowable values are "Auto", "Full", or "Half")
[SMTP address]
0.0.0.0
[SMTP username]
username
[SMTP password]
password
[DNS1 address] (Primary DNS)
0.0.0.0
[DNS2 address] (Secondary DNS)
0.0.0.0
[Domain name]
elprotech.com
[Host name]
ELPRO
```

NOTE: In the current firmware implementation "IP Address", "Subnet Mask", "Gateway Address", and "SMTP Address" will *always* be overridden by the values used in configuration software (i.e. those values cannot be set by writing to this file).

The contents of this file can be redirected by placing the line '[File path]' on the first row, and a file path on the second. This procedure is exactly the same as with the system file "ip_accs.cfg" (see above). For example, redirecting the contents of this file to the "\user" directory would allow "Normal Mode" users to have access to this file.

Structure

The figure below illustrates the structure of the file system, where the system files are located, and which areas Normal/Admin users can access. The files and directory structure must be created by the user using FTP or Telnet. The required .cfg file structures are outlined in the 'System Files' section below.

Root directory for Admin users

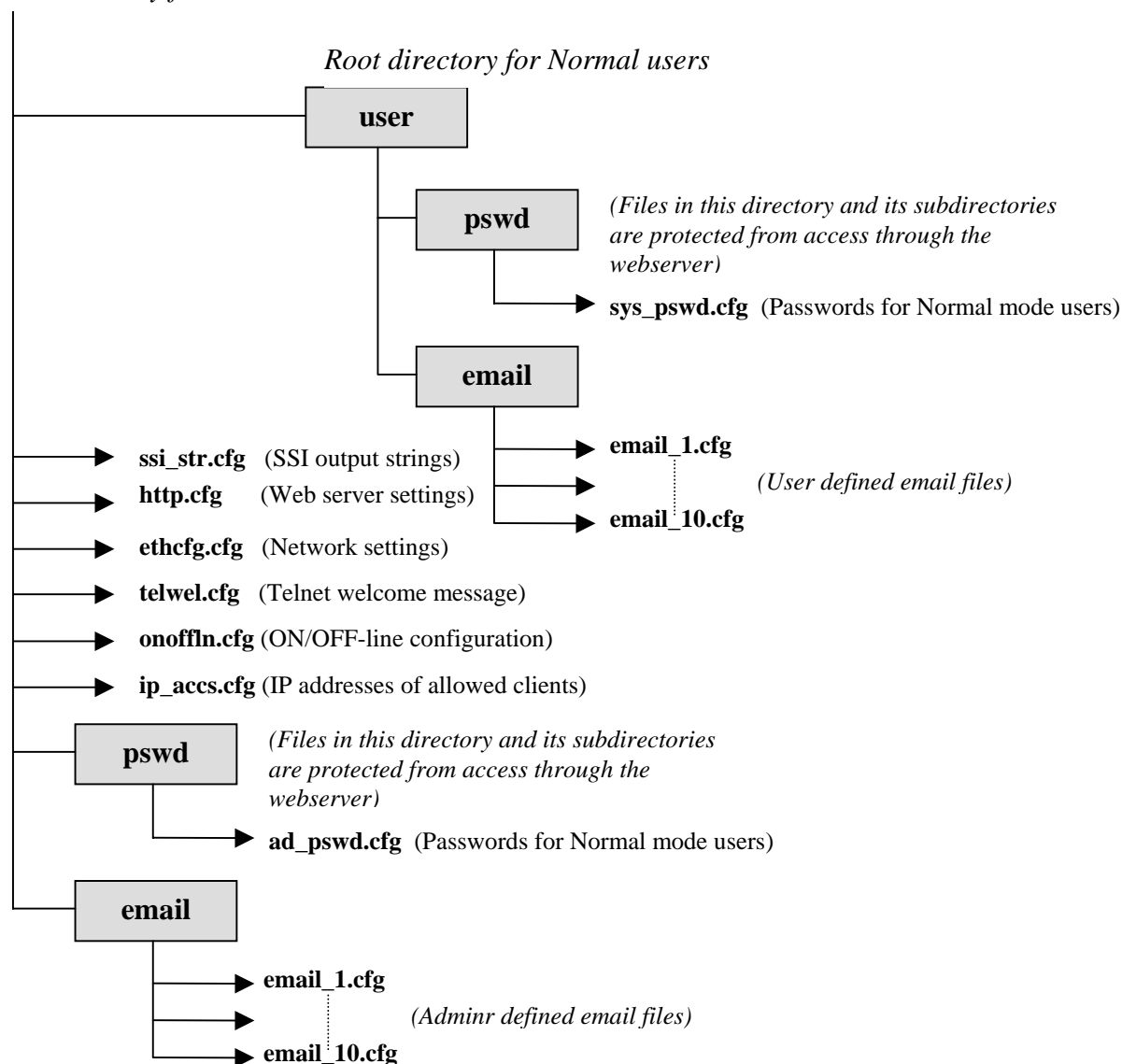

Virtual File System

The module also contains a virtual file system containing a set of files used to build the default configuration webpage. The virtual file system can be overwritten or disabled, but not erased; A file with the same name in the file system replaces the file in the virtual file system until it is removed. The entire virtual file system can be disabled using configuration software on the Ethernet Settings page.

Replacing the virtual files makes it possible to for example replace the default logo by uploading a new logo named '\logo.jpg'. It is also possible to make links from a web page to the virtual configuration page. In that case the link shall point to '\config.htm'.

The virtual file system contains the following files:

\index.htm - Points to the contents of config.htm

\config.htm	- Configuration frame page
\configform.htm	- Configuration form page
\configform2.htm	- Configuration form page
\store.htm	- Configuration store page
\logo.jpg	- HMS logo
\configuration.gif	- Configuration picture
\boarder.bg.gif	- picture
\boarder_m_bg.gif	- picture

FTP Server

It is possible to upload/download files to/from the file system using a standard FTP client. Depending on security settings, different parts of the filesystem can be accessed by the user (see Security above). Internet Explorer within the Windows Operating System, for example, may also operate as an FTP Client simply by preceding the address in the address bar with “ftp:” instead of “http:”

The FTP Server can be disabled via configuration software on the Ethernet Settings page.

Server Side Include (SSI) Functionality

The SSI functionality makes it possible to display or alter I/O data and configuration settings on a web page. It is also possible to use SSI functions in email messages (see “SSI in Email Messages”). Since this functionality allows reading/writing of I/O values in the Fieldbus Interface, some of the functions described below will use an “offset” parameter to specify the I/O Location within the Fieldbus Interface. It should be noted that the “offset” parameter will *always* refer to a byte-addressed offset from the start of the Fieldbus Interface (i.e. the “Address Mode” in configuration software should be set to “Byte” and the “Modbus TCP Address Mode” option should be disabled – see 4.8 Fieldbus Configuration).

Functions

DisplayIP

Syntax: <?--#exec cmd_argument='DisplayIP'-->

This function returns the currently used IP address.

DisplaySubnet

Syntax: <?--#exec cmd_argument='DisplaySubnet'-->

This function returns the currently used Subnet mask

DisplayGateway

Syntax: <?--#exec cmd_argument='DisplayGateway'-->

This function returns the currently used Gateway address

DisplayDNS1

Syntax: <?--#exec cmd_argument='DisplayDNS1'-->

This function returns the address of the primary DNS server.

DisplayDNS2

Syntax: <?--#exec cmd_argument='DisplayDNS2'-->

This function returns the address of the secondary DNS server

DisplayHostName

Syntax: <?--#exec cmd_argument='DisplayHostName'-->

This function returns the hostname.

DisplayDomainName

Syntax: <?--#exec cmd_argument='DisplayDomainName'-->

This function returns the default domain name.

DisplayDhcpState

Syntax:

<?--#exec cmd_argument='DisplayDhcpState("Output when ON", "Output when OFF")'-->

This function returns whether DHCP/BootP is enabled or disabled.

DisplayDhcpSupport

Syntax: <?--#exec cmd_argument='DisplayDhcpSupport("Arg1", "Arg2")'-->

DHCP support can be disabled using configuration software. This function returns 'Arg1' if it's enabled and 'Arg2' if it's disabled.

DisplayEmailServer

Syntax: <?--#exec cmd:argument='DisplayEmailServer'-->

This function returns the currently used SMTP server address.

DipslaySMTPUser

Syntax: <?--#exec cmd:argument='DisplaySMTPUser'-->

This function returns the username used for SMTP authentication.

DipslaySMTPPwd

Syntax: <?--#exec cmd:argument='DisplaySMTPPwd'-->

This function returns the password used for SMTP authentication.

GetText *(Note - This function cannot be used within email messages)*

Syntax:

<?--#exec cmd arbgument='GetText("ObjName", OutWriteString (offset), n)'-->

This SSI function gets the text from an object and stores it in the OUT area.

ObjName - Name of object.

offset - Specifies the offset from the beginning of the OUT area (i.e. Fieldbus Location).

n - Specifies maximum number of characters to read (Optional)

printf

Syntax: <?--#exec cmd_argument='printf("String to write", Arg1, Arg2, ..., ArgN)'-->

This SSI function includes a formatted string, which may contain data from the Fieldbus IN/OUT area, on a web page. The formatting of the string is equal to the standard C function printf().

Like the standard C function printf() the "String to write" for this SSI function contains two types of objects: Ordinary characters, which are copied to the output stream, and conversion specifications, each of which causes conversion and printing of the next successive argument to printf. Each conversion specification begins with the character % and ends with a conversion character. Between the % and the conversion character there may be, in order:

- Flags (in any order), which modify the specification:
 - which specifies left adjustment of the converted argument in its field.
 - + which specifies that the number will always be printed with a sign (space) if the first character is not a sign, a space will be prefixed.
 - 0 for numeric conversions, specifies padding to the field with leading zeroes.
 - # which specifies an alternate output form. For o, the first digit will be zero. For x or X, 0x or 0X will be prefixed to a non-zero result. For e, E, f, g and G, the output will always have a decimal point; for g and G, trailing zeros will not be removed.
- A number specifying a minimum field width. The converted argument will be printed in a field at least this wide, and wider if necessary. If the converted argument has fewer characters than the field width it will be padded on the left (or right, if left adjustment has been requested) to make up the field width. The padding character is normally space, but can be 0 if the zero padding flag is present.
- A period, which separates the field width from the precision.
- A number, the precision, that specifies the maximum number of characters to be printed from a string, or the number of digits to be printed after the decimal point for e, E, or F conversions, or the number of significant digits for g or G conversion, or the minimum number of digits to be printed for an integer (leading 0s will be added to make up the necessary width)
- A length modifier h, l, or L. "h" Indicates that the corresponding argument is to be printed as a short or unsigned short; "l" or "L" indicates a long or unsigned long.

The conversion characters and their meanings are shown below. If the character after the % is not a conversion character, the behaviour is undefined.

| Char-acter | Argument type | Converted to |
|------------|---------------|--|
| d, i | byte, word | decimal notation (For signed representation. Use signed argument) |
| o | byte, word | octal notation (without a leading zero). |
| x, X | byte, word | hexadecimal notation (without a leading 0x or 0X), using abcdef for 0x or ABCDEF for 0X. |
| u | byte, word | decimal notation. |
| c | byte, word | single character, after conversion to unsigned char. |
| s | char* | characters from the string are printed until a '\0' (i.e. NULL) is reached or until the number of characters indicated by the precision have been printed |
| f | float | decimal notation of the form [-]mmm.ddd, where the number of d's is specified by the precision. The default precision is 6; a precision of 0 suppresses the decimal point. |
| e, E | float | decimal notation of the form [-]m.ddddd e+-xx or [-]m.dddddE+-xx, where the number of d's specified by the precision. The default precision is 6; a precision of 0 suppresses the decimal point. |
| g, G | | %e or %E is used if the exponent is less than -4 or greater than or equal to the precision; otherwise %f is used. Trailing zeros and trailing decimal point are not printed. |
| % | - | print a % |

The arguments that can be passed to the SSI function *printf* are:

| Argument | Description |
|--------------------------------|--|
| InReadSByte(<i>offset</i>) | Reads a signed byte from position <i>offset</i> in the IN area |
| InReadUByte(<i>offset</i>) | Reads an unsigned byte from position <i>offset</i> in the IN area |
| InReadSWord(<i>offset</i>) | Reads a signed word (short) from position <i>offset</i> in the IN area |
| InReadUWord(<i>offset</i>) | Reads an unsigned word (short) from position <i>offset</i> in the IN area |
| InReadSLong(<i>offset</i>) | Reads a signed longword (long) from position <i>offset</i> in the IN area |
| InReadULong(<i>offset</i>) | Reads an unsigned longword (long) from position <i>offset</i> in the IN area |
| InReadString(<i>offset</i>) | Reads a string (char*) from position <i>offset</i> in the IN area |
| InReadFloat(<i>offset</i>) | Reads a floating point (float) value from position <i>offset</i> in the IN area |
| OutReadSByte(<i>offset</i>) | Reads a signed byte from position <i>offset</i> in the OUT area |
| OutReadUByte(<i>offset</i>) | Reads an unsigned byte from position <i>offset</i> in the OUT area |
| OutReadSWord(<i>offset</i>) | Reads a signed word (short) from position <i>offset</i> in the OUT area |
| OutReadUWord(<i>offset</i>) | Reads an unsigned word (short) from position <i>offset</i> in the OUT area |
| OutReadSLong(<i>offset</i>) | Reads a signed longword (long) from position <i>offset</i> in the OUT area |
| OutReadULong(<i>offset</i>) | Reads an unsigned longword (long) from position <i>offset</i> in the OUT area |
| OutReadString(<i>offset</i>) | Reads a NULL terminated string (char*) from position <i>offset</i> in the OUT area |
| OutReadFloat(<i>offset</i>) | Reads a floating point (float) value from position <i>offset</i> in the OUT area |

scanf

Syntax:

```
<?--#exec cmd_argument='scanf( "ObjName", "format", Arg1, ..., ArgN), ErrVal1, ..., ErrvalN'->
```

This SSI function reads a string passed from an object in a HTML form, interprets the string according to the specification in format, and stores the result in the OUT area according to the passed arguments. The formatting of the string is equal to the standard C function call scanf()

ObjName - The name of the object with the passed data string

format - Specifies how the passed string shall be formatted

Arg1 - ArgN - Specifies where to write the data

ErrVal1 -ErrvalN - Optional; specifies the value/string to write in case of an error.

| Character | Input data, Argument Type |
|-----------|---|
| d | Decimal number; byte, short |
| i | Number, byte, short. The number may be in octal (leading 0(zero)) or hexadecimal (leading 0x or 0X) |
| o | Octal number (with or without leading zero); byte, short |
| u | Unsigned decimal number; unsigned byte, unsigned short |
| x | Hexadecimal number (with or without leading 0x or 0X); byte, short |
| c | Characters; char*. The next input characters (default 1) are placed at the indicated spot. The normal skip over white space is suppressed; to read the next non-white space character, use %1s. |
| s | Character string (not quoted); char*, pointing to an array of characters large enough for the string and a terminating "\0" that will be added. |
| e, f, g | Floating-point number with optional sign, optional decimal point and optional exponent; float* |
| % | Literal %; no assignment is made. |

The conversion characters d, i, o, u and x may be preceded by l (small case L) to indicate that a pointer to 'long' appears in the argument list rather than a 'byte' or a 'short'

The arguments that can be passed to the SSI function scanf are:

| Argument | Description |
|---------------------------------|---|
| OutWriteByte(<i>offset</i>) | Writes a byte to position <i>offset</i> in the OUT area |
| OutWriteWord(<i>offset</i>) | Writes a word (short) to position <i>offset</i> in the OUT area |
| OutWriteLong(<i>offset</i>) | Writes a long to position <i>offset</i> in the OUT area |
| OutWriteString(<i>offset</i>) | Writes a string to position <i>offset</i> in the OUT area |
| OutWriteFlost(<i>offset</i>) | Writes a floating point (float) value to position <i>offset</i> in the OUT area |

IncludeFile

Syntax: <?--#exec cmd_argument='IncludeFile("File name")'-->

This SSI function includes the contents of a file on a web page.

Default output:

Success - <File content>

Failure - Failed to open <filename>

SaveToFile

Syntax:

<?--#exec cmd_argument='SaveToFile("File name", "Separator", [Append|Overwrite])'-->

This SSI function saves the contents of a passed form to a file. The passed name/value pair will be written to the file "File name" separated by the "Separator" string. The contents can either be Appended to the file or overwrite the current content of the file.

Default output:

| | |
|---------|-----------------------|
| Success | - Form saved to file |
| Failure | - Failed to save form |

Web Server

The module features a complete web server with SSI functionality. It is possible to upload web pages to the module, giving access to parameters in the Fieldbus Interface using a customizable interface.

By default the HTTP server is enabled, but it can be enabled/disabled by configuration software on the Ethernet settings page.

Email Client

It is possible to send emails from the module. To send an email, the SMTP server address must be configured. Without a valid SMTP address the module will not be able to send any email messages.

Sending a predefined email on data event

It is possible to send predefined email messages, triggered by an event in the Fieldbus Interface. The Fieldbus Interface is scanned once every 0.5 second. This means that an event must be present longer than 0.5 seconds to ensure that it is detected by the module. It is possible to have up to 10 user defined, and 10 admin defined emails, triggered on different events. These shall be placed in the directories “\user\email\” for user configurable emails and “\email\” for non-user configurable emails. The files must be named ‘email_1.cfg’, ‘email_2.cfg’ ... ‘email_10.cfg’.

The files shall have the following format:

```
[Register]
Area, Offset, Type
[Register match]
Match Value, Mask, Match operand
[To]
Recipient(s)
[From]
Sender
[Subject]
Subject line
[Headers]
Extra Headers
[Message]
Message body
```

| Parameter | Description |
|---------------|---|
| Area | Source Fieldbus Interface Area. Possible values are 'IN' or 'OUT' |
| Offset | Source offset in Fieldbus Area, shall be written in decimal or hexadecimal. |
| Type | Source data type. Possible values are 'byte', 'word', and 'long' |
| Match Value | Value to compare with the source data. Shall be written in decimal or hexadecimal. |
| Mask | The module performs a logical 'and' on the source data and this Mask before the value is compared with the Match Value. The value shall be written in decimal or hexadecimal. |
| Match Operand | Specifies how the data shall be compared with the Match Value. Possible values: '<', '=', '>' |
| Recipient(s) | Destination email addresses, semicolon separated |
| Sender | Sender email address |
| Subject line | Email subject (One line only) |
| Extra Headers | Optional. May be useful for advanced users when for example sending HTML emails etc. |
| Message Body | The actual email message. |

The data is read in the Fieldbus Interface from the area and offset specified by the parameters Area, and Offset. The data size to read is specified by the Type parameter. The module performs a logical 'AND' between the read data and the parameter Mask. The result is compared with the parameter Match Value. How the data shall be compared is specified by the Match Operand.

Example:

```
[Register]
IN, 0x0003, byte
[Register match]
0x20, 0x7F, >
[To]
support@elprotech.com
[From]
ELPRO@elprotech.com
[Subject]
Status
[Message]
All data correct.
```

In the above example:

- A byte is read from the Fieldbus IN area, at byte address 0003h
- The module performs a logical <data> AND 7Fh.
- If the result is larger than 20h, the email message is sent to support@elprotech.com

Note: If the [Register] or [Register match] information is changed, a reset is required for changes to take effect. Other changes will take effect directly without a reset.

Note: Hexadecimal values must be written in the format 0xN where 'N' is the hexadecimal value.

SSI in Email Messages

For predefined emails it is possible to include data in the mails. This is done in a similar way as data is added to web pages with SSI includes. Due to natural reasons, some SSI functions cannot be used in email messages.

The supported SSI commands for emails are:

- DisplayIP
- DisplaySubnet
- DisplayGateway
- DisplayDNS1
- DisplayDNS2
- DisplayHostName
- DisplayDomainName
- DisplayEmailServer
- DisplaySMTPUser
- DisplaySMTPPwd
- DisplayDhcpState
- DisplayDhcpSupport
- printf
- IncludeFile
- SsiOutput

Telnet Server

Through a Telnet client, the user can access the filesystem using a command line interface similar to MS-DOS™. Depending on security settings, different parts of the filesystem can be accessed by the user (see Security above).

The telnet server can be disabled via configuration software on the Ethernet Settings page.

General Commands

help

Syntax: help [general|diagnostic|filesystem]

version

This command will display version information, serial number and MAC ID

exit

This command closes the Telnet session.

Diagnostic Commands

The following commands can be viewed by the command 'help diagnostic'

arps

Display ARP stats and table

iface

Display net interface stats

sockets

Display socket list

routes

Display IP route table

File System Operations

For commands where filenames, directory names or paths shall be given as an argument the names can be written directly or within quotes. For names including spaces the filenames must be surrounded by quotes. It is also possible to use relative pathnames using '.', '\', and '..'

dir

Syntax: dir [path]

Lists the contents of a directory. If no path is given, the contents of the current directory are listed.

md

Syntax: md [[path][directory name]]

Creates a directory. If no path is given, the directory is created in the current directory.

rd

Syntax: rd [[path][directory name]]

Removes a directory. The directory can only be removed if it is empty.

cd

Syntax: cd [path]

Changes current directory.

format

Formats the filesystem. This is a privileged command and can only be called in administration mode.

del

Syntax: del [[path]][filename]]

Deletes a file.

ren

Syntax: ren [[path][old name]] [[path][new name]]

Renames a file or directory.

move

Syntax: move [[source path][source file]] [[destination path]]

This command moves a file or directory from the source location to a specified destination.

copy

Syntax: copy [[source path][source file]] [[destination path][destination file]]

This command creates a copy of the source file at a specified location.

type

Syntax: type [[path]][filename]]

Types (displays) the contents of a file.

mkfile

Syntax: mkfile [[path]][filename]]

Creates an empty file.

append

Syntax: append [[path]][filename]] ["The line to append"]

Appends a line to a file.

df

Displays filesystem info.