

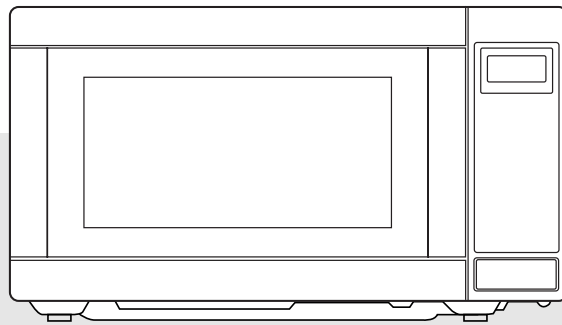

# MICROWAVE OVEN

**KOR-1A5A**

OPERATING  
INSTRUCTIONS



Before operating this oven, please read these instructions completely.

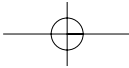

## PRECAUTIONS TO AVOID POSSIBLE EXPOSURE TO EXCESSIVE MICROWAVE ENERGY

- (a) Do not attempt to operate this oven with the door open since open-door operation can result in harmful exposure to microwave energy. It is important not to defeat or tamper with the safety interlocks.
- (b) Do not place any object between the oven front face and the door or allow soil or cleaner residue to accumulate on sealing surfaces.
- (c) **WARNING** : If the door or door seals are damaged, the oven must not be operated until it has been repaired by a competent person : (1) door (bent), (2) hinges and latches(broken or loosened), (3) door seals and sealing surfaces.
- (d) **WARNING** : It is hazardous for anyone other than a competent person to carry out any service or repair operation which involves the removal of a cover which gives protection against exposure to microwave energy.
- (e) **WARNING** : Liquids or other foods must not be heated in sealed containers since they are liable to explode.
- (f) **WARNING** : Only allow children or infirm persons to operate this oven with adequate Adult Supervision.
- (g) **WARNING** : It is not recommended for use in a environment where excessive vibration could be experienced.

## TABLE OF CONTENTS

PRECAUTIONS TO AVOID POSSIBLE EXPOSURE TO EXCESSIVE MICROWAVE ENERGY .....	1
IMPORTANT SAFETY INSTRUCTIONS .....	2
EARTHING INSTRUCTIONS .....	3
INSTALLATION .....	3
FEATURES DIAGRAM .....	4~5
OPERATION PROCEDURE .....	6
HOW TO SET THE OVEN CONTROLS .....	7~13
CARE OF YOUR MICROWAVE OVEN .....	14
BEFORE YOU CALL FOR SERVICE .....	15
CARE AND CLEANING.....	15
QUESTIONS AND ANSWERS .....	16
SPECIFICATIONS .....	17
COOKING INSTRUCTIONS .....	18
USE YOUR MICROWAVE OVEN SAFELY .....	19
ARCING .....	19
MICROWAVING PRINCIPLES .....	20
HOW MICROWAVES COOK FOOD .....	20
CONVERSION CHARTS .....	20
COOKING TECHNIQUES .....	21
GENERAL DEFROSTING GUIDE .....	22
DEFROSTING CHART .....	23
COOKING & REHEATING CHART .....	24
VEGETABLE CHART .....	25
RECIPES .....	27~29

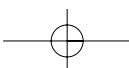



# IMPORTANT SAFETY INSTRUCTIONS

## READ CAREFULLY AND KEEP FOR FUTURE REFERENCE

**WARNING :** To prevent fire, burns, electric shock and other warnings:

Listed below are, as with all appliances, certain rules to follow and safeguards to assure high performance from this oven:

1. Do not use the oven for any reason other than food preparation, such as for drying clothes, paper, or any other nonfood items or for sterilizing purposes.
2. Do not use the oven when empty, this could damage the oven.
3. Do not use the oven cavity for any type of storage, such as papers, cookbook, cookware, etc.
4. Do not operate the oven without the glass tray in place. Be sure it is properly sitting on the rotating base.
5. Make sure you remove caps or lids prior to cooking when you cook food sealed in bottles.
6. Do not put foreign material between the oven surface and door. It could result in excessive leakage of microwave energy.
7. Do not use recycled paper products for cooking. They may contain impurities which could cause sparks and/or fires when used during cooking.
8. Do not pop popcorn unless popped in a microwave approved popcorn popper or unless it's commercially packaged and recommended especially for microwave ovens. Microwave popped corn produces a lower yield than conventional popping; there will be a number of unpopped kernels. Do not use oil unless specified by the manufacturer.
9. Do not cook any food surrounded by a membrane, such as egg yolks, potatoes, chicken livers, etc., without first piercing them several times with a fork.
10. Do not pop popcorn longer than the manufacturer's directions. (popping time is generally below 3 minutes). Longer cooking does not yield more popped corn, it can cause scorchings and fire. Also, the cooking tray can become too hot to handle or may break.
11. If smoke is observed, switch off or unplug the appliance and keep the door closed in order to stifle any flames.
12. When heating food in plastic or paper containers, keep an eye on the oven due to the possibility of ignition.
13. The contents of feeding bottles and baby food jars shall be stirred or shaken and the temperature checked before consumption, in order to avoid burns.
14. Always test the temperature of food or drink which has been heated in a microwave oven before you give it to somebody, especially to children or elderly people. This is important because things which have been heated in a microwave oven carry on getting hotter even though the microwave oven cooking has stopped.
15. Eggs in their shell and whole hard-boiled eggs should not be heated in microwave ovens since they may explode, even after microwave heating has ended;
16. Keep the waveguide cover clean at all times. Wipe the oven interior with a soft damp cloth after each use. If you leave grease or fat anywhere in the cavity it may overheat, smoke or even catch fire when next using the oven.
17. Never heat oil or fat for deep frying as you cannot control the temperature and doing so may lead to overheating and fire.
18. Microwave heating of beverages can result in delayed eruptive boiling, therefore care must be taken when handling the container.

## SAVE THESE INSTRUCTIONS

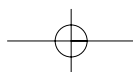



# EARTHING INSTRUCTIONS

This appliance must be earthed. In the event of an electrical short circuit, earthing reduces the risk of electric shock by providing an escape wire for the electric current. This appliance is equipped with a cord having a earthing wire with a earthing plug. The plug must be plugged into an outlet that is properly installed and earthed.

**WARNING :** Improper use of the earthing plug can result in a risk of electric shock. Consult a qualified electrician or serviceman if the earthing instructions are not completely understood, or if doubt exists as to whether the appliance is properly earthed. If it is necessary to use an extension cord, use only a 3-wire extension cord that has a 3-blade earthing plug, and a 3-slot receptacle that will accept the plug on the appliance. The marked rating of the extension cord should be equal to or greater than the electrical rating of the appliance.

## INSTALLATION

### 1. Ventilation

Do not block air vents. If they are blocked during operation, the oven may overheat and eventually cause a failure. For proper ventilation, allow above 50mm of space between oven sides, rear and the minimum height of free space necessary above the top surface of the oven is 100mm.

### 2. Steady, flat location

This oven should be set on a steady, flat surface. This oven is designed for counter top use only.

### 3. Leave space behind and side

All air vents should be kept clear. If all vents are covered during operation, the oven may overheat and, eventually, fail.

### 4. Away from radio and TV sets

Poor television reception and radio interference may result if the oven is located close to a TV, Radio antenna, feeder and so on. Position the oven as far from them as possible.

### 5. Away from heating appliance and water taps

Keep the oven away from hot air, steam or Splashing water when choosing a place to position it, or the insulation might be adversely affected and breakdowns occur.

### 6. Power supply

- Check your local power source. This oven requires a current of approximately 10 amperes, 230~240V 50Hz.
- Power supply cord is about 1.8 meters long.
- The voltage used must be the same as specified on this oven. Using a higher voltage may result in a fire or other accident causing oven damage. Using low voltage will cause slow cooking. We are not responsible for damage resulting from use of this oven with a voltage or ampere fuse other than those specified.
- If the supply cord is damaged, it must be replaced by the manufacturer or its service agent or a similarly qualified person in order to avoid a hazard.

### 7. Examine the oven after unpacking for any damage such as:

A misaligned door, broken door, a dent in cavity. If any of the above are visible, DO NOT INSTALL, and notify dealer immediately.

### 8. Do not operate the oven if it is colder than room temperature.

(This may occur during delivery in cold weather.) Allow the oven to become room temperature before operating.

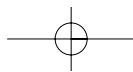

# FEATURES DIAGRAM

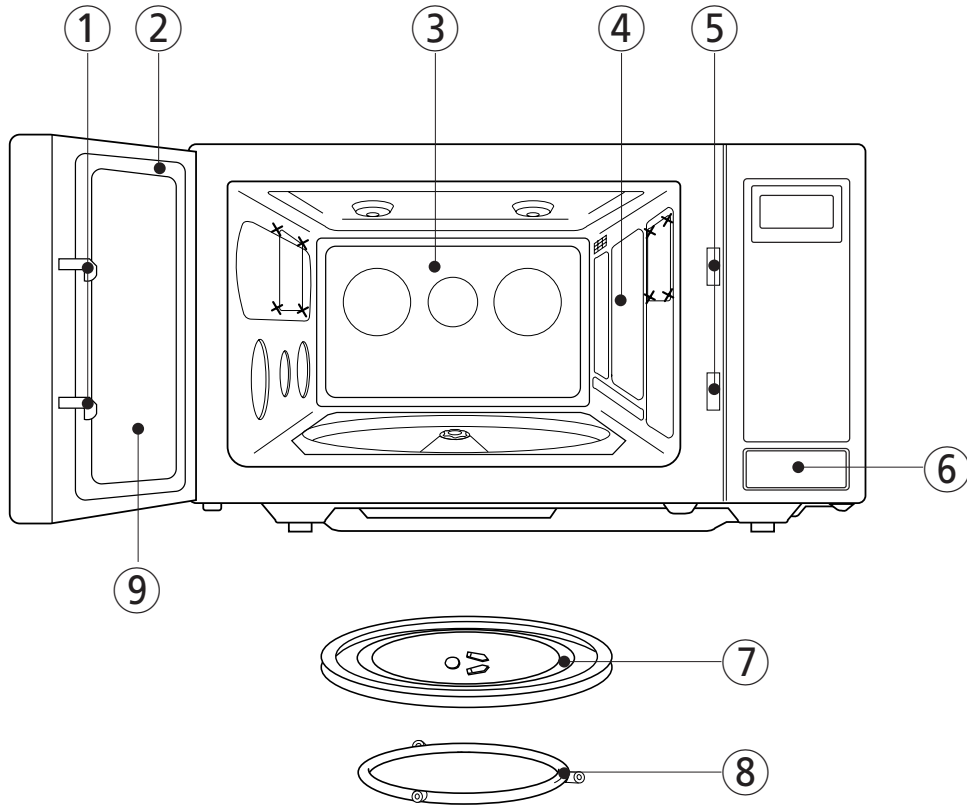

- ① **Door latch** - If the door is opened while the oven is operating, the magnetron will automatically shut off.
- ② **Door seal** - The door seal maintains the microwave within the oven cavity and prevents microwave leakage.
- ③ **Oven cavity**
- ④ **Spatter shield** - Protects the microwave outlet from splashes of cooking foods.
- ⑤ **Safety interlock system** - Prevents the oven from operating while the door is opened.

- ⑥ **Door release button** - Pushing this button stops oven operation and opens the door.
- ⑦ **Glass cooking tray** - Made of special heat resistant glass. The tray must always be in proper position before operating.
- ⑧ **Roller guide** - Supports the glass cooking tray.
- ⑨ **Door screen** - Allows viewing of food. The screen is designed so that light can pass through, but not the microwaves.

## FEATURES DIAGRAM (continued)

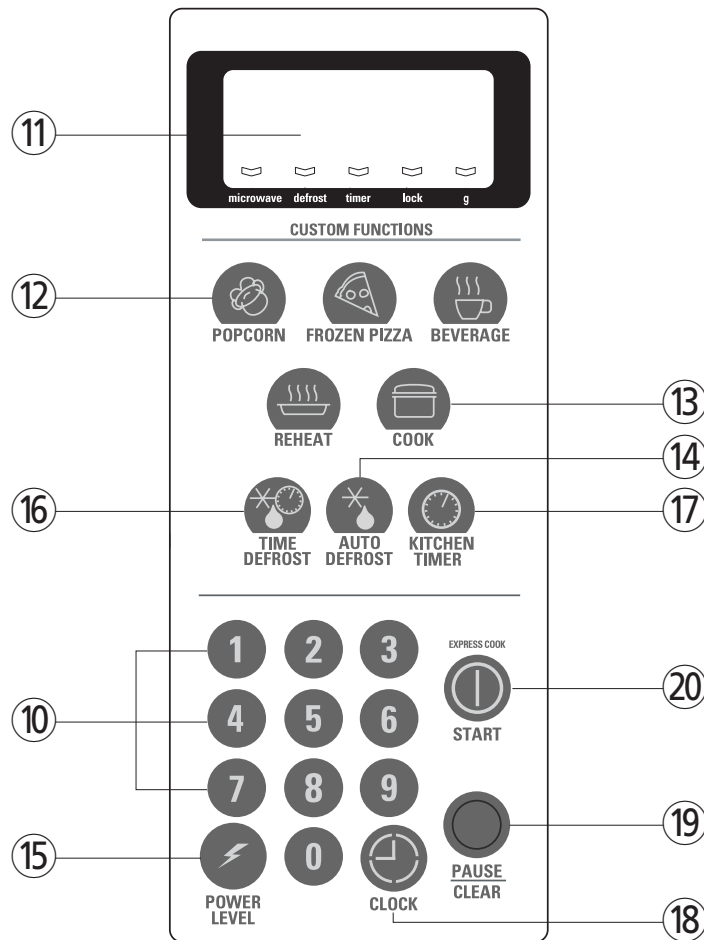

- ⑩ **Time set pad** - Used to set the cooking time and the clock.
- ⑪ **Display** - Cooking time, power level, indicators and clock are displayed.
- ⑫ **One touch** - Used to cook or reheat specific quantities of food.
- ⑬ **Cook** - Used to cook or reheat.
- ⑭ **Auto defrost** - Used to defrost foods.(for weight)
- ⑮ **Power Level** - Used to set power level.
- ⑯ **Time Defrost** - Used to defrost foods.(for time)
- ⑰ **Kitchen Timer** - Used as a minute timer, delay cooking, hold setting after cooking.
- ⑱ **Clock** - Used to set clock.
- ⑲ **Pause/Clear** - Used to stop the oven operation or to delete the cooking data.
- ⑳ **Start / Express cook**- Used to start the oven and also used to set a reheat time.

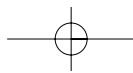

# OPERATION PROCEDURE

This section includes useful information about oven operation.

1. Plug power supply cord into 230~240V 50Hz power outlet.
2. After placing the food in a suitable container, open the oven door and put it on the glass tray.  
The glass tray and roller guide must always be in place during cooking.
3. Shut the door. Make sure that it is firmly closed.

**1** The oven light is on when the microwave oven is operating or the door is opened.

**2** The oven door can be opened at any time during operation by touching the door release button on the control panel. The oven will automatically shut off.

**3** Each time a pad is touched, a BEEP will sound to acknowledge the touch.

**4** The oven automatically cooks on full power unless set to a lower power level.

**5** The display will show ":0" when the oven is plugged in.

**6** Time clock returns to the present time when the cooking time ends.

**7** When the PAUSE/CLEAR pad is touched during the operation, the oven stops cooking and all information is retained.

To erase all information (except the present time), touch the PAUSE/CLEAR pad once more. If the oven door is opened during the oven operation, all information is retained.

**8** If the START pad is touched and the oven does not operate, check the area between the door and door seal for obstructions and make sure the door is closed securely. The oven will not start cooking until the door is completely closed or the program has been reset.

Make sure the oven is properly installed and plugged into the electrical outlet.

## WATTAGE OUTPUT CHART

- The power-level is set by pressing the POWER LEVEL pad. The chart shows the display, the power level and the percentage of power.

Touch POWER LEVEL pad	Power Level (Display)	Approximate Percentage of Power
once	P-HI	100%
twice	P-90	90%
3 times	P-80	80%
4 times	P-70	70%
5 times	P-60	60%
6 times	P-50	50%
7 times	P-40	40%
8 times	P-30	30%
9 times	P-20	20%
10 times	P-10	10%
11 times	P-00	0%

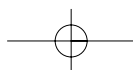

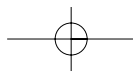

# CONTROLS

## SETTING THE CLOCK

When the oven is first plugged in, the display will flash ":0" and a tone will sound. If the AC power ever goes off, the display shows ":0" when the power comes back on.



1. Touch CLOCK pad.  
This is a 12 hour clock system.
2. Touch CLOCK pad once more.  
This is a 24hour clock system.

**NOTE:** This oven has a multiple clock system, omit this step.

3. Enter the correct time of day by touching the numbers in sequence.

4. Touch CLOCK pad.



The display stops blinking, and the colon starts blinking. If you selected 12 hour clock system, this digital clock allows you to set from 1:00 to 12:59. If you selected 24 hour clock system, this digital clock allows you to set from 0:00 to 23:59.

5. Touch PAUSE/CLEAR pad.

**NOTE:** If you attempt to enter an incorrect time, the time will not be set and a error signal tone will sound. Touch the CLOCK pad and re-enter the time.

## TIME DEFROSTING

When TIME DEFROST is selected, the automatic cycle divides the defrosting time into periods of alternating defrost and stand times by cycling on and off.

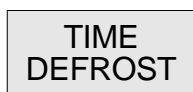

1. Touch TIME DEFROST pad.

The DEFROST indicator lights and " : 0" is displayed.

2. Touch number pads for the desired defrosting time.

The display will show the numbers you pressed in the order you touched.

3. Touch START pad.

**NOTE:** Your oven can be programmed for 99 minutes 99 seconds.(99:99)

When you touch START pad, the DEFROST indicator starts blinking to show the oven is in the DEFROST mode. The display counts down the time to show you how much defrosting time is left in the DEFROST mode. The oven beeps during the defrosting cycle to signal that the food needs to be turned or rearranged. When the defrosting time ends, you will hear 3 beeps.

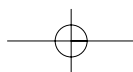



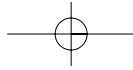

## AUTO DEFROSTING

AUTO DEFROSTING lets you easily defrost food by eliminating guesswork in determining defrosting time. Follow the steps below for easy defrosting.

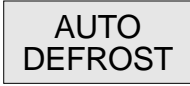

1. Touch AUTO DEFROST pad.

When you touch AUTO DEFROST pad once, The g indicator light and "500" is displayed. By repeatedly touching this pad, you can select other weight as shown in the chart below.

### \* WEIGHT DEFROST CHART

Touch pad	MEAT
once	500 g
twice	800 g
3 times	1000 g
4 times	1200 g



1. Touch START pad.

When you touch START pad, the display changes into cooking time and the oven starts cooking.

The defrosting time is automatically determined by the weight selected. The g indicator goes off and the DEFROST indicator blinks and the defrosting time counts down in the display window. The oven beeps during the defrosting cycle to signal that the food needs to be turned or rearranged. When the defrosting time ends, you will hear 3 beeps.

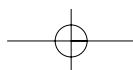

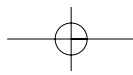

## COOKING IN ONE STAGE



1. Touch POWER pad.  
(Select desired power level.)

The M/W indicator lights.  
The display will show what you touched.

2. Touch the number pads for the cooking time.

**NOTE:** If step is omitted the oven will cook at full power.

3. Touch START pad.

This example shows power level 5.  
The display will show the numbers you pressed in the order you touched.

**NOTE:** Your oven can be programmed for 99 minutes 99 seconds.(99:99)

When you touch START pad, the M/W indicator starts blinking to show the oven is cooking. The display counts down the time to show how much cooking time is left. When the cooking time ends, you will hear 3 beeps.

**NOTE:** Using lower power levels increases the cooking time which is recommended for foods such as cheese, milk and slow cooking of meats.

## COOKING IN TWO STAGES

All recipes require frozen foods to be defrosted fully before cooking. This oven can be programmed to automatically defrost foods before cooking.



1. Touch DEFROST pad.

The DEFROST indicator lights and “ : 0” is displayed.

2. Touch number pads for the defrosting time you want.

The display will show the numbers you pressed in the order you touched.



3. Touch POWER LEVEL pad.  
(Select desired power level.)

The M/W indicator lights and 'P-HI will be displayed. This example shows power level 5

4. Touch number pads for desired cooking time.

5. Touch START pad.

The display will show the number you pressed in the order you touched.

When you touch START pad, the DEFROST and M/W indicators come on to confirm the power levels selected. The DEFROST indicator starts blinking to show you that the oven is in DEFROST mode. The display counts down the time remaining in DEFROST mode. When the oven beeps, turn over, break apart and/or redistribute the food. At the end of DEFROST mode, the oven will beep and start M/W cook. The DEFROST indicator goes off and the M/W indicator starts blinking. The display counts down the time remaining in M/W cook. When M/W cook ends, you will hear 3 beeps.

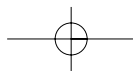



## KITCHEN TIMER MODE

Timer operates as a minute timer, and can also be set to delay cooking, or used as a hold setting after cooking. However, delay cooking can not be programmed for defrost. Timer operates without microwave energy.

### HOW TO USE AS A MINUTE TIMER

- |   |  |
|---|--|
| <div style="border: 1px solid gray; padding: 5px; width: fit-content; margin-bottom: 10px;">KITCHEN<br/>TIMER</div> <ol style="list-style-type: none"> <li>1. Touch KITCHEN TIMER pad.</li> <li>2. Press the amount of time you want to count down.</li> <li>3. Touch START pad.</li> </ol> | <p>The KITCHEN TIMER indicator lights and “ : 0 ” is displayed.</p> <p>The display will show the numbers you pressed in the order you touched.</p> <p>The display counts down the time remaining in KITCHEN TIMER mode. When KITCHEN TIMER mode ends, you will hear 3 beeps.</p> |
|---|--|

### HOW TO USE TO DELAY THE START OF COOKING

- |   |   |
|---|---|
| <div style="border: 1px solid gray; padding: 5px; width: fit-content; margin-bottom: 10px;">KITCHEN<br/>TIMER</div> <ol style="list-style-type: none"> <li>1. Touch KITCHEN TIMER pad.</li> <li>2. Press the amount of time you want to delay time.</li> <li>3. Program the desired power level and cooking time for food to be cooked.</li> <li>4. Touch START pad.</li> </ol> | <p>The KITCHEN TIMER indicator lights and “ : 0 ” is displayed.</p> <p>The display will show the numbers you pressed in the order you touched.</p> <p>The kitchen timer will begin counting down to zero and cooking will then begin.</p> |
|---|---|

### HOW TO USE TO SET A HOLDING TIME

- |  |  |
|--|--|
| <ol style="list-style-type: none"> <li>1. Program the desired defrosting time.</li> </ol> <div style="border: 1px solid gray; padding: 5px; width: fit-content; margin-bottom: 10px;">KITCHEN<br/>TIMER</div> <ol style="list-style-type: none"> <li>2. Touch KITCHEN TIMER pad.</li> <li>3. Press the amount of time you want the oven to hold.</li> <li>4. Touch START pad.</li> </ol> | <p>The KITCHEN TIMER indicator lights and “ : 0 ” is displayed.</p> <p>The display will show the numbers you pressed in the order you touched.</p> <p>Defrosting will start. After defrosting, stand time will count down.</p> |
|--|--|

**NOTE:** Your oven can be programmed for 99 minutes 99 seconds. (99:99)

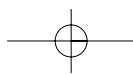



## EXPRESS COOK

EXPRESS COOK allows you to reheat for 30 seconds at 100% (full power) by simply touching the EXPRESS COOK pad.

By repeatedly touching the EXPRESS COOK pad, you can also extend reheating time to 5 minutes by 30 second increments.

### EXPRESS COOK

1. Touch EXPRESS COOK pad.

When you touch EXPRESS COOK, ":30" is displayed.

After 1.5 seconds, the oven starts reheating.

## ONE TOUCH COOKING

One touch cook allows you to cook or reheat many of your favorite foods by touching just one pad. To increase quantity, touch chosen pad until number in display is same as desired quantity to cook. (except for POPCORN)

### POPCORN

1. Remove plastic wrap. Follow manufacture's directions for placement and care in opening.

When you touch POPCORN pad once, "99" is displayed.

After the 1.5 seconds, the display shows the cooking time and the oven starts cooking.

2. Touch POPCORN pad once for 99g bag.

- NOTE:**
1. Use prepackaged room-temperature microwave popcorn.
  2. Place bag in oven according to manufacturer's directions.
  3. Pop only one bag at a time.
  4. After popping, open bag carefully: popcorn and steam are extremely hot.
  5. Do not reheat unpopped kernels or reuse bag.
  6. Do not leave oven unattended while popping popcorn.

**CAUTION :** If prepackaged popcorn is of a different weight than the recommended weight, do not use the POPCORN pad. Follow the popcorn manufacturers instructions.

### FROZEN PIZZA

1. Follow package directions for preparation.
2. Touch FROZEN PIZZA pad once for 200g pizza or twice for 400g pizza.

When you touch FROZEN PIZZA pad once, "200" is displayed.

After 1.5 seconds, the display shows the cooking time and the oven starts cooking.

**\* FROZEN PIZZA \***

- 200 g : Touch FROZEN PIZZA once.
- 400 g : Touch FROZEN PIZZA twice within 1.5 seconds.

- NOTE:**
1. Use only one frozen pizza at a time.
  2. Use only frozen pizza made for microwave ovens.
  3. If the cheese of frozen pizza does not melt sufficiently, cook a few seconds longer.
  4. Some brands of frozen pizza may require more or less cooking time.

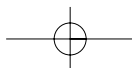



## ONE TOUCH COOKING (CONTINUED)

<b>BEVERAGE</b>	<ol style="list-style-type: none"> <li>1. Pour beverage in microwave mug. Place it on the turntable. Do not cover. Stir before serving.</li> <li>2. Touch BEVERAGE pad once for 1 cup, twice for 2 cups or three times for 3 cups.</li> </ol>	<p>When you touch BEVERAGE pad once, "1" is displayed. After 1.5 seconds, the display changes to cooking time and the oven starts cooking.</p>
-----------------	---	--

<p><b>* BEVERAGE * (200ml/cup)</b></p> <ul style="list-style-type: none"> <li>• 1 cup(mug) : Touch BEVERAGE once.</li> <li>• 2 cups(mugs) : Touch BEVERAGE twice within 1.5 seconds.</li> <li>• 3 cups(mugs) : Touch BEVERAGE three times within 1.5 seconds.</li> </ul>
--

<b>REHEAT</b>	<ol style="list-style-type: none"> <li>1. Touch REHEAT pad once for 350g or twice for 450g.</li> </ol>	<p>When you touch REHEAT pad once, "350" is displayed. After 1.5 seconds, the display is changed into cooking time and the oven starts cooking.</p>
---------------	--	---

<p><b>* REHEAT *</b></p> <ul style="list-style-type: none"> <li>• 350 g : Touch REHEAT once.</li> <li>• 450 g : Touch REHEAT twice within 1.5 seconds.</li> </ul>
---

## COOK

Cook allows you to cook or reheat many of your favorite foods by repeatedly touching cook pad.

<b>COOK</b>	<ol style="list-style-type: none"> <li>1. Touch COOK pad.</li> </ol>	<p>When you touch COOK pad once, " AC-1" is displayed. By repeatedly touching this pad, you can select other food category as shown in the chart below.</p>
-------------	--	---

CATEGORY	FOOD	WEIGHT	TOUCH PAD	DIRECTIONS
AC-1	BREAD	4slices	Touch COOK once	Place bread on a microwave dish.
AC-2	SOUP	350 g	Touch COOK twice	Pour soup into microwave bowl or mug. Stir before serving.
AC-3	BAKED POTATO	3potatoes (200-250 g each)	Touch COOK three times	Wash and pierce potatoes with a fork. Place them on turntable.
AC-4	FRESH VEGETABLE	200 g	Touch COOK four times	Trim and wash the mixed vegetables. Place them in the round dish. Add 2 Tbsp water.
AC-5	FROZEN VEGETABLE	200 g package	Touch COOK five times	Place the vegetables in the round dish. Add 2 Tbsp water.

<b>START</b>	<ol style="list-style-type: none"> <li>2. Touch START pad.</li> </ol>	<p>When you touch START pad, the display changes to cooking time and the oven starts cooking.</p>
--------------	---	---





## CHILD SAFETY LOCK

---

The safety lock prevents unwanted oven operation such as by small children.

To set, press and hold PAUSE/CLEAR for 3 seconds, LOCK indicator lights.

To cancel, press and hold PAUSE/CLEAR for 3 seconds, LOCK indicator goes off.

---

## TO STOP THE OVEN WHILE THE OVEN IS OPERATING

---

1. Press PAUSE/CLEAR pad.
  - You can restart the oven by touching START pad.
  - Touch PAUSE/CLEAR once more to erase all instructions.
  - You must enter in new instructions.
2. Open the door.
  - You can restart the oven by closing the door and touching START.

**NOTE:** Oven stops operating when door is opened.



# CARE OF YOUR MICROWAVE OVEN

**1** Turn the oven off before cleaning.

**2** Keep the inside of the oven clean. When food spatters or spilled liquids adhere to oven walls, wipe with a damp cloth. Mild detergent may be used if the oven gets very dirty. The use of harsh detergent or abrasives is not recommended.

**3** The outside oven surface should be cleaned with soap and water, rinsed and dried with a soft cloth. To prevent damage to the operating parts inside the oven, water should not be allowed to seep into the ventilation openings.

**4** If the Control Panel becomes wet, clean with a soft, dry cloth. Do not use harsh detergents or abrasives on Control Panel.

**5** If steam accumulates inside or around the outside of the oven door, wipe with a soft cloth. This may occur when the microwave oven is operated under high humidity conditions and in no way indicates malfunction of the unit.

**6** It is occasionally necessary to remove the glass tray for cleaning. Wash the tray in warm sudsy water or in a dishwasher.

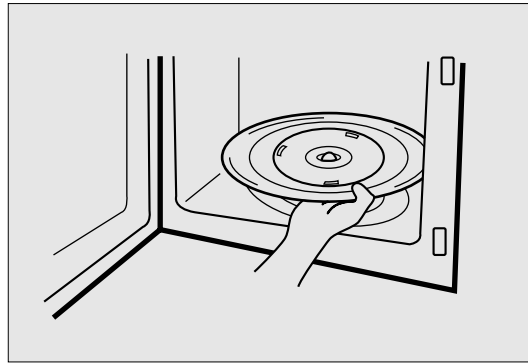

**7** The roller guide and oven cavity floor should be cleaned regularly to avoid excessive noise.

Simply wipe the bottom surface of the oven with mild detergent water or window cleaner and dry. The roller guide may be washed in mild sudsy water.

## ROLLER GUIDE

- 1** The ROLLER GUIDE and oven floor should be cleaned frequently to prevent excessive noise.
- 2** The ROLLER GUIDE MUST ALWAYS be used for cooking together with the Glass Tray.

## GLASS TRAY

- 1** DO NOT operate the oven without the Glass Tray in place.
- 2** DO NOT use any other Glass Tray with this oven.
- 3** If Glass Tray is hot, ALLOW TO COOL before cleaning or placing it in water.
- 4** DO NOT cook directly on the Glass Tray.

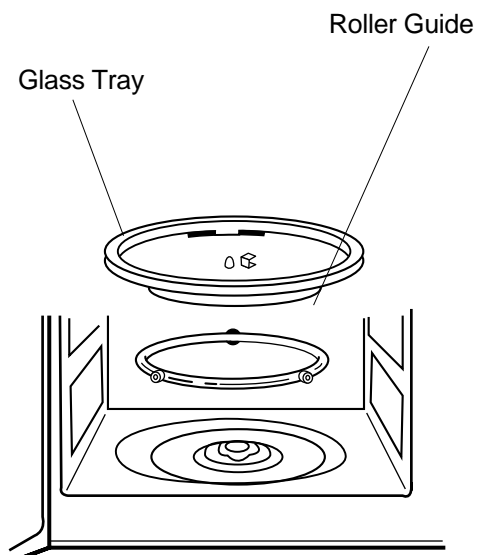

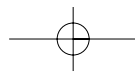

## BEFORE YOU CALL FOR SERVICE

Refer to following checklist, you may prevent an unnecessary service call.

\* The oven doesn't work :

1. Check that the power cord is securely plugged in.
2. Check that the door is firmly closed.
3. Check that the cooking time is set.
4. Check for a blown circuit fuse or tripped main circuit breaker in your house.

\* Sparking in the cavity;

1. Check utensils. Metal containers or dishes with metal trim should not be used.
2. Check that metal skewers or foil does not touch the interior walls.

If there is still a problem, contact your nearest NEC Service Centre.  
A list of these centres is included in this instruction manual.

**DO NOT ATTEMPT TO SERVICE THE OVEN YOURSELF !**

## CARE AND CLEANING

Although your oven is provided with safety features, it is important to observe the following:

1. It is important not to defeat or tamper with safety interlocks.
2. Do not place any object between the oven front face and the door or allow residue to accumulate on sealing surfaces. Wipe the sealing area frequently with a mild detergent, rinse and dry. Never use abrasive powders or pads.
3. When opened, the door must not be subjected to strain, for example, a child hanging on an opened door or any load could cause the oven to fall forward to cause injury and also damage to the door. Do not operate the oven if it is damaged, until it has been repaired by a competent service technician. It is particularly important that the oven closes properly and that there is no damage to the:
  - i) Door(bent)
  - ii) Hinges and Hooks(broken or loosened)
  - iii) Door seals and sealing surfaces.
4. The oven should not be adjusted or repaired by anyone except a properly competent service technician.
5. The oven should be cleaned regularly and any food deposits removed;
6. Failure to maintain the oven in a clean condition could lead to deterioration of the surface that could adversely affect the life of the appliance and possibly result in a hazardous situation;

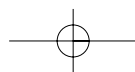



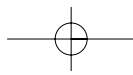

## QUESTIONS AND ANSWERS

- \* **Q: I accidentally ran my microwave oven without any food in it. Is it damaged?**  
**A:** Running the oven empty for a short time will not damage the oven. However, it is not recommended.
- \* **Q: Can the oven be used with the glass tray or roller guide removed?**  
**A:** No. Both the glass tray and roller guide must always be used in the oven before cooking.
- \* **Q: Can I open the door when the oven is operating?**  
**A:** The door can be opened anytime during the cooking operation. Then microwave energy will be instantly switched off and the time setting will maintain until the door is closed.
- \* **Q: Why do I have moisture in my microwave oven after cooking?**  
**A:** The moisture on the side of your microwave oven is normal. It is caused by steam from cooking food hitting the cool oven surface.
- \* **Q: Does microwave energy pass through the viewing screen in the door?**  
**A:** No. The metal screen bounces back the energy to the oven cavity. The holes are made to allow light to pass through. They do not let microwave energy pass through.
- \* **Q: Why do eggs sometimes pop?**  
**A:** When baking or poaching eggs, the yolk may pop due to steam build-up inside the yolk membrane. To prevent this, simply pierce the yolk with a toothpick before cooking. Never cook eggs without piercing their shells.

## QUESTIONS AND ANSWERS (continued)

- \* **Q: Why is standing time recommended after cooking operation has been completed?**  
**A:** Standing time is very important.  
 With microwave cooking, the heat is in the food, not in the oven. Many foods build up enough internal heat to allow the cooking process to continue, even after the food is removed from the oven. Standing time for joints of meat, large vegetables and cakes is to allow the inside to cook completely, without overcooking the outside.
- \* **Q: What does “standing time” mean?**  
**A:** “Standing time” means that food should be removed from the oven and covered for additional time to allow it to finish cooking. This frees the oven for other cooking.
- \* **Q: Why does my oven not always cook as fast as the microwave cooking guide says?**  
**A:** Check your cooking guide again, to make sure you’ve followed directions exactly ; and to see what might cause variations in cooking time. Cooking guide times and heat settings are suggestions, to help prevent over-cooking... the most common problem in getting used to a microwave oven. Variations in the size, shape and weights and dimensions could require longer cooking time. Use your own judgement along with the cooking guide suggestions to check whether the food has been properly cooked just as you would do with a conventional cooker.
- \* **Q: Will the microwave oven be damaged if it operates while empty?**  
**A:** Yes. Never run it empty.
- \* **Q: Can I operate my microwave oven without the turntable or turn the turntable over to hold a large dish?**  
**A:** No. If you remove or turn the turntable over, you will get poor cooking results. Dishes used in your oven must fit on the turntable.
- \* **Q: Is it normal for the turntable to turn in either direction?**  
**A:** Yes. The turntable rotates clockwise or counterclockwise, depending on the rotation of the motor when the cooking cycle begins.
- \* **Q: Can I pop popcorn in my microwave oven? How do I get the best results?**  
**A:** Yes. Pop packaged microwave popcorn following manufacture’s guidelines. Do not use regular paper bags. Use the “listening test” by stopping the oven as soon as the popping slows to a “pop” every 1 or 2 seconds. Do not repop unpopped kernels. Do not pop popcorn in glass cookware.

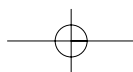



# SPECIFICATIONS

POWER SUPPLY		230~240V 50Hz SINGLE PHASE WITH GROUNDING
MICROWAVE	POWER CONSUMPTION	1400 W
	OUTPUT POWER	1000 W
	FREQUENCY	2450 MHz
OUTSIDE DIMENSIONS (W X H X D)		539 x 300 x 406 mm
CAVITY DIMENSIONS (W X H X D)		354 x 228 x 373 mm
NET WEIGHT		APPROX. 15.5KG
TIMER		99 min. 99 sec.
POWER LEVELS		10 LEVELS

\* Specifications are subject to change without notice.



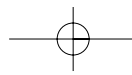

# COOKING INSTRUCTIONS

Only use utensils that are suitable for use in microwave ovens.

## UTENSILS TEST

Place the utensil in question next to a glass measure filled with water, in the microwave oven. Microwave at high power for 1-2 minutes. If the water heats up, but the utensil remains cool, the utensil is microwave-safe. However if the utensil becomes warm, microwaves are being absorbed by the utensil and it should not be in the microwave oven. You probably have many items on hand in your kitchen right now that can be used as cooking equipment in your microwave oven. Read through the following checklist.

# COOKING UTENSILS

## *Recommended Use*

- **Glass and glass-ceramic bowls and Dishes** - Use for heating or cooking.
- **Microwave browning dish** - Use to brown the exterior of small items such as steaks, chops, or pancakes. Follow the directions provided with the browning dish.
- **Microwaveable plastic wrap** - Use to retain steam. Leave a small opening for some steam to escape and avoid placing it directly on the food.
- **Wax paper** - Use as a cover to prevent spattering.
- **Paper towels, and napkins and cups** - Use for short term heating and covering; they absorb excess moisture when warming food. Pay special attention as over-heating may cause a fire in your oven. Do not use re-cycled paper products, e.g. kitchen roll unless they say they are specifically designed for use in a microwave oven. These products contain impurities which may cause sparks and/or fires when used.
- **Thermometers** - Use only those labeled "Microwave Safe" and follow all directions. Check the food in several places. Conventional thermometers may be used once the food has been removed from the oven.
- **Microwave cling film, microwave roasting bags** - Microwave cling film and bags must be vented for steam to escape, pierce in 4~5 places. Do not use plastic or metal ties as they may melt or catch fire due to electrical 'arcing'.

## *Limited Use*

- **Aluminium foil** - Use narrow strips of foil to prevent overcooking of exposed areas. Using too much foil can damage your oven, so be careful.
- **Labelled and metallic** - Use these if they are labeled "Microwave Safe." If they are not labeled, test them to make sure they can be used safely. Never use dishes with metallic trim.
- **Labelled** - Use only if labeled "Microwave Safe." Other plastics can melt.
- **Thin plastic, paper, straw and wooden containers** - Always attend the oven closely. Look at the oven from time to time when cooking or reheating food in disposable containers of plastic, paper or other combustible material. Only use for warming food. Pay special attention as over-heating may cause a fire in your oven.

## *Not Recommended*

- **Glass jars and bottles** - Regular glass is too thin to be used in a microwave, and can shatter.
- **Paper bags** - These are a fire hazard, except for popcorn bags that are designed for microwave use.
- **Styrofoam plates and cups** - These can melt and leave an unhealthy residue on food.
- **Plastic storage and food containers** - Containers such as margarine tubs can melt in the microwave.
- **Metal utensils** - These can damage your oven. Remove all metal before cooking.

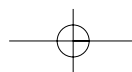

# USE YOUR MICROWAVE OVEN SAFELY

## General Use

Do not attempt to defeat or tamper with safety interlocks.

Do not place any object between the oven front frame and the door or allow residue to build up on sealing surfaces. Wipe with a mild detergent, rinse and dry. Never use abrasive powders or pads.

Do not subject the oven door to strain or weight such as a child hanging on an open door.

This could cause the oven to fall forward resulting in injury to you and damage to the oven.

Do not operate the oven if door seals or sealing surfaces are damaged; or if door is bent; or if hinges are loose or broken.

Do not operate the oven empty. This will damage the oven.

Do not attempt to dry clothes, newspapers or other materials in the oven. They may catch on fire.

Do not use recycled paper products as they may contain impurities which may cause sparks or fires.

Do not hit or strike the control panel with hard objects. This can damage the oven.

## Food

Never use your microwave oven for home canning. The oven is not designed for proper home canning. Improperly canned food may spoil and be dangerous to consume.

Always use the minimum recipe cooking time. It is better to undercook rather than overcook foods.

Undercooked foods can be returned to the oven for more cooking. If food is overcooked, nothing can be done.

Heat small quantities of food or foods with low moisture carefully. These can quickly dry out, burn or catch on fire.

Do not heat eggs in the shell. Pressure may build up and eggs can explode.

Potatoes, apples, egg yolks and sausages are examples of food with non-porous skins.

These must be pierced before cooking to prevent bursting.

Do not attempt to deep fat fry in your microwave oven.

Always stir liquids before heating. Heated liquids can erupt, if not mixed with air.

Do not leave the oven unattended while popping corn.

Do not pop corn in paper bag unless it is a commercially prepared Microwave Popcorn product.

The kernels can overheat and ignite a brown paper bag.

Do not put packaged Microwave Popcorn bags directly on the oven tray. Place the package on a microwave safe glass or ceramic plate to avoid overheating and cracking the oven tray.

Do not exceed the Microwave Popcorn manufacturers suggested popping time.

Longer popping does not yield more popcorn but it can result in scorch, burn or fire. Remember, the Popcorn bag and tray can be too hot to handle. Remove with caution and use pot holders.

## ARCING

*If you see arcing, press **PAUSE/CLEAR** pad and correct the problem.*

Arcing is the microwave term for sparks in the oven.

Arcing is caused by:

- Metal or foil touching the side of the oven.
- Foil not molded to food (upturned edges act like antennas).
- Metal, such as twist-ties, poultry pins, or gold rimmed dishes, in the microwave.
- Recycled paper towels containing small metal pieces being used in the microwave.

# MICROWAVING PRINCIPLES

Microwave energy has been used in this country to cook and reheat food since early experiments with RADAR in World War II. Microwaves are present in the atmosphere all the time, both naturally and manmade sources. Manmade sources include radar, radio, television, telecommunication links and car phones.

## HOW MICROWAVES COOK FOOD

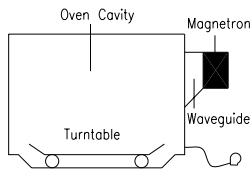

In a microwave oven, electricity is converted into microwave by the **MAGNETRON**.

### ► TRANSMISSION

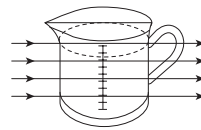

Then they pass through the cooking containers to be absorbed by the water molecules in the food, all foods contain water to a more or lesser extent.

### ► REFLECTION

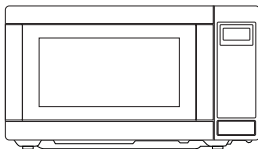

The microwaves bounce off the metal walls and the metal door screen.

### ► ABSORPTION

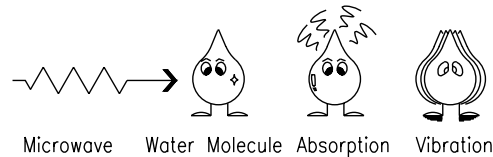

The microwaves cause the water molecules to vibrate which causes **FRICITION**, i.e. **HEAT**. This heat then cooks the food. Microwaves are also attracted to fat and sugar particles, and foods high in these will cook more quickly. Microwaves can only penetrate to a depth of 1½ - 2 inches(4-5cm) and as heat spreads through the food by conduction, just as in a traditional oven, the food cooks from the outside inwards.

## CONVERSION CHARTS

WEIGHT MEASURES		VOLUME MEASURES		SPOON MEASURES	
15 g	1/2 oz.	30 ml	1 fl.oz.	1.25 ml	1/4 tsp
25 g	1 oz.	100 ml	3 fl.oz.	2.5 ml	1/2 tsp
50 g	2 oz.	150 ml	5 fl.oz. (1/4 pt)	5 ml	1 tsp
100 g	4 oz.	300 ml	10 fl.oz. (1/2 pt)	15 ml	1 tbsp
175 g	6 oz.	600 ml	20 fl.oz. (1pt)		
225 g	8 oz.				
450 g	1 lb.				

FLUID MEASUREMENTS		
1 Cup	= 8 fl.oz.	= 240 ml
1 Pint	= 16 fl.oz. (UK 20 fl.oz.)	= 480 ml (UK 560 ml)
1 Quart	= 32 fl.oz. (UK 40 fl.oz.)	= 960 ml (UK 1120 ml)
1 Gallon	= 128 fl.oz. (UK 160 fl.oz.)	= 3840 ml (UK 4500 ml)

# COOKING TECHNIQUES

## STANDING TIME

Dense foods e.g. meat, jacket potatoes and cakes, require standing time (inside or outside of the oven) after cooking, to allow heat to finish conducting to cook the center completely. Wrap meat joints and jacket potatoes in aluminium foil while standing. Meat joints need approx. 10-15 minutes, jacket potatoes 5 minutes. Other foods such as plated meals, vegetables, fish etc require 2-5 minutes standing. After defrosting food, standing time should also be allowed. If food is not cooked after standing time, return to the oven and cook for additional time.

## MOISTURE CONTENT

Many fresh foods e.g. vegetables and fruit, vary in their moisture content throughout the season, particularly jacket potatoes. For this reason cooking times may have to be adjusted. Dry ingredients e.g. rice, pasta, can dry out during storage so cooking times may differ.

## DENSITY

Porous airy foods heat more quickly than dense heavy foods.

## CLING FILM

Cling film helps keep the food moist and the trapped steam assists in speeding up cooking times. Pierce before cooking to allow excess steam to escape. Always take care when removing cling film from a dish as the build-up of steam will be very hot.

## SHAPE

Even shapes cook evenly. Food cooks better by microwave when in a round container rather than square.

## SPACING

Foods cook more quickly and evenly if spaced apart. NEVER pile foods on top of each other.

## STARTING TEMPERATURE

The colder the food, the longer it takes to heat up. Food from a fridge takes longer to reheat than food at room temperature.

## LIQUIDS

All liquids must be stirred before and during heating. Water especially must be stirred before and during heating, to avoid eruption. Do not heat liquids that have previously been boiled. DO NOT OVERHEAT.

## TURNING & STIRRING

Some foods require stirring during cooking. Meat and poultry should be turned after half the cooking time.

## ARRANGING

Individual foods e.g. chicken portions or chops, should be placed on a dish so that the thicker parts are towards the outside.

## QUANTITY

Small quantities cook faster than large quantities, also small meals will reheat more quickly than large portions.

## PIERCING

The skin or membrane on some foods will cause steam to build up during cooking. These foods must be pierced or a strip of skin should be peeled off before cooking to allow the steam to escape. Eggs, potatoes, apples, sausages etc, will all need to be pierced before cooking. DO NOT ATTEMPT TO BOIL EGGS IN THEIR SHELLS.

## COVERING

Cover foods with microwave cling film or a lid. Cover fish, vegetables, casseroles, soups. Do not cover cakes, sauces, jacket potatoes or pastry items.

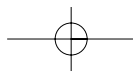

## GENERAL DEFROSTING GUIDE

- Do not defrost covered meat. Covering might allow cooking to take place. Always remove outer wrap and tray. Use only containers that are microwave-safe.
  - Begin defrosting whole poultry breast-side- down. Begin defrosting roasts fat-side-down.
  - The shape of the package alters the defrosting time. Shallow rectangular shapes defrost more quickly than a deep block.
  - After  $\frac{1}{3}$  of the defrost time has elapsed, check the food. You may wish to turn over, break apart, rearrange or remove thawed portions of the food.
  - During defrost, the oven will prompt you to turn the food over. At this point, open oven door and check the food. Follow the techniques listed below for optimum defrost results. Then, close oven door, touch the START pad to complete defrosting.
  - When defrosted, food should be cool, but softened in all areas. If still slightly icy, return to microwave oven very briefly, or let stand a few minutes. After defrosting, allow food to stand 5-60 minutes if there are any icy areas.  
Poultry and fish may be placed under running cool water until defrosted
- ⇒ **Turn over** : Roast, ribs, whole poultry, turkey breasts, hot dogs, sausages, steaks, or chops.
- ⇒ **Rearrange** : Break apart or separate steaks, chops, hamburger patties, ground meat, chicken or seafood pieces, chunks of meat such as stew beef.
- ⇒ **Shield** : Use small strips of aluminum foil to protect thin areas or edges of unevenly shaped foods such as chicken wings. To prevent arching, do not allow foil to come within 1-inch of oven walls or door.
- ⇒ **Remove** : To prevent cooking, thawed portions should be removed from the oven at this point. This may shorten defrost time for food weighing less than 1350g.(3 lbs).

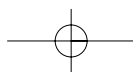

# DEFROSTING CHART

Item and Weight	Defrosting Time	Standing Time	Special Techniques
<b>BEEF</b> Minced beef 1 lb./454g	7-9 min.	15-20 min.	Break apart and remove thawed portions with fork.
Stew Meat 1 1/2 lbs./675g	7-12 min.	25-30 min.	Separate and rearrange once.
Loin Roast 2 lbs./900g	12-15 min.	45-60 min.	Turn over after half the time. Shield as needed.
Patties 4 (4 oz./110g)	5-7 min.	15-20 min.	Turn over after half the time.
<b>LAMB</b> Loin Roast 2 lbs./900g	10-13 min.	45-60 min.	Turn over after half the time. Shield as needed.
Spare ribs 1 lb. 450g	5-6 min.	25-30 min.	Separate and rearrange once.
Chops 4 (5 oz./125g)	5-6 min.	25-30 min.	Separate and turn over once.
Minced 1lb./450g	7-9 min.	15-20 min.	Break apart and remove thawed portions with fork.
<b>POULTRY</b> Whole Chicken 2 1/2 lbs./1125g	13-17 min.	45-90 min.	Breast side down. Turn over after half the time. Shield as needed.
Chicken Breasts 1lb./450g	7-9 min.	15-30 min.	Separate and rearrange once.
Fryer Chicken(cut up) 2lbs./900g	8-10 min.	25-30 min.	Separate and rearrange once.
Chicken Thighs 1 1/2 lbs./675g	10-12 min.	15-30 min.	Separate and rearrange once.
<b>FISH &amp; SEAFOOD</b> Whole Fish 1lb./450g	4-5 min.	15-20 min.	Turn over after half the time. Shield as needed.
Fish Fillets 1 1/2 lb./675g	5-6 min.	15-20 min.	Separate and turn over once.
Shrimp 1/2 lb./225g	2-3 min.	10-15 min.	Separate and rearrange once.

\* The times are approximate because freezer temperatures vary.



# COOKING & REHEATING CHART

Item	Power Level	Cooking Time Per lb./450g		
<b>MEAT</b>				
<b>Beef</b>				
Standing / rolled Rib - Rare	PL-8	6-9 min.		
- Medium	PL-8	8-10 min.		
- well done	PL-8	10-12 min.		
Ground Beef (to brown for casserole)	HIGH	4-6 min.		
Hamburgers, Fresh or defrosted (4oz. Each/100g) 2 patties	HIGH	2-4 min.		
4 patties	HIGH	3-5 min.		
<b>Lamb</b>				
Loin, Leg	PL-8	11-14 min.		
Bacon 4 slices	HIGH	2-3 min.		
6 slices	HIGH	3-4 min.		
<b>NOTE:</b> The above times should be regarded only as a guide, allow for difference in individual tastes and preferences. The times may vary due to the shape, cut, and composition of the meat.				
<b>POULTRY</b>				
<b>Chicken</b>				
Whole	HIGH	6-8 min.		
Breast(boned) portions	PL-8	4-6 min.		
	PL-8	5-7 min.		
<b>Turkey</b>				
Whole	HIGH	10-12 min.		
<b>NOTE :</b> The above times should be regarded only as a guide. Allow for difference in individual tastes and preferences. The times may vary due to the shape, cut, and composition of the food.				
<b>FRESH FISH</b>				
Item	Power Level	Cooking Time Per lb./450g	Method	Standing Time
Fish Fillets	HIGH	3-5 min.	Add 15 - 30 ml (1-2 Tbsp) of water	2-3 min.
Whole Mackerel, Cleaned and Prepared	HIGH	3-5 min.	-	3-4 min.
Whole Trout, Cleaned and Prepared	HIGH	4-6 min.	-	3-4 min.
Salmon Steaks	HIGH	4-6 min.	Add 15 - 30 ml (1-2 Tbsp) of water	3-4 min.
ITEM	POWER LEVEL	Cooking Time	Standing Time	
Lasagna 1 serving(10 1/2 oz./300g)	HIGH	5-7 min.	Place lasagna on microwaveable plate. Cover with plastic wrap and vent.	
Casserole 1 cup	HIGH	1 1/2 -3 min.	Cook covered in microwaveable casserole.	
4 cups	HIGH	5-7 min.	Stir once halfway through cooking.	
Mashed potatoes 1 cup	HIGH	2-3 min.	Cook covered in microwaveable casserole.	
4 cups	HIGH	6-8 min.	Stir once halfway through cooking.	
Baked beans 1 cup	HIGH	2-3 min.	Cook covered in microwaveable casserole. Stir once halfway through cooking.	



ITEM	POWER LEVEL	Cooking Time	Standing Time
Ravioli or pasta in sauce 1 cup 4 cups	HIGH HIGH	3-4 min. 6-9 min.	Cook covered in microwaveable casserole. Stir once halfway through cooking.
Sandwich roll or bun 1 roll	HIGH	20-30 sec.	Wrap in paper towel and place on glass microwaveable rack <b>* Note : Do not use recycled paper towels.</b>

## VEGETABLE CHART

\* Note : Use power level HIGH unless otherwise noted.

VEGETABLES	AMOUNT	TIME	SPECIAL INSTRUCTIONS
<b>Asparagus</b> Fresh spears Frozen spears	1 lb./450g 10-oz./280g package	4-7 min. 3-6 min.	In medium casserole, place 1/4 cup water. In medium casserole.
<b>Beans</b> Fresh green Frozen green Frozen lima	1 lb./450g cut in half 10-oz./280g package 10-oz./280g package	7-12 min. 4-6 min. 3-5 min.	In medium casserole, place 1/2 cup water. In medium casserole, place 2 tbsp water. In medium casserole, place 1/4 cup. Water.
<b>Beets</b> Fresh, whole	1 bunch(1 1/4 -1 1/2 lbs.) /560-680g	12-18 min.	In medium casserole, place 1/2 cup water.
<b>Broccoli</b> Fresh cut Fresh spears Frozen, chopped Frozen spears	1 bunch(1 1/4 -1 1/2 lbs.) /560-680g 1 bunch(1 1/4 -1 1/2 lbs.) /560-680g 10-oz./280g package 10-oz./280g package	3-7 min. 5-9 min. 3-6 min. 3-6 min.	In large casserole, place 1/2 cup water. In large casserole, place 1/2 cup water. In medium casserole. In medium casserole, place 3 tbsp water.
<b>Cabbage</b> Fresh Wedges	1 medium head (about 2 lbs./900g)	5-9 min. 3-7 min.	In large casserole, place 1/4 cup water. In large casserole, place 1/4 cup water.
<b>Carrots</b> fresh, sliced frozen	1 lb./450g 10-oz./280g package	3-7 min. 3-6 min.	In large casserole, place 1/2 cup water. In medium casserole, place 2 tbsp water.
<b>Cauliflower</b> flowerets fresh, whole frozen	1 medium head (about 2 lbs./900g) 1 medium head (about 2 lbs./900g) 10-oz./280g package	5-9 min. 5-12 min. 3-7 min.	In large casserole, place 1/2 cup water. In large casserole, place 1/2 cup water. In medium casserole, place 2 tbsp water.
<b>Corn</b> frozen kernel	10-oz./280g package	2-6 min.	In medium casserole, place 2 tbsp water.
<b>Corn on the cob</b> fresh frozen	1-5 ears 1 ear 2-6 ears	(per ear) 1 1/4 -4min. 1-2 min. 3-6 min.	In large glass baking dish, place corn. If corn is in husk, use no water; if corn has been husked, add 1/4 cup water. Rearrange after half of time. Place in large oblong glass baking dish. Cover with vented plastic wrap. Rearrange after half of time.

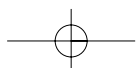



VEGETABLES	AMOUNT	TIME	SPECIAL INSTRUCTIONS
<b>Mixed vegetable</b> frozen	10-oz./280g package	2-6 min.	In medium casserole, place 3 tbsp water.
<b>Peas</b> fresh, shelled frozen	2 lbs.(450g) unshelled 10-oz.(280g) package	7-10 min. 2-6 min.	In medium casserole, place 1/4 cup water. In medium casserole, place 2 tbsp water.
<b>Potatoes</b> fresh, cubed, white	4 potatoes (6-8 oz. /160-220g each)	9-12 min.	Peel and cut into 1-inch cubes. Place in large casserole with 1/2 cup water. Stir after half of time.
fresh, whole, sweet or white	1 (6-8 oz./160-220g)	2-4 min.	Pierce with cooking fork. Place in the oven, 1-inch apart, in circular arrangement. Let stand 5 minutes.
<b>Spinach</b> fresh	10-16 oz./280-450g	3-6 min.	In large casserole, place washed spinach.
frozen, chopped, and leaf	10-oz./280g package	3-6 min.	In medium casserole, place 3 tbsp water.
<b>Squash</b> fresh, summer, and yellow	1 lb./450g sliced.	3-5 min.	In large casserole, place 1/4 cup water. Cut in half and remove fibrous membranes.
winter, acorn, or butternut	1-2 squash (about 1 lb./450g each)	5-9 min.	In large glass baking dish, place squash cut-side-down. Turn cut-side-up after 4 minutes.



# RECIPES

## TOMATO & ORANGE SOUP

1 oz.(25g) butter  
 1 medium onion, chopped  
 1 large carrot & 1 large potato, chopped  
 1<sup>3</sup>/<sub>4</sub>lb(800g) canned, chopped tomatoes  
 juice and grated rind of 1 small orange  
 1<sup>1</sup>/<sub>2</sub>pints(900ml) hot vegetable stock  
 salt and pepper to taste

1. Melt the in a large bowl on HIGH for 1 minute.
2. Add the onion, carrot and potato and cook on HIGH for 6 minutes. stir halfway through cooking.
3. Add the tomatoes, orange juice, orange rind and stock. Mix thoroughly. Season with salt and pepper to taste. Cover the bowl and cook on HIGH for 13 minutes. stir 2-3 times during cooking, until the vegetables are tender.
4. Blend and serve immediately.

## FRENCH ONION SOUP

1 large onions, sliced  
 1 tbsp (15ml) corn oil  
 2 oz.(50g) plain flour  
 2 pints(1.2 liters) hot meat  
 or vegetable stock  
 salt and pepper to taste  
 2 tbsp (30ml) parsley, chopped  
 4 thick slices French bread  
 2 oz.(50g) cheese, grated

1. Place the onion and oil a bowl, mix well and cook on HIGH for 2 minutes.
2. Stir in the flour to make a paste and gradually add stock. Season and add the parsley.
3. Cover the bowl and cook on PL-7 for 15 minutes.
4. Pour the soup into serving bowls, submerge bread and sprinkle generously with cheese.
5. Cook on PL-7 for 2 minutes, until the cheese has melted.

## STIR FRIED VEGETABLES

1 tbsp(15ml) sunflower oil  
 2 tbsp (30ml) soy sauce  
 1 tbsp (15ml) sherry  
 1"(2.5cm) root ginger,  
 peeled and finely grated  
 2 medium carrots, cut into fine strips  
 4 oz.(100g) button mushrooms,  
 chopped  
 2 oz.(50g) beansprouts  
 4 oz.(100g) mange-tout  
 1 red pepper, seeded and thinly sliced  
 4 spring onions, chopped  
 4 oz.(100g) canned water chestnuts,  
 sliced  
 1/4 head of chinese leaves, thinly sliced

1. Place the oil, soy sauce, sherry, ginger, garlic and carrots in a large bowl, mix thoroughly
2. Cover and cook on HIGH for 3-4 minutes, stirring once.
3. Add the button mushrooms, beansprouts, mange-tout, red pepper, spring onions, water chestnuts and chinese leaves. Mix thoroughly.
4. Cook on HIGH for 5-6 minutes, until the vegetables are tender. Stir 2-3 times during cooking.

***Stir fried vegetables are ideally served with meat or fish.***

## HONEYED CHICKEN

4 boneless chicken breasts  
 2 tbsp(30ml) clear honey  
 1 tbsp(15ml) whole grain mustard  
 1/2 tsp(2.5ml) dried tarragon  
 1 tbsp(15ml) tomato puree  
 1/4 pint(150ml) chicken stock

1. Place the chicken breasts in a casserole dish.
2. Mix all remaining ingredients together and pour over the chicken. Salt and pepper to taste.
3. Cook on HIGH for 13-14 minutes. Rearrange and coat the chicken with the sauce twice during cooking.

## BLUE CHEESE & CHIVE JACKETS

2 baking potatoes,  
(approx.9 oz.(250g) each)  
2 oz.(50g) butter  
4 oz.(100g) blue cheese, chopped  
1 tbsp(15ml) fresh chives, chopped  
2 oz.(50g) mushrooms, sliced  
salt and pepper to taste

1. Pierce each potato in several places. Cook on HIGH for 10-12 minutes. Halve and scoop the flesh into a bowl, add the butter, cheese, chives, mushrooms, salt and pepper, mix thoroughly.
2. Pile mixture into the potato skins and place in a flan dish, on the rack.
3. Cook on PL-5 for 8 minutes.

## WHITE SAUCE

1 oz.(25g) butter  
1 oz.(25g) plain flour  
1/2 pint(300ml) milk  
salt and pepper to taste

1. Place the butter in a bowl and cook on HIGH for 1 minute, until melted.
2. Stir in the flour and whisk in the milk. Cook on HIGH for 3-4 minutes, stirring every 2 minutes until thick and smooth. Season with salt and pepper to taste.

## STRAWBERRY JAM

1 1/2 lb.(675g) strawberries, hulled  
3 tbsp(45ml) lemon juice  
1 1/2 lb.(675g) caster sugar

1. Place strawberries and lemon juice in a very large bowl, heat on HIGH for 5 minutes, or until the fruit has softened. Add sugar, mix well.
2. Cook on PL-7 for 20-25 minutes, until setting point\* is reached, stir every 4-5 minutes.
3. Pour into hot, clean jars. Cover, seal and label.

*\* setting point : To determine setting point, place 1 tsp(5ml) jam onto chilled saucer. Allow to stand for 1 minute. Move surface of jam gently with your finger, if the surface wrinkles setting point has been reached.*

## PLAIN MICROWAVE CAKE

4 oz.(100g) margarine  
4 oz.(100g) sugar  
1 eggs  
4 oz.(100g) self raising flour, sifted  
2-3 tbsp(30-45ml) milk

1. line the base of 8" (20.4cm) cake dish with grease-proof paper.
2. Cream the margarine and sugar together until light and fluffy. Beat in the eggs and fold in the sifted flour alternately with the milk.
3. Pour into prepared container. Cook on HIGH for 4-5 minutes, until a skewer comes out cleanly.
4. Leave the cake to stand for 5 minutes before turning out.

## OMELETTES

1/2 oz.(15g) butter  
4 eggs  
6 tbsp(90ml) milk  
salt & pepper

1. Whisk together eggs and milk. Season.
2. Place butter in 10"(26cm) flan dish. Cook on HIGH for 1 minute, until melted. Coat the dish with the melted butter.
3. Pour omelette mixture into flan dish. Cook on HIGH for 2 minutes. whisk mixture and cook again on HIGH for 1 minutes.

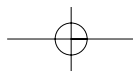

### **SCRAMBLED EGG**

1/2 oz.(15g) butter  
2 eggs  
2 tbsp(30ml) milk  
salt & pepper

1. Melt the butter in a bowl on HIGH for 1 minute.
2. Add the eggs, milk and seasoning and mix well.
3. Cook on HIGH for 3 minutes, stirring every 30 seconds.

### **SAVOURY MINCE**

1 small onion, diced  
1 clove garlic, crushed  
1 tsp(5ml) oil  
7 oz.(200g) can chopped tomatoes  
1 tbsp(15ml) tomato puree  
1 tsp(5ml) mixed herbs  
8 oz.(225g) minced beef  
salt and pepper

1. Place onion, garlic and oil in casserole, and cook on HIGH for 2 minutes or until soft.
2. Place all other ingredients in casserole. Stir well.
3. Cover and cook on HIGH for 3 minutes then PL-5 for 10-15 minutes or until the meat is cooked.

