

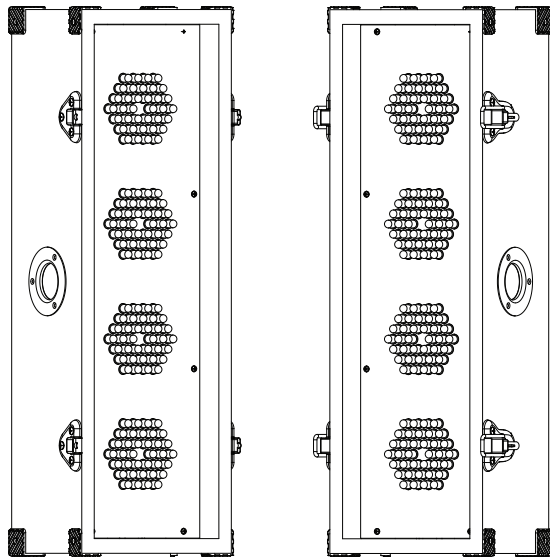

# FLASHBACK 4



## *User Instructions*

©2013 ADJ Products, LLC all rights reserved. Information, specifications, diagrams, images, and instructions herein are subject to change without notice. ADJ Products, LLC logo and identifying product names and numbers herein are trademarks of ADJ Products, LLC. Copyright protection claimed includes all forms and matters of copyrightable materials and information now allowed by statutory or judicial law or hereinafter granted. Product names used in this document may be trademarks or registered trademarks of their respective companies and are hereby acknowledged. All non-ADJ Products, LLC brands and product names are trademarks or registered trademarks of their respective companies.

**ADJ Products, LLC** and all affiliated companies hereby disclaim any and all liabilities for property, equipment, building, and electrical damages, injuries to any persons, and direct or indirect economic loss associated with the use or reliance of any information contained within this document, and/or as a result of the improper, unsafe, insufficient and negligent assembly, installation, rigging, and operation of this product.

Europe Energy Saving Notice

Energy Saving Matters (EuP 2009/125/EC)

Saving electric energy is a key to help protecting the environment. Please turn off all electrical products when they are not in use. To avoid power consumption in idle mode, disconnect all electrical equipment from power when not in use. Thank you!

## Flashback 4

## Introduction

### **Introduction:**

Thank you for purchasing the ADJ Flashback 4. To optimize the performance of this product, please read these operating instructions carefully to familiarize yourself with the basic operations of this unit.

### **Customer Support:**

ADJ Products, LLC provides a toll free customer support line, to provide set up help and to answer any question should you encounter problems during your set up or initial operation. You may also visit us on the web at [www.adj.com](http://www.adj.com) for any comments or suggestions.

Service Hours are Monday through Friday 8:00 a.m. to 4:30 p.m. Pacific Standard Time.

Voice: (800) 322-6337

Fax: (323) 582-2941

E-mail: [support@americandj.com](mailto:support@americandj.com)

**Warning!** To prevent or reduce the risk of electrical shock or fire, do not expose this unit to rain or moisture.

**Caution!** There are no user serviceable parts inside this unit. Do not attempt any repairs yourself, doing so will void your manufacturer's warranty. In the unlikely event your unit may require service please contact ADJ Products, LLC.

Do not discard the shipping carton in the trash. Please recycle when ever possible.

## Flashback 4

## General Instructions

To optimize the performance of this product, please read these operating instructions carefully to familiarize yourself with the basic operations of this unit. These instructions contain important safety information regarding the use and maintenance of this unit. Please keep this manual with the unit, for future reference.

## Flashback 4

## Features

- Stand Mountable (Tripod Stands not included)
- Includes 2 pole mounts for vertical and horizontal mounting
- 11 Programs: 6 Chases, 4 Flashing, and 1 Mixed Pattern
- Auto Run or Sound Active

## Flashback 4

## Warranty Registration

The Flashback 4 carries a two year (730 days) limited warranty. Please fill out the enclosed warranty card to validate your purchase. All returned service items whether under warranty or not, must be freight pre-paid and accompany a return authorization (R.A.) number. The R.A. number must be clearly written on the outside of the return package. A brief description of the problem as well as the R.A. number must also be written down on a piece of paper and included in the shipping container. If the unit is under warranty, you must provide a copy of your proof of purchase invoice. You may obtain a R.A. number by contacting customer support at (800) 322-6337.

## Flashback 4

## Operation

**Introduction:** The ADJ Flashback 4 is a 4 cluster LED effect. This fixture is designed for mobile DJ's, clubs, bands, roller rinks and any arena that requires a compact, light weight, easy to use unit.

**General Operation:** This fixture is designed to operate in a master-slave configuration. Connect the units to one another using the provided 5 pin cable. Plug the unit in to a matching power outlet and turn the program knob to your desired show. Use the Audio/Speed adjustment knob to adjust the program speed. The list of programs follow:

OFF - Blackout

MIX - Mixed Patterns

C1 - Pattern 1: Single Color Changing

C2 - Pattern 2: Two Color Changing

C3 - Pattern 3: Color Changing with Fade Out

C4 - Pattern 4: Single Color Changing with Fade Out

C5 - Pattern 5: Fast Paced

C6 - Pattern 6: Slow

F4 - Flash 4: Left and Right Single Flash

F3 - Flash 3: Four Time Flash

F2 - Flash 2: Twice Flash

F1 - Flash 1: One Flash

To activate sound active mode, turn the Audio/Speed knob all the way counter-clockwise until you hear a "click". When you hear the "click" you are in sound active mode.

## Flashback 4

## Controls and Functions

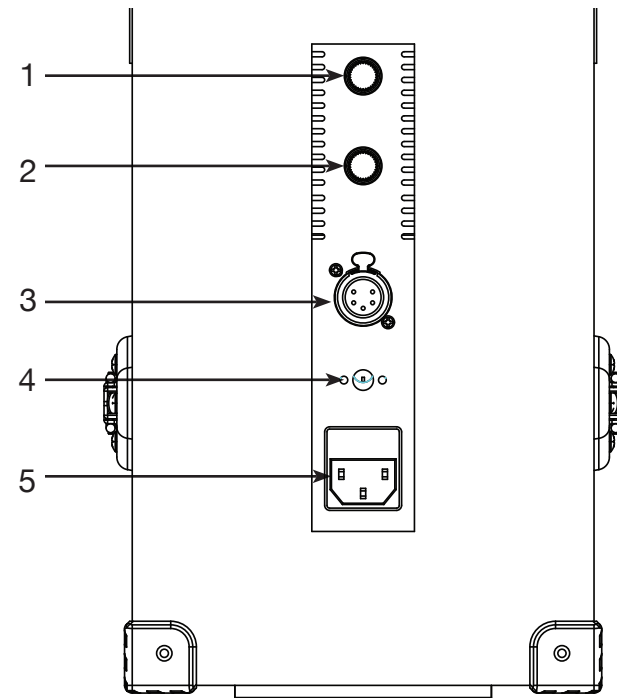

1. Sound Sensitivity/Program Speed Adjustment.
2. Program Knob.
3. 5-pin Slave connection jack.
4. DC Power Supply
5. AC Power Supply and Fuse Holder.

## Flashback 4

## Mounting

The unit should be mounted on a secure stand (not provided). Always ensure that the unit is firmly fixed to avoid vibration and slipping while operating. Always ensure that the structure to which you are mounting the unit to is secure and is able to support a weight of 10 times the unit's weight. The unit can be mounted vertical or horizontal.



## Flashback 4

## Fuse Replacement

Locate and remove the unit's power cord. Once the cord has been removed locate the fuse holder located inside the power socket. Insert a flat-head screw driver into the power socket and gently pry out the fuse holder. Remove the bad fuse and replace with a new one. The fuse holder has a built-in socket for a spare fuse be sure not to confuse the spare fuse with active fuse.

## Flashback 4

## Trouble Shooting

**Trouble Shooting:** Listed below are a few common problems that you may encounter, with solutions.

No light output from the unit;

1. Be sure the fuse has not blown. The fuse is located on the rear panel.

Unit does not respond to sound;

1. Low frequencies (bass) should cause the unit to react to sound. Tapping on the microphone, quiet or high pitched sounds may not activate the unit.

## Flashback 4

## Cleaning

**Fixture Cleaning:** Due to fog residue, smoke, and dust cleaning the internal and external optical lenses must be carried out periodically to optimize light output.

1. Use normal glass cleaner and a soft cloth to wipe down the outside casing.
2. Clean the external optics with glass cleaner and a soft cloth every 20 days.
3. Clean the internal optics with glass cleaner and a soft cloth every 30-60 days.
4. Always be sure to dry all parts completely before plugging the unit back in.

Cleaning frequency depends on the environment in which the fixture operates (I.e. smoke, fog residue, dust, dew). In heavy club use we recommend cleaning on a monthly basis. Periodic cleaning will ensure longevity, and crisp output.

## MANUFACTURER'S LIMITED WARRANTY

- A. ADJ Products, LLC hereby warrants, to the original purchaser, ADJ Products, LLC products to be free of manufacturing defects in material and workmanship for a prescribed period from the date of purchase (see specific warranty period on reverse). This warranty shall be valid only if the product is purchased within the United States of America, including possessions and territories. It is the owner's responsibility to establish the date and place of purchase by acceptable evidence, at the time service is sought.
- B. **For warranty service you must obtain a Return Authorization number (RA#) before sending back the product—please contact ADJ Products, LLC Service Department at 800-322-6337.** Send the product only to the ADJ Products, LLC factory. All shipping charges must be pre-paid. If the requested repairs or service (including parts replacement) are within the terms of this warranty, ADJ Products, LLC will pay return shipping charges only to a designated point within the United States. If the entire instrument is sent, it must be shipped in its original package. No accessories should be shipped with the product. If any accessories are shipped with the product, ADJ Products, LLC shall have no liability whatsoever for loss of or damage to any such accessories, nor for the safe return thereof.
- C. This warranty is void if the serial number has been altered or removed; if the product is modified in any manner which ADJ Products, LLC concludes, after inspection, affects the reliability of the product; if the product has been repaired or serviced by anyone other than the ADJ Products, LLC factory unless prior written authorization was issued to purchaser by ADJ Products, LLC; if the product is damaged because not properly maintained as set forth in the instruction manual.
- D. This is not a service contract, and this warranty does not include maintenance, cleaning or periodic check up. During the period specified above, ADJ Products, LLC will replace defective parts at its expense with new or refurbished parts, and will absorb all expenses for warranty service and repair labor by reason of defects in material or workmanship. The sole responsibility of ADJ Products, LLC under this warranty shall be limited to the repair of the product, or replacement thereof, including parts, at the sole discretion of ADJ Products, LLC. All products covered by this warranty were manufactured after August 15, 2012, and bear indentifying marks to that effect.
- E. ADJ Products, LLC reserves the right to make changes in design and/or improvements upon its products without any obligation to include these changes in any products theretofore manufactured.

No warranty, whether expressed or implied, is given or made with respect to any accessory supplied with products described above. Except to the extent prohibited by applicable law, all implied warranties made by ADJ Products, LLC in connection with this product, including warranties of merchantability or fitness, are limited in duration to the warranty period set forth above. And no warranties, whether expressed or implied, including warranties of merchantability or fitness, shall apply to this product after said period has expired. The consumer's and/or Dealer's sole remedy shall be such repair or replacement as is expressly provided above; and under no circumstances shall ADJ Products, LLC be liable for any loss or damage, direct or consequential, arising out of the use of, or inability to use, this product.

This warranty is the only written warranty applicable to ADJ Products, LLC Products and supersedes all prior warranties and written descriptions of warranty terms and conditions heretofore published.

## MANUFACTURER'S LIMITED WARRANTY PERIODS:

- **Lighting Products = 1-year (365 days) Limited Warranty** (Such as: Special Effect Lighting, Intelligent Lighting, UV lighting, Strobes, Fog Machines, Bubble Machines, Mirror Balls, Par Cans, Trussing, Lighting Stands etc. excluding LEDs and lamps)
- **Laser Products = 90-Day Limited Warranty**
- **L.E.D. Products = 2-year (730 days) Limited Warranty** (excluding motors, PCB boards, and power supplies, which have a 1-year (365 day Limited Warranty) and batteries which have a 180 day limited warranty). Only the L.E.D.s carry a 3-year warranty

## Technical Specifications:

Model: Flashback 4

<b>Voltage:</b>	100v~240v 50Hz~60Hz DC Input 12V / 2A
<b>LEDs:</b>	288 x 10mm LEDs (72 Red, 72 Green, 72 Blue, & 72 Amber)
<b>Beam Angle:</b>	45 Degrees
<b>Power Consumption:</b>	23W
<b>Dimensions:</b>	22.5" (L) x 7.5" (W) x 11" (H) 568 x 192 x 280mm
<b>Weight:</b>	16 Lbs./6.9 Kgs.
<b>Fuse:</b>	1 Amp
<b>Colors:</b>	RGBA
<b>Duty Cycle:</b>	None
<b>Operating Mode:</b>	Sound Active
<b>Warranty:</b>	2 Years (730 Days)

**Auto Sensing Voltage:** This fixture contains a automatic voltage switch, which will auto sense the voltage when it is plugged into the power source.

**Please Note:** Specifications and improvements in the design of this unit and this manual are subject to change without any prior written notice.

ADJ Products, LLC  
6122 S. Eastern Ave. Los Angeles, CA 90040 USA  
Tel: 323-582-2650 / Fax: 323-725-6100  
Web: [www.adj.com](http://www.adj.com) / E-mail: [info@americandj.com](mailto:info@americandj.com)

A.D.J. Supply Europe B.V.  
Junostraat 2  
6468 EW Kerkrade  
Netherlands

Follow Us On:



[facebook.com/americandj](https://facebook.com/americandj)  
[twitter.com/americandj](https://twitter.com/americandj)  
[youtube.com/adjlighting](https://youtube.com/adjlighting)

[service@adjgroup.eu](mailto:service@adjgroup.eu) / [www.adj.eu](http://www.adj.eu)  
Tel: +31 45 546 85 00 / Fax: +31 45 546 85 99