



Since 1977

Energy efficiency & MAXimum performance

Operating Instructions

GAS POWERED PISTON COMPRESSORS

*EMAX designs and manufactures products for safe operation. However, operators and maintenance persons are responsible for maintaining safety. All safety precautions are included to provide a guideline for minimizing the possibility of accidents and property damage while equipment is in operation. **Keep these instructions for reference.***

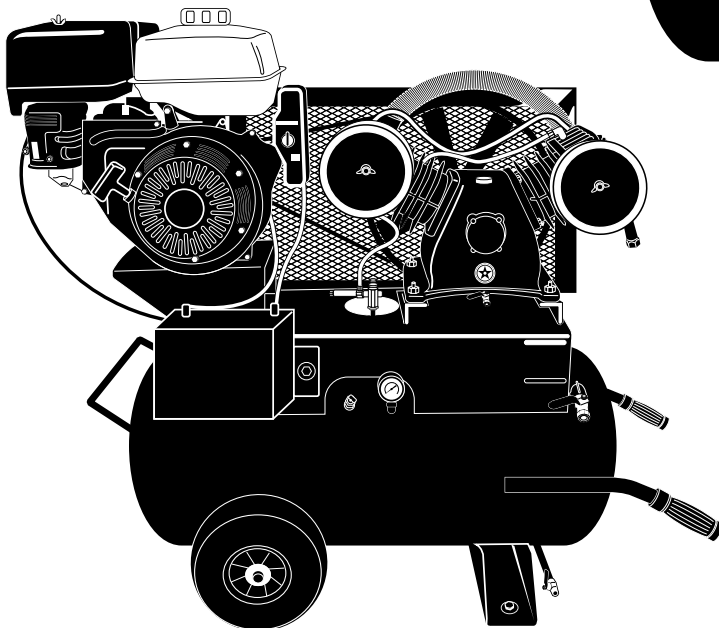
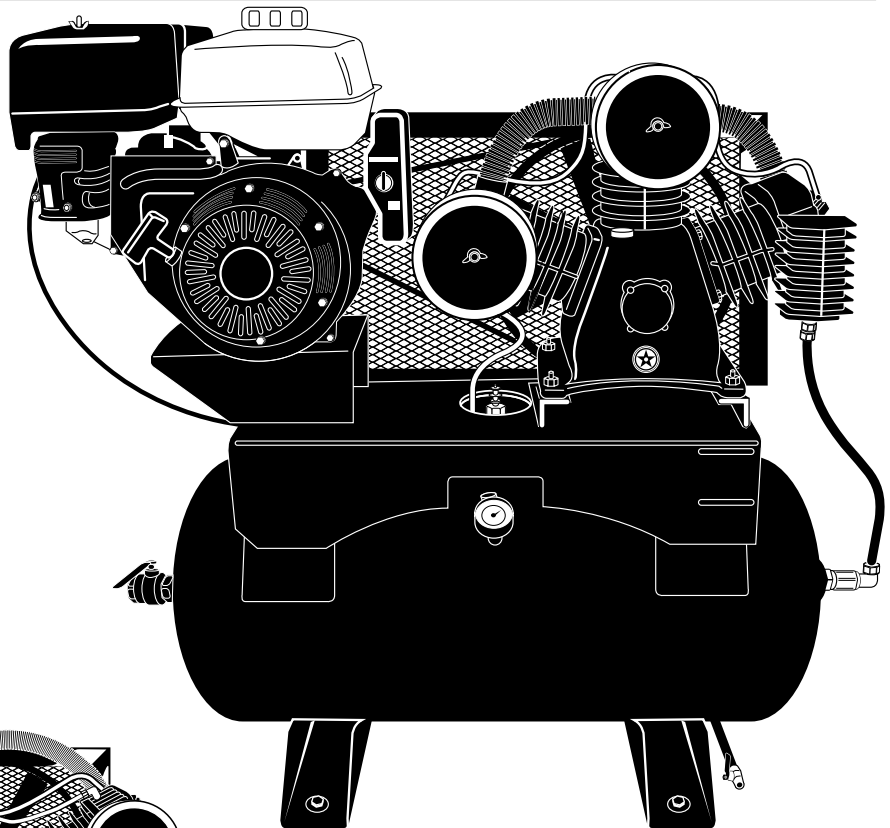

Contents

	Page No.		Page No.
Model Specification Chart	2	Operation	6
Description	3	Safety Rules	6
Safety Information	3	Start Up	7
Tag Definitions	3	Maintenance	8
Basic Guidelines	3	Safety Steps	8
Breathable Air	4	Belt Adjustment	8
Pressurized Components	4	Changing Oil	8
Personal Protective Equipment	4	Safety Valve	9
Inspection	4	Tank	9
Forklift Safety	4	Maintenance Schedule	9
Lifting Safety	4	Troubleshooting	10-11
Installation	5	Warranty	12
Area	5		
Piping Safety Steps	5		
Piping / Tank Installation	5		
Truck Installation	6		
Battery Component	6		

EMAX Gas Powered, Piston Air Compressors

Model	EGPS0817WL	EGES0817WL	EGES1330ST	EGES1830ST	EGES1860ST	EGES2480ST
Description	8 HP HONDA PORTABLE	8 HP HONDA	13 HP, 30 GAL. HONDA	18 HP, 30 GAL. HONDA	18 HP, 60 GAL. HONDA	24 HP, 80 GAL. HONDA
SCFM	18 @ 150	18 @ 150	24 @ 175	34 @ 175	34 @ 175	52 @ 175
Motor Power	8HP	8HP	13HP	18HP	18HP	24HP
Motor RPM	3200	3200	3200	3200	3200	3200
Tank Size	17	17	30	30	60	80
Pump Model	APP2V0732S	APP2V0732S	APP3Y0732T	APP4V1043T	APP4V1043T	APP3Y2062T
Pump RPM	650	650	820	800	800	640
Outlet Size	3/4"	3/4"	3/4"	3/4"	3/4"	1"
Dimensions ^{L*W*H} (inches)	46"x 21"x 37"	46"x 21"x 37"	51"x 23"x 40"	44"x 23"x 44"	51" x 23"x 50"	72"x 25"x 50"
Weight (lbs.)	275	275	395	540	610	870
Shipping Weight	310	310	326	628	703	970
Electric Start	No	Yes	Yes	Yes	Yes	Yes

Description

*Unit configuration and appearance varies by model.
Callouts are for general identification.*

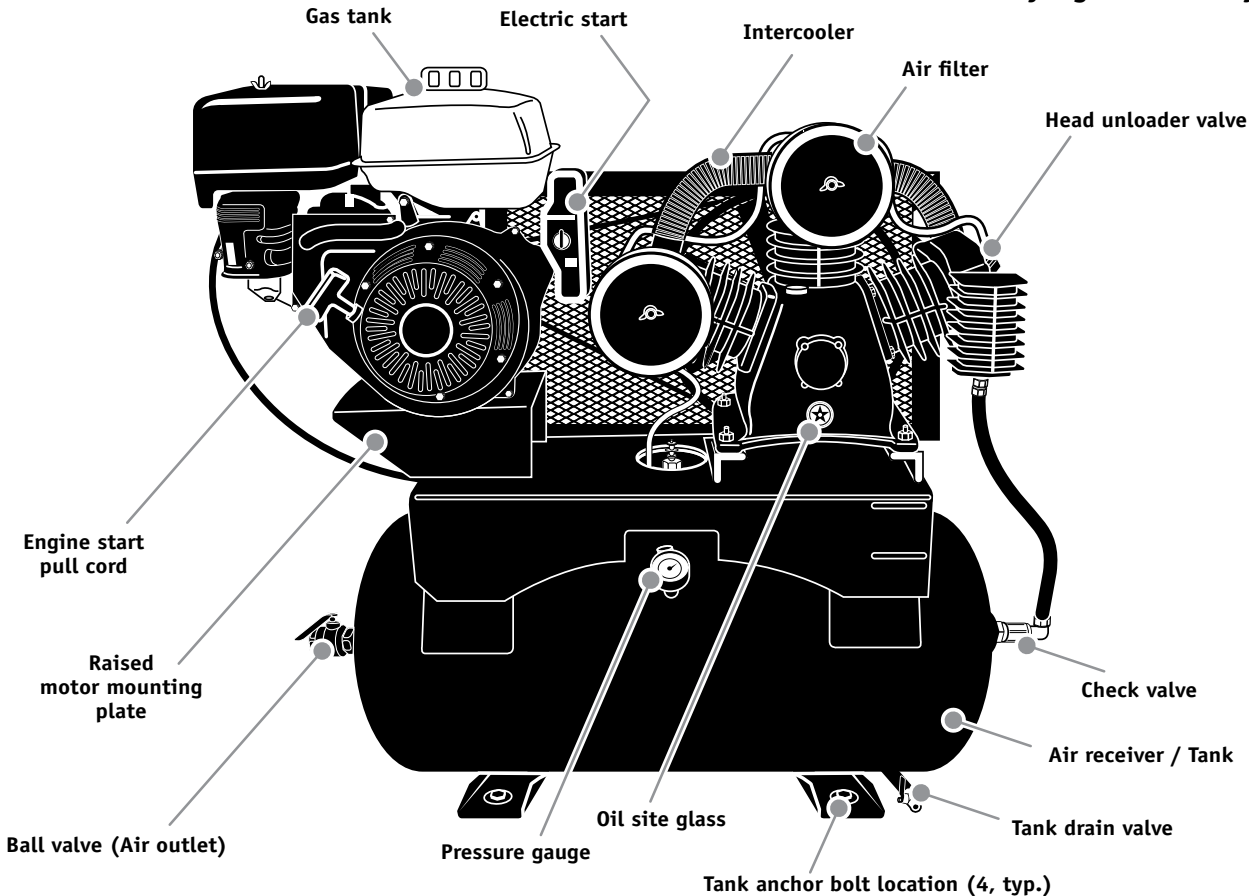

Safety

This manual contains very important information to know and understand. This is provided for SAFETY and to PREVENT EQUIPMENT PROBLEMS. To help understand this information, observe the following:

▲ DANGER Danger indicates an imminently hazardous situation which, if not avoided, *will* result in death or serious injury.

▲ WARNING Warning indicates a potentially hazardous situation which, if not avoided, *could* result in death or serious injury.

▲ CAUTION Caution indicates a potentially hazardous situation which, if not avoided, *may* result in minor or moderate injury.

NOTICE Notice indicates important information, that if not followed, may cause damage to equipment.



Read all manuals included with this product carefully. Be thoroughly familiar with the controls and the proper use of the equipment.

Basic Guidelines

1. Allow only trained, authorized persons who have read and understood these operating instructions to use this compressor. Failure to follow the instructions, procedures and safety precautions in this manual can result in accidents and injuries.
2. NEVER start or operate the compressor under unsafe conditions. Tag the compressor, disconnect and lock out all power to it to prevent accidental start-up until the condition is corrected.
3. Install, use and operate the compressor only in full compliance with all pertinent OSHA regulations and all applicable Federal, State & Local Codes, standards and regulations.
4. NEVER modify the compressor and/or controls in any way.
5. Keep a first aid kit in a convenient place. Seek medical assistance promptly in case of injury. Avoid infection by caring for any small cuts and burns promptly.

Breathable Air

1. NEVER use air from this compressor for breathable air except in full compliance with OSHA Standards 29 CFR 1910 and any other Federal, State or Local codes or regulations.

⚠ DANGER



Death or serious injury can result from inhaling compressed air without using proper safety equipment. See OSHA standards on safety equipment.

2. DO NOT use air line anti-icer systems in air lines supplying respirators or other equipment used to produce breathable air. DO NOT discharge air from these systems in unventilated or other confined areas.

Pressurized Components

This equipment is supplied with a ASME designed pressure vessel protected by an ASME rated relief valve. Pull the ring *before each use* to make sure the valve is functional. Refer to figure _____. DO NOT attempt to open valve while the machine is under pressure.

Personal Protective Equipment

Be sure all operators and others around the compressor and its controls comply with all applicable OSHA, Federal, State and Local regulations, codes and standards relating to personal protective equipment. This includes respiratory protective equipment, protection for the extremities, protective clothing, protective shields and barriers, electrical protective equipment, and personal hearing protective equipment.

Inspection

⚠ WARNING



Inspect compressor prior to any use. Check for external damage that might have occurred during transit. *Be careful of moving parts* then test pulley by turning it freely by hand. **Report any damage to delivery carrier immediately.**

⚠ CAUTION

Make sure pallet-mounted compressors are firmly secured to the pallet before moving. NEVER attempt to move a compressor that is not secure as serious injury or property damage could occur.

A forklift may be necessary for unloading the EMAX compressor. Use all forklift safety measures and require a certified forklift operator. Refer to figure 1 for safe unloading procedure.

Forklift Safety

1. Make sure lift operator stays aware while moving compressor.
2. Be sure load is secure and well balanced before moving the compressor.
3. Make sure forks are fully engaged and level before lifting or moving compressor.
4. Keep load as low as possible and observe safe operating practices.

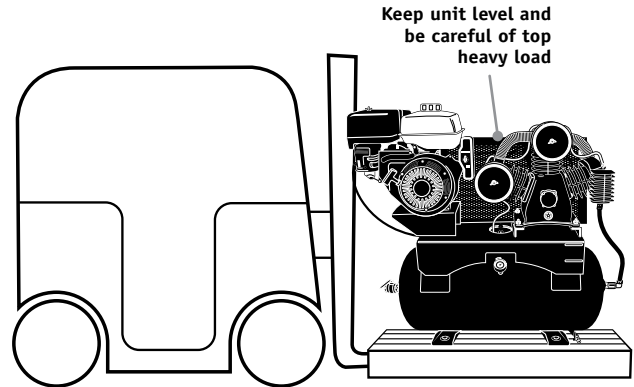

Figure 1: Keep unit level

Lifting Safety

1. Carefully inspect all lifting equipment and make sure it is in good condition. Rated capacity should exceed compressor weight. Make sure lifting hook has a functional safety latch or equivalent and is properly attached to lifting feature.
2. Make sure lifting points are in good condition and tighten any loose nuts or bolts before lifting.
3. Use provided lifting feature or appropriate sling. A sling must be used when moving compressor with a helicopter or other air-borne equipment. Be sure to follow OSHA standards 29 CFR 1910 Subpart N.
4. Use guide ropes or equivalent to prevent twisting or swinging of the compressor while it is in the air and NEVER attempt to lift in high winds. Keep compressor as low to the ground as possible.
5. Keep persons away and make sure no one is under the compressor while it is lifted.
6. Only use lifting features provided for entire compressor package. NEVER use bolts or other hooks on individual components to move the compressor.
7. Make sure to put compressor on a level surface that can support the weight of the compressor and loading equipment.

⚠ WARNING

Do not operate unit if damaged during shipping, handling or use.

Damage may result in bursting and cause injury or property damage.

Installation

Area

1. Install compressor in a clean, dry and well-lit area. Be sure installation area can maintain a temperature range between 35° - 110° F.

CAUTION *If ambient temperature drops below 32°F, be sure to protect safety/relief valves and drain valves from freezing. NEVER operate compressor with temperatures below 15°F or above 125°F.*

2. Allow sufficient space around compressor for maintenance access and adequate airflow. Mount unit with pulley towards wall and leave a minimum of 15 inches of clearance.
3. Use shims to level compressor if installation area is not flat. This will avoid excessive vibration and premature pump wear.

DANGER *DO NOT install compressor in boiler room, paint spray room, or area where sandblasting occurs. Make sure inlet air is away from exhaust fumes or other toxic, noxious or corrosive fumes or substances.*



4. If acid is used in operating environment or air is dust laden, pipe intake to outside, fresh air. Increase pipe size by one size for every 20 feet of run. Be sure to install protective hood around intake filter.
5. Insulate cold water or other low temperature pipes that pass overhead to avoid condensation dripping on compressor which could cause property damage.

Piping

Safety Steps

1. Install appropriate flow-limiting valves as necessary according to pipe size(s) used and run lengths. This will reduce pressure in case of hose failure, per OSHA Standard 29 CFR 1926.302(b)(7).
2. Flow-limiting valves are listed by pipe size and rated CFM. Select appropriate valves accordingly, in accordance with the manufacturer's recommendations.

Piping / Tank Installation

1. Place tank feet on 1/4" thick rubber pads.

Minimum Pipe Size For Compressed Air Lines (Pipe size shown in inches)

SCFM	Length Of Piping System			
	25 ft.	50 ft.	100 ft.	250 ft.
20	3/4	3/4	3/4	1
40	3/4	1	1	1
60	3/4	1	1	1
100	1	1	1	1-1/4

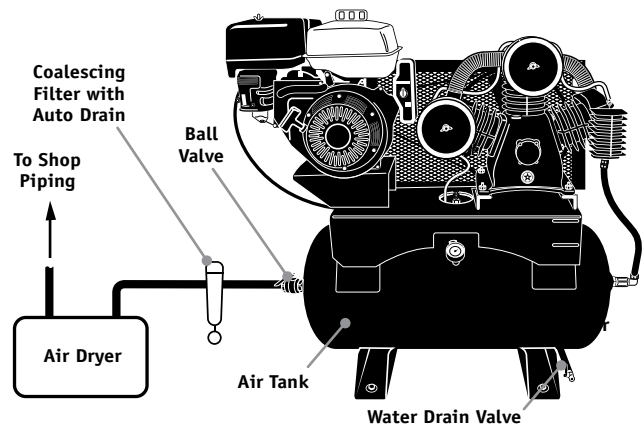

Figure 2: Basic Piping Diagram

Thicker padding will increase vibration and the possibility of cracking the tank or other unit damage. **Do not place unit on dirt floor or uneven surface.**

2. Fasten anchor bolts snugly but do not overtighten so normal vibration will not damage unit.

DANGER *Compressor unit is top heavy and must be bolted to solid, flat surface to avoid falling and premature pump wear. Splash lubrication will not operate properly if unit is not level.*

3. Use a flexible connector between compressor tank and piping system to minimize noise, vibration, unit damage, and pump wear.
4. Install appropriate ASME code safety valves and make sure piping system is equipped with adequate condensate drains. See figure 2.

WARNING *Never install a shut-off valve such as a glove or gate valve, between the pump discharge and the air tank unless a safety valve is installed in the line between valve and pump.*



5. Make sure any tube, pipe or hose connected to the unit can withstand operating temperatures and retain pressure.

▲ WARNING *Never use plastic (PVC) pipe for compressed air. Serious injury or death could result.*

6. Never use reducers in discharge piping. Keep all piping and fittings the same size in the piping system.
7. For permanent installations of compressed air systems, determine total length of system and select correct pipe size. Make sure underground lines are buried below frost line and avoid areas where condensation could build up and freeze.
8. Test entire piping system *before* underground lines are buried. Be sure to find and repair all leaks before using compressor.

▲ WARNING *Never exceed recommended pressure or speed while operating compressor.*

Truck Installation

Compressor can be installed in a truck for convenience and portability. Be sure to follow these additional safety precautions:

1. Bolt compressor to truck bed with 1/4" thick rubber pads under tank feet. Thicker padding will increase vibration and the possibility of cracking the tank or other unit damage.
2. Portable compressors must be secured during transport and while operating to avoid unit damage.

▲ DANGER *If installation is in a box truck or other enclosed area, be sure to vent exhaust fumes away from operating area. Gasoline powered motors will develop hydro-carbons which can be fatal if inhaled.*

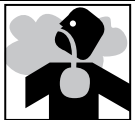

Battery Component

Most EMax compressors are equipped with an electric starter but require a customer supplied, 12V battery for operation. Be sure to follow safety steps and use proper procedures when connecting battery.

Safety Steps

▲ WARNING *Batteries contain caustic acid. Use extreme care when handling to avoid contact with battery acid. If contact occurs, flush immediately with water then use baking soda to neutralize.*



1. Wear eye protection at all times when handling battery.
2. Batteries can give off explosive gases. NEVER

smoke or install battery near sparks or other ignition sources.

▲ CAUTION *NEVER touch both battery terminals at the same time with hands or any non-insulated tools. Always follow proper sequence for connecting and disconnecting battery.*



Connecting Battery

1. Use minimum 10 AWG wire for battery cables.
2. Connect positive (+) cable to start solenoid on engine.
3. Connect negative (-) cable to one of the engine bolts.
4. Connect other end of positive (+) cable to positive (+) battery terminal.
5. Connect other end of negative (-) cable to negative (-) battery terminal.

Disconnecting Battery

1. Disconnect negative (-) cable from negative (-) battery terminal first.
2. Then disconnect positive (+) cable from positive (+) battery terminal.

Operation

Safety Rules

1. Make sure all operators receive product training, read and understand all instructions.

▲ WARNING *Keep all flammable, combustible, poisonous and noxious materials away from operating area. Make sure there are no oily rags, trash, leaves, litter or other combustible materials in operating area. Keep suitable, fully charged fire extinguishers nearby when servicing and operating the compressor.*



2. NEVER allow modifications to compressor structure or controls.
3. Keep all ignition sources away from exposed electrical parts.
4. Keep all persons clear of compressor during start-up and operation.
5. NEVER operate the compressor with the fan, coupling or other guards removed.
6. DO NOT engage in horseplay with air hoses as death or serious injury may result.

7. Make sure to provide adequate ventilation and use proper lubricant while operating the compressor. If lubricant or other combustible substances are spilled, clean up immediately.
8. When checking or adding lubricant or when refilling air line anti-icer systems with antifreeze compound, shut off compressor and allow it to cool. Keep sparks, flames and other ignition sources away and DO NOT permit smoking in the vicinity.
9. Stop compressor and disconnect power if a hazardous condition arises.
10. Wear snug fitting clothing and confine long hair when around compressor. Keep all body parts and clothing away from couplings, flywheel and other moving parts of the equipment.

▲ WARNING *Keep all persons away from the discharge opening of hoses or tools or other points of compressed air discharge. If the machine is installed in an enclosed area, be sure to vent the relief valve outside of the structure or to an unoccupied area.*



11. DO NOT use air tools that are rated below the maximum rating of the compressor. Select air tools, air hoses, pipes, valves, filters and other fittings accordingly. DO NOT exceed manufacturer's rated safe operating pressures for these items.
12. Make sure all hose connections are adequately secured to prevent tools or hose ends from being accidentally disconnected.

▲ CAUTION *Thoroughly read and understand engine owner's manual. Be sure to follow manufacturer's safety precautions and proper operating procedures.*



Start-Up

1. This unit is shipped with pump break-in oil and should be ready to operate. Be sure to check for proper oil level before operating the compressor. Oil should be in center of site glass. See figure 3.



Figure 3: Check proper oil level

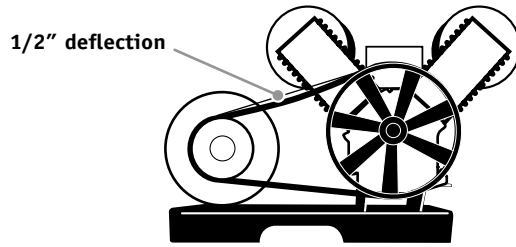

Figure 4: Proper belt tension

NOTICE *Use only Airbase Industries oil (PN: AP0L03000G1). Use of any other product will cause product damage and void the warranty.*

2. Check for proper belt tension. There should be 1/2 inch slack. See maintenance section if adjustment is necessary. Refer to figure 4.

▲ WARNING *Always make sure main power is off before touching belts or other moving parts of compressor.*



3. Make sure no tools are attached to air hose before starting engine.
4. Pull pressure relief knob to up position to release head pressure and for easy starting. Failure to open pressure relief valve will cause electric start motor to overheat. See figure 5.
5. Turn on gas line valve. (Not supplied on 18 & 24 Hp models because fuel tank is not mounted.)
6. For cold engine start, move choke lever to full choke position. For engines that are already warm, place lever in half choke or run position.

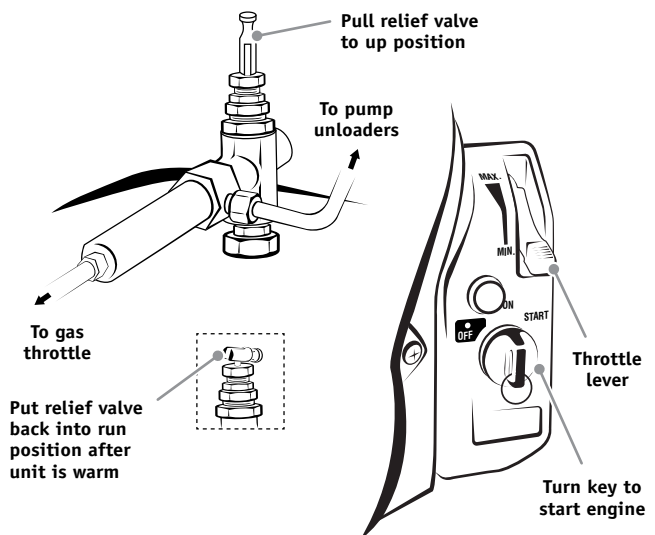

Figure 5: Starting Procedure

7. Start engine by turning key or with pull start cord.

NOTICE

If ignition fails to start engine after 5 seconds, release key and wait 10 seconds before trying again. Continuously trying to crank starter can overheat and damage starter motor.

8. After engine starts, move choke lever to run position.
9. Allow engine to warm up then turn pressure relief knob to run position.
10. Keep ball valve open for approximately 20-30 minutes before initial use to allow for pump break-in period. Be sure to close ball valve for unit to build pressure for proper operation.

Maintenance

Safety Steps

▲ WARNING



Disconnect, tag and lock out power source then release all pressure from the system before attempting to install, service, relocate or perform ANY maintenance.

1. Make sure repairs are done in a clean, dry, well lighted and ventilated area.
2. Disconnect engine spark plug wire before performing any maintenance or repairs.
3. When cleaning, use air pressure less than 30 psig (2.1bar). NEVER use flammable solvents for cleaning purposes. Also use effective chip guarding and personal protective equipment per OSHA standard 29 CFR 1910.242 (b).
4. Relieve all internal pressure prior to opening any line, fitting, hose, valve, drain plug, connection or other component, such as filters and line oilers, and before refilling optional air line anti-icer systems with antifreeze compound.

▲ CAUTION



Compressor components can become hot during operation. Avoid bodily contact with hot liquids, hot surfaces and sharp edges and corners.

Belt Adjustment

▲ WARNING



Be sure to relieve all system pressure then lock out power and tag compressor to prevent unexpected movement of the unit.

Inspect belt tension after first 30 hours of operation then every 30 days.

1. Proper belt tension is determined by pressing on belt midway between motor pulley and flywheel. There should be approximately 1/2 inch of deflection. See figure 4, pg. 7.
2. Loosen motor (4) mounting bolts, found underneath motor mount bracket. Slide motor in bracket slots as needed for proper tension. See figure 6. **Be sure motor shaft and pulley are aligned properly with pump before tightening motor bolts and restarting unit.**
3. Always replace all belts with the same brand, at the same time. Make sure belts are uni-matched. Do not replace belts independently.
4. Do not splash lubricating oil on belts or pulleys when adjusting or replacing belts.

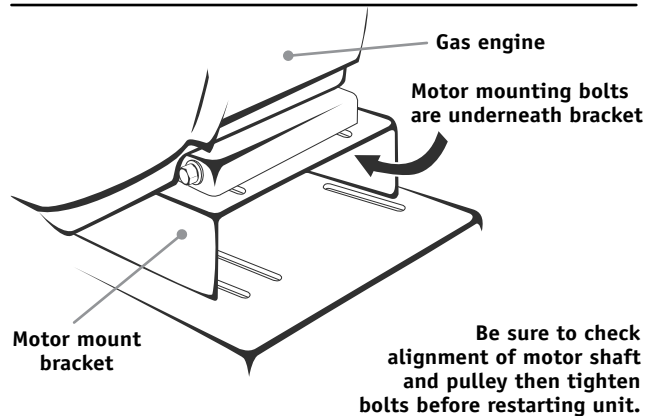

Figure 6: Move motor for belt adjustment

Changing Oil

All units are shipped with break-in oil. Change oil within first 30 hours or 10 days of operation, whichever comes first. **DO NOT use automotive type oil.**

NOTICE

Use only Airbase Industries oil (PN: APOL03000G1). Use of any other product will cause product damage and void the warranty.

Change oil every 90 days or if oil becomes milky. High humidity and excessive temperature changes can cause moisture to form in the pump. This moisture will cause oil to break down and become milky. Be sure to check oil regularly for proper lubrication. Make sure to dispose of used parts such as oil and filters in accordance with all applicable regulations.

Safety Valve

⚠ DANGER



NEVER attempt to regulate or tamper with safety valve. Valve is sealed and certified by ASME code and is designed to relieve system pressure when necessary.

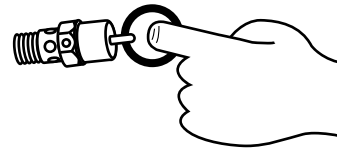

Pull ring on safety valve before each use.

Figure 7: Safety Valve

Check proper operation of safety valve before each use. Refer to figure 7. If valve does not open manually, **replace immediately**. Discharge pressure is generally set at 175 PSI (12.1 bar). **DO NOT** attempt to open valve while machine is under pressure.

Tank

Drain daily.

Maintenance Schedule

Daily	<input type="checkbox"/> Check oil level <input type="checkbox"/> Check for unusual operation. Correct before damage occurs.	<input type="checkbox"/> Check safety valve <input type="checkbox"/> Drain tank and traps
Weekly	<input type="checkbox"/> Clean air filter <input type="checkbox"/> Change oil (<i>after first 30 hours</i>)	<input type="checkbox"/> General unit cleaning <input type="checkbox"/> Check for unusual operation. Correct before damage occurs.
Monthly	<input type="checkbox"/> Check and tighten all bolts as required <input type="checkbox"/> Check all connections for air leaks <input type="checkbox"/> Check belts for proper tension, wear, and alignment	<input type="checkbox"/> Inspect oil for contamination. Change if necessary. <input type="checkbox"/> Check all unloading lines for leaks. <i>Air leaks in unloader lines will cause unloaders and pilot valve to chatter and could cause short cycling of motor.</i>
Every 3 months	<input type="checkbox"/> Change oil	<input type="checkbox"/> Inspect valve assemblies

Notes

Troubleshooting Chart

Problem	Possible Causes	Resolutions
Engine does not start	Low/No fuel	Fill gas tank
	Clogged/leaking fuel line	Check fuel line, clean or replace as needed
	Water in fuel	Drain fuel tank then refill with fresh fuel
	Unloader valve(s) stuck	Check for proper operation, repair or replace valves if necessary.
	Spark plug not operating	Change spark plug
	Low oil shutdown feature on gas engine is activated	Add oil to engine
	Compressor pump has run dry	Add lubricating oil then check for proper operation. Replace pump if necessary.
		<div style="border: 1px solid black; display: inline-block; padding: 2px 5px; margin-right: 5px;">NOTICE</div> <i>Use only Airbase Industries oil (PN: AP0L03000G1). Use of any other product will cause product damage and void the warranty.</i>
Low air pressure	Pilot valve not set properly	Call EMAX Service or local dealer to adjust valve
	Head unloader sticking	Lubricate valve with industrial grade grease
	Intake or exhaust valves not functioning properly	Repair or replace valves as needed
	Air leak(s) in system	Use soapy water to locate leaks, replace or tighten threaded parts
	Engine running too slow	Adjust throttle linkage
	Clogged air filter	Replace air filter
	Application exceeds rated air output of compressor	Check CFM requirements, change tool or use compressor with higher air output
Excessive vibration	Improper compressor mounting	Ensure tank is located on properly sized rubber padding
	Loose belts or other system component	Adjust belt tension, tighten mounting and/or other bolts as necessary
	Engine running too fast	Adjust throttle linkage

Warranty Statement

Emax, INC. (also known as EATON-MAX, Inc. and each of its subsidiaries) makes the following Warranties:

1. THAT EACH **ROTARY SCREW AIR COMPRESSOR PUMP** TO BE FREE FROM DEFECTS IN MATERIAL, WORKMANSHIP, AND PARTS FOR 10 YEARS ON THE ROTARY SCREW AIR COMPRESSOR PUMP FROM THE DATE OF PURCHASE. Emax (and each of its subsidiaries) is not responsible for downtime during warranty service. If downtime is necessary, it is the Purchaser's discretion and obligation (at Purchaser's expense) to have a redundant UNIT. This warranty applies to rotary screw rotors and bearings. The electric motor carries a five year warranty and a 2 year warranty on the rest of the compressor unit. The screw compressor MUST have Emax, Inc. Lubricant Synthetic exclusively, the same which must be purchased from Emax, Inc. (Mixing different brands of oil will void this warranty and cause the rotors to varnish). All air filters, oil filters, and oil separator filters must be purchased from Emax, Inc. and the screw compressor must have Emax, Inc. Synthetic Rotary Screw oil, purchased exclusively from Emax, or an Emax dealer, for this warranty to apply.

Annual participation in all oil programs are required by original purchaser of the unit outlined by the following:

- a) Purchase an oil sample kit for oil analysis by Emax or Emax Dealer.
- b) Oil sample kit contains 20 oil sample containers. One (1) oil sample is to be sent for analysis by an Emax oil analysis laboratory every six (6) months so oil can be tested twice yearly.
- c) Oil samples are obtained by draining ___ ozs. of oil into container then mailing sample container to laboratory address provided in oil sample kit.
- d) The laboratory will perform an oil analysis then email a report to email address required when oil sample is provided.
- e) Provide annual proof of purchase for oil/filter service kit.
- f) Maintain proper oil level in unit at all times. If the unit runs out of oil, this warranty is void.

Failure of original purchaser to comply with any of the above conditions pertaining to oil analysis with void the complete unit warranty.

A full detailed maintenance schedule must be sent to Emax, Inc. once a year with the total service completed quarterly, outlining each air filter, oil filter and oil change with the total hours on the unit after each maintenance was performed.

Failure to fully comply with this warranty and fully comply with the manual herein will void this warranty.

Exclusions to this warranty also include all normal wear and tear items, including, but not limited to the bearings, rotors, valves, belts, shaft seal and load/unload solenoids.

2. THAT EACH **BARE COMPRESSOR PUMP UNIT** TO BE FREE FROM DEFECTS IN MATERIAL, WORKMANSHIP, AND PARTS FOR 5 YEARS FOR THE UNIT FROM THE DATE OF PURCHASE. Emax (and each of its subsidiaries) is not responsible for downtime during warranty service. If downtime is necessary, it is the Purchaser's discretion and obligation (at Purchaser's expense) to have a redundant UNIT. Warranty repairs shall not include freight costs. Purchaser is responsible for returning unit to Emax, Inc. This pump must have Emax Inc, lubricant Synthetic exclusively, the same which must be purchased from Emax Inc. (Mixing different brands of oils will void the pump warranty). A service kit must be purchased from Emax or an Emax dealer for this warranty to apply. Service kits contain an air filter and synthetic oil that must be changed annually. Annual proof of purchase of all oil programs must be maintained by the original purchaser of the compressor pump. If the unit runs out of oil, this warranty is void. Failure to fully comply with this warranty and fully comply with the manual herein will void this warranty.

Exclusions include: service such as OIL CHANGES, FILTER REPLACEMENTS, GASKET TIGHTENING TO CORRECT OIL SEEPAGE or DRIVE BELT TIGHTENING and VALVE CLEANING and are not covered under warranty.

Warranty shall be void under the following conditions: Failure to routinely change oil and to maintain a clean filter, or **exceeding 70% duty cycle resulting in overheating and excessive wear and tear**, or exposing electrical components to rain or water, or installing the unit in a hostile environment such as acid vapors or any caustic or abrasive matter that may be ingested into the pump, or installing the unit in an enclosed area where lack of cooling ventilation is present, such as in boiler or equipment rooms where the ambient air exceeds 100°F.

3. THAT EACH **COMPRESSOR UNIT** TO BE FREE FROM DEFECTS IN MATERIAL, WORKMANSHIP, AND PARTS FOR 5 YEARS FOR THE COMPRESSOR PUMP AND 2 YEARS ON THE REMAINDER OF THE UNIT FROM THE DATE OF PURCHASE. The UNIT also carries a 1-year labor warranty. Emax (and each of its subsidiaries) is not responsible for downtime during warranty service. If downtime is necessary, it is the Purchaser's discretion and obligation (at Purchaser's expense) to have a redundant compressor. Warranty repairs shall not include freight costs. Purchaser is responsible for returning unit to Emax, Inc. This pump MUST have Emax Inc. Lubricant Synthetic exclusively, the same which must be purchased from Emax, Inc. (Mixing different brands of oil will void this warranty). A service kit must be purchased from Emax or an Emax dealer for this warranty to apply. Service kits contain an air filter and synthetic oil that must be changed annually. Annual proof of purchase of all oil programs must be maintained by the original purchaser of the compressor unit. If the unit runs out of oil, this warranty is void. Failure to fully comply with this warranty and fully comply with the manual herein will void this warranty.

Exclusions include: service such as OIL CHANGES, FILTER REPLACEMENTS, GASKET TIGHTENING TO CORRECT OIL SEEPAGE or DRIVE BELT TIGHTENING and VALVE CLEANING and are not covered under warranty.

Warranty shall be void under the following conditions: Failure to routinely change oil and to maintain a clean filter, or **exceeding 70% duty cycle resulting in overheating and excessive wear and tear**, or exposing electrical components to rain or water, or installing the unit in a hostile environment such as acid vapors or any caustic or abrasive matter that may be ingested into the pump, or installing the unit in an enclosed area where lack of cooling ventilation is present, such as in boiler or equipment rooms where the ambient air exceeds 100°F.

4. THAT EACH **DRYER UNIT** TO BE FREE FROM DEFECTS IN MATERIAL, WORKMANSHIP, AND PARTS FOR 5 YEARS on the HEAT EXCHANGER AND 2 YEARS ON THE DRYER UNIT FROM THE DATE OF PURCHASE. Emax (and each of its subsidiaries) is not responsible for downtime during warranty service. If downtime is necessary, it is the Purchaser's discretion and obligation (at Purchaser's expense) to have a redundant DRYER UNIT. Warranty repairs shall not include freight costs. Purchaser is responsible for returning unit to Emax, Inc. Each **DRYER UNIT** must have a coalescing filter attached to the intake of the dryer to remove any oil or dirt before air enters the dryer. Failure to install coalescing filter will void the warranty.

5. GENERAL PROVISIONS: Emax (and each of its subsidiaries) is not responsible for downtime during warranty service. If downtime is necessary, it is the Purchaser's discretion and obligation (at Purchaser's expense) to have a redundant compressor. Warranty repairs shall not include freight costs. If necessary, the Purchaser is responsible for returning unit and/or applicable part(s) to Emax, Inc.

Exclusions include: service such as OIL CHANGES, FILTER REPLACEMENTS, GASKET TIGHTENING TO CORRECT OIL SEEPAGE or DRIVE BELT TIGHTENING and VALVE CLEANING and are not covered under warranty.

Further Exclusions include failure to fully and completely follow the guidelines set forth in the manual. Of specific note is where a product is used where granite and/or concrete work is performed or conditions are dusty and the product is required to be housed in a separate room from the adverse conditions where the product has access to fresh air intake.

Parts used for warranty purposes must be supplied by Emax, Inc. Warranty work will be performed by an approved Emax, Inc. Technician. If any maintenance (other than routine maintenance) is performed by a non-approved Emax, Inc. Technician, written pre-approval must be obtained from Emax, Inc. to prevent voiding this Warranty. Failure to fully comply with this warranty and fully comply with the manual herein will void this warranty.

All warranties are nontransferable.

The Oil Purchase Program is effective as of January 1, 2011.