

The power behind competitiveness

Delta UPS - Amplon Family

E Series, Single Phase
1/2/3 kVA

User Manual

www.deltapowersolutions.com



Save This Manual

This manual contains important instructions and warnings that you should follow during the installation, operation, storage and maintenance of this product. Failure to heed these instructions and warnings will void the warranty.

Copyright © 2011 by Delta Electronics Inc. All Rights Reserved. All rights of this User Manual ("Manual"), including but not limited to the contents, information, and figures are solely owned and reserved by Delta Electronics Inc. ("Delta"). The Manual can only be applied to the operation or the use of this product. Any disposition, duplication, dissemination, reproduction, modification, translation, extraction, or usage of this Manual in whole or in part is prohibited without the prior written permission of Delta. Given that Delta will continuously improve and develop the product, changes may be made to the information in this Manual at any time without obligation to notify any person of such revision or changes. Delta will make all possible efforts to secure the accuracy and the integrity of this Manual. Delta disclaims any kinds or forms of warranty, guarantee, or undertaking, either expressly or implicitly, including but not limited to the completeness, faultlessness, accuracy, non-infringement, merchantability or fitness for a particular purpose of the Manual.

Table of Contents

IMPORTANT SAFETY INSTRUCTIONS	1
Safety Instructions	1
Annotation and Symbol	2
CHAPTER 1 INTRODUCTION	3
1-1 Initial Inspection	3
1-2 Placement	3
1-3 About UPS Operation	4
1-4 Features	5
CHAPTER 2 OPERATION	6
2-1 Front Panel	6
2-2 Operation Panel	6
2-3 Rear Panel	8
CHAPTER 3 INSTALLATION	9
3-1 Installation	9
CHAPTER 4 OPERATION	12
4-1 Cold Start When the Utility is Not Present	12
4-2 Start Up the UPS	12
4-3 Shut Down the UPS	12
4-4 UPS Self Test	13
4-5 Silence Function	13
4-6 Charger Current Setting	13
4-7 Abnormal Condition	14
4-8 UPS Internal Fault	16
4-9 Power Derating	16
CHAPTER 5 MAINTENANCE	17
CHAPTER 6 TROUBLESHOOTING	18
CHAPTER 7 COMMUNICATION INTERFACE	19
7-1 RS232	19
CHAPTER 8 SELECT THE INSTALLATION OF THE FITTINGS	20
TECHNICAL SPECIFICATIONS	22

IMPORTANT SAFETY INSTRUCTIONS

This manual contains important instructions that should be followed during installation and maintenance of the UPS and batteries. Before installing and starting up the UPS, carefully read this manual and preserve this manual for future reference.

Safety Instructions

1. The UPS contains voltages which are potentially hazardous. All repairs should be performed by qualified service personnel.
2. To reduce the risk of electric shock, install this UPS in a temperature and humidity controlled indoor area, free of conductive contaminants. The ambient temperature must not exceed 40°C (104°F).
3. There should be an isolated switch (breaker) at the side of UPS output, which may be supplied by the user.
4. The UPS provides the function of output short protection, but the over-current protection of AC output loop should be given by the user.
5. Disconnect the supply power prior to connecting or disconnecting the battery cabinet.
6. Do not touch the battery terminal. The voltage may be present that is potentially dangerous.
7. Inspect the packing. If there is any damage, contact your dealer.
8. Do not dismantle the UPS system.
9. Do not use extended cables.
10. Do not operate the UPS in extremely wet environment or around the water.
11. Do not allow water or any foreign object to enter the UPS or put any objects containing liquid on or near the UPS.
12. Install the UPS in a well ventilated area away from gas. Do not block the ventilation holes.
13. Do not connect the rectified load on the half bridge to the output.
14. Do not operate the UPS if there is any liquid leakage or white root pulp.
15. The battery containing dangerous metals and chemicals must be processed according to local environmental protection laws and regulations.
16. Use the provided power cord that meets NEC standards, and make sure the output receptacles meet the NEC standards as well.
17. The voltage may be present even if the UPS with connected battery cabinet is not connected to the mains.
18. Do not move the battery cabinet while connecting to the UPS.
19. Do not connect or disconnect the battery cabinet when the UPS is in battery mode.

Warning!

This is a Class A UPS product. In a domestic environment, this product may cause radio interference in which case the user may be required to take adequate measures.

Annotation and Symbol

The following two signs shown in the manual indicate important instructions to be followed.



Read before Operation



Maybe Dangerous/Follow Instructions

	Protective grounding terminal: A terminal which must be connected to earth ground prior to making any other connection to the equipment.
	This symbol indicates the word "phase".
	This symbol indicates the principal on/off switch is in the "ON" position.
	This symbol indicates the principal on/off switch is in the "STAND-BY" position.

CHAPTER 1 INTRODUCTION

1-1 Initial Inspection



- Read this user manual before installing the UPS.
- Before unpacking the UPS, check the packing box. If there is any visible damage, contact your dealer at once.
 - This unit is to operate by any individuals with previous training.
 - This unit should be installed by qualified service personnel.

The UPS package contains the following items. Please check if any items are missing. If there is any damage or anything missing, please immediately contact the dealer from whom you purchased the unit.

No.	Item	Quantity
1	UPS	1 pc
2	User Manual	1 pc
3	RS232 Cable	1 pc
4	Battery Cable	1 set
5	Power Cord	1 pc
6	UPS Test Report	1 pc
7	Caution Letter	1 pc
8	Software CD: UPSentry Smart 2000	1 pc
9	Series Number Label	3 pcs

1-2 Placement



- Do not expose the UPS to direct sunlight or other heat sources. Position the UPS should be facing away from direct sunlight glare.
- Choose a well-ventilated area to position your UPS to allow adequate dissipation of heat.
- Ensure the UPS surrounding area is clean and free from moisture.
- Do not put heavy objects on the cable or power cord.

1-3 About UPS Operation

The main topology of the UPS consists of bypass path, AC-DC converter, DC-AC inverter, battery charger, DC-DC converter, control circuit and detection circuit. Moreover, the intelligent power management software is also optional. The function and efficiency are superior to the traditional UPS.

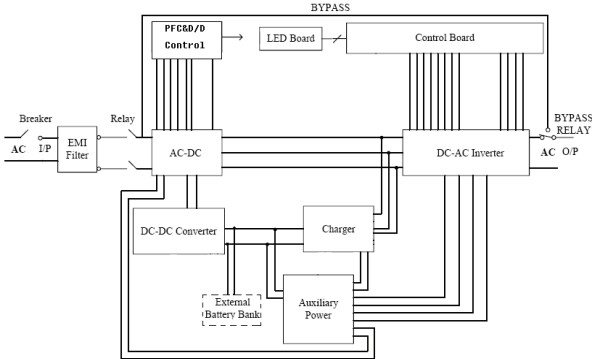

Fig. 1-1 Hardware Block Diagram of the UPS

When the utility power is applied to the UPS, it was divided into two ways after going through the breaker and EMI filter. One way is connected to AC-DC converter converting the utility AC power into a DC voltage that is called DC-BUS voltage. Then, it is divided into two paths. One path goes to charger which converts the DC-BUS voltage into a proper DC voltage to charge the UPS battery. The other path goes into DC-AC half bridge inverter. The other way works as a bypass path. The bypass relay near the output will select either the bypass path or inverter output. In general, the UPS will internally do the self-diagnosis. If there is no problem, the bypass relay will select the inverter output. This is called “**ON-LINE Mode**”.

In case the utility power fails, the AC-DC converter and charger will shut down. The DC-DC converter works and converts the battery voltage into DC-BUS voltage. The DC-AC inverter converts the DC-BUS voltage into AC voltage. This is called “**ON-BATTERY Mode**”.

The auxiliary power circuit supplies the designated power to all the control circuits. Since the DC-AC inverter is always working, the DC-DC converter can rapidly operate and replace the AC-DC converter if the utility power fails. Furthermore, the bypass relay continuously keeps in the position of inverter output to supply the regulated power for the load. There is no power failure in loading equipment.

1-4 Features

The UPS, which is available in 1KVA, 2KVA and 3KVA, is an advanced on-line UPS providing reliable and consistent sine wave power quality to vital equipment. It supports personal computers, networks, servers, telecommunication equipment and a variety of other facilities. With its outstanding protection features, the unit keeps your applications safe and running smoothly at all times.

PFC (Power Factor Correction)

With this function, the influence on the power grid can be greatly reduced. The investment in the capacity of circuit breakers can be lowered as well, especially it will be highly regarded as an important feature in critical load applications.

Complete Protection

On-line double conversion design, pure sine wave output and zero transfer time provide the best protection. With a built-in surge, spike and line noise protection, the UPS prevents destructive hardware damages and extends lifetime of system. The EMI/RFI filtering design prevents electrical noise from affecting computer operation and data files.

Intelligent Design

Integrated with a microprocessor, the UPS is able to perform intelligent functions. The UPS triggers over-voltage protection function and transfers to "On- Battery Mode" even when the utility voltage exceeds 280V for 230V Series. In addition, the UPS can accept large voltage variation of 80V to 280V. Wide input voltage range means less usage frequency of battery power and longer battery life-span. Besides, programmable outlet design, which is suitable for power management, is also included in this unit.

User-Friendly Interface

The UPS provides a variety of functions to meet users' needs. Users can instantly understand the status of the UPS via informative LED instruction. Audible alarms, bar meters and status indicators (such as battery replacement indication, UPS fault, line condition, overload and so on) are simple and easy for user to understand.

Network Management

The built-in communication interface port supporting RS232 protocols enhances the reliability and manageability of the UPS over all major operating systems, including Windows 95/98, Windows NT, Netware, Unix and others.

CHAPTER 2 OPERATION

2-1 Front Panel

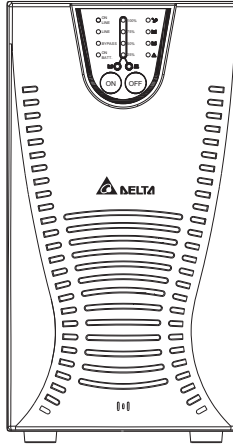

Fig 2-1 Front Panel for 1KVA, 2KVA and 3KVA

2-2 Operation Panel

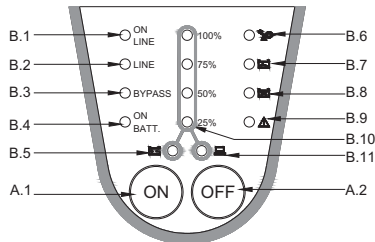



Fig 2-2 Operation Panel

A. Button

- 1  : In **“ON-LINE Mode”**, when the battery capacity is larger than 95%, press the ON button to start up the UPS. In backup mode, this button can silence the buzzer.
- 2  : Press the OFF button to shut down the UPS.

B. LED Display

- 1 **ON Line:** The LED indicates the UPS is operating in **“ON-LINE Mode”**.
- 2 **Line:** The LED indicates the condition of UPS input line. If the input voltage is too low, too high or out of frequency, this LED will flash. When the line is blackout, this LED will light off.
- 3 **Bypass:** The LED indicates the UPS is in **“BYPASS Mode”**.
- 4 **ON Battery:** The LED indicates the UPS is operating in **“ON-BATTERY Mode”** (backup mode).



- 5 **Battery:** When the LED lights up, “Level LEDs” will show the current battery capacity.



- 6 **Overload:** The LED indicates the load level of UPS exceeds the rating. After a limited period of time, the UPS will transfer to **“BYPASS Mode”** and the LED will still light up to alarm the user.



- 7 **Battery low:** The LED indicates the battery is in low voltage condition.



- 8 **Battery replace:** The LED indicates batteries are weak and it is suggested that the user should replace batteries.



- 9 **Fault:** The LED indicates that the UPS is faulty. The LED Flash indicates that the UPS is overheating.

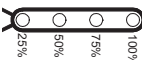

- 10 **Level LEDs:** The four LEDs indicate battery capacity in **“ON-BATTERY Mode”** or UPS load percentage in **“ON-LINE Mode”**.



- 11 **Load:** “Level LEDs” shows load level of UPS when the LED lights up.

2-3 Rear Panel

The rear panel is described as below. (Refer to Fig. 2-3.)

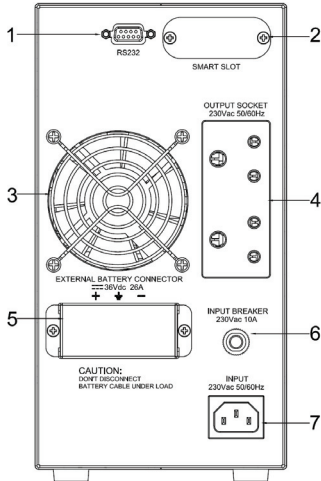

Fig. 2-3.1 (1KVA)

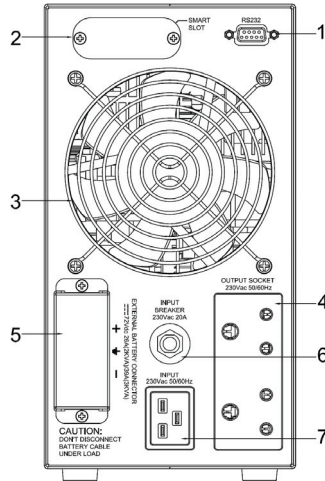

Fig. 2-3.2 (2KVA / 3KVA)

1. **RS232:** The communication port is used for communication between PC and UPS. For more detailed information, refer to Chapter 7.
2. **SMART SLOT (for Mini SNMP / Relay / USB Card, TVSS Card):**
 - a) **TVSS Card:** Protects your hardware from surge, spikes and line noise travelling along communication lines.
 - b) **SNMP:** For network management.
 - c) **RELAY:** This is used to provide 4 relay output joints to monitor status of UPS and relay input joint to control UPS off test battery.
 - d) **USB:** For communication between PC and UPS via USB cable.
3. **Fan:** For cooling purpose.
4. **OUTPUT SOCKET:** The UPS supplies the AC power to the load via receptacles.
5. **External Battery Connector:** Connects external battery cabinets to extend backup time.
6. **INPUT BREAKER:** Prevents the UPS damages from high input current.
7. **INPUT SOCKET:** AC input utility power supplies to the UPS via socket.

CHAPTER 3 INSTALLATION

3-1 Installation

Note:

- AC output needs a disconnect device (such as a breaker) which has to be provided by others.
- The wire length of output power cord connected to the output receptacle or pressure terminal should be less than 10 meters.
- The over current protection and short circuit protection for the AC output are provided by internal circuits of UPS.
- For details on battery voltage, ambient temperature and other specifications of the UPS, refer to Chapter 8 in this manual.

1. Connecting to Utility Power (Refer to Fig. 3-3)

- Connect the power cord with BS546 plug to the BS546 connector on the UPS.
- Plug the other end of the power cord into a two-pole, three-wire, grounding receptacle only. Avoid using extension cords and adapter plugs.
- When the utility power is applied to the UPS, the fan (in rear panel) will run and all LED indicators will light for about 2-3 seconds. Meanwhile, the CPU inside the UPS will determine the initial parameters. Users can also check if all the LED indicators are normal. The UPS is set in "STANDBY Mode" initially. After you hear a 'beep' sound, the load LED lights on and the line LED indicator shows the AC utility status. See Fig. 3-1.

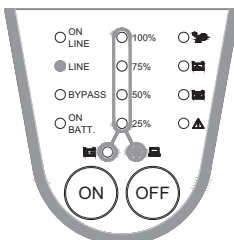

Fig. 3-1 STANDBY Mode

2. Charging the Battery

- The battery charger of the UPS automatically charges the battery whenever the power cord of UPS is connected to an acceptable utility power.

3. Connecting the Battery Pack

- Utilize the battery connection cable packed with the battery pack.
- Connect one end of the cable to the external battery connector of UPS, and the other end to the one of the battery pack.
- After connecting the battery pack, be sure to re-cover battery cover on terminal for UPS and battery pack as well.
- Warning: For safety reasons, the manufacturer suggests that ONE UPS SHOULD BE EQUIPPED WITH AT MOST FIFTEEN EXTERNAL BATTERY PACKS.
- The battery pack should be installed by qualified service personnel.

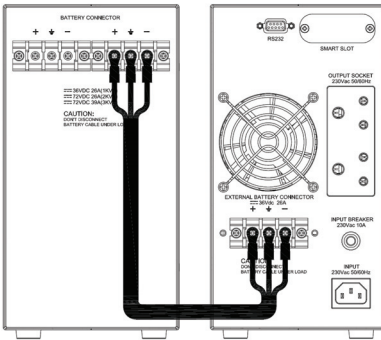

Fig. 3-2.1 (1KVA)

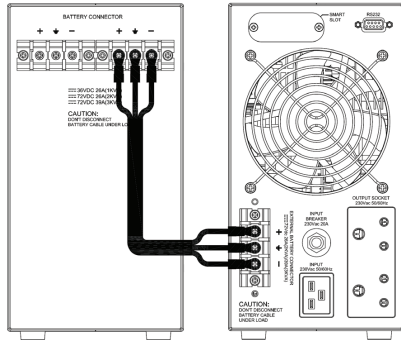

Fig. 3-2.2 (2KVA / 3KVA)

Fig. 3-2 UPS Connected to External Battery Pack

4. Connecting the Load

- Calculate the power consumption of your load to ensure that the overload condition will not happen.
- Plug the power cord of the equipment into the output receptacles on the rear panel of the UPS.
- Turn on the equipment connected to the UPS.



- Caution: Do not connect a laser printer to the UPS.
- Caution: Do not connect the UPS to the generator.

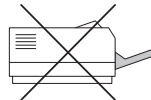

5. Connecting the RS232

- Connect the interface signal cable between the RS232 port on the rear panel of UPS and COM1 or COM2 of computer if necessary.
- The D-sub 9 connector can work as a RS232 communication port depending on the cable type and software used. For more information, refer to Chapter 7.

UPS Connection for 1KVA (See Fig.3-3.1):

- (1) Connects to RS232 cable.
- (2) Provides power to PC.
- (3) Connects to utility power.

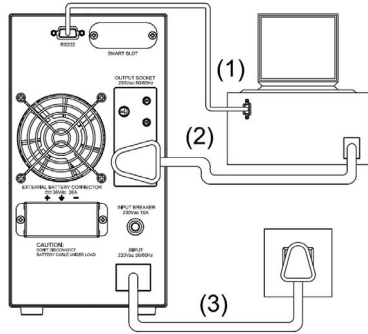

Fig. 3-3.1

UPS Connection for 2KVA or 3KVA (See Fig.3-3. 2):

- (1) Connects to RS232 cable.
- (2) Provides power to PC.
- (3) Connects to utility power.

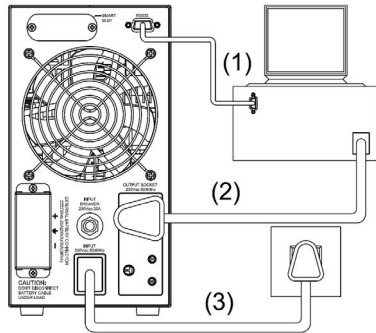

Fig. 3-3.2

CHAPTER 4 OPERATION

4-1 Cold Start When the Utility is Not Present

Even if there is no utility power but battery pack, you can still start up the UPS. Press and hold the ON button for 2~4 seconds, then you will hear a “beep” sound that means the UPS will start up. The battery LED and on-battery LED will light on and the UPS will operate in “ON-BATTERY Mode”. See Fig. 4-1.

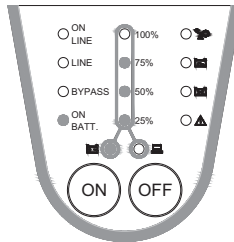

Fig. 4-1 On-Battery Mode

4-2 Start Up the UPS

To start up the UPS, press and hold the ON button for few seconds until you hear a “beep” sound. The bypass LED will extinguish shortly after lighting on. When the on-line LED lights on, the UPS is operating in “ON-LINE Mode”. See Fig. 4-2.

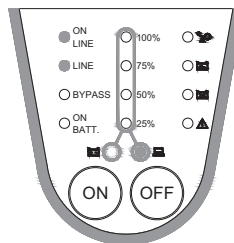

Fig. 4-2 On-Line Mode

4-3 Shut Down the UPS

To shut down the UPS, press the OFF button until you hear a “beep” sound. After a few seconds, the UPS will be powered off. Even though the OFF button has been pressed, the UPS will keep charging when the UPS operates in “STANDBY Mode”. To fully shut down the UPS, it is suggested that you unplug the power cord. See Fig. 3-1.

4-4 UPS Self Test

When the UPS is in "ON-LINE Mode" and battery capacity is larger than 95%, pressing the ON button will make the UPS transfer to "ON-BATTERY Mode" and automatically perform a self test for about 10 seconds (See Fig. 4-3.). The self-test function will check the condition of the battery. If the UPS passes the self-test, it will return to "ON- LINE Mode".

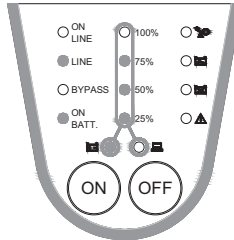

Fig. 4-3 UPS Self Test

4-5 Silence Function

When the UPS is running in "ON-BATTERY Mode", toggling the [On Test] button can turn "On" or "Off" the buzzer.

4-6 Charger Current Setting

- The UPS will be in "Charger current setting mode" after you hear the second "beep" sound. Just press and hold the ON button for 6-8 seconds.
- Refer to the status of charger current corresponding percentage of LED flashing:

Percentage of LED Flashing	Status of Charger Current
25%	0.7A
50%	1.4A
75%	3A
100%	4A
All LEDs flashing	The charger current has not been set.

- Press the ON button, then different LED indicators will flash with a circular sequence (25% LED-> 50% LED-> 75% LED-> 100% LED-> All LED-> 25% LED).
- Press the OFF button to confirm the charger current setting.

4-7 Abnormal Condition

If certain abnormal condition occurs, the UPS will send the following messages.

- ✓ **ON-BATTERY Mode:** When the UPS is in “ON-BATTERY Mode”, the on- battery LED will light on and the buzzer will beep for half seconds every 2 seconds. Then, the UPS will start supplying power to the load through batteries. See Fig. 4-4.

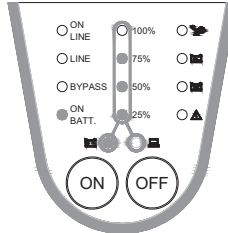

Fig. 4-4 On-Battery Mode

- ✓ **OVERLOAD:** If the load exceeds the UPS rating after a limited period, the overload LED will light on and buzzer will continuously beep to alarm users. Users should unplug some uncritical loads to release the overload condition. See Fig. 4-5.

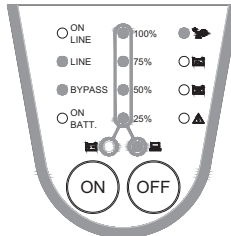

Fig. 4-5 Overload and UPS Transfer to Bypass

- ✓ **BATTERY REPLACEMENT:** This LED function is to alert users that the batteries should be replaced. When the microprocessor in the UPS detects a battery fault, the UPS alarm will beep for 0.1 seconds every 2.0 seconds. See Fig. 4-6.

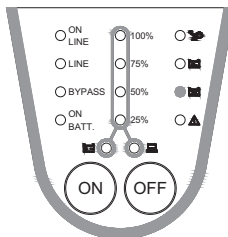

Fig. 4-6 Battery Replace

- ✓ **BATTERY LOW:** This function is to inform users the remaining power capacity of the batteries. When batteries reach a low level condition, the UPS alarm will beep for half seconds every 1.25 seconds until running out of battery capacity. See Fig. 4-7.

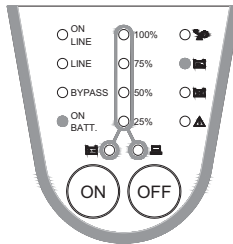

Fig. 4-7 Battery Low

- ✓ **SHORT CIRCUIT:** When the UPS output short circuit occurs in “ON-LINE Mode” or “ON-BATTERY Mode”, the UPS will turn off the inverter (without output voltage). As soon as the short circuit happens, the fault LED will light on and the UPS alarm will sound continuously. While removing short circuit, the UPS output will recover. If short circuit happens in “BYPASS Mode”, the UPS will protect itself by tripping the input breaker and shut down. See Fig. 4-8.

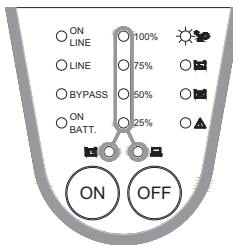

Fig. 4-8 Short Circuit

- ✓ If short circuit happens during AC soft-start process, the breaker will be tripped off. After solving the fault, be sure to press the off button until the fan stops before turning on the breaker.

4-8 UPS Internal Fault

If the following conditions occur, the UPS fails. At this time the UPS will transfer to "BYPASS Mode". The bypass LED and fault LED will light on and alarm continuously. If the utility is too low or too high, the UPS output will be disabled. For fault messages, refer to "Troubleshooting" (Chapter 6) of this manual.

- When the UPS inner component overheats, the UPS will protect itself by thermo switches. This status is called "O.T.P".
- When under (or over) voltage happens in the UPS output, this kind of fault will be detected by the microprocessor in the UPS and is called "U.V.P" ("O.V.P").
- When under (or over) bus voltage happens in the UPS, this kind of fault is called "Bus U.V.P" ("Bus O.V.P").

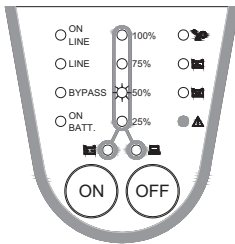

Fig. 4-9 Output U.V.P

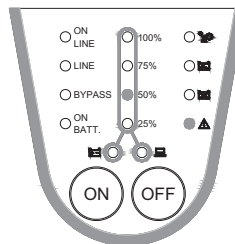

Fig. 4-10 Output O.V.P

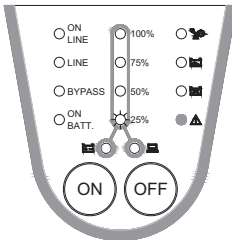

Fig. 4-11 DC BUS U.V.P

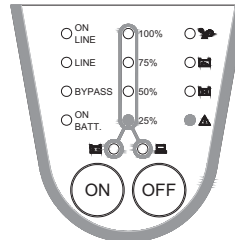

Fig. 4-12 DC BUS O.V.P

4-9 Power Derating

In the range of 80Vac to 176Vac, the UPS load capacity will decrease. This function provides a wider operating power voltage range.

CHAPTER 5 MAINTENANCE

- To replace batteries, contact your qualified service personnel.
- If the UPS has not been used for a period of time, the batteries will discharge slightly. It is recommended that you should charge the UPS once every 3 months.
- Use a vacuum cleaner to clean out all the dust that may rest on the opening of the fan.
- Unplug the UPS when it is not used for a long time.
- While cleaning the plastic case or front panel, only use a soft, dry cloth. If the case or front panel is very dirty, use a neutral, non-abrasive detergent. Do not use alcohol or ammonia based solutions.
- While moving your UPS, always handle it with care.
- Avoid spilling liquid on the UPS.
- The equipment should be repaired and installed by individuals with previous training.
- While installing this equipment, note that the leakage current of the UPS and its loads must not exceed 3.5mA in total for safety.

CHAPTER 6 TROUBLESHOOTING

Problem	Possible Cause	Solution
UPS is not turned on. (No alarm, No LED lights)	The ON button is not pressed.	Press the ON button to start up the UPS. (Refer to description of "Start Up the UPS" in Chapter 4.)
	Battery low shut down and utility is absent.	Waiting for line recovery.
	Input circuit breaker on rear panel tripped. (Button is tripped out)	1. Remove some loads connected to the UPS. 2. Reset the circuit breaker. (Press the ON button again.)
	UPS fault.	Contact your service personnel to call for qualified service personnel if the actions mentioned above still cannot solve the problem.
UPS does not provide expected back-up time.	Batteries pack is not fully charged.	Recharge the battery pack for at least 8 hours.
	The UPS is overloaded.	Remove some unnecessary loads.
	Weak batteries.	Batteries weak faster when often used or operating at higher temperature. If the battery is near the end of its life, contact your service personnel. Replace the battery even if the REPLACE BATTERY LED does not light.
	Charger fault or other reasons.	Contact your service personnel to call for service.
All LEDs light on.	Internal UPS fault.	1. Shut down the UPS. 2. Call for service.
"REPLACE BATTERY" LED lights on.	Weak batteries.	1. Recharge the batteries for at least 8 hours. 2. If problem still exists, contact your service personnel to replace the batteries.
PC-UPS communication does not work properly.	Incorrect transmission speed.	Re-test after using the other different transmission speed.
	Incorrect RS232 connection.	Refer to description of Communication Interface in Chapter 7 of this manual.
UPS operates on battery even though the line is in normal operating condition.	No incoming utility.	Check the input power connection.
	The rear panel input circuit breaker is tripped. (Button is out).	1. Reduce some loads connected to the UPS. 2. Reset the circuit breaker. (Press the ON button again.)
	Very high, low or distorted utility voltage.	Have a qualified electrician check the input voltage.
Site wiring fault LED (fault led flash).	Wiring error such as reversed hot/neutral.	Have a qualified electrician check the wiring.
UPS over temperature.	The exhaust fans and ventilation grills may be obstructed.	Choose a well-ventilated area to position your UPS allowing for adequate dissipation of heat.
	The environment temperature exceeds 40°C (104°F).	Position your UPS in a cooler area.
"FAULT"LED lights on, alarm beeps	UPS Failure	Contact your service engineer.
"OVERLOAD" LED lights on and buzzer beeps continuously.	Overloaded.	Remove some critical loads.

CHAPTER 7 COMMUNICATION INTERFACE

The UPS provides **RS232** protocols in one D-sub 9 connector. Using proper UPS management software and cable can manage the UPS over an IP network (LAN/intranet/internet). To download the UPS management software, please go to <http://59.125.232.140>.

The pin assignment of the D-sub 9 connector is defined as below.

PIN	ASSIGNMENT DESCRIPTION		PIN
	RS232		
1		GND	5
2	UPS TxD (typical RS232 level)		6
3	UPS RxD (typical RS232 level)	Reserved for PNP	7
4			8
			9

7-1 RS232

Pin2: PC receives line **RS232** data from UPS.

Pin3: PC transmits line **RS232** data to UPS.

Pin5: Signal ground.

Pin7: Reversed for plug and play function.

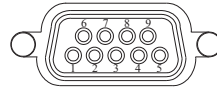

Fig. 7-1 Pin Assignment

The **RS232** communication port provides the following functions:

- 1) Charger status monitoring
- 2) Battery status and condition monitoring
- 3) Inverter status monitoring
- 4) Utility status monitoring
- 5) Power switch function- To turn on/off the utility via PC on schedule to save power.
- 6) Adjustable transfer voltage

The UPS data is provided at 2400 bps baud rate and made up of 8-bit, 1 stop-bit and no parity bit. All information is encoded in ASCII format.

HARDWARE:

- BAUD RATE-----2400 bps
- DATA LENGTH-----8 bits
- PARITY-----NONE
- STOP BIT-----1 bit

CABLING: Standard D-sub 9 cable (UPS side: Male, PC side: Female)

CHAPTER 8 SELECT THE INSTALLATION OF THE FITTINGS

8-1 Installation Procedures for Mini SNMP/Relay/USB Card in 1KVA MODEL

1. Remove the Smart slot cover without hole from rear panel.
2. Remove the left cover.
3. Take out the Mini SNMP / Relay / USB Card from packing box, then install the flat cable assembly on card.
4. Insert the Mini SNMP / Relay / USB Card with flat cable assembly in the hole, then tighten screws.
5. Insert the other connector of flat cable assembly in the connector of control board's CN7.
6. Install the left cover, then tighten screws.

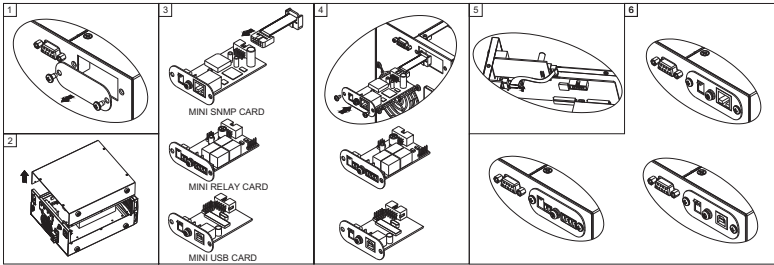

8-2 Installation Procedures for 1KVA MODEL TVSS Card

1. Remove the Smart slot cover without hole from rear panel.
2. Insert the TVSS card in the hole, then tighten screws.

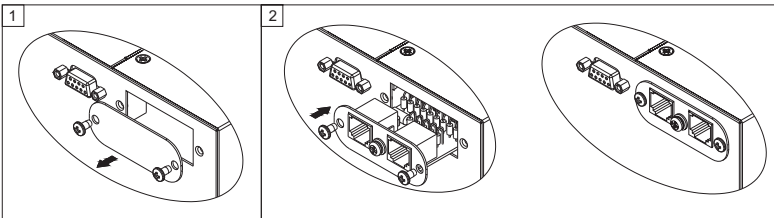

8-3 Installation Procedures for Mini SNMP/Relay/USB Card in 2/3KVA MODEL

1. Remove the Smart slot cover without hole from rear panel.
2. Remove the left cover.
3. Take out the Mini SNMP/Relay/USB card from packing box, then install the flat cable assembly on card.
4. Insert the Mini SNMP/Relay/USB card with flat cable assembly in the hole, then pull the other connector of flat cable assembly to insert it in the connector of control board's CN7.
5. Tighten screws for Mini Card.
6. Install the left cover, then tighten screws.

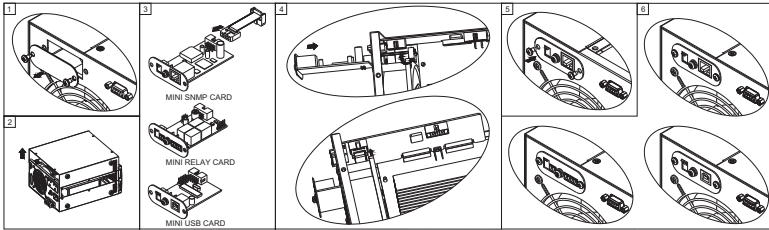

8-4 Installation Procedures for 2/3KVA MODEL TVSS Card

1. Remove the Smart slot cover without hole from rear panel.
2. Insert the TVSS card in the hole, then tighten screws.

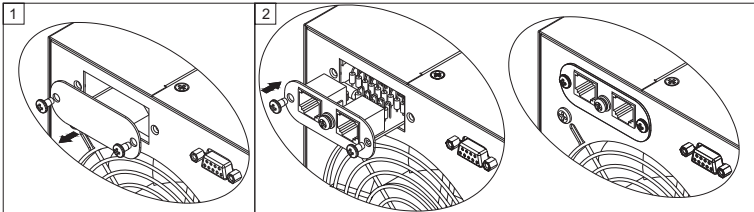

TECHNICAL SPECIFICATIONS

Model		1KVA	2KVA	3KVA
Capacity		1KVA/700W	2KVA/1400W	3KVA/2100W
Input	Rated Voltage	230V		
	Voltage Range	176V~280V(Full Load); 80V~176V(100% to 50% Load de-rating Linearly)		
	Frequency	50/60Hz (±5.0 Hz)		
	Power Factor	(0.97		
Output	Voltage	230V		
	Frequency	50/60Hz		
	Voltage Regulation	±2%		
	Frequency Accuracy	±0.05 Hz		
	Wave Form	Pure Sine Wave		
	Transient Response	±8% (10%~90% Linear Load)		
	THD	≤3%(Linear Load)		
	Overload Capacity	105%-125% for 3mins; 125%-150% for 30secs; >150% for 1sec		
	Crest Factor	3:1		
Efficiency (ON-LINE mode)	≥ 87% (Battery fully charged)			
Outlet	Receptacle	BS546×2 (10A)	BS546×2 (10A)	
Battery Pack	Battery Voltage	36 V	72V	72V
Transfer Time	Transfer Time	4 ms		
LED	LED Status	On-line, Bypass, On-battery, Overload, Battery Low, Fault, Battery Replace, Battery Level and Load Level.		
	Alarm	Buzzer		
Interface	DB9	RS232		
	SNMP Slot	Yes (Optional)		
Environment	Noise (At 1 Meter)	40dBA	54dBA	
	Operating Temperature	0~40°C		
	Humidity	0%~90% (Non-Condensing)		
Safety Approval	EMC	CISPR PUB 22 Class A		
	Lightning	IEEE 62.41 Category A		
Others	Battery Start (No AC)	Yes		
	Extendable Battery pack	Yes (Optional)		
	AC start (No Battery)	Yes		
Appearance	Dimension (W×D×H)	140 x 362 x 267/mm	5.5 x 14.3 x 10.5 / inch	
	Weight	5kg / 11 lb	7 kg / 15.4 lb	

⚠ All specifications are subject to change without prior notice.

Warranty

Seller warrants this product, if used in accordance with all applicable instructions, to be free from original defects in material and workmanship within the warranty period. If the product has any failure problem within the warranty period, Seller will repair or replace the product at its sole discretion according to the failure situation.

This warranty does not apply to normal wear or to damage resulting from improper installation, operation, usage, maintenance or irresistible force (i.e. war, fire, natural disaster, etc.), and this warranty also expressly excludes all incidental and consequential damages.

Maintenance service for a fee is provided for any damage out of the warranty period. If any maintenance is required, please directly contact the supplier or Seller.

WARNING : The individual user should take care to determine prior to use whether the environment and the load characteristic are suitable, adequate or safe for the installation and the usage of this product. The User Manual must be carefully followed. Seller makes no representation or warranty as to the suitability or fitness of this product for any specific application.

