

ORDERING REPLACEMENT PARTS

If you encounter any difficulties or problems with this product, contact the ICON Fitness Lifestyle Ltd. office, or write:

ICON Health & Fitness Ltd.
Unit 4
Revie Road Industrial Estate
Revie Road
Beeston
Leeds, LS118JG
UK

Tel: Country Code:

08457 089 009

Outside the UK: 0 (044) 113 387 7133
Fax: 0 (044) 113-387 7125

When ordering parts, please be prepared to give the following information:

- The MODEL NUMBER of the product (WEEVSY87210)
- The NAME of the product (WEIDER® 8515 weight system)
- The SERIAL NUMBER of the product (see the front cover of this manual)
- The KEY NUMBER and DESCRIPTION of the part(s) (see the PART LIST and EXPLODED DRAWING attached at the centre of this manual).

WEIDER is a registered trademark of ICON Health & Fitness, Inc.

WEIDER 8515

Model No. WEEVSY87210
Serial No. _____

Write the serial number in the space above for future reference.

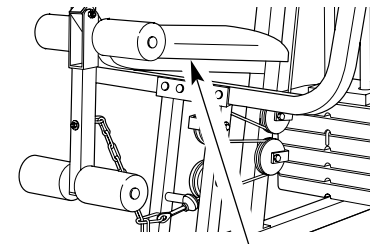

Serial Number Decal

QUESTIONS?

As a manufacturer, we are committed to providing complete customer satisfaction. If you have questions, or if there are missing or damaged parts, please call:

08457 089 009

Or write:
ICON Health & Fitness Ltd.
Unit 4
Revie Road Industrial Estate
Revie Road
Beeston
Leeds, LS11 8JG
UK
email: csuk@iconeurope.com

CAUTION

Read all precautions and instructions in this manual before using this equipment. Save this manual for future reference.

USER'S MANUAL

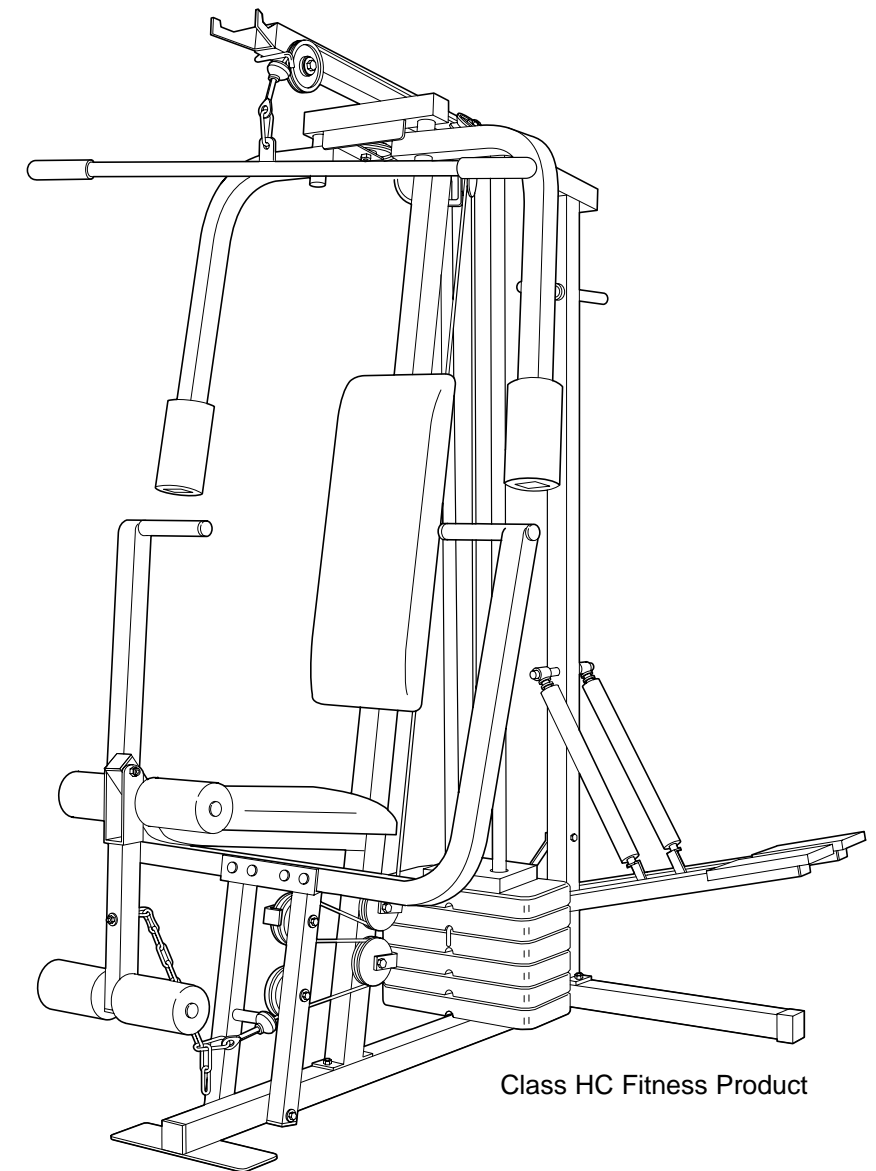

Class HC Fitness Product



Visit our website at

www.iconeurope.com

TABLE OF CONTENTS

IMPORTANT PRECAUTIONS3
BEFORE YOU BEGIN4
ASSEMBLY5
HOW TO USE THE WEIGHT SYSTEM17
TROUBLESHOOTING AND MAINTENANCE21
CABLE DIAGRAM22
ORDERING REPLACEMENT PARTSBack Cover

Note: A PART IDENTIFICATION CHART and a PART LIST/EXPLODED DRAWING are attached in the centre of this manual. Remove the PART IDENTIFICATION CHART and the PART LIST/EXPLODED DRAWING before beginning assembly.

NOTES

IMPORTANT PRECAUTIONS

⚠ WARNING: To reduce the risk of serious injury, read the following important precautions before using the weight system.

1. It is the responsibility of the owner to ensure that all users of the weight system are adequately informed of all precautions.
2. Read all instructions in this manual and in the accompanying literature before using the weight system.
3. Use the weight system only on a level surface. Cover the floor beneath the weight system to protect the floor or carpet.
4. Inspect and properly tighten all parts regularly. Replace any worn parts immediately.
5. Keep children under 12 and pets away from the weight system at all times.
6. Keep hands and feet away from moving parts.
7. Always wear athletic shoes for foot protection.
8. Never release the press arm, butterfly arms, leg lever, lat bar, or nylon strap while weights are raised. The weights will fall with great force.
9. Always disconnect the lat bar from the weight system when performing an exercise that does not require the lat bar.
10. Always stand on the foot plate when performing an exercise that could cause the weight system to tip.
11. Inspect all cables before each use. Make sure that the cables remain on the pulleys at all times. If the cables bind whilst you are exercising, stop immediately and make sure that the cables are on all of the pulleys. Replace all cables every two years.
12. The resistance cylinders become very hot during use. Allow the cylinders to cool before touching them.
13. If you feel pain or dizziness while exercising, stop immediately and begin cooling down.
14. Always attach the lock pin and lock to the weight guide when the weight system is not in use (see page 19).
15. The weight system is intended for home use only. Do not use the weight system in any commercial, rental, or institutional setting.

⚠ WARNING: Before beginning this or any exercise program, consult your physician. This is especially important for persons over the age of 35 or persons with pre-existing health problems. Read all instructions before using. ICON assumes no responsibility for personal injury or property damage sustained by or through the use of this product.

CABLE DIAGRAM

The cable diagram below shows the proper routing of the Short Cable (58) and the Long Cable (23). Use the diagram to be sure that the two cables and the cable traps have been assembled correctly. If the cables have not been correctly routed, the weight system will not function properly and damage may occur. The numbers show the correct route for each cable. The starting and ending points of each cable are labelled. **Be sure that the cable traps do not touch or bind the cables.**

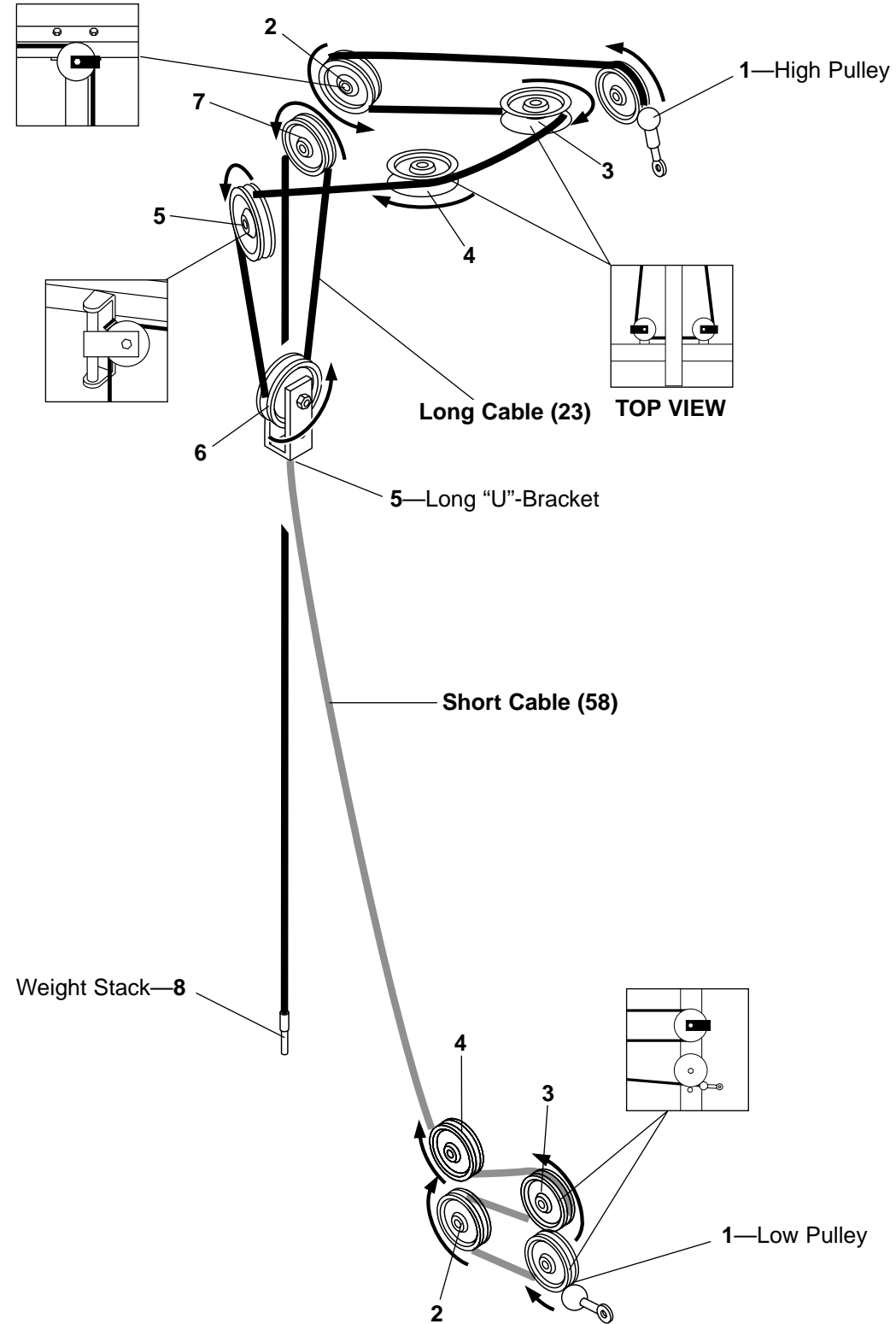

The decals shown below have been placed on the weight system in the locations shown. If decals are missing or illegible, please call our Customer Service Department to order free replacement decals (see the back cover of this manual). Apply the decals in the locations shown.

⚠ WARNING
This equipment is not to be used by more than one person at a time.

⚠ WARNUNG
Erlauben Sie niemals mehr als einer Person die Benutzung des Gerätes.

⚠ ATTENTION
Cet appareil ne doit être utilisé que par une personne à la fois.

⚠ ATTENZIONE
Non permettere a più di una persona alla volta di usare questo equipaggiamento.

⚠ PRECAUCIÓN
Este equipo no debe ser utilizado por más de una persona al mismo tiempo.

⚠ WARNING

- Misuse of this product may result in serious injury.
- Read user's manual and follow all warnings and operating instructions prior to use.
- Do not allow children on or around machine.
- Replace label if damaged, illegible, or removed.

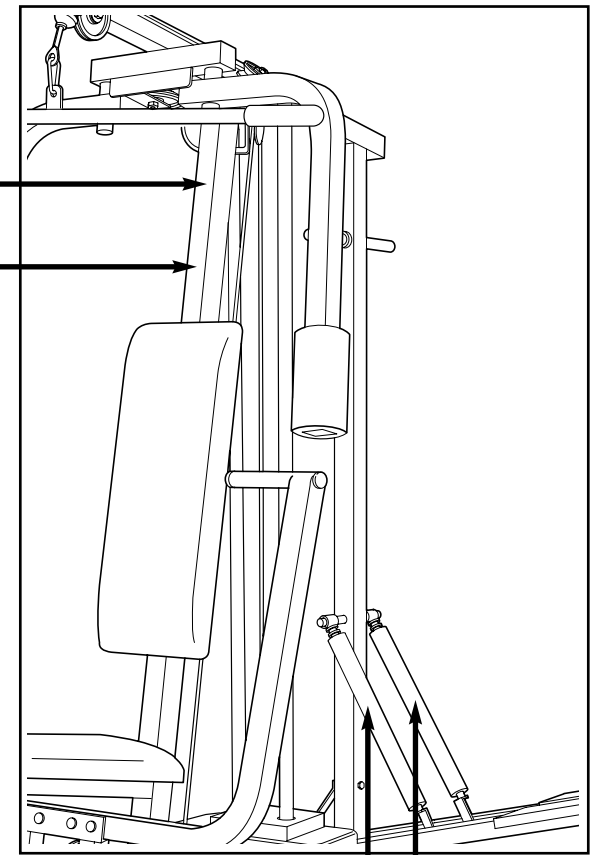

BEFORE YOU BEGIN

Thank you for selecting the versatile WEIDER® 8515 weight system. The WEIDER 8515 weight system offers a selection of weight stations designed to develop every major muscle group of the body. Whether your goal is to tone your body, build dramatic muscle size and strength, or improve your cardiovascular system, the WEIDER 8515 weight system will help you to achieve the specific results you want.

For your benefit, read this manual carefully before using the weight system. If you have additional

questions, please call our Customer Service Department at **08457 089 009**. To help us assist you, please note the product model number and serial number before calling. The model number is WEEVSY87210. The serial number can be found on a decal on the weight system (see the front cover of this manual).

Before reading further, please review the drawing below and familiarise yourself with the parts that are labelled.

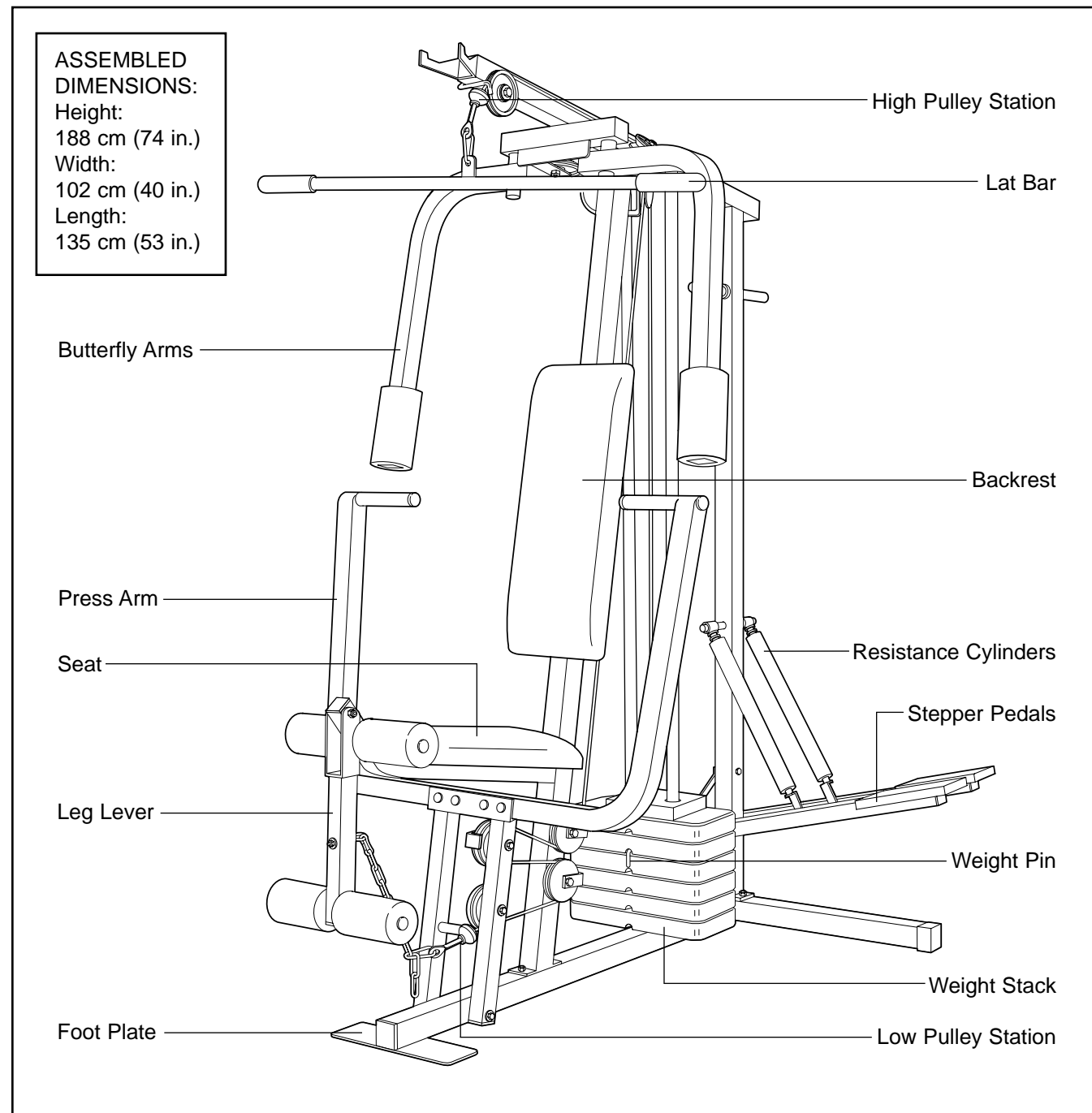

TROUBLESHOOTING AND MAINTENANCE

Inspect and tighten all parts often and replace any worn parts immediately. The weight system can be cleaned using a damp cloth and mild non-abrasive detergent. Do not use solvents.

TIGHTENING THE CABLES

Woven cable, the type of cable used on the weight system, can stretch slightly when it is first used. If there is slack in the cables before resistance is felt, the cables should be tightened. **IMPORTANT: The Weight Pin (26) must be inserted under the middle Weight (25) before the cables can be tightened.** Slack can be removed from the cables three different ways:

- See drawing 1. Tighten the 1/4" Nylon Locknut (2) at the end of the Long Cable (23). To do this you may need to remove the Small "U"-Bracket (67) from the Weight Tube (63). Make sure that the cables are not too tight, or the Top Weight (76) will be lifted off the weight stack.
- See drawing 2. Tighten the 1/4" Nylon Locknut (2) at the end of the Short Cable (58). To do this you may need to remove the 3 1/2" Pulley (15) and the Pulley Covers (89) from the Long "U"-Bracket (57). Make sure that the cables are not too tight, or the Top Weight (76) will be lifted off the weight stack.
- See drawing 2. Move the 3 1/2" Pulley (15) and the Pulley Covers (89) to the other hole in the Long "U"-Bracket (57). Remove the 3/8" Nylon Locknut (21) and the 3/8" x 2" Bolt (12) from the Pulley, and the Long "U"-Bracket. Re-attach the Pulley and Pulley Covers. Be sure that the Cable and Pulley move smoothly.

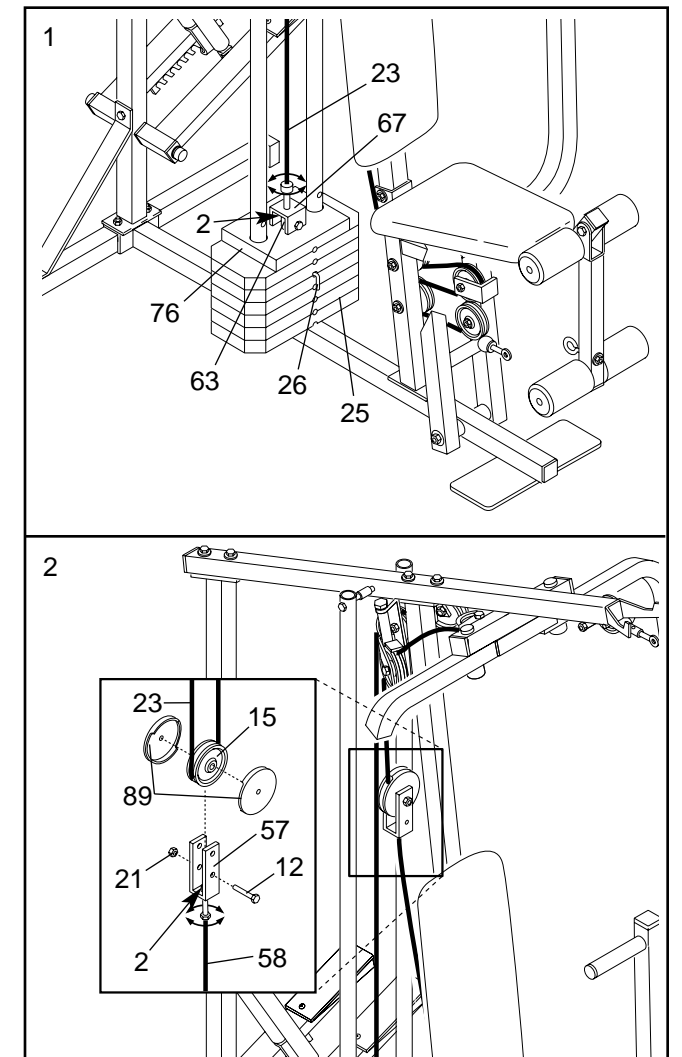

Note: Inspect all cables before each use. If a cable tends to slip off the pulleys often, the cable may have become twisted. Remove the cable and re-install it.

If the cables need to be replaced, see ORDERING REPLACEMENT PARTS on the back cover of this manual. **Replace all cables every two years.**

WEIGHT RESISTANCE CHART

This chart shows the approximate weight resistance at each station. "Top" refers to the 6.5-lb. top weight. The other numbers refer to the 12.5 lbs. weight plates. Weight resistance shown for the butterfly arm station is for each butterfly arm. **Note: The actual resistance at each weight station may vary due to differences in individual weight plates, as well as friction between the cables, pulleys, and weight guides.**

WEIGHT PLATES	PRESS ARM (lbs.)	BUTTERFLY ARM (lbs.)	LEG LEVER (lbs.)	HIGH PULLEY (lbs.)	LOW PULLEY (lbs.)
Top	20	10	15	14	24
1	45	22	36	28	54
2	70	33	54	44	82
3	99	42	75	60	115
4	128	48	96	72	147
5	153	60	115	90	175
6	184	69	137	103	209

Note: 2.2 lbs. = 1 kg

ASSEMBLY



Before beginning assembly, carefully read the following information and instructions:

- Place all parts of the weight system in a cleared area and remove the packing materials; do not dispose of the packing materials until assembly is completed.
- The assembly is divided into four stages: 1) frame assembly, 2) arm assembly, 3) cable assembly, and 4) seat assembly. The hardware for each stage is packaged separately.
- Wait until you begin each assembly stage to open that parts bag.
- For help identifying the small parts used in assembly, **use the PART IDENTIFICATION CHART located in the centre of this manual.** Note: Some small parts may have been pre-attached for shipping. If a part is not in the parts bag, check to see if it has been pre-attached.

As you assemble the weight system, be sure that all parts are oriented as shown in the drawings.

- Tighten all parts as you assemble them, unless instructed to do otherwise.

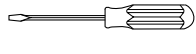
THE FOLLOWING TOOLS (NOT INCLUDED) ARE REQUIRED FOR ASSEMBLY:

- two adjustable spanners** 
- one standard screwdriver** 
- one phillips screwdriver** 
- one rubber mallet** 
- lubricant, such as grease or petroleum jelly, and soapy water will also be needed.**

Assembly will be more convenient if you have the following tools: a socket set, a set of open-end or closed-end spanners, or a set of ratchet spanners.

FRAME ASSEMBLY

- Before beginning assembly, be sure that you have read and understand the information in the box above.**

Press a 2" Square Outer Cap (51) onto each end of the Stabiliser (5). Press a 2" Square Inner Cap (27) into the end of the Base (4).

Turn the Stabiliser (5) so that the long side is positioned as shown.

Insert two 5/16" x 2 3/4" Carriage Bolts (14) up through the Stabiliser (5). Insert a 5/16" x 2 1/2" Carriage Bolt (1) up through the remaining hole in the Stabiliser. Insert two 5/16" x 2 1/2" Carriage Bolts up through the Base (4).

Slide the indicated end of the Base (4) onto the 5/16" x 2 3/4" Carriage Bolts (14) in the Stabiliser (5). Slide the Rear Upright (56) onto the Carriage Bolts. **The high side of the bracket on the Rear Upright must be on the side shown.** Hand tighten a 5/16" Nylon Locknut (3) onto each Carriage Bolt. **Do not tighten the Nylon Locknuts yet.**

Wet the handles on the Rear Upright (56) with soapy water. Slide a 5" Plastic Hand Grip (31) onto each handle.

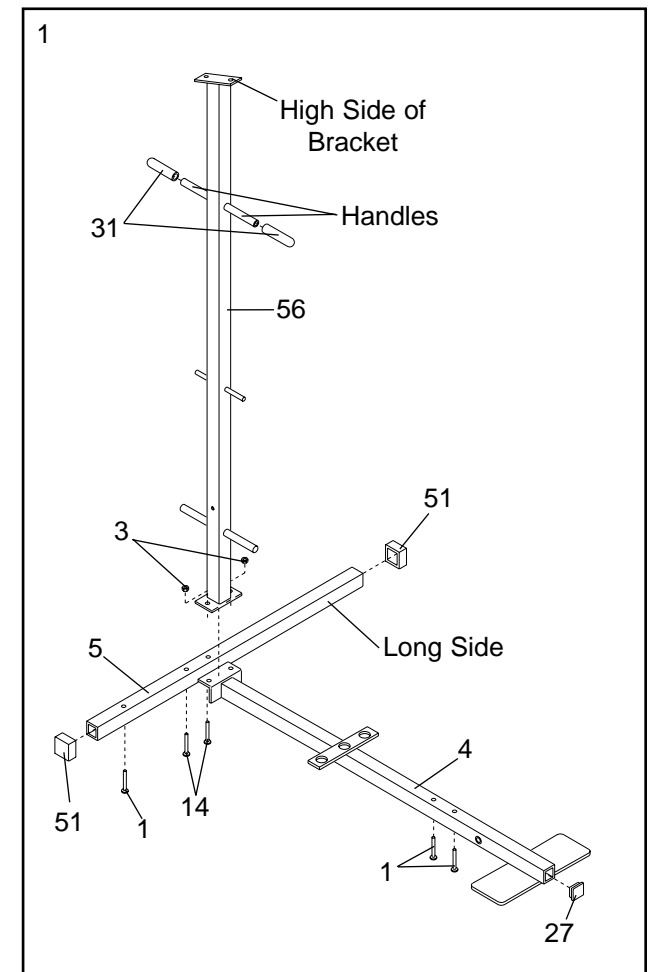

- Slide the Front Upright (42) onto the 5/16" x 2 1/2" Carriage Bolts (1) in the Base (4). Hand tighten a 5/16" Nylon Locknut (3) onto each Carriage Bolt. **Do not tighten the Nylon Locknuts yet.**

Press a 1" Square Inner Cap (65) into the Front Upright (42).

Attach the slotted end of the Brace (87) to the 5/16" x 2 1/2" Carriage Bolt (1) in the Stabiliser (5). Hand tighten a 5/16" Nylon Locknut (3) onto the Bolt. **Do not tighten the Nylon Locknut yet.**

Attach the other end of the Brace (87) to the Rear Upright (56) with a 5/16" x 2 3/4" Bolt (11), a 5/16" Washer (8), and a 5/16" Nylon Locknut (3). **Do not tighten the Nylon Locknut yet.**

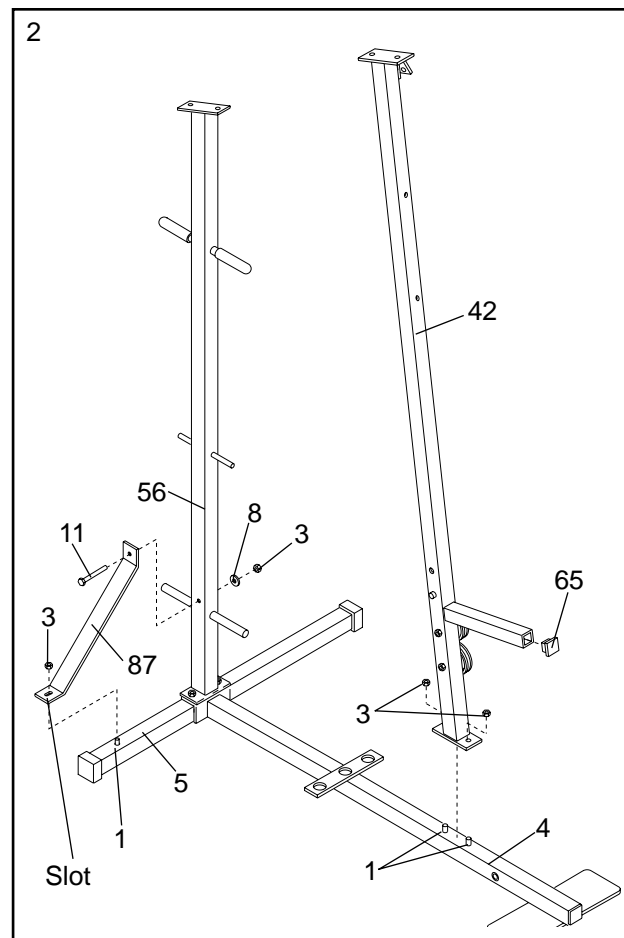

- Press a 2" Square Inner Cap (27) into the end of the Top Frame (55). Press a 1 3/4" Square Inner Cap (44) into each end of the crossbar on the Top Frame. Press two 1" Round Inner Caps (49) into the top of the crossbar.

Attach the Top Frame (55) to the Front Upright (42) and the Rear Upright (56) with four 5/16" x 2 3/4" Bolts (11), four 5/16" Washers (8), and four 5/16" Nylon Locknuts (3).

Tighten all Nylon Locknuts used in steps 1 through 3.

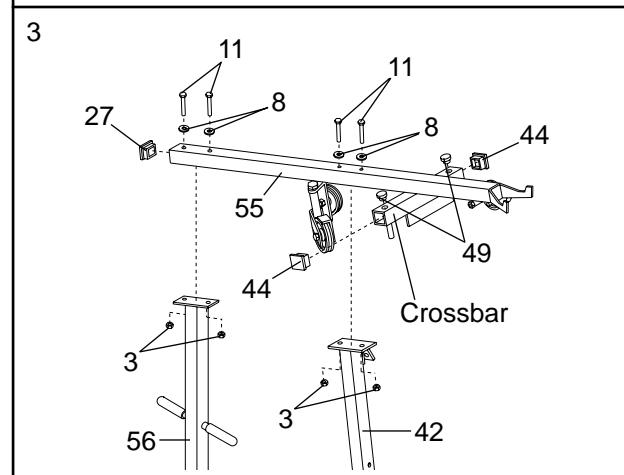

- Press two 1 1/2" Bushings (82) into the Left Pedal (79). Attach a Pedal Cover (81) to the Left Pedal with a 1/2" Metal Screw (77).

Assemble the Right Pedal (not shown) in the same manner.

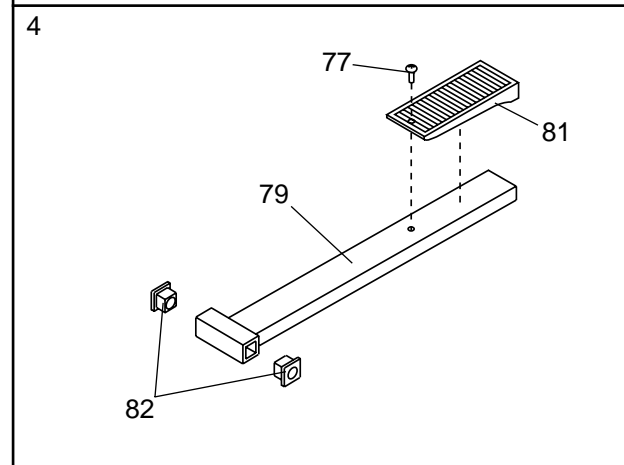

LOCKING THE WEIGHT STACK

When the weight system is not in use, the Lock Pin (90) and Lock (91) should be attached. Insert the Lock Pin through a Weight Guide (62). Attach the Lock to the Lock Pin.

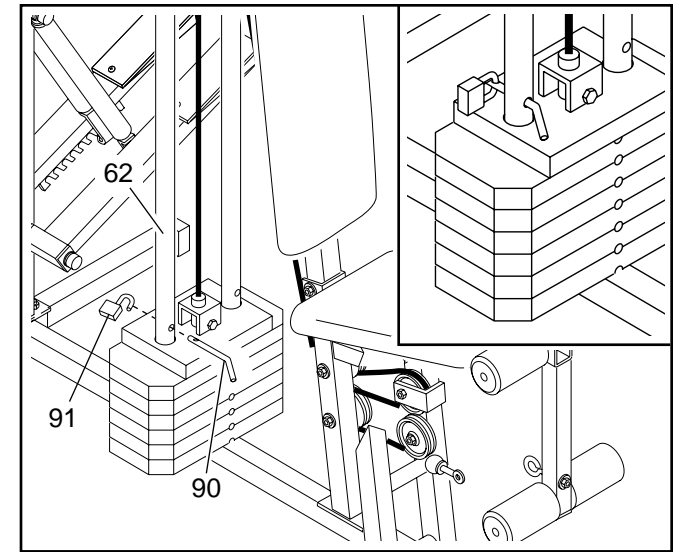

ATTACHING AND REMOVING THE SEAT

Set the bracket on the Seat Frame (36) onto the indicated pins on the Front Upright (42). Attach the Seat Frame to the Front Upright with the 5/16" x 2 3/4" Carriage Bolt (14) and the Seat Knob (40).

For some exercises, the Seat (13) must be removed. First, be sure that the chain is not attached to the leg lever. Next, remove the Seat Knob (40) and the 5/16" x 2 3/4" Carriage Bolt (14) from the Seat Frame (36). Lift the Seat Frame off the Front Upright (42).

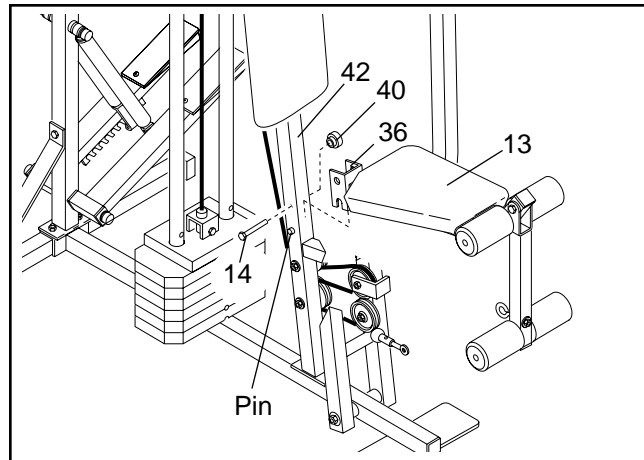

ATTACHING THE LEG LEVER TO THE LOW PULLEY STATION

To use the Leg Lever (29), the seat must be attached to the front upright (see ATTACHING AND REMOVING THE SEAT above).

Attach one end of the Chain (52) to the Short Cable (58) with a Cable Clip (53). Attach the other end of the Chain to the 5/16" x 2" Eyebolt (35) with a Cable Clip.

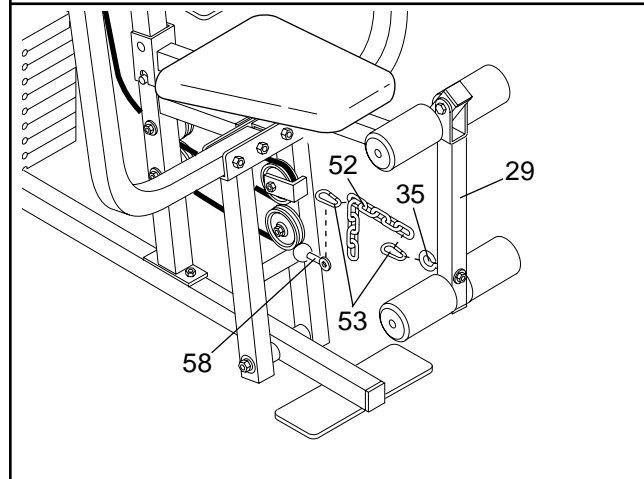

CHANGING THE STEPPING RESISTANCE

To change the stepping resistance, first lift the Right and Left Pedals (78, 79) off the hooks at the lower ends of the Resistance Cylinders (80). Move the hooks to different slots under the Pedals. **Make sure that the hooks are fully inserted into the same slots on both Pedals.** The farther the hooks are moved from the Rear Upright (56), the greater the resistance will be. **WARNING: The Resistance Cylinders become very hot during use. Allow the Resistance Cylinders to cool before touching them.**

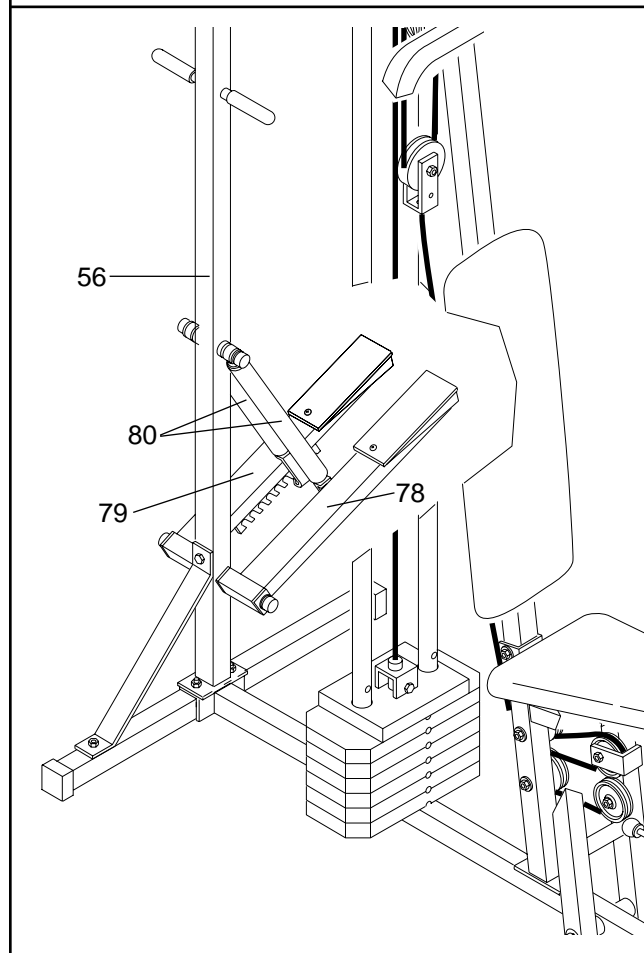

FRAME ASSEMBLY

5. Lubricate the pedal axles on the Rear Upright (56). Slide the Left Pedal (79) onto the left pedal axle, and the Right Pedal (78) onto the right pedal axle. **Note: Make sure that the Pedals are on the correct sides; the slotted brackets must be on the insides of the Pedals.** Hold a 1" Retainer (69) and a 1" Round Cover Cap (70) against the end of the left pedal axle. The teeth on the Retainer must bend outward (see the inset drawing). Tap the Retainer and the Round Cover Cap onto the pedal axle. Attach the Right Pedal in the same manner.

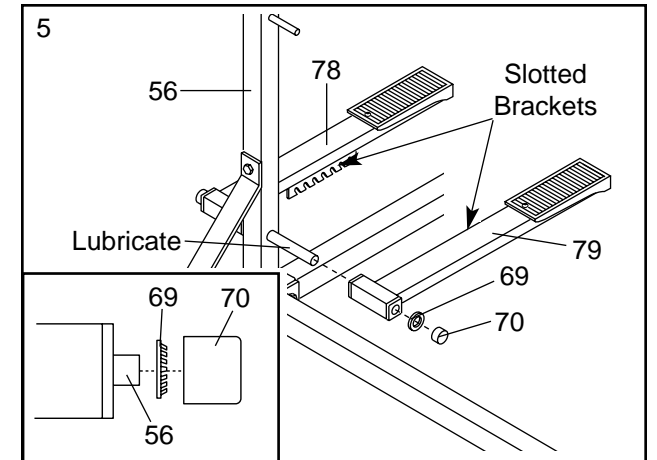

6. Lubricate the cylinder axles on the Rear Upright (56). Slide a 5/8" Spacer (86) and a Resistance Cylinder (80) onto each cylinder axle. **Be sure that the decals on the Resistance Cylinders are facing the pedals and that the Spacer is turned as shown in the inset drawing.** Hold a 5/8" Retainer (84) and a 5/8" Round Cover Cap (85) against the end of the right cylinder axle. The teeth on the Retainer must bend outward (see the inset drawing). Tap the Retainer and the Round Cover Cap onto the cylinder axle.

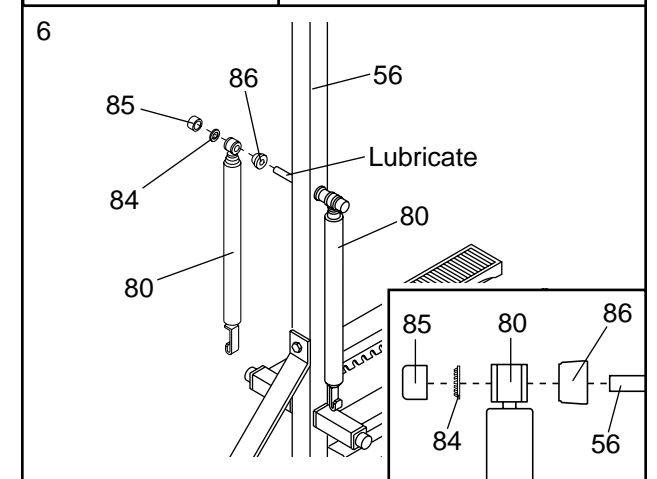

Tap a 5/8" Retainer (84) and a 5/8" Round Cover Cap (85) onto the left cylinder axle in the same manner.

7. Raise the Left Pedal (79) and rest it on the hook at the lower end of the left Resistance Cylinder (80). The hook must be in one of the slots under the Left Pedal.

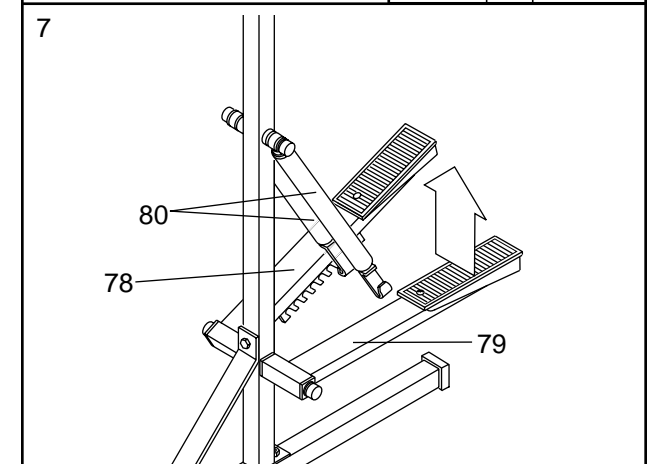

Raise the Right Pedal (78) and rest it on the hook at the lower end of the right Resistance Cylinder (80). **Make sure that the hooks are in the same position under both Pedals.**

8. Set two Weight Bumpers (19) onto the bracket on the Base (4) as shown.

Stack six Weights (25) onto the Weight Bumpers (19). **Make sure that the Weights are turned so the pin grooves are all on the same side.**

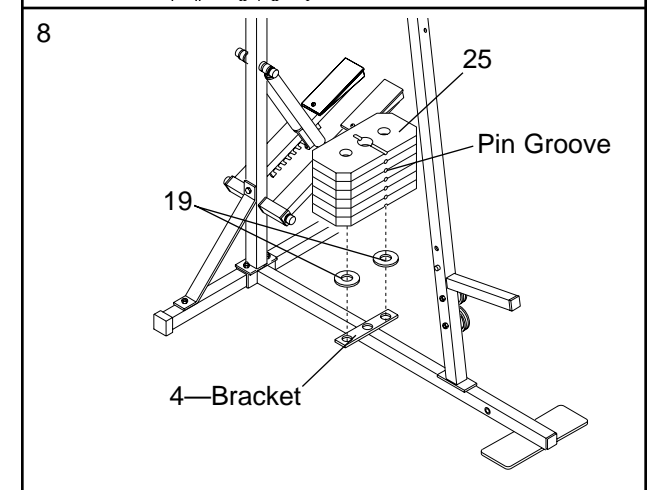

9. Press the Weight Tube Bumper (64) into the end of the Weight Tube (63). Insert the Weight Tube into the stack of Weights (25). **Be sure that the pins on the Weight Tube are sitting in the pin grooves in the top Weight.**

Lubricate the insides of the holes in the Top Weight (76). Set the Top Weight onto the stack of Weights (25). Insert both Weight Guides (62) into the stack of Weights. **Be sure that the holes in the Weight Guides are at the top, as shown.**

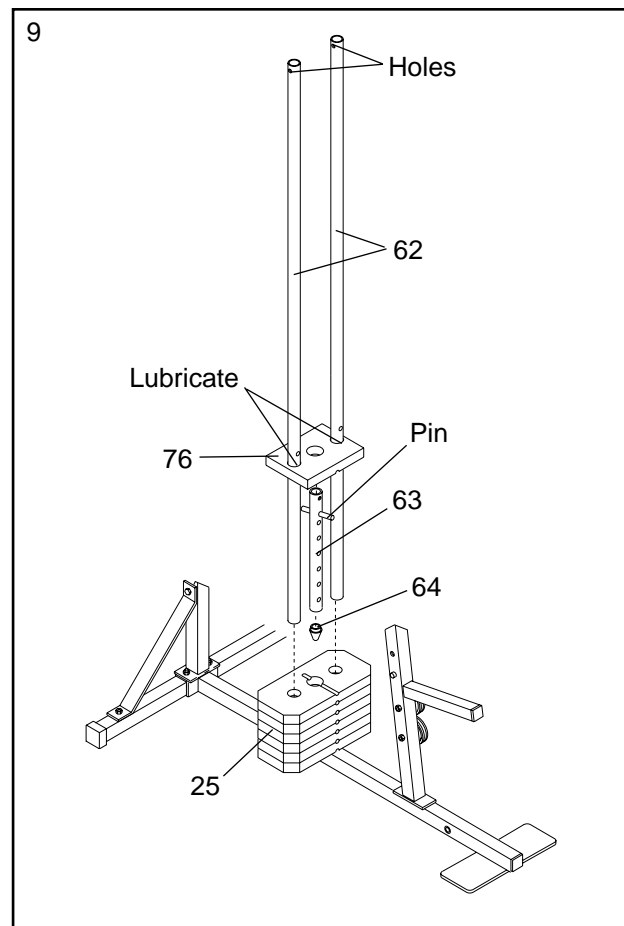

10. Attach the upper ends of the Weight Guides (62) to the Top Frame (55) with the 5/16" x 6" Bolt (60), two 1/2" x 3/4" Spacers (61), and a 5/16" Nylon Locknut (3).

Be sure that the Pulley Bracket (20) is in front of the right Weight Guide (62) as shown.

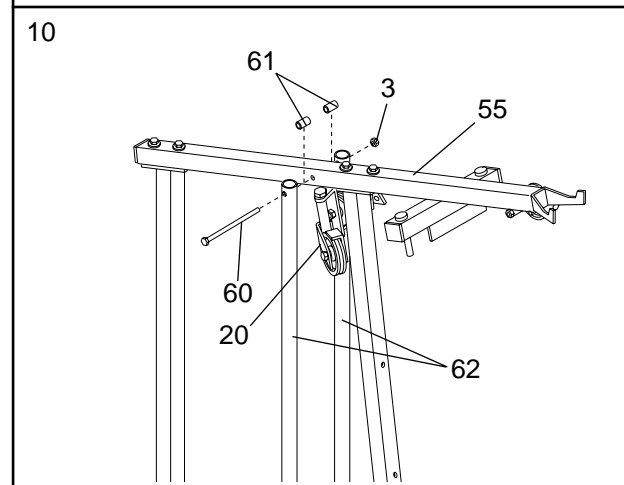

11. Press a 1" x 7/8" Plastic Bushing (75) onto each welded spacer on the Press Frame (17). Slide the Press Frame into place on the Base (4). **Note: This will be a tight fit. The Plastic Bushings should fit onto each end of the indicated tube in the Base. Be sure that the Pulleys (15) are on the indicated side.**

Lubricate the 3/8" x 8" Bolt (59). Attach the Press Frame (17) to the Base (4) with the 3/8" x 8" Bolt and a 3/8" Nylon Locknut (21).

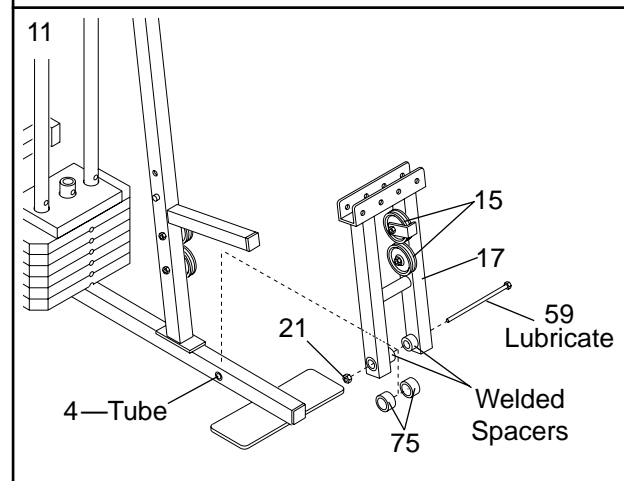

HOW TO USE THE WEIGHT SYSTEM

The instructions below describe how each part of the weight system can be adjusted. **IMPORTANT: When attaching the lat bar or nylon strap, make sure that the attachments are in the correct starting position for the exercise to be performed. If there is any slack in the cables or chain as an exercise is performed, the effectiveness of the exercise will be reduced.**

CHANGING THE WEIGHT SETTING

To change the weight setting of the weight stack, insert the Weight Pin (26) under the desired Weight (25). Make sure to insert the Weight Pin until the bent end of the Weight Pin is touching the Weights, and turn the bent end downward. The weight setting can be changed from 6.5 lbs. to 81.5 lbs., in increments of 12.5 lbs. **Note: Due to the cables and pulleys, the amount of resistance at each exercise station may vary from the weight setting. Use the WEIGHT RESISTANCE CHART on page 20 to find the approximate amount of resistance at each weight station.**

Note: 1 kg = 2.2 lbs

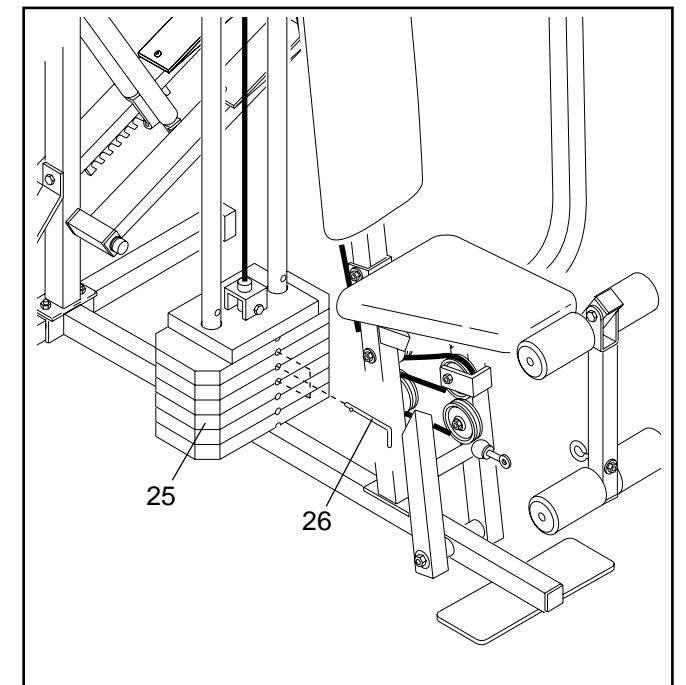

ATTACHING THE LAT BAR OR NYLON STRAP TO THE HIGH PULLEY STATION

Attach the Lat Bar (54) to the Long Cable (23) with a Cable Clip (53). For some exercises, the Chain (52) should be attached between the Lat Bar and the Long Cable with two Cable Clips. **Adjust the length of the Chain between the Lat Bar and the Long Cable so the Lat Bar is in the correct starting position for the exercise to be performed.**

The Nylon Strap (not shown) can be attached in the same manner.

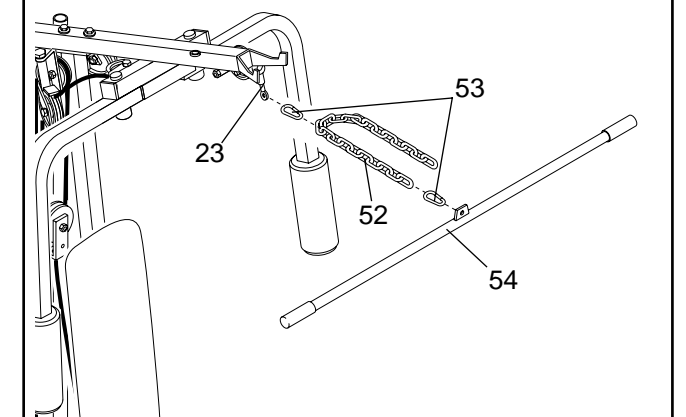

ATTACHING THE LAT BAR OR NYLON STRAP TO THE LOW PULLEY STATION

Attach the Lat Bar (54) to the Short Cable (58) with a Cable Clip (53). For some exercises, the Chain (52) should be attached between the Lat Bar and the Short Cable with two Cable Clips. **Adjust the length of the Chain between the Lat Bar and the Short Cable so the Lat Bar is in the correct starting position for the exercise to be performed.**

The Nylon Strap (not shown) can be attached in the same manner.

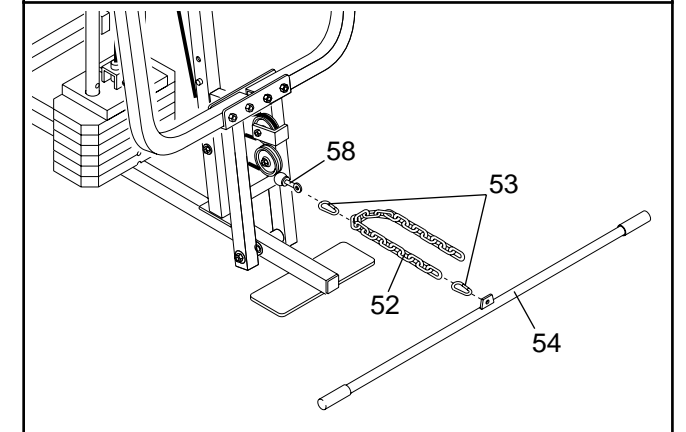

28. Make sure that all parts have been properly tightened. The use of the remaining parts will be explained in HOW TO USE THE WEIGHT SYSTEM, beginning on page 17.

Before using the weight system, pull each cable a few times to be sure that the cables move smoothly over the pulleys. If one of the cables does not move smoothly, find and correct the problem. **IMPORTANT: If the cables are not properly installed, they may be damaged when heavy weight is used. See the CABLE DIAGRAM on page 22 for proper cable routing. If there is any slack in the cables, the cables should be tightened. See TROUBLESHOOTING AND MAINTENANCE.**

ARM ASSEMBLY

12. Wet the handle of one Press Arm (46) with soapy water. Slide a 5" Plastic Grip (31) onto the handle. Press a 1" Round Inner Cap (49) into the other end of the handle. Press a 1 3/4" Square Inner Cap (44) into the top of the Press Arm.

Attach the Press Arm (46) to one side of the Press Frame (17) with two 5/16" x 2 1/2" Bolts (22) and two 5/16" Nylon Locknuts (3).

Assemble the other Press Arm (46) in the same manner.

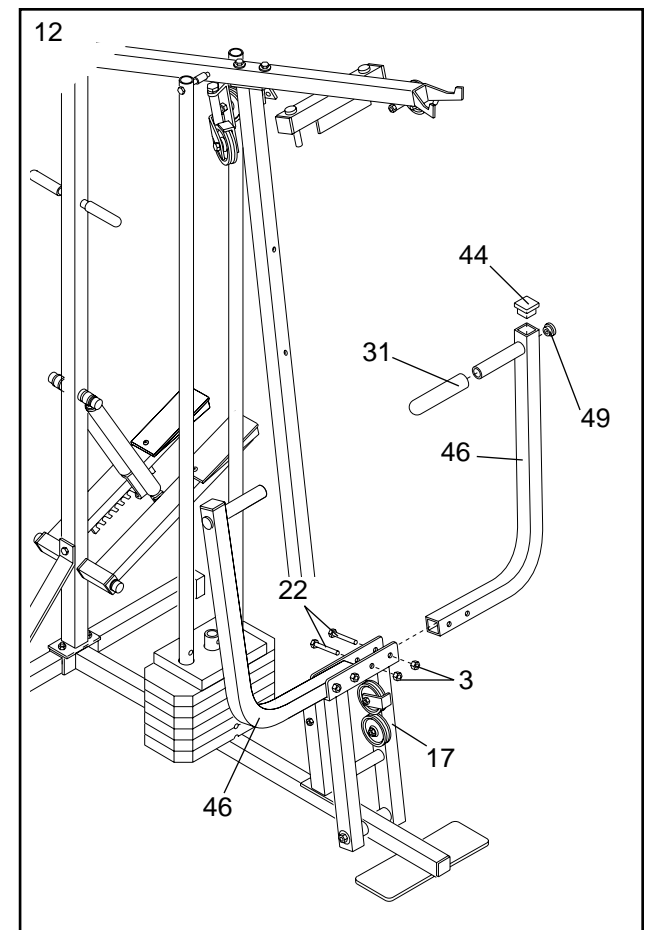

13. Lubricate both axles on the Top Frame (55).

Slide the Right Arm (48) onto the right axle. **Note: Be careful not to confuse the Right Arm with the Left Arm (47); note the position of the "V" Pulley (6) to identify the Right Arm. Be sure that the upper end of the Right Arm is behind the indicated bracket on the Top Frame (55).**

Tap two 1" Retainers (69) and a 1" Round Cover Cap (70) onto the axle. **Be sure that the teeth on the Retainers bend toward the Cover Cap, as shown in the inset drawing.**

Attach the Left Arm (47) in the same manner.

Press 1 3/4" Square Inner Caps (44) into the lower ends of the Left and Right Arms (47, 48). Wet the lower end of each Arm with soapy water. Slide a 10" Pad (45) onto the lower end of each Arm.

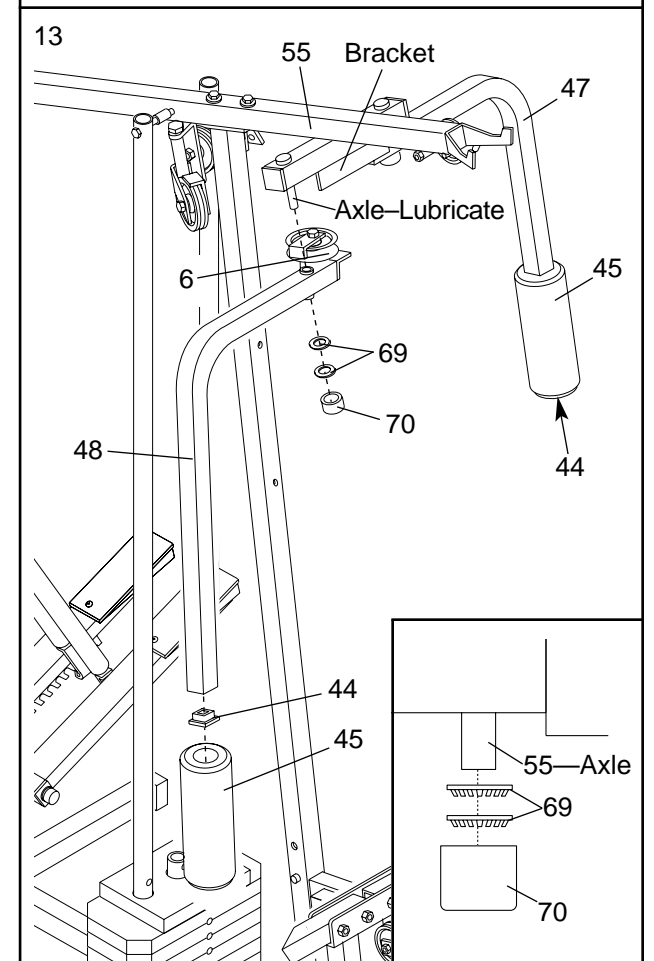

As you assemble the cables and pulleys in steps 14 through 22, please refer to the CABLE DIAGRAM on page 22 of this manual.

14. Route the Long Cable (23) around the 3 1/2" Pulley (15) attached to the Top Frame (55). **Be sure that the end of the Cable with the ball is on the indicated side of the Pulley and that the Cable is between the Pulley and the hook on the Top Frame.** Tighten the 3/8" x 3 3/4" Bolt (71) and the 3/8" Nylon Locknut (not shown).

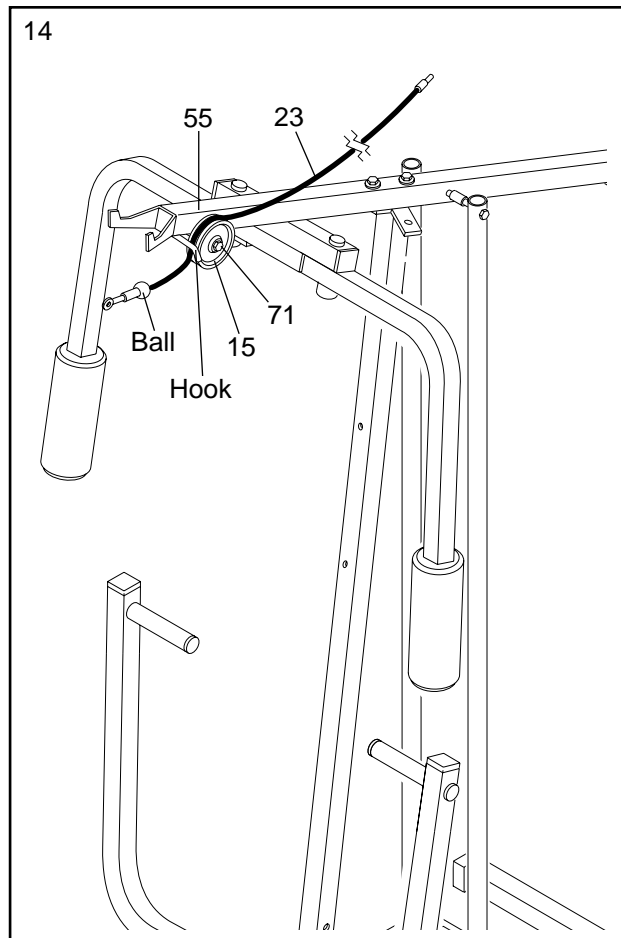

15. Wrap the Long Cable (23) around a "V"-Pulley (6). Attach the "V"-Pulley and a Long Cable Trap (50) to the indicated bracket on the Front Upright (42) with a 3/8" x 2 1/2" Bolt (7) and a 3/8" Nylon Locknut (21).

Route the Long Cable (23) around the "V"-Pulley (6) on the Left Arm (47). Tighten the 3/8" x 2 1/2" Bolt (7) and the 3/8" Nylon Locknut (not shown). **Be sure that the Cable is in the groove of the Pulley and that the Long Cable Trap (50) is turned to hold the Cable in place.**

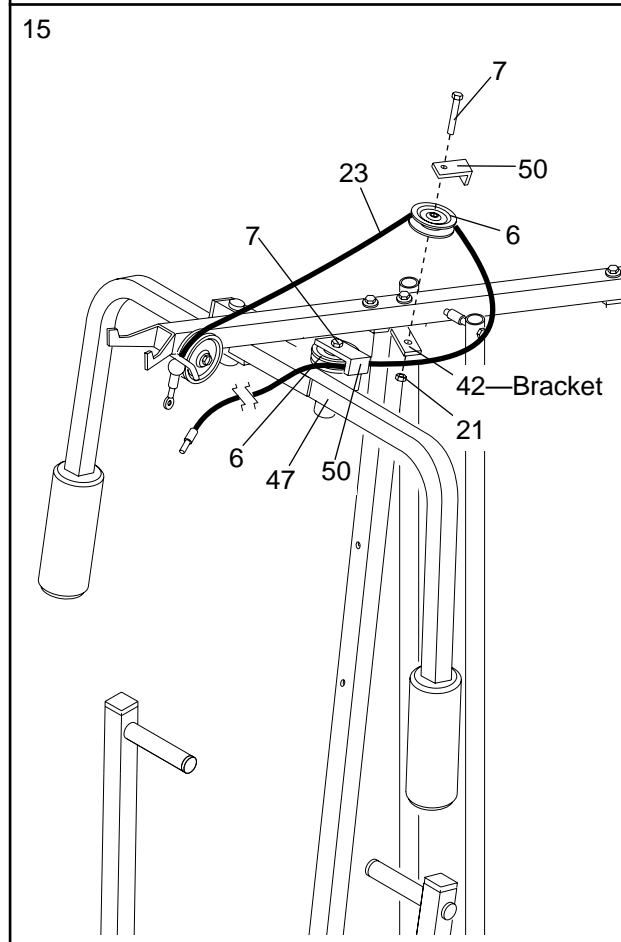

25. Press a 1 1/2" Square Inner Cap (32) into the Leg Lever (29).

Lubricate the 5/16" x 2 1/4" Bolt (33). Attach the Leg Lever (29) to the Seat Frame (36) with the 5/16" x 2 1/4" Bolt and a 5/16" Nylon Locknut (3).

Insert the 3/8" x 2" Eyebolt (35) into the Leg Lever (29) from the direction shown. Tighten a 3/8" Nylon Locknut (21) with a 3/8" Washer (9) onto the Eyebolt.

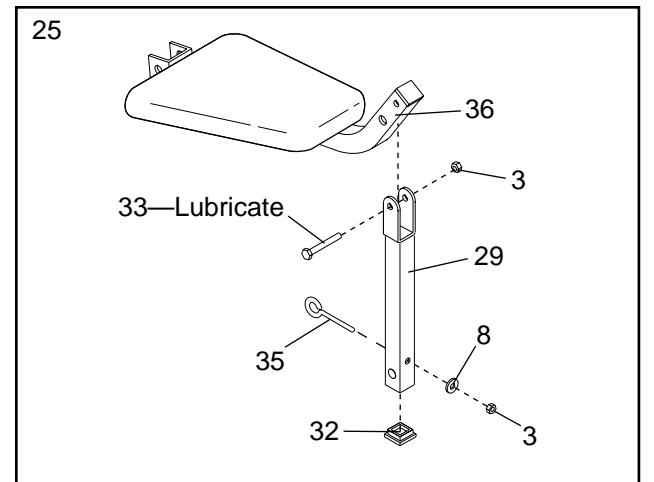

26. Rest the Seat Frame (36) on the indicated pin in the Front Upright (42). Attach the Seat Frame to the Front Upright with a 5/16" x 2 3/4" Carriage Bolt (14) and the Seat Knob (40).

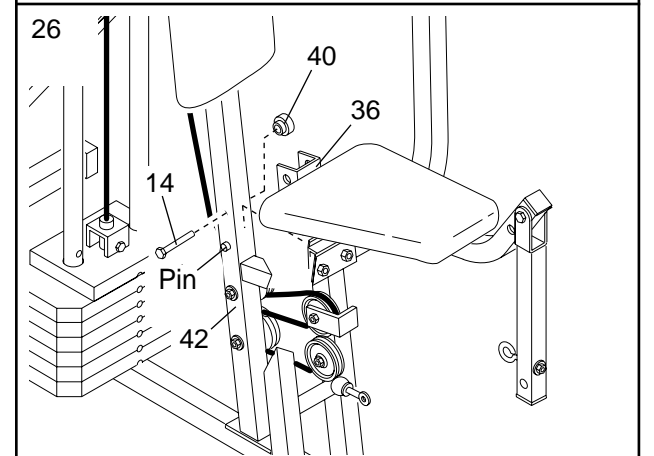

27. Press 3/4" Round Inner Caps (34) into the ends of both 12 1/2" Pad Tubes (28).

Insert one 12 1/2" Pad Tube (28) into the Seat Frame (36). Slide a 5 1/2" Pad (30) onto each end of the Pad Tube.

Insert the other 12 1/2" Pad Tube (28) into the Leg Lever (29). Slide a 5 1/2" Pad (30) onto each end of the Pad Tube.

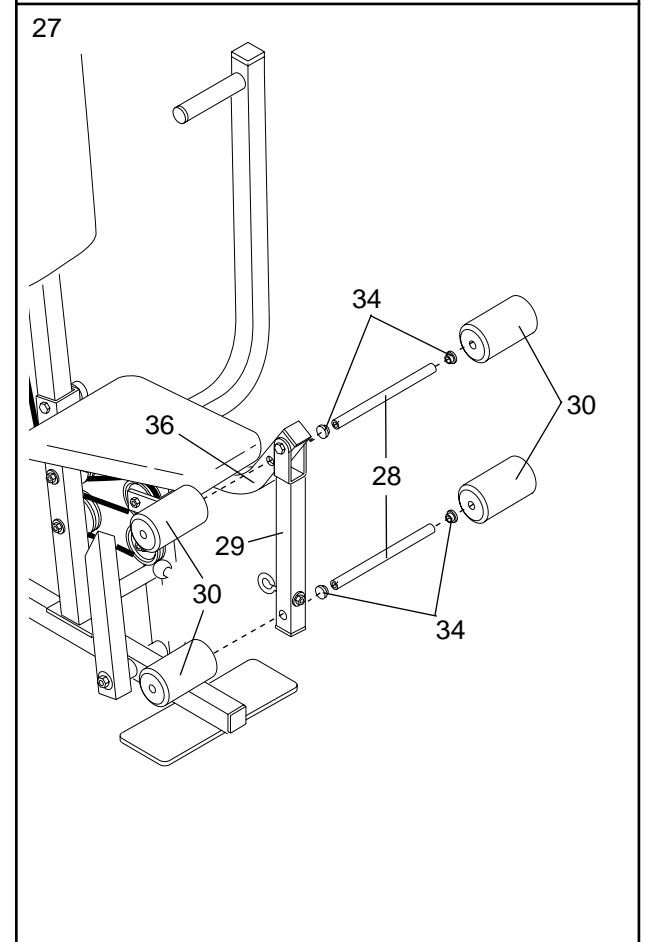

22. Attach the Long Cable (23) to the Small "U"-Bracket (67) with a 1/4" Nylon Locknut (2) and a 1/4" Washer (10). **Do not completely tighten the Nylon Locknut. It should be threaded onto the end of the Cable so only a couple of threads are showing above the Nylon Locknut, as shown in the inset drawing.**

Attach the Small "U"-Bracket (67) to the Weight Tube (63) with the 5/16" x 1 3/4" Bolt (72) and a 5/16" Nylon Locknut (3).

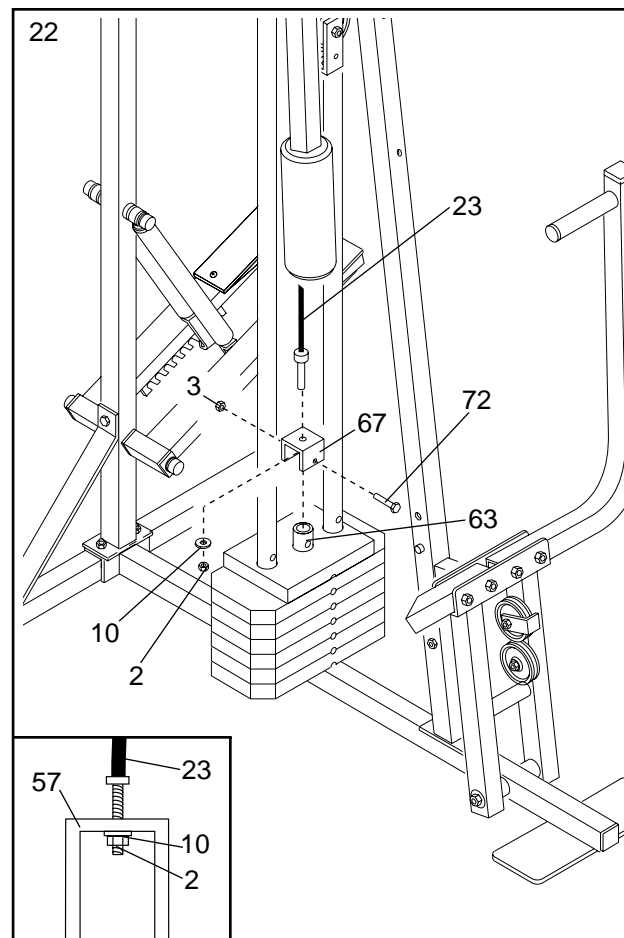

23. Attach the Backrest (41) to the Front Upright (42) with two 1/4" x 2 1/2" Screws (43) and two 1/4" Washers (10).

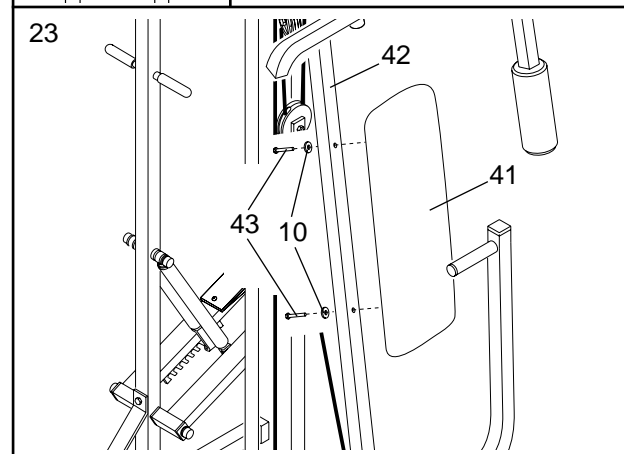

24. Press a 1 1/2" Square Inner Cap (32) into the Seat Frame (36).

Insert the 1/4" x 2" Carriage Bolt (38) through the centre hole in the Seat Plate (37). Attach the Seat Plate to the Seat (13) with two 1/4" x 1/2" Screws (18).

Insert the 1/4" x 2" Carriage Bolt (38) into the indicated hole in the Seat Frame (36). Tighten a 1/4" Nylon Locknut (2) with a 1/4" Washer (10) onto the Carriage Bolt.

Attach the other end of the Seat (13) to the Seat Frame (36) with the 1/4" x 2" Screw (24) and a 1/4" Washer (10).

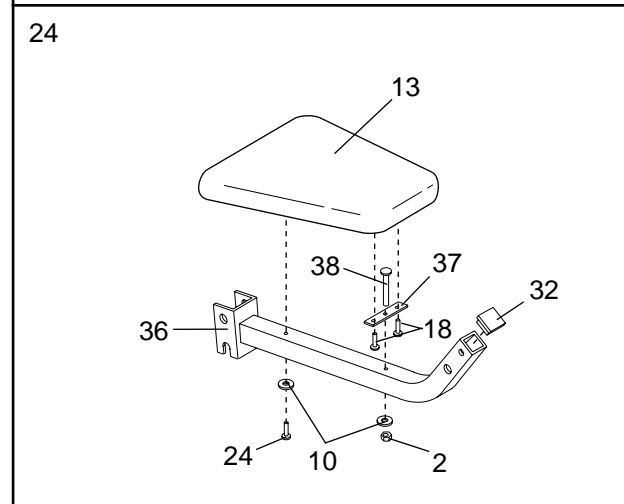

16. Route the Long Cable (23) around the "V"-Pulley (6) on the Right Arm (48). **Be sure that the Cable is in the groove of the "V"-Pulley and that the Long Cable Trap (50) is turned to hold the Cable in place.** Tighten the 3/8" x 2 1/2" Bolt (7) and the 3/8" Nylon Locknut (not shown).

Route the Long Cable (23) around the 3 1/2" Pulley (15) attached to the Pulley Bracket (20). **Be sure that the Cable is in the groove of the Pulley and that the Cable Trap (66) is turned to hold the Cable in place.** Tighten the 3/8" Nylon Locknut (21) and the 3/8" x 2" Bolt (not shown).

Be sure that the 5/16" x 5" Bolt (68) is tightened.

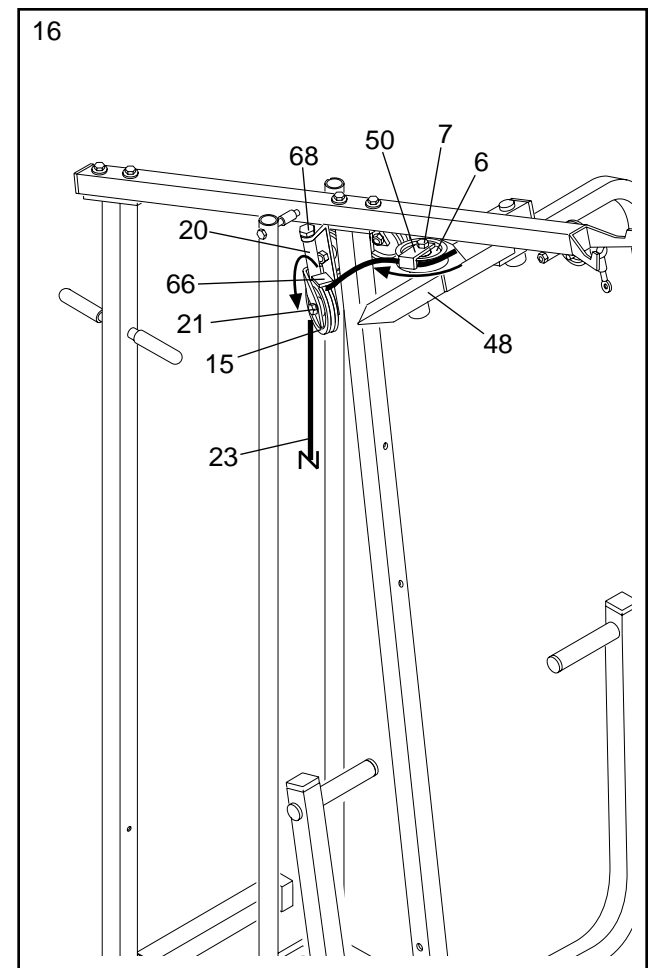

17. Refer to the inset drawing. If the 3 1/2" Pulley (15) is pre-attached to the Long "U" Bracket (57), remove it. Wrap the Long Cable (23) around the 3 1/2" Pulley. Attach the Pulley and two Pulley Covers (89) to the indicated hole in the Long "U"-Bracket (57) with a 3/8" x 2" Bolt (12) and a 3/8" Nylon Locknut (21). **Make sure that the Pulley Covers are turned so the wide tabs are on the indicated side.**

Be sure that the Cable is in the groove of the Pulley and that the Cable and Pulley move smoothly.

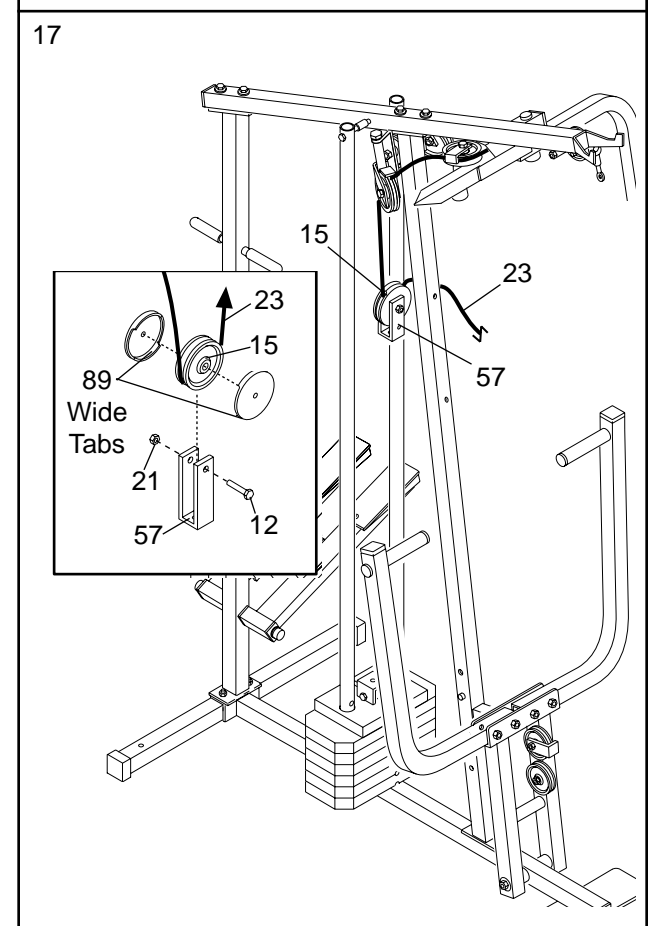

18. Route the Long Cable (23) around the 3 1/2" Pulley (15) attached to the bracket on the Top Frame (55). Tighten the 3/8" x 2" Bolt (12) and the 3/8" Nylon Locknut (21). **(Note: This Pulley is pre-assembled. It has been shown disassembled for easy part identification.) Be sure that the Cable is in the groove of the Pulley and that the Cable and Pulley move smoothly.**

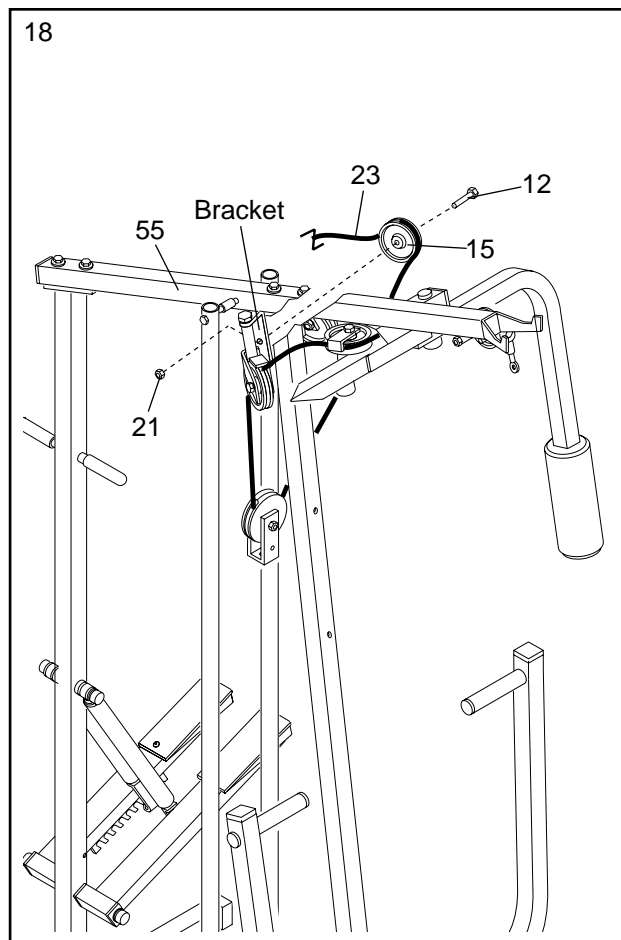

19. Remove the 3 1/2" Low Pulley (88) from the Press Frame (17). Re-attach the Pulley with a 5/8" x 9/16" Spacer (73) between the Pulley and the Press Frame. **Finger tighten the 3/8" Nylon Locknut (21).**

Route the Short Cable (58) under the 3 1/2" Low Pulley (88) attached to the lower hole in the Press Frame (17). **Be sure that the end of the Cable with the ball is on the indicated side of the Press Frame and that the Cable is between the Pulley and the crossbar on the Press Frame.** Tighten the 3/8" Nylon Locknut (21).

If the indicated 3 1/2" Pulley (15) is pre-attached to the Front Upright (42), remove it. Route the Short Cable (58) around the Pulley. Attach the Pulley and two Pulley Covers (89) to the lower hole in the Front Upright with the 3/8" Nylon Jam Nut (92), the 3/8" Washer (9) and the 3/8" x 3 3/4" Bolt (71).

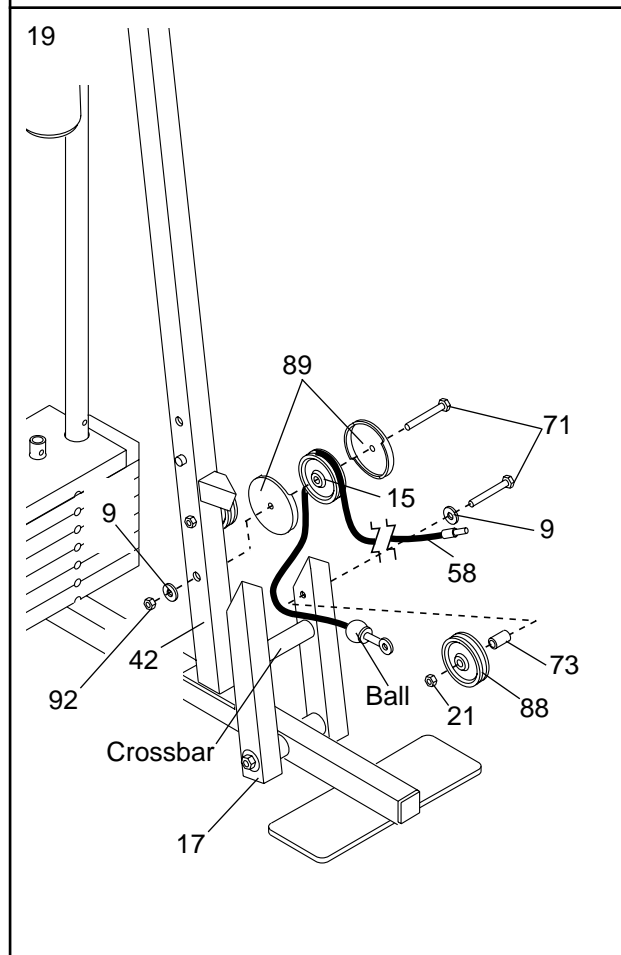

20. Route the Short Cable (58) around the 3 1/2" Pulley (15) attached to the upper hole in the Press Frame (17). **Be sure that the Cable Trap (66) is in the "3 o'clock" position and that the Cable is routed around the Pulley as shown.** Tighten the 3/8" Nylon Locknut (21) and the 3/8" x 3 3/4" Bolt (not shown).

If the indicated 3 1/2" Pulley (15) is pre-attached to the Front Upright (42), remove it. Route the Short Cable (58) around the 3 1/2" Pulley. Attach the Pulley and two Pulley Covers (89) to the upper hole in the Front Upright with the 3/8" Nylon Jam Nut (92), the 3/8" Washer (9) and the 3/8" x 3 3/4" Bolt (71). **Be sure that the Cable is routed around the Pulley as shown.**

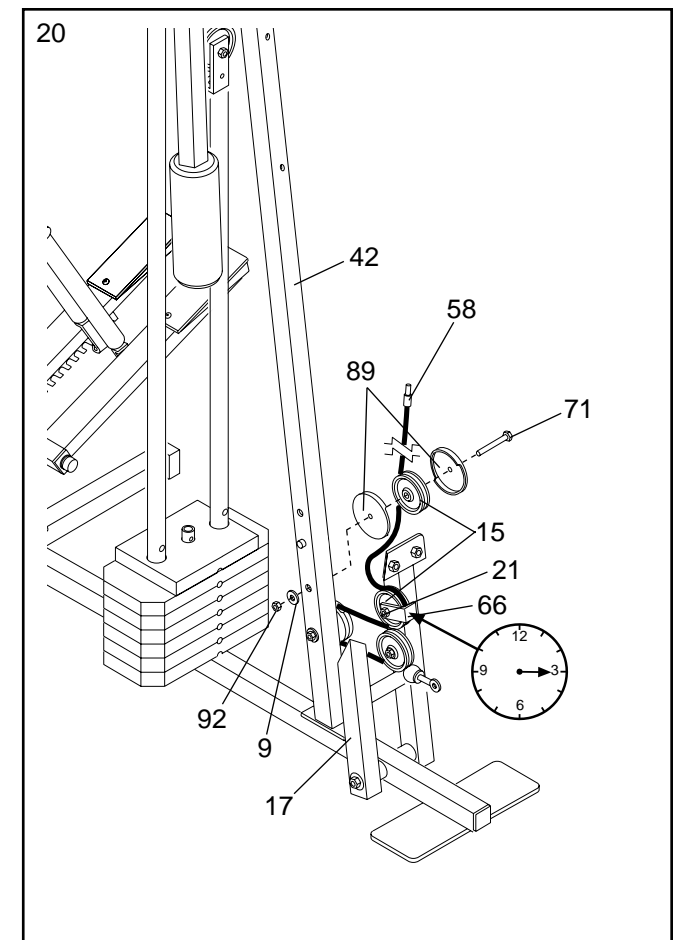

21. Attach the end of the Short Cable (58) to the Long "U"-Bracket (57) with a 1/4" Nylon Locknut (2) and a 1/4" Washer (10). **Do not completely tighten the Nylon Locknut. It should be threaded onto the end of the Cable so only a couple of threads are showing above the Nylon Locknut, as shown in the inset drawing.**

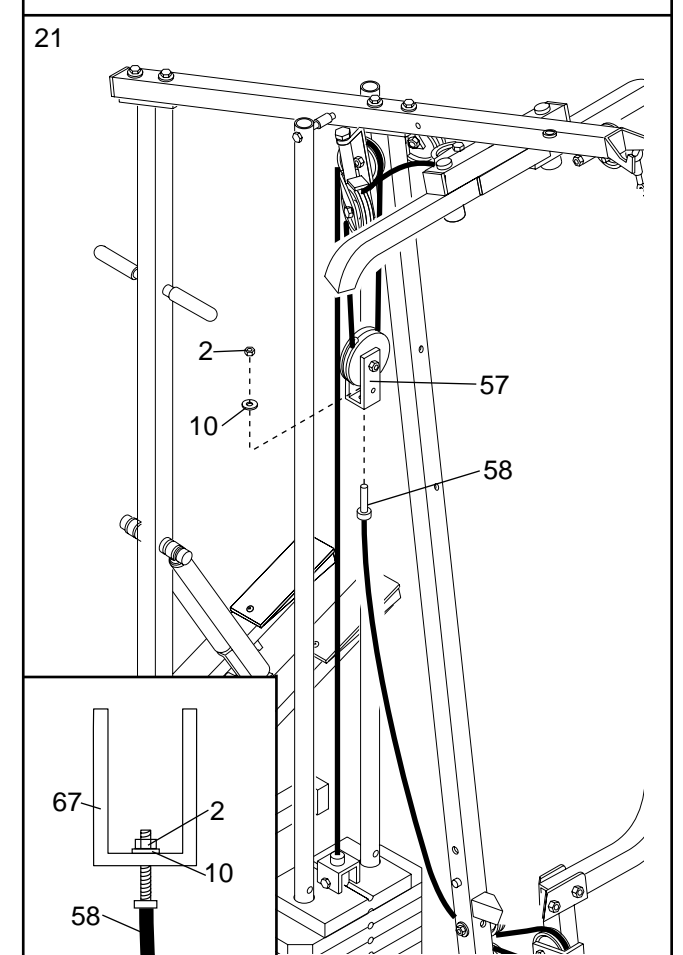

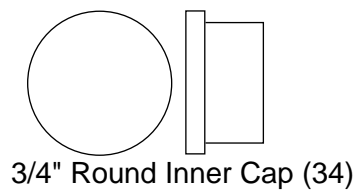

3/4" Round Inner Cap (34)

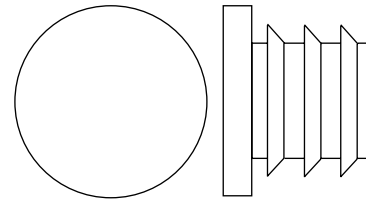

1" Round Inner Cap (49)

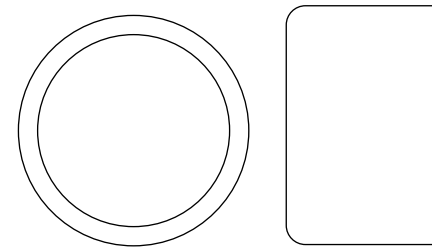

1" Round Cover Cap (70)

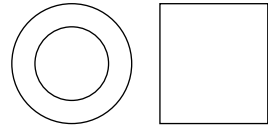

5/8" x 9/16" Spacer (73)

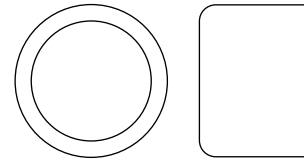

5/8" Round Cover Cap (85)

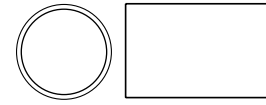

1/2" x 3/4" Spacer (61)

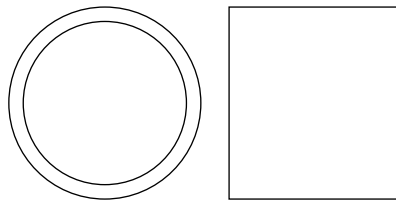

1" x 7/8" Plastic Bushing (75)

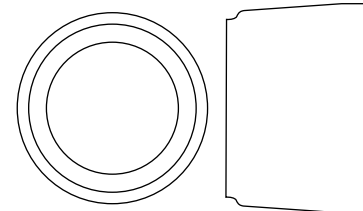

5/8" Spacer (86)

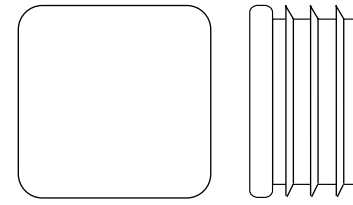

1" Square Inner Cap (65)

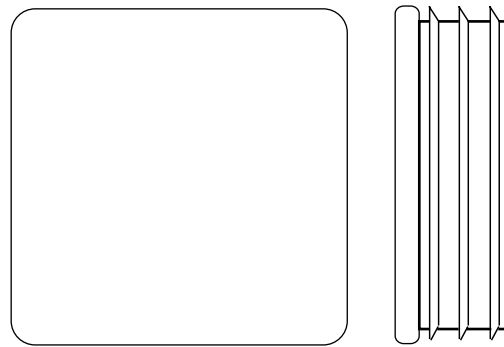

1 3/4" Square Inner Cap (44)

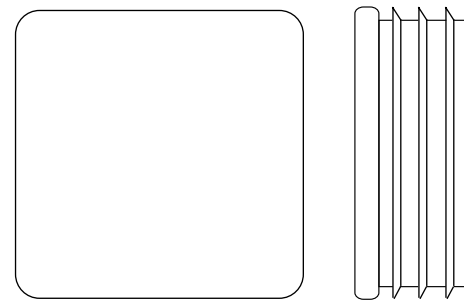

1 1/2" Square Inner Cap (32)

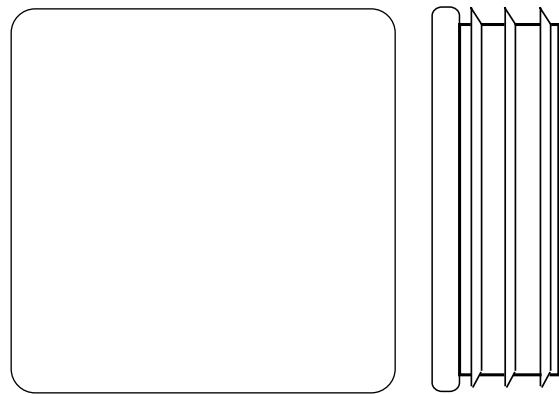

2" Square Inner Cap (27)

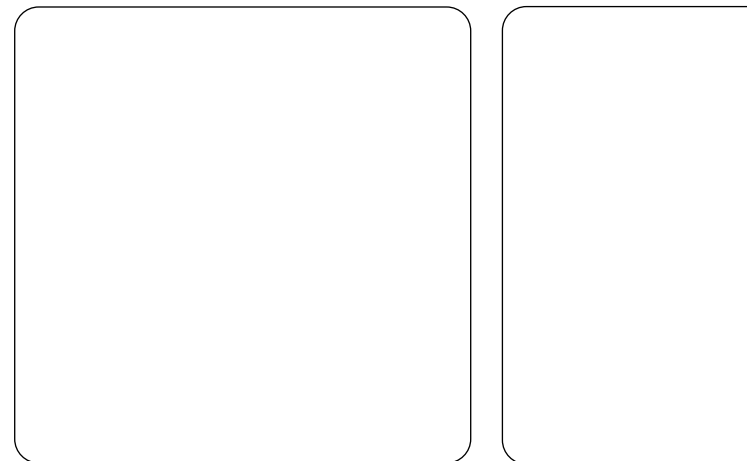

2" Square Outer Cap (51)

REMOVE THIS PART IDENTIFICATION CHART FROM THE MANUAL

This chart is provided to help you identify the small parts used in assembly. **Important: Some parts may have been pre-assembled for shipping purposes. If you cannot find a part in the parts bags, check to see if it has been pre-assembled.**

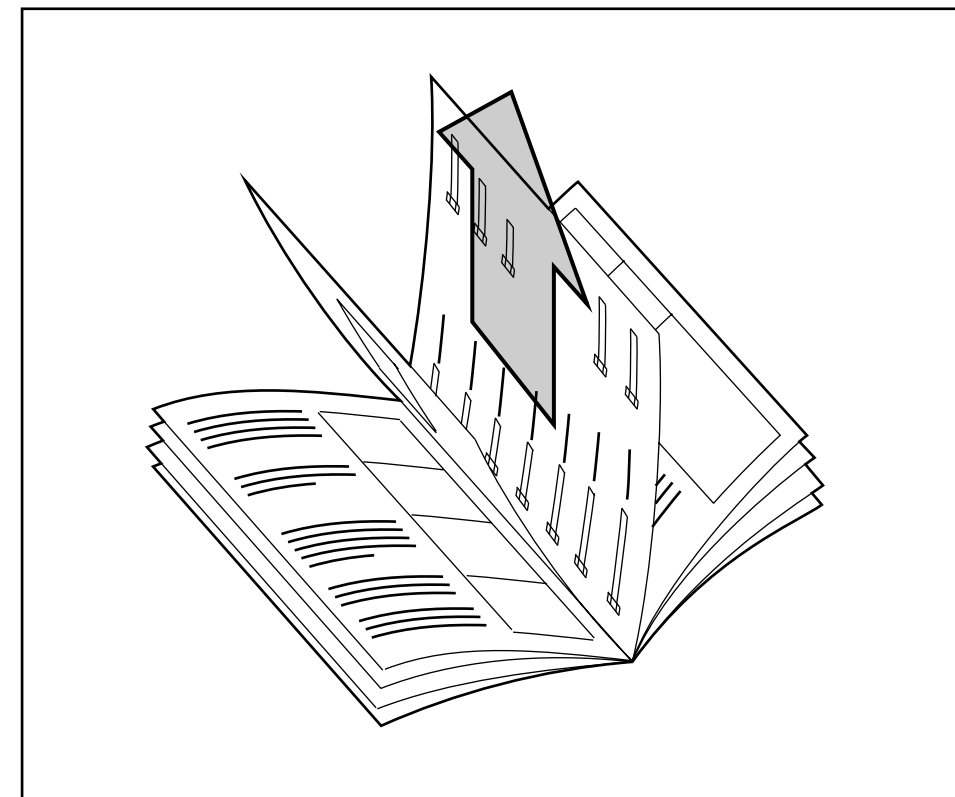

IMPORTANT: Assembly is divided into four stages: 1) frame assembly, 2) arm assembly, 3) cable assembly, and 4) seat assembly. The hardware for each stage is packaged separately. Wait until you begin each assembly stage to open that parts bag.

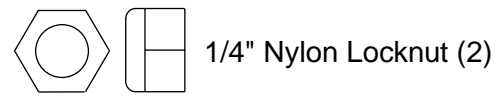

1/4" Nylon Locknut (2)

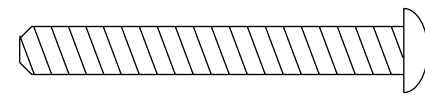

1/4" x 2" Machine Screw (24)

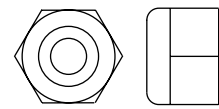

5/16" Nylon Locknut (3)

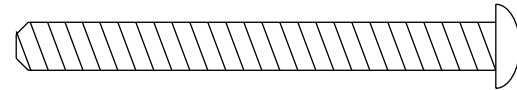

1/4" x 2 1/2" Screw (43)

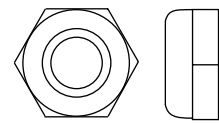

3/8" Nylon Jam Nut (92)

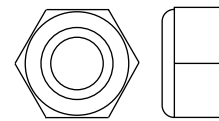

3/8" Nylon Locknut (21)

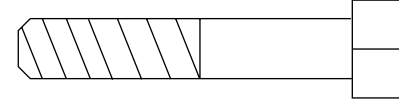

5/16" x 1 3/4" Bolt (72)

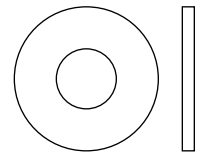

1/4" Washer (10)

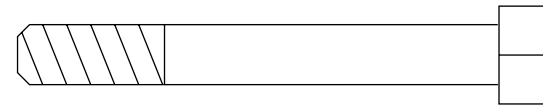

5/16" x 2 1/2" Bolt (22)

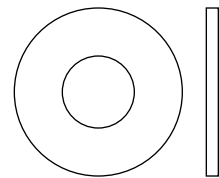

5/16" Washer (8)



5/16" x 2 3/4" Bolt (11)

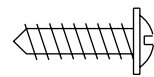

1/2" Metal Screw (77)



5/16" x 2 1/2" Carriage Bolt (1)

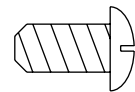

1/4" x 1/2" Screw (18)

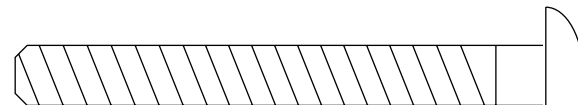

5/16" x 2 3/4" Carriage Bolt (14)

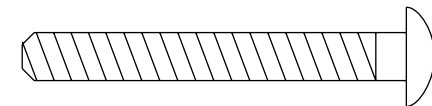

1/4" x 2" Carriage Bolt (38)

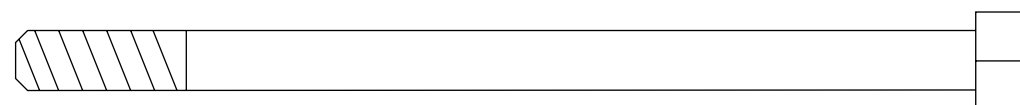

5/16" x 5" Bolt (68)

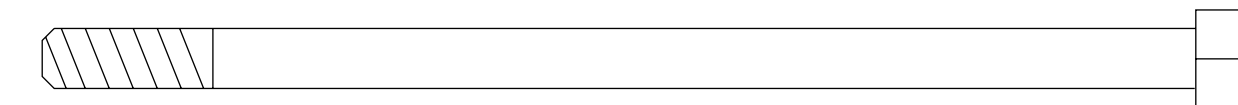

5/16" x 6" Bolt (60)

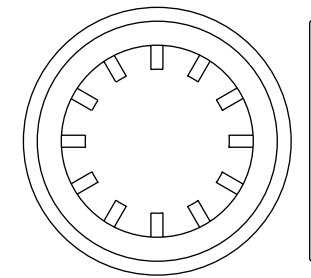

1" Retainer (69)

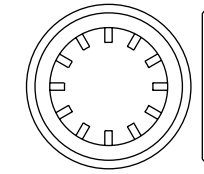

5/8" Retainer (84)

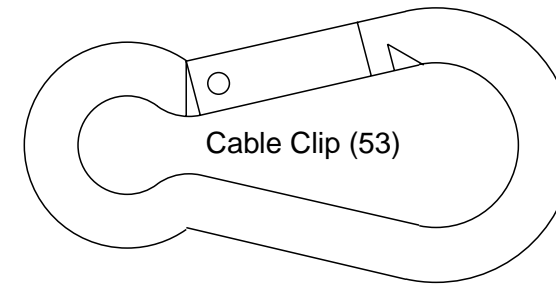

Cable Clip (53)

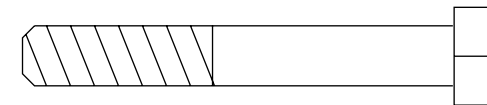

5/16" x 2 1/4" Bolt (33)

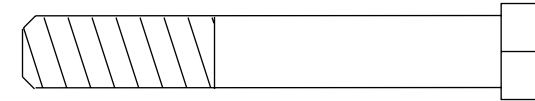

3/8" x 2 1/2" Bolt (7)

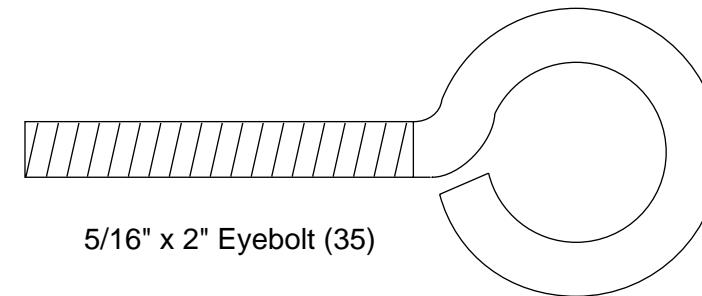

5/16" x 2" Eyebolt (35)

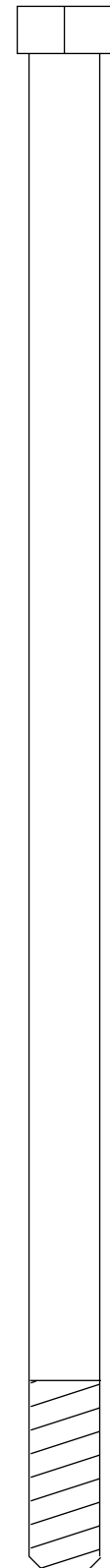

3/8" x 8" Bolt (59)

PART LIST—Model No. WEEVSY87210

R0202B

Key No.	Qty.	Description	Key No.	Qty.	Description
1	3	5/16" x 2 1/2" Carriage Bolt	48	1	Right Arm
2	3	1/4" Nylon Locknut	49	4	1" Round Inner Cap
3	18	5/16" Nylon Locknut	50	3	Long Cable Trap
4	1	Base	51	2	2" Square Outer Cap
5	1	Stabiliser	52	1	Chain
6	3	"V"-Pulley	53	2	Cable Clip
7	3	3/8" x 2 1/2" Bolt	54	1	Lat Bar
8	5	5/16" Washer	55	1	Top Frame
9	5	3/8" Washer	56	1	Rear Upright
10	6	1/4" Washer	57	1	Long "U"-Bracket
11	5	5/16" x 2 3/4" Bolt	58	1	Short Cable
12	3	3/8" x 2" Bolt	59	1	3/8" x 8" Bolt
13	1	Seat	60	1	5/16" x 6" Bolt
14	3	5/16" x 2 3/4" Carriage Bolt	61	2	1/2" x 3/4" Spacer
15	7	3 1/2" Pulley	62	2	Weight Guide
16	1	3/8" x 3 1/2" Bolt	63	1	Weight Tube
17	1	Press Frame	64	1	Weight Tube Bumper
18	2	1/4" x 1/2" Screw	65	1	1" Square Inner Cap
19	2	Weight Bumper	66	2	Cable Trap
20	1	Pulley Bracket	67	1	Small "U"-Bracket
21	11	3/8" Nylon Locknut	68	1	5/16" x 5" Bolt
22	4	5/16" x 2 1/2" Bolt	69	6	1" Retainer
23	1	Long Cable	70	4	1" Round Cover Cap
24	1	1/4" x 2" Screw	71	4	3/8" x 3 3/4" Bolt
25	6	Weight	72	1	5/16" x 1 3/4" Bolt
26	1	Weight Pin	73	1	5/8" x 9/16" Spacer
27	2	2" Square Inner Cap	74	2	1 1/4" x 2 1/2" Plastic Bushing
28	2	12 1/2" Pad Tube	75	2	1" x 7/8" Plastic Bushing
29	1	Leg Lever	76	1	Top Weight
30	4	5 1/2" Pad	77	2	1/2" Metal Screw
31	6	5" Plastic Hand Grip	78	1	Right Pedal
32	2	1 1/2" Square Inner Cap	79	1	Left Pedal
33	1	5/16" x 2 1/4" Bolt	80	2	Resistance Cylinder
34	4	3/4" Round Inner Cap	81	2	Pedal Cover
35	1	3/8" x 2" Eyebolt	82	4	1 1/2" Bushing
36	1	Seat Frame	83	4	Resistance Cylinder Bushing
37	1	Seat Plate	84	2	5/8" Retainer
38	1	1/4" x 2" Carriage Bolt	85	2	5/8" Round Cover Cap
39	1	Nylon Strap	86	2	5/8" Spacer
40	1	Seat Knob	87	1	Brace
41	1	Backrest	88	1	3 1/2" Low Pulley
42	1	Front Upright	89	6	Pulley Cover
43	2	1/4" x 2 1/2" Screw	90	1	Lock Pin
44	6	1 3/4" Square Inner Cap	91	1	Lock
45	2	10" Pad	92	2	3/8" Nylon Jam Nut
46	2	Press Arm	#	1	User's Manual
47	1	Left Arm			

REMOVE THIS PART LIST/EXPLODED DRAWING FROM THE MANUAL

SAVE THIS PART LIST/EXPLODED DRAWING FOR FUTURE REFERENCE

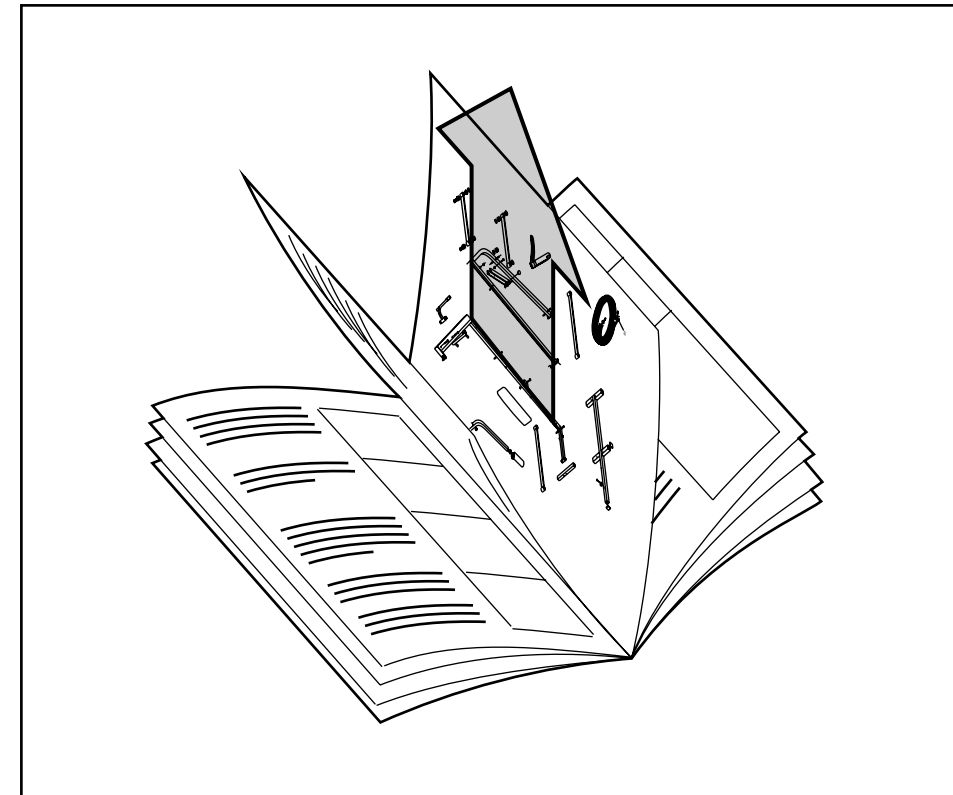

Note: "#" indicates a non-illustrated part. Specifications are subject to change without notice. See the back cover for information about ordering replacement parts.

EXPLODED DRAWING—Model No. WEEVSY87210

R0202B

