

# *Cub Cadet*<sup>®</sup>

## OPERATOR'S MANUAL

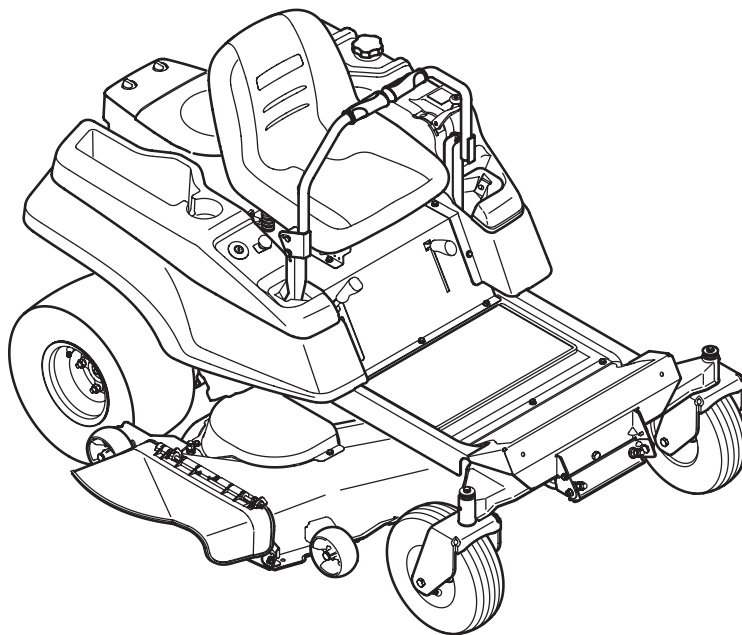

### RZT Series Tractor — Model RZT50VT

#### **⚠ WARNING**

**READ AND FOLLOW ALL SAFETY RULES AND INSTRUCTIONS IN THIS MANUAL  
BEFORE ATTEMPTING TO OPERATE THIS MACHINE.  
FAILURE TO COMPLY WITH THESE INSTRUCTIONS MAY RESULT IN PERSONAL INJURY.**

---

CUB CADET LLC, P.O. BOX 361131 CLEVELAND, OHIO 44136-0019

---

## Thank You

Thank you for purchasing an RZT series tractor manufactured by Cub Cadet LLC. It was carefully engineered to provide excellent performance when properly operated and maintained.

Please read this entire manual prior to operating the equipment. It instructs you how to safely and easily set up, operate and maintain your machine. Please be sure that you, and any other persons who will operate the machine, carefully follow the recommended safety practices at all times. Failure to do so could result in personal injury or property damage.

All information in this manual is relative to the most recent product information available at the time of printing. Review this manual frequently to familiarize yourself with the machine, its features and operation. Please be aware that this Operator's Manual may cover a range of product specifications for various

models. Characteristics and features discussed and/or illustrated in this manual may not be applicable to all models. Cub Cadet LLC reserves the right to change product specifications, designs and equipment without notice and without incurring obligation.

If you have any problems or questions concerning the machine, phone your local Cub Cadet dealer or contact us directly. Cub Cadet's Customer Support telephone numbers, website address and mailing address can be found on this page. We want to ensure your complete satisfaction at all times.

Throughout this manual, all references to *right* and *left* side of the machine are observed from the operating position.

## Table of Contents

<i>Safe Operation Practices</i> .....	<b>3</b>	<i>Service</i> .....	<b>29</b>
<i>Assembly &amp; Set-Up</i> .....	<b>9</b>	<i>Troubleshooting</i> .....	<b>36</b>
<i>Controls &amp; Features</i> .....	<b>12</b>	<i>Replacement Parts</i> .....	<b>38</b>
<i>Operation</i> .....	<b>15</b>	<i>Attachments &amp; Accessories</i> .....	<b>40</b>
<i>Maintenance &amp; Adjustment</i> .....	<b>22</b>	<i>Warranty</i> .....	<b>Back Cover</b>

## Record Product Information

Before setting up and operating your new equipment, please locate the model plate on the equipment and record the information in the provided area to the right. This information will be necessary, should you seek technical support via our web site or with your local Cub Cadet dealer. Pivot the seat assembly forward to locate the model plate on the underside of the seat pivot bracket.

### MODEL NUMBER

--	--	--	--	--	--	--	--	--	--	--	--

### SERIAL NUMBER

--	--	--	--	--	--	--	--	--	--	--	--

## Customer Support

If you have difficulty assembling this product or have any questions regarding the controls, operation, or maintenance of this machine, you can seek help from the experts. Choose from the options below:

- ◇ Visit us on the web at [www.cubcadet.com](http://www.cubcadet.com)
- ◇ Locate your nearest Cub Cadet Dealer at (877) 282-8684
- ◇ Write us at Cub Cadet LLC • P.O. Box 361131 • Cleveland, OH • 44136-0019



**WARNING!** This symbol points out important safety instructions which, if not followed, could endanger the personal safety and/or property of yourself and others. Read and follow all instructions in this manual before attempting to operate this machine. Failure to comply with these instructions may result in personal injury.

When you see this symbol. **HEED ITS WARNING!**

## CALIFORNIA PROPOSITION 65



**WARNING!** Engine Exhaust, some of its constituents, and certain vehicle components contain or emit chemicals known to State of California to cause cancer and birth defects or other reproductive harm.



**WARNING!** Battery posts, terminals, and related accessories contain lead and lead compounds, chemicals known to the State of California to cause cancer and reproductive harm. *Wash hands after handling*



**DANGER!** This machine was built to be operated according to the safe operation practices in this manual. As with any type of power equipment, carelessness or error on the part of the operator can result in serious injury. This machine is capable of amputating hands and feet and throwing objects. Failure to observe the following safety instructions could result in serious injury or death.

## General Operation

1. Read, understand, and follow all instructions on the machine and in the manual(s) before attempting to assemble and operate. Keep this manual in a safe place for future and regular reference and for ordering replacement parts.
2. Be familiar with all controls and their proper operation. Know how to stop the machine and disengage them quickly.
3. Never allow children under 14 years of age to operate this machine. Children 14 and over should read and understand the instructions and safe operation practices in this manual and on the machine and should be trained and supervised by an adult.
4. Never allow adults to operate this machine without proper instruction.
5. To help avoid blade contact or a thrown object injury, keep bystanders, helpers, children and pets at least 75 feet from the machine while it is in operation. Stop machine if anyone enters the area.
6. Thoroughly inspect the area where the equipment is to be used. Remove all stones, sticks, wire, bones, toys, and other foreign objects which could be picked up and thrown by the blade(s). Thrown objects can cause serious personal injury.
7. Plan your mowing pattern to avoid discharge of material toward roads, sidewalks, bystanders and the like. Also, avoid discharging material against a wall or obstruction which may cause discharged material to ricochet back toward the operator.
8. Always wear safety glasses or safety goggles during operation and while performing an adjustment or repair to protect your eyes. Thrown objects which ricochet can cause serious injury to the eyes.
9. Wear sturdy, rough-soled work shoes and close-fitting slacks and shirts. Loose fitting clothes and jewelry can be caught in movable parts. Never operate this machine in bare feet or sandals.
10. Be aware of the mower and attachment discharge direction and do not point it at anyone. Do not operate the mower without the discharge cover or entire grass catcher in its proper place.
11. Do not put hands or feet near rotating parts or under the cutting deck. Contact with the blade(s) can amputate hands and feet.

12. A missing or damaged discharge cover can cause blade contact or thrown object injuries.
13. Stop the blade(s) when crossing gravel drives, walks, or roads and while not cutting grass.
14. Watch for traffic when operating near or crossing roadways. This machine is not intended for use on any public roadway.
15. Do not operate the machine while under the influence of alcohol or drugs.
16. Mow only in daylight or good artificial light.
17. Never carry passengers.
18. Back up slowly. Always look down and behind before and while backing to avoid a back-over accident. Be aware and pay attention to the safety system function that stops power to the blades when driving in reverse. If not functioning properly, contact an authorized dealer for safety system inspection and repair.
19. Slow down before turning. Operate the machine smoothly. Avoid erratic operation and excessive speed.
20. Disengage blade(s), set parking brake, stop engine and wait until the blade(s) come to a complete stop before removing grass catcher, emptying grass, unclogging chute, removing any grass or debris, or making any adjustments.
21. Never leave a running machine unattended. Always turn off blade(s), place drive control levers in neutral, set parking brake, stop engine and remove key before dismounting.
22. Use extra care when loading or unloading the machine into a trailer or truck. This machine should not be driven up or down ramp(s), because the machine could tip over, causing serious personal injury. The machine must be pushed manually on ramp(s) to load or unload properly.
23. Muffler and engine become hot and can cause a burn. Do not touch.
24. Check overhead clearances carefully before driving under low hanging tree branches, wires, door openings etc., where the operator may be struck or pulled from the machine, which could result in serious injury.
25. Disengage all attachment clutches, set the parking brake to the 'ON' position and move the RH and LH drive control levers fully outward to the neutral position before attempting to start the engine.
26. Your machine is designed to cut normal residential grass of a height no more than 10". Do not attempt to mow through unusually tall, dry grass (e.g., pasture) or piles of dry leaves. Dry grass or leaves may contact the engine exhaust and/or build up on the mower deck presenting a potential fire hazard.
27. Use only accessories and attachments approved for this machine by the machine manufacturer. Read, understand and follow all instructions provided with the approved accessory or attachment.
28. Data indicates that operators, age 60 years and above, are involved in a large percentage of riding mower-related injuries. These operators should evaluate their ability to operate the riding mower safely enough to protect themselves and others from serious injury.
29. If situations occur which are not covered in this manual, use care and good judgment. Contact your customer service representative for assistance.

### Slope Operation

Slopes are a major factor related to loss of control and tip-over accidents which can result in severe injury or death. All slopes require extra caution. If you cannot back up the slope or if you feel uneasy on it, do not mow it.

For your safety, use the slope gauge included as part of this manual to measure slopes before operating this machine on a sloped or hilly area. If the slope is greater than 15 degrees as shown on the slope gauge, do not operate this machine on that area or serious injury could result.

#### Do:

1. Mow across slopes, not up and down. Exercise extreme caution when changing direction on slopes.
2. Watch for holes, ruts, bumps, rocks, or other hidden objects. Uneven terrain could overturn the machine. Tall grass can hide obstacles.
3. Use slow speed. Choose a low enough speed so that you will not have to stop while on the slope. Avoid starting or stopping on a slope. If the tires are unable to maintain traction, disengage the blades and proceed slowly and carefully straight down the slope.
4. Follow the manufacturer's recommendations for wheel weights or counterweights to improve stability.
5. Use extra care with grass catchers or other attachments. These can change the stability of the machine.
6. Keep all movement on the slopes slow and gradual. Do not make sudden changes in speed or direction. Rapid acceleration or deceleration could cause the front of the machine to lift and rapidly flip over backwards, which could cause serious injury.

#### Do Not:

1. Do not turn on slopes unless necessary; then turn slowly uphill and use extra care while turning.
2. Do not mow near drop-offs, ditches or embankments. The mower could suddenly turn over if a wheel is over the edge of a cliff, ditch, or if an edge caves in.
3. Do not try to stabilize the machine by putting your foot on the ground.
4. Do not use a grass catcher on steep slopes.
5. Do not mow on wet grass. Reduced traction could cause sliding.
6. Do not tow heavy pull behind attachments (e.g. loaded dump cart, lawn roller, etc.) on slopes greater than 5 degrees. When going down hill, the extra weight tends to push the tractor and may cause you to lose control (e.g. tractor may speed up, braking and steering ability are reduced, attachment may jack-knife and cause tractor to overturn).

## Children

1. Tragic accidents can occur if the operator is not alert to the presence of children. Children are often attracted to the machine and the mowing activity. They do not understand the dangers. Never assume that children will remain where you last saw them.
    - a. Keep children out of the mowing area and in watchful care of a responsible adult other than the operator.
    - b. Be alert and turn machine off if a child enters the area.
    - c. To avoid back-over accidents, always look behind and down for small children.
    - d. Never carry children, even with the blade(s) shut off. They may fall off and be seriously injured or interfere with safe machine operation.
    - e. Use extreme care when approaching blind corners, doorways, shrubs, trees or other objects that may block your vision of a child who may run into the path of the machine.
    - f. Keep children away from hot or running engines. They can suffer burns from a hot muffler.
    - g. Remove key when machine is unattended to prevent unauthorized operation.
  2. Never allow children under 14 years of age to operate this machine. Children 14 and over should read and understand the instructions and safe operation practices in this manual and on the machine and should be trained and supervised by an adult.
- a. When practical, remove gas-powered equipment from the truck or trailer and refuel it on the ground. If this is not possible, then refuel such equipment on a trailer with a portable container, rather than from a gasoline dispenser nozzle.
  - d. Keep the nozzle in contact with the rim of the fuel tank or container opening at all times until fueling is complete. Do not use a nozzle lock-open device.
  - e. Extinguish all cigarettes, cigars, pipes and other sources of ignition.
  - f. Never fuel machine indoors.
  - g. Never remove gas cap or add fuel while the engine is hot or running. Allow engine to cool at least two minutes before refueling.
  - h. Never over fill fuel tank. Fill tank to no more than  $\frac{1}{2}$  inch below bottom of filler neck to allow space for fuel expansion.
  - i. Replace gasoline cap and tighten securely.
  - j. If gasoline is spilled, wipe it off the engine and equipment. Move machine to another area. Wait 5 minutes before starting the engine.
  - k. To reduce fire hazards, keep machine free of grass, leaves, or other debris build-up. Clean up oil or fuel spillage and remove any fuel soaked debris.
  - l. Never store the machine or fuel container inside where there is an open flame, spark or pilot light as on a water heater, space heater, furnace, clothes dryer or other gas appliances.
  - m. Allow a machine to cool at least five minutes before storing.

## Towing

1. Tow only with a machine that has a hitch designed for towing. Do not attach towed equipment except at the hitch point.
2. Follow the manufacturer's recommendation for weight limits for towed equipment and towing on slopes.
3. Never allow children or others in or on towed equipment.
4. On slopes, the weight of the towed equipment may cause loss of traction and loss of control.
5. Travel slowly and allow extra distance to stop.
6. Do not shift to neutral and coast downhill.

## Service

### Safe Handling of Gasoline:

1. To avoid personal injury or property damage use extreme care in handling gasoline. **Gasoline is extremely flammable and the vapors are explosive.** Serious personal injury can occur when gasoline is spilled on yourself or your clothes which can ignite. Wash your skin and change clothes immediately.
  - a. Use only an approved gasoline container.
  - b. Never fill containers inside a vehicle or on a truck or trailer bed with a plastic liner. Always place containers on the ground away from your vehicle before filling.

### General Service

1. Never run an engine indoors or in a poorly ventilated area. Engine exhaust contains carbon monoxide, an odorless, and deadly gas.
2. Before cleaning, repairing, or inspecting, make certain the blade(s) and all moving parts have stopped. Disconnect the spark plug wire and ground against the engine to prevent unintended starting.
3. Periodically check to make sure the blades come to complete stop within approximately (5) five seconds after operating the blade disengagement control. If the blades do not stop within the this time frame, your machine should be serviced professionally by an authorized dealer.
4. Regularly check the safety interlock system for proper function, as described later in this manual. If the safety interlock system does not function properly, have your machine serviced professionally by an authorized dealer.

5. Check the blade(s) and engine mounting bolts at frequent intervals for proper tightness. Also, visually inspect blade(s) for damage (e.g., excessive wear, bent, cracked). Replace the blade(s) with the original equipment manufacturer's (O.E.M.) blade(s) only, listed in this manual. "Use of parts which do not meet the original equipment specifications may lead to improper performance and compromise safety!"
6. Mower blades are sharp. Wrap the blade or wear gloves, and use extra caution when servicing them.
7. Keep all nuts, bolts, and screws tight to be sure the equipment is in safe working condition.
8. Never tamper with the safety interlock system or other safety devices. Check their proper operation regularly.
9. After striking a foreign object, stop the engine, disconnect the spark plug wire(s) and ground against the engine. Thoroughly inspect the machine for any damage. Repair the damage before starting and operating.
10. Never attempt to make adjustments or repairs to the machine while the engine is running.
11. Grass catcher components and the discharge cover are subject to wear and damage which could expose moving parts or allow objects to be thrown. For safety protection, frequently check components and replace immediately with original equipment manufacturer's (O.E.M.) parts only, listed in this manual. "Use of parts which do not meet the original equipment specifications may lead to improper performance and compromise safety!"
12. Do not change the engine governor settings or over-speed the engine. The governor controls the maximum safe operating speed of the engine.
13. Maintain or replace safety and instruction labels, as necessary.
14. Observe proper disposal laws and regulations for gas, oil, etc. to protect the environment.
15. According to the Consumer Products Safety Commission (CPSC) and the U.S. Environmental Protection Agency (EPA), this product has an *Average Useful Life* of seven (7) years, or 270 hours of operation. At the end of the *Average Useful Life* have the machine inspected annually by an authorized service dealer to ensure that all mechanical and safety systems are working properly and not worn excessively. Failure to do so can result in accidents, injuries or death.

## Do not modify engine

To avoid serious injury or death, do not modify engine in any way. Tampering with the governor setting can lead to a runaway engine and cause it to operate at unsafe speeds. Never tamper with factory setting of engine governor.

## Notice Regarding Emissions

Engines which are certified to comply with California and federal EPA emission regulations for SORE (Small Off Road Equipment) are certified to operate on regular unleaded gasoline, and may include the following emission control systems: Engine Modification (EM) and Three Way Catalyst (TWC) if so equipped.

## Spark Arrestor









**WARNING!** This machine is equipped with an internal combustion engine and should not be used on or near any unimproved forest-covered, brush-covered or grass-covered land unless the engine's exhaust system is equipped with a spark arrester meeting applicable local or state laws (if any).

If a spark arrester is used, it should be maintained in effective working order by the operator. In the State of California the above is required by law (Section 4442 of the California Public Resources Code). Other states may have similar laws. Federal laws apply on federal lands.

A spark arrester for the muffler is available through your nearest engine authorized service dealer or contact the service department, P.O. Box 361131 Cleveland, Ohio 44136-0019.

## Safety Symbols

This page depicts and describes safety symbols that may appear on this product. Read, understand, and follow all instructions on the machine before attempting to assemble and operate.

Symbol	Description
	<b>READ THE OPERATOR'S MANUAL(S)</b> Read, understand, and follow all instructions in the manual(s) before attempting to assemble and operate
	<b>WARNING— ROTATING BLADES</b> Do not put hands or feet near rotating parts or under the cutting deck. Contact with the blade(s) can amputate hands and feet.
	<b>WARNING—THROWN OBJECTS</b> This machine may pick up and throw and objects which can cause serious personal injury.
	<b>WARNING—THROWN OBJECTS</b> This machine may pick up and throw and objects which can cause serious personal injury.
	<b>BYSTANDERS</b> Keep bystanders, helpers, children and pets at least 75 feet from the machine while it is in operation.
	<b>WARNING— SLOPE OPERATION</b> Do not operate this machine on a slope greater than 15 degrees.
	<b>DANGER — ROTATING BLADES</b> To reduce the risk of injury, keep hands and feet away. Do not operate unless discharge cover or grass catcher is in its proper place. If damaged, replace immediately.



**WARNING!** Your Responsibility—Restrict the use of this power machine to persons who read, understand and follow the warnings and instructions in this manual and on the machine.

**SAVE THESE INSTRUCTIONS!**

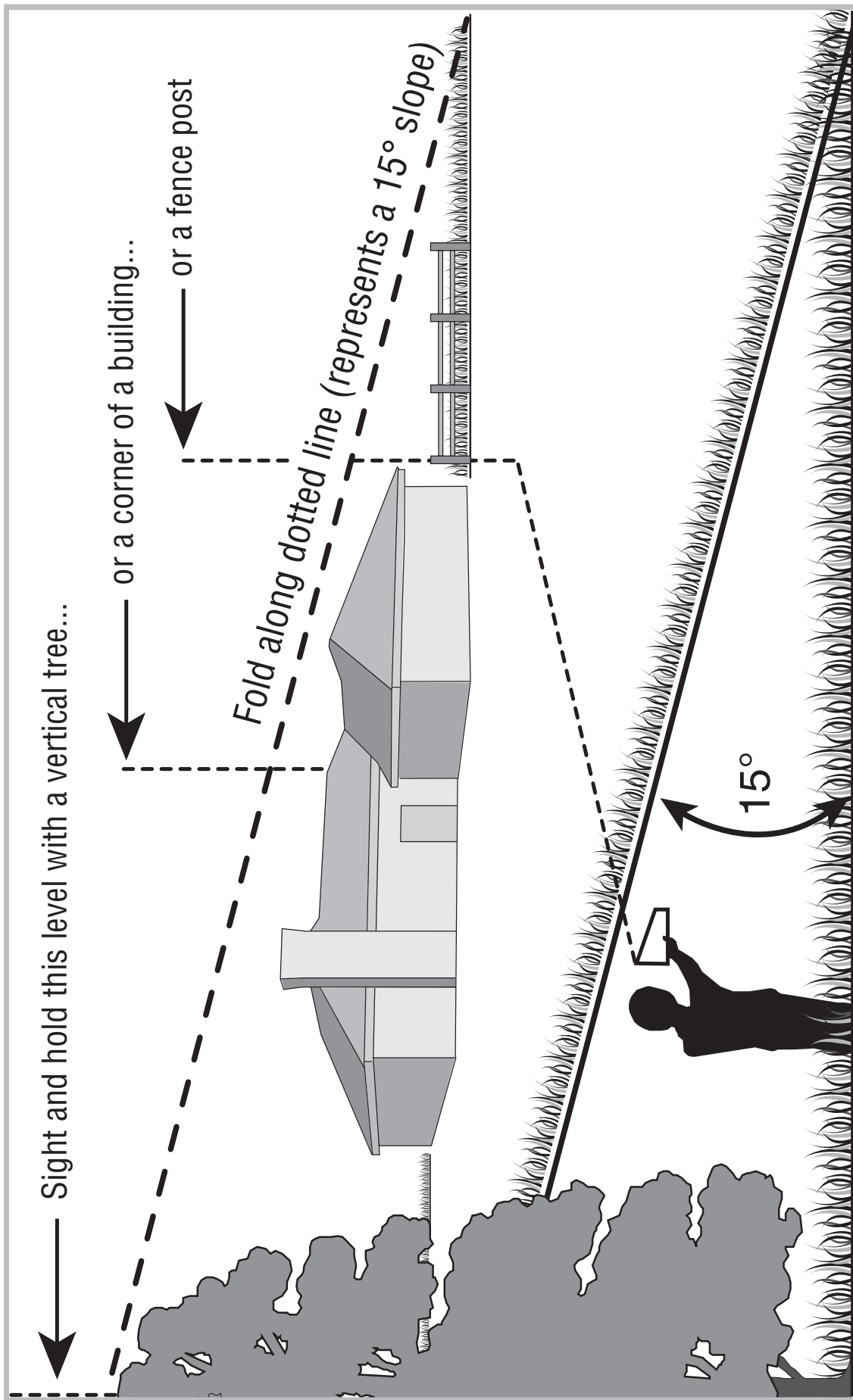

**Use this page as a guide to determine slopes where you may not operate safely.**



**WARNING!** Do not operate your lawn mower on such slopes. Do not mow on inclines with a slope in excess of 15 degrees (a rise of approximately 2-1/2 feet every 10 feet). A riding mower could overturn and cause serious injury. Operate riding mowers up and down slopes, never across the face of slopes.

OPERATE RZT zero turn tractors across the face of slopes rather than up and down. Begin with the first pass across the bottom of the slope and turn uphill at the end of each pass whenever possible.



## Contents of Crate

- One Lawn Tractor
- One Oil Drain Tube
- One Deck Wash Hose Coupler
- One RZT Tractor Operator's Manual
- One Briggs & Stratton Engine Operator's Manual

## Tractor Preparation

Remove the upper crating material from the shipping pallet, and cut any bands or tie straps securing the tractor to the pallet.

Use the lift handle to raise the deck to its highest position. Engage the transmission bypass rods on each side of the tractor; then carefully roll the tractor off the shipping pallet. The transmission bypass rods (one for each the RH and LH transmission) are located beneath the frame platform, just inside each rear wheel. Disengage the bypass rods. See Fig. 3-1.

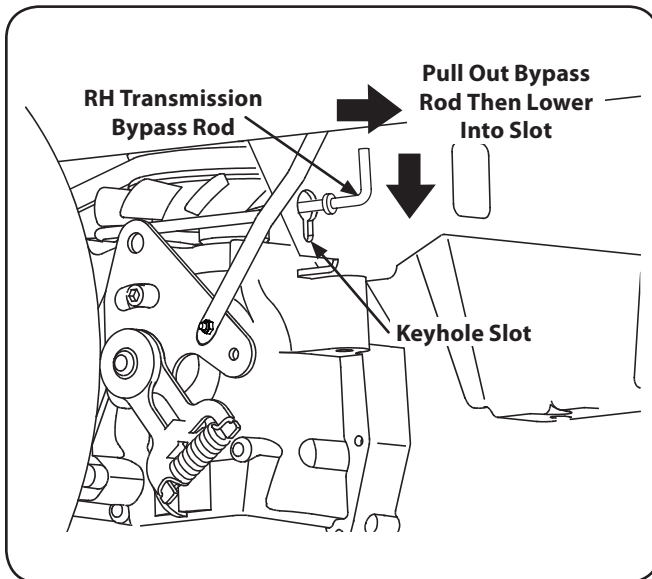

Figure 3-1

Remove the deck wash system nozzle adapter and oil drain tube from the manual bag and store for future use.

## Install Operator's Seat

To install the seat proceed as follows:

**NOTE:** The seat is shipped with the seat switch and seat pan attached.

1. Cut any straps securing the seat assembly and the drive control levers to the tractor. Remove any packing material.

**NOTE:** Be careful not to cut the wiring harness connecting the seat and the seat switch.

2. Remove the two shoulder bolts and lock nuts in the seat pan as shown in Fig. 3-2.

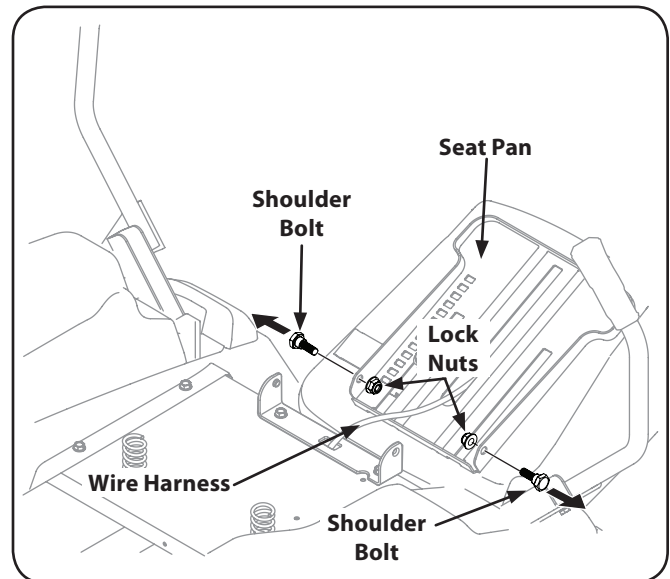

Figure 3-2

3. Rotate the seat into position and secure the seat into place with the previously removed shoulder bolts and lock nuts. Be careful not to crimp or damage the wire harness while installing the seat. See Fig. 3-3.

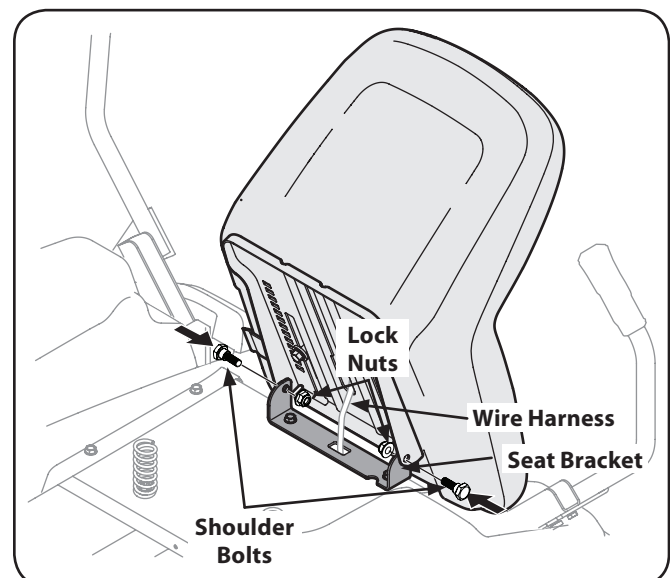

Figure 3-3

## Position Drive Control levers

The drive control levers of the tractor are lowered for shipping purposes. The flange lock nuts, hex screws, and flat washers that normally secure the control levers in their operating position are unfastened and installed in the slotted holes of the control levers for shipment. The control levers must be repositioned to operate the tractor. To reposition the control levers for operation, proceed as follows:

1. Remove the hex screw, flat washer, and flange lock nut from the slot of one of the drive control levers.
2. Lift and swing that control lever upward until the slotted hole in the lever bracket aligns with one of the holes in the pivot bracket. See Fig. 3-4.

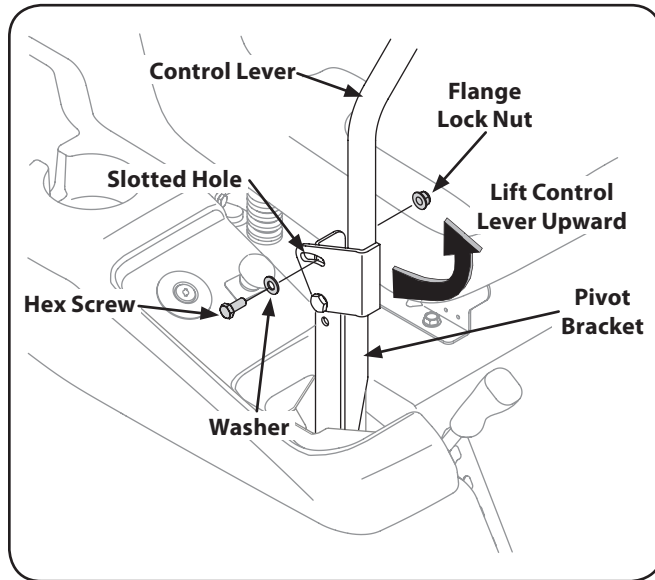

Figure 3-4

3. Slide the flat washer onto the hex screw. From the outside, insert the hex screw with washer through the control lever slot and the hole of the pivot bracket. Secure with the flange lock nut. See Fig. 3-4.
4. Note the relative position of the control lever to the pivot bracket, then repeat the previous steps to reposition the other control lever in approximately the same position.
5. Refer to "Adjusting the Drive Control Levers" in the Maintenance & Adjustments for instructions on the final adjustment of the levers.

## Connecting the Battery Cables



### CALIFORNIA PROPOSITION 65 WARNING!

Battery posts, terminals, and related accessories contain lead and lead compounds, chemicals known to the State of California to cause cancer and reproductive harm. Wash hands after handling.



**CAUTION:** When attaching battery cables, always connect the POSITIVE (Red) wire to its terminal first, followed by the NEGATIVE (Black) wire.

For shipping reasons, both battery cables on your equipment may have been left disconnected from the terminals at the factory. To connect the battery cables, proceed as follows:

**NOTE:** The positive battery terminal is marked Pos. (+). The negative battery terminal is marked Neg. (-).

**NOTE:** If the positive battery cable is already attached, skip ahead to step 2.

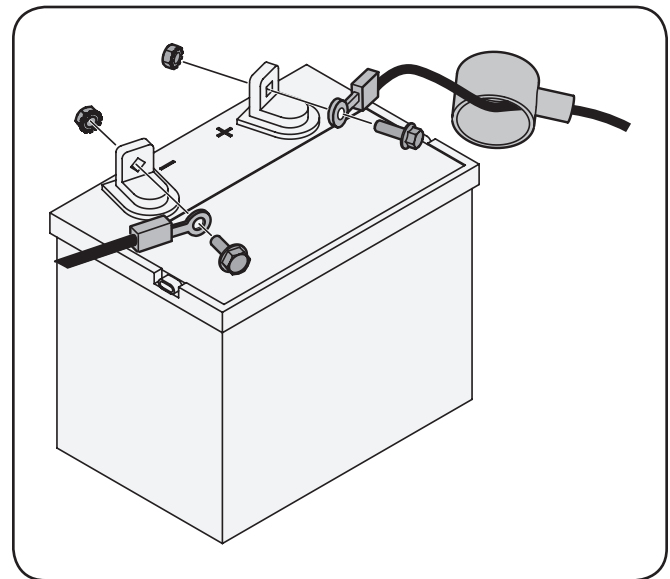

Figure 3-5

1. Remove the plastic cover, if present, from the positive battery terminal and attach the red cable to the positive battery terminal (+) with the bolt and hex nut. See Fig. 3-5.
2. Remove the plastic cover, if present, from the negative battery terminal and attach the black cable to the negative battery terminal (-) with the bolt and hex nut. See Fig. 3-5.
3. Position the red rubber boot over the positive battery terminal to help protect it from corrosion.

**NOTE:** If the battery is put into service after the date shown on top/side of battery, charge the battery as instructed in the Maintenance section your Operator's Manual prior to operating the tractor.

## Lower Deck Discharge Chute Deflector



**WARNING!** Never operate the mower deck without the chute deflector installed and in the down position.

Check the mower deck for a shipping brace (with tag) that may be holding the chute deflector upward for shipment. If a brace is present, it must be removed before operating the tractor. Holding the chute deflector fully upward, remove the shipping brace by grasping it and rotating it clockwise. Lower the chute deflector. See Fig. 3-6.

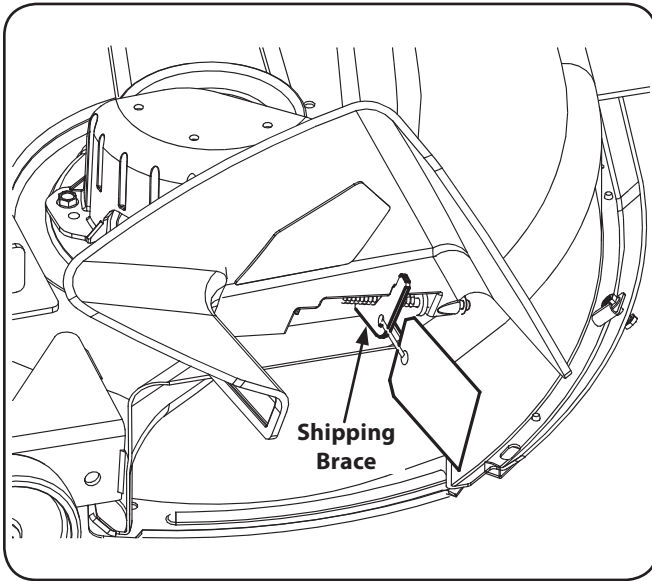

Figure 3-6

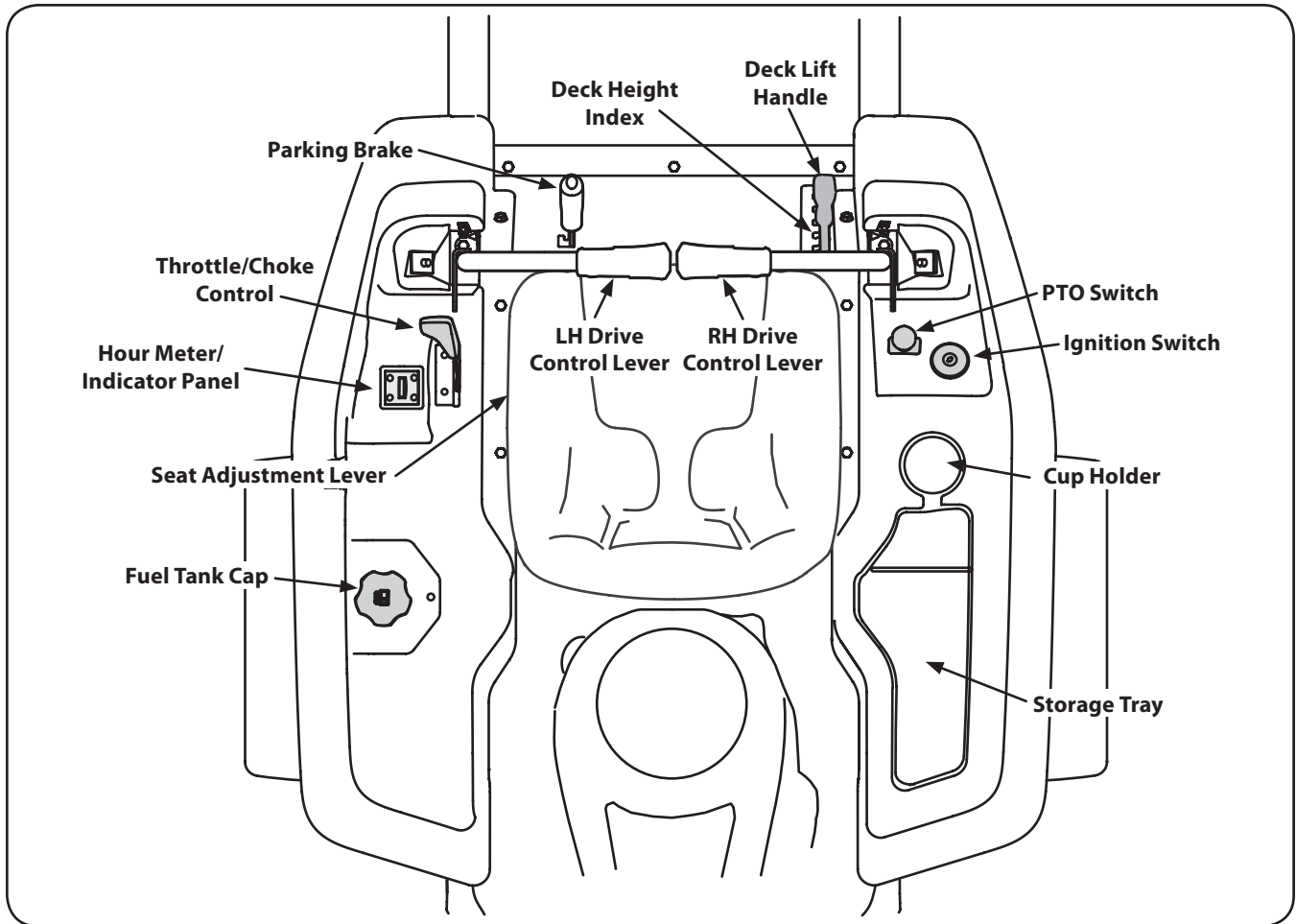

Figure 4-1

**NOTE:** References to LEFT, RIGHT, FRONT, and REAR indicate that position on the tractor when facing forward while seated in the operator's seat.

## Deck Height Index

The deck height index consists of six index notches located on the front/right of the seat box frame. Each notch corresponds to a 1/2" change in the deck height position ranging from 1-1/2" at the lowest notch to 4" at the highest notch.

## Deck Lift Handle

The deck lift handle is located on the front/right of the seat box frame, and is used to raise and lower the mower deck.

Pull the handle to the left out of the index notch and push downward to lower the deck, or pull upward to raise the deck. When the desired height is attained, move the lift handle to the right until fully in the index notch.



## RH and LH Drive Control Levers

The RH and LH control levers are located on each side of the operator's seat. These hinged levers pivot outward to open space to permit the operator to either sit in the tractor seat, or to dismount the tractor. The levers must be fully opened out and in the neutral position to start the tractor engine.

Each lever controls the respective RH or LH transmission. Consequently, these levers control all of the movements of the tractor. Driving and steering utilizing these control levers is quite different from conventional tractors, and will take some practice to master. Refer to Operation for instructions on using the control levers.

## Ignition Switch

The ignition switch is located on the RH console to the right of the operator's seat. The ignition switch has three positions as follows:

OFF - The engine and electrical system is turned off.

ON - The tractor electrical system is energized.

START - The starter motor will turn over the engine. Release the key immediately when the engine starts

**NOTE:** To prevent accidental starting and/or battery discharge, remove the key from the ignition switch when the tractor is not in use.

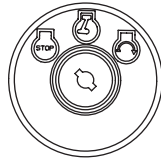

## Power Take-Off (PTO) Switch

The PTO switch is located on the RH console to the right of the operator's seat.

The PTO switch operates the electric PTO clutch mounted on the bottom of the engine crankshaft. Pull the switch knob upward to engage the PTO clutch, or push the knob downward to disengage the clutch.

The PTO switch must be in the "disengaged" position when starting the engine.

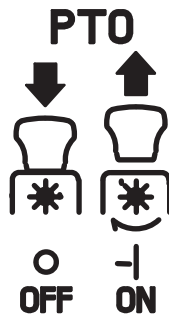

## Transmission Bypass Rods (Not Visible)

The transmission bypass rods (one for each the RH and LH transmission) are located beneath the frame platform, just inside each rear wheel.

When engaged, the two rods open a bypass within the hydrostatic transmissions, which allows the tractor to be pushed short distances by hand. Refer to Maintenance & Adjustments for instructions on using the bypass feature.



**CAUTION:** Never tow your tractor. Towing the tractor with the rear wheels on the ground may cause severe damage to the transmissions.

## Cup Holder

The cup holder is located toward the rear of the RH console to the right of the operator's seat.

## Storage Tray

The storage tray is located at the rear of the RH console.

## Seat Adjustment Lever (Not Seen)

The seat adjustment lever is located below the front/left of the seat. The lever allows for adjustment of the fore to aft position of the operator's seat. Refer to Maintenance & Adjustments for instructions on adjusting the seat position.

## Fuel Tank Cap

The fuel tank cap is located near the middle of the LH console. Turn the fill cap approximately ¼ turn and pull upward to remove. The fuel cap is tethered to the tractor to prevent its loss.

Do not attempt to remove the cap from the tractor.

Push the cap downward on the fuel tank fill neck and turn approximately ¼ turn clockwise to tighten. Always re-install the fuel cap tightly onto the fuel tank after removing.



**WARNING!** Never fill the fuel tank when the engine is running. If the engine is hot from recently running, allow to cool for several minutes before refueling. Highly flammable gasoline could splash onto the engine and cause a fire.

## Hour Meter/Indicator Panel

The hour meter/indicator panel is located on the LH console to the left of the operator's seat.

### Hour Meter Features

The hour meter records the hours that the tractor has been operated in the digital display (tenths of an hour - right most digit).

**NOTE:** The hour meter is activated whenever the ignition switch is turned to the "ON" position. Keep a record of the actual hours of operation to assure all maintenance procedures are completed according to the instructions in this manual and the engine manual.

When key is turned to the "ON" position, the battery indicator light briefly illuminates and the battery voltage is briefly displayed. The display then changes to the accumulated hours.

The Indicator Monitor will also remind the operator of maintenance intervals for changing the engine oil. The LCD will alternately flash, "CHG"; "OIL" and the recorded hours for five minutes after every 50 hours of recorded operation. The maintenance interval lasts for two hours (from 50-52, 100-102, 150-152, etc.). The LCD will flash as described for five minutes every time the tractor's engine is started during this maintenance interval. Follow the oil change intervals provided in the engine manual.

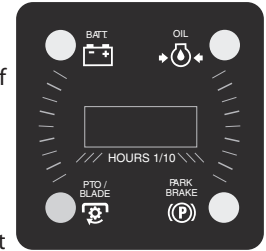

## Indicator Panel Features

### Battery Indicator

Illuminates and the battery voltage is displayed briefly when the ignition switch is turned to the "ON" position.

Illuminates to indicate the battery voltage has dropped below 11.5 (+0.5/-1.0) volts. The battery voltage is also displayed on the hour meter. If this indicator and display come on during operation, check the battery and charging system for possible causes and/or contact your Cub Cadet dealer.

### Oil Pressure Indicator

This warning lamp indicates low engine oil pressure. If the indicator comes on while the engine is running, stop the engine immediately and check for possible causes. Do not run the engine while this indicator is illuminated. Contact your Cub Cadet dealer to have the tractor and engine inspected.

**NOTE:** The oil pressure indicator may illuminate when the ignition switch is in the ON position, but should turn off when the engine is started.

### PTO Engaged Indicator

This indicator illuminates when the PTO switch is pulled upward in the "ENGAGED" position and the ignition switch is turned to the "START" position. Check this indicator if the engine will not crank with the ignition switch in the "START" position. If necessary, move the PTO switch to the "DISENGAGED" position.

### Parking Brake Engaged Indicator

This indicator illuminates when the parking brake is in the DISENGAGED position and the ignition switch is turned to the "START" position. Check this indicator if the engine will not crank with the ignition switch in the "START" position. If necessary, move the parking brake to the ENGAGED position.

This indicator also illuminates when the ignition switch is turned to the "START" position and the RH and/or LH drive control levers are in a position other than the fully out in neutral position. Move the control levers fully outward.

## Throttle/Choke Control

The throttle/choke control is located on the LH console to the left of the operator's seat. When set in a given position, a uniform engine speed will be maintained.

- Push the throttle/choke control handle forward to increase the engine speed. The tractor is designed to operate with the throttle/choke control in the fast position (full throttle) when the tractor is being driven and the mower deck is engaged.
- Pull the throttle/choke control handle rearward to decrease the engine speed.
- When starting the engine, push the control handle fully forward into the "CHOKE" position.
- After starting and warming the engine, move the control handle rearward until you feel it move past the choke detent.



## Parking Brake Engagement Lever

The parking brake engagement lever is located on the front/left of the seat box frame, and is used to engage the parking brake.

Pull the lever fully upward and to the left; then lower into the short "J" slot to engage the brake.

Pull the lever up out of the "J" slot and to the right; then lower completely to disengage the parking brake.

**NOTE:** If the LH and RH drive control levers are not fully opened out in the neutral position when engaging the parking brake, the engine will stop. The parking brake must be placed in the engaged position when starting the tractor engine.

## Transmission Oil Expansion Reservoir

The transmission oil expansion reservoir is connected by hoses to the RH and LH transmission assemblies, and is located beneath the seat box. The function of the reservoir is to hold the natural expansion of transmission oil that occurs as the transmission warms up during operation. DO NOT FILL THE RESERVOIR.

Under normal operating conditions, no oil should be added to the reservoir. The COLD oil level should be no higher than approximately 1/4" (the "Full Cold" mark) above the bottom of the reservoir.

**NOTE:** Prior to the initial operation of the tractor, the oil level in the reservoir may be slightly higher than the maximum due to air in the oil lines. Operation of the tractor will eventually purge the air from the lines and the oil level will settle to the maximum.



## General Safety

- **RECEIVE INSTRUCTION** — Entirely read this operator's manual. Learn to operate this machine SAFELY. Do not risk INJURY or DEATH. Allow only those who have become competent in its usage to operate this tractor.
- Before starting the engine or beginning operation, be familiar with the controls. The operator should be in the operator's seat. The PTO switch must be in the disengaged position, the parking brake engaged, and the RH and LH drive control levers moved fully outward in the neutral position.
- Keep all shields in place. Keep away from moving parts.
- **NO RIDERS!** Keep all people and pets a safe distance away. Look behind and down to both sides of the tractor before and while backing up.
- **DO NOT** direct the mower discharge at people.
- Avoid slopes where possible. Never operate on slopes greater than 15°. Slopes with a greater incline present dangerous operating conditions. Tractors can be rolled over.
- Before leaving the operator's seat: Shut off the PTO, move the RH and LH drive control levers fully outward in the neutral position, engage the parking brake, shut off the engine and remove the ignition key. Wait for all movement to stop before servicing or cleaning.
- Operate the drive control levers smoothly and avoid any sudden movements of the levers when starting and stopping. Keep a firm grip on the control levers.
- Be careful when operating near roadways. Stop the tractor motion and wait for vehicles to pass before operating along the road.
- Do not operate the tractor with the mower deck removed. Removal of the deck will change the balance of the tractor, and could contribute to a tractor rollover.
- Avoid operation on traction surfaces that are unstable; use extreme caution if the surface is slippery.
- Slow down before turning and come to a complete stop before any zero turn maneuver.
- Do not stop the tractor or park the tractor over combustible materials such as dry grass, leaves, debris, etc.
- Do not fill the fuel tank when the engine is running or while the engine is hot. Allow the engine several minutes to cool before refueling. Tighten the fuel cap securely.

## Before Operating Your Tractor

- Before you operate the tractor, study this manual carefully to familiarize yourself with the operation of all the instruments and controls. It has been prepared to help you operate and maintain your tractor efficiently.
- This engine is certified to operate only on clean, fresh, unleaded regular gasoline. For best results, fill the fuel tank with only clean, fresh, unleaded gasoline with a pump sticker octane rating of 87 or higher.
- Unleaded gasoline is recommended because it leaves less combustion chamber deposits and reduces harmful exhaust emissions. Leaded gasoline is not recommended and must not be used where exhaust emissions are regulated.
 

**NOTE:** Purchase gasoline in small quantities. Do not use gasoline left over from the previous season, to minimize gum deposits in the fuel system.
- Gasohol (up to 10% ethyl alcohol, 90% unleaded gasoline by volume) is an approved fuel. Other gasoline/alcohol blends are not approved.
- Methyl Tertiary Butyl Ether (MTBE) and unleaded gasoline blends (up to a maximum of 15% MTBE by volume) are approved fuels. Other gasoline/ether blends are not approved.
- Check the engine oil level.
- Clean the air cleaner element if necessary.
- Check the tire inflation pressures.
- Adjust the seat for operator's maximum comfort, visibility and for maintaining complete control of the tractor.

## Safety Interlock System

This tractor is equipped with a safety interlock system for the protection of the operator. If the interlock system should ever malfunction, do not operate the tractor. Contact your authorized Cub Cadet Dealer.

- The safety interlock system prevents the engine from cranking or starting unless the RH and LH drive control levers are moved fully outward in the neutral position, the parking brake is engaged, and the PTO is disengaged.
- To avoid sudden movement when disengaging the parking brake, the safety interlock system will shut off the engine if the RH and/or LH drive control levers are moved to a position other than the fully out in the neutral position when the parking brake is engaged.
- The safety interlock system will shut off the engine if the operator leaves the seat before engaging the parking brake.

- The safety interlock system will shut off the engine if the operator leaves the seat with the PTO engaged, regardless of whether the parking brake is engaged.

**NOTE:** The PTO switch must be moved to the "OFF" position to restart the engine.

- The safety interlock system will shut off the PTO and the mower blades will stop if both drive control levers are moved into the reverse position. The PTO will re-engage when one or both of the levers are moved back to the neutral or forward position.

## Starting the Engine



**WARNING!** This tractor is equipped with a safety interlock system designed for the protection of the operator. Do not operate the tractor if any part of the interlock system is malfunctioning. Periodically check the functions of the interlock system for proper operation.



**WARNING!** For personal safety, the operator must be sitting in the tractor seat when starting the engine.

- Operator must be sitting in the tractor seat.
- Engage the parking brake. Refer to Fig. 5-1.

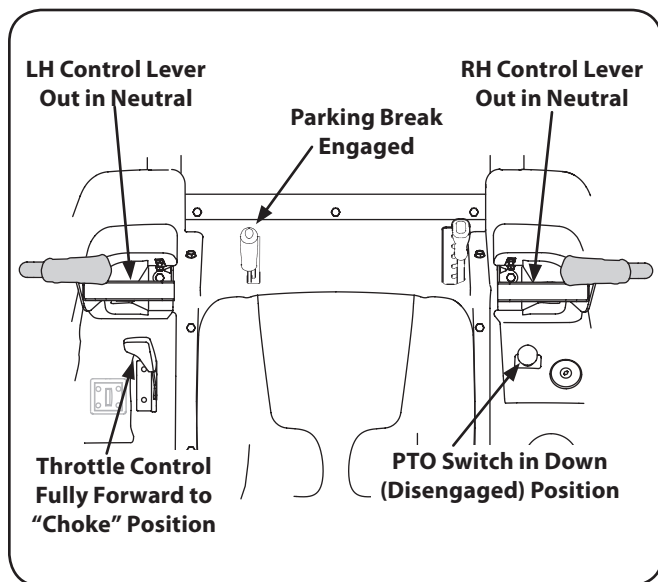

Figure 5-1

- Make certain the PTO switch is in the disengaged (down) position. Refer to Fig. 5-1.
  - Move the throttle/choke control into the full choke position.
- NOTE:** If the engine is warmed up, it may not be necessary to place the throttle/choke control in the choke position.

- Turn the ignition key clockwise to the "START" position and release it as soon as the engine starts; however, do not crank the engine continuously for more than 5 seconds at a time. If the engine does not start within this time, turn the key to "OFF" and wait at least 15 seconds to allow the engine's starter motor to cool. Try again after waiting. If after a few attempts the engine fails to start, do not keep trying to start it with the choke closed as this will cause flooding and make starting more difficult.
- As the engine warms up, gradually pull the throttle/choke control lever rearward past the choke detent position. Do not use the choke position to enrich the fuel mixture, except as necessary to start the engine.
- Allow the engine to run for a few minutes at mid throttle before putting the engine under load.
- Observe the hour meter / indicator panel. If the battery indicator light or oil pressure light come on, immediately stop the engine. Have the tractor inspected by your Cub Cadet dealer.

## Cold Weather Starting

When starting the engine at temperatures near or below freezing, ensure the correct viscosity motor oil is used in the engine and the battery is fully charged. Start the engine as follows:

- Be sure the battery is in good condition. A warm battery has much more starting capacity than a cold battery.
- Use fresh winter grade fuel. Winter grade gasoline has higher volatility to improve starting. Do not use gasoline left over from summer.
- Follow the previous instruction for Starting the Engine.

## Using Jumper Cables To Start Engine



**WARNING!** Batteries contain sulfuric acid and produce explosive gasses. Make certain the area is well ventilated, wear gloves and eye protection, and avoid sparks or flames near the battery.

If the battery charge is not sufficient to crank the engine, recharge the battery. If a battery charger is unavailable and the tractor must be started, the aid of a booster battery will be necessary. Connect the booster battery as follows:

- Connect the end of one cable to the disabled tractor battery's positive terminal; then connect the other end of that cable to the booster battery's positive terminal.
- Connect one end of the other cable to the booster battery's negative terminal; then connect the other end of that cable to the frame of the disabled tractor, as far from the battery as possible.
- Start the disabled tractor following the normal starting instructions previously provided; then disconnect the jumper cables in the exact reverse order of their connection.
- Have the tractor's electrical system checked and repaired as soon as possible to eliminate the need for jump starting.



## Stopping the Engine

1. Place the PTO switch in the "OFF" position.
2. Move the RH and LH drive control levers fully outward in the neutral position.
3. Engage the parking brake.
4. Move the throttle/choke control to midway between the SLOW and FAST positions.
5. Turn the ignition key to the "OFF" position and remove the key from the ignition switch.

**NOTE:** Always remove the key from the ignition switch to prevent accidental starting or battery discharge if the equipment is left unattended.

## Practice Operation (Initial Use)

Operating a zero-turn tractor is not like operating a conventional type riding tractor. Although and because a zero turn tractor is more maneuverable, getting used to operating the control levers takes some practice.

We strongly recommend that you locate a reasonably large, level and open "practice area" where there are no obstructions, pedestrians, or animals. You should practice operating the tractor for a minimum of 30 minutes.

Carefully move (or have moved) the tractor to the practice area. When performing the practice session, the PTO should not be engaged. While practicing, operate the tractor at approximately  $\frac{1}{2}$ - $\frac{3}{4}$  throttle and at less than full speed in both forward and reverse.

Carefully practice maneuvering the tractor using the instructions in the following section "Driving the Tractor." Practice until you are confident that you can safely operate the tractor.

## Driving the Tractor



**WARNING!** Avoid sudden starts, excessive speed and sudden stops.

1. Adjust the operator's seat to the most comfortable position that allows you to operate the controls. See seat adjustment in the Maintenance & Adjustments section.
2. Release the parking brake.

3. Move the RH and LH drive control levers inward in the neutral position. Refer to Figure 5-2.

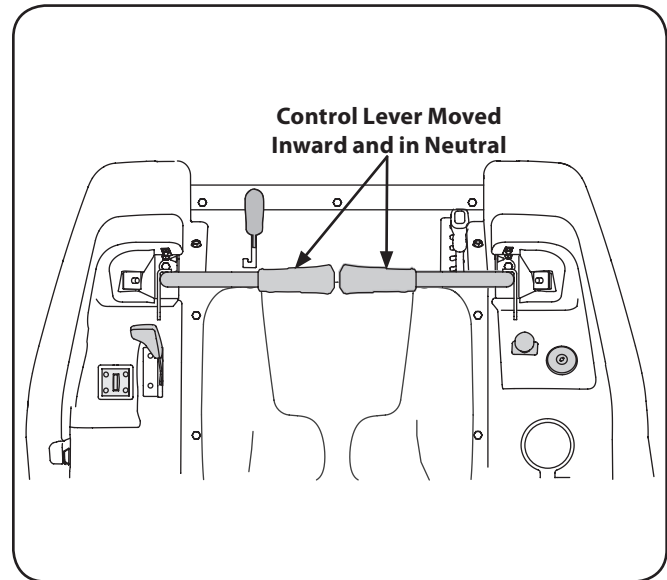

**Figure 5-2**

**NOTE:** If the control levers are not even in the neutral position, refer to Maintenance & Adjustments for instructions to adjust the levers so that they are even.

4. Move the throttle/choke control lever forward to the full throttle position (3300-3500 RPM). **NOTE:** Although the tractor's engine is designed to run at full throttle, when performing a practice session the tractor must be operated at less than full throttle (approximately 2500-3000 RPM). This only applies to practice.



**WARNING!** Always maintain a firm grip on the control levers. DO NOT release the control levers to slow or stop the tractor; move levers to neutral position using your hands.

5. To drive the tractor, firmly grasp the respective drive control levers with your right and left hands and continue with Driving the Tractor Forward on the following page.

## Driving the Tractor Forward



**WARNING!** Keep all movement of the drive control levers slow and smooth. Abrupt movement of the control levers can affect the stability of the tractor and could cause the tractor to flip over, which may result in serious injury or death to the operator.

1. Slowly and evenly move both drive control levers forward. The tractor will start to move forward. See Fig. 5-3.

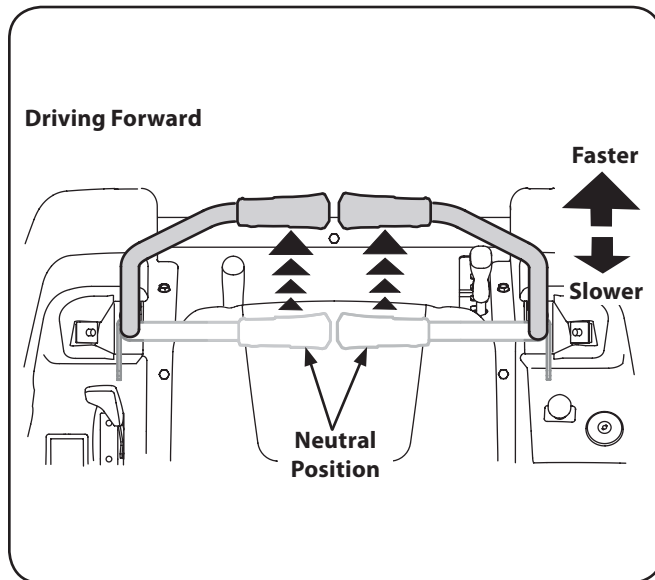

Figure 5-3

2. As the control levers are pushed farther forward the speed of the tractor will increase.
3. To slow the tractor move the controls lever rearward to attain the desired speed, or move the levers to the neutral position to stop the tractor.



**WARNING!** Always maintain your grasp on the drive control levers. Do not release the levers to slow the tractor or to return to neutral.

## Turning the Tractor While Driving Forward



**WARNING!** When reversing the direction of travel, we recommend performing gradual 'U' turns where possible. Sharper turns increase the possibility of turf defacement, and could affect control of the tractor. ALWAYS slow the tractor before making sharp turns.

To turn the tractor while driving forward, move the control levers as necessary so that one lever is rearward of the other. The tractor will turn in the direction of the rearward control lever.

1. To turn to the left, move the left drive control lever rearward of the right lever. See Fig. 5-4.

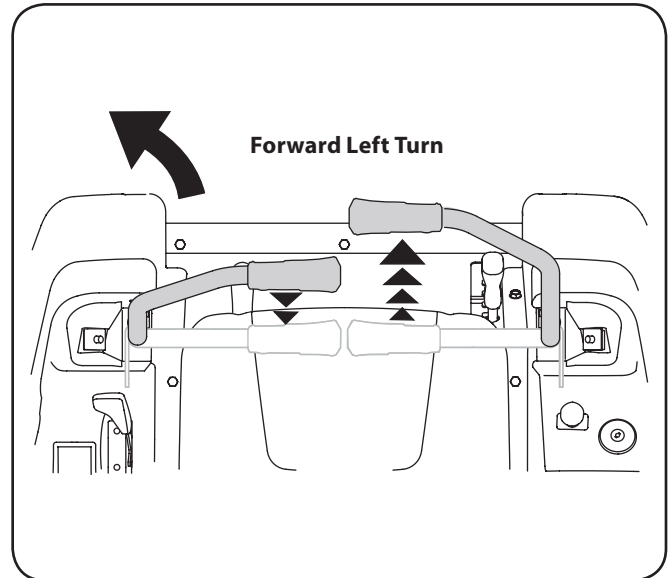

Figure 5-4

2. To turn to the right, move the right drive control lever rearward of the left lever. See Fig. 5-5.

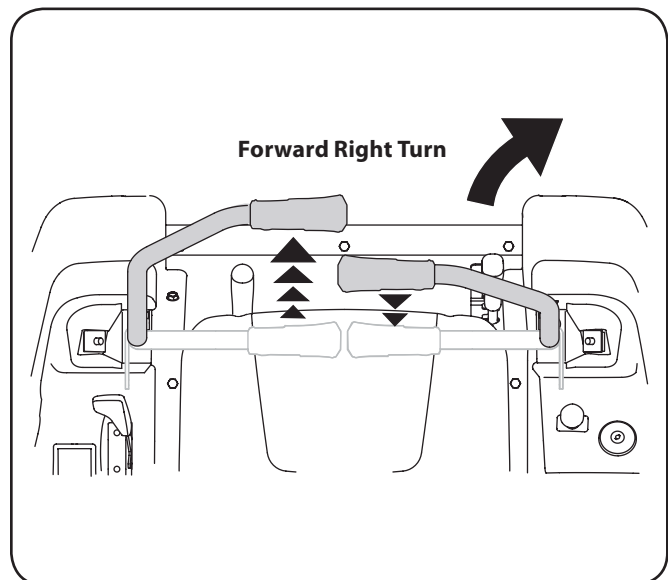

Figure 5-5

3. The greater the fore-to-aft distance between the two levers, the sharper the tractor will turn.
4. To execute a "pivot turn," move the turn side drive control lever to the neutral position, while moving the other control lever forward.

**NOTE:** Making a "pivot turn" on grass will greatly increase the potential for defacement of the turf.

## Driving the Tractor In Reverse



**WARNING!** Always look behind and down on both sides of the tractor before backing up. Always look behind while traveling in the reverse direction.

1. Slowly and evenly move both drive control levers rearward. The tractor will start to move in the reverse direction. See Fig. 5-6.

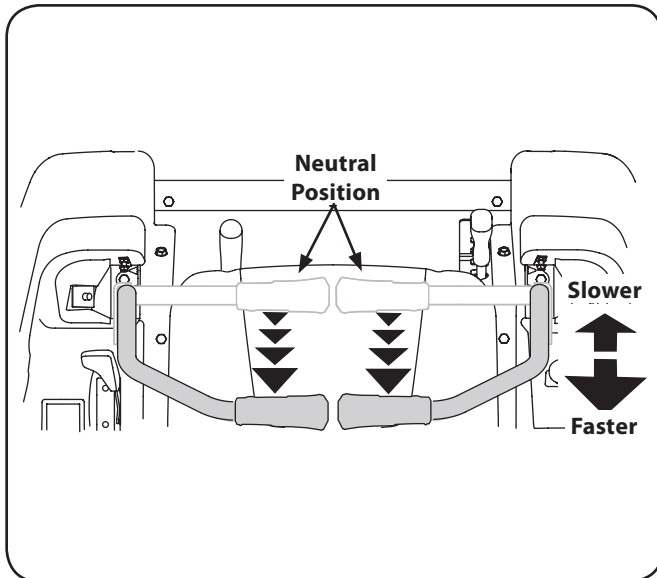

Figure 5-6

2. As the control levers are pushed farther rearward the speed of the tractor will increase.
3. To slow the tractor move the controls lever forward to attain the desired speed, or move the levers to the neutral position to stop the tractor.

## Turning While Driving Rearward

To turn the tractor while driving rearward, move the control levers as necessary so that one lever is forward of the other. The tractor will turn in the direction of the forward control lever.

1. To turn to the left while traveling in reverse, move the left drive control lever forward of the right lever. See Fig. 5-7.

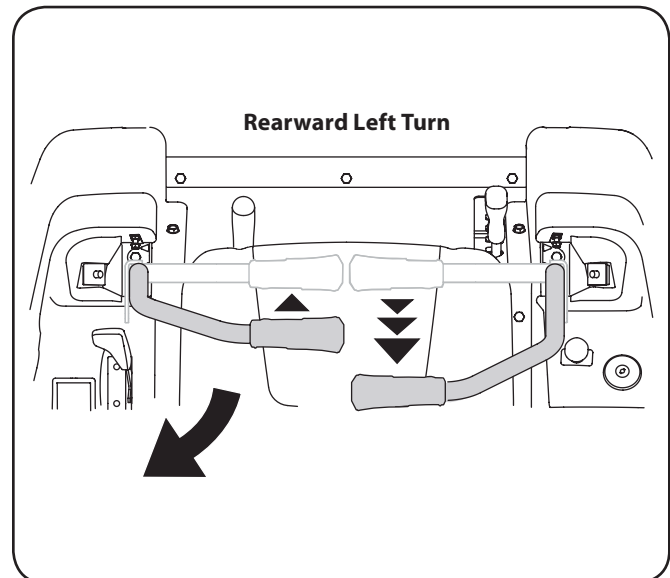

Figure 5-7

2. To turn to the right while traveling in reverse, move the right drive control lever forward of the left lever. See Fig. 5-8.

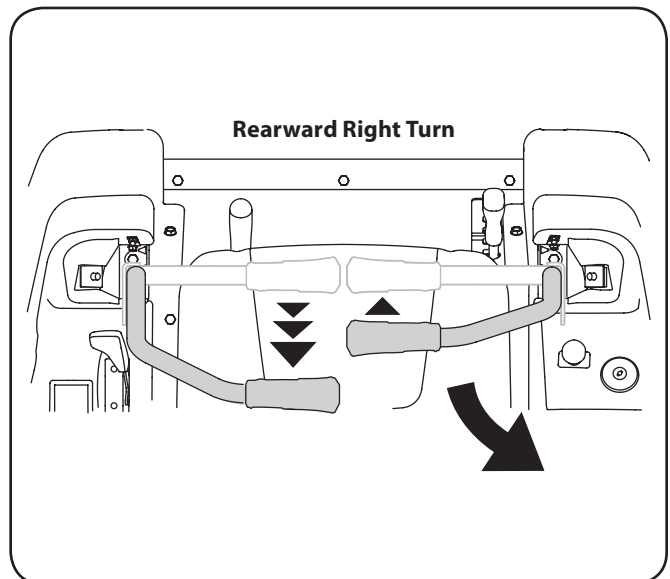

Figure 5-8

3. The greater the fore-to-aft distance between the two levers, the sharper the tractor will turn.
4. To execute a "pivot turn," move the turn side drive control lever to the neutral position, while moving the other control lever rearward.

**NOTE:** Making a "pivot turn" on grass will greatly increase the potential for defacement of the turf.

## Executing a Zero Turn



**WARNING!** When executing a zero turn, the tractor **MUST BE STOPPED**. Executing a zero turn while the tractor is moving can significantly reduce your control of the tractor and will cause severe turf defacement to occur.

1. Stop the forward or reverse motion of the tractor by moving the two drive control levers to neutral.
2. To turn clockwise, move the left control lever forward while simultaneously moving the right control lever rearward. See Fig. 5-9.

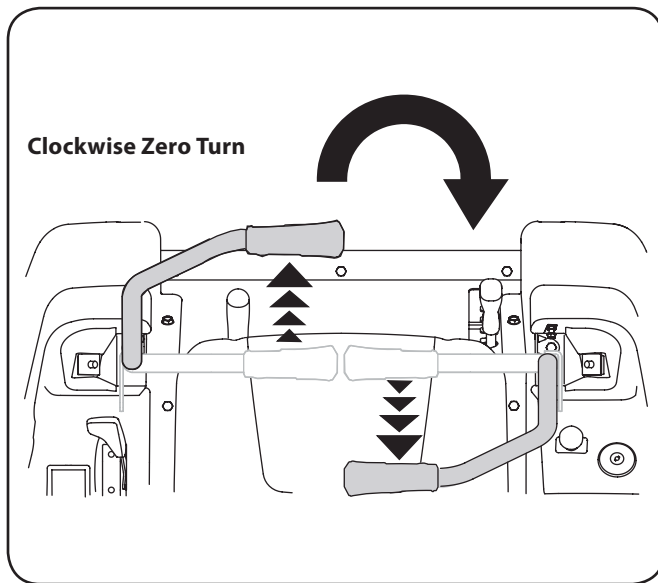

Figure 5-9

3. To turn counterclockwise, move the right control lever forward while simultaneously moving the left control lever rearward. See Fig. 5-10.

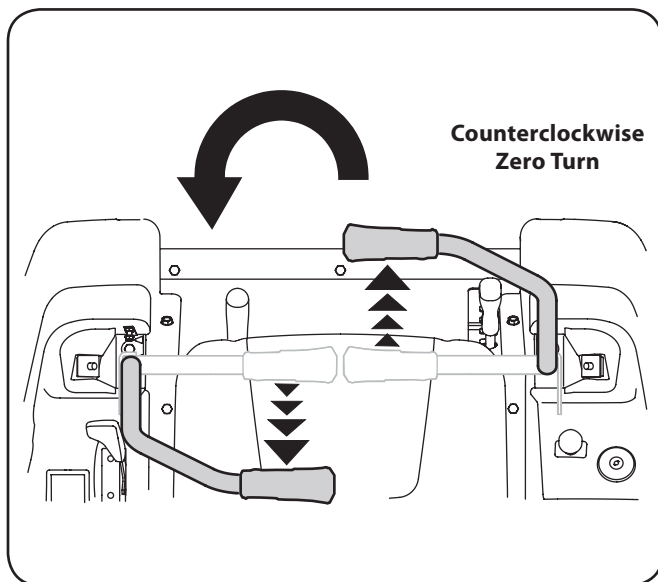

Figure 5-10

## Stopping the Tractor

1. Move both drive control levers to the neutral position to stop the motion of the tractor.
2. Push the PTO switch downward to the disengaged position.
3. Use the deck lift handle to raise the deck to its highest position.
4. If dismounting the tractor, move the drive control handles fully outward in the neutral position, engage the parking brake, move the throttle/choke control lever to the fast position, turn the ignition switch to "OFF" and remove the key from the switch.



**WARNING!** Do not leave the seat of the tractor without disengaging the PTO, moving drive control levers fully outward in the neutral position, and engaging the parking brake. If leaving the tractor unattended, turn the ignition key off and remove key.

## Driving On Slopes

Refer to the slope gauge in the Safe Operation Section to help determine slopes where you may not operate safely.



**WARNING!** Do not operate on inclines with a slope in excess of 15 degrees (a rise of approximately 2-1/2 feet every 10 feet). The tractor could overturn and cause serious injury.

1. Always drive across slopes, never up and down. Control the speed and direction of the tractor using primarily the control lever on the downhill side of the tractor, with the uphill control lever remaining essentially in a fixed position.
2. Avoid turning downhill if possible. Start at the bottom of a slope and work upward. Always slow down before turning.
3. Use extra care and go slowly when turning downhill.

## Operating The PTO

Operate the PTO clutch as follows:

1. Move the throttle/choke control lever to approximately the mid throttle position.
2. Pull the PTO switch upward to the "ENGAGED" position.
3. Advance the throttle/choke lever to the operating speed (full engine speed).
4. The operator must remain in the tractor seat at all times. If the operator should leave the seat without turning off the power take-off switch, the tractor's engine will shut off.
5. The PTO clutch cannot be operated when the tractor is driving in the reverse direction. The PTO will disengage when both drive control levers are moved to the reverse position, and will re-engage when one (or both) control lever(s) is moved to the neutral or forward position.

## Using the Mower Deck



**WARNING!** Make certain the area to be mowed is free of debris, sticks, stones, wire or other objects that can be thrown by the rotating blades.

**NOTE:** Do not engage the mower deck when lowered in grass. Premature wear and possible failure of the 'V' belt and PTO clutch will result. Fully raise the deck or move to a non grassy area before engaging the mower deck.

1. Mow across slopes, not up and down. If mowing a slope, start at bottom and work upward to ensure turns are made uphill.
2. On the first pass pick a point on the opposite side of the area to be mowed.
3. Engage the PTO clutch using the PTO switch and move the throttle/choke control to the fast position.
4. Lower the mower deck to the desired height setting using the lift handle.
5. Slowly and evenly push the RH and LH drive control levers forward to move the tractor forward, and keep the tractor headed directly toward the alignment point.

**NOTE:** The speed of the tractor will affect the quality of the mower cut. Mowing at full speed will adversely affect the cut quality. Control the ground speed with the control levers.

6. When approaching the other end of the strip, slow down or stop before turning. A U-turn is recommended unless a pivot or zero turn is required.
7. Align the mower with an edge of the mowed strip and overlap approximately 3".
8. Direct the tractor on each subsequent strip to align with a previously cut strip.
9. To prevent rutting or grooving of the turf, if possible, change the direction that the strips are mowed by approximately 45° for the next and each subsequent mowing.



**WARNING!** Be careful when crossing gravel paths or driveways. Disengage the PTO and raise the deck to the highest position before crossing.

**NOTE:** When stopping the tractor for any reason while on a grass surface, always:

- Place the shift lever in neutral,
- Engage the parking brake,
- Shut engine off and remove the key.
- Doing so will minimize the possibility of having your lawn "browned" by hot exhaust from your tractor's running engine.

## Checking the Safety Interlock Circuits

Periodically check the safety interlock circuits to ensure they are working properly. If a safety circuit is not working as designed, contact your Cub Cadet dealer to have the tractor inspected. DO NOT operate the tractor if any safety circuit is not functioning properly. To check the safety circuits, proceed as follows:

1. Sitting in the tractor seat with both drive control levers opened fully outward, disengage the parking brake and momentarily turn the ignition switch to the start position. The engine should not crank.
2. Engage the parking brake and pull the PTO switch upward to the engaged position. Momentarily turn the ignition switch to the start position; the engine should not crank.
3. Push the PTO switch downward to the disengaged position and engage the parking brake. Start the engine and move one of the drive control levers from the fully outward neutral position. The engine should stop running. Repeat the procedure with the opposite control lever.
4. Move both control levers fully outward in the neutral position and disengage the parking brake; then lift upward from the operator's seat. The engine should stop.
5. With both control levers fully outward in the neutral position and the parking brake engaged, engage the PTO. Lift upward from the operator's seat; the engine should stop.
6. Start the tractor, disengage the parking brake, and move the control levers inward to the neutral operating position. Engage the PTO and move both control lever slowly into the slow reverse position; the PTO should disengage and the mower deck should stop until one or both of the control levers is moved to the neutral or forward position.

## Maintenance Schedule

	Before Each use	Every 10 Hours	Every 25 Hours	Every 50 Hours	Every 100 Hours	Prior to Storing
Check Engine Intake Screen/Cover	✓					
Clean Hood/Dash Louvers		✓				✓
Check Engine Oil Level	✓	✓				
Check Air Filter for Dirty, Loose or Damaged Parts	✓					
Clean and Re-oil Air Filter's Foam Precleaner			✓			
Replace Air Filter Element					✓	
Change Engine Oil and Replace Oil Filter				✓		
Clean Battery Terminals		✓				✓
Lube Front Pivot Axle and Caster Axles		✓				✓
Clean Engine Cooling Fins			✓			✓
Lube Front Deck Wheels			✓			✓
Check Spark Plug Condition & Gap					✓	✓
Replace Fuel Filter					✓	

## Maintenance



**WARNING!** Before performing any maintenance or repairs, disengage the PTO, move the drive control levers fully outward in the neutral position, engage the parking brake, stop the engine and remove the key to prevent unintended starting.

### Engine

Refer to the Briggs & Stratton Owner's Manual for all engine maintenance intervals, procedures, specifications and instructions.

### Hydrostatic Transmission

The zero turn tractor is equipped with dual integrated hydrostatic pumps/transaxles that are sealed and are maintenance-free. Fluid levels cannot be checked and fluid cannot be added or changed.

## Changing the Engine Oil



**WARNING!** If the engine has been recently run, the engine, muffler and surrounding metal surfaces will be hot and can cause burns to the skin. Exercise caution to avoid burns.

To complete an oil change, proceed as follows:

1. Run the engine for a short time to warm the engine oil. The oil will flow more freely and carry away more impurities. Use care to avoid burns from hot oil.
2. Locate the oil drain port on the right side of the engine.

3. Pop open the protective cap on the end of the oil drain valve to expose the drain port. Refer to Fig. 6-1. Remove the oil fill cap/dipstick from the oil fill tube.

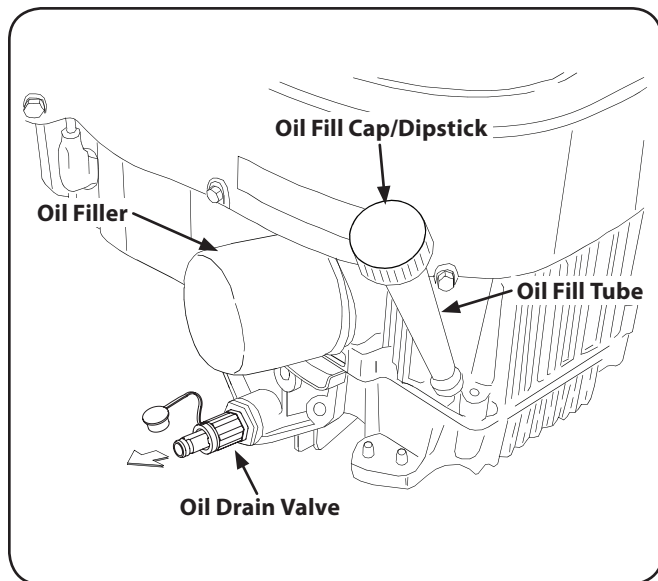

**Figure 6-1**

4. Push the oil drain hose (packed with this manual) onto the oil drain port. Route the opposite end of the hose into an appropriate oil collection container with at least a 2.5 quart capacity, to collect the used oil.
5. The engine is equipped with either a twist-and-pull drain port or a tabbed drain port. If your engine has the twist-and-pull drain go to step a. If your engine is equipped with the tabbed drain go to step b.
  - a. Turn the oil drain valve  $\frac{1}{4}$ -turn, then pull outward to begin draining oil. After the oil has finished draining, push the end of the oil drain valve back in and turn  $\frac{1}{4}$ -turn to secure it back in place. Re-cap the end of the oil drain valve to keep debris from entering the drain port.
  - b. Pinch the tabs on the oil drain valve, then pull outward to begin draining oil. After the oil has finished draining, push the end of the oil drain valve back in, until the tabs click into place. Re-cap the end of the oil drain valve to keep debris from entering the drain port.
6. After the oil has finished draining, push the end of the oil drain valve back in, until the tabs click into place. Re-cap the end of the oil drain valve to keep debris from entering the drain port.
7. Replace the oil filter, and refill the engine with new oil as instructed in the Briggs & Stratton Owner's Manual.

### Air Cleaner

Service the pre-cleaner and cartridge/air cleaner element as instructed in the Briggs & Stratton Owner's Manual.

### Spark Plug

The spark plugs should be cleaned and the gap reset once a season. Refer to the Briggs & Stratton Owner's Manual for correct plug type and gap specifications.

## General Battery Information



### WARNING!

- Should battery acid accidentally splatter into the eyes or onto the skin, rinse the affected area immediately with clean cold water. If there is any further discomfort, seek prompt medical attention.
- If acid spills on clothing, first dilute it with clean water, then neutralize with a solution of ammonia/water or baking soda/water.
- NEVER connect (or disconnect) battery charger clips to the battery while the charger is turned on, as it can cause sparks.
- Keep all sources of ignition (cigarettes, matches, lighters) away from the battery. The gas generated during charging can be combustible.
- As a further precaution, only charge the battery in a well ventilated area.
- Always shield eyes and protect skin and clothing when working near batteries.
- Batteries contain sulfuric acid and may emit explosive gases. Use extreme caution when handling batteries. Keep batteries out of the reach of children.

## Battery Maintenance

- The battery is filled with battery acid and then sealed at the factory. However, even a "maintenance free" battery requires some maintenance to ensure its proper life cycle.
- Spray the terminals and exposed wire with a battery terminal sealer, or coat the terminals with a thin coat of grease or petroleum jelly, to protect against corrosion.
- Always keep the battery cables and terminals clean and free of corrosion.
- Avoid tipping. Even a sealed battery will leak electrolyte when tipped.



**WARNING!** Batteries contain sulfuric acid and may emit explosive gases. Use extreme caution when handling batteries. Keep batteries out of the reach of children.

## Tire Maintenance

Check the tire air pressure after every 50 hours of operation or weekly. Keep the tires inflated to the recommended pressures. Improper inflation will shorten the tire service life. See the tire side wall for proper inflation pressures. Observe the following guidelines:

- Do not inflate a tire above the maximum pressure shown on the sidewall of the tire.
- Do not reinflate a tire that has been run flat or seriously under inflated. Have a qualified tire mechanic inspect and service the tire.

## Lubrication

- Using a pressure lubricating gun, lubricate the front castor wheel axles and the front pivot axle with Cub Cadet 251H EP grease after every 10 hours of service.

- Periodically lubricate all other pivot points with a quality lubricating oil.

### Using the Deck Wash System



**WARNING!** When using the deck wash system, never engage the deck from any position other than the operator's seat of the tractor. Do not use an assistant or engage deck in the presence of any bystanders.

1. Attach the nozzle adapter to a standard garden hose connected to a water supply.
2. Move the tractor to an area within reach of the hose where the dispersal of wet grass clippings is not objectionable to you. Disengage the PTO, engage the parking brake, and stop the engine.
3. Pull back the lock collar of the nozzle adapter and push the adapter onto one of the deck wash nozzles at either end of the mower deck. Release the lock collar to lock the adapter on the nozzle. See Fig. 6-2.

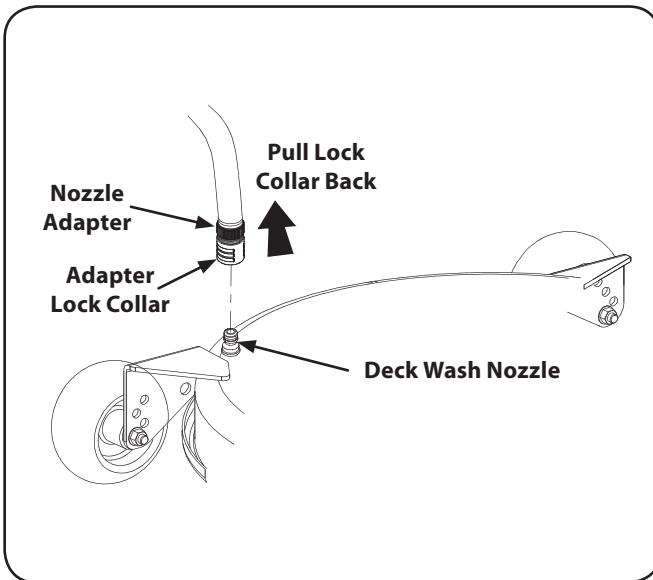

**Figure 6-2**

4. Turn on the water supply.
5. From the tractor operator's seat, start the engine and engage the PTO. Allow to run as needed. Disengage the PTO and stop the engine.
6. Turn off the water supply.
7. Pull back the lock collar of the nozzle adapter to disconnect the adapter from the nozzle.
8. Repeat the previous steps to clean the deck using the nozzle at the other end of the deck.

### Cleaning the Spindle Pulleys

Once a month remove the belt covers to remove any accumulation of grass clippings from around the spindle pulleys and V-belt. Clean more often when mowing tall, dry grass.

### Using the Transmission Bypass Rods

If for any reason the tractor will not drive or you wish to move the tractor, the two hydrostatic transmissions are equipped with a bypass rod that will allow you to manually move the tractor short distances.



**WARNING!** Do not tow the tractor, even with the bypass rod engaged. Serious transmission damage will result from doing so.

1. From just in front of the two rear tires, locate the transmission bypass rods. Refer to Fig. 6-3.

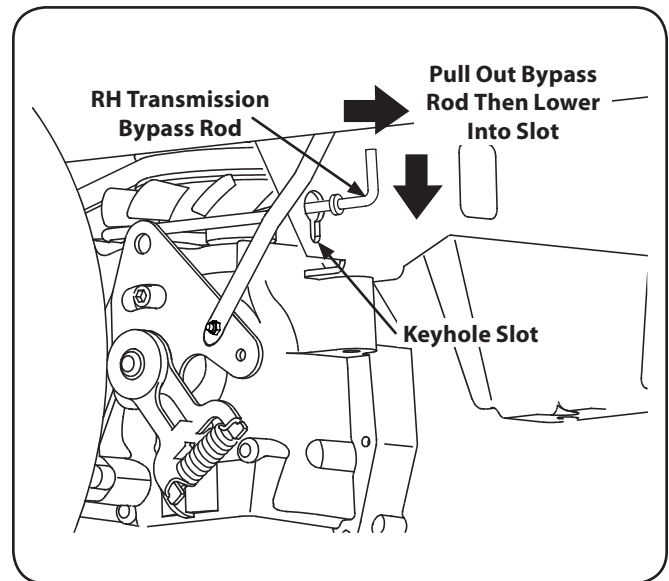

**Figure 6-3**

2. Pull one rod toward the front of the tractor until the flange on the rod is forward of the keyhole slot in the frame assembly.
3. Lower the bypass rod into the keyhole slot and release so the rod flange is against the front of the frame bracket.
4. Repeat the above procedure to engage the other bypass rod on the other side of the tractor.
5. After moving the tractor, disengage both bypass rods. Lift the rod and guide the flange of the rod back through the larger circular opening of the keyhole, then release the rod.

**NOTE:** The tractor will not drive with the bypass rods in the engage position.



## Battery Storage

1. When storing the tractor for extended periods, disconnect the negative battery cable. It is not necessary to remove the battery.
2. All batteries discharge during storage. Keep the exterior of the battery clean, especially the top. A dirty battery will discharge more rapidly.
3. The battery must be stored with a full charge. A discharged battery can freeze sooner than a charged battery. A fully charged battery will store longer in cold temperatures than hot.
4. Recharge the battery before returning to service. Although the tractor may start, the engine charging system may not fully recharge the battery.

## Tractor Storage

If your tractor is not going to be operated for an extended period of time (thirty days to approximately six months), the tractor should be prepared for storage. Store the tractor in a dry and protected location. If stored outside, cover the tractor (including the tires) to protect it from the elements. The procedures outlined below should be performed whenever the tractor is placed in storage.

1. Change the engine oil and filter following the instructions provided in the engine manual packed with this manual.



**WARNING!** Never store the tractor with fuel in the tank indoors or in poorly ventilated enclosures, where fuel fumes may reach an open flame, spark or pilot light as on a furnace, water heater, clothes dryer, etc.

2. If storing the tractor for 30 days or more:
  - a. To prevent gum deposits from forming inside the engine's carburetor and causing possible malfunction of the engine, the fuel system must be either completely emptied, or the gasoline must be treated with a stabilizer to prevent deterioration.



**WARNING!** Fuel left in the fuel tank deteriorates and will cause serious starting problems.

- b. Using a fuel stabilizer:
  - Read the product manufacturer's instructions and recommendations.
  - Add to clean, fresh gasoline the correct amount of stabilizer for the capacity (approximately 3 gallons) of the fuel system.
  - Fill the fuel tank with treated fuel and run the engine for 2-3 minutes to get stabilized fuel into the carburetor.

- c. Emptying the fuel system:
  - Prior to putting the tractor in storage, monitor fuel consumption with the goal of running the fuel tank empty.
  - Run the engine until it begins to stall. Use the choke to keep the engine running until all fuel in the carburetor has been exhausted.
  - Referring to the engine manual, drain the fuel from the carburetor bowl.

3. Clean the engine and the entire tractor thoroughly.
4. Fully charge the battery, then disconnect the negative cable at the battery to prevent possible discharge. Recharge the battery periodically when in storage.

**NOTE:** Remove the battery if exposed to prolonged periods of sub-freezing temperatures. Store in a cool, dry location where temperatures are above freezing.

5. Lubricate all lubrication points.

**NOTE:** Use a pressure washer or garden hose is not recommended to clean your tractor. They may cause damage to electrical components, spindles, pulleys, bearings or the engine. The use of water will result in shortened life and reduce serviceability.

## Removing The Tractor From Storage

1. Check the engine oil.
2. Fully charge the battery and inflate the tires to the recommended pressure.
3. If drained before storing, fill the fuel tank with clean, fresh gasoline.
4. Add clean, fresh fuel.
5. Start the engine and allow to idle for a few minutes to ensure engine is operating properly.
6. Drive the tractor without a load to make certain all the tractor systems are functioning properly.

## Adjustments



**WARNING!** Shut the engine off, remove the ignition key and engage the parking brake before making adjustments. Protect your hands by using heavy gloves when handling the blades.

### Adjusting the Seat

To adjust the position of the seat, pull up and hold the seat adjustment lever. Slide the seat forward or rearward to the desired position; then release the adjustment lever. Make sure seat is locked into position before operating the tractor. See Fig. 6-4.

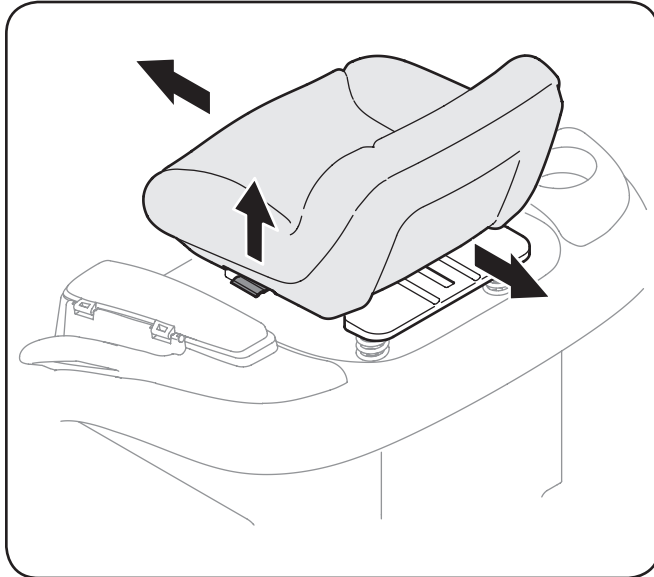

Figure 6-4

### Adjusting RH & LH Drive Control Levers

The RH and LH drive control levers can be adjusted up or down and fore-and-aft for the comfort of the operator. The drive control levers can be placed in either of two height positions, and/or can be moved forward or rearward within the range of the slot in each control lever mounting bracket.

To adjust the drive control lever height, proceed as follows:

1. Remove the flange lock nut, flat washer, and hex screw securing the lever to the pivot bracket.

2. While supporting the control lever to keep it from falling, remove the hex insert flange lock nut and shoulder screw from the bottom of the control lever and pivot bracket. Refer to Fig. 6-5.

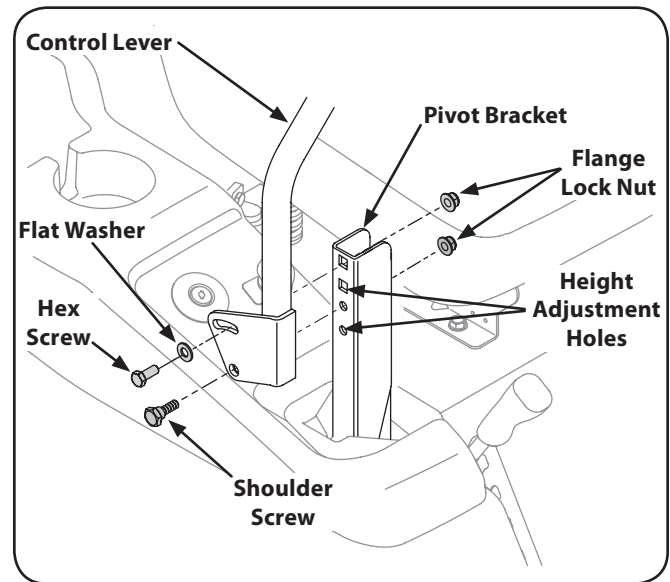

Figure 6-5

3. Reposition the control lever to align with the other set of holes in the pivot bracket and insert the shoulder screw removed earlier. Fasten with the hex insert flange lock nut and tighten until snug.
4. Insert the hex screw with washer through the control lever slot and the pivot bracket. Thread the flange lock nut onto the screw, but do not tighten now.
5. If you are going to adjust the control levers forward or rearward, proceed to the next step. If not, fully tighten the flange lock nut.

To adjust the drive control levers forward or rearward, proceed as follows:

1. If not already loose, loosen the flange lock nut and rotate the control lever either forward or rearward to the desired position. See Fig. 6-5.  
**NOTE:** If the control lever is too tight to move, slightly loosen the hex insert flange lock nut and shoulder screw at the bottom of the control lever.
2. Tighten the flange lock nut to fix the control lever in the adjusted position
3. Repeat the above procedure to adjust the other control lever into the same position. Adjust so that both levers are even with each other when in the neutral position.

## Leveling the Mower Deck

When correctly adjusted the mower deck should be level side to side, and the front of the deck should be approximately ¼" lower than the rear of deck.

**NOTE:** Check the tractor's tire pressure before performing any deck leveling adjustments. See the tire side wall for proper inflation pressures.

### Side to Side Leveling

1. If the cutting deck appears to be mowing unevenly, a side to side adjustment can be performed. Adjust if necessary as follows:
2. With the tractor parked on a firm, level surface, place the deck lift handle in the top notch (highest position) and rotate both outer blades so that they are perpendicular to the tractor frame.
3. Lower the deck to the middle height position.
4. Measure the distance from the outside left blade tip to the ground and the distance from the outside right blade tip to the ground. The measurements should be equal. If they're not, proceed to the next step.
5. Comparing the two measurements, determine whether the left side of the deck must be raised or lowered.
6. Loosen, but do not remove, the hex cap screw on the left deck hanger bracket. See Fig. 6-6.

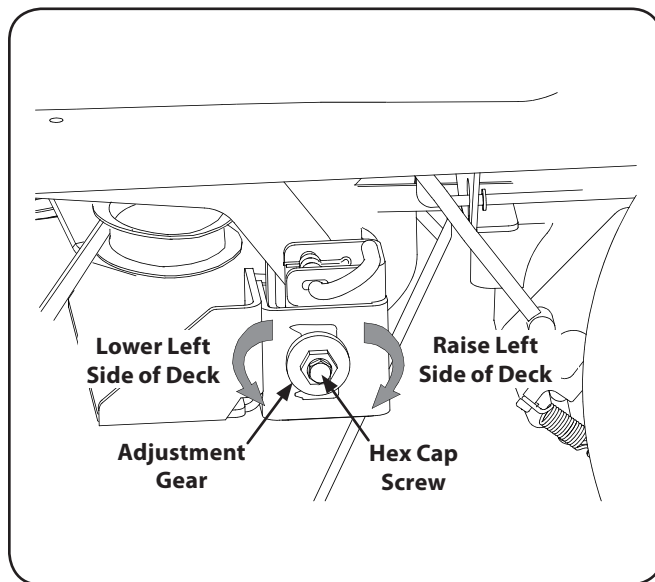

Figure 6-6

7. Level the deck by using a wrench to turn the adjustment gear (found immediately behind the hex cap screw just loosened) clockwise to raise the left side of the deck, or counterclockwise to lower the left side of the deck. See Fig. 6-6.
8. The deck is properly leveled when left and right blade tip measurements are equal.
9. Retighten the hex cap screw on the left deck hanger bracket when proper adjustment is achieved.

### Front to Back Leveling.

1. The front of the deck should be approximately ¼" lower than the rear of the deck. Adjust if necessary as follows:
2. With the deck raised off of the ground, rotate the outer blades so that they are parallel to the frame of the tractor.
3. If the side to side leveling was done correctly, measuring just the right blade should be acceptable to attain the correct back to front pitch of the deck.
4. Measure the distance from the front tip of the blade to the ground and the distance from the rear tip to the ground. The front distance should be approximately ¼" less than the rear. If it is not, proceed to the next step.
5. From the front of the tractor, loosen the outer hex nuts on the deck front hanger rod and turn them away from the inner nuts. Refer to Fig. 6-7.

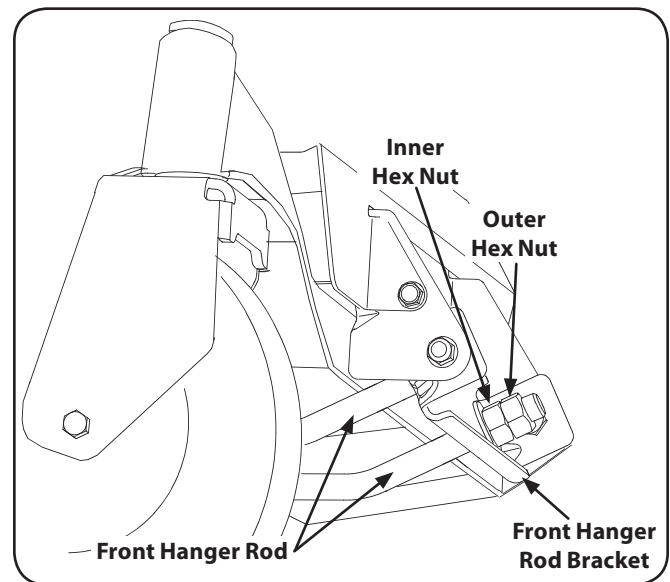

Figure 6-7

6. If the front of the deck was too low, turn the inner hex nuts clockwise against the hanger bracket to shorten the front hanger rod and raise the front of the deck. Refer to Fig. 6-7.
7. If the front of the deck was too high, turn the hex nuts counterclockwise to lengthen the front hanger rod and lower the front of the deck.

**NOTE:** The deck front hanger rod should be at the front of the slots of the front deck bracket. If one side of the rod is not at the front of its slot, turn the inner hex nut on that side until rod just touches the front of the slot. Then re-measure and re-adjust the front hanger rod as necessary.

8. When the correct pitch of the deck is acquired, secure the inner hex nuts with a wrench and tighten the outer hex nuts against the inner hex nuts to lock them in the adjusted position.

## Adjusting the Gauge Wheels



**WARNING!** Keep hands and feet away from the discharge opening of the cutting deck.

**NOTE:** The deck gauge wheels are an anti-scalp feature of the deck and are not designed to support the weight of the cutting deck.

The mower deck cutting height can be set in any of six height settings using the tractor's deck lift handle. The deck heights range from 1- $\frac{1}{2}$ " to 4". The deck gauge wheel position should be approximately  $\frac{1}{4}$  to  $\frac{1}{2}$ " above the ground when the deck is set in the desired height setting.

Using the lift handle, set the deck in the desired height setting, then check the gauge wheel distance from the ground below. If necessary adjust as follows:

1. Visually check the distance between the front gauge wheels and the ground. If the gauge wheels are near or touching the ground, they should be raised. If more than  $\frac{1}{2}$ " above the ground, they should be lowered.
2. Remove the lock nut securing one of the front gauge wheel shoulder screws to the deck. Remove the gauge wheel and shoulder screw. Refer to Fig. 6-8.

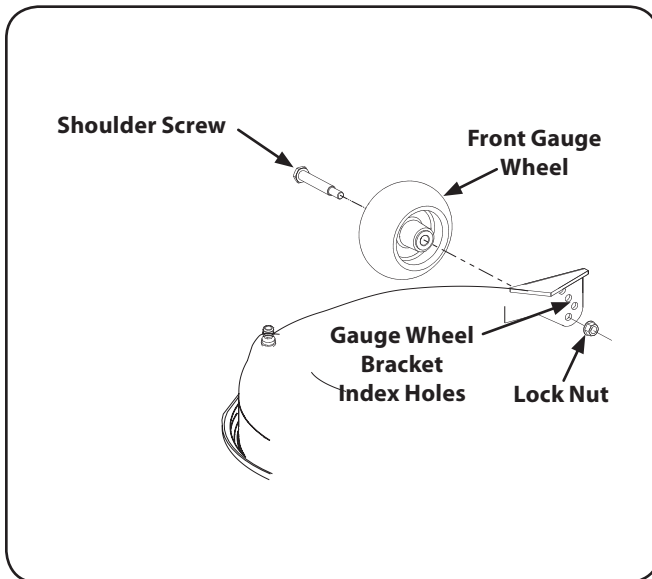

**Figure 6-8**

3. Insert the shoulder screw into the one of four index holes in the front gauge wheel bracket that will give the gauge wheel a  $\frac{1}{4}$ " to  $\frac{1}{2}$ " clearance with the ground.
4. Note the index hole of the just adjusted wheel, and adjust the other gauge wheels into the respective index holes of the other gauge wheel brackets on the deck.

## Battery Removal



**WARNING!** Battery posts, terminals and related accessories contain lead and lead compounds. Wash hands after handling.

The battery is located on the right/rear of the tractor beneath the seat box frame. To remove the battery:

1. Remove the two hex tapping screws from the battery hold-down bracket and remove the bracket. Use care to avoid losing the trim strip from the bottom of the bracket. See Fig. 7-1.

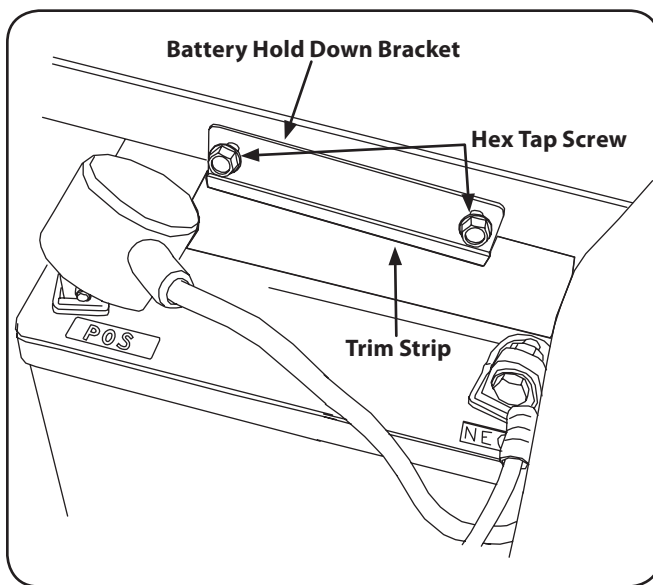

Figure 7-1

2. Remove the hex cap screw and sems nut securing the black negative battery lead to the negative battery post (marked NEG). Move the cable away from the negative battery post.
3. Remove the hex cap screw and sems nut securing the red positive battery lead to the positive battery post (marked POS).
4. Carefully lift the battery out of the tractor.
5. Install the battery by repeating the above steps in the reverse order.



**WARNING!** Always connect the positive lead to the battery before connecting the negative lead. This will prevent sparking or possible injury from an electrical short caused by contacting the tractor body with tools being used to connect the cables.

## Charging the Battery

Test and, if necessary, recharge the battery after the tractor has been stored for a period of time.

- A voltmeter or load tester should read 12.6 volts (DC) or higher across the battery terminals. See Fig. 7-2.

Voltmeter Reading	State of Charge	Charging Time
12.7	100%	Full Charge
12.4	75%	90 Min.
12.2	50%	180 Min.
12.0	25%	280 Min.

Figure 7-2

- Charge the battery with a 12-volt battery charger at a MAXIMUM rate of 10 amps.

## Servicing Electrical System

A fuse is installed to protect the tractor's electrical system from damage caused by excessive amperage. Always use the same capacity fuse for replacement. If the electrical system does not function, check for a blown fuse. See Fig. 7-3.

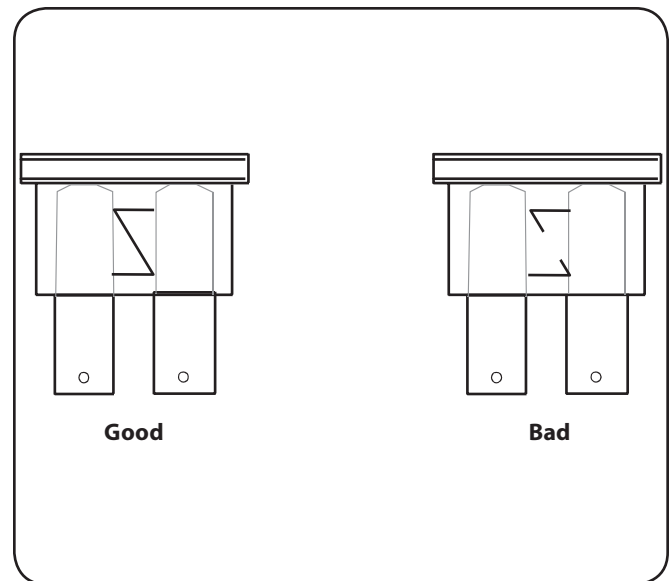

Figure 7-3

If you have a recurring problem with blown fuses, have the tractor's electrical system checked by your Cub Cadet Service Dealer

## Relays and Switches

There are several safety switches in the electrical system. If a function of the safety interlock system described earlier is not functioning properly, have the electrical system checked by your Cub Cadet Service Dealer.

## Deck Removal

Remove the mower deck from the tractor as follows:

1. Move the tractor to a level surface, disengage the PTO, stop the engine, and set the parking brake.
2. Move the deck gauge wheels or rollers to their highest setting (lowest deck setting).
3. Remove the 'V' belt from the PTO pulley, located on the bottom of the engine, using one of the following two methods.



**WARNING!** The muffler at the rear of the tractor may be extremely hot, and could cause serious burns. Use extreme caution when near the muffler. Allow the muffler to fully cool before removing the belt from the PTO pulley.

### Releasing Belt Tension with the Idler Pulley

1. Using the deck lift handle, raise the deck to the position that provides the most horizontal run of the belt between the deck idler pulleys and the PTO pulley on the bottom of the engine.
2. Working from the middle of the tractor, pivot the idler bracket and movable idler pulley rearward away from the backside of the 'V' belt just far enough to lift the belt up and over the idler pulley. See Fig. 7-4.

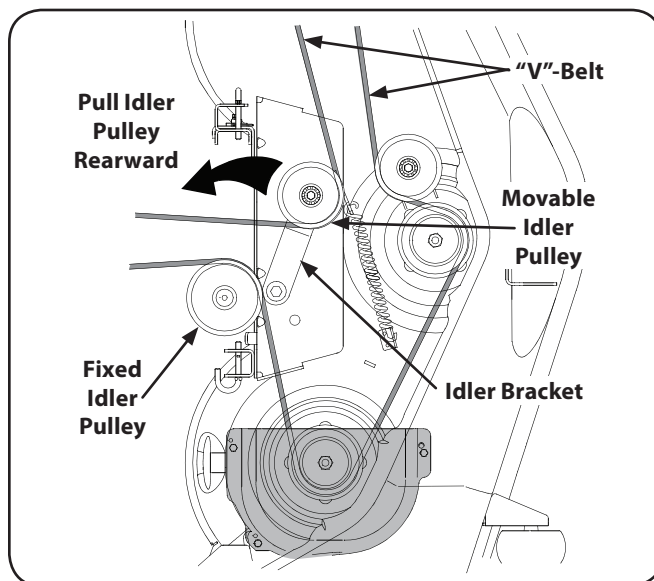

Figure 7-4

3. From beneath the rear of the tractor, slide the belt off of the PTO pulley on the bottom of the engine.

### Rolling the Belt off the PTO Pulley

1. Using the deck lift handle, raise the deck to the position that provides the most horizontal run of the belt between the deck idler pulleys and the PTO pulley on the bottom of the engine.
2. Sitting behind the tractor facing forward, reach beneath the tractor to grasp the belt at the front of the PTO pulley.



**WARNING!** Use caution to avoid pinching your fingers when rolling the belt off the PTO pulley.

3. Pull the left side of the belt rearward and downward while manually turning the PTO pulley to the right until the belt rides out onto the edge of the lower sheave of the pulley.  
**NOTE:** If pulling the right side of the belt, turn the pulley to the left.
4. While still holding the belt downward, continue turning the PTO pulley until the belt is rolled off the pulley. Refer to Fig. 7-5.

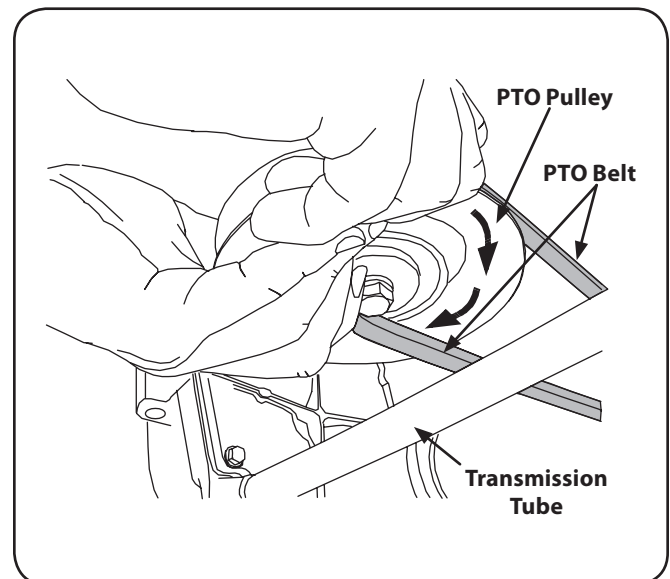
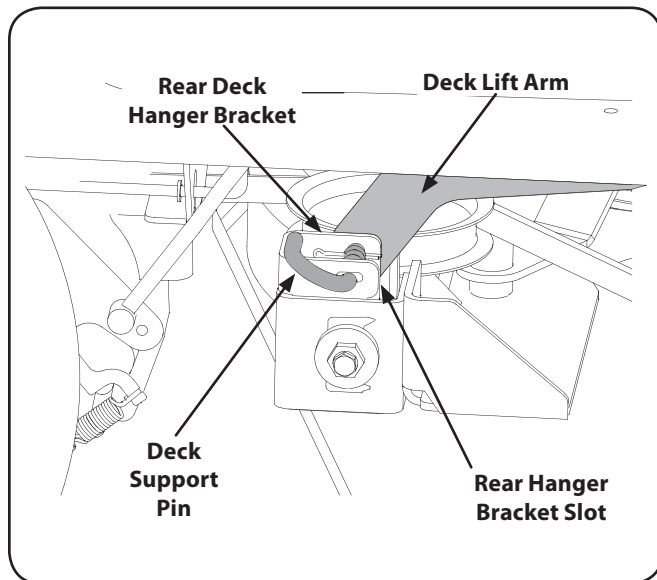

Figure 7-5

5. Lower the deck to the ground using the deck lift handle.
6. Locate the LH and RH deck support pins on each side of the deck. Pull the deck support pins outward and lock in the disengaged position to release the deck from the tractor's LH and RH deck lift arms. Refer to Fig. 7-6.



**Figure 7-6**

7. Raise the deck lift arms out of the rear hanger bracket slots by raising the deck lift handle on the tractor to its highest position. Refer to Fig. 7-6.
8. Slide the deck forward so that the deck front hanger rod can be lifted out of the two slots of the front deck bracket. After lifting the front hanger rod out of the slots, slide the deck rearward so that the rod can no longer engage the slots.
9. Using care to prevent the front hanger rod from falling back into the deck bracket slots, carefully slide the cutting deck (from the right side) out from underneath the tractor.

## Deck Installation

To install the mower deck, proceed as follows:

1. While holding the deck front hanger rod upward, carefully slide the deck underneath the right side of the tractor.
2. While still holding the front hanger rod, slide the deck forward until the front hanger rod can be lowered into the slots of the front deck bracket.
3. Lower the front hanger rod into the slots of the front deck bracket, then slide the deck rearward.
4. Maneuver the deck so that the slots in the two rear deck hanger brackets approximately align with the deck lift arms of the tractor. Refer to Fig. 7-6.
5. Use the tractor deck lift handle to lower the deck lift arms into the slots of the rear deck hanger brackets.
6. Pull the deck support pins outward and maneuver the deck as necessary to align the holes in the deck lift arms with the pins. Refer to Fig. 7-6.
7. When aligned, push each pin fully inward through the lift arms to secure the arms in the rear hanger bracket slots.
8. Make certain the 'V' belt is in the spindle pulleys on the deck; then route the belt rearward beneath the tractor frame, above the transmission tube(s), to the PTO pulley on the bottom of the engine.
9. Install the 'V' belt onto the PTO pulley using one of the following two methods.



**WARNING!** The muffler at the rear of the tractor may be extremely hot, and could cause serious burns. Use extreme caution when near the muffler. Allow the muffler to fully cool before installing the belt.

### Using the Idler Pulley to Tension the Belt.

1. Using the deck lift handle, raise the deck to the position that provides the most horizontal run of the belt between the deck idler pulleys and the PTO pulley on the bottom of the engine.
2. Install the belt in the PTO pulley on the bottom of the engine.
3. Route the backside of the belt around the fixed idler pulley of the deck. Refer to Fig. 7-4.
4. Working from the middle of the tractor, pivot the idler bracket/movable pulley rearward against the spring tension and slide the backside of the belt onto the movable idler pulley. Refer to Fig. 7-4.

## Rolling the Belt onto the PTO Pulley.

1. Using the deck lift handle, raise the deck to the position that provides the most horizontal run of the belt between the deck idler pulleys and the PTO pulley on the bottom of the engine.
2. Make certain the belt is in the spindle pulleys of the deck, and that the backside of the belt is against both the fixed and movable idler pulleys. Refer to Fig. 7-4.
3. Sitting behind the tractor, facing forward, make certain the belt is not twisted; then reach beneath the tractor to grasp the belt and pull it toward the PTO pulley.



**WARNING!** Use caution to avoid pinching your fingers when rolling the belt onto the PTO pulley.

4. Pull the right side of the belt rearward and place the narrow V side of the belt into the PTO pulley. See Fig. 7-5.
5. While holding the belt and pulley together, rotate the pulley to the left (See Fig. 7-5). Continue holding and rotating the pulley and belt until the belt is fully rolled into the PTO pulley.

## Replacing the Deck Drive Belt

1. Remove the deck from beneath the tractor, (refer to Deck Removal on page 29).
2. Remove the hex tapping screws securing the belt covers to the deck and remove the belt from the spindle pulleys. Refer to Fig. 7-7.

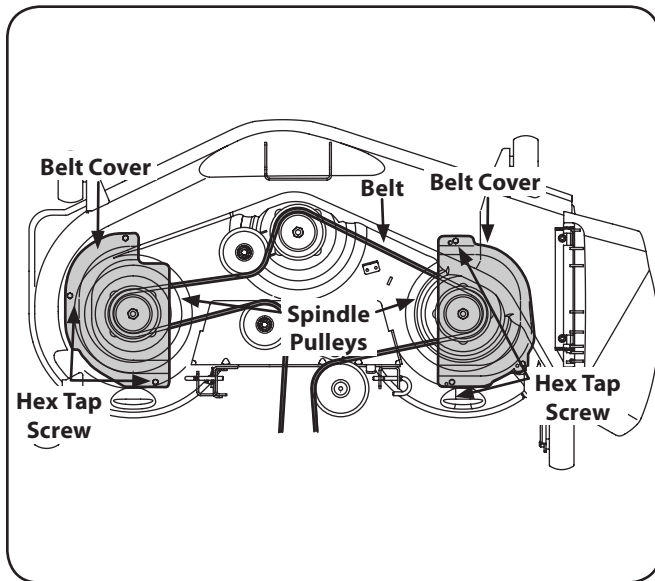

Figure 7-7

3. Install the new belt around the spindle pulleys as shown in Fig. 7-7 and reinstall the belt covers.
4. Route the belt rearward between the two idler pulleys and reinstall the deck following the instructions in Deck Installation on page 30.

## Mower Blade Care



**WARNING!** Before performing any maintenance, place the PTO switch in the “OFF” position, engage the parking brake lever, turn the ignition key to the “OFF” position and remove the key from the switch. Protect your hands by using heavy gloves when handling the blades. When servicing the mower deck, be careful not to cut yourself on the sharpened blades.

The cutting blades must be kept sharp at all times. Sharpen the cutting edges of the blades evenly so that the blades remain balanced and the same angle of sharpness is maintained.

If the cutting edge of a blade has already been sharpened many times, or if any metal separation is present, it is recommended that new blades be installed. New blades are available at your authorized dealer.

The blades may be removed as follows.

1. Remove the deck from beneath the tractor, (refer to Deck Removal on page 29) then gently flip the deck over to expose its underside.
2. Use a  $1\frac{5}{16}$ ” wrench to hold the hex nut on top of the spindle assembly when loosening the hex nut securing the blade. A block of wood may be placed between the deck housing and the cutting edge of the blade to help in breaking loose the hex nut securing the blade. See Fig. 7-8.

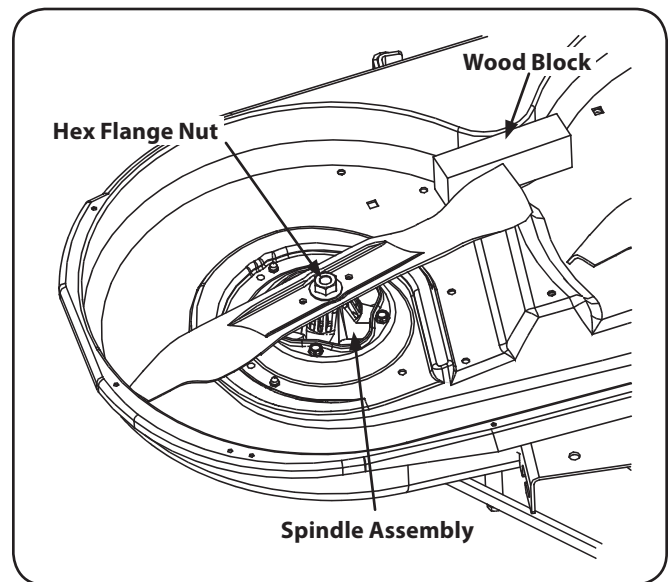

Figure 7-8



- When reinstalling the blades, be sure they are installed so that the wind wings are pointing upward toward the top of the deck.
- Tighten the blade nuts to 70-90 ft. lbs.
- Reinstall the deck (refer to Deck Installation on page 30).

## Transmission Drive Belt

If the transmission drive belt becomes worn and causes the drive transmissions to slip, the drive belt must be replaced. To replace the drive belt, proceed as follows:

- Remove the deck drive belt from the PTO clutch on the bottom of the engine following the instructions in Deck Removal.
- From beneath the rear of the tractor, insert a  $\frac{3}{8}$ " drive ratchet into the square hole of the drive idler bracket. See Fig. 7-9.

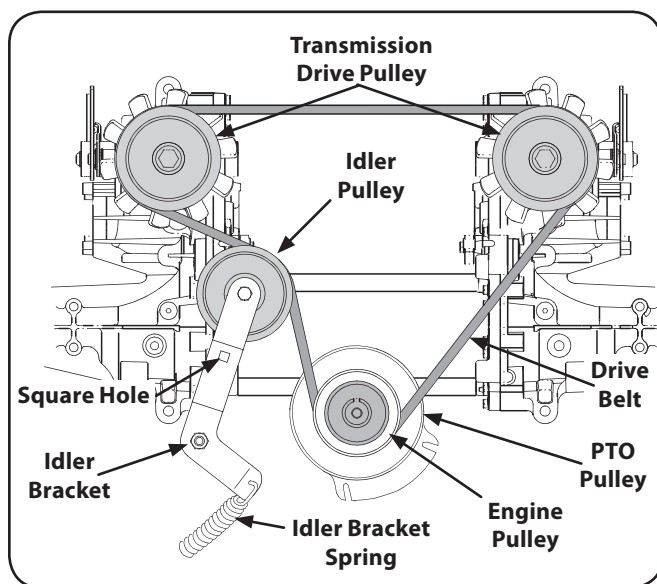

Figure 7-9

- Using the ratchet for leverage, pivot the idler bracket and idler pulley away from the backside of the 'V' belt; then lift the belt off and above the engine pulley and off the idler pulley.
- With the belt loose, lift the belt off, up and over the two transmission drive pulleys. Remove the belt from the engine and idler pulleys.
- Loop the new belt and slide over and onto the two transmission pulleys.
- Route the belt above the idler bracket back to the engine drive pulley. Lift the belt over the PTO pulley and above the engine drive pulley.
- Using the ratchet for leverage, pivot the idler bracket and idler pulley against the spring tension; then slip the belt down into the engine drive pulley and onto the idler pulley.
- Release the idler bracket so that the idler pulley tightens against the back side of the belt and tensions the drive belt.
- Reinstall the deck drive belt.

## Tractor Creeping

Creeping is the slight forward or backward movement of the tractor when the engine is running at high idle and the drive control levers are opened out in the neutral position.

If after operating the tractor for some time, it begins to creep while in the neutral position, adjust the transmission control rods as follows.

- Place the front of the tractor against an immovable object (e.g. wall, post, etc.).
- Jack up the rear of the tractor so that both rear wheels are approximately one inch off the ground.
- With the engine running at high idle and the drive control levers opened out in the neutral position, and the parking brake disengaged, check the rear wheels for rotation.
- If only one wheel is rotating, locate the transmission control rod beneath the frame at the front of the rear tire. If both wheels rotate, locate both control rods. See Fig. 7-10.

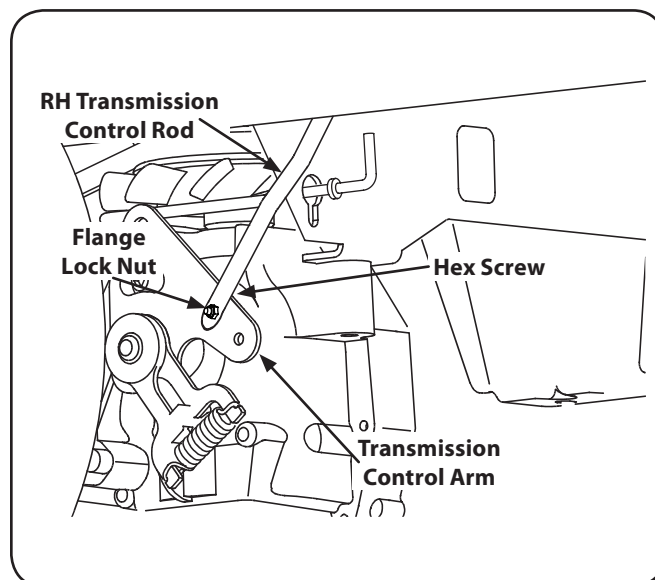

Figure 7-10

- Remove the flange lock nut and hex screw securing the transmission control rod to the transmission control arm. Wheel rotation should stop. If it does not, contact your Cub Cadet Service Dealer.
- If the rotation stops, adjust the control rod up or down as necessary to align with the hole in the transmission control arm. Re-insert the hex nut into the hole in the control arm and secure with the hex lock nut.
- If necessary, repeat the previous two steps to adjust the other transmission control rod.
- Lower the tractor and remove the jack.

## Tractor High Speed Tracking

If the tractor tracks to one side with both drive control levers fully forward, adjust the control levers as follows:

1. Check for proper and balanced air pressure in both front and rear tires. Refill tires if necessary.
2. Perform the first three steps in the previous sub-section, Tractor Creeping, to verify that the tractor is not creeping. If creeping, adjust following the instructions in that sub-section.
3. Recheck the tracking after making any adjustments to the transmission control rods.
4. If uneven tracking persists, note which direction the tractor is tracking.
  - a. If the tractor tracks to the right, adjust the control lever stop bolt on the left side.
  - b. If the tractor tracks to the left, adjust the control lever stop bolt on the right side.
5. Locate the applicable stop bolt on the left or right console. See Fig. 7-11.

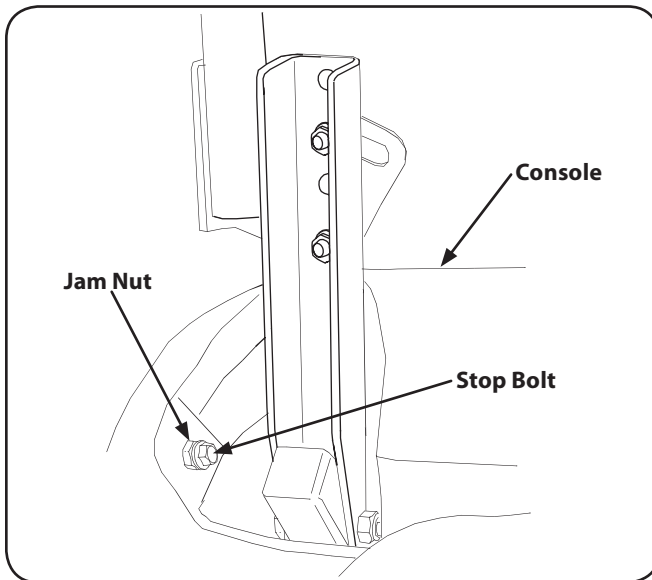

**Figure 7-11**





6. Loosen the jam nut on the stop bolt, then turn the stop bolt counterclockwise to make it longer. Recheck the tracking and fine tune the adjustment as necessary.

**NOTE:** If the stop bolt is adjusted too far, the tracking problem will change sides. Make fine tuning adjustments by shortening the same bolt.
7. Tighten the jam nut against the console and reposition the control lever as necessary to make the two control handles even with each other.



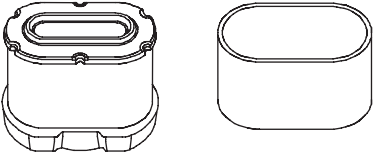

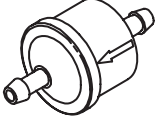
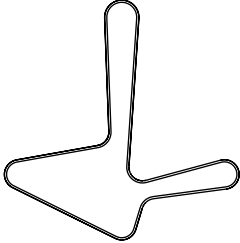
Problem	Cause	Remedy
Engine fails to start	<ol style="list-style-type: none"> <li>1. PTO/Blade Engage knob engaged.</li> <li>2. Parking brake not engaged.</li> <li>3. Drive control levers not fully outward in neutral position.</li> <li>4. Spark plug wire(s) disconnected.</li> <li>5. Throttle/choke control lever not in correct starting position.</li> <li>6. Choke not activated.</li> <li>7. Fuel tank empty, or stale fuel.</li> <li>8. Blocked fuel line.</li> <li>9. Faulty spark plug(s).</li> <li>10. Engine flooded.</li> </ol>	<ol style="list-style-type: none"> <li>1. Place knob in disengaged (OFF) position.</li> <li>2. Engage parking brake.</li> <li>3. Move drive control levers fully outward in neutral position.</li> <li>4. Connect wire(s) to spark plug(s).</li> <li>5. Place throttle/choke lever to choke position.</li> <li>6. Push throttle/choke control lever to choke position.</li> <li>7. Fill tank with clean, fresh (less than 30 days old) gas.</li> <li>8. Clean fuel line and replace fuel filter.</li> <li>9. Clean, adjust gap or replace plug(s).</li> <li>10. Crank engine with throttle in FAST position.</li> </ol>
Engine runs erratic	<ol style="list-style-type: none"> <li>1. Tractor running with CHOKE activated.</li> <li>2. Spark plug wire(s) loose.</li> <li>3. Blocked fuel line or stale fuel.</li> <li>4. Vent in gas cap plugged.</li> <li>5. Water or dirt in fuel system.</li> <li>6. Dirty air cleaner.</li> </ol>	<ol style="list-style-type: none"> <li>1. Pull the throttle/choke control lever rearward from the choke position</li> <li>2. Connect spark plug wire(s).</li> <li>3. Clean fuel line; fill tank with clean, fresh gasoline and replace fuel filter.</li> <li>4. Clear vent or replace cap if damaged.</li> <li>5. Drain fuel tank. Refill with clean, fresh gasoline.</li> <li>6. Replace air cleaner paper element or clean foam pre-cleaner.</li> </ol>

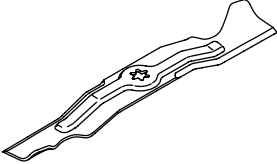
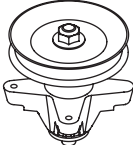
<b>Problem</b>	<b>Cause</b>	<b>Remedy</b>
Engine overheats	<ol style="list-style-type: none"> <li>1. Engine oil level low.</li> <li>2. Air flow restricted.</li> </ol>	<ol style="list-style-type: none"> <li>1. Fill crankcase with proper amount and weight of oil.</li> <li>2. Clean grass clippings and debris from around the engine's cooling fins and blower housing.</li> </ol>
Engine hesitates at high RPM	<ol style="list-style-type: none"> <li>1. Spark plug(s) gap too close.</li> </ol>	<ol style="list-style-type: none"> <li>1. Remove spark plug(s) and reset the gap.</li> </ol>
Engine Idles rough	<ol style="list-style-type: none"> <li>1. Spark plug(s) fouled, faulty or gap too wide.</li> <li>2. Dirty air cleaner.</li> </ol>	<ol style="list-style-type: none"> <li>1. Replace spark plug(s). Set plug gap.</li> <li>2. Replace air cleaner element and/or clean pre-cleaner.</li> </ol>
Excessive vibration	<ol style="list-style-type: none"> <li>1. Cutting blade loose or unbalanced.</li> <li>2. Damaged or bent cutting blade.</li> </ol>	<ol style="list-style-type: none"> <li>1. Tighten blade and spindle.</li> <li>2. Replace blade.</li> </ol>
Uneven cut	<ol style="list-style-type: none"> <li>1. Deck not leveled properly.</li> <li>2. Dull blade.</li> <li>3. Uneven tire pressure.</li> </ol>	<ol style="list-style-type: none"> <li>1. Perform side-to-side deck adjustment.</li> <li>2. Sharpen or replace blade.</li> <li>3. Check tire pressure in all four tires.</li> </ol>
Mower will not mulch grass (If Equipped w/Mulching Kit)	<ol style="list-style-type: none"> <li>1. Engine speed too low.</li> <li>2. Wet grass.</li> <li>3. Excessively high grass.</li> <li>4. Dull blade.</li> </ol>	<ol style="list-style-type: none"> <li>1. Place throttle/choke control lever in FAST (rabbit) position.</li> <li>2. Do not mulch when grass is wet.</li> <li>3. Mow once at a high cutting height, then mow again at desired height or make a narrower cutting swath.</li> <li>4. Sharpen or replace blade.</li> </ol>

Component	Part Number and Description
	759-3336 Spark Plug (RC12YC)
	BS-792105 Air Filter Element BS-792303 Foam Pre-cleaner
	BS-696854 Oil Filter
	BS-691035 Fuel Filter
	954-04044A Drive Belt (Mowing Deck)
	954-04043A Drive Belt (Transmissions)
	942-04053C 2-in-1 Deck Blade
	918-04125A Deck Spindle

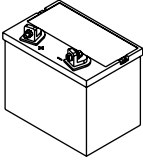
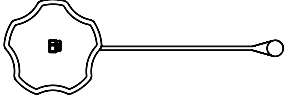
Phone (800) 965-4CUB to order replacement parts or a complete Parts Manual (have your full model number and serial number ready). Parts Manual downloads are also available free of charge at [www.cubcadet.com](http://www.cubcadet.com)

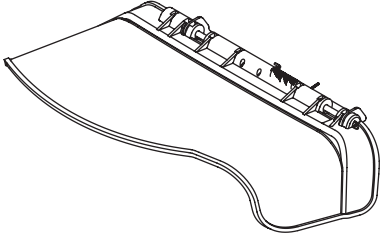
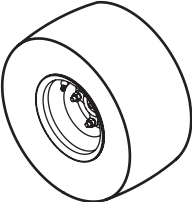
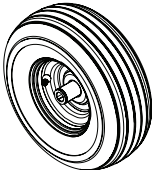
Component	Part Number and Description
	734-04155 Deck Wheel
	925-1707D Battery
	751-10703 Fuel Tank Cap
	746-04539 Throttle Control Cable
	925-1745 Ignition Key
	631-04070A Discharge Chute Assembly
	634-04128 Wheel Assembly
	634-04321A Caster Wheel Assembly

Phone (800) 965-4CUB to order replacement parts or a complete Parts Manual (have your full model number and serial number ready). Parts Manual downloads are also available free of charge at [www.cubcadet.com](http://www.cubcadet.com)

The following attachments and accessories are compatible with your Cub Cadet RZT tractor. See your Cub Cadet dealer or the retailer from which you purchased your tractor for information regarding price and availability.

Part Number	Part
19A70004100	Double Bagger
190-193-000	Mulch Plug
19A-115-100	Rear Bumper
19A-116-100	Rear Spreader
190-117-100	Sun Shade





---

**CALIFORNIA EMISSION CONTROL WARRANTY STATEMENT**  
**YOUR WARRANTY RIGHTS AND OBLIGATIONS**

The California Air Resources Board and MTD Consumer Group Inc are pleased to explain the evaporative emission control system warranty on your 2008 lawn mower. In California, new lawn mowers must be designed, built and equipped to meet the State's stringent anti-smog standards. MTD Consumer Group Inc must warrant the EECS on your lawn mower for the period of time listed below provided there has been no abuse, neglect or improper maintenance of your lawn mower.

Your EECS may include parts such as the carburetor, fuel-injection system, the ignition system, catalytic converter, fuel tanks, fuel lines, fuel caps, valves, canisters, filters, vapor hoses, clamps, connectors, and other associated emission-related components.

**Where a warrantable condition exists, MTD Consumer Group Inc will repair your lawn mower at no cost to you including diagnosis, parts and labor.**

**MANUFACTURER'S WARRANTY COVERAGE:**

This evaporative emission control system is warranted for two years. If any evaporative emission-related part on your equipment is defective, the part will be repaired or replaced by MTD Consumer Group Inc.

**OWNER'S WARRANTY RESPONSIBILITIES:**

As the lawn mower owner, you are responsible for performance of the required maintenance listed in your owner's manual. MTD Consumer Group Inc recommends that you retain all receipts covering maintenance on your lawn mower, but MTD Consumer Group Inc cannot deny warranty solely for the lack of receipts.

As the lawn mower owner, you should however be aware that MTD Consumer Group Inc may deny you warranty coverage if your lawn mower or a part has failed due to abuse, neglect, or improper maintenance or unapproved modifications.

You are responsible for presenting your lawn mower to MTD Consumer Group Inc's distribution center or service center as soon as the problem exists. The warranty repairs should be completed in a reasonable amount of time, not to exceed 30 days. If you have a question regarding your warranty coverage, you should contact the MTD Consumer Group Inc Service Department at 1-800-800-7310.

**GENERAL EMISSIONS WARRANTY COVERAGE:**

MTD Consumer Group Inc warrants to the ultimate purchaser and each subsequent purchaser that the lawn mower is: Designed, built and equipped so as to conform with all applicable regulations; and free from defects in materials and workmanship that cause the failure of a warranted part to be identical in all material respects to that part as described in MTD Consumer Group Inc's application for certification.

The warranty period begins on the date the lawn mower is delivered to an ultimate purchaser or first placed into service. The warranty period is two years.

Subject to certain conditions and exclusions as stated below, the warranty on emission-related parts is as follows:

1. Any warranted part that is not scheduled for replacement as required maintenance in the written instructions supplied, is warranted for the warranty period stated above. If the part fails during the period of warranty coverage, the part will be repaired or replaced by MTD Consumer Group Inc according to subsection (4) below. Any such part repaired or replaced under warranty will be warranted for the remainder of the period.
  2. Any warranted part that is scheduled only for regular inspection in the written instructions supplied is warranted for the warranty period stated above. Any such part repaired or replaced under warranty will be warranted for the remaining warranty period.
  3. Any warranted part that is scheduled for replacement as required maintenance in the written instructions supplied is warranted for the period of time before the first scheduled replacement date for that part. If the part fails before the first scheduled replacement, the part will be repaired or replaced by MTD Consumer Group Inc according to subsection (4) below. Any such part repaired or replaced under warranty will be warranted for the remainder of the period prior to the first scheduled replacement point for the part.
  4. Repair or replacement of any warranted part under the warranty provisions herein must be performed at a warranty station at no charge to the owner.
  5. Notwithstanding the provisions herein, warranty services or repairs will be provided at all of our distribution centers that are franchised to service the subject engines or equipment.
  6. The lawn mower owner will not be charged for diagnostic labor that is directly associated with diagnosis of a defective, emission-related warranted part, provided that such diagnostic work is performed at a warranty station.
  7. MTD Consumer Group Inc is liable for damages to other engine or equipment components proximately caused by a failure under warranty of any warranted part.
  8. Throughout the lawn mower warranty period stated above, MTD Consumer Group Inc will maintain a supply of warranted parts sufficient to meet the expected demand for such parts.
  9. Any replacement part may be used in the performance of any warranty maintenance or repairs and must be provided without charge to the owner. Such use will not reduce the warranty obligations of MTD Consumer Group Inc.
  10. Add-on or modified parts that are not exempted by the Air Resources Board may not be used. The use of any non-exempted add-on or modified parts by the ultimate purchaser will be grounds for disallowing a warranty claims. MTD Consumer Group Inc will not be liable to warrant failures of warranted parts caused by the use of a non-exempted add-on or modified part.
-

---

### **WARRANTED PARTS:**

The repair or replacement of any warranted part otherwise eligible for warranty coverage may be excluded from such warranty coverage if MTD Consumer Group Inc demonstrates that the lawn mower has been abused, neglected, or improperly maintained, and that such abuse, neglect, or improper maintenance was the direct cause of the need for repair or replacement of the part. That notwithstanding, any adjustment of a component that has a factory installed, and properly operating, adjustment limiting device is still eligible for warranty coverage. The following emission warranty parts are covered:

(1) Fuel Metering System

- Cold start enrichment system (soft choke)
- Carburetor and internal parts
- Fuel pump
- Fuel tank

(2) Air Induction System

- Air cleaner
- Intake manifold

(3) Ignition System

- Spark plug(s)
- Magneto ignition system

(4) Exhaust System

- Catalytic converter
- SAI (Reed valve)

(5) Miscellaneous Items Used in Above System

- Vacuum, temperature, position, time sensitive valves and switches
- Connectors and assemblies

(6) Evaporative Control

- Fuel hose certified for ARB evaporative emissions 2008
- Fuel hose clamps
- Tethered fuel cap
- Carbon canister
- Vapor lines

# CUB CADET LLC

## MANUFACTURER'S LIMITED WARRANTY FOR RESIDENTIAL ZERO-TURN ("RZT") MOWERS

**IMPORTANT:** To obtain warranty coverage owner must present an original proof of purchase and applicable maintenance records to the servicing dealer. Please see the operator's manual for information on required maintenance and service intervals.

The limited warranty set forth below is given by Cub Cadet LLC with respect to new merchandise purchased or leased and used in the United States and/or its territories and possessions, and by MTD Products Limited with respect to new merchandise purchased or leased and used in Canada and/or its territories and possessions (either entity respectively, "Cub Cadet").

Cub Cadet warrants this product (excluding its *Normal Wear Parts, Batteries and Attachments* as described below) against defects in material and workmanship for a period of three (3) years or one hundred twenty (120) operation hours, whichever comes first, commencing on the date of original retail purchase or lease and will, at its option, repair or replace, free of charge, any part found to be defective in materials or workmanship.

*Normal Wear Parts* are warranted to be free from defects in material and workmanship for a period of thirty (30) days from the date of original purchase or lease. Normal wear parts include, but are not limited to items such as: belts, blades, blade adapters, grass bags, rider deck wheels, seats, and tires.

*Batteries* have a one-year prorated limited warranty against defects in material and workmanship, with 100% replacement during the first three months. After three months, the battery replacement credit is based on the months remaining in the twelve (12) month period dating back to the original date of original sale or lease. Any replacement battery will be warranted only for the remainder of the original warranty period.

*Attachments* — Cub Cadet warrants attachments for this product against defects in material and workmanship for a period of one (1) year, commencing on the date of the attachment's original purchase or lease. Attachments include, but are not limited to items such as: grass collectors and mulch kits.

This limited warranty shall only apply if this product has been operated and maintained in accordance with the Operator's Manual furnished with the product, and has not been subject to misuse, abuse, neglect, accident, improper maintenance, alteration, vandalism, theft, fire, water, or damage because of other peril or natural disaster. Damage resulting from the installation or use of any part, accessory or attachment not approved by Cub Cadet for use with the product(s) covered by this manual will void your warranty as to any resulting damage. In addition, Cub Cadet may deny warranty coverage if the hour meter, or any part thereof, is altered, modified, disconnected or otherwise tampered with.

**HOW TO OBTAIN SERVICE:** Warranty service is available, WITH PROOF OF PURCHASE AND APPLICABLE MAINTENANCE RECORDS, through your local authorized service dealer. To locate the dealer in your area:

### In the U.S.A.:

Check your Yellow Pages, or contact Cub Cadet LLC at P.O. Box 361131, Cleveland, Ohio 44136-0019, call 1-877-282- 8684 or log on to our website at [www.cubcadet.com](http://www.cubcadet.com).

### In Canada:

Contact MTD Products Limited, Kitchener, ON N2G 4J1, call 1-800-668-1238 or log on to our website at [www.mtdcanada.com](http://www.mtdcanada.com).

Without limiting the foregoing, this limited warranty does not provide coverage in the following cases:

- a. Routine maintenance items such as lubricants, filters, blade sharpening, tune-ups, brake adjustments, clutch adjustments, deck adjustments, and normal deterioration of the exterior finish due to use or exposure.
- b. Service completed by someone other than an authorized service dealer.
- c. Cub Cadet does not extend any warranty for products sold or exported outside of the United States and/or Canada, and their respective possessions and territories, except those sold through Cub Cadet's authorized channels of export distribution.
- d. Replacement parts and/or accessories that are not genuine Cub Cadet parts.
- e. Transportation charges and service calls.

**There are no implied warranties, including without limitation any implied warranty of merchantability or fitness for a particular purpose. No warranties shall apply after the applicable period of express written warranty above. No other express warranties beyond those mentioned above, given by any person or entity, including a dealer or retailer, with respect to any product, shall bind Cub Cadet. The exclusive remedy is repair or replacement of the product as set forth above. The terms of this warranty provide the sole and exclusive remedy arising from the sale and/or lease of the products covered hereby. Cub Cadet shall not be liable for any incidental or consequential loss or damage including, without limitation, expenses incurred for substitute or replacement lawn care services or for rental expenses to temporarily replace a warranted product.**

Some jurisdictions do not allow the exclusion or limitation of incidental or consequential damages, or limitations on how long an implied warranty lasts, so the above exclusions or limitations may not apply to you.

In no event shall recovery of any kind be greater than the amount of the purchase price of the product sold. **Alteration of safety features of the product shall void this warranty.** You assume the risk and liability for loss, damage, or injury to you and your property and/or to others and their property arising out of the misuse or inability to use the product.

This limited warranty shall not extend to anyone other than the original purchaser or to the person for whom it was purchased as a gift.

**HOW LOCAL LAWS RELATE TO THIS WARRANTY:** This limited warranty gives you specific legal rights, and you may also have other rights that vary in different jurisdictions.

**Cub Cadet LLC, P.O. BOX 361131 CLEVELAND, OHIO 44136-0019, Phone: 1-877-282-8684**  
**MTD Products Limited, Kitchener, ON N2G 4J1, Phone: 1-800-668-1238**