

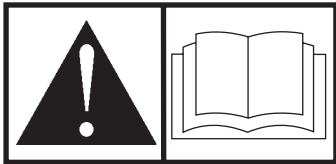

6200 Watt Portable Generator Operator's Manual



BRIGGS & STRATTON POWER PRODUCTS GROUP, LLC
JEFFERSON, WISCONSIN, U.S.A.



Printed in U.S.A. Manual No. 197523GS Revision D (06/05/2007)

Thank you for purchasing this quality-built Briggs & Stratton generator. We are pleased that you've placed your confidence in the Briggs & Stratton brand. When operated and maintained according to the instructions in this manual, your Briggs & Stratton generator will provide many years of dependable service.

This manual contains safety information to make you aware of the hazards and risks associated with generator products and how to avoid them. This generator is designed and intended only for supplying electrical power for operating compatible electrical lighting, appliances, tools and motor loads, and is not intended for any other purpose. It is important that you read and understand these instructions thoroughly before attempting to start or operate this equipment. **Save these instructions for future reference.**

This generator requires final assembly before use. Refer to the *Assembly* section of this manual for instructions on final assembly procedures. Follow the instructions completely.

Where to Find Us

You never have to look far to find Briggs & Stratton support and service for your generator. Consult your Yellow Pages. There are over 30,000 Briggs & Stratton authorized service dealers worldwide who provide quality service. You can also contact Briggs & Stratton Customer Service by phone at **(800) 743-4115** or on the Internet at BRIGGSandSTRATTON.COM.

Generator

Model Number

--	--	--	--	--	--

Revision

--	--

Serial Number

--	--	--	--	--	--	--	--	--	--

Engine

Model Number

--	--	--	--	--	--

Type Number

--	--	--	--	--	--

Code Number

--	--	--	--	--	--	--	--	--	--	--	--

Date Purchased

--	--	--	--	--	--

Briggs & Stratton Power Products Group, LLC
900 North Parkway
Jefferson, WI 53549

Copyright © 2007 Briggs & Stratton Power Products Group, LLC. All rights reserved. No part of this material may be reproduced or transmitted in any form by any means without the express written permission of Briggs & Stratton Power Products Group, LLC.

Table of Contents

Operator Safety	4
Equipment Description	4
Safety Rules	4
Assembly	7
Unpack Generator	7
Install Wheel Kit	7
Add Engine Oil	8
Add Fuel	8
Attach Negative Battery Cable	8
System Ground	9
Connecting to a Building's Electrical System	9
Generator Location	9
Features and Controls	10
Cord Sets and Receptacles	11
Battery Float Charger	12
Operation	13
Starting the Engine	13
Connecting Electrical Loads	14
Stopping the Engine	14
Don't Overload Generator	15
Maintenance	16
Maintenance Schedule	16
Generator Maintenance	16
Battery Maintenance	17
Engine Maintenance	17
Storage	20
Troubleshooting	21
Warranties	22
Emissions Control System Warranty	22
Generator Owner Warranty	24
Specifications	26
Product Specifications	26
Common Service Parts	26

Safety

Assembly

Controls

Operation

Maintenance

Troubleshooting

Warranty

Operator Safety

Equipment Description



Read this manual carefully and become familiar with your generator. Know its applications, its limitations and any hazards involved.

The generator is an engine-driven, revolving field, alternating current (AC) generator. It was designed to supply electrical power for operating compatible electrical lighting, appliances, tools and motor loads. The generator's revolving field is driven at about 3,600 rpm by a single-cylinder engine.

NOTICE

Exceeding generators wattage/amperage capacity can damage generator and/or electrical devices connected to it.

- DO NOT exceed the generator's wattage/amperage capacity. See *Don't Overload Generator* in the *Operation* section.

Every effort has been made to ensure that the information in this manual is both accurate and current. However, the manufacturer reserves the right to change, alter or otherwise improve the generator and this documentation at any time without prior notice.

The Emission Control System for this generator is warranted for standards set by the Environmental Protection Agency and the California Air Resources Board.

Safety Rules



This is the safety alert symbol. It is used to alert you to potential personal injury hazards. Obey all safety messages that follow this symbol to avoid possible injury or death.

The safety alert symbol (▲) is used with a signal word (**DANGER**, **WARNING**, **CAUTION**), a pictorial and/or a safety message to alert you to hazards. **DANGER** indicates a hazard which, if not avoided, will result in death or serious injury. **WARNING** indicates a hazard which, if not avoided, could result in death or serious injury. **CAUTION** indicates a hazard which, if not avoided, might result in minor or moderate injury. **NOTICE** indicates a situation that could result in equipment damage. Follow safety messages to avoid or reduce the risk of injury or death.

The manufacturer cannot possibly anticipate every possible circumstance that might involve a hazard. The warnings in this manual, and the tags and decals affixed to the unit are, therefore, not all-inclusive. If you use a procedure, work method or operating technique that the manufacturer does not specifically recommend, you must satisfy yourself that it is safe for you and others. You must also make sure that the procedure, work method or operating technique that you choose does not render the generator unsafe.

Hazard Symbols and Meanings

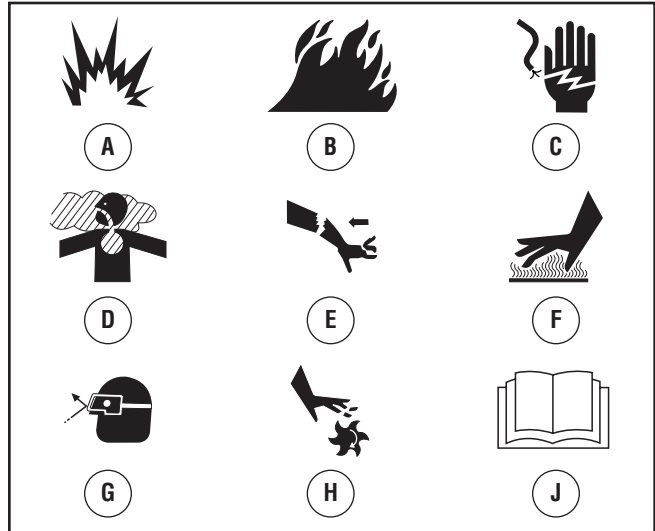

- A - Explosion
- B - Fire
- C - Electric Shock
- D - Toxic Fumes
- E - Kickback
- F - Hot Surface
- G - Flying Objects
- H - Moving Parts
- J - Read Manual

▲ DANGER

Using a generator indoors CAN KILL YOU IN MINUTES.

Generator exhaust contains carbon monoxide. This is a poison you cannot see or smell.

NEVER use inside a home or garage, **EVEN IF** doors and windows are open.

Only use **OUTSIDE** and far away from windows, doors, and vents.

▲ WARNING

Running engine gives off carbon monoxide, an odorless, colorless, poison gas.

Breathing carbon monoxide can cause headache, fatigue, dizziness, vomiting, confusion, seizures, nausea, fainting or death.

- Operate generator **ONLY** outdoors.
- Install a battery operated carbon monoxide alarm near the bedrooms.
- Keep exhaust gas from entering a confined area through windows, doors, ventilation intakes, or other openings.
- **DO NOT** start or run engine indoors or in an enclosed area, (even if windows and doors are open), including the generator compartment of a recreational vehicle (RV).

⚠ WARNING

The engine exhaust from this product contains chemicals known to the State of California to cause cancer, birth defects, or other reproductive harm.

⚠ WARNING

	<p>Generator produces hazardous voltage.</p> <p>Failure to isolate generator from power utility can result in death or injury to electric utility workers due to backfeed of electrical energy.</p>
---	---



- When using generator for backup power, notify utility company. Use approved transfer equipment to isolate generator from electric utility.
- Use a ground fault circuit interrupter (GFCI) in any damp or highly conductive area, such as metal decking or steel work.
- DO NOT touch bare wires or receptacles.
- DO NOT use generator with electrical cords which are worn, frayed, bare or otherwise damaged.
- DO NOT operate generator in the rain or wet weather.
- DO NOT handle generator or electrical cords while standing in water, while barefoot, or while hands or feet are wet.
- DO NOT allow unqualified persons or children to operate or service generator.

⚠ WARNING

	<p>Starter cord kickback (rapid retraction) can result in bodily injury. Kickback will pull hand and arm toward engine faster than you can let go.</p> <p>Broken bones, fractures, bruises, or sprains could result.</p>
---	--

- When starting engine, pull cord slowly until resistance is felt and then pull rapidly to avoid kickback.
- NEVER start or stop engine with electrical devices plugged in and turned on.

⚠ WARNING

	Fuel and its vapors are extremely flammable and explosive.
	Fire or explosion can cause severe burns or death.

WHEN ADDING OR DRAINING FUEL

- Turn generator OFF and let it cool at least 2 minutes before removing fuel cap. Loosen cap slowly to relieve pressure in tank.
- Fill or drain fuel tank outdoors.
- DO NOT overfill tank. Allow space for fuel expansion.
- If fuel spills, wait until it evaporates before starting engine.
- Keep fuel away from sparks, open flames, pilot lights, heat, and other ignition sources.
- DO NOT light a cigarette or smoke.

WHEN STARTING EQUIPMENT

- Ensure spark plug, muffler, fuel cap, and air cleaner are in place.
- DO NOT crank engine with spark plug removed.

WHEN OPERATING EQUIPMENT

- DO NOT tip engine or equipment at angle which causes fuel to spill.
- This generator is not for use in mobile equipment or marine applications.

WHEN TRANSPORTING OR REPAIRING EQUIPMENT



- Transport/repair with fuel tank EMPTY or with fuel shutoff valve OFF.
- Disconnect spark plug wire.

WHEN STORING FUEL OR EQUIPMENT WITH FUEL IN TANK



- Store away from furnaces, stoves, water heaters, clothes dryers, or other appliances that have pilot light or other ignition source because they can ignite fuel vapors.

⚠ WARNING

- This generator does not meet U. S. Coast Guard Regulation 33CFR-183 and should not be used on marine applications.
- Failure to use the appropriate U. S. Coast Guard approved generator could result in death or serious injury and/or property damage.

 WARNING	
	Contact with muffler area can result in serious burns.
	Exhaust heat/gases can ignite combustibles, structures or damage fuel tank causing a fire.
<ul style="list-style-type: none"> • DO NOT touch hot parts and AVOID hot exhaust gases. • Allow equipment to cool before touching. • Keep at least 5 feet (1.5 m) of clearance on all sides of generator including overhead. • Code of Federal Regulation (CFR) Title 36 Parks, Forests, and Public Property require equipment powered by an internal combustion engine to have a spark arrester, maintained in effective working order, complying to USDA Forest service standard 5100-1C or later revision. In the State of California a spark arrester is required under section 4442 of the California Public resources code. Other states may have similar laws. 	

 WARNING	
	Starter and other rotating parts can entangle hands, hair, clothing, or accessories.
<ul style="list-style-type: none"> • NEVER operate generator without protective housing or covers. • DO NOT wear loose clothing, jewelry or anything that may be caught in the starter or other rotating parts. • Tie up long hair and remove jewelry. 	

 WARNING	
	Unintentional sparking can result in fire or electric shock.
<p>WHEN ADJUSTING OR MAKING REPAIRS TO YOUR GENERATOR</p> <ul style="list-style-type: none"> • Disconnect the spark plug wire from the spark plug and place the wire where it cannot contact spark plug. <p>WHEN TESTING FOR ENGINE SPARK</p> <ul style="list-style-type: none"> • Use approved spark plug tester. • DO NOT check for spark with spark plug removed. 	

 CAUTION	
Excessively high operating speeds increase risk of injury and damage to generator.	
Excessively low speeds impose a heavy load.	
<ul style="list-style-type: none"> • DO NOT tamper with governed speed. Generator supplies correct rated frequency and voltage when running at governed speed. • DO NOT modify generator in any way. 	

NOTICE	
Exceeding generators wattage/amperage capacity can damage generator and/or electrical devices connected to it.	
<ul style="list-style-type: none"> • DO NOT exceed the generator's wattage/amperage capacity. See <i>Don't Overload Generator</i> in the <i>Operation</i> section. • Start generator and let engine stabilize before connecting electrical loads. • Connect electrical loads in OFF position, then turn ON for operation. • Turn electrical loads OFF and disconnect from generator before stopping generator. 	

NOTICE	
Improper treatment of generator can damage it and shorten its life.	
<ul style="list-style-type: none"> • Use generator only for intended uses. • If you have questions about intended use, ask dealer or contact local service center. • Operate generator only on level surfaces. • DO NOT expose generator to excessive moisture, dust, dirt, or corrosive vapors. • DO NOT insert any objects through cooling slots. • If connected devices overheat, turn them off and disconnect them from generator. • Shut off generator if: <ul style="list-style-type: none"> -electrical output is lost; -equipment sparks, smokes, or emits flames; -unit vibrates excessively. 	

Assembly

Your generator requires some assembly and is ready for use after it has been properly serviced with the recommended fuel and oil.

If you have any problems with the assembly of your generator, please call the generator helpline at **(800) 743-4115**. If calling for assistance, please have the model, revision, and serial number from the data tag available. See *Generator Controls and Features* for data tag location.

Unpack Generator

1. Set the carton on a rigid, flat surface.
2. Remove everything from carton except generator.
3. Open carton completely by cutting each corner from top to bottom.
4. Leave generator on carton to install wheel kit.

The generator is supplied with:

- Operator's manual
- Battery float charger
- Oil bottle
- Wheel kit

Install Wheel Kit

NOTE: Wheel kit is not intended for over-the-road use.

You will need the following tools to install these components:

- 7/16" and 13 mm wrenches
- Socket wrench with 7/16" and 13 mm sockets
- Pliers
- Safety glasses

Install the wheel kit as follows:

1. Tip generator so that engine end is up.
2. Slide axle (A) through both mounting brackets.
3. Place a wheel (B) on each side as shown below.
4. Place a washer (C) on axle and then place an e-ring (D) in axle groove.

 CAUTION	
	E-rings can cause eye injury.
	E-rings can spring back and become airborne when installing or removing.
• Always wear eye protection when installing/removing e-rings.	

5. Install e-ring with pliers, squeezing from top of e-ring to bottom of axle.
6. Repeat steps 4 and 5 to secure second wheel.
7. Tip generator so that engine side is down.
8. Attach the vibration mounts (E) to the support leg (F) with 1/4-20 x 1" capscrews (G) and 1/4-20 lock nuts (H).
9. Remove existing locknut from left unit vibration mount with 13mm wrench. Use same locknut to attach support leg.
10. Attach other side of support leg with a M8 x 20 mm capscrew (J) and M8 lock nut (K).
11. Return generator to normal operating position (resting on wheels and support leg).

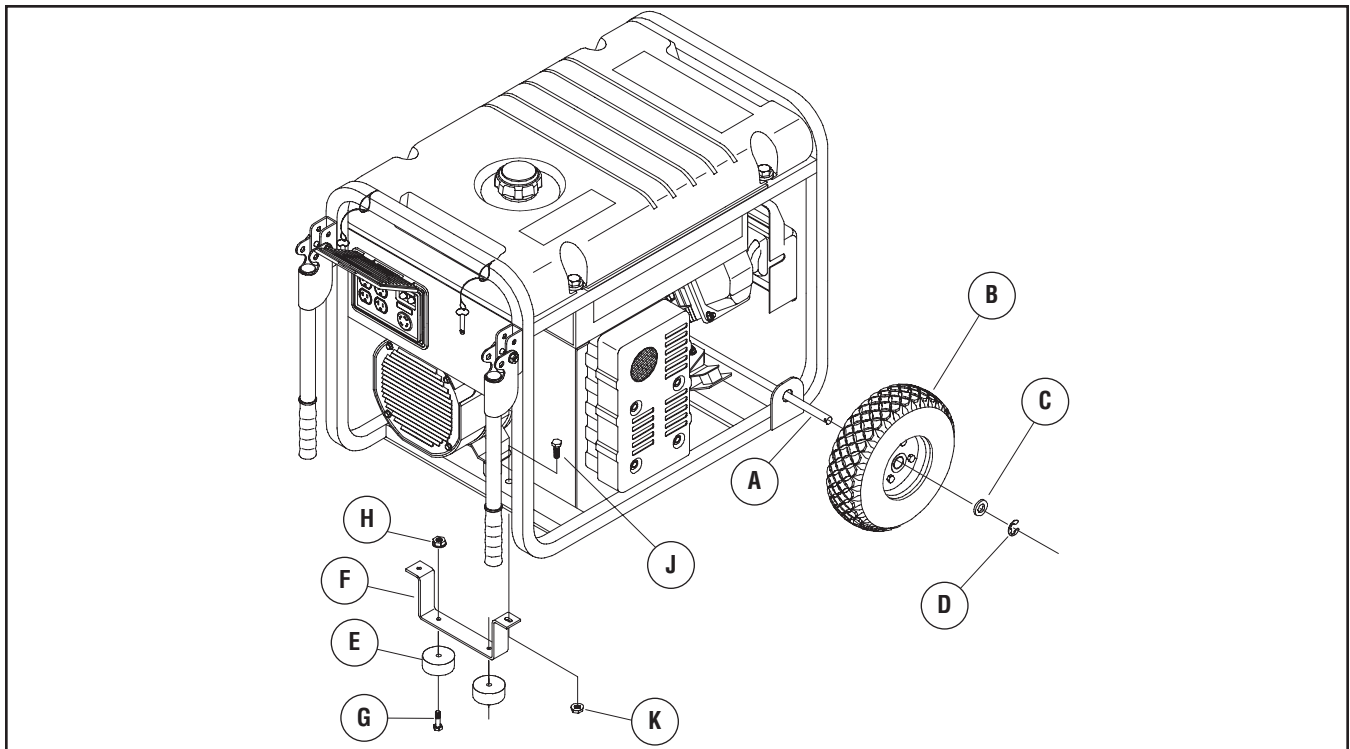

Add Engine Oil

1. Place generator on a flat, level surface.
2. Clean area around oil fill and remove yellow oil fill cap.

NOTE: See the section *Oil* to review oil recommendations. Verify provided oil bottle is correct viscosity for current ambient temperature.

3. Using oil funnel (optional), slowly pour contents of provided oil bottle into oil fill opening.

NOTICE	
Improper treatment of generator can damage it and shorten its life.	
<ul style="list-style-type: none"> • DO NOT attempt to crank or start the engine before it has been properly serviced with the recommended oil. This may result in an engine failure. 	

4. Replace oil fill cap and fully tighten.



Add Fuel

Fuel must meet these requirements:

- Clean, fresh, unleaded gasoline.
- A minimum of 87 octane/87 AKI (91 RON). High altitude use, see *High Altitude*.
- Gasoline with up to 10% ethanol (gasohol) or up to 15% MTBE (methyl tertiary butyl ether) is acceptable.

NOTICE	
Avoid generator damage.	
Failure to follow Operator's Manual for fuel recommendations voids warranty.	
<ul style="list-style-type: none"> • DO NOT use unapproved gasoline such as E85. • DO NOT mix oil in gasoline. • DO NOT modify engine to run on alternate fuels. 	

To protect the fuel system from gum formation, mix in a fuel stabilizer when adding fuel. See *Storage*. All fuel is not the same. If you experience starting or performance problems after using fuel, switch to a different fuel provider or change brands. This engine is certified to operate on gasoline. The emission control system for this engine is EM (Engine Modifications).

 WARNING	
	Fuel and its vapors are extremely flammable and explosive.
	Fire or explosion can cause severe burns or death.
WHEN ADDING FUEL	
<ul style="list-style-type: none"> • Turn generator OFF and let it cool at least 2 minutes before removing fuel cap. Loosen cap slowly to relieve pressure in tank. • Fill fuel tank outdoors. • DO NOT overfill tank. Allow space for fuel expansion. • If fuel spills, wait until it evaporates before starting engine. • Keep fuel away from sparks, open flames, pilot lights, heat, and other ignition sources. • DO NOT light a cigarette or smoke. 	

1. Clean area around fuel fill cap, remove cap.
2. Slowly add unleaded gasoline (A) to fuel tank (B). Be careful not to overfill. Allow about 1.5" (4 cm) of tank space (C) for fuel expansion.

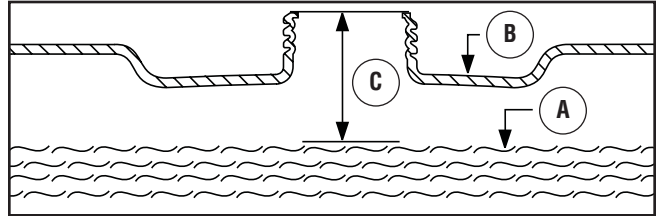

3. Install fuel cap and let any spilled fuel evaporate before starting engine.

High Altitude

At altitudes over 5,000 feet (1524 meters), a minimum 85 octane / 85 AKI (89 RON) gasoline is acceptable. To remain emissions compliant, high altitude adjustment is required. Operation without this adjustment will cause decreased performance, increased fuel consumption, and increased emissions. See an authorized dealer for high altitude adjustment information. Operation of the engine at altitudes below 2,500 feet (762 meters) with the high altitude kit is not recommended.

Attach Negative Battery Cable

Your unit is equipped with electric start capability, but can be started manually. If you choose not to use the electric start feature, you do not need to connect the negative battery cable.

The sealed battery on the generator pre-installed except for the negative (black) battery cable.

To install:

1. Cut off tie wrap securing loose end of negative (black) cable.
2. Remove screw (D), lock washer (E) and flat washer (F) on negative battery terminal.

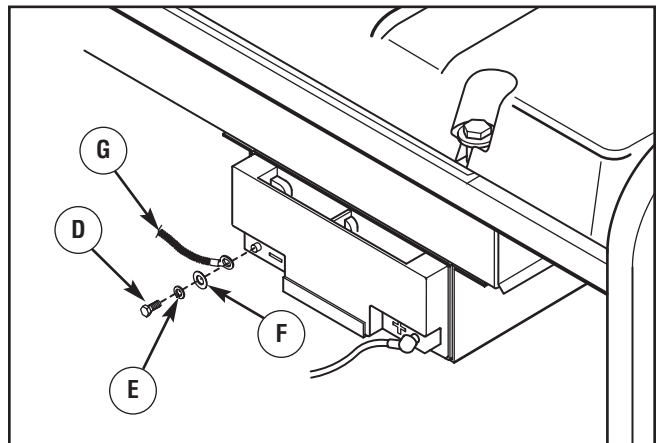

3. Slide lock washer, flat washer and negative battery cable (G) over screw.
4. Reattach screw to negative battery terminal and tighten.

- Verify that connections to battery and generator are tight and secure.

NOTE: Charge prior to use following the instructions in the section *Battery Float Charger*.

System Ground

The generator has a system ground that connects the generator frame components to the ground terminals on the AC output receptacles. The system ground is connected to the AC neutral wire (the neutral is bonded to the generator frame).

Special Requirements

There may be Federal or State Occupational Safety and Health Administration (OSHA) regulations, local codes, or ordinances that apply to the intended use of the generator. Please consult a qualified electrician, electrical inspector, or the local agency having jurisdiction:

- In some areas, generators are required to be registered with local utility companies.
- If the generator is used at a construction site, there may be additional regulations which must be observed.

Connecting to a Building's Electrical System

Connections for standby power to a building's electrical system must be made by a qualified electrician. The connection must isolate the generator power from utility power or other alternative power sources and must comply with all applicable laws and electrical codes.

⚠ WARNING	
	Generator produces hazardous voltage. Failure to isolate generator from power utility can result in death or injury to electric utility workers due to backfeed of electrical energy.
<ul style="list-style-type: none"> When using generator for backup power, notify utility company. Use approved transfer equipment to isolate generator from electric utility. Use a ground fault circuit interrupter (GFCI) in any damp or highly conductive area, such as metal decking or steel work. DO NOT touch bare wires or receptacles. DO NOT use generator with electrical cords which are worn, frayed, bare or otherwise damaged. DO NOT operate generator in the rain or wet weather. DO NOT handle generator or electrical cords while standing in water, while barefoot, or while hands or feet are wet. DO NOT allow unqualified persons or children to operate or service generator. 	

Generator Location

Clearances and Air Movement

⚠ WARNING	
	Exhaust heat/gases can ignite combustibles, structures or damage fuel tank causing a fire.
<ul style="list-style-type: none"> Keep at least 5 ft. (1.5 m) clearance on all sides of generator including overhead. 	

Place generator outdoors in an area that will not accumulate deadly exhaust gas. DO NOT place generator where exhaust gas (A) could accumulate and enter inside or be drawn into a potentially occupied building. Ensure exhaust gas is kept away from any windows, doors, ventilation intakes, or other openings that can allow exhaust gas to collect in a confined area. Prevailing winds and air currents should be taken into consideration when positioning generator.

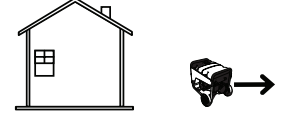
⚠ DANGER	
Using a generator indoors CAN KILL YOU IN MINUTES. Generator exhaust contains carbon monoxide. This is a poison you cannot see or smell.	
 NEVER use inside a home or garage, EVEN IF doors and windows are open.	 Only use OUTSIDE and far away from windows, doors, and vents.

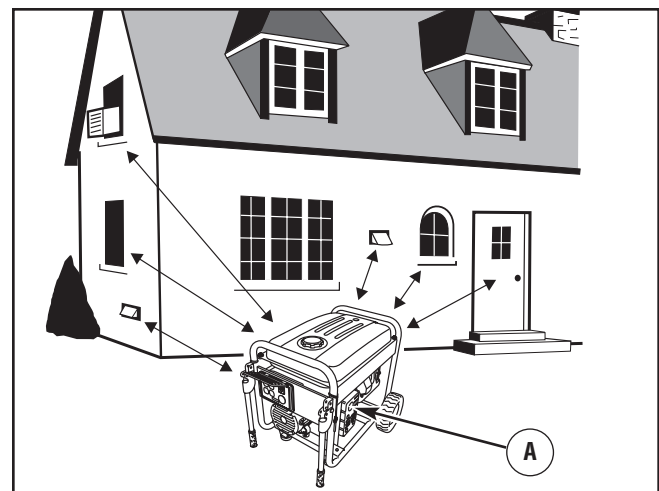

Features and Controls



Read this Operator's Manual and safety rules before operating your generator.

Compare the illustrations with your generator, to familiarize yourself with the locations of various controls and adjustments. Save this manual for future reference.

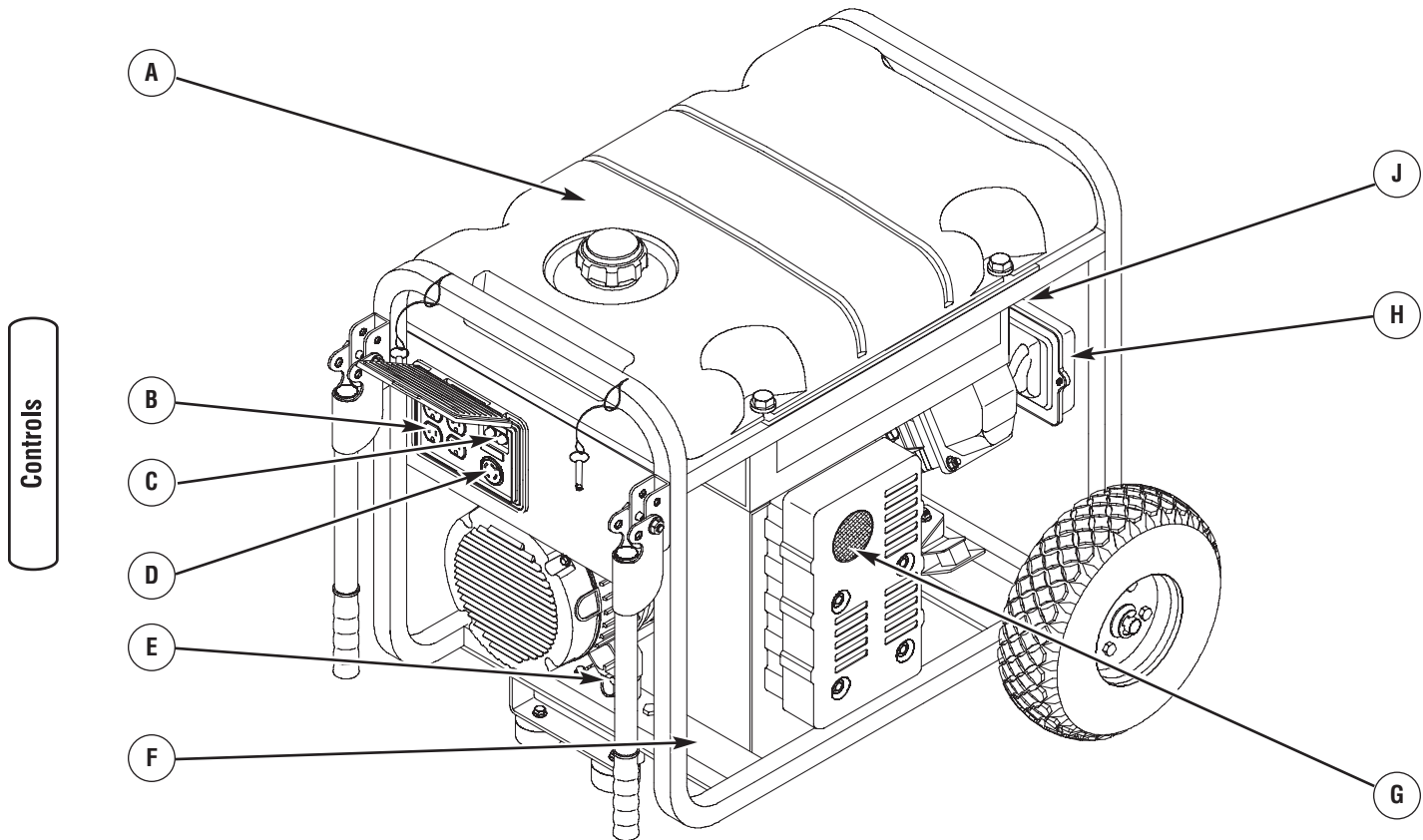

A - Fuel Tank — Capacity of seven (7) U.S. gallons (26.5 L).

B - 120 Volt AC, 20 Amp, Duplex Receptacles — May be used to supply electrical power for the operation of 120 Volt AC, 20 Amp, single phase, 60 Hz electrical, lighting, appliance, tool, and motor loads.

C - Circuit Breakers (AC) — Push-to-reset circuit breakers are provided to protect generator against electrical overload.

D - 120/240 Volt AC, 30 Amp Locking Receptacle — May be used to supply electrical power for the operation of 120 and/or 240 Volt AC, 30 Amp, single phase, 60 Hz electrical, lighting, appliance, tool and motor loads.

E - Grounding Fastener — Consult your local agency having jurisdiction for grounding requirements in your area.

F - Data Tag — Provides model, revision, and serial number of generator. Please have these readily available when calling for assistance.

G - Spark Arrester Muffler — Exhaust muffler lowers engine noise and is equipped with a spark arrester screen.

H - Air Cleaner — Protects engine by filtering dust and debris out of intake air.

J - Choke Lever — Used when starting a cold engine.

Items Not Shown:

Battery Float Charger Jack — Use battery float charger to keep the starting battery charged and ready for use.

Engine Identification — Provides model, type and code of engine. Please have these readily available if calling for assistance.

Engine Rocker Switch — Set this switch to “On” before using recoil starter. Set switch to “Off” to stop engine.

Fuel Valve — Used to turn fuel supply on and off to engine.

Oil Drain Plug — Drain engine oil here.

Oil Fill Cap — Check and fill engine with oil here.

Recoil Starter — Used to start the engine.



Start Button — Push and hold in start position for a maximum of 15 seconds during each start attempt, until engine starts.

Cord Sets and Receptacles

Use only high quality, well-insulated, grounded extension cords with the generator's 120 Volt duplex receptacle. Inspect extension cords before each use.

Check the ratings of all extension cords before you use them. Extension cord sets used should be rated for 125 Volt AC loads at 20 Amps or greater for most electrical devices. Some devices, however, may not require this type of extension cord. Check the operator's manuals of those devices for the manufacturer's recommendations.

Keep extension cords as short as possible to minimize voltage drop.

 WARNING	
	Overloaded electrical cords can overheat, arc, and burn resulting in death, bodily injury, and/or property damage.
<ul style="list-style-type: none"> • ONLY use cords rated for your loads. • Follow all safeties on electrical cords. 	

120/240 Volt AC, 30 Amp, Locking Receptacle

Use a NEMA L14-30 plug with this receptacle. Connect a 4-wire cord set rated for 250 Volt AC loads at 30 Amps (or greater). You can use the same 4-wire cord if you plan to run a 120 Volt load.

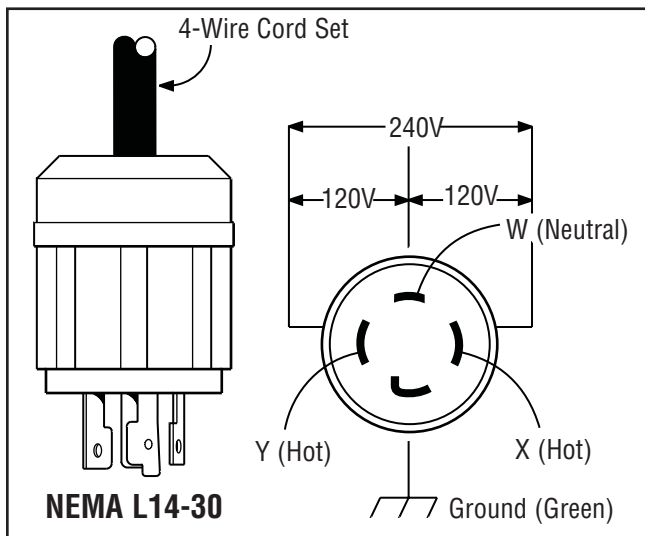

This receptacle powers 120/240 Volt AC, 60 Hz, single phase loads requiring up to 6,200 watts of power (6.2 kW) at 25.8 Amps for 240 Volts or two independent 120 Volt loads at 25.8 Amps each. The outlet is protected by a push-to-reset circuit breaker.

NOTICE
Receptacles may be marked with rating value greater than generator output capacity.
<ul style="list-style-type: none"> • NEVER attempt to power a device requiring more amperage than generator or receptacle can supply. • DO NOT overload the generator. See <i>Don't Overload Generator</i>.

120 Volt AC, 20 Amp, Duplex Receptacles

Both duplex receptacles are protected against overload by a push-to-reset circuit breaker.

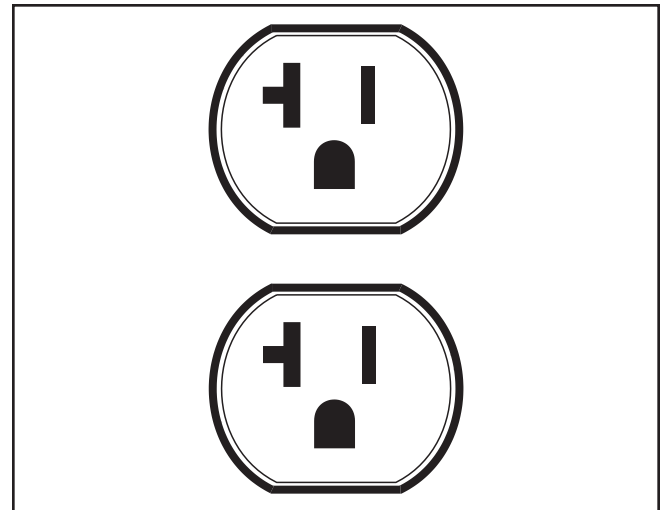

Use each receptacle to operate 120 Volt AC, single-phase, 60 Hz electrical loads requiring up to 2,400 watts (2.4 kW) at 20 Amps of current. Use cord sets that are rated for 125 Volt AC loads at 20 Amps (or greater). Inspect cord sets before each use.

Controls

Battery Float Charger

Use battery float charger jack to keep the starting battery charged and ready for use. Battery charging should be done in a dry location, such as inside a garage.

1. Plug charger into unit's "Battery Float Charger" jack, which is located next to the start switch. Plug battery charger into a 120 Volt AC wall receptacle.

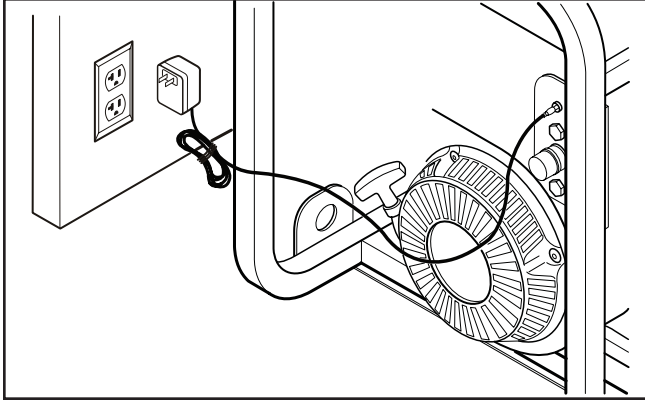

Controls

2. Unplug charger from unit and wall outlet when generator is being started and while it is in operation.
3. Keep this charger plugged in when generator is not in use to prolong battery life. The charger has a built in float equalizer and will not overcharge the battery, even when plugged in for an extended period of time.

IMPORTANT: See *Battery Maintenance* for additional information.

Operation

Starting the Engine

IMPORTANT: Always unplug the battery float charger before starting the generator.

Disconnect all electrical loads from the generator. Use the following start instructions:

1. Make sure unit is on a level surface.

IMPORTANT: Failure to start and operate the unit on a level surface will cause the unit not to start or shut down during operation.

2. Turn the fuel valve to the “On” position. The fuel valve handle should be vertical (pointing toward the ground) for fuel to flow.

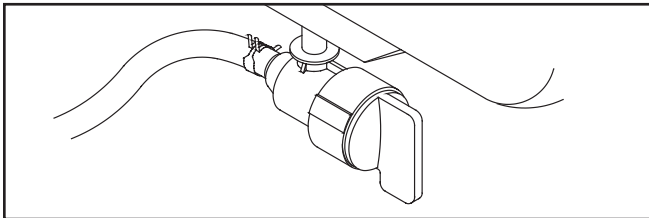

3. Push choke lever to “Choke” position (I\|).

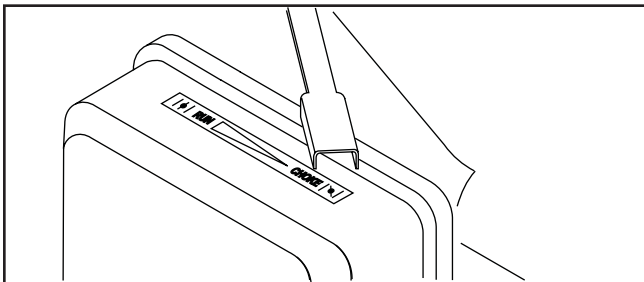

4. Push engine rocker switch to “On”.

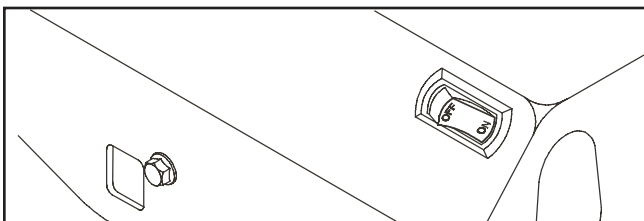

5A. **For electric starting**, push and hold the start button in start position until generator starts. To prolong the life of starter components, **DO NOT** hold start switch in start position for more than 15 seconds, and pause for at least 1 minute between starting attempts.

- If engine starts, proceed to step 7.
- If engine fails to start, proceed to step 6.

NOTE: If battery is discharged, use manual starting instructions.

5B. **For manual starting**, grasp recoil handle and pull slowly until slight resistance is felt. Then pull rapidly one time only to start engine.

- If engine starts, proceed to step 7.
- If engine fails to start, proceed to step 6.

⚠ WARNING	
	<p>Starter cord kickback (rapid retraction) can result in bodily injury. Kickback will pull hand and arm toward engine faster than you can let go.</p> <p>Broken bones, fractures, bruises, or sprains could result.</p>
<ul style="list-style-type: none"> • When starting engine, pull cord slowly until resistance is felt and then pull rapidly to avoid kickback. • NEVER start or stop engine with electrical devices plugged in and turned on. 	



6. Move choke lever to “Half” choke position, and pull recoil handle twice.

- If engine fails to start, repeat steps 5 thru 7.

7. Slowly move choke lever to “Run” position (|↑|). If engine falters, move choke lever to “Half” choke position until engine runs smoothly, and then to “Run” position (|↑|).

IMPORTANT: If engine floods, place choke lever in “Run” position (|↑|) and crank until engine starts.

NOTE: If engine starts after 3 pulls but fails to run, or if unit shuts down during operation, make sure unit is on a level surface and check for proper oil level in crankcase. This unit may be equipped with a low oil protection device. If so, oil must be at proper level for engine to start.

⚠ WARNING	
	<p>Contact with muffler area can result in serious burns.</p>
	<p>Exhaust heat/gases can ignite combustibles, structures or damage fuel tank causing a fire.</p>
<ul style="list-style-type: none"> • DO NOT touch hot parts and AVOID hot exhaust gases. • Allow equipment to cool before touching. • Keep at least 5 feet (1.5 m) of clearance on all sides of generator including overhead. • Code of Federal Regulation (CFR) Title 36 Parks, Forests, and Public Property require equipment powered by an internal combustion engine to have a spark arrester, maintained in effective working order, complying to USDA Forest service standard 5100-1C or later revision. In the State of California a spark arrester is required under section 4442 of the California Public resources code. Other states may have similar laws. 	

Connecting Electrical Loads

1. Let engine stabilize and warm up for a few minutes after starting.
2. Plug in and turn on the desired 120 and/or 240 Volt AC, single phase, 60 Hz electrical loads.

NOTE:

- DO NOT connect 240 Volt loads to the 120 Volt duplex receptacles.
- DO NOT connect 3-phase loads to the generator.
- DO NOT connect 50 Hz loads to the generator.
- DO NOT OVERLOAD THE GENERATOR. See *Don't Overload Generator*.

NOTICE

Exceeding generators wattage/amperage capacity can damage generator and/or electrical devices connected to it.

- DO NOT exceed the generator's wattage/amperage capacity. See *Don't Overload Generator* in the *Operation* section.
- Start generator and let engine stabilize before connecting electrical loads.
- Connect electrical loads in OFF position, then turn ON for operation.
- Turn electrical loads OFF and disconnect from generator before stopping generator.

Stopping the Engine

1. Turn OFF and unplug all electrical loads from generator panel receptacles. NEVER start or stop engine with electrical devices plugged in and turned ON.
2. Let engine run at no-load for several minutes to stabilize internal temperatures of engine and generator.
3. Push engine rocker switch to "Off" position.



WARNING



Backfire, fire or engine damage could occur.

- DO NOT stop engine by moving choke control to "Choke" position (I\I).

4. Move fuel valve to "Off" position.

Don't Overload Generator

Capacity

You must make sure your generator can supply enough rated (running) and surge (starting) watts for the items you will power at the same time. Follow these simple steps:

1. Select the items you will power at the same time.
2. Total the rated (running) watts of these items. This is the amount of power your generator must produce to keep your items running. See Wattage Reference Guide.
3. Estimate how many surge (starting) watts you will need. Surge wattage is the short burst of power needed to start electric motor-driven tools or appliances such as a circular saw or refrigerator. Because not all motors start at the same time, total surge watts can be estimated by adding only the item(s) with the highest additional surge watts to the total rated watts from step 2.

Example:

Tool or Appliance	Rated (Running) Watts	Additional Surge (Starting) Watts
Window Air Conditioner	1200	1800
Refrigerator	800	1600
Deep Freezer	500	500
Television	500	—
Light (75 Watts)	75	—
	3075 Total Running Watts	1800 Highest Surge Watts

Total Rated (Running) Watts = 3075
 Highest Additional Surge Watts = 1800
 Total Generator Output Required = 4875

Power Management

To prolong the life of your generator and attached devices, it is important to take care when adding electrical loads to your generator. There should be nothing connected to the generator outlets before starting its engine. The correct and safe way to manage generator power is to sequentially add loads as follows:

1. With nothing connected to the generator, start the engine as described in this manual.
2. Plug in and turn on the first load, preferably the largest load you have.
3. Permit the generator output to stabilize (engine runs smoothly and attached device operates properly).
4. Plug in and turn on the next load.
5. Again, permit the generator to stabilize.
6. Repeat steps 4 and 5 for each additional load.

NEVER add more loads than the generator capacity. Take special care to consider surge loads in generator capacity, as described above.

Wattage Reference Guide		
Tool or Appliance	Rated* (Running) Watts	Additional Surge (Starting) Watts
Essentials		
Light Bulb - 75 watt	75	—
Deep Freezer	500	500
Sump Pump	800	1200
Refrigerator/Freezer - 18 cf	800	1600
Water Well Pump - 1/3 hp	1000	2000
Heating/Cooling		
Window AC - 10,000 BTU	1200	1800
Window Fan	300	600
Furnace Fan Blower - 1/2 hp	800	1300
Kitchen		
Microwave Oven - 1000 Watt	1000	—
Coffee Maker	1500	—
Electric Stove - Single Element	1500	—
Hot Plate	2500	—
Family Room		
DVD/CD Player	100	—
VCR	100	—
Stereo Receiver	450	—
Color Television - 27 in	500	—
Personal Computer w/17 in monitor	800	—
Other		
Security System	180	—
AM/FM Clock Radio	300	—
Garage Door Opener - 1/2 hp	480	520
Electric Water Heater - 40 gallon	4000	—
DIY/Job Site		
Quartz Halogen Work Light	1000	—
Airless Sprayer - 1/3 hp	600	1200
Reciprocating Saw	960	960
Electric Drill - 1/2 hp	1000	1000
Circular Saw - 7-1/4 in	1500	1500
Miter Saw - 10 in	1800	1800
Table Planer - 6 in	1800	1800
Table Saw/Radial Arm Saw - 10 in	2000	2000
Air Compressor - 1-1/2 hp	2500	2500

* Wattages listed are approximate only. Check tool or appliance for actual wattage.

Maintenance

Maintenance Schedule

Follow the hourly or calendar intervals, whichever occurs first. More frequent service is required when operating in adverse conditions noted below.

Maintenance Schedule - Fill in Dates as You Complete Regular Service								
Maintenance Task	Service Intervals					Service Dates		
	Before Each Use	Every 25 Hours or Yearly	Every 50 Hours or Yearly	Every 100 Hours or Yearly	Every 250 Hours or Yearly			
Clean debris	X							
Check oil level	X							
Change engine oil			X ¹					
Service air cleaner		X ²						
Service spark plug				X				
Service spark arrester				X				
Clean cooling system				X ²				
Check valve clearance					X			
Prepare for storage	If unit is to remain idle for longer than 30 days.							

¹ Change oil after the first (5) operating hours and every 50 hours or every year, whichever occurs first, thereafter. Change oil sooner when operating under dirty or dusty conditions.

² Replace more often under dirty or dusty conditions.

General Recommendations

Regular maintenance will improve the performance and extend the life of the generator. See an authorized dealer for service.

The generator's warranty does not cover items that have been subjected to operator abuse or negligence. To receive full value from the warranty, the operator must maintain the generator as instructed in this manual.

Some adjustments will need to be made periodically to properly maintain your generator.

All service and adjustments should be made at least once each season. Follow the requirements in the Maintenance Schedule chart above.

NOTE: Once a year you should clean or replace the spark plug and replace the air filter. A new spark plug and clean air filter assure proper fuel-air mixture and help your engine run better and last longer.

Emissions Control

Maintenance, replacement, or repair of the emissions control devices and systems may be performed by any non-road engine repair establishment or individual.

However, to obtain "no charge" emissions control service, the work must be performed by a factory authorized dealer. See the *Emissions Warranty*.

Generator Maintenance

Generator maintenance consists of keeping the unit clean and dry. Operate and store the unit in a clean dry environment where it will not be exposed to excessive dust, dirt, moisture, or any corrosive vapors. Cooling air slots in the generator must not become clogged with snow, leaves, or any other foreign material.

NOTE: DO NOT use water or other liquids to clean generator. Liquids can enter engine fuel system, causing poor performance and/or failure to occur. In addition, if liquid enters generator through cooling air slots, some of the liquid will be retained in voids and cracks of the rotor and stator winding insulation. Liquid and dirt buildup on the generator internal windings will eventually decrease the insulation resistance of these windings.

Cleaning

Daily or before use, look around and underneath the generator for signs of oil or fuel leaks. Clean accumulated debris from inside and outside the generator. Keep the linkage, spring and other engine controls clean. Inspect cooling air slots and openings on generator. These openings must be kept clean and unobstructed.

Engine parts should be kept clean to reduce the risk of overheating and ignition of accumulated debris:

- Use a damp cloth to wipe exterior surfaces clean.

NOTICE

Improper treatment of generator can damage it and shorten its life.

- DO NOT expose generator to excessive moisture, dust, dirt, or corrosive vapors.
- DO NOT insert any objects through cooling slots.
- Use a soft bristle brush to loosen caked on dirt or oil.
- Use a vacuum cleaner to pick up loose dirt and debris.

Battery Maintenance

Other than float charging, described elsewhere, no maintenance is required for the starting battery. Keep the battery and terminals clean and dry.

IMPORTANT: Battery charging should be performed in a dry location, such as inside a garage.

Engine Maintenance

WARNING



Unintentional sparking can result in fire or electric shock.

WHEN ADJUSTING OR MAKING REPAIRS TO YOUR GENERATOR

- Disconnect the spark plug wire from the spark plug and place the wire where it cannot contact spark plug.

WHEN TESTING FOR ENGINE SPARK

- Use approved spark plug tester.
- DO NOT check for spark with spark plug removed.

Oil

Oil Recommendations

We recommend the use of Briggs & Stratton Warranty Certified oils for best performance. Other high-quality detergent oils are acceptable if classified for service SF, SG, SH, SJ or higher. DO NOT use special additives.

Outdoor temperatures determine the proper oil viscosity for the engine. Use the chart to select the best viscosity for the outdoor temperature range expected.

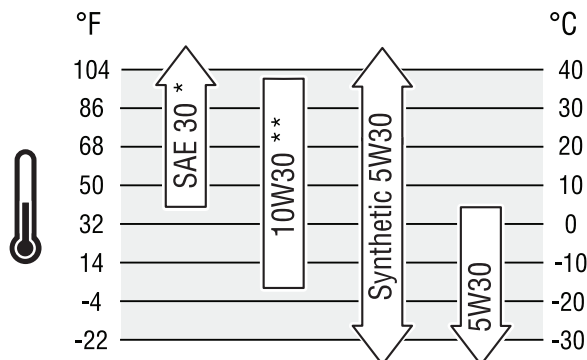

* Below 40°F (4°C) the use of SAE 30 will result in hard starting.

** Above 80°F (27°C) the use of 10W30 may cause increased oil consumption. Check oil level more frequently.



NOTE: Synthetic oil meeting ILSAC GF-2, API certification mark and API service symbol with "SJ/CF ENERGY CONSERVING" or higher, is an acceptable oil at all temperatures. Use of synthetic oil does not alter required oil change intervals.

Checking Oil Level

Oil level should be checked prior to each use or at least every 5 hours of operation. Keep oil level maintained.

1. Make sure generator is on a level surface.
2. Clean area around oil fill and remove oil fill cap.
3. Verify oil is at the point of overflowing at oil fill opening.
4. Replace and tighten oil fill cap.

Adding Engine Oil

1. Make sure generator is on a level surface.
2. Check oil level as described in *Checking Oil Level*.
3. If needed, slowly pour oil into oil fill opening to the point of overflowing at oil fill.
4. Replace and tighten oil fill cap.

Changing Engine Oil

Change the oil after the first 5 hours of operation. Change oil every 50 hours thereafter. If you are using your generator under extremely dirty or dusty conditions, or in extremely hot weather, change the oil more often.

CAUTION

Avoid prolonged or repeated skin contact with used motor oil.

- Used motor oil has been shown to cause skin cancer in certain laboratory animals.
- Thoroughly wash exposed areas with soap and water.



KEEP OUT OF REACH OF CHILDREN. DON'T POLLUTE. CONSERVE RESOURCES. RETURN USED OIL TO COLLECTION CENTERS.

Change the oil while the engine is still warm from running, as follows:

1. Make sure unit is on a level surface.
2. Disconnect the spark plug wire from the spark plug and place the wire where it cannot contact spark plug.

- Clean area around oil drain plug (A). The oil drain plug is located at base of engine, opposite carburetor.

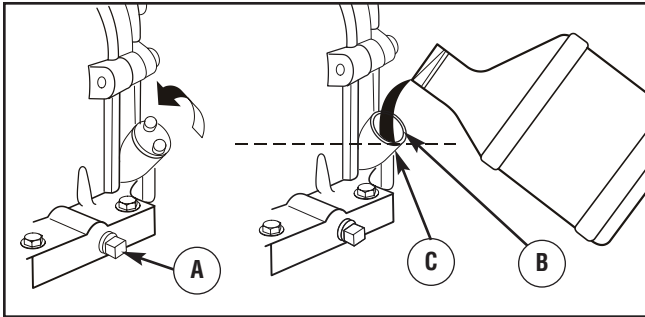

- Remove oil drain plug and drain oil completely into a suitable container.
- Reinstall oil drain plug and tighten securely. Remove oil fill cap.
- Slowly pour oil (about 28 oz.) into oil fill opening (B) to the point of overflowing (C) at oil fill cap. DO NOT overfill.
- Reinstall oil fill cap. Finger tighten cap securely.
- Wipe up any spilled oil.

Service Air Cleaner

Your engine will not run properly and may be damaged if you run it with a dirty air cleaner.

Replace the air cleaner every 25 hours of operation or once each year, whichever comes first. Replace more often if operating under dirty or dusty conditions.

To service the air cleaner, follow these steps:

- Loosen screws (D) and remove air cleaner cover (E).

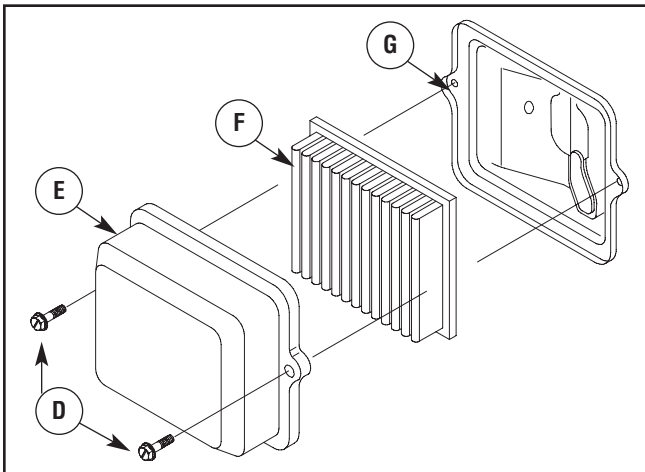

- Carefully remove cartridge (F) from base (G).
- Install clean (or new) air cleaner assembly inside cover. Dispose of old filter properly.
- Assemble air cleaner cover onto base and tighten screws.

Service Spark Plug

Change the spark plug every 100 hours of operation or once each year, whichever comes first. This will help your engine to start easier and run better.

- Clean area around spark plug.
- Remove and inspect spark plug.
- Check electrode gap with wire feeler gauge and reset spark plug gap to recommended gap if necessary (see *Specifications*).

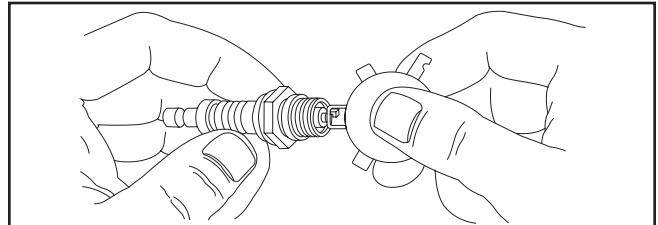

- Replace spark plug if electrodes are pitted, burned or porcelain is cracked. Use the recommended replacement spark plug. See *Specifications*.
- Install spark plug and tighten firmly.

Service Spark Arrester

The engine exhaust muffler has a spark arrester screen. Inspect and clean the screen every 100 hours of operation or once each year, whichever comes first.

If you use your generator on any forest-covered, brush-covered, or grass-covered unimproved land, it must have a spark arrester. The spark arrester must be maintained in good condition by the owner/operator.

⚠ WARNING



Contact with muffler area can result in serious burns.



Exhaust heat/gases can ignite combustibles, structures or damage fuel tank causing a fire.

- DO NOT touch hot parts and AVOID hot exhaust gases.
- Allow equipment to cool before touching.
- Keep at least 5 feet (1.5 m) of clearance on all sides of generator including overhead.
- Code of Federal Regulation (CFR) Title 36 Parks, Forests, and Public Property require equipment powered by an internal combustion engine to have a spark arrester, maintained in effective working order, complying to USDA Forest service standard 5100-1C or later revision. In the State of California a spark arrester is required under section 4442 of the California Public resources code. Other states may have similar laws.

1. To remove muffler heat shield (A) from muffler (B), remove four screws that connect guard to muffler bracket.

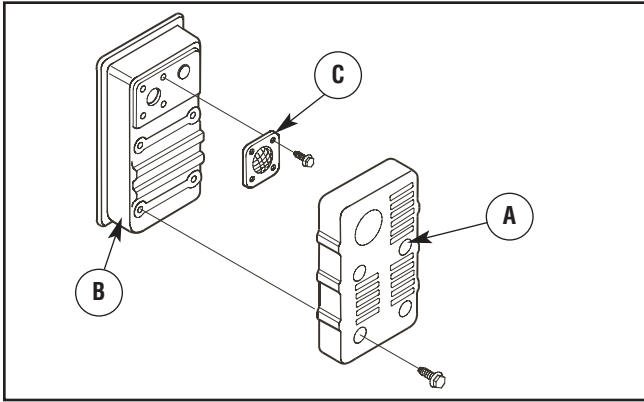

2. Remove four screws that attach spark arrester screen (C).
3. Inspect screen and obtain a replacement if torn, perforated or otherwise damaged. DO NOT use a defective screen. If screen is not damaged, clean it with commercial solvent.
4. Reattach screen and muffler guard.

Air Cooling System

Over time debris may accumulate in cylinder cooling fins and cannot be observed without partial engine disassembly. For this reason, we recommend you have an authorized service dealer clean the cooling system (D) per recommended intervals (see *Maintenance Schedule* in beginning of *Maintenance* section). Equally important is to keep top of engine free from debris. See *Clean Debris*.

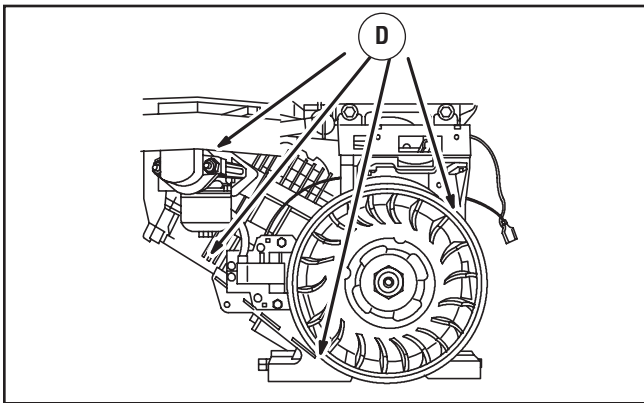

Check Valve Clearance

Regular valve clearance check and adjustment will improve performance and extend engine life. This procedure cannot be done without partial engine disassembly and the use of special tools. For this reason we recommend that you have an authorized service dealer check and adjust valve clearance at recommended intervals (see *Maintenance Schedule* in the *Maintenance* section).

Carburetor Adjustment

The carburetor on this engine is low emission. It is equipped with a non-adjustable idle mixture valve. Top speed has been set at the factory. If adjustment is required, see an authorized service dealer.

CAUTION

Excessively high operating speeds increase risk of injury and damage to generator.

Excessively low speeds impose a heavy load.

- DO NOT tamper with governed speed. Generator supplies correct rated frequency and voltage when running at governed speed.
- DO NOT modify generator in any way.

Storage

The generator should be started at least once every seven days and allowed to run at least 30 minutes. If this cannot be done and you must store the unit for more than 30 days, use the following guidelines to prepare it for storage.

Generator Storage



- Clean the generator as outlined in *Cleaning*.
- Check that cooling air slots and openings on generator are open and unobstructed.

Long Term Storage Instructions

Fuel can become stale when stored over 30 days. Stale fuel causes acid and gum deposits to form in the fuel system or on essential carburetor parts. To keep fuel fresh, use Briggs & Stratton FRESH START™ fuel stabilizer, available as a liquid additive or a drip concentrate cartridge.

There is no need to drain gasoline from the engine if a fuel stabilizer is added according to instructions. Run the engine for 2 minutes to circulate the stabilizer throughout the fuel system. The engine and fuel can then be stored up to 24 months.

If gasoline in the engine has not been treated with a fuel stabilizer, it must be drained into an approved container. Run the engine until it stops from lack of fuel. The use of a fuel stabilizer in the storage container is recommended to maintain freshness.



 WARNING	
	Fuel and its vapors are extremely flammable and explosive.
	Fire or explosion can cause severe burns or death.
WHEN STORING FUEL OR EQUIPMENT WITH FUEL IN TANK	
<ul style="list-style-type: none"> • Store away from furnaces, stoves, water heaters, clothes dryers or other appliances that have pilot light or other ignition source because they can ignite fuel vapors. 	
WHEN DRAINING FUEL	
<ul style="list-style-type: none"> • Turn generator OFF and let it cool at least 2 minutes before removing fuel cap. Loosen cap slowly to relieve pressure in tank. • Drain fuel tank outdoors. • Keep fuel away from sparks, open flames, pilot lights, heat, and other ignition sources. • DO NOT light a cigarette or smoke. 	

Change Engine Oil

While engine is still warm, drain oil from crankcase. Refill with recommended grade. See *Changing Engine Oil*.



Oil Cylinder Bore

- Remove spark plug and pour about 1/2 ounce (15 ml) of clean engine oil into the cylinder.
- Install spark plug and pull starter handle slowly to distribute oil.

 WARNING	
	Unintentional sparking can result in fire or electric shock.
<ul style="list-style-type: none"> • NEVER crank engine with spark plug removed. 	

Other Storage Tips

1. DO NOT store fuel from one season to another unless it has been treated as described in *Long Term Storage Instructions*.
2. Replace fuel container if it starts to rust. Rust and/or dirt in fuel can cause problems if it's used with this unit.
3. Cover unit with a suitable protective cover that does not retain moisture.

 WARNING	
	Storage covers can be flammable.
<ul style="list-style-type: none"> • DO NOT place a storage cover over a hot generator. • Let equipment cool for a sufficient time before placing the cover on the equipment. 	

4. Store generator in clean, dry area.

Troubleshooting

Problem	Cause	Correction
Engine is running, but no AC output is available.	<ol style="list-style-type: none"> 1. One of the circuit breakers is open. 2. Fault in generator. 3. Poor connection or defective cord set. 4. Connected device is bad. 	<ol style="list-style-type: none"> 1. Reset circuit breaker. 2. Contact authorized service facility. 3. Check and repair. 4. Connect another device that is in good condition.
Engine runs good at no-load but “bogs down” when loads are connected.	<ol style="list-style-type: none"> 1. Short circuit in a connected load. 2. Engine speed is too slow. 3. Generator is overloaded. 4. Shorted generator circuit. 	<ol style="list-style-type: none"> 1. Disconnect shorted electrical load. 2. Contact authorized service facility. 3. See <i>Don't Overload Generator</i> in <i>Operation</i> section. 4. Contact authorized service facility.
Engine will not start; or starts and runs rough.	<ol style="list-style-type: none"> 1. Rocker switch set to “Off”. 2. Fuel Valve is in “Off” position. 3. Dirty air cleaner. 4. Out of fuel. 5. Stale fuel. 6. Spark plug wire not connected to spark plug. 7. Bad spark plug. 8. Water in fuel. 9. Flooded. 10. Excessively rich fuel mixture. 11. Intake valve stuck open or closed. 12. Engine has lost compression. 	<ol style="list-style-type: none"> 1. Set switch to “On”. 2. Turn fuel valve to “Open” position. 3. Clean or replace air cleaner. 4. Fill fuel tank. 5. Drain fuel tank and carburetor; fill with fresh fuel. 6. Connect wire to spark plug. 7. Replace spark plug. 8. Drain gas tank and carburetor; fill with fresh fuel. 9. Wait 5 minutes and re-crank engine. 10. Contact authorized service facility. 11. Contact authorized service facility. 12. Contact authorized service facility.
Engine shuts down when running.	Out of fuel.	Fill fuel tank.
Engine lacks power.	<ol style="list-style-type: none"> 1. Load is too high. 2. Dirty air filter. 	<ol style="list-style-type: none"> 1. See <i>Don't Overload Generator</i> in <i>Operation</i> section. 2. Replace air filter.
Engine “hunts” or falters.	Carburetor is running too rich or too lean.	Contact authorized service facility.

Warranties

Emissions Control System Warranty

Briggs & Stratton Corporation (B&S), the California Air Resources Board (CARB) and the United States Environmental Protection Agency (U.S. EPA)

Emissions Control System Warranty Statement (Owner's Defect Warranty Rights and Obligations)

California, United States and Canada Emissions Control Defects Warranty Statement

The California Air Resources Board (CARB), U.S. EPA and B&S are pleased to explain the Emissions Control System Warranty on your small off-road engine (SORE). In California, new small off-road engines model year 2006 and later must be designed, built and equipped to meet the State's stringent anti-smog standards. Elsewhere in the United States, new non-road, spark-ignition engines certified for model year 1997 and later must meet similar standards set forth by the U.S. EPA. B&S must warrant the emissions control system on your engine for the periods of time listed below, provided there has been no abuse, neglect or improper maintenance of your small off-road engine.

Your emissions control system includes parts such as the carburetor, air cleaner, ignition system, fuel line, muffler and catalytic converter. Also included may be connectors and other emissions related assemblies.

Where a warrantable condition exists, B&S will repair your small off-road engine at no cost to you including diagnosis, parts and labor.

Briggs & Stratton Emissions Control Defects Warranty Coverage

Small off-road engines are warranted relative to emissions control parts defects for a period of two years, subject to provisions set forth below. If any covered part on your engine is defective, the part will be repaired or replaced by B&S.

Owner's Warranty Responsibilities

As the small off-road engine owner, you are responsible for the performance of the required maintenance listed in your Operating and Maintenance Instructions. B&S recommends that you retain all your receipts covering maintenance on your small off-road engine, but B&S cannot deny warranty solely for the lack of receipts or for your failure to ensure the performance of all scheduled maintenance.

As the small off-road engine owner, you should however be aware that B&S may deny you warranty coverage if your small off-road engine or a part has failed due to abuse, neglect, improper maintenance or unapproved modifications.

You are responsible for presenting your small off-road engine to an Authorized B&S Service Dealer as soon as a problem exists. The undisputed warranty repairs should be completed in a reasonable amount of time, not to exceed 30 days.

If you have any questions regarding your warranty rights and responsibilities, you should contact a B&S Service Representative at (414) 259-5262.

The emissions warranty is a defects warranty. Defects are judged on normal engine performance. The warranty is not related to an in-use emissions test.

Briggs & Stratton Emissions Control Defects Warranty Provisions

The following are specific provisions relative to your Emissions Control Defects Warranty Coverage. It is in addition to the B&S engine warranty for non-regulated engines found in the Operator's Manual.

1. Warranted Parts

Coverage under this warranty extends only to the parts listed below (the emissions control systems parts) to the extent these parts were present on the engine purchased.

a. Fuel Metering System

- Cold start enrichment system (soft choke)
- Carburetor and internal parts
- Fuel Pump
- Fuel line, fuel line fittings, clamps
- Fuel tank, cap and tether
- Carbon canister

b. Air Induction System

- Air cleaner
- Intake manifold
- Purge and vent line

c. Ignition System

- Spark plug(s)
- Magneto ignition system

d. Catalyst System

- Catalytic converter
- Exhaust manifold
- Air injection system or pulse valve

e. Miscellaneous Items Used in Above Systems

- Vacuum, temperature, position, time sensitive valves and switches
- Connectors and assemblies

2. Length of Coverage

B&S warrants to the initial owner and each subsequent purchaser that the Warranted Parts shall be free from defects in materials and workmanship which caused the failure of the Warranted Parts for a period of two years from the date the engine is delivered to a retail purchaser.

3. No Charge

Repair or replacement of any Warranted Part will be performed at no charge to the owner, including diagnostic labor which leads to the determination that a Warranted Part is defective, if the diagnostic work is performed at an Authorized B&S Service Dealer. For emissions warranty service contact your nearest Authorized B&S Service Dealer as listed in the "Yellow Pages" under "Engines, Gasoline," "Gasoline Engines," "Lawn Mowers," or similar category.

4. Claims and Coverage Exclusions

Warranty claims shall be filed in accordance with the provisions of the B&S Engine Warranty Policy. Warranty coverage shall be excluded for failures of Warranted Parts which are not original B&S parts or because of abuse, neglect or improper maintenance as set forth in the B&S Engine Warranty Policy. B&S is not liable to cover failures of Warranted Parts caused by the use of add-on, non-original, or modified parts.

5. Maintenance

Any Warranted Part which is not scheduled for replacement as required maintenance or which is scheduled only for regular inspection to the effect of "repair or replace as necessary" shall be warranted as to defects for the warranty period. Any Warranted Part which is scheduled for replacement as required maintenance shall be warranted as to defects only for the period of time up to the first scheduled replacement for that part. Any replacement part that is equivalent in performance and durability may be used in the performance of any maintenance or repairs. The owner is responsible for the performance of all required maintenance, as defined in the B&S Operator's Manual.

6. Consequential Coverage

Coverage hereunder shall extend to the failure of any engine components caused by the failure of any Warranted Part still under warranty.

Emission Information

Engines that are certified to meet the California Air Resources Board (CARB) Tier 2 Emission Standards must display information regarding the Emissions Durability Period and Air Index. The engine manufacturer makes this information available to the consumer on emission labels. The engine emission label will indicate certification information.

The **Emissions Durability Period** describes the number of hours of actual running time for which the engine is certified to be emissions compliant, assuming proper maintenance in accordance with the Operating & Maintenance Instructions. The following categories are used:

Moderate: Engine is certified to be emission compliant for 125 hours of actual engine running time.

Intermediate: Engine is certified to be emission compliant for 250 hours of actual engine running time.

Extended: Engine is certified to be emission compliant for 500 hours of actual engine running time.

For example, a typical walk-behind lawn mower is used 20 to 25 hours per year. Therefore, the **Emissions Durability Period** of an engine with an **intermediate** rating would equate to 10 to 12 years.

Certain engines will be certified to meet the United States Environmental Protection Agency (USEPA) Phase 2 emission standards. For phase 2 certified engines, the Emissions Compliance Period referred to on the Emissions Compliance label indicates the number of operating hours for which the engine has been shown to meet Federal emission requirements.

For engines less than 225 cc displacement:

Category C = 125 hours

Category B = 250 hours

Category A = 500 hours.

For engines of 225 cc or more displacement:

Category C = 250 hours

Category B = 500 hours

Category A = 1000 hours.

BRIGGS & STRATTON POWER PRODUCTS GROUP, LLC PORTABLE GENERATOR OWNER WARRANTY POLICY

Effective February 1, 2006 replaces all undated Warranties and all Warranties dated before February 1, 2006

LIMITED WARRANTY

Briggs & Stratton Power Products Group, LLC will repair or replace, free of charge, any part(s) of the portable generator that is defective in material or workmanship or both. Transportation charges on product submitted for repair or replacement under this warranty must be borne by purchaser. This warranty is effective for the time periods and subject to the conditions stated below. For warranty service, find the nearest Authorized Service Dealer in our dealer locator map at BRIGGSandSTRATTON.COM.

THERE IS NO OTHER EXPRESS WARRANTY. IMPLIED WARRANTIES, INCLUDING THOSE OF MERCHANTABILITY AND FITNESS FOR A PARTICULAR PURPOSE, ARE LIMITED TO ONE YEAR FROM PURCHASE, OR TO THE EXTENT PERMITTED BY LAW. ANY AND ALL IMPLIED WARRANTIES ARE EXCLUDED. LIABILITY FOR INCIDENTAL OR CONSEQUENTIAL DAMAGES ARE EXCLUDED TO THE EXTENT EXCLUSION IS PERMITTED BY LAW. Some states or countries do not allow limitations on how long an implied warranty lasts, and some states or countries do not allow the exclusion or limitation of incidental or consequential damages, so the above limitation and exclusion may not apply to you. This warranty gives you specific legal rights and you may also have other rights which vary from state to state or country to country.

WARRANTY PERIOD

Consumer Use	2 years*
Commercial Use	1 year

*Second year parts only

The warranty period begins on the date of purchase by the first retail end user, and continues for the period of time stated above. "Consumer Use" means personal residential household use by a retail consumer. "Commercial Use" means all other uses, including use for commercial, income producing or rental purposes. Once equipment has experienced commercial use, it shall thereafter be considered as commercial use for purposes of this warranty.

NO WARRANTY REGISTRATION IS NECESSARY TO OBTAIN WARRANTY ON BRIGGS & STRATTON PRODUCTS. SAVE YOUR PROOF OF PURCHASE RECEIPT. IF YOU DO NOT PROVIDE PROOF OF THE INITIAL PURCHASE DATE AT THE TIME WARRANTY SERVICE IS REQUESTED, THE MANUFACTURING DATE OF THE PRODUCT WILL BE USED TO DETERMINE THE WARRANTY PERIOD.

ABOUT YOUR WARRANTY

We welcome warranty repair and apologize to you for being inconvenienced. Any Authorized Service Dealer may perform warranty repairs. Most warranty repairs are handled routinely, but sometimes requests for warranty service may not be appropriate. For example, warranty service would not apply if equipment damage occurred because of misuse, lack of routine maintenance, shipping, handling, warehousing or improper installation. Similarly, the warranty is void if the manufacturing date or the serial number on the portable generator has been removed or the equipment has been altered or modified. During the warranty period, the Authorized Service Dealer, at its option, will repair or replace any part that, upon examination, is found to be defective under normal use and service. This warranty will not cover the following repairs and equipment:

- **Normal Wear:** Outdoor Power Equipment, like all mechanical devices, needs periodic parts and service to perform well. This warranty does not cover repair when normal use has exhausted the life of a part or the equipment.
- **Installation and Maintenance:** This warranty does not apply to equipment or parts that have been subjected to improper or unauthorized installation or alteration and modification, misuse, negligence, accident, overloading, overspeeding, improper maintenance, repair or storage so as, in our judgment, to adversely affect its performance and reliability. This warranty also does not cover normal maintenance such as air filters, adjustments, fuel system cleaning and obstruction (due to chemical, dirt, carbon, lime, and so forth).
- **Other Exclusions:** This warranty excludes wear items such as o-rings, filters, etc., or malfunctions resulting from accidents, abuse, modifications, alterations, or improper servicing or freezing or chemical deterioration. Accessory parts such as starting batteries, generator adapter cord sets and storage covers are excluded from the product warranty. This warranty excludes used, reconditioned, and demonstration equipment, equipment used for prime power in place of utility power, equipment used in life support applications, and failures due to acts of God and other force majeure events beyond the manufacturers control. 198189E, Rev. B, 12/31/2006

BRIGGS & STRATTON POWER PRODUCTS GROUP, LLC
JEFFERSON, WI, USA



Portable Generator

Product Specifications

Starting Wattage	8,750 watts
Wattage	6,200 watts
AC Load Current:	
at 120 Volts	.51.6 Amps
at 240 Volts	.25.8 Amps
Phase	Single phase
Rated Frequency	.60 Hertz
Shipping Weight	.190 lb (86.2 kg)
Displacement	.20.85 ci (342 cc)
Spark Plug Gap	.0.030 in (0.76 mm)
Fuel Capacity	.7 U.S. gallons (26.5 L)
Oil Capacity	.28 Ounces (0.83 Liters)

Common Service Parts

Air Cleaner	.491588S or 5043D
Resistor Spark Plug	.491055S
Long Life Platinum Spark Plug	.5066D
Engine Oil Bottle	.100005
Fuel Stabilizer	.5041D
Spark Arrester	.83083GS

Power Ratings: The gross power rating for individual gas engine models is labeled in accordance with SAE (Society of Automotive Engineers) code J1940 (Small Engine Power & Torque Rating Procedure), and rating performance has been obtained and corrected in accordance with SAE J1995 (Revision 2002-05). Torque values are derived at 3060 RPM; horsepower values are derived at 3600 RPM. Actual gross engine power will be lower and is affected by, among other things, ambient operating conditions and engine-to-engine variability. Given both the wide array of products on which engines are placed and the variety of environmental issues applicable to operating the equipment, the gas engine will not develop the rated gross power when used in a given piece of power equipment (actual "on-site" or net power). This difference is due to a variety of factors including, but not limited to, accessories (air cleaner, exhaust, charging, cooling, carburetor, fuel pump, etc.), application limitations, ambient operating conditions (temperature, humidity, altitude), and engine-to-engine variability. Due to manufacturing and capacity limitations, Briggs & Stratton may substitute an engine of higher rated power for this Series engine.