

M a n u a l



U s e r ' s

VL2000™ Spot Luminaire

02.9673.0001

VARI*TMLITE®
Express yourself.

VARI*LITE - VL2000™ SPOT LUMINAIRE USER'S MANUAL

VARI*LITE®, Artisan®, VL2®, and VLD® are trademarks owned by Vari-Lite, Inc., 201 Regal Row, Dallas TX 75247 USA. and are registered in the United States and other countries.

VL1000™, VL2000™, VL2201™, VL2202™, VL2400™ (and the individual product designations), VL3000™, Virtuoso™, Virtuoso™ DX, VARI*LITE Visionary™, VLI™, VL2B™, VL2C™, VL3™, VL4™, VL5™, VL5Arc™, VL5B™, VL6™, VL6B™, VL6C™, VL7™, VL7B™, VLM™, APS6™, C3™, ArtisanVLQ™, SPC-36™, UDM™, AutoTruss™, SmartDMX™, Smart Repeater™, Series 100™, Series 200™, Series 300™, Series 2000™, Series 3000™, DICHRO*WHEEL™, DICHRO*TUNE™, VACU*DEF™, VARI*IMAGE™, VARI*BEAM™, and the Vari-Lite Asterisk are also trademarks owned by Vari-Lite, Inc.

VARI*LITE® products are protected by one or more of the following patents, and other pending patent applications worldwide:
US Patents No. 5,959,758; 5,728,994; 5,590,954; 5,367,444; 5,329,431; 5,209,560; 5,186,536; 5,073,847; 5,010,459; 4,980,806; 4,602,321; 4,392,187; U.S. Design Patents No. 366,712; 359,574;

Australia Patents No. 703868; 693691; 683695; 667109; 657152; 649264; 646588; 618559; 586095; 576400; 575271; 546433; Australia Design Reg. No. 126781;

German Patents No. (DBP) 69314122.0; 69208615.3; 69207692.1; 69121029.2; 3768727.1; 3750201.8; 3587270.5; 3279888.1; 3274291.6; DGM G9312884; DGM 9407689.8;

European Patents No. 0586049 (FR, GB); 0547732 (BE, DK, FR, GB); 0534710 (BE, FR, GB); 0474202 (BE, DK, FR, GB); 0253082 (BE, FR, GB); 0253081 (BE, FR, GB); 0192882 (BE, FR, GB); 0140994 (BE, FR, GB); 0060068 (BE, FR, GB);

France Design Reg. No. 335132 - 335147;

Spain Patents No. 2090191; 2084289; 2082384; 2058071; 2020960; 0548328; Spain Utility Model No. 2031748; Spain Design Reg. No. 129596;

Japan Patents No. 2,059,669; 2,055,324; 2,002,168; 1,889,481; 1,770,241; 1,723,825; 1,683,007; 1,553,011; KR 206051; 181180; 76310; 47673; Japan Design Reg. No. 947552; 945436-1; 945436;

Korean Design Reg. No. 175178;

Mexico Patents No. 180148; 179138;

Taiwan Patents No. 78726; 66975; 65380; 63471; 40611; 28275;

United Kingdom Design Reg. No. 2042174; 2033108; 2029499.

Apple®, Macintosh®, and FireWire® are registered trademarks of Apple Computer, Inc.

All other brand or product names which may be mentioned in this manual are trademarks or registered trademarks of their respective companies or organizations.

VL2000™ Spot Luminaire User's Manual

The information furnished in this manual is for informational use only and is subject to change without notice. Vari-Lite, Inc. assumes no responsibility or liability for any errors or inaccuracies that may appear in this manual. All information and graphic representations are property of Vari-Lite, Inc. 201 Regal Row, Dallas, Texas 75247 USA.

Version as of: 17-Sep-02

Printed in the USA.

Part number: 02.9673.0001 C

VL2000™ Spot Luminaire User's Manual
© 2000-2002 Vari-Lite, Inc. All Rights Reserved.

How To Obtain Warranty Service

A copy of the Vari-Lite, Inc. Limited Warranty was included in the shipping package for this VARI*LITE® product.

To obtain warranty service, please contact customer service at 1-877-VARI-LITE (1-877-827-4548) or customerservice@vlint.com and request a Return Material Authorization (RMA) for warranty service. You need to provide the model and serial number of the item being returned, a description of the problem or failure and the name of the registered user or organization. If available, you should have your sales invoice to establish the date of sale as the beginning of the warranty period. The form at the end of this manual should be completed and included with the product when shipping.

Once you obtain the RMA, pack the product in its original packing material along with a copy of your invoice (if available), the completed service form, and write the RMA number legibly on or near the shipping address label. Return the unit, freight prepaid to:

Vari-Lite, Inc.
201 Regal Row
Dallas, TX 75247
Attention: Warranty Service

As stated in the warranty, it is required that the shipment be insured and FOB our service center.

Compliance Notice

FCC This equipment has been tested and found to comply with the limits for a Class A digital device pursuant to Part 15 of FCC Rules. These limits are designed to provide reasonable protection against harmful interference when this equipment is operated in a commercial environment. This equipment generates, uses, and can radiate radio frequency energy and, if not installed and used in accordance with Vari-Lite system, service, and safety guidelines, may cause harmful interference to radio communications. Operation of this equipment in a residential area is likely to cause harmful interference, in which case the user will be required to correct the interference at his/her own expense.

CE Declaration of Conformity

We declare, under our sole responsibility, that this product complies with the relevant clauses of the following standards and harmonized documents:

Safety

EN 60598-1:1997 Luminaire Safety Standard, General Requirements

EN 60598-2 17:1989 Specification for Luminaires for Stage and Studio Lighting

EMC

EN 55022A:1994 Radiated and Conducted Emissions

EN 50082-1:1997 Generic Immunity Standard

We certify that the product conforms to the protection requirements of council directives: 73/23/EEC (LVD) and 89/336/EEC (EMC)

Safety Notice

It is extremely important to read ALL safety information and instructions provided in this manual and any accompanying documentation before installing and operating the products described herein. Heed all cautions and warnings during installation and use of this product.

Safety symbols used throughout this manual are as follows:



CAUTION advising of potential damage to product.



WARNING advising of potential injury or death to persons.

GENERAL INFORMATION PERTAINING TO PROTECTION AGAINST ELECTRICAL SHOCK, FIRE, EXPOSURE TO EXCESSIVE UV RADIATION, AND INJURY TO PERSONS CAN BE FOUND BELOW.

WARNING:

INSTRUCTIONS FOR CONTINUED PROTECTION AGAINST FIRE

1. VARI*LITE® luminaires have been designed for use only with certain Philips and Osram HID lamps. Note lamp type (MSR400, MSR575HR etc.) before replacing lamps. Installing another type of lamp may be hazardous.
2. Luminaires may be mounted on any type of surface as long as mounting instructions are followed. See instructions detailed in this manual.
3. Replace fuses with same type and rating only.
4. Note distance requirement from combustible materials or illuminated objects for VARI*LITE® luminaires.

WARNING:

INSTRUCTIONS FOR CONTINUED PROTECTION AGAINST ELECTRICAL SHOCK

1. VARI*LITE® luminaires are designed for dry locations only. Exposure to rain or moisture may damage luminaire.
2. Disconnect power before servicing any VARI*LITE® equipment.
3. Servicing to be performed by qualified personnel only.

WARNING:

INSTRUCTIONS FOR CONTINUED PROTECTION AGAINST EXCESSIVE EXPOSURE TO UV RADIATION

1. Many VARI*LITE® luminaires use an HID type lamp that produces UV radiation. DO NOT look directly at lamp.
2. It is hazardous to operate luminaires without lens or shield. Shields, lenses, or ultraviolet screens shall be changed if they have become visibly damaged to such an extent that their effectiveness is impaired. For example, by cracks or deep scratches.

WARNING:

INSTRUCTIONS FOR PROTECTION AGAINST INJURY TO PERSONS

1. Exterior surfaces of the luminaire will be hot during operation. Use appropriate safety equipment (gloves, eye protection, etc.) when handling and adjusting hot equipment and components.
2. Luminaires will have a hot lamp when operating. Disconnect power and allow lamp to cool before replacing.
3. Arc lamps emit ultraviolet radiation which can cause serious skin burn and eye inflammation. Additionally, arc lamps operate under high pressure at very high temperatures. Should the lamp break, there can exist a danger of personal injury and/or fire from broken lamp particles being discharged.
4. Wear eye protection when relamping.
5. Appropriate safety equipment (gloves, eye protection) should be used when handling damaged lamps.
6. If lamp is touched with bare hands, clean lamp with denatured alcohol and wipe with lint-free cloth before installing or powering up the luminaire.
7. The lamp shall be changed if it has become damaged or thermally deformed.

WARNING:

RF INTERFERENCE

1. This is a Class A product. In a domestic environment this product may cause radio interference, in which case, the user may be required to take adequate measures.

ARC LAMP CHARACTERISTIC CONSIDERATIONS

1. Arc lamps require a period of time to relight after a power interruption or a severe voltage dip. In some cases, lamp will automatically relight after it has cooled depending on Lamp Power-Up State (L ON/ LOFF) system configuration setting.
2. Burning position is Universal.

Sicherheitshinweise

Es ist äußerst wichtig, ALLE Sicherheitsinformationen und -hinweise in diesem Handbuch und dem beiliegenden Informationsmaterial zu lesen, bevor Sie die hierin beschriebenen Produkte installieren bzw. bedienen. Halten Sie bei der Installation und dem Einsatz dieses Produkts alle Warnhinweise und Vorsichtsmaßnahmen ein.

Folgende Sicherheitssymbole werden in diesem Handbuch verwendet:



VORSICHT - weist auf möglichen Produktschaden hin.



WARNUNG - weist auf mögliche Körperverletzung und Lebensbedrohung hin.

NACHSTEHEND FINDEN SIE ALLGEMEINE HINWEISE ÜBER SICHERHEITSVORKEHRUNGEN GEGEN ELEKTROSCHOCK, FEUER, ÜBERHÖHTE UV-STRAHLUNG UND KÖRPERVERLETZUNGEN.

WARNUNG:

HINWEISE ZUM FEUERSCHUTZ

1. VARI*LITE®-Scheinwerfer sind ausschließlich für den Einsatz mit bestimmten Philips und Osram HID-Lampen geeignet. Achten Sie auf den Lampentyp (MSR400, MSR575HR etc.), bevor Sie die jeweiligen Lampen ersetzen. Die Installation eines anderen Lampentyps kann gefährlich sein.
2. Scheinwerfer können auf jeder beliebigen Oberfläche montiert werden, solange Sie die Montageanweisungen befolgen. Detaillierte Hinweise finden Sie in diesem Handbuch.
3. Ersetzen Sie Sicherungen nur mit Sicherungen vom gleichen Typ und gleicher Stärke.
4. Beachten Sie die Einhaltung des erforderlichen Sicherheitsabstandes der VARI*LITE®-Scheinwerfer von brennbarem Material oder beleuchteten Objekten.

WARNUNG:

HINWEISE ZUM SCHUTZ GEGEN ELEKTROSCHOCK

1. VARI*LITE®-Scheinwerfer eignen sich ausschließlich für trockene Standorte. Regen oder Feuchtigkeit können die Scheinwerfer beschädigen.
2. Unterbrechen Sie die Stromzufuhr, bevor Sie mit der Arbeit an VARI*LITE®-Geräten beginnen.
3. Die Geräte sollten nur von qualifiziertem Personal gewartet werden.

WARNUNG:

HINWEISE ZUM SCHUTZ GEGEN ÜBERHÖHTE UV-STRAHLUNG

1. Viele VARI*LITE®-Scheinwerfer verwenden einen HID-Lampentyp, der UV-Strahlen abgibt. **SCHAUEN SIE NICHT** direkt in die Lampe.
2. Es ist gefährlich, Leuchten ohne Linsen oder Blenden zu bedienen. Blenden, Linsen oder Ultraviolettsschirme müssen ausgetauscht werden, sofern deren Schutzwirkung durch sichtbare Beschädigung (z. B. Sprünge oder Schrammen) eingeschränkt ist.

WARNUNG:

HINWEISE ZUM SCHUTZ GEGEN KÖRPERVERLETZUNGEN

1. Bei Betrieb sind die Außenflächen der Scheinwerfer heiß. Verwenden Sie bei der Bedienung von aufgeheizter Apparatur die jeweils geeignete Sicherheitsausrüstung (Handschuhe, Augenschutz etc.).
2. Bei Betrieb der Scheinwerfer ist die Lampe heiß. Unterbrechen Sie die Stromzufuhr und lassen Sie die Lampe abkühlen, wenn Sie diese austauschen.
3. Bogenlampen senden ultraviolette Strahlen aus, die Hautverbrennungen und Augenzündungen verursachen können. Der Betrieb von Bogenlampen erfolgt unter Hochdruck und bei hohen Temperaturen. Sollte die Lampe zerbrechen, besteht die Gefahr von Körperverletzung bzw. von Feuer, das von Lampenteilen ausgelöst werden kann.
4. Tragen Sie beim Austausch der Lampen einen Augenschutz.
5. Die geeignete Sicherheitsausrüstung (Handschuhe, Augenschutz) sollte beim Umgang mit beschädigten Lampen verwendet werden.
6. Wenn die Lampe mit bloßen Händen berührt wird, reinigen Sie sie mit denaturiertem Alkohol und einem flusenfreien Tuch, bevor Sie die Scheinwerfer installieren oder in Betrieb nehmen.
7. Wenn die Lampe beschädigt oder durch Hitzeeinwirkung deformiert ist, muß diese ausgetauscht werden.

WARNUNG:

HF-INTERFERENZ

1. Es handelt sich um ein Produkt der Klasse A. In einer Wohnumgebung kann das Produkt Hochfrequenzstörungen verursachen. In diesem Fall müssen eventuell geeignete Maßnahmen getroffen werden.

BESONDERHEITEN VON BOGENLAMPEN

1. Bogenlampen benötigen eine gewisse Zeitdauer, um nach einem Stromausfall oder einem Spannungsgefälle wieder aufzuleuchten. In einigen Fällen wird die Lampe nach Abkühlung automatisch wieder aufleuchten, je nach der Systemkonfigurationseinstellung des Lampeneinschaltungsstatus (L ON/ LOFF).
2. Die Brennposition ist Universal.

Notes de sécurité

Avant de procéder à l'installation des produits décrits dans ce guide et de les mettre en marche, il est extrêmement important de lire TOUS les renseignements et TOUTES les directives de sécurité contenues dans ce guide ainsi que toute documentation jointe. Tenir compte de tous les avertissements et suivre toutes les précautions pendant l'installation et l'utilisation de cet appareil.

Les symboles de sécurité utilisés dans ce guide sont les suivants :



ATTENTION Ce symbole annonce que l'appareil risque d'être endommagé.



AVERTISSEMENT Ce symbole annonce qu'il y a risque d'accident grave ou même fatal.

CETTE SECTION CONTIENT DES INFORMATIONS GÉNÉRALES POUR SE PROTÉGER CONTRE LES DÉCHARGES ÉLECTRIQUES, LES INCENDIES, L'EXPOSITION EXCESSIVE AUX RAYONS UV ET TOUT AUTRE ACCIDENT POUVANT ENTRAÎNER DES BLESSURES.

AVERTISSEMENT:

DIRECTIVES POUR SE PROTÉGER CONTRE LES INCENDIES

1. Les luminaires VARI*LITE® ont été conçus pour être utilisés uniquement avec certaines lampes Philips et Osram HID. Vérifier le type de lampe (MSR400, MSR575HR etc.) avant de remplacer les lampes. L'installation d'un autre type de lampe peut poser un danger.
2. Les luminaires peuvent être fixés sur tout type de surface tant que les directives de montage sont respectées. Voir les explications détaillées dans ce guide.
3. Ne remplacer les fusibles qu'avec ceux du même type, ayant les mêmes caractéristiques.
4. Vérifier la distance à respecter entre les matériaux combustibles ou les objets illuminés et les luminaires VARI*LITE®.

AVERTISSEMENT:

DIRECTIVES POUR SE PROTÉGER CONTRE LES DÉCHARGES ÉLECTRIQUES

1. Les luminaires VARI*LITE® sont conçus pour une utilisation au sec uniquement. Une exposition à la pluie et à l'humidité risque d'endommager le luminaire.
2. Débrancher l'appareil avant de procéder à la révision de tout matériel VARI*LITE®.
3. Les révisions doivent être effectuées uniquement par des personnes qualifiées.

**AVERTISSEMENT:
DIRECTIVES POUR SE PROTÉGER CONTRE UNE EXPOSITION EXCESSIVE
AUX RAYONS UV**

1. Plusieurs luminaires VARI*LITE® utilisent une lampe de type HID qui produit des rayons UV. NE PAS fixer son regard sur la lampe.
2. L'utilisation des luminaires sans lentille ou blindage pose des risques. Tous blindages, lentilles ou écrans ultraviolet visiblement endommagés au point que leur efficacité en est affectée doivent être remplacés, par exemple s'il y a des fissures ou de profondes rayures.

**AVERTISSEMENT:
DIRECTIVES POUR SE PROTÉGER CONTRE LES ACCIDENTS POUVANT
ENTRAÎNER DES BLESSURES**

1. Les surfaces externes du luminaire deviennent brûlantes quand l'appareil est en marche. Pour manœuvrer ou ajuster des appareils brûlants et leurs composants, se protéger suffisamment (gants, protection pour les yeux, etc.).
2. La lampe du luminaire est brûlante lorsqu'il est en marche. Débrancher le courant et attendre que la lampe ait refroidi avant de la remplacer.
3. Les lampes à arc émettent des rayons ultraviolets pouvant causer de graves brûlures sur la peau et une inflammation des yeux. De plus, les lampes à arc fonctionnent sous haute tension à de très hautes températures. Si la lampe se casse, les particules de la lampe cassée peuvent causer blessures et/ou incendie en s'éparpillant.
4. Se protéger les yeux pour remplacer la lampe.
5. Utiliser des appareils de protection appropriés (gants, protection des yeux) pour manier des lampes endommagées.
6. Si la lampe a été touchée avec des mains nues, la nettoyer avec de l'alcool dénaturé et l'essuyer avec un chiffon non-pelucheux avant d'installer ou de brancher le luminaire.
7. Si la lampe a été endommagée ou a reçu une déformation thermique, elle doit être remplacée.

**AVERTISSEMENT:
INTERFÉRENCE RF**

1. Cet appareil est de Classe A. Dans un environnement domestique, cet appareil peut causer des interférences radio, et si c'est le cas, l'utilisateur peut avoir à prendre des mesures adéquates.

CONSIDÉRATIONS DES CARACTÉRISTIQUES DE LAMPES À ARC

1. Après une interruption de courant ou une baisse importante de voltage, les lampes à arc mettent du temps avant de se rallumer. Dans certains cas, la lampe se rallumera automatiquement après s'être refroidie. Cela dépend de la manière dont le système est réglé pour le statut de mise en marche de la lampe (L ON/ LOFF).
2. La position Brûler est Universelle.

Aviso sobre Seguridad

Es muy importante leer TODA la información e instrucciones sobre seguridad que se indica en este manual así como en los documentos adjuntos antes de instalar y operar los productos descritos. Se debe prestar atención a todos los avisos y advertencias durante la instalación y uso de este producto.

Los símbolos de seguridad usados en este manual son los siguientes:



CUIDADO, indica posibles daños al producto.



ADVERTENCIA, indica posibles lesiones o muerte a las personas.

LA INFORMACIÓN GENERAL RELACIONADA A LA PROTECCIÓN CONTRA GOLPES DE CORRIENTE ELÉCTRICA, INCENDIO, EXPOSICIÓN EXCESIVA A RADIACIÓN ULTRA VIOLETA Y LESIONES A LAS PERSONAS SE PUEDE ENCONTRAR SEGUIDAMENTE:

ADVERTENCIA:

INSTRUCCIONES PARA PROTECCIÓN CONTINUA CONTRA INCENDIO

1. Las luminarias VARI*LITE® han sido diseñadas para ser usadas solamente con algunas lámparas HID Philips y Osram. Tome nota del tipo de lámpara (MSR400, MSR575HR etc.) antes de reemplazarla. Instalación de otro tipo de lámpara puede ser peligroso.
2. Las luminarias se pueden instalar en cualquier tipo de superficie siempre que se sigan las instrucciones de instalación. Vea las instrucciones detalladas en este manual.
3. Reemplace los fusibles solamente con los del mismo tipo y especificación.
4. Tome nota de los requerimientos de distancia de materiales combustibles u objetos iluminados para las luminarias VARI*LITE®.

ADVERTENCIA:

INSTRUCCIONES PARA PROTECCIÓN CONTINUA CONTRA CHOQUE ELÉCTRICO

1. Las luminarias VARI*LITE® están diseñadas solamente para lugares secos. La exposición a la lluvia o humedad pueden dañar la luminaria.
2. Desconecte la energía antes de dar servicio a cualquier equipo de VARI*LITE®.
3. El servicio debe ser realizado solamente por personal calificado.

ADVERTENCIA:

INSTRUCCIONES PARA PROTECCIÓN CONTINUA CONTRA LA EXPOSICIÓN EXCESIVA DE RADIACIÓN ULTRA VIOLETA

1. Muchas luminarias VARI*LITE® usan un tipo de lámpara HID que produce radiación UV. NO mire directamente a la lámpara.
2. Es peligroso operar luminarias sin lentes o protectores. Debe cambiar los protectores, lentes o pantallas ultravioletas si se aprecia que han sido dañadas, y que su efectividad pudiera estar deteriorada. Por ejemplo, si tuvieran rajaduras o raspaduras profundas.

ADVERTENCIA:

INSTRUCCIONES PARA PROTECCIÓN CONTRA LESIONES DE PERSONAS

1. Las superficies exteriores de las luminarias están calientes durante su operación. Use un equipo de seguridad apropiado (guantes, protección para los ojos, etc.) cuando haga ajustes en el equipo y componentes que están calientes.
2. Cuando las luminarias están en operación la lámpara estará muy caliente. Desconecte la energía y deje que la lámpara se enfríe antes de reemplazarla.
3. Las lámparas de arco emiten radiaciones ultravioletas que pueden ocasionar serias quemaduras a la piel e inflamación a los ojos. Además, las lámparas de arco operan a alta presión y muy alta temperatura. Si la lámpara se rompe, puede existir el peligro de lesiones al personal o un incendio ocasionado por las partículas de la lámpara rota que se caen.
4. Use protección para los ojos cuando vuelve a colocar una lámpara nueva.
5. Use un equipo de seguridad apropiado (guantes, protección para los ojos, etc.) cuando trabaje con lámparas dañadas.
6. Si toca la lámpara con las manos, limpie la lámpara con alcohol desnaturalizado y con tela sin pelusas antes de instalar o volver a conectar la luminaria.
7. Cambie la lámpara si está dañada o deformada termicamente.

ADVERTENCIA:

INTERFERENCIA RF

1. Este es un producto de Clase A. En el ambiente de la casa este producto puede ocasionar radiointerferencia, en cuyo caso, el usuario debe tomar las medidas adecuadas.

CONSIDERACIONES SOBRE LAS CARACTERÍSTICAS DE LA LÁMPARA DE ARCO

1. Las lámparas de arco requieren un período de tiempo para volver a iluminarse después de una interrupción de energía o de una severa caída de voltaje. En algunos casos, la lámpara se volverá a iluminar en forma automática después que se ha enfriado dependiendo de la configuración del sistema de energía de la lámpara (L ON / L OFF) (L encendida / L apagada).
2. La posición de encendido es universal.

安全性に関する注意事項

ここに記載されている製品を取り扱う場合は、まず本マニュアルおよび付属のマニュアルの安全性に関する情報と説明をすべてお読みください。また、実際に本製品を取り付けたり使用する際には、すべての注意事項および警告に留意して作業してください。

本マニュアルでは、以下の安全マークを使用しています。



注意：製品に損傷を与える危険性があります。



警告：人身事故につながる危険性があります。

感電、火災、UV放射に対する過度の露出、および人身事故を防ぐための一般的な情報については、以下の説明をお読みください。

警告：

火災の発生を防ぐためのヒント

1. VARI*LITE® 照明器具は、Philips および Osram の HID ランプを使用するように設計されています。ランプを交換する際は、ランプの種類（MSR400、MSR575HR など）を確認するようにしてください。他の種類のランプを取り付けると危険です。
2. 照明器具は、本マニュアルの指示に従って操作するかぎり、どのようなタイプの表面にでも取り付けることができます。詳細については、本マニュアルを参照してください。
3. ヒューズを交換する場合は、同じヒューズ（同じ種類、同じクラス）を使用してください。
4. VARI*LITE® 照明器具は、可燃性物質または他の光源から必要な距離だけ離して配置してください。

警告：

感電を防ぐためのヒント

1. VARI*LITE® 照明器具は、乾燥した環境で使用するように設計されています。雨で濡れる場所や湿気の多い場所に取り付けると、照明器具が傷むことがあります。
2. VARI*LITE® 照明器具を修理点検する場合は、必ず先に電源を切ってください。
3. 照明器具の修理点検は、資格を持つ技師のみが行うようにしてください。

警告：

過度の UV 放射にさらされないためのヒント

1. VARI*LITE® 照明器具の多くは、UV 放射を生ずる HID タイプのランプを使用しています。ランプを直視することは避けてください。
2. レンズまたはシールドを使わずに照明器具を点灯すると危険です。レンズ、シールド、紫外線画面は、ひび割れや深い引っかき傷などにより、その効力が損なわれるようになったら取り替えるようにします。

警告：

人身事故を防ぐためのヒント

1. 照明器具が点灯しているときは、その外側が熱くなります。熱くなった器具やコンポーネントを取り扱う際には、適切な防具（手袋や保護用眼鏡）を使用してください。
2. 照明器具が点灯しているときは、そのランプが熱くなります。ランプを交換する場合は、照明器具の電源を切り、ランプの温度が下がるまで待ってください。ランプの裏ぶたをあけると、遮断スイッチが働いて、ランプの電源が切れる場合があります。
3. アーク灯は紫外線を放射します。この紫外線によって、ひどい火傷を負ったり、目の炎症を起こすことがあります。さらに、アーク灯は、高圧高温の状態で光を放射します。そのため、万一アーク灯が破損すると、飛び散った破片で人身事故や火災が発生する危険性があります。
4. 再点灯するときには、保護用眼鏡を着用してください。
5. 損傷したランプを取り扱う場合は、適切な防具（手袋や保護用眼鏡）を着用してください。
6. 手袋を着用せずに直接手でランプを触った場合は、変性アルコールを使ってランプをきれいにし、糸くずの出ない布で拭いてから照明器具を取り付け、電源を入れるようにします。
7. 傷がついたランプや熱によって変形したランプは取り替えてください。

警告：

RF 干渉

1. 本製品は Class A に分類されます。本製品は、家庭環境において無線干渉を起こす可能性があります。その場合、使用者は適切な処置を取らなければならないことがあります。

アーク灯の特性

1. 停電後または大きな電圧ディップ後にアーク灯を再点灯する場合は、しばらく時間をおくようにしてください。Lamp Power-Up State (L ON/L OFF) システム設定によっては、温度が下がったときに自動的に再点灯される場合があります。
2. アーク灯は点光源です。

Table of Contents

Introduction

About This Manual	1
Additional Documentation.....	1
Text Conventions	2
Customer Service	2

Chapter 1. Description

Features

Overview	4
Standard Features	4

Components

VL2000 Spot Luminaire	5
Menu Display	6
LED Indicators	6

Accessories

Replacement Items/Accessories.....	7
------------------------------------	---

Chapter 2. Installation

Power and Data Cabling Requirements

Power	10
Current vs. Voltage.....	11
Data Cables	12
Recommended Cable Types/Manufacturers	13
Male Termination Connector	14
Loopback Connector	14

Installation Procedures

Installing Lamp	15
Hanging the Luminaire	16
Floor Mounting the Luminaire.....	19
Connecting Data and Power.....	19

Powering Up

Power-Up Procedure	20
Align Lamp for Flat Field	21
Set DMX Mode	22

Addressing

Program Starting Address	23
Program Starting Address Without Calibrating the Luminaire	23

Chapter 3. Operation

Color/Gobo Control	
Color/Gobo Wheel Positions	26
Standard Colors and Gobos	26
Standard Colors - Wheel 1 (Color Wheel).....	26
Standard Gobos - Wheel 2 (Fixed Gobo Wheel)	27
Standard Rotating Gobos	27
DMX Modes	
8-Bit and 16-Bit Modes	28
DMX Mapping	
Color/Gobo Wheels	29
Rotating Gobo Index/Rotation	33
Rotating Gobo Wheel	33
Beam Control.....	34
Beam Iris	34
Edge	34
Strobe	34
Zoom	34
Luminaire Timing	
Luminaire Timing Channel Information	35
Control Channel Functions.....	43
Updating Software	
Reprogramming Luminaires.....	44
Install and Reprogramming Procedure	45
Transferring Software From Luminaire to Luminaire.....	48
Hardware Requirements.....	48
Transfer Procedure	48

Chapter 4. Menu System

Operation	
What Is the Menu System?.....	52
Controls Operation	52
Display Orientation.....	53
Default State.....	54
Decimal Placement	54
Display Test	55
Shortcuts	55
Error Messages.....	56
Mapping	
Menu System Overview	57
Menu System Functions	58
Function Definitions.....	62

Cues and Sequences

- Overview 66
- Storing 66
- Playback 66
- Hardware Requirements 66
- Cue Operations..... 67

Self Tests

- Running Parameter Tests 71
- Move Disable 71
- Lamp..... 72
- Diagnostic Tests 73
- Test Descriptions 73

Appendix A. Troubleshooting and Maintenance

Troubleshooting

- Protecting Your Warranty 84
- Troubleshooting Guide 85

Routine Maintenance

- Lamp Replacement 91
- Color Filter Replacement 93
- Fixed Gobo Replacement..... 95
- Rotating Gobo Replacement 97
- Cleaning Optical Lenses and Filters 99

Appendix B. Technical Specifications

- Mechanical 101
- Optical..... 102
- Operational..... 102
- Photometric 103

Notes

Introduction

About This Manual

This manual provides necessary information regarding product safety, installation, operation, and routine maintenance for the VARI*LITE® VL2000™ Spot Luminaire. Familiarizing yourself with this information will help you to get the most out of your luminaire.



WARNING: It is important to read ALL accompanying safety and installation instructions to avoid damage to the product and potential injury to yourself or others.

Additional Documentation

A service manual is available for extended maintenance of the VL2000 Spot Luminaire. This manual is available in both printed and electronic (PDF) formats.

- VL2000 Spot Luminaire Service Manual (02.9673.0010).
- Troubleshooting, Component Replacement, Illustrated Parts Breakdown.

Note: Performing maintenance procedures contained in the VL2000 Spot Luminaire Service Manual may void the product warranty. Refer to the Vari-Lite, Inc. Limited Warranty card included in the shipping package for this VARI*LITE® product.

For more information on DMX512 systems, refer to the following document available from United States Institute for Theatre Technology, Inc. (USITT).

- Digital Data Transmission Standard for Dimmers & Controllers plus AMX 192 Analog Multiplex Data Transmission Standard for Dimmers & Controllers. (A copy of Recommended Practice for DMX512 is included.)
USITT Inc.
Suite 5A, 10 West 19th St.
New York, NY 10011-4206 USA
Tel : (212) 924 - 9088 Fax : (212) 924 - 9343
www.usitt.org

Text Conventions

The following styles and meanings are used throughout this manual:

[Button]	Front panel button. Example: Press [Menu].
[Up] / [Down] arrows	Press either [Up] or [Down] arrow button at Menu Display.
MENU	Menu Display read-out. Example: Press [Up] / [Down] arrows until CFG (Configuration) appears.

Customer Service

Our Goal

At Vari-Lite, we are committed to providing you the highest quality in customer service. Our comprehensive resources are available to help your business succeed and ensure you get the full benefit of being a Vari-Lite customer. Whether your needs are telephone/troubleshooting assistance, product training or technical service, our full-time staff of experienced professionals are on-hand to provide support.

How to Reach Us

For assistance in your area, call the dealer from which your product(s) were purchased.

or

Contact an Authorized Service Center.

or

Contact the Vari-Lite Customer Service Department, 9am - 6pm CST Monday through Friday, at the following:

phone: 1-877-VARI-LITE (1-877-827-4548)

fax: 214.630.5867

email: customerservice@vari-lite.com

Additional Resources

For additional resources and documentation, please visit our website at: www.vari-lite.com and follow the Support link.



CHAPTER 1.

Description

This chapter contains descriptions of luminaire features and components, along with a list of accessories which are available.

- **Features**
- **Components**
- **Accessories**

Features

Overview

Standard Features

The VL2000 spot luminaire contains the following standard features:

- Variable beam focus to soften the edges of gobos or spots and enable gobo morphing.
- Full field dimmer to allow smooth timed fades and fast blackouts.
- A mechanical iris which provides continuous beam size control for both rapid beam size changes and smooth timed beam angle changes.
- Rotatable gobo wheel which contains five individually rotatable, indexable gobos.
- Two, 12-position wheels, each providing 11 easily loaded positions (and 1 open) for interchangeable dichroic color and gobo selections.
- Zoom optics system with a zoom angle of 2.8 to one.
- Power factor corrected arc power supply for a Philips arc lamp.
- 700 watt arc source.
- Faceted reflector designed for an optimal flat field.
- Control by DMX512 protocol.
- Two truss hook brackets for versatile hanging configurations.

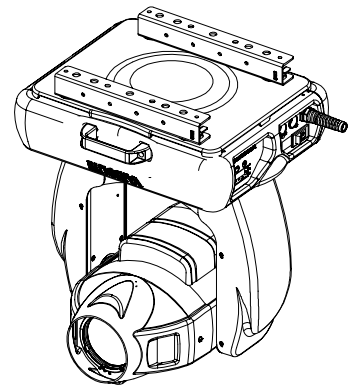

Components

VL2000 Spot Luminaire

The following illustration shows the major luminaire components and controls.

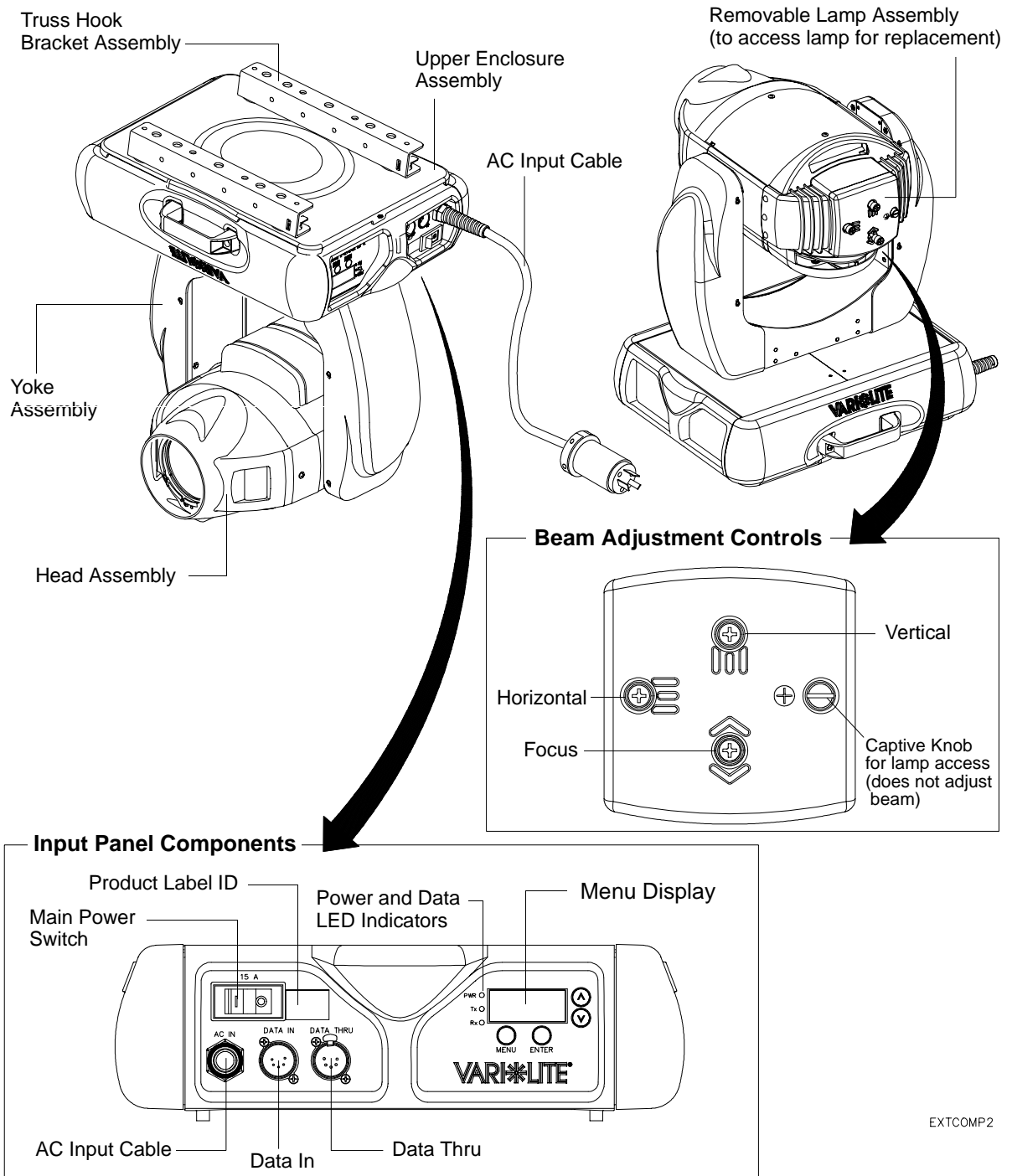

EXTCOMP2

Menu Display

The Menu System Display is used to access the menu system, which is a programmable set of commands used to address, operate, and test the luminaire.

The menu system is controlled by four buttons. These buttons function as follows:

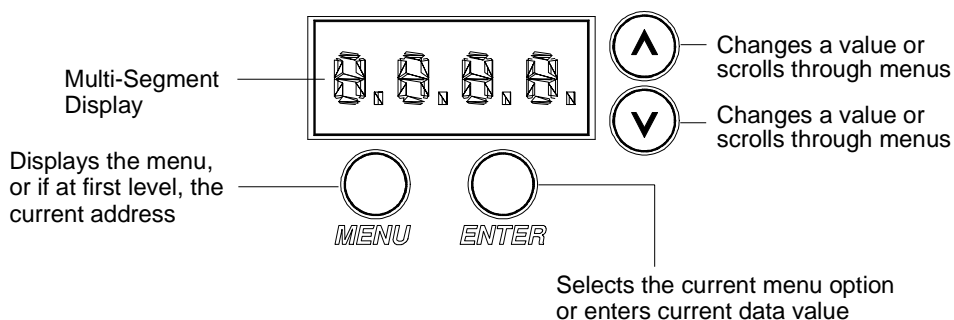

Refer to [“Menu System” chapter on page 51](#) for more detailed instructions regarding display orientation and operation.

LED Indicators

The LED indicators report the status of power and data to the luminaire.

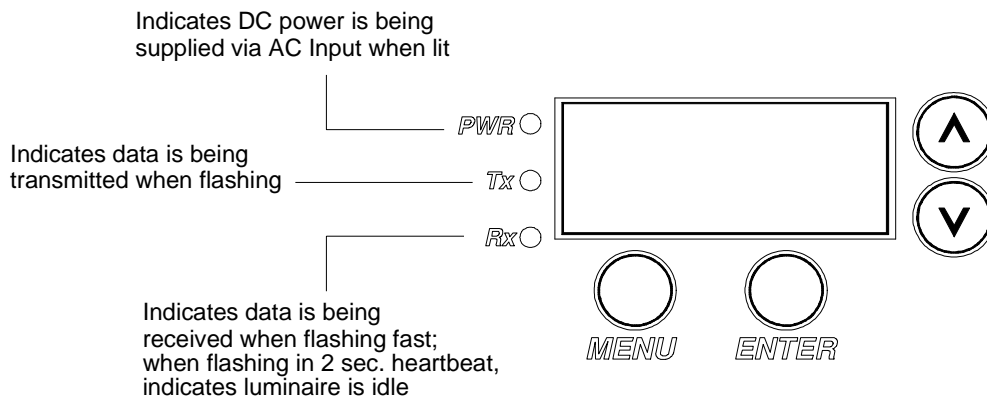

Accessories

Replacement Items/Accessories

The following optional and/or replacement items can be ordered directly from Vari-Lite. (Please order by Vari-Lite part number.)

Vari-Lite Part No.	Accessory
20.9625.0132	Plastic Road Case (Two Hole)
22.9620.0194	Safety Cable Assembly
23.9623.0177	DMX Termination Male Connector Assembly
25.9661.0056	Loopback Connector Assembly
25.9661.0057	DMX Termination Female Connector Assembly
28.9661.054	Luminaire Programming (XLR5) Kit
55.6841.0001	Mega Claw Truss Hook, 2" Round
55.6840.0001	Mega Clamp Truss Hook, Round and Square
71.2528.0700	700 Watt Short-Arc Lamp

Notes



CHAPTER 2.

Installation

This chapter contains instructions for installation of the luminaire. It includes connecting power and data, along with instructions for powering up the luminaire for the first time and addressing it within your system.

- **Power and Data Cabling Requirements**
- **Installation Procedures**
- **Powering Up**
- **Addressing**

Power and Data Cabling Requirements

Power

The luminaire requires standard AC power distribution from 100-240 VAC, 50/60 Hz. Three amps to twelve amps will be required depending on the AC supply voltage and product model.

Depending on the application, the luminaire's AC input cable may require a different connector. If required, install a new connector meeting your requirements using the following wire color code reference:

Wire*	Connection
Green/Yellow	AC Ground
Blue	AC Neutral
Brown	AC Line

* International (Harmonized) Standard



WARNING: DO NOT connect to three-phase service in countries with 240 volt power.

For single-phase power at 100 to 240 volts RMS:

Connection	Pin
AC Neutral	X
AC Line	Y
Ground (Earth)	G

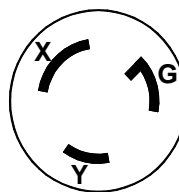

For three-phase power at 208 volts RMS:

Connection	Pin
Phase 1	X
Phase 2	Y
Ground (Earth)	G

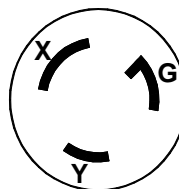

Current vs. Voltage

The following table provides the luminaire’s current draw at specific voltages. Current is calculated with the lamp on and all motors sequencing.

Table 2-1: Current vs. Voltage

Voltage @ 60Hz	Current
90.0	11.8
100.0	10.6
110.0	9.5
120.0	8.5
130.0	7.9
140.0	7.2
180.0	5.5
190.0	5.2
200.0	4.9
210.0	4.7
220.0	4.5
230.0	4.3
240.0	4.1
250.0	3.9

Data Cables

The luminaire is equipped with two, 5-pin XLR connectors for DATA IN and DATA THRU (out) applications. DATA IN requires a 5-pin, female XLR connector and DATA THRU requires a 5-pin, male XLR connector. When purchasing or constructing data cables, it is important that not only the correct cable type be used, but also quality cable to ensure a reliable DMX512 system. Your cabling should meet the following USITT DMX specification requirements:

- Suitable for use with EIA485 (RS485) operation at 250k baud.
- Characteristic impedance 85-150 ohms, nominally 120 ohms.
- Low capacitance.
- Two twisted pairs.
- Foil and braid shielded.
- 24 AWG min. gauge for runs up to 1000 feet (300m).
- 22 AWG min. gauge for runs up to 1640 feet (500m).

Note: Microphone type cables and other general purpose, two-core audio or signal cables are not suitable for use with DMX512.

Refer to the USITT Recommended Practice for DMX512 guide for additional information regarding DMX512 systems. How to obtain a copy is detailed in [“Additional Documentation” on page 1.](#)

The XLR 5-pin connectors should be wired as follows:

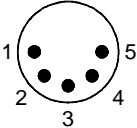
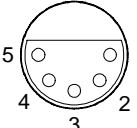
Pin/Wire Code to XLR Connectors						
Data Thru Cable Pinout	Pin 1	Pin 2	Pin 3	Pin 4	Pin 5	Data In Cable Pinout
 Male Conn	Foil & Braided Shield	1st conductor of 1st twisted pair	2nd conductor of 1st twisted pair	1st conductor of 2nd twisted pair	2nd conductor of 2nd twisted pair	 Female Conn
		Data (-)	Data (+)	Data (-)	Data (+)	

Recommended Cable Types/Manufacturers

These are only a few of the suitable cable types. Any quality EIA485, twisted pair, 120 ohm, shielded cable will also work.

Type	Pairs	ZΩ*	Jacket	AWG	Use	Temp (F)
Belden Cables						
1215A	2	150	PVC	26	IBM Type 6 Office cable	75
1269A	2	100	PTFE	22 (Solid)	High Temp, Plenum cable	200
8102	2	100	PVC	24	UL2919	80
8132	2	120	PVC	28	UL2919	80
8162	2	100	PVC	24	UL2493	60
82729	2	100	PTFE	24	High Temp, Plenum cable	200
88102	2	100	PTFE	24	High Temp, Plenum cable	200
89696	2	100	PTFE	22	High Temp, Plenum cable	200
89729	2	100	PTFE	24	High Temp, Plenum cable	200
89855	2	100	PTFE	22	High Temp, Plenum cable	200
9729	2	100	PVC	24	UL2493	60
9804	2	100	PVC	28	UL2960	60
9829	2	100	PVC	24	UL2919	80
9842	2	120	PVC	24	UL2919	80
Proplex Cables						
PC224P	2	110	Polyurethane	22	Heavy Duty and Portable	105
PC224T	2	110	PVC	22	UL2464	105
PC226T	3	110	PVC	22	UL2464	

* Characteristic Impedance

Male Termination Connector

A male XLR termination connector is required at the last luminaire (or "far end of the line") to prevent signal reflections. Signal reflections may cancel out the signal at certain line lengths, resulting in errors. The terminator is also necessary for software downloads and running tests on multiple luminaires. To construct your own connector, you will need the following components:

- 5-pin, male XLR connector.
- Two 1/4W 5% 120 ohm resistors.

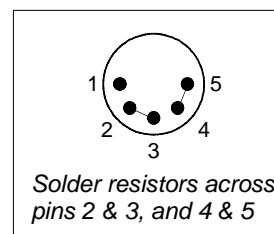

Note: A male termination connector is available as an accessory from Vari-Lite. See [“Accessories” on page 7.](#)

Loopback Connector

When transferring software versions from luminaire to luminaire, a loopback connector is required at the first luminaire in the data link.

To construct your own connector, you will need the following components:

- 5-pin, female XLR connector.
- Two small segments of 22AWG wire.

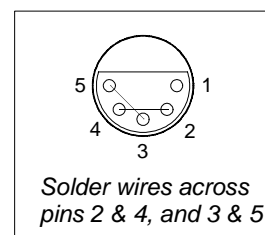

Note: A loopback connector is available as an accessory from Vari-Lite. See [“Accessories” on page 7.](#)

Installation Procedures

Installing Lamp

In the event the lamp was packed separately during shipment, it will be necessary to install in the luminaire before use.



WARNING: Ensure that power is removed from luminaire when installing lamp.



CAUTION: Wear cotton gloves or other covering while installing lamp. Touching lamp glass with bare fingers will leave oil and may cause the lamp to explode or reduce lamp life. If touched, use alcohol and cotton cloth to thoroughly clean glass portion of lamp.

To install lamp:

- Step 1. Ensure power is removed from luminaire.
- Step 2. Remove lamp from shipping box.
- Step 3. At backcap, using slotted screwdriver (or fingers) turn captive knob until loose.
- Step 4. Slide backcap away from head assembly (it will remain attached by tether and lamp wires.).

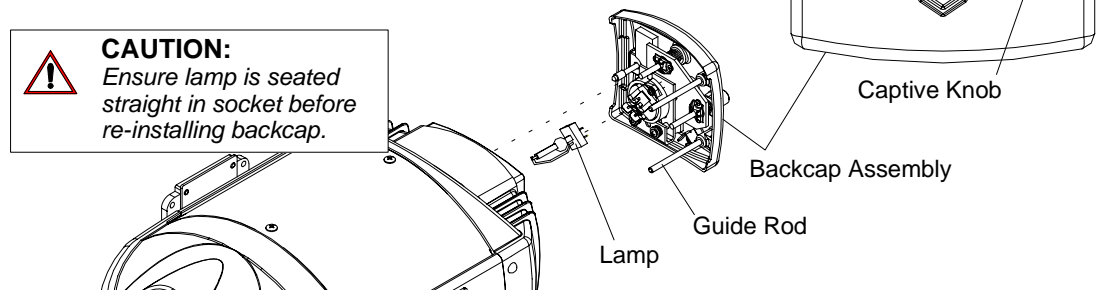

- Step 5. Install lamp by pressing into socket. Ensure lamp is fully seated in socket and parallel to guide rods. (Lamp can be damaged when inserted through reflector if not parallel to guide rods.)
- Step 6. Align guide rods in guide holes and slide backcap into head assembly. Retighten captive knob.

Note: After installing a new lamp, it is necessary to adjust the beam for optimum performance. This procedure is covered in [“Powering Up” on page 20](#).

Hanging the Luminaire

The luminaire can be hung horizontally or vertically from any structure designed to work with the type of load created by this moving luminaire. Two truss hook bracket assemblies (provided) are used to attach truss hooks or other mounting hardware as required. Many compatible truss hooks are available from different manufacturers for your particular needs.

A minimum of one hook per truss hook bracket is required. If mounting method does not use truss hooks, two attachment points per truss hook bracket are required. When attaching more than one point on a single bracket, the attach points must be spaced as far apart as possible using the supplied mounting holes.

A safety cable is recommended for all hanging installations and may be required by local codes.

Install mounting hardware and brackets:

Step 1. Install truss hooks on two provided truss hook brackets as required.

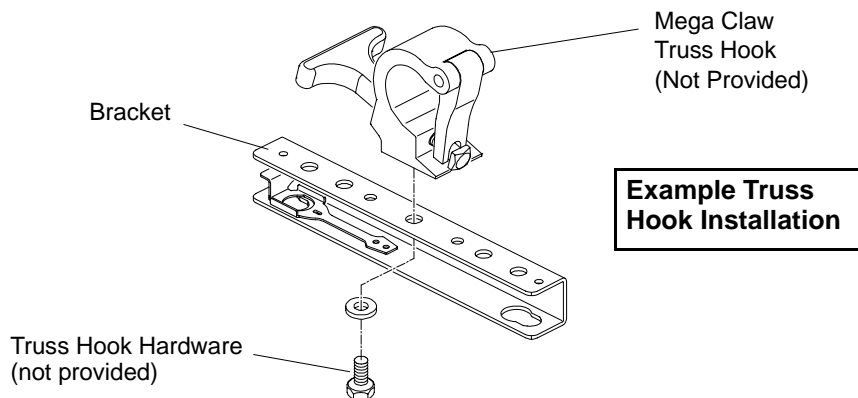

Note: Various types of truss hooks can be used. The Mega Claw truss hook (as shown in the example above) as well as many other standard hooks, can be ordered separately.

Step 2. Determine required configuration of bracket installation. Brackets may be installed in either orientation as shown.

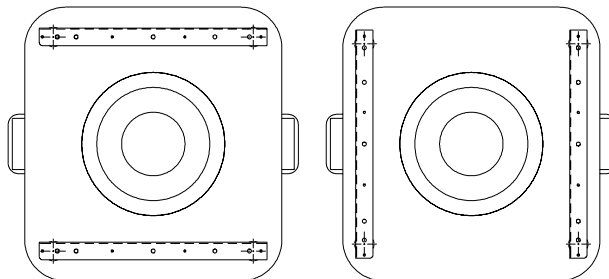

Step 3. While pulling up on locking mechanism release, fit keyed holes onto raised mounting buttons at bottom of enclosure. Slide forward and release locking mechanism to lock in place. Ensure brackets are locked securely. (Always face brackets in same direction as shown.)



WARNING: Ensure that the bracket locking mechanism is fully seated after the bracket is installed on the luminaire.

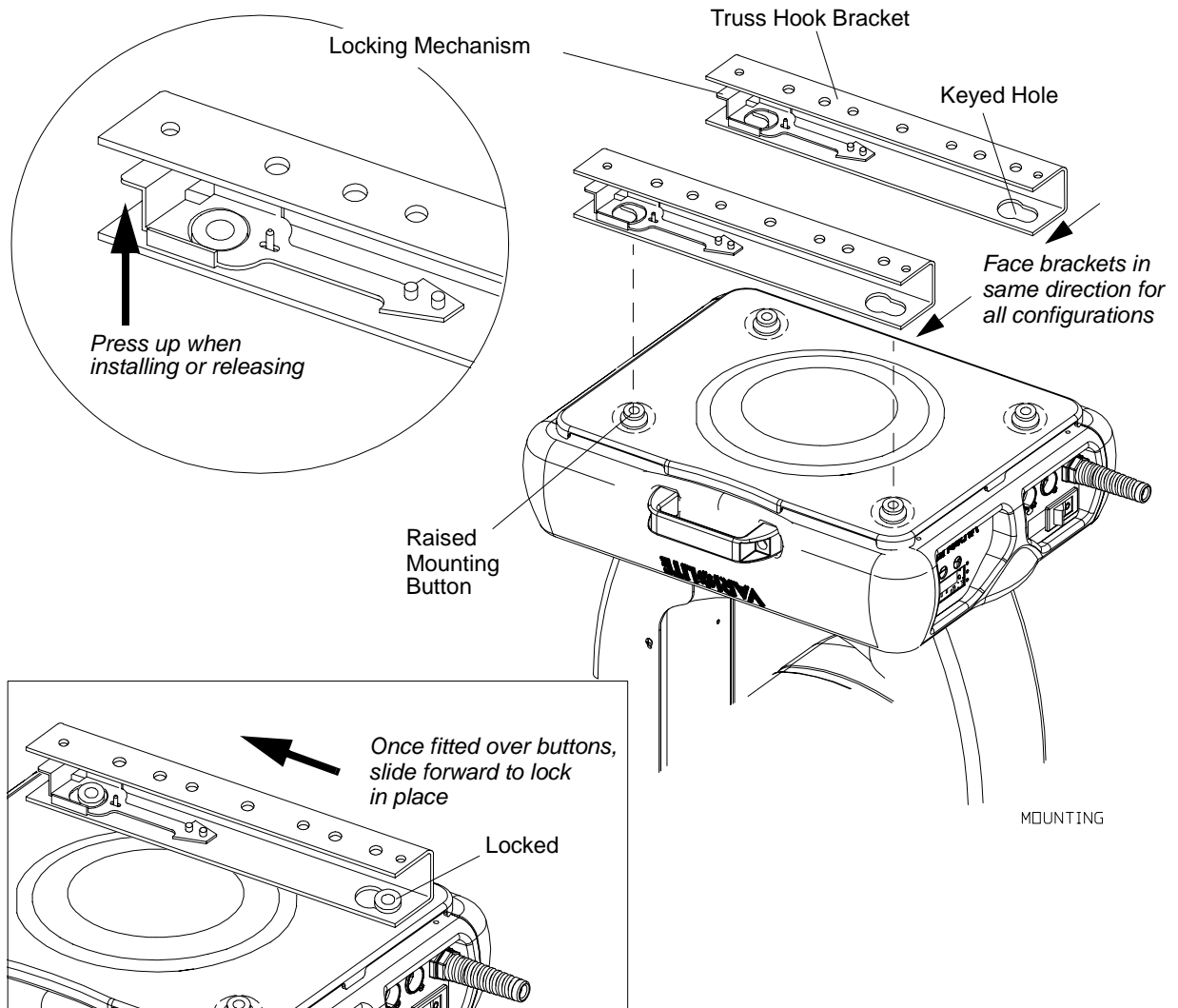

Installing in Truss:

- Step 1. Using two people, lift luminaire into mounting position.
- Step 2. Secure in place with truss hook. Ensure truss hook hardware that locks hook in place (e.g. wing bolt) is properly tightened and that luminaire is fully supported.
- Step 3. Attach safety cable (as required) as follows :
 - a. Connect one end of cable to luminaire handle.
 - b. Loop at least once around truss/pipe and attach other end of cable to other handle.
- Step 4. Connect power and data cables according to procedure given in [“Connecting Data and Power”](#) on page 19.

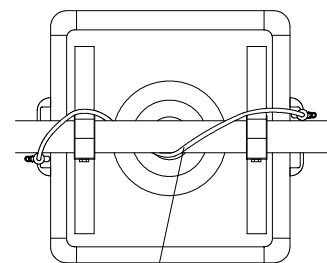

Safety Cable Loop at least once.

Safety Cable:
 Recommended for hanging installations.
 May be required by local codes.

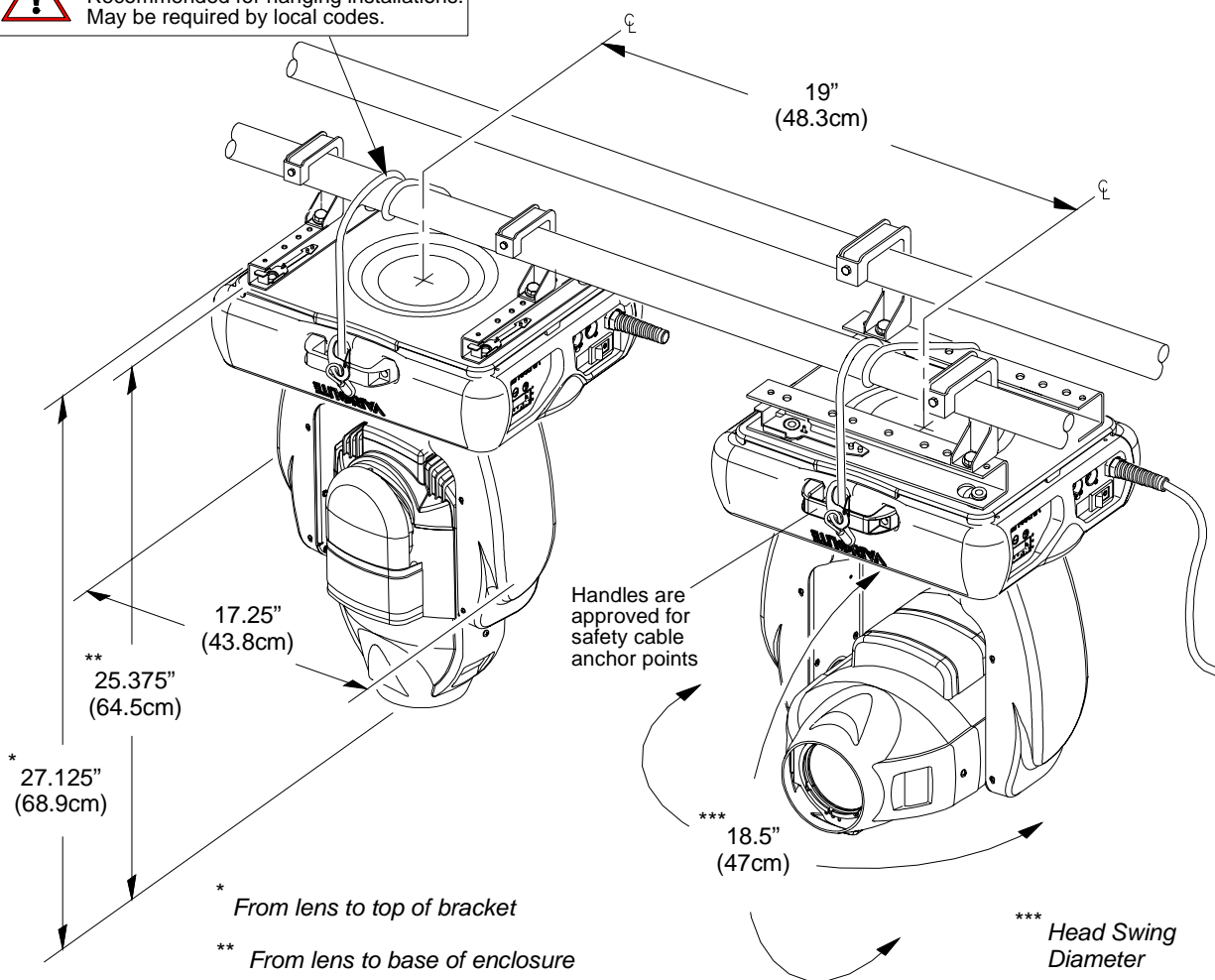

Floor Mounting the Luminaire

The luminaire enclosure is sufficient to stabilize the luminaire in a floor installation, provided that the mounting surface is flat and sturdy.

Connecting Data and Power

A maximum of 32 luminaires may be connected in any one DMX data link.

Note: This maximum limit applies to the luminaire "daisy chain" only. Your system or console may require fewer luminaires on a single data link path. Consult your console documentation for more information.

To connect power and data:

- Step 1. Connect data cable from console to first luminaire in chain at DATA IN connector.
- Step 2. If required, connect additional data cables from DATA THRU connectors to DATA IN connectors of remaining luminaires in link.
- Step 3. At last luminaire in link, install male termination connector at DATA THRU connector. (Luminaires and other devices on the same DMX chain may not function properly without termination.)

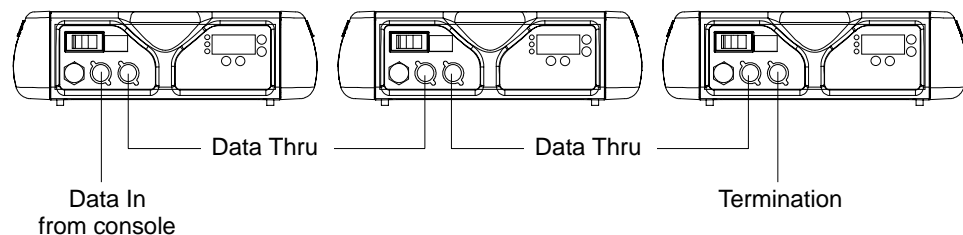

- Step 4. Connect AC Input Cable connector to power input source.
- Step 5. Dress AC input and data cables and secure them so that they will not interfere with luminaire head and yoke movement.

Powering Up

Power-Up Procedure

Since Lamp On is the default state, the lamp will strike when the luminaire is powered up for the first time. When AC power is applied, the luminaire will immediately begin a calibration sequence that steps it through full pan and tilt movements. The internal color, gobo, and beam mechanisms will also move through a full range of motion. After calibration, the luminaire head will either stop at its "home" position (which positions the pan axis at mid-rotation and the head parallel to the yoke with the lens pointing away from the luminaire upper enclosure) or move to its current DMX-defined position if DMX data is present. All internal mechanisms also move to their "home" or DMX-defined positions.

Subsequently, depending on the luminaire's setting for Lamp Power-Up State (refer to ["Menu System Functions" on page 58](#)), when power is applied, the arc lamp will either **a)** "strike" or ignite - Lamp On (*default*), **b)** await calibration and then strike - Cal On, or **c)** await manual command to strike - Lamp Off.



CAUTION: Before applying power, be sure the luminaire is hung or positioned so that the head and yoke can move freely without restriction.

To power up:

- Step 1. At each luminaire, apply power by switching power switch to "I" (ON) position. Luminaire will automatically step through following procedure:
 - a. If Lamp Power-Up State is set to Lamp On, lamp will strike (ignite).
 - b. Luminaire will cycle through calibration and stop at "home" position.
 - c. If Lamp Power-Up State is set to Cal On, lamp will strike (ignite) at end of calibration sequence.

Align Lamp for Flat Field

The design of the VL2000 spot luminaire optical system is based on a flat field. A flat field is one where there is no detectable hot spot.

After a new lamp is installed, it will be necessary to align the lamp to optimize the beam for the flat field. Knobs located at the luminaire's backcap will allow adjustment.



WARNING: Backcap and adjustment knobs will be HOT during lamp operation. Wear gloves and/or use tools to prevent burns.

To align lamp:

- Step 1. Using internal menus select **Lamp** test to set beam. See "[Lamp](#)" on page 72 for more information. (If using console, set intensity to 100%, open beam size iris and focus for hard edge.)
- Step 2. Position beam on a white wall at a distance of 10' to 20'.
- Step 3. At backcap, using Vertical and Horizontal knobs, adjust hot spot to center of beam.
- Step 4. Using Focus knob, adjust beam for best spot.

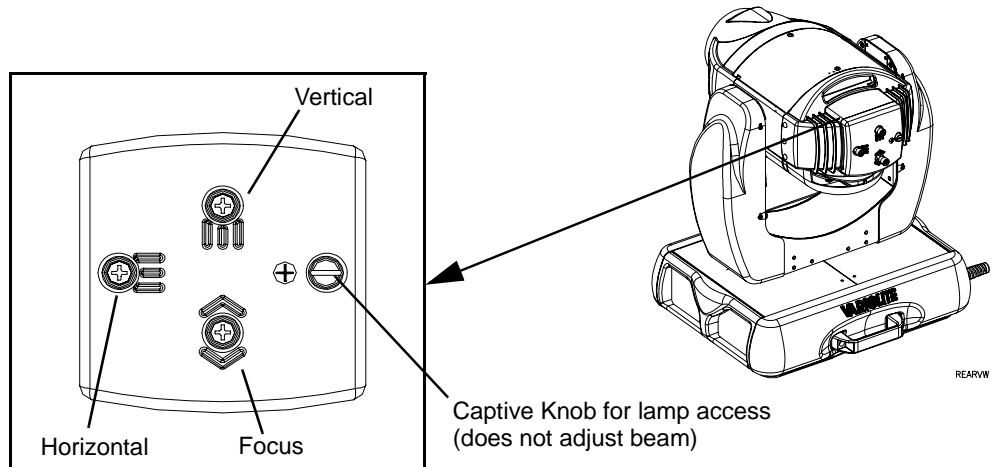

Set DMX Mode

The VL2000 Series luminaires provide four modes for DMX operation. The mode is set using the luminaire's Menu Display.

- **8-bit Standard** - provides one 8-bit DMX channel for control of each luminaire function.
- **8-bit Enhanced** - provides additional channels for timing control.
- **16-bit Standard** - provides 16-bit control for pan/tilt.
- **16-bit Enhanced (default)** - provides 16-bit control for pan/tilt and additional channels for timing control.

To set the mode:

Step 1. Press [Menu].

Step 2. Press [Up] or [Down] button until **DMX** appears. Press [Enter].

Step 3. Press [Up] or [Down] to until desired mode is reached (**8**, **16**, **E 8**, or **E 16**). Press [Enter] to set mode.

See [“DMX Modes” on page 28](#) for more information.

Note: Which mode is used may also be determined by the profile available in the DMX control console. For best control, response, smoothest movement and transitions, the 16-bit Enhanced mode is recommended. The 8-bit modes are supported for older style consoles with a limited number of DMX channels available, and if profiles are not supported. The 16-bit mode is supported for DMX consoles that do not provide access to the timing channels through either their architecture or their profiles. For more information see [“Luminaire Timing Channel Information” on page 35](#).

Addressing

Program Starting Address

The address setting for DMX console or Virtuoso console controlled systems is entered using the Menu Display. (Refer to “[Menu System](#)” chapter on page 51 for detailed instructions.)

The luminaire retains the DMX and Virtuoso addresses that are stored even if power is removed.

Note: Refer to your console operating instructions for specific information regarding its addressing requirements.

Program a DMX or Virtuoso starting address:

- Step 1. Press [Menu].
- Step 2. Press [Up] / [Down] arrows until **ADDR** (Address) appears. Press [Enter].
- Step 3. Press [Up] / [Down] arrows to access **DMX** (DMX console control) or **VIRT** (Virtuoso console control). Press [Enter].
- Step 4. Press [Up] / [Down] arrows to enter starting address.
- Step 5. Press [Enter] to set.

Program Starting Address Without Calibrating the Luminaire

It is possible to bypass the calibration sequence and go directly to the Menu Display programming in order to pre-program an address setting.

Program starting address without calibrating luminaire:

- While powering up luminaire, press and hold [Menu]. Program address as in Program Starting Address above.

Note: The luminaire will require a reset to restore control.

Notes



CHAPTER 3.

Operation

This chapter contains instructions for operating the luminaire using DMX control and for updating the internal software.

- **Color/Gobo Control**
- **DMX Modes**
- **DMX Mapping**
- **Luminaire Timing**
- **Updating Software**

Color/Gobo Control

Color/Gobo Wheel Positions

The standard configurations for color and fixed gobo wheels are: all color filters installed on Wheel 1 (wheel nearest lamp) and all gobos installed on Wheel 2 (wheel nearer to front lens). These wheels each have 12 positions, one being open.

All rotating gobos are installed on the Rotating Gobo Wheel (nearest to front lens). This wheel has six positions, one being open.

Color and gobo wheels offer partial frame control and various spin rates in either direction.

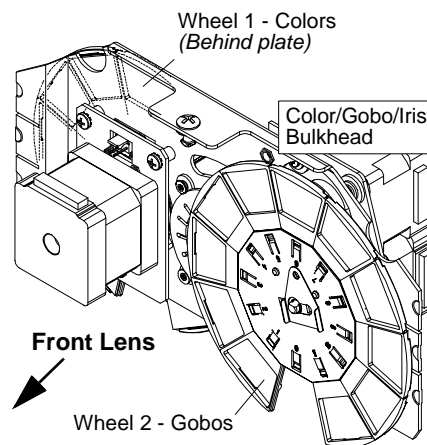

Standard Colors and Gobos

The following illustrations show the color and gobo standard configurations.

Standard Colors - Wheel 1 (Color Wheel)

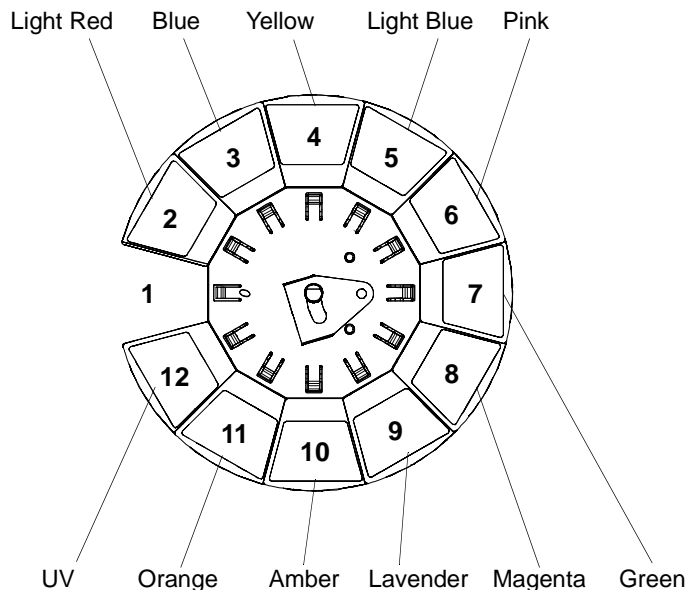

Standard Gobos - Wheel 2 (Fixed Gobo Wheel)

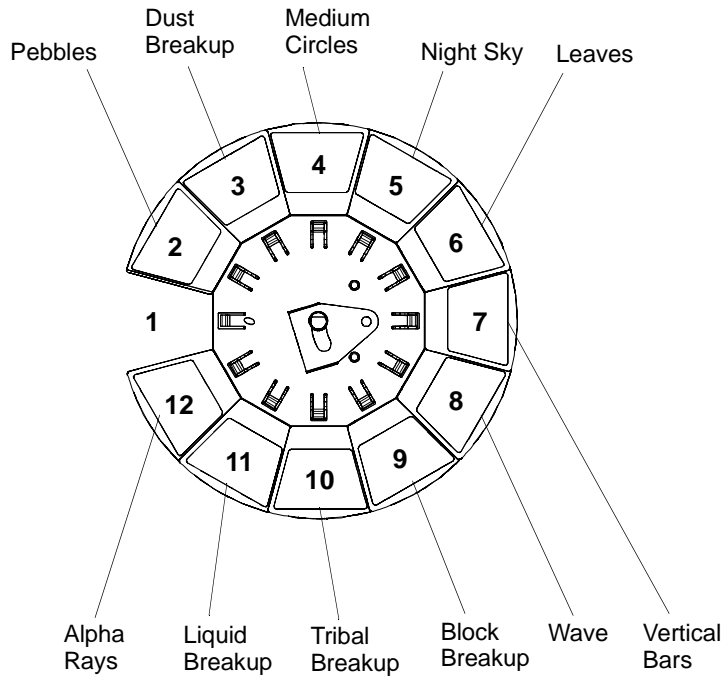

Standard Rotating Gobos

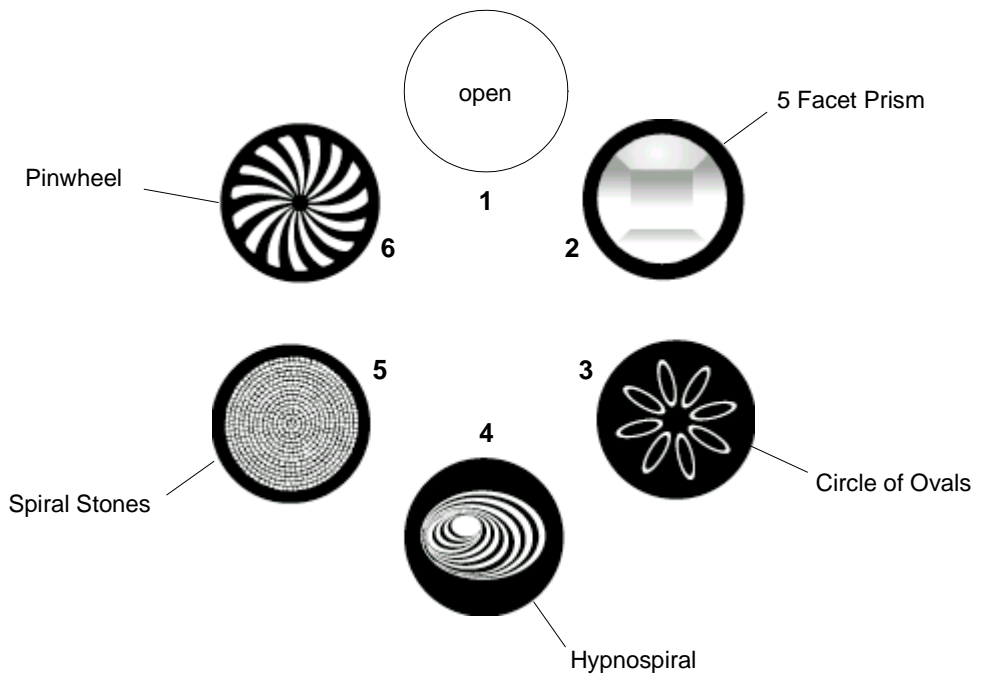

DMX Modes

8-Bit and 16-Bit Modes

These tables assume a DMX start address of 1. When a different starting address is used, this address becomes channel 1 function and other functions follow in sequence.

Standard 8-Bit (8)

Function	DMX Channel
Intensity	1
Pan	2
Tilt	3
Fixed Gobo	4
Color	5
Iris	6
Edge	7
Strobe	8
Zoom	9
Rot Wheel	10
Gobo Index	11
Control	12

Standard 16-Bit (16)

Function	DMX Channel
Intensity	1
Pan	2 - 3
Tilt	4 - 5
Fixed Gobo	6
Color	7
Iris	8
Edge	9
Strobe	10
Zoom	11
Rot Wheel	12
Gobo Index	13
Control	14

Enhanced 8-Bit (E 8)

Function	DMX Channel
Intensity	1
Pan	2
Tilt	3
Fixed Gobo	4
Color	5
Iris	6
Edge	7
Strobe	8
Zoom	9
Rot Wheel	10
Gobo Index	11
Focus Timing	12
Color Timing	13
Beam Timing	14
Control	15

Enhanced 16-Bit (E 16) - Default

Function	DMX Channel
Intensity	1
Pan	2 - 3
Tilt	4 - 5
Fixed Gobo	6
Color	7
Iris	8
Edge	9
Strobe	10
Zoom	11
Rot Wheel	12
Gobo Index	13
Focus Timing	14
Color Timing	15
Beam Timing	16
Control	17

DMX Mapping

Color/Gobo Wheels

Table 3-1: DMX Map for Color/Fixed Gobo Wheels

% Value	DMX (0-255)	Wheel Position	% Value	DMX (0-255)	Wheel Position
0	0	Open Frame 1		29	
	1			30	
	2		12	31	
1	3			32	
	4		13	33	
2	5			34	
	6			35	Full Frame 3
	7		14	36	
3	8			37	
	9	Half Frame	15	38	
4	10			39	
	11			40	
	12		16	41	
5	13			42	
	14		17	43	
6	15			44	Half Frame
	16			45	
	17	Full Frame 2	18	46	
7	18			47	
	19		19	48	
8	20			49	
	21			50	
	22		50	51	
9	23			52	
	24			53	Full Frame 4
10	25		21	54	
	26	Half Frame		55	
	27		22	56	
11	28			57	

Table 3-1: DMX Map for Color/Fixed Gobo Wheels (Continued)

% Value	DMX (0-255)	Wheel Position	% Value	DMX (0-255)	Wheel Position
	58			91	
23	59		36	92	
	60			93	
24	61		37	94	
	62	Half Frame		96	
	63		38	97	
25	64			98	Half Frame
	65		39	99	
26	66			100	
	67			101	
	68		40	102	
27	69			103	
	70			104	
28	71	Full Frame 5	41	105	
	72			106	
	73		42	107	Full Frame 7
29	74			108	
	75			109	
30	76		43	110	
	77			111	
	78		44	112	
31	79			113	
	80	Half Frame		114	
	81		45	115	
32	82			116	Half Frame
	83		46	117	
33	84			118	
	85			119	
	86		47	120	
34	87			121	
	88		48	122	
35	89	Full Frame 6		123	
	90			124	

Table 3-1: DMX Map for Color/Fixed Gobo Wheels (Continued)

% Value	DMX (0-255)	Wheel Position	% Value	DMX (0-255)	Wheel Position
49	125	Full Frame 8	62	158	
	126			159	
	127			160	
50	128		63	161	Full Frame 10
	129			162	
51	130		64	163	
	131			164	
	132			165	
52	133		65	166	
	134	Half Frame		167	
53	135		66	168	
	136			169	
	137			170	Half Frame
54	138		67	171	
	139			172	
55	140		68	173	
	141			174	
	142			175	
56	143	Full Frame 9	69	176	
	144			177	
57	145			178	
	146		70	179	Full Frame 11
	147			180	
58	148		71	181	
	149			182	
59	150			183	
	151		72	184	
	152	Half Frame		185	
60	153		73	186	
	154			187	
	155			188	Half Frame
61	156		74	189	
	157			190	

Table 3-1: DMX Map for Color/Fixed Gobo Wheels (Continued)

% Value	DMX (0-255)	Wheel Position	% Value	DMX (0-255)	Wheel Position
75	191		88	224	
	192			225	Spin M CCW
	193			226	
76	194		89	227	
	195			228	
77	196			229	
	197	Full Frame 12	90	230	
	198			231	
78	199		91	232	
	200			233	Spin S CCW
79	201			234	Stop
	202		92	235	Stop
	203			236	Stop
80	204		93	237	Spin S CW
	205			238	
	206	Half Frame		239	
81	207		94	240	
	208			241	
82	209		95	242	
	210			243	
	211			244	
83	212		96	245	
	213			246	Spin M CW
84	214		97	247	
	215			248	
	216	Spin F CCW		249	
85	217		98	250	
	218			251	
86	219		99	252	
	220			253	
	221			254	
87	222		100	255	Spin F CW
	223				

Rotating Gobo Index/Rotation

Table 3-2: DMX Map for Rotating Gobo Index/Rotation

% Value	DMX (0-255)	Wheel Position
0-84	0-215	Index Position
85	216	Fast Spin CW
86-90	217-232	Variable Rates
91	233	Slow Spin CW
92	234-237	Stop
93	238	Slow Spin CCW
94-99	239-254	Variable Rates
100	255	Fast Spin CCW

Rotating Gobo Wheel

Table 3-3: DMX Map for Rotating Gobo Wheel

% Value	DMX (0-255)	Action
0	0	Position 1 (Open)
20	51	Position 2
40	102	Position 3
60	153	Position 4
80	204	Position 5
100	255	Position 6

Beam Control

Beam Iris

Table 3-4: DMX Map for Beam Iris

% Value	DMX Value	Action
0	0	Closed
100	255	Open

Edge

Table 3-5: DMX Map for Edge

% Value	DMX Value	Action
0	0	Blooms In
100	255	Blooms Out

Strobe

Table 3-6: DMX Map for Strobe

% Value	DMX Value	Action
0	0-2	Open
1	3-5	Closed
2	6-7	Slow Random
3	8-10	Med Random
4	11-12	Fast Random
5-100	13-255	Speed Range

Zoom

Table 3-7: DMX Map for Zoom

% Value	DMX Value	Action
0	0	Narrow
100	255	Wide

Luminaire Timing

Luminaire Timing Channel Information

Timing channel control improves the timed moves of certain groups of parameters. We provide three timing channels, one for Focus (Pan and Tilt), one for color parameters and one for beam parameters. Timing channels support time values of up to six minutes.

Table 3-8: Channel Function / Timing Channel Relationship

Channel Function	Timing Channel		
	Focus Time	Color Time	Beam Time
Pan (Hi Byte/Lo Byte)	◆		
Tilt (Hi Byte/Lo Byte)	◆		
Color		◆	
Gobo			◆
Rotating Gobo			◆
Index			◆
Iris			◆
Edge			◆
Zoom			◆

A timing value of zero is full speed. A time value of 100% (or 255 in DMX) causes the associated parameter(s) to follow cue fade time (console time) rather than the timing channel.

Note: The particular storing syntax for your console, as well as instructions on how to write part cues, can be found in the operation manual for that console.

To use these channels, you must:

- Step 1. Create the cue, including color, gobo, edge and diffusion as required.
- Step 2. Decide which fixtures and which parameter groups will use timing channels.
- Step 3. Assign a value to the particular timing channel(s) you wish to use (for timing information see chart on next page).
- Step 4. Set console timing (or cue fade time) for parameters and timing channels to zero seconds.
- Step 5. Store cue.

Note: Avoid changing timing channel values in a fading cue. This can cause unexpected behavior in the luminaire as the timing channel value is updated over time. Timing channel values and the final destination of the parameters affected by the timing channel should always be sent in a zero count.

Timing channels can be set in either % or 0-255 (DMX) modes, with the following values assigned:

Table 3-9: Timing Channels Map

% Value	DMX	= Seconds
	0	Full Speed
	1	0.2
	2	0.4
1	3	0.6
	4	0.8
2	5	1
	6	1.2
	7	1.4
3	8	1.6
	9	1.8
4	10	2
	11	2.2
	12	2.4
5	13	2.6
	14	2.8
6	15	3
	16	3.2
	17	3.4
7	18	3.6
	19	3.8
8	20	4
	21	4.2
	22	4.4
9	23	4.6
	24	4.8
10	25	5
	26	5.2
	27	5.4
11	28	5.6
	29	5.8
	30	6

Table 3-9: Timing Channels Map (Continued)

% Value	DMX	= Seconds
12	31	6.2
	32	6.4
13	33	6.6
	34	6.8
	35	7.0
14	36	7.2
	37	7.4
15	38	7.6
	39	7.8
	40	8
16	41	8.2
	42	8.4
17	43	8.6
	44	8.8
	45	9
18	46	9.2
	47	9.4
19	48	9.6
	49	9.8
	50	10
20	51	10.2
	52	10.4
	53	10.6
21	54	11
	55	11
22	56	12
	57	12
	58	13
23	59	13
	60	14
24	61	14
	62	14
	63	15
25	64	15
	65	16
26	66	16
	67	16
	68	17
27	69	17
	70	18
28	71	18

Table 3-9: Timing Channels Map (Continued)

% Value	DMX	= Seconds
	72	18
	73	19
29	74	19
	75	20
30	76	20
	77	20
	78	21
31	79	21
	80	21
	81	22
32	82	22
	83	23
33	84	23
	85	23
	86	24
34	87	24
	88	25
35	89	25
	90	25
	91	26
36	92	26
	93	27
37	94	27
	95	27
	96	28
38	97	28
	98	29
39	99	29
	100	29
	101	30
40	102	30
	103	30
	104	31
41	105	31
	106	32
42	107	32
	108	32
	109	33
43	110	33
	111	34
44	112	34

Table 3-9: Timing Channels Map (Continued)

% Value	DMX	= Seconds
	113	34
	114	35
45	115	35
	116	36
46	117	36
	118	36
	119	37
47	120	37
	121	38
48	122	38
	123	38
	124	39
49	125	39
	126	39
	127	40
50	128	40
	129	41
51	130	41
	131	41
	132	42
52	133	42
	134	43
53	135	43
	136	43
	137	44
54	138	44
	139	45
55	140	45
	141	45
	142	46
56	143	46
	144	47
57	145	47
	146	47
	147	48
58	148	48
	149	49
59	150	49
	151	49
	152	50
60	153	50

Table 3-9: Timing Channels Map (Continued)

% Value	DMX	= Seconds
	154	50
	155	51
61	156	51
	157	52
62	158	52
	159	52
	160	53
63	161	53
	162	54
64	163	54
	164	54
	165	55
65	166	55
	167	56
66	168	56
	169	56
	170	57
67	171	57
	172	58
68	173	58
	174	58
	175	59
69	176	59
	177	59
	178	60
70	179	60
	180	65
71	181	65
	182	65
	183	70
72	184	70
	185	75
73	186	75
	187	75
	188	80
74	189	80
	190	85
75	191	85
	192	85
	193	90
76	194	90

Table 3-9: Timing Channels Map (Continued)

% Value	DMX	= Seconds
	195	95
77	196	95
	197	95
	198	100
78	199	100
	200	110
79	201	110
	202	110
	203	120
80	204	120
	205	120
81	206	130
	207	130
	208	140
82	209	140
	210	140
	211	150
83	212	150
	213	160
84	214	160
	215	160
	216	170
85	217	170
	218	180
86	219	180
	220	180
	221	190
87	222	190
	223	200
88	224	200
	225	200
	226	210
89	227	210
	228	210
	229	220
90	230	220
	231	230
91	232	230
	233	230
	234	240
92	235	240

Table 3-9: Timing Channels Map (Continued)

% Value	DMX	= Seconds
	236	250
93	237	250
	238	250
	239	260
94	240	260
	241	270
95	242	270
	243	270
	244	280
96	245	280
	246	290
97	247	290
	248	290
	249	300
98	250	300
	251	310
99	252	310
	253	310
	254	310
100	255	Follows Cue Data

Control Channel Functions

The following control actions must be accomplished with zero time transition or with timing disabled. Discrete values must be used and not manual controls such as faders or encoders.

Table 3-10: Control Channel Functions

Control Channel Function	Control Channel Value		
	% Value	For 3 Secs or Greater	After 3 Secs
Display On	1	1-4	0
Luminaire Reset	33	81 - 87	0
Lamp Off	66	165 - 171	0
Lamp On	99	249 - 255	0

To use control channel functions:

- Step 1. Select an action to be sent.
- Step 2. Set control channel value for desired action (for example, 84 for reset). Hold value for 3 seconds.

Note: A numerical keypad is required for sending values. An encoder or fader does not allow for a “snap” value change, which is required to affect the control functions.

- Step 3. Set control channel value to zero. (This must occur without any scaling values. Action will be voided if other values are detected between action value and zero.)

Updating Software

Reprogramming Luminaires

In some cases, it may be desirable to upgrade the luminaire's operating software. This process will require a Windows PC, the Luminaire Programming Kit (28.9661.0054), and the *VLDownload.exe* program. The *VLDownload.exe* program is available on the VL Download Installer Disk (87.7303.00xx)* or by downloading the *Series 1000™ and 2000™ Software Installer.exe* from the Vari-Lite website: www.vari-lite.com (follow the Support link to the Product Downloads page).

* xx = latest version, please call

The *VL Download.exe* program easily transfers new versions of software to any luminaires connected to the PC.

Note: Up to 32 luminaires can be programmed at the same time if they are data linked together. Refer to [“Connecting Data and Power” on page 19](#). (Programming more than 32 luminaires will require programming in batches of 32 or less.)

Luminaire Programming Kit (28.9661.0054) components:

- 6-Ft. Serial Straight Thru DB9M-F Cable (46.6033.0006)
- RS-232 to RS-485 Interface Converter (46.6036.0001)
- 6-Ft. RJ45 to 5-Pin Female XLR Cable (25.9661.0055)

Computer System Requirements:

- PC computer running Windows 95/98, Windows NT (4.0 or higher), or Windows 2000. (Program is not compatible with Macintosh computers.)
- Serial communication port. (RS-232 only, USB not supported.)

Hardware Setup Procedure:

Step 1. Assemble cable components (included in Luminaire Programming Kit) by connecting *Serial Straight Thru Cable* and *RJ45-to-XLR cable* to Interface Converter.

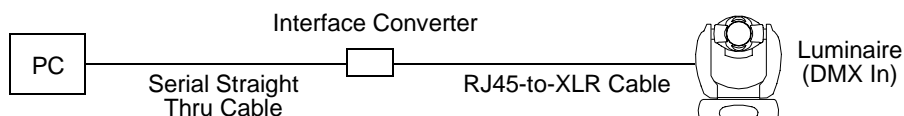

Step 2. Connect *Serial Straight Thru cable* to serial Comm Port of PC and connect *RJ45-to-XLR cable* to DMX In connector of luminaire.

Step 3. Apply power to PC and luminaire(s).

Install and Reprogramming Procedure

This procedure will install the *VLDownload.exe* program onto the PC and then allow you to reprogram the luminaires.

Note: If running Windows NT, you must be working from an account in the Administrators group to install the *VLDownload.exe* program onto the computer.

Install *VLDownload.exe* program using Programming Disk:

- Step 1. Insert VL Download Installer Disk into appropriate drive.
- Step 2. Run *Setup.exe*.
- Step 3. A confirmation window will appear. Click **Yes** to proceed with installation. (Installation process will begin. *VLDownload.exe* program will be installed onto PC and an Icon will be added to Desktop and Start menu Programs list.)

Install *VLDownload.exe* program from Vari-Lite website:

- Step 1. From PC that will be used to operate software, connect to Product Downloads page at www.vari-lite.com.
- Step 2. Download *Series 1000™ and 2000™ Software Installer.exe* program.
- Step 3. Run *WebSetup.exe*.
- Step 4. A confirmation window will appear. Click **Yes** to proceed with installation. (Installation process will begin. *VLDownload.exe* program will be installed onto PC and an Icon will be added to Desktop and Start menu Programs list.)

Update luminaire software:

- Step 1. Run *VLDownload.exe* program by double-clicking its desktop Icon, selecting from Start menu Programs list, or by selecting from C:\ProgramFiles\Vari-Lite\VL Download Program directory. (Luminaire Software Download window will open.)
- Step 2. At **Select Comm Port** section of window, select serial Comm Port (Comm Port 1, Comm Port 2, Comm Port 3, or Comm Port 4) where *Serial Straight Thru Cable* is connected.

Note: DMX Data must be disconnected before downloading to luminaires. (Do not merge with DMX signal.)



Step 3. At Select Software to Download section of window, select required luminaire software version to download by clicking its button or select Download All. (Software version is identified by the date and time: MM/DD/YY HH.MM.) The buttons function as follows:

- Choice 1 ➡ **VL2000Spot** button downloads the software to all VL2000 spot luminaires.
- Choice 2 ➡ **VL2000Wash** button downloads the software to all VL2000 wash luminaires.
- Choice 3 ➡ **VL1000** button downloads the software to all VL1000 ERS luminaires.
- Choice 4 ➡ **Download All** button is the equivalent of executing all of the specific software version buttons described above. They will be executed one at a time in the order they appear in the window. This button can be used when any combination of VL1000 or VL2000 luminaires are connected to the PC.

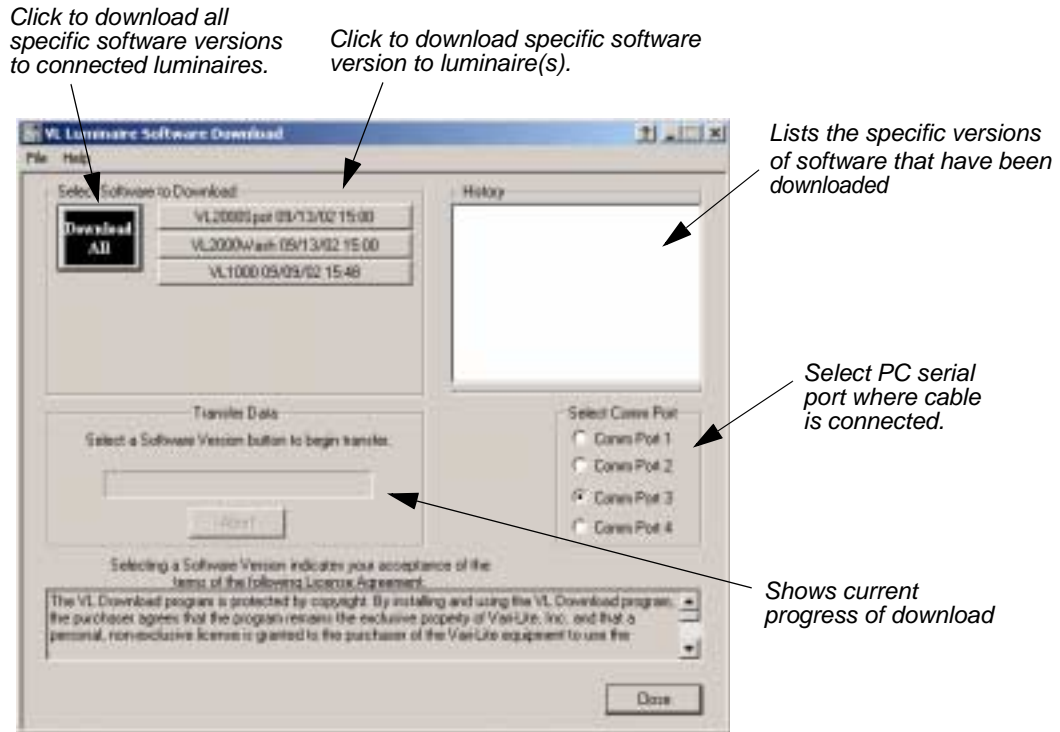
Note: Version dates shown in this graphic are for illustration purposes only and may not correspond to the version you are downloading.



Step 4. Download will proceed. One of the following will occur:

- Correct**  Luminaire's green Rx LED will blink rapidly and its menu will display number of blocks received (this number will vary depending on software version being downloaded). This indicates that data is being sent from PC to luminaire. However, if display does not show blocks as they are received, this indicates that the version being downloaded matches the one already installed or that the luminaire type does not match.
- Trouble**  If luminaire's green Rx LED does not blink rapidly and its menu does not display blocks, this indicates that no data is being received. (Check cable connections, port selection, etc. and try again.)

Note: Without any data connected, the normal standby cycle of the Rx LED is 2 sec on, 2 sec off.

Step 5. Once download is complete, luminaire will automatically recalibrate. Once recalibration is complete, luminaire is ready for operation with its new software version.

Step 6. Click **Close** to exit.

Note: The **History** section of the window shows what specific types of luminaire software have been downloaded since the beginning of the session (window will reset once the program is closed and re-opened).

Verify software version at luminaire:

Step 1. At Menu Display, press [Menu].

Step 2. Press [Up] / [Down] arrows until **Fixture** appears. Press [Enter].

Step 3. Press [Up] / [Down] arrows until **Version** appears. Press [Enter].

The first half of the version date will be displayed as MM.DD. (month.day):
For example, **07.21.** = July 21

Press [Up] / [Down] arrows to display second half of version date.

The second half of the version date will be displayed as YY.TT (year.time):
For example, **00.XX** = Year 2000, XX timecode

Transferring Software From Luminaire to Luminaire

It is possible to transfer specific software versions between luminaires. As in the case of installing new software versions, multiple luminaires can be programmed at the same time if they are data linked together (refer to [“Connecting Data and Power” on page 19](#)), however a maximum of 32 luminaires can be updated at once.

The transfer process can be used to download an earlier or later version of the VL2000 Luminaire Software to other connected luminaires of the same type.

Hardware Requirements

Data cables used in this process must have two twisted pairs and a shield. It is also recommended that cables meet all other USITT DMX specification requirements. Refer to [“Data Cables” on page 12](#).

Loopback and termination connectors are used in this process. Refer to [page 14](#) for more information regarding the construction of these connectors.



Transfer Procedure

This procedure is used to transfer software versions between VL2000 series luminaires of the same type.

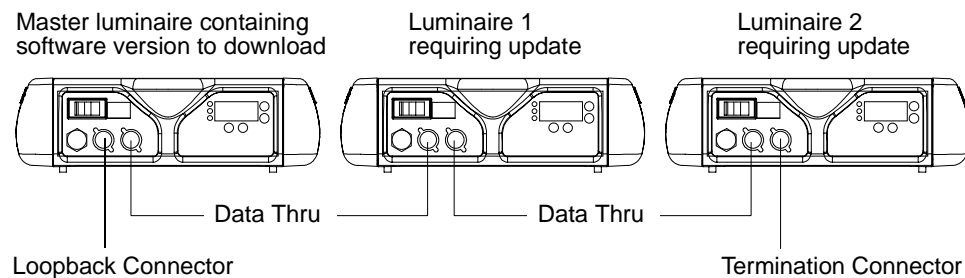
- Step 1. At master luminaire (first in link), install loopback connector into DATA IN XLR connector.
- Step 2. At last luminaire, install male termination connector into DATA THRU XLR connector.



- Step 3. At master luminaire Menu Display, press [Menu].
- Step 4. Press [Up] / [Down] arrows until **FIXT** (Fixture) appears.
- Step 5. Press [Up] / [Down] arrows until **Dnld** (Download) appears. Press [Enter].
- Step 6. **OK?** will be displayed. Press [Enter] to accept.
- Step 7. Download will proceed. (Download will take 1-2 seconds.) One of the following will occur:

- Correct**  The receiving luminaire's green Rx LED will blink rapidly and its menu will display number of blocks received (this number will vary depending on software version being downloaded). This indicates that data is being sent from luminaire to luminaire. However, if display does not show blocks as they are received, this indicates that the version being downloaded matches the one already installed or that the luminaire type does not match.
- Trouble**  If the receiving luminaire's green Rx LED does not blink rapidly and its menu does not display blocks, this indicates that no data is being received. (Check cable connections, loopback connector, etc. and ensure ALL cabling is the 5-conductor type.)

Note: Without any data connected, the normal standby cycle of the Rx LED is 2 sec on, 2 sec off.

Note: The number of blocks displayed will be less in a luminaire-to-luminaire download than in a PC-to-luminaire download for the same software version.

Step 8. Once download is complete, luminaire will automatically recalibrate. Once recalibration is complete, luminaire is ready for operation with its new software version.

Verify software version at luminaire:

Step 1. At Menu Display, press [Menu].

Step 2. Press [Up] / [Down] arrows until **Fixt** (Fixture) appears. Press [Enter].

Step 3. Press [Up] / [Down] arrows until **Ver** (Version) appears. Press [Enter].

The first half of the version date will be displayed as MM.DD. (month.day):
For example, **07.21.** = July 21

Press [Up] / [Down] arrows to display second half of version date.

The second half of the version date will be displayed as YY.TT (year.time):
For example, **00.XX** = 2000 (XX is a timecode)

Notes



CHAPTER 4.

Menu System

This chapter contains instructions for operating the luminaire using the Menu Display feature.

- **Operation**
- **Mapping**
- **Cues and Sequences**
- **Self Tests**

Operation

What Is the Menu System?

The menu system is a programmable set of commands used to configure, address, operate, and test the luminaire. The menu system is controlled at the Menu Display available at the enclosure input panel.

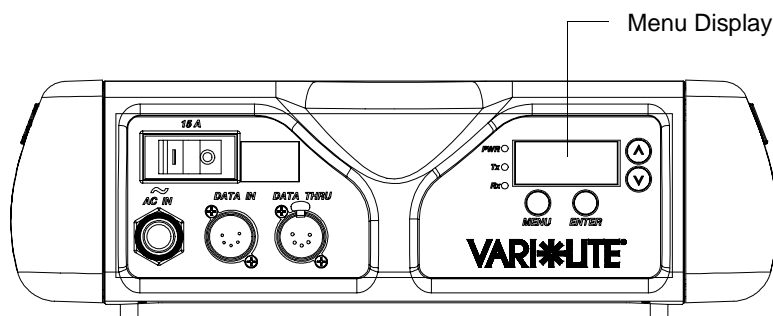

The menu system has seven main functions which are referred to as “1st level.” Within these main functions, there can be up to four additional sub-functions (levels 2 thru 5), making five total levels.

Controls Operation

The menu system is controlled by four buttons. These buttons function as follows:

[Menu] button. Displays the menu, or if at first level, the current address.

[Enter] button. Selects the current menu option or stores current data value.

[Up] arrow. Scrolls menu options upward or increases current data value.*

[Down] arrow. Scrolls menu options downward or decreases current data value.*

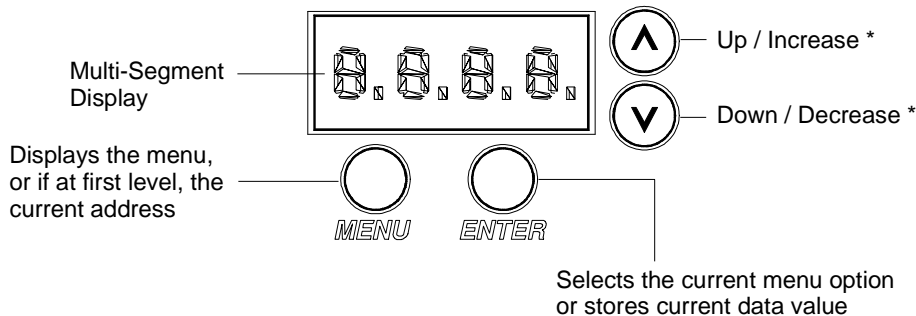

* The arrows will have opposite functions if luminaire is hung upside down in a hanging orientation and the Display Direction Orientation is “flipped.” Refer to [“Display Orientation” on page 53.](#)

To enter the menu system, first press [Menu]. The functions displayed will be 1st level functions. Scroll through the 1st level functions by pressing [Up] / [Down] arrows. Once the desired function appears in the display, press [Enter]. You are now at the 2nd level. Once again, press the [Up] / [Down] arrows to scroll through 2nd level functions. Press [Enter] to access 3rd level functions and so forth. When the highest level for the function is reached, [Up] / [Down] arrows can be pressed to select a value or select a toggle activation such as ON/OFF. Press [Enter] to store the value or select an action.

For example, the **Addr** (Address) function has two sub-levels: **DMX** and **VIRT** (Virtuoso). Both of these 2nd level menus allow access to a 3rd level, which is a value in both of these functions. The Address function is a 3-level menu.

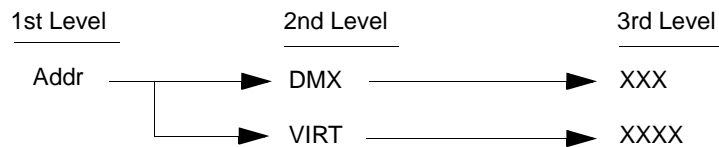

Display Orientation

To assist in reading the Menu System if the luminaire is installed in a hanging position, the display read-out orientation can be changed so that it still reads from left-to-right. Keep in mind that when the display read-out orientation is switched, the function of the [Up] / [Down] arrows are also switched respectively. In any case, when the display is in its readable orientation, the lower arrow button functions as down/decrease and the upper arrow button functions as up/increase.

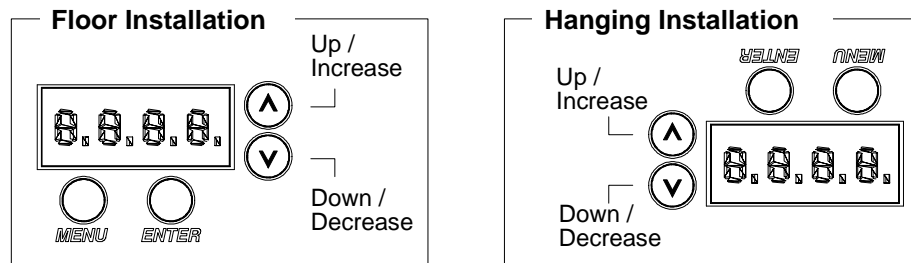

The default setting for the display orientation is **Auto**, which will automatically detect the orientation of the luminaire and adjust the display accordingly. However, a fixed orientation can also be programmed.

To program a fixed display read-out orientation:

- Step 1. Press [Menu].
- Step 2. Press [Up] / [Down] arrows until **CFG** (Configuration) appears. Press [Enter].
- Step 3. Press [Up]/ [Down] arrows to access **DDir**. Press [Enter].
- Step 4. Press [Up] / [Down] arrows to select ↑↑ or ↓↓. When desired direction is reached, press [Enter].

Default State

The menu display's default state during normal operation is to display the address (Virtuoso or DMX). After 10 seconds of inactivity at the display, it will change to the default state.

After longer periods of inactivity, the menu display will switch to its off state. The default state for this feature is 5 minutes, however, different time lengths can also be programmed.

To program a different time length for menu off feature:

Step 1. Press [Menu].

Step 2. Press [Up] / [Down] arrows until **CFG** (Configuration) appears. Press [Enter].

Step 3. Press [Up] / [Down] arrows to access **DisP** (Display). Press [Enter].

Step 4. Press [Up] / [Down] arrows to select either **30s** (30 sec.), **5M** (5 minutes), **10M** (10 minutes), or **ON** (on indefinitely). Press [Enter] to set.

Decimal Placement

A decimal to the right of a menu display readout can indicate two things:

- Virtuoso address - for example, **XXXX.**
- One of two pages - for example, the eight-digit luminaire ID number page 1: **XXXX.** and page 2: **XXXX**

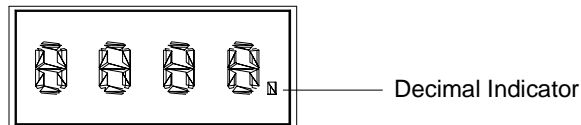

Display Test

The Display Test will display every character on the menu display to check for missing characters.

The following procedure is used to test the display.

Step 1. Press [Menu].

Step 2. Press [Up]/[Down] until **Test** appears. Press [Enter].

Step 3. Press [Up]/[Down] until **DISP** appears. Press [Enter]. All segments in the alpha-numeric display should be lit.

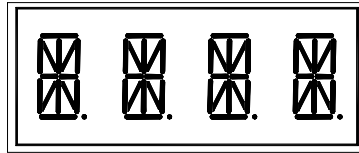

Shortcuts

A few button combinations are provided as shortcuts for frequently used menu functions. These shortcuts are as follows:

- Pressing [Enter] and [Up] at the same time = Lamp On
- Pressing [Enter] and [Down] at the same time = Lamp Off
- Pressing [Menu] and [Up] at the same time = Recalibrate
- Pressing [Menu] at Power up interrupts calibration. See [“Program Starting Address Without Calibrating the Luminaire”](#) on page 23 for more information.

Keep in mind that [Up] and [Down] arrows are dependent on the Display Orientation. Refer to [“Display Orientation”](#) on page 53.

Error Messages

If a problem occurs during luminaire calibration, at the end of the calibration sequence the Menu Display will cycle through any applicable error message(s), one a time until the end of the list is reached. To review the error messages again, it will be necessary to access them using the Status function. (Refer to “[Troubleshooting](#)” on page 84 for a list of possible causes and remedies associated with the error messages.)

To access error messages:

Step 1. Press [Menu].

Step 2. Press [Up] / [Down] arrows until **Fixt** (Fixture) appears. Press [Enter].

Step 3. Press [Up]/ [Down] arrows to access **STAT**. Press [Enter]. (Display will now scroll through any error messages or display **OK** if no errors.)

Table 4-1: Error Messages

Display	Message...
OK	No Errors Found
B1M1 / Whl2 / NoSn	Aux Board 1, Motor 1 / Wheel 2 / Sensor Not Found
B1M1 / Whl2 / SAct	Aux Board 1, Motor 1 / Wheel 2 / Sensor Always Active
B1M2 / Dimm / NoSn	Aux Board 1, Motor 2 / Dimmer / Sensor Not Found
B1M2 / Dimm / SAct	Aux Board 1, Motor 2 / Dimmer / Sensor Always Active
B1M3 / Whl1 / NoSn	Aux Board 1, Motor 3 / Wheel 1 / Sensor Not Found
B1M3 / Whl1 / SAct	Aux Board 1, Motor 3 / Wheel 1 / Sensor Always Active
B2M1 / Gobo / NoSn	Aux Board 2, Motor 1 / Rotating Gobo Wheel / Sensor Not Found
B2M1 / Gobo / SAct	Aux Board 2, Motor 1 / Rotating Gobo Wheel / Sensor Always Active
B2M2 / Indx / NoSn	Aux Board 2, Motor 2 / Rotating Gobo Index / Sensor Not Found
B2M2 / Indx / SAct	Aux Board 2, Motor 2 / Rotating Gobo Index / Sensor Always Active
BRD1 / NO / COMM	Aux Board 1 Communication Failure
BRD2 / NO / COMM	Aux Board 2 Communication Failure
LAMP / STRK / FAIL	Lamp Strike Failure
PAN / ENCR / FAIL	Pan Encoder Failure
PAN / NO / SENS	Pan Sensor Not Found
PAN / SENS / ACTV	Pan Sensor Always Active
SRCH/FOR/BRD1	Attempting to communicate with Board 1
SRCH/FOR/BRD2	Attempting to communicate with Board 2
TILT / ENCR / FAIL	Tilt Encoder Failure
TILT / NO / SENS	Tilt Sensor Not Found
TILT / SENS / ACTV	Tilt Sensor Always Active
WAIT	Retrieving Current Status
WRNG / SW / PROG	Wrong Software Program

Mapping

Menu System Overview

The following is a graphic representation of the entire menu system.

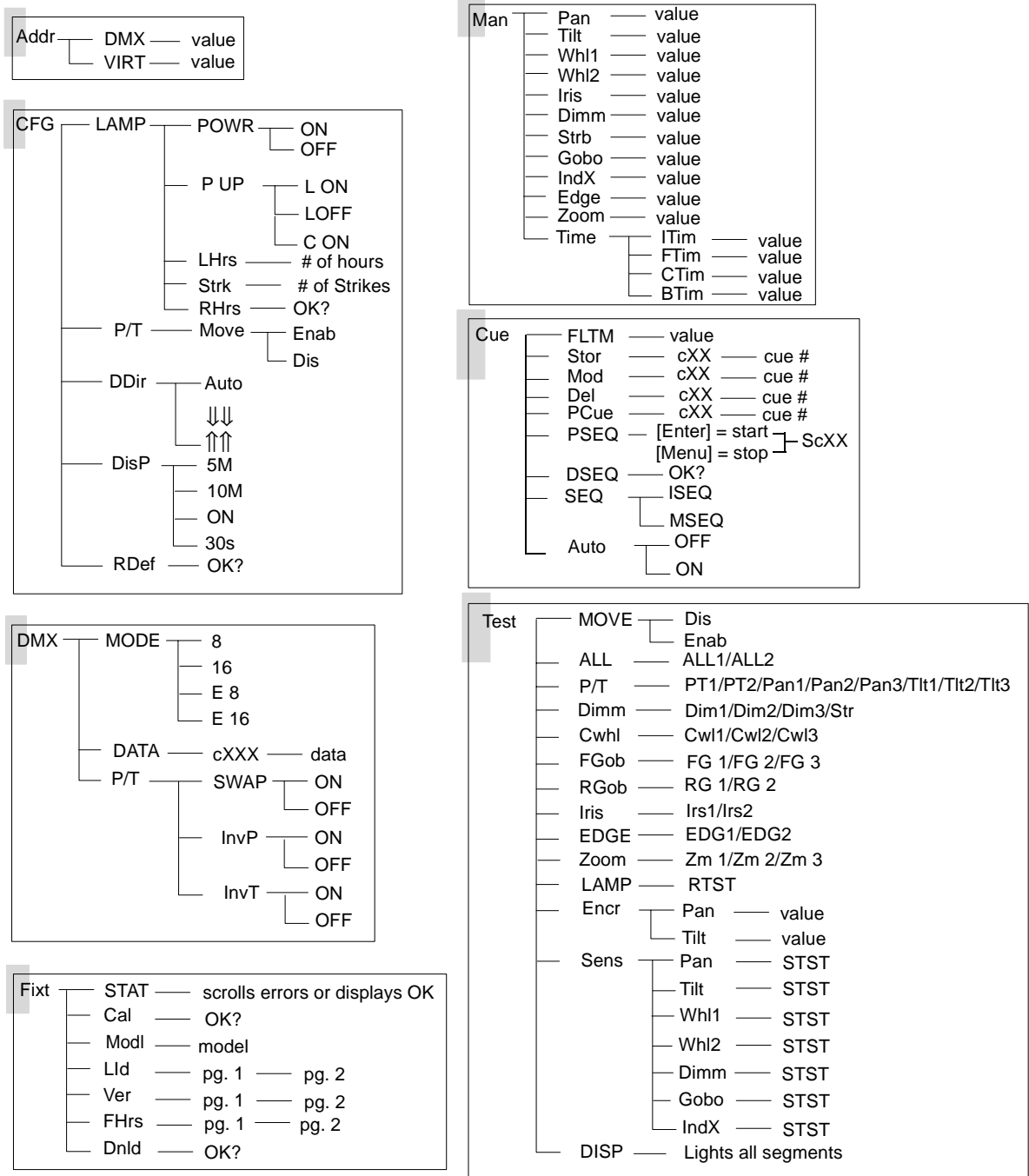

Menu System Functions

Table 4-2: Menu System Functions

1st Level	2nd Level	3rd Level	4th Level	5thLevel
Addr Address	DMX DMX Address	XXX Address value		
	VIRT Virtuoso Address	XXXX. Address value		
CFG System Configuration	LAMP Lamp Options	POWR Lamp Power	ON (default) OFF	
		P UP Lamp Power-up State	L ON Lamp On (default) LOFF Lamp Off	
			C ON On after Calibration	
			LHrs Lamp Hours Used	XXXX Cumulative # of Operation Hours (Not editable)
		Strk # of Lamp Strikes	XXXX # of Strikes (not editable)	
		RHrs Reset Lamp Hour and Lamp Strike Counters	OK?	
		P/T Pan and Tilt Options	Move Position Recovery	Enab Enable
	Dis Disable			
	DDir Display Orientation	Auto (default) ↓↓↓ ↑↑↑		
	DisP Display Illumination	30s OFF in 30 seconds 5M OFF in 5 minutes (default) 10M OFF in 10 minutes ON ON indefinitely		
	RDef Reset Default Values	OK?		
	DMX DMX Mode and Data	MODE	8 Standard 8 bit	
16 Standard 16 bit (default)				
E 8 Enhanced 8 bit				
E16 Enhanced 16 bit				
DATA		cXXX DMX Channel	XXXX Data	
P/T Pan/Tilt Options		SWAP Swap Pan & Tilt	ON	
			OFF (default)	
		InvP Invert Pan	ON	
			OFF (default)	
		InvT Invert Tilt	ON	
	OFF (default)			

Table 4-2: Menu System Functions (Continued)

1st Level	2nd Level	3rd Level	4th Level	5thLevel	
Fixt	STAT Status/Error Display	Scrolls error messages * or displays OK			
	Cal Recalibrate	OK?			
	Modl Luminaire Model Type	XXXX Model Type			
	Lld Luminaire ID	XXXX . Luminaire ID Number (Page 1)	XXXX Luminaire ID Number (Page 2)		
	Ver Version	XX.XX . Version (Page 1)	XX.XX Version (Page 2)		
	FHrs Fixture Hours On	XXXX Hours			
	Dnld Download Program to Luminaires	OK?			
Man Manual Commands	Pan Pan Motor	XXXX Data			
	Tilt Tilt Motor	XXXX Data			
	Whl1 Wheel 1 (Color)	XXX Data			
	Whl2 Wheel 2 (Gobo)	XXX Data			
	Iris Iris	XXX Data			
	Dimm Dimmer	XXX Data			
	Strb Strobe	XXX Data			
	Gobo Rotating Gobo Select	XXX Data			
	Indx Rotating Gobo Index	XXX Data			
	Edge Edge	XXX Data			
	Zoom Zoom	XXX Data			
	Time Timing Data	ITim Dimmer/Intensity Time	XXX.X Data		
		FTim Focus Time	XXX.X Data		
		CTim Color Time	XXX.X Data		
BTim Beam Time		XXX.X Data			
Cue Cue Processing	FLTM Follow Time	XXX.X Data			
	Stor Store Cue	XX Cue # to Store (Not editable – given next cue ID in list)			
	Mod Modify Cue	XX List of Cues			
	Del Delete Cue	XX Cue # to Delete (Not editable – given last cue ID in list)			
	PCue Play Cue	XX List of Cues			
	PSEQ Play Sequence	Press [Enter] to start Press [Menu] to stop			
	DSEQ Delete Sequence	OK?			
	SEQ Sequence Playback Mode	ISEQ Individual Sequence (default)			
		MSEQ Master Sequence			
	Auto Autoplay at Power-Up	OFF (default)			
ON					

* Refer to “Error Messages” on page 56.

Table 4-2: Menu System Functions (Continued)

1st Level	2nd Level	3rd Level	4th Level	5thLevel
Test* System Test	MOVE Pan/Tilt Control	Dis Disable	Press [Menu] to stop tests	
		Enab Enable		
	ALL Test All Motors	ALL1 All Synchronized Test		
		ALL2 All Test		
	P/T Pan/Tilt	PT 1 Min/Max Fast Pan/Tilt test		
		PT 2 Min/Max SlowPan/Tilt test		
		Pan1 Min/Max Fast Pan Test		
		Pan2 Min/Max Slow Pan Test		
		Pan3 Pan Test		
		Tilt1 Min/Max Fast Tilt Test		
		Tilt2 Min/Max Slow Tilt Test		
		Tilt3 Tilt Test		
	Dimm Dimmer/Strobe	Dim1 Min/Max Dimmer Test		
		Dim2 Min/Max Dimmer Test		
		Dim3 Dimmer Test		
		Str Strobe Test		
	Cwh1 Color Wheel	Cw11 Color Wheel Test		
		Cw12 Color Wheel Test		
		Cw13 Color Wheel Test		
	FGob Fixed Gobo Wheel	FG 1 Fixed Gobo Wheel Test		
		FG 2 Fixed Gobo Wheel Test		
		FG 3 Fixed Gobo Wheel Test		
	RGob Rotating Gobo Wheel	RG 1 Rotating Gobo Wheel Test		
		RG 2 Rotating Gobo Wheel Test		
	Iris Iris	Irs1 Iris Test		
		Irs2 Iris Test		
	EDGE Egde	EDG1 Edge Test		
EDG2 Edge Test				
Zoom Zoom	Zm 1 Zoom Test			
	Zm 2 Zoom Test			
	Zm 3 Zoom Test			
LAMP Lamp	RTST			
Encr Encoders	Pan Pan Encoder		XXXX Data	
	Tilt Tilt Encoder		XXXX Data	

Table 4-2: Menu System Functions (Continued)

1st Level	2nd Level	3rd Level	4th Level	5thLevel
Test (cont.)*	Sens Sensors	Pan EOT Sensor	STST Sensor Test in Progress	PASS
		Tilt EOT Sensor	STST Sensor Test in Progress	PASS FAIL
		Whl1 Wheel 1 EOT Sensor	STST Sensor Test in Progress	PASS FAIL
		Whl2 Wheel 2 EOT Sensor	STST Sensor Test in Progress	PASS FAIL
		Dimm Dimmer/Strobe EOT Sensor	STST Sensor Test in Progress	PASS FAIL
		Gobo Gobo Select EOT Sensor	STST Sensor Test in Progress	PASS FAIL
		Indx Gobo Index EOT Sensor	STST Sensor Test in Progress	PASS FAIL
	DISP Display Test	X.X.X.X. Ignites all 14 segments of each of the 4 characters and all 4 decimal points.		

*Refer to [“Diagnostic Tests” on page 73](#) for more information.

Note: A decimal to the right of a menu display readout indicates either a Virtuoso address or that the page is 1 of 2. Refer to [“Decimal Placement” on page 54](#).

Function Definitions

Each menu item is listed in the first column by its display abbreviation. The abbreviations appear in alphabetical order as opposed to their position in the menu display sequence for easy reference.

Display	Definition	Purpose
8	Standard 8-bit	Configures luminaire for operation in standard DMX 8-bit mode.
16	Standard 16-bit	Configures luminaire for operation in standard DMX 16-bit mode.
10M	10 Minutes	Sets Menu Display to automatically shut off after 10 minutes of non-use.
30s	30 Seconds	Sets Menu Display to automatically shut off after 30 seconds of non-use.
5M	5 Minutes	Sets Menu Display to automatically shut off after 5 minutes of non-use.
Addr	Address	Accesses functions for setting luminaire starting address in either Virtuoso (VIRT) or DMX (DMX) controlled systems.
ALL	All Motors	Tests all internal motors.
Auto	Auto Detect or Auto Playback	Automatically detects required Menu Display orientation when selected (DDir) or initiates automatic playback of a cue sequence at power-up (CUE).
BTim	Beam Time	Accepts timing value for beam time.
C ON	On after Calibration	Configures arc luminaire so that lamp will strike after calibration procedure is complete.
Cal	Recalibrate	Recalibrates luminaire.
CFG	System Configuration	Accesses functions for setting lamp start up, pan/tilt, and Menu Display configurations. Also accesses lamp information such as number of strikes, and hours used, along with their respective reset function.
CTim	Color Time	Sets color time.
Cue	Cue Processing	Accesses cue store, modify, delete, and playback commands.
Cwhl	Color Wheel	Specifies Color wheel for testing.
cXXX	DMX Channel	Specifies DMX channel for display of current data value.
DATA	DMX Data	Accesses function for displaying DMX data by channel number.
DDir	Display Orientation	Accesses option to orient Menu display for reading correctly in either hanging or floor mounting installations.
Del	Delete Cue	Deletes cues by number. Cue number deleted is dependent on last cue ID in cue list since this field is not editable.

Display	Definition	Purpose
Dimm	Dimmer	Specifies dimmer mechanism for manual control (Man) or tests dimmer/strobe functions (Test).
Dis	Disable	Disables a function.
DISP	Display Test	Tests all 14 segments in the Display.
DisP	Display Illumination	Accesses options for Menu Display on and off times.
DMX	DMX	Accesses functions for setting DMX mode or pan/tilt options (1st level menu) or sets starting address for luminaire in DMX systems (Addr).
Dnld	Download	Downloads program to luminaires.
DSEQ	Delete Sequence	Deletes cue sequence.
E 16	Enhanced 16-bit	Configures luminaire for operation in enhanced DMX 16-bit mode.
E 8	Enhanced 8-bit	Configures luminaire for operation in enhanced DMX 8-bit mode.
Edge/ EDGE	Edge Motor	Specifies edge function for manual control or testing.
Enab	Enable	Enables a function.
Encr	Encoders	Accesses encoder choices for diagnostic testing.
FAIL	Test Fail	Indicates that sensor test has failed.
FGob	Fixed Gobo	Tests fixed wheel gobo function.
FHrs	Fixture Hours	Displays total number of hours luminaire has been powered on.
Fixt	Fixture	Access luminaire specification information such as model, serial number, software version, along with status information and download function.
FLTM	Follow Time	Accepts value for cue follow feature.
FTim	Focus Time	Accepts timing value for focus time.
Gobo	Gobo Select	Specifies rotating gobo select for manual control (Man) or gobo select EOT sensor for testing (Test).
Indx	Gobo Index	Specifies rotating gobo index for manual control (Man) or gobo index EOT sensor for testing (Test).
InvP	Invert Pan	Reverses pan action for special focus requirements.
InvT	Invert Tilt	Reverses tilt action for special focus requirements.
Iris	Iris Motor	Specifies iris mechanism for manual control or testing.
ISEQ	Individual Sequence	A sequence playback mode which will play the cues from each individual luminaire, if any. (In ISEQ, if the number of cues is different, it will only play as many as each luminaire has stored. The follow time is taken from the master luminaire.)

Display	Definition	Purpose
ITim	Intensity Time	Accepts timing value for intensity fade time.
L ON	Lamp is On	Configures arc luminaire so that lamp will strike upon power up.
LAMP	Lamp	Accesses lamp power up options and information (CFG) or sets beam for lamp alignment adjustment (TEST).
LHrs	Lamp Hours	Displays total number of lamp operating hours.
LId	Luminaire ID	Displays unique ID number for the luminaire which is used by Virtuoso consoles to identify the unit (in two pages).
LOFF	Lamp is Off	Configures arc luminaire so that lamp will await manual command before striking.
Man	Manual Commands	Accesses functions for controlling luminaire mechanisms and timing by entry of an absolute data value.
Mod	Modify Cue	Accepts cue number of cue to modify from cue list.
MODE	DMX Mode	Accesses functions for setting DMX mode to standard or enhanced 8-bit or 16-bit.
ModI	Model	Displays model number of luminaire. For example, 2413 (VL2413).
Move	Move	Enables and disables pan and tilt movement and auto-correction.
MSEQ	Master Sequence	A sequence playback mode which will replay the cues from the master luminaire.
NoPg	No Program	Indicates that there is no software present in the luminaire.
OFF	Off	Turns off a function.
OK	Okay	Indicates that luminaire is ready to accept commands.
OK?	Okay?	Prompt for pressing [Enter] before an action is executed.
ON	On Indefinitely	Sets Menu Display to stay on until programmed otherwise (DisP), turns on a function, or turns on a menu item.
P UP	Lamp Power Up	Accesses options for lamp power up: on, off, or after calibration.
P/T	Pan/Tilt	Accesses pan and tilt options for DMX function, system configuration, and testing.
Pan	Pan	Specifies pan function for manual control (Man) or pan encoder for testing (Test).
PASS	Test Pass	Indicates that sensor test has passed.
PCue	Play Cue	Accesses cue list for play back of cues by number.
POWR	Lamp Power	Accesses function to turn lamp on or off.
PSEQ	Play Sequence	Plays back cue sequence. Press [Enter] to start and [Menu] to stop.
RDef	Reset Default	Resets default system configuration values.
RGob	Rotating Gobo	Tests rotating gobo wheel.

Display	Definition	Purpose
RHrs	Reset Lamp Info	Resets lamp hour and lamp strike counters. For use when new lamp is installed.
RTST	Run-Test	Indicates that a system mechanism test is in progress.
Sens	Sensors	Accesses sensor choices for diagnostic testing.
SEQ	Sequence Playback	Sets sequence playback mode to Individual (plays cues from each luminaire) or Master (all luminaires play same cue).
STAT	Status/Error Display	Allows scrolling through error list or displays OK if no errors.
Stor	Store Cue	Stores cue by number. Cue number stored is dependent on next cue ID in cue list since this field is not editable.
Str	Strobe	Specifies strobe function for manual control.
Strk	Strike	Displays total number of lamp strikes.
STST	Sensor Test	Indicates that a system sensor test is in progress.
SWAP	Swap	Swaps pan and tilt functions for special focus requirements such as moving mirror mechanisms.
Test	System Tests	Accesses diagnostic tests for internal mechanisms.
Tilt	Tilt	Specifies tilt function for manual control (Man) or tilt encoder for testing (Test).
Time	Timing Data	Allows manual setting of timing values for dimmer/intensity, focus, color, and beam.
Ver	Version	Displays current software version (in two pages).
VIRT	Virtuoso console	Sets starting address for luminaire in Virtuoso systems.
Whl1	Wheel 1 (Color)	Specifies wheel 1 for manual control or testing.
Whl2	Wheel 2 (Fixed Gobo)	Specifies wheel 2 for manual control or testing.
Zoom	Zoom	Specifies zoom function for manual control or testing.

Cues and Sequences

Overview

The luminaire has the ability to store and playback cues independent of a console. Cues are stored as numbers from 1 to 99 by using the **Cue** (Cue Processing) functions available in the menu system. This also allows you to create your own test sequences to be played back on a group of luminaires.

Refer to [“Menu System Functions” on page 58](#) for a complete breakdown of **Cue** and **Man** (Manual Commands) functions.

Storing

The luminaire is able to store its current position into a cue; this information can be set via a console or by using the menu system **Man** (Manual Commands) function.

Playback

Cues can be joined into a sequence to be played back without a console. However, only one sequence can run at a time.

A sequence can either replay the cues stored in each luminaire or replay the cues stored in a master luminaire. Playing a cue sequence for all luminaires in the data link is triggered by a “master” luminaire using the **PSEQ** (Play Sequence) command. The cue follow time (**FLTM**) is taken from the luminaire that is running the sequence (it is possible to view the follow time of each cue by playing the cue **PCUE** and then viewing the cue follow time **FLTM**). A playback sequence can be set to start automatically after power up by setting the **Auto** (AutoPlay) feature to ON.

Note: Up to 32 luminaires can be linked together to run a sequence if they are data linked together. Refer to [“Connecting Data and Power” on page 19](#).

Hardware Requirements

Data cables used in the multi-luminaire playback feature must have two twisted pairs and a shield. It is also recommended that cables meet all other USITT DMX specification requirements. Refer to [“Data Cables” on page 12](#).

Loopback and termination connectors are used in this process. Refer to [page 14](#) for more information regarding the construction of these connectors.

Cue Operations

The following section provides instructions for performing cue, sequence, and playback operations.

Note: The **Mod, Del, PCue, PSEQ** commands will all display "---" if no cues have been stored.

Note: After 10 seconds of inactivity at the display, it will change to the default state showing the address.

To use the menus:

The data stored by the luminaire is “last takes precedence.” This means the last command received by the luminaire will be the basis of the cue to be stored.

To clear all input data and timing values from previous tests or cues, cycle power to the luminaire with DMX data cables disconnected. This will reset parameter’s data and timing values to defaults.

Set position:

- Step 1. Press [Menu].
- Step 2. Press [Up]/ [Down] arrows until **Man** appears. Press [Enter].
- Step 3. Press [Up]/ [Down] arrows until desired parameter appears. Press [Enter].
- Step 4. Press [Up] / [Down] arrows to adjust value. (The values wrap from 0 to 255 in either direction. Pan and Tilt values operate in a range of 0-4095, and wrap also.) Press [Enter] to set value.
- Step 5. Parameter timing can be set using the **Time** sub-functions. This allows timing to be added to Intensity, Pan & Tilt, Color, and Beam parameters.

Set follow time between cues:

The following procedure is used to set the follow time between each cue. The value can be different for each cue. The range is 0.0 to 365.9 seconds.

- Step 1. Press [Menu].
- Step 2. Press [Up] / [Down] arrows until **Cue** appears. Press [Enter].
- Step 3. Press [Up] / [Down] arrows until **FLTM** appears. Press [Enter].
- Step 4. Press [Up] / [Down] arrows to set value. Once the value is set press [Enter] button. The display will return to **FLTM**.

To store a cue:

- Step 1. Press [Menu].
- Step 2. Press [Up] / [Down] arrows until **Cue** appears. Press [Enter].
- Step 3. Press [Up] / [Down] arrows until **Stor** appears. Press [Enter]. The number displayed is the cue number to be stored.
- Step 4. Press [Enter] to store cue. (Number will increase by one for next cue to be stored.)
- Step 5. Repeat for remaining cues.

To delete a cue:

- Step 1. Press [Menu].
- Step 2. Press [Up] / [Down] arrows until **Cue** appears. Press [Enter].
- Step 3. Press [Up] / [Down] arrows until **Del** appears. Press [Enter]. The last cue number stored will be displayed and only the last cue will be deleted.
- Step 4. Press [Enter] to delete cue. (There is no “undo” function.)

To play a cue:

- Step 1. Press [Menu].
- Step 2. Press [Up] / [Down] arrows until **Cue** appears. Press [Enter].
- Step 3. Press [Up] / [Down] arrows until **PCue** appears. Press [Enter]. This allows the stored cues to be selected by using [Up] / [Down] arrows and then played by pressing [Enter]. (If there are no stored cues, “**C --**” will be displayed. If there is one or more cues, “**C xx**” will be displayed - where xx is the cue number from 1 to 99. Only cues in one luminaire will play.)

To edit or modify a cue:

- Step 1. Recall cue to be changed from **PCue**.
- Step 2. Change luminaire data to desired levels using **Man** (Manual Command) functions.
- Step 3. Press [Up] / [Down] arrows until **Cue** appears. Press [Enter].
- Step 4. Press [Up] / [Down] arrows until **Mod** appears. Press [Enter]. The number displayed is the same as the selected cue.
- Step 5. Press [Enter] and changes will be saved.

To play cues as a sequence:

- Step 1. Press [Menu].
- Step 2. Press [Up] / [Down] arrows until **Cue** appears. Press [Enter].
- Step 3. Press [Up] / [Down] arrows until **PSEQ** appears. Press [Enter] and the sequence will play. The active cue will be shown in the display. [Enter] to start, [Menu] to stop.

To change the follow time in a sequence:

The follow time is stored for each cue individually.

- Step 1. Select cue to be changed from **PCue**.
- Step 2. Go to **Mod** to modify active cue and press [Enter] to save the change.
- Step 3. Set **FLTM** (Follow Time) to desired value (refer to [“Set follow time between cues:” on page 67](#)).

To delete a sequence and all cues:

- Step 1. Press [Menu].
- Step 2. Press [Up] / [Down] arrows until **Cue** appears. Press [Enter].
- Step 3. Press [Up] / [Down] arrows until **DSEQ** appears. Press [Enter].
- Step 4. **OK?** prompt will appear. Press [Enter] to delete stored sequence.

Choose Sequence Mode:

MSEQ will replay the cues from the master luminaire.

ISEQ will play the cues from each individual luminaire, if any. In **ISEQ**, if the number of cues is different, it will only play as many as each luminaire has stored. The follow time is taken from the master luminaire.

- Step 1. Press [Menu].
- Step 2. Press [Up] / [Down] arrows until **Cue** appears. Press [Enter].
- Step 3. Press [Up] / [Down] arrows until **SEQ** appears. Press [Enter].
- Step 4. Press [Up] / [Down] arrows to toggle between **ISEQ** and **MSEQ**. Press [Enter] to select mode.

To make a sequence AutoPlay at power up:

- Step 1. Press [Menu].
- Step 2. Press [Up] / [Down] arrows until **Cue** appears. Press [Enter].
- Step 3. Press [Up] / [Down] arrows until **Auto** appears. Press [Enter].
- Step 4. Use [Up] / [Down] arrows to toggle between **OFF** (the default) and **ON**. Press [Enter] to select the mode.

To store cues from a console:

- Step 1. Clear memory by deleting cues or sequence, if required.
- Step 2. Recall cue at the console.
- Step 3. From **Cue** menu, set **FLTM**, then at **Stor** store cue. If each luminaire has separate data then store each cue into each luminaire. The sequence mode to use in this case would be **ISEQ**.

Self Tests

Running Parameter Tests

The luminaire is capable of running self tests by using the **TEST** menu functions. For complete details and values for each test refer to “[Diagnostic Tests](#)” on [page 73](#).

Note: After 10 seconds of inactivity, the menu display will change to the default state showing the address.

When running tests on multiple luminaires, a loopback connector is required at the master luminaire (first in link) and a male termination connector is required at the last luminaire in the link. (Refer to [page 14](#) for more information regarding the construction of these connectors.)

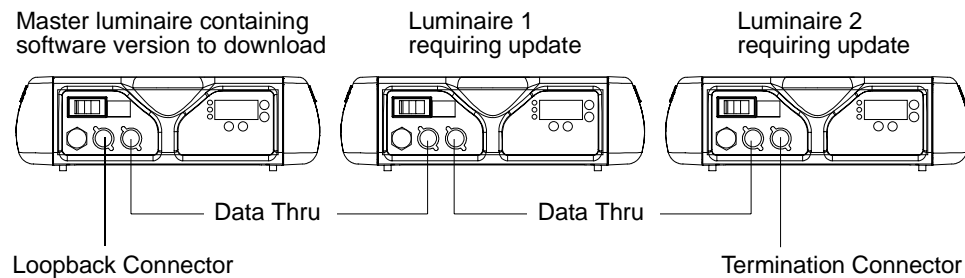

Move Disable

The **Move** option has been added to the test menu. This allows for pan/tilt functions to be disabled so that the luminaire can be placed in any position for testing without movement occurring. In order to regain full control of the luminaire, **Move** will need to be enabled after testing.

Note: When setting the **Move** option to disable, luminaires linked by a loopback connector will have pan and tilt disabled for all the luminaires that are linked.



WARNING: Backcap and adjustment knobs will be HOT during lamp operation. Wear gloves and/or use tools to prevent burns.

Lamp

The **Lamp** option has been added to the test menu. This option sets the lamp intensity to 100%, adjusts the iris and edge to produce a hard edge. See “[Align Lamp for Flat Field](#)” on page 21 for instructions on lamp adjustment. Pan/Tilt are disabled while using the **Lamp** option, and pan/tilt settings will be restored upon exit of the **Lamp** feature.

Note: When setting the **Lamp** option on luminaires linked by a loopback connector, pan and tilt will be disabled for all the luminaires that are linked.

To run tests:

- Step 1. Press [Menu].
- Step 2. Press [Up] / [Down] arrows until **TEST** appears. Press [Enter].
- Step 3. Use [Up] / [Down] arrows to select a parameter to test. Refer to “[Menu System Functions](#)” on page 58 for a complete list of test parameters which can be chosen.
- Step 4. Press [Enter] to run test.
- Step 5. Press [Menu] to stop test at any time.

Diagnostic Tests

The following diagnostic tests are available in the test menu. Time is specified for each action in the test, and the total time equals the time it takes to complete each action. If the time is zero the luminaire will perform the test at full speed.)For specific DMX values for each test see “Diagnostic Tests” on page 74.)

Test Descriptions

ALL1	Tests low voltage power supplies by moving all motors at once.
ALL2	Tests all functions and provides a burn in or soak test.
Cwl1	Steps through each position of color wheel to verify order. The test then performs a Max forward spin, stops, and performs a Max reverse spin.
Cwl2	Tests color wheel stabilizers. Performs Max reverse spin, stops on a color, and then stops on the sensor.
Cwl3	Test color wheel stabilizers. Steps through selected colors.
Dim1	Fast dimmer test from full to closed.
Dim2	Slow dimmer test from full to closed.
Dim3	Tests different dimmer moves.
EDG1	Fast edge test from min to max.
EDG2	Slow edge test from min to max.
FG1	Fixed gobo test. Steps through every gobo, performs a max forward spin and a max reverse spin.
FG2	Fixed gobo test. Performs a max reverse spin, stops on a gobo, and then stops on the sensor.
FG3	Fixed gobo test. Steps through selected gobos.
Irs1	Fast iris test. Goes from min to max.
Irs2	Slow iris test. Goes from min to max.
PT1	Fast pan and tilt from stop to stop.
PT2	Slow pan and tilt from stop to stop.
Pan1	Fast pan only test from stop to stop.
Pan2	Slow pan only test from stop to stop.
Pan3	Tests different pan movements.
RG1	Rotating gobo test. Goes through wheel positions.
RG2	Rotating gobo test. Goes through index and rotation positions.
Tlt1	Fast tilt only test from stop to stop.
Tlt2	Slow tilt only test from stop to stop.
Tlt3	Tests different tilt movements.
Str	Strobe test that tests 0-Open, 4-Closed, 11-Fast Random, 255-Max Strobe actions.
Zm 1	Slow zoom test.
Zm 2	Fast zoom test.
Zm 3	Tests different zoom movements.

The chart on the following page shows the 16-bit DMX values used in each test.

Table 4-5: Diagnostic Tests

Test Name	Parameters											
	Pan*	Tilt*	Dim	CWhl	F. Gobo	Iris	R. Gobo	Index	Edge	Zoom	Str	time/total time
ALL1	0	0	0	0	0	0	0	0	0	0	0	0/5
	65535	65535	255	255	255	255	255	255	255	255	255	0/5
ALL2	0	0	0	0	255	0	0	0	0	0	0	0/5
	65535	65535	0	0	0	0	0	0	0	0	0	0/5
	0	0	0	0	0	0	0	0	255	255	0	0/5
	65535	65535	0	0	0	0	0	0	255	255	0	0/5
	0	0	0	0	0	0	0	0	0	0	0	7/7 (P/T only)
	65535	65535	0	0	0	0	0	0	0	0	0	7/7 (P/T only)
	0	0	0	0	0	0	0	0	255	255	0	7/7 (P/T only)
	65535	65535	0	0	0	0	0	0	255	255	0	7/7 (P/T only)
	45167	27000	255	35	35	255	0	0	85	0	0	0/2
	45167	27000	255	143	143	255	0	0	85	0	11	0/2
	45167	27000	255	53	53	255	0	0	85	0	0	0/2
	45167	27000	255	179	179	255	0	0	85	0	255	0/3
	45167	27000	255	71	71	255	0	0	85	0	0	0/2
	45167	27000	255	161	161	255	0	0	85	0	0	0/2
	45167	27000	255	179	179	255	0	0	85	0	0	0/2
	45167	27000	255	53	53	255	0	0	85	0	0	0/2
	45167	27000	255	143	143	255	0	0	85	0	0	0/2
	45167	27000	255	0	0	255	102	0	215	0	0	0/2
	45167	27000	255	0	0	255	102	216	215	128	0	0/3
	45167	27000	255	0	0	255	102	0	215	255	0	0/2
45167	27000	255	0	0	255	102	255	215	128	0	0/3	

Table 4-5: Diagnostic Tests (Continued)

Test Name	Parameters											
	Pan*	Tilt*	Dim	CWhl	F. Gobo	Iris	R. Gobo	Index	Edge	Zoom	Str	time/total time
ALL2 (cont.)	45167	27000	255	0	0	255	153	107	215	128	0	0/2
	45167	27000	255	0	0	255	153	50	215	0	0	0/2
	45167	27000	255	0	0	255	153	120	215	255	0	0/3
	45167	27000	255	143	0	0	0	0	53	0	0	0/3
	45167	27000	255	0	0	255	0	0	53	0	0	0/2
	45167	27000	255	71	0	0	0	0	53	0	0	0/2
	45167	27000	255	0	0	255	255	0	255	0	0	0/3
	45167	27000	255	0	35	255	255	0	0	0	0	0/3
	45167	27000	255	0	35	255	255	0	255	0	0	0/4
	45167	27000	100	161	255	255	0	0	85	0	0	0/3
	45167	27000	200	216	161	255	0	0	85	0	0	0/3
	45167	27000	100	71	216	255	0	0	85	0	0	0/3
	45167	27000	200	255	71	255	0	0	85	0	0	0/2
PT 1	0	0	0	0	0	0	0	0	0	0	0	0/4.5
	65535	65535	0	0	0	0	0	0	0	0	0	0/4.5
PT 2	0	0	0	0	0	0	0	0	0	0	0	7/7
	65535	65535	0	0	0	0	0	0	0	0	0	7/7
Pan1	0	54957	0	0	0	0	0	0	0	0	0	0/4.5
	65535	54957	0	0	0	0	0	0	0	0	0	0/4.5
Pan2	0	54957	0	0	0	0	0	0	0	0	0	6.5/6.5
	65535	54957	0	0	0	0	0	0	0	0	0	6.5/6.5

Table 4-5: Diagnostic Tests (Continued)

Test Name	Parameters											
	Pan*	Tilt*	Dim	CWhl	F. Gobo	Iris	R. Gobo	Index	Edge	Zoom	Str	time/total time
Pan3	33511	54957	0	0	0	0	0	0	0	0	0	0/2
	22227	54957	0	0	0	0	0	0	0	0	0	0/2
	35511	54957	0	0	0	0	0	0	0	0	0	0/2
	22227	54957	0	0	0	0	0	0	0	0	0	0/2
	44423	54957	0	0	0	0	0	0	0	0	0	0/3
	39401	54957	0	0	0	0	0	0	0	0	0	0/2
	44423	54957	0	0	0	0	0	0	0	0	0	0/2
	34901	54957	0	0	0	0	0	0	0	0	0	0/2
	65535	54957	0	0	0	0	0	0	0	0	0	0/4
0	54957	0	0	0	0	0	0	0	0	0	0/4	
Tilt1	45167	0	0	0	0	0	0	0	0	0	0	0/2.2
	45167	65535	0	0	0	0	0	0	0	0	0	0/2.2
Tilt2	45167	0	0	0	0	0	0	0	0	0	0	4.5/4.5
	45167	65535	0	0	0	0	0	0	0	0	0	4.5/4.5
Tilt3	45167	32767	0	0	0	0	0	0	0	0	0	0/1.2
	45167	11207	0	0	0	0	0	0	0	0	0	0/1
	45167	4487	0	0	0	0	0	0	0	0	0	0/1
	45167	11207	0	0	0	0	0	0	0	0	0	0/1
	45167	4487	0	0	0	0	0	0	0	0	0	0/1
	45167	64555	0	0	0	0	0	0	0	0	0	0/1.5
	45167	54957	0	0	0	0	0	0	0	0	0	0/1.1
	45167	47677	0	0	0	0	0	0	0	0	0	0/1
	45167	54957	0	0	0	0	0	0	0	0	0	0/1
	45167	65535	0	0	0	0	0	0	0	0	0	0/1
Dim1	45167	27000	255	0	0	0	0	0	0	0	0	0/0.5
	45167	27000	0	0	0	0	0	0	0	0	0	0/0.5
Dim2	45167	27000	255	0	0	0	0	0	0	0	0	4.5/4.5
	45167	27000	0	0	0	0	0	0	0	0	0	4.5/4.5

Table 4-5: Diagnostic Tests (Continued)

Test Name	Parameters											
	Pan*	Tilt*	Dim	CWhl	F. Gobo	Iris	R. Gobo	Index	Edge	Zoom	Str	time/total time
Dim3	45167	27000	255	0	0	0	0	0	0	0	0	0/0.5
	45167	27000	128	0	0	0	0	0	0	0	0	0/0.5
	45167	27000	80	0	0	0	0	0	0	0	0	0/0.5
	45167	27000	100	0	0	0	0	0	0	0	0	0/0.5
	45167	27000	40	0	0	0	0	0	0	0	0	0/0.5
	45167	27000	50	0	0	0	0	0	0	0	0	0/0.5
	45167	27000	40	0	0	0	0	0	0	0	0	0/0.5
	45167	27000	60	0	0	0	0	0	0	0	0	0/0.5
	45167	27000	0	0	0	0	0	0	0	0	0	0/0.5
Str	45167	27000	0	0	0	0	0	0	0	0	0	0/1
	45167	27000	0	0	0	0	0	0	0	0	4	0/1
	45167	27000	0	0	0	0	0	0	0	0	0	0/1
	45167	27000	0	0	0	0	0	0	0	0	4	0/1
	45167	27000	0	0	0	0	0	0	0	0	11	0/4
	45167	27000	0	0	0	0	0	0	0	0	0	0/1
	45167	27000	0	0	0	0	0	0	0	0	255	0/3
	45167	27000	0	0	0	0	0	0	0	0	4	0/1
	45167	27000	0	0	0	0	0	0	0	0	255	0/3

Table 4-5: Diagnostic Tests (Continued)

Test Name	Parameters											
	Pan*	Tilt*	Dim	CWhl	F. Gobo	Iris	R. Gobo	Index	Edge	Zoom	Str	time/total time
Cwl1	45167	27000	0	0	0	0	0	0	0	0	0	0/1
	45167	27000	0	17	0	0	0	0	0	0	0	0/1
	45167	27000	0	35	0	0	0	0	0	0	0	0/1
	45167	27000	0	53	0	0	0	0	0	0	0	0/1
	45167	27000	0	71	0	0	0	0	0	0	0	0/1
	45167	27000	0	89	0	0	0	0	0	0	0	0/1
	45167	27000	0	107	0	0	0	0	0	0	0	0/1
	45167	27000	0	125	0	0	0	0	0	0	0	0/1
	45167	27000	0	143	0	0	0	0	0	0	0	0/1
	45167	27000	0	161	0	0	0	0	0	0	0	0/1
	45167	27000	0	179	0	0	0	0	0	0	0	0/1
	45167	27000	0	197	0	0	0	0	0	0	0	0/1
	45167	27000	0	216	0	0	0	0	0	0	0	0/1.65
	45167	27000	0	179	0	0	0	0	0	0	0	0/1
45167	27000	0	255	0	0	0	0	0	0	0	0/1.9	
Cwl2	45167	27000	0	255	0	0	0	0	0	0	0	0/1.9
	45167	27000	0	35	0	0	0	0	0	0	0	0/1
	45167	27000	0	0	0	0	0	0	0	0	0	0/1
Cwl3	45167	27000	0	125	0	0	0	0	0	0	0	0/0.4
	45167	27000	0	71	0	0	0	0	0	0	0	0/0.4
	45167	27000	0	197	0	0	0	0	0	0	0	0/0.4
	45167	27000	0	107	0	0	0	0	0	0	0	0/0.4
	45167	27000	0	89	0	0	0	0	0	0	0	0/0.4
	45167	27000	0	179	0	0	0	0	0	0	0	0/0.4
	45167	27000	0	0	0	0	0	0	0	0	0	0/0.4

Table 4-5: Diagnostic Tests (Continued)

Test Name	Parameters											
	Pan*	Tilt*	Dim	CWhl	F. Gobo	Iris	R. Gobo	Index	Edge	Zoom	Str	time/total time
FG 1	45167	27000	0	0	0	255	0	0	85	0	0	0/1
	45167	27000	0	0	17	255	0	0	85	0	0	0/1
	45167	27000	0	0	35	255	0	0	85	0	0	0/1
	45167	27000	0	0	53	255	0	0	85	0	0	0/1
	45167	27000	0	0	71	255	0	0	85	0	0	0/1
	45167	27000	0	0	89	255	0	0	85	0	0	0/1
	45167	27000	0	0	107	255	0	0	85	0	0	0/1
	45167	27000	0	0	125	255	0	0	85	0	0	0/1
	45167	27000	0	0	143	255	0	0	85	0	0	0/1
	45167	27000	0	0	161	255	0	0	85	0	0	0/1
	45167	27000	0	0	179	255	0	0	85	0	0	0/1
	45167	27000	0	0	197	255	0	0	85	0	0	0/1
	45167	27000	0	0	216	255	0	0	85	0	0	0/1.65
	45167	27000	0	0	179	255	0	0	85	0	0	0/1
	45167	27000	0	0	255	255	0	0	85	0	0	0/1.9
FG 2	45167	27000	0	0	255	255	0	0	85	0	0	0/1.9
	45167	27000	0	0	35	255	0	0	85	0	0	0/1
	45167	27000	0	0	161	255	0	0	85	0	0	0/1
FG 3	45167	27000	0	0	125	255	0	0	85	0	0	0/0.4
	45167	27000	0	0	71	255	0	0	85	0	0	0/0.4
	45167	27000	0	0	197	255	0	0	85	0	0	0/0.4
	45167	27000	0	0	107	255	0	0	85	0	0	0/0.4
	45167	27000	0	0	89	255	0	0	85	0	0	0/0.4
	45167	27000	0	0	179	255	0	0	85	0	0	0/0.4
	45167	27000	0	0	0	255	0	0	85	0	0	0/0.4

Table 4-5: Diagnostic Tests (Continued)

Test Name	Parameters											
	Pan*	Tilt*	Dim	CWhl	F. Gobo	Iris	R. Gobo	Index	Edge	Zoom	Str	time/total time
RG 1	45167	27000	0	0	0	255	0	0	212	0	0	0/1
	45167	27000	0	0	0	255	51	0	212	0	0	0/1
	45167	27000	0	0	0	255	102	0	212	0	0	0/1
	45167	27000	0	0	0	255	153	0	212	0	0	0/1
	45167	27000	0	0	0	255	204	0	212	0	0	0/1
	45167	27000	0	0	0	255	255	0	212	0	0	0/1
RG 2	45167	27000	0	0	0	0	153	0	0	0	0	0/1
	45167	27000	0	0	0	0	153	107	0	0	0	0/1
	45167	27000	0	0	0	0	153	50	0	0	0	0/1
	45167	27000	0	0	0	0	153	204	0	0	0	0/1
	45167	27000	0	0	0	0	153	255	0	0	0	0/3
	45167	27000	0	0	0	0	153	175	0	0	0	0/2
	45167	27000	0	0	0	0	153	216	0	0	0	0/4
	45167	27000	0	0	0	0	153	232	0	0	0	0/1
	45167	27000	0	0	0	0	153	230	0	0	0	0/4
	45167	27000	0	0	0	0	153	234	0	0	0	0/4
Irs1	45167	27000	0	0	0	0	0	0	30	0	0	0/1
	45167	27000	0	0	0	255	0	0	30	0	0	0/1
Irs2	45167	27000	0	0	0	0	0	0	30	0	0	4/4
	45167	27000	0	0	0	255	0	0	30	0	0	4/4
EDG1	45167	27000	0	0	0	255	0	0	0	0	0	0/1
	45167	27000	0	0	0	255	0	0	255	0	0	0/1
EDG2	45167	27000	0	0	0	255	0	0	0	0	0	7/7
	45167	27000	0	0	0	255	0	0	255	0	0	7/7

Table 4-5: Diagnostic Tests (Continued)

Test Name	Parameters											
	Pan*	Tilt*	Dim	CWhl	F. Gobo	Iris	R. Gobo	Index	Edge	Zoom	Str	time/total time
Zm 1	45167	27000	0	0	17	0	0	0	85	0	0	0/1
	45167	27000	0	0	17	0	0	0	85	255	0	0/1
	45167	27000	0	0	17	0	0	0	85	0	0	7/7
	45167	27000	0	0	17	0	0	0	85	255	0	7/7
Zm 3	45167	27000	0	0	17	0	0	0	85	0	0	0/3
	45167	27000	0	0	17	0	0	0	85	128	0	0/2
	45167	27000	0	0	17	0	0	0	85	0	0	0/2
	45167	27000	0	0	17	0	0	0	85	255	0	0/3
	45167	27000	0	0	17	0	0	0	85	128	0	0/2
	45167	27000	0	0	17	0	0	0	85	255	0	0/3

*Pan and Tilt values are 16-bit DMX and will be different from the values in the **Man** control display.

Notes

APPENDIX A.



Troubleshooting and Maintenance

This appendix provides instructions for troubleshooting and performing routine maintenance which may be necessary during the life of the luminaire.

- **Troubleshooting**
- **Routine Maintenance**



WARNING: All maintenance procedures are to be performed with power removed from the luminaire. Never open removable cover while lamp is in operation.

Troubleshooting

Protecting Your Warranty

When performing procedures outlined in the [“Troubleshooting Guide” on page 85](#), observe the following guidelines in order for your luminaire to remain covered by the Vari-Lite Limited Warranty (included in product shipping container).

- Step 1. The luminaire enclosure, yoke, and head covers can be removed to check for loose connectors or obvious signs of wiring, component, subassembly, power supply, or PCB (printed circuit board) failure. Connectors can be removed and reinstalled to check for bent pins or loose wire connections.
- Step 2. Disassembly of the luminaire beyond that outlined in (1.) above will void the Vari-Lite Limited Warranty. Swapping of parts between luminaires for troubleshooting purposes will void the warranty on each luminaire involved. Ordering repair parts or returning subassemblies for repair will void the warranty on the luminaire.

Troubleshooting Guide

If a problem is suspected, try recalibrating the luminaire to prompt an error message. Refer to [“Error Messages” on page 56](#) for more information. The chart below provides possible causes and remedies for each message.



CAUTION: Some troubleshooting is included for reference only. Performing remedies marked by gray areas will void product warranty. Refer to [“Protecting Your Warranty” on page 84](#).

Table A-1: Troubleshooting Guide

Error Display	Description	Possible Cause and Remedy
B1M1 Whl2 NoSn	Aux Board 1, Motor 1, Wheel 2, Sensor Not Found	Wheel 2 power not connected, motor not moving - Connect wheel 2 motor power at motor Wheel 2 sensor not connected - Connect wheel 2 sensor Wheel 2 movement restricted or impeded - Remove obstruction
		Wheel 2 sensor is faulty - Replace wheel 2 sensor assembly Aux Board 1 is faulty Replace aux board
B1M1 Whl2 SAct	Aux Board 1, Motor 1, Wheel 2, Sensor Always Active	Wheel 2 power not connected and wheel 2 aligned with sensor - Connect wheel 2 power at motor
		Wheel 2 not installed on motor shaft - Install wheel 2 on motor shaft Wheel 2 not installed at correct height on motor shaft Fully seat wheel 2 as far down the motor shaft as possible

Table A-1: Troubleshooting Guide (Continued)

Error Display	Description	Possible Cause and Remedy
B1M2 Dimm NoSn	Aux Board 1, Motor 2, Dimmer, Sensor Not Found	Dimmer power not connected, motor not moving - Connect dimmer power at motor Dimmer sensor not connected - Connect dimmer sensor Dimmer movement restricted or impeded - Remove obstruction
		Dimmer sensor is faulty - Replace dimmer sensor assembly Aux Board 1 is faulty Replace aux board
B1M2 Dimm SAct	Aux Board 1, Motor 2, Dimmer, Sensor Always Active	Dimmer power not connected and dimmer aligned with sensor - Connect dimmer power at motor
		Dimmer blade not installed on motor shaft Install dimmer blade on motor shaft
B1M3 Wh1 NoSn	Aux Board 1, Motor 3, Wheel 1, Sensor Not Found	Wheel 1 power not connected, motor not moving - Connect wheel 1 power at motor Wheel 1 sensor not connected - Connect wheel 1 sensor Wheel 1 movement restricted or impeded - Remove obstruction
		Wheel 1 sensor is faulty - Replace wheel 1 sensor assembly Aux Board 1 is faulty Replace aux board
B1M3 Wh1 SAct	Aux Board 1, Motor 3, Wheel 1, Sensor Always Active	Wheel 1 power not connected and wheel 1 aligned with sensor - Connect wheel 1 power at motor
		Wheel 1 not installed on motor shaft Install wheel 1 on motor shaft

Table A-1: Troubleshooting Guide (Continued)

Error Display	Description	Possible Cause and Remedy
B2M1 Gobo NoSn	Aux Board 2, Motor 1, Rotating Gobo Wheel, Sensor Not Found	Rotating gobo wheel power not connected, motor not moving - Connect rotating gobo wheel power at motor Rotating gobo wheel sensor not connected - Connect rotating gobo wheel sensor Rotating gobo wheel movement restricted or impeded - Remove obstruction
		Rotating gobo wheel sensor is faulty - Replace rotating gobo wheel sensor assembly Aux Board 2 is faulty Replace aux board
B2M1 Gobo SAct	Aux Board 2, Motor 1, Rotating Gobo Wheel, Sensor Always Active	Rotating gobo wheel power not connected and rotating gobo wheel aligned with sensor - Connect rotating gobo wheel power at motor
B2M2 Indx NoSn	Aux Board 2, Motor 2, Rotating Gobo Index, Sensor Not Found	Rotating gobo index power not connected, motor not moving - Connect rotating gobo index power at motor Rotating gobo index sensor not connected - Connect rotating gobo index sensor Rotating gobo index movement restricted or impeded - Remove obstruction
		Rotating gobo index sensor is faulty - Replace rotating gobo wheel sensor assembly Rotating gobo wheel has error preventing index to calibrate properly - Ensure rotating gobo wheel is functioning properly Aux Board 2 is faulty Replace aux board

Table A-1: Troubleshooting Guide (Continued)

Error Display	Description	Possible Cause and Remedy
B2M2 Indx SAct	Aux Board 2, Motor 2, Rotating Gobo Index, Sensor Always Active	Rotating gobo index power not connected, rotating gobo wheel power not connected and both wheel and index aligned with sensor - Connect rotating gobo wheel and index power at motors
BRD1 NO COMM	Aux Board 1 Communication Failure	Aux input connector (J5) not connected to either aux board - Connect aux input connector (J5) to either aux board Jumper/bridge connector (J1) between aux boards not connected - Install jumper/bridge connector (J1) between aux boards
BRD2 NO COMM	Aux Board 2 Communication Failure	Aux input connector (J5) not connected to either aux board - Connect aux input connector (J5) to either aux board Jumper/bridge connector (J1) between aux boards not connected - Install jumper/bridge connector (J1) between aux boards
LAMP STRK FAIL	Lamp Strike Failure	Lamp failed to strike after repeated attempts - Replace lamp
PAN ENCR FAIL	Pan Encoder Failure	Main board pan/tilt connector (J9) disconnected - Connect main board pan/tilt connector (J9) Pan motor disconnected - Connect pan motor power
		Encoder faulty Replace pan end-of-travel/encoder sensor assembly
PAN NO SENS	Pan Sensor Not Found	EOT flag attached to large pulley is not engaging the EOT sensor - Ensure flag is attached to the large pulley - Ensure that flag passes through the sensor at a depth sufficient to engage the sensor beam Pan belt disconnected, extremely loose or not installed properly - Properly install belt between pan motor and large pulley

Table A-1: Troubleshooting Guide (Continued)

Error Display	Description	Possible Cause and Remedy
PAN SENS ACTV	Pan Sensor Always Active	Main board pan/tilt connector (J9) disconnected - Connect main board pan/tilt connector (J9) End-of-travel sensor connector (J2) disconnected - Connect end-of-travel sensor connector (J2)
SRCH/FOR/ BRD1 BRD2	Searching for Board 1 or 2	Attempting to communicate with Board 1 or Board 2. System will return either OK or an error code.
TILT ENCR FAIL	Tilt Encoder Failure	Main board pan/tilt connector (J9) disconnected - Connect main board pan/tilt connector (J9) Tilt motor disconnected - Connect tilt motor power
		Encoder faulty Replace tilt end-of-travel/encoder sensor assembly
TILT NO SENS	Tilt Sensor Not Found	EOT flag attached to large pulley is not engaging the EOT sensor - Ensure flag is attached to the large pulley - Ensure that flag passes through the sensor at a depth sufficient to engage the sensor beam Tilt belt disconnected, extremely loose or not installed properly - Properly install belt between tilt motor and large pulley
TILT SENS ACTV	Tilt Sensor Always Active	Main board pan/tilt connector (J9) disconnected - Connect main board pan/tilt connector (J9) End-of-travel sensor connector (J2) disconnected - Connect end-of-travel sensor connector (J2)
WAIT	Retrieving Current Status	System displays wait while getting status.

Table A-1: Troubleshooting Guide (Continued)

Error Display	Description	Possible Cause and Remedy
WRNG SW PROG	Wrong Software Program	Software installed does not match luminaire type - Download the correct software for the luminaire

Routine Maintenance

Lamp Replacement



WARNING: Remove power from luminaire before performing maintenance.

Parts:

700 Watt Short-Arc Lamp (Vari-Lite part: 71.2528.0700)

Tools:

Screwdriver, slotted
Cotton gloves

To replace lamp:

Step 1. Remove power from luminaire.



WARNING: Lamps will be extremely HOT after operation. Allow lamp to cool before replacing.

Step 2. At backcap, using slotted screwdriver (or fingers) turn captive knob until loose.

Step 3. Slide backcap away from head assembly (it will remain attached by tether and lamp wires).

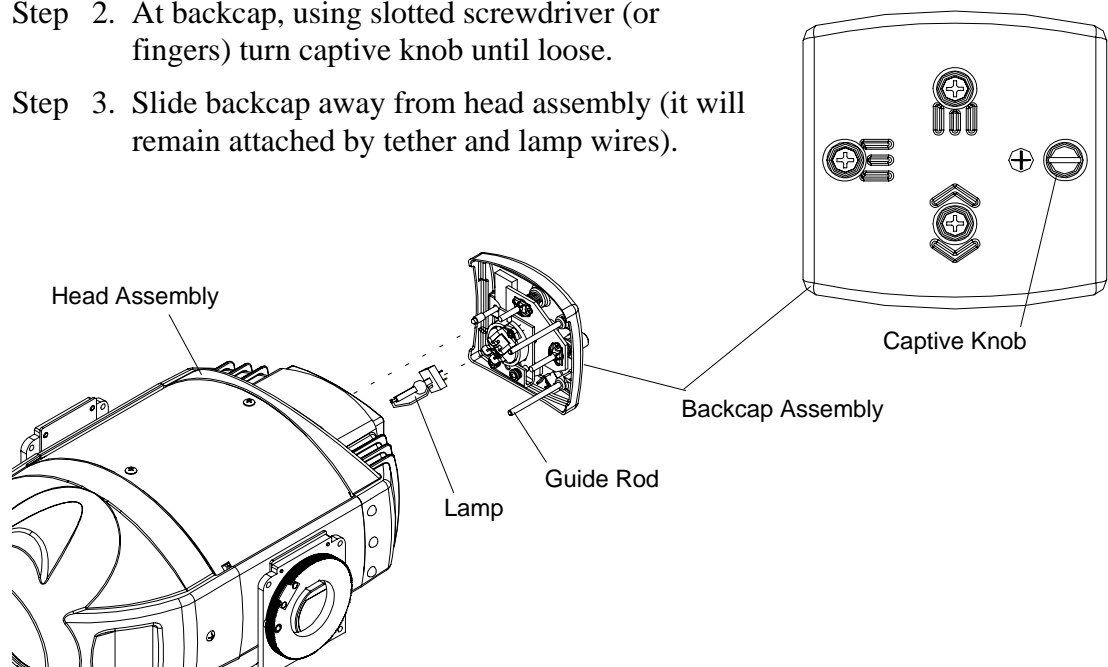



CAUTION: Wear cotton gloves or other covering while servicing lamp. Touching lamp glass with bare fingers will leave oil and may cause the lamp to explode or reduce lamp life. If required, use alcohol and cotton cloth to thoroughly clean glass portion of lamp.

- Step 4. Remove lamp by pulling straight out of socket.
- Step 5. Install new lamp by pressing into socket. Ensure lamp is fully seated in socket and parallel to guide rods. (Lamp can be damaged when inserted through reflector if not parallel to guide rods.)
- Step 6. Align guide rods in guide holes and slide backcap into head assembly. Retighten captive knob.
- Step 7. If required, reset lamp hour and strike counters as follows. (Refer to [“Menu System” chapter on page 51](#) for more information.)
- a. Power up luminaire.
 - b. At Menu Display, press [Menu].
 - c. Press [Up] / [Down] arrows until **CFG** (Configuration) appears. Press [Enter].
 - d. Press [Up] / [Down] arrows until **LAMP** appears. Press [Enter].
 - e. Press [Up] / [Down] arrows to access **RHrs**. Press [Enter] to reset lamp hour and strike counters.
- Step 8. Align lamp. Refer to [“Align Lamp for Flat Field” on page 21](#).

Color Filter Replacement



WARNING: Remove power from luminaire before performing maintenance.

Tools:

Screwdriver, Phillips #2
Cotton gloves

To remove and replace a color filter:

- Step 1. Remove power from luminaire.
- Step 2. At removable cover, using #2 Phillips screwdriver, turn two captive screws one-quarter turn and remove cover. (It will remain attached by tether and lamp wires.)

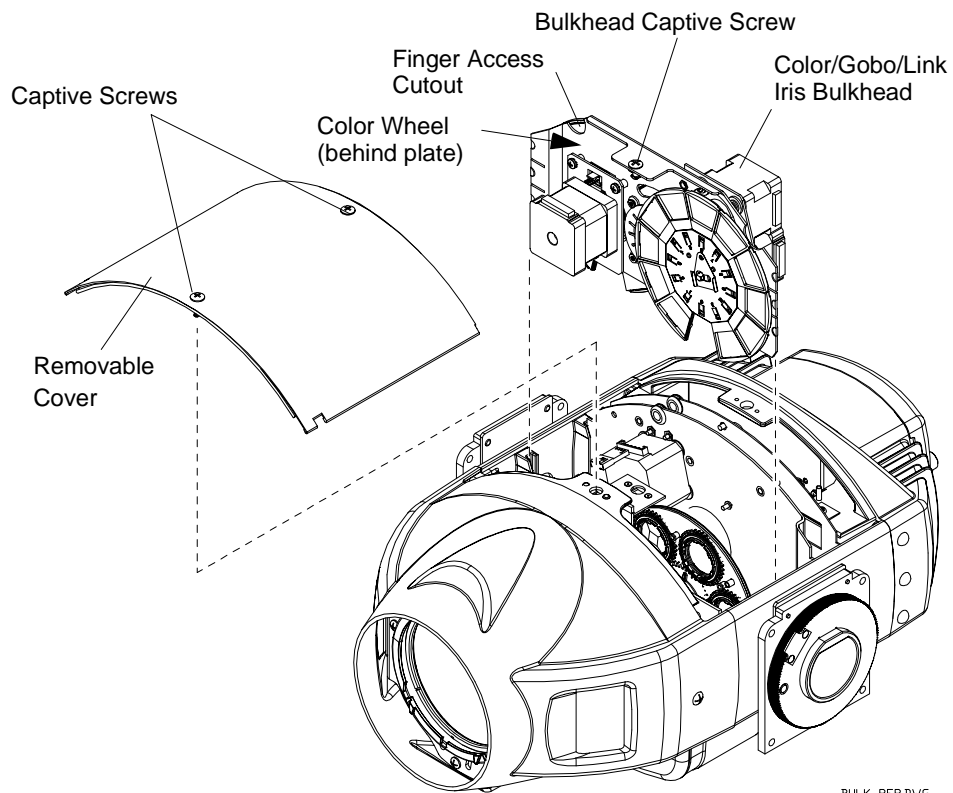



CAUTION: Do not touch color filters with bare fingers. Wear cotton gloves or other covering while replacing. Clean with glass cleaner and soft cloth if required.

Note: In some cases it is easier to slide bulkhead partially out of head assembly to access color filters. To do this, use #2 Phillips screwdriver to turn captive screw one-quarter turn and slide bulkhead upward. Disconnect motor connections as necessary.

Step 3. Rotate wheel until required color filter is accessible at finger access cutout.

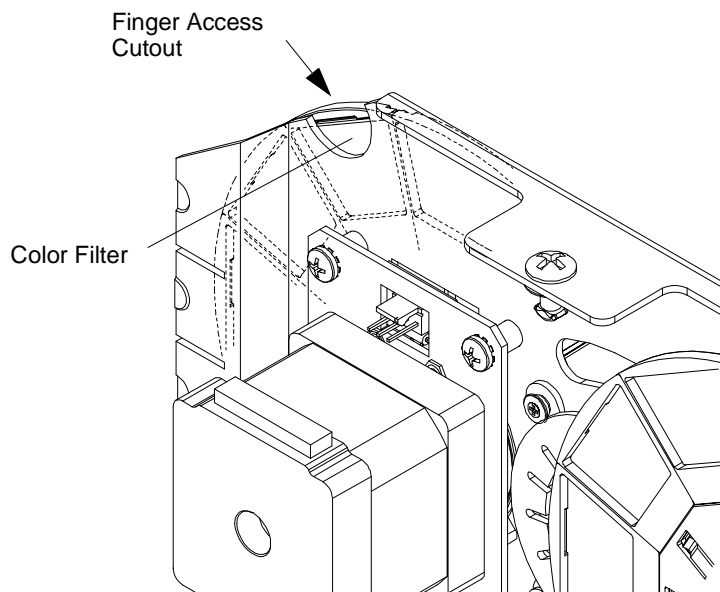

CAUTION: Do not touch color filters with bare fingers. Wear cotton gloves or other covering while replacing. Clean with glass cleaner and soft cloth if touched.

Step 4. Using fingers, pull color filter out of wheel.

Step 5. Noting proper orientation of carrier slot, insert new color filter into position and push fully into place.

Step 6. Re-install bulkhead (if applicable) and re-install removable cover.

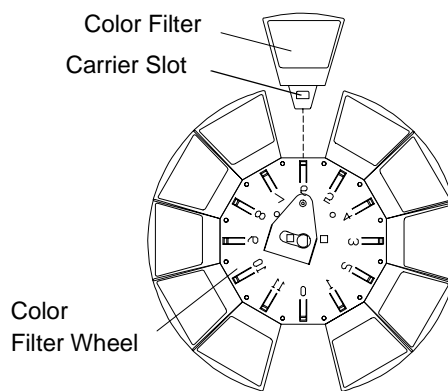

Fixed Gobo Replacement



WARNING: Remove power from luminaire before performing maintenance.

Tools:

Screwdriver, Phillips #2
Cotton gloves

To remove and replace a fixed wheel gobo:

- Step 1. Remove power from luminaire.
- Step 2. At removable cover, using #2 Phillips screwdriver, turn two captive screws one-quarter turn and remove cover. (It will remain attached by tether and lamp wires.)

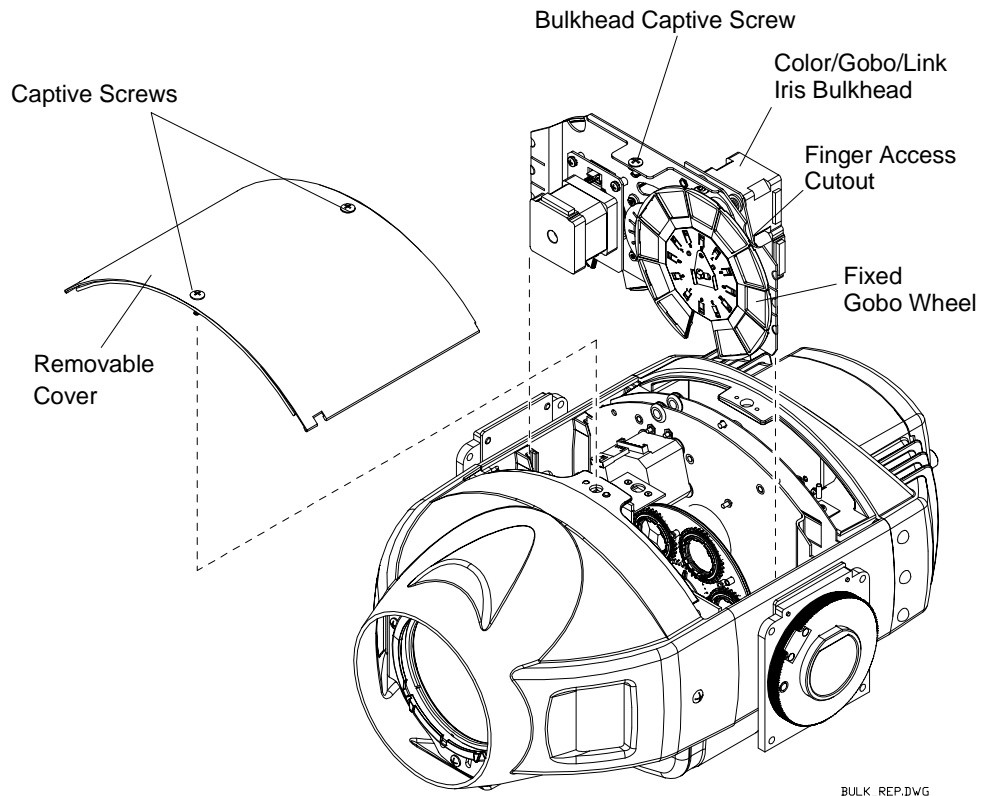



CAUTION: Do not touch gobos with bare fingers. Wear cotton gloves or other covering while replacing. Clean with glass cleaner and soft cloth if required.

Note: In some cases it is easier to slide bulkhead partially out of head assembly to access gobos. To do this, use #2 Phillips screwdriver to turn captive screw one-quarter turn and slide bulkhead upward. Disconnect motor connections as necessary.

Step 3. Rotate wheel until required gobo is accessible at finger access cutout.

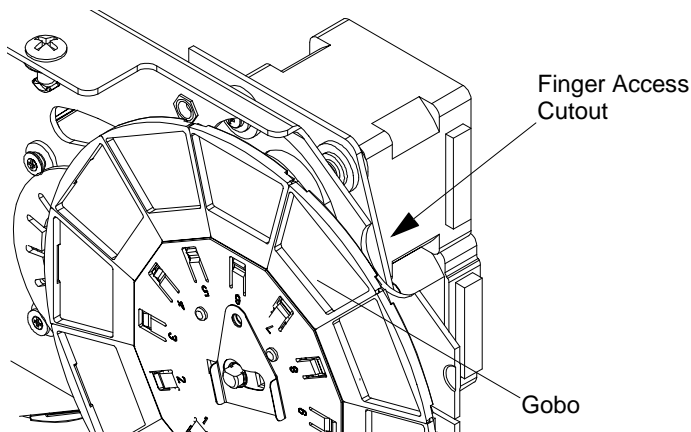

CAUTION: Do not touch gobos with bare fingers. Wear cotton gloves or other covering while replacing. Clean with glass cleaner and soft cloth if required.

Step 4. Using fingers, pull gobo out of wheel.

Step 5. Noting proper orientation of carrier slot and orienting “black” side of gobo toward front lens, insert new gobo into position and push fully into place.

Step 6. Re-install bulkhead (if applicable) and re-install removable cover.

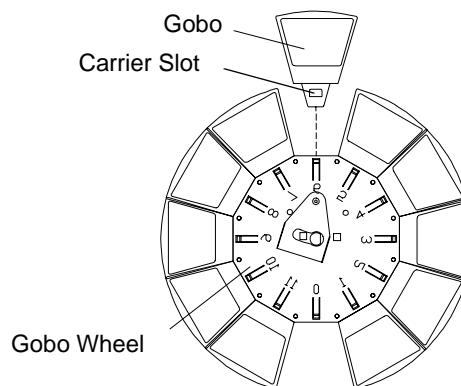

Rotating Gobo Replacement



WARNING: Remove power from luminaire before performing maintenance.

Tools:

Screwdriver, Phillips #2
Hook and Pick tool (or small slotted screwdriver)
Cotton gloves

To remove and replace a rotating gobo:

- Step 1. Remove power from luminaire.
- Step 2. At removable cover, using #2 Phillips screwdriver, turn two captive screws one-quarter turn and remove cover. (It will remain attached by tether and lamp wires.)

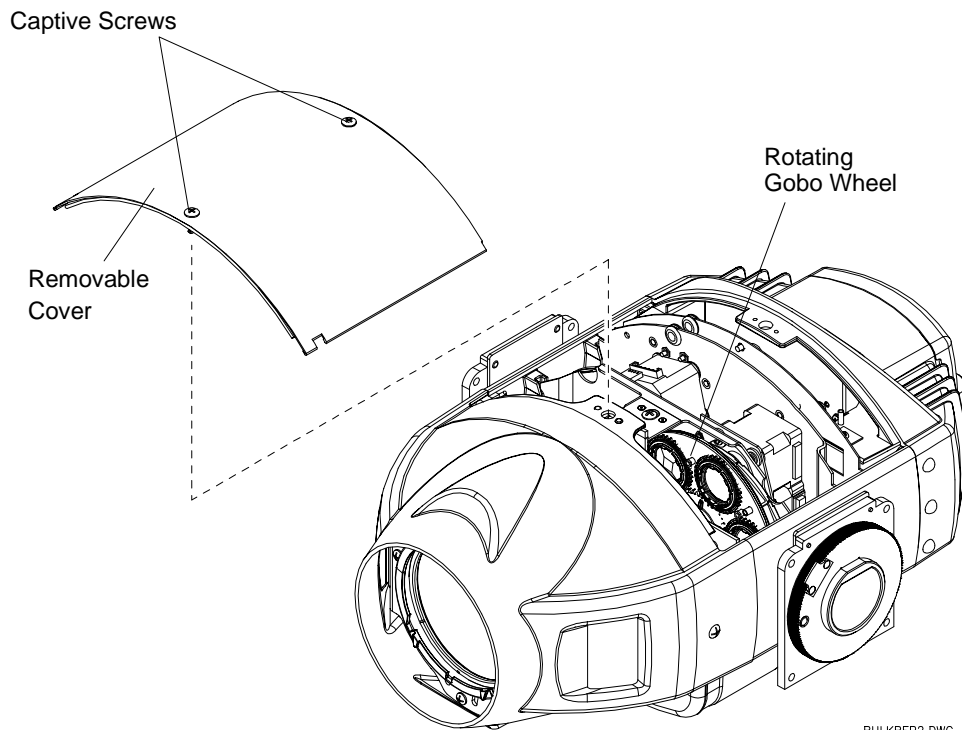

CAUTION: Do not touch gobos with bare fingers. Wear cotton gloves or other covering while replacing. Clean with glass cleaner and soft cloth if required.

- Step 3. At rotating gobo wheel, rotate until required gobo/filter is accessible.

- Step 4. Locate end of coiled spring which is fitted under carrier tab. Using hook and pick tool or small slotted screwdriver, push end of spring from under tab until it is free. Once free, remove entire coiled spring.

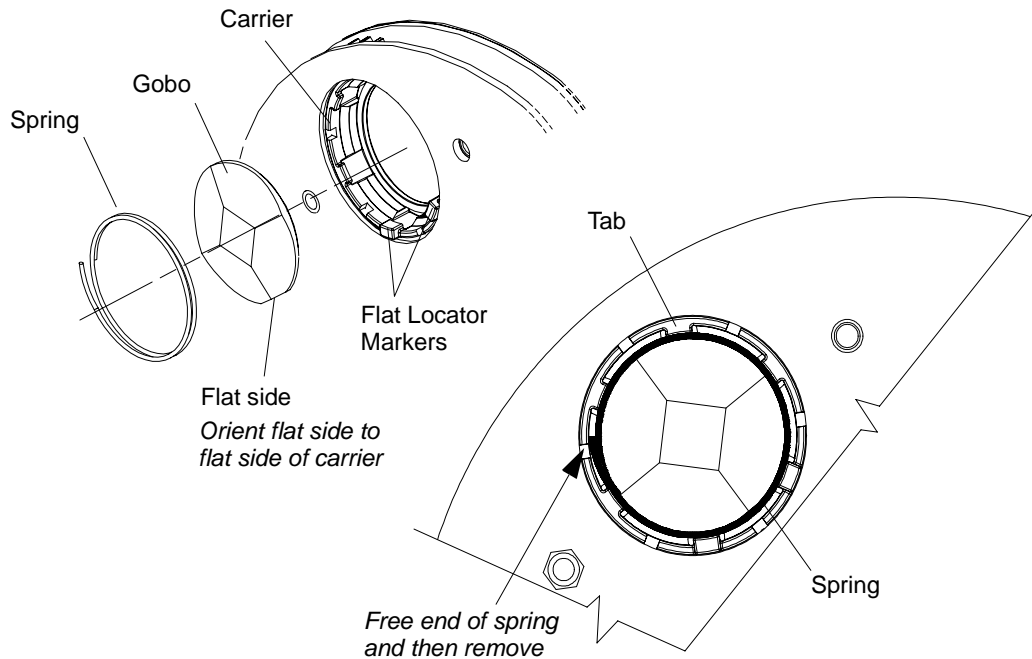

CAUTION: Do not touch gobos with bare fingers. Wear cotton gloves or other covering while replacing. Clean with glass cleaner and soft cloth if required.

- Step 5. Remove gobo.
- Step 6. Aligning flat side correctly and orienting “black” side of gobo toward front lens, install new gobo.
- Step 7. Re-install spring, ensuring it is fully secured under carrier tabs.
- Step 8. Re-install removable cover.

Cleaning Optical Lenses and Filters



WARNING: Remove power from luminaire before performing maintenance.

The front lens, color filters, and gobos may require cleaning after extended use. A common glass cleaner can be used along with a soft, lint-free cloth to clean these components.



CAUTION: Do not continuously rub filters or it may damage or remove the optical coating.

Notes

APPENDIX B.



Technical Specifications

Mechanical

Intensity Control

Full-field dimming designed for both smooth timed fades and strobe effects.

Color/Fixed Gobo Wheels

Two, 12-position wheels, each providing 11 easily loaded positions (and 1 open) for user-selectable color and gobo choices.

Rotating Gobo Wheel

Six-position rotating gobo wheel with five rotatable, indexable gobo positions and one open position.

Zoom Optics

Zoom angle of 2.8 to one. Continuously variable field angle from 19° to 43°. Programmable over a timed range of 2 seconds to 20 minutes.

Edge and Pattern Focus

Variable beam focus to soften edges of gobos or spots.

Beam Size

A mechanical iris provides continuous beam size control for both rapid changes and smooth timed beam angle changes in addition to the zoom optics.

Pan/Tilt

Smooth, time-controlled continuous motion by way of a three-phase stepper motor system. Range: Pan - 540° , Tilt - 270°.

Pan/Tilt Accuracy

0.3° resolution.

Weight

50 lbs (22.7 kg)

Spacing

Refer to illustration on page 18.

Optical

Source

700 Watt Short-Arc Lamp, 5600°K, 80CRI

Reflector

Precision glass reflector with dichroic cold mirror coating.

Flat field design

Operational

Power Requirements

All VL2000 models are powered through standard AC power distribution and require three amps to twelve amps depending on the AC supply voltage and product model.

All VL2000 models operate from 100-240 +/- 10% VAC, 50/60 Hz

Operational Temperature

-20° to 120°F (50°C) at voltages above 100 VAC.

Cooling

Forced air cooling.

Control

Compatible with the VARI*LITE Virtuoso™ control system and a wide variety of DMX consoles.

Mounting Position

The luminaire can be mounted and operated in any orientation.

Photometric

VL2000 Spot Luminaire - 700W Metal Halide

(All data taken with a seasoned light source at 20 hours of life.)

LENS	CANDELA (cd)	BEAM ANGLE (degrees)	BEAM DIAMETER TN*	FIELD ANGLE (degrees)	FIELD DIAMETER TN*
NFOV	297,000	15.0	.263	18.5	.326
MFOV	104,000	25.0	.443	30.5	.545
WFOV	50,000	34.5	.621	42.5	.777

* Multiply throw distance by Tn to determine coverage.

To calculate Illuminance (I) at a specific distance (D): $I = \frac{cd}{D^2}$

Notes

Returning Parts for Service

Obtaining RMA Number and Returning Parts

1. Contact Service Center.
2. Request Return Material Authorization (RMA) number.
3. If returning VL2000 Series Color/Gobo Bulkheads, remove color and gobo wheel hubs. (Do not remove glass color discs from VL2000 wash luminaire subassemblies).
4. Package all parts being shipped. Please take great care in packing your items for return. Wrap all subassemblies and loose parts in bubble wrap or specialty packing material (if required) before shipping.
5. Fill in the form below and pack in box with parts.
6. Return parts and form to the following address:

Vari-Lite, Inc.
RMA# _____
201 Regal Row
Dallas, TX 75247

RMA Number: _____

Customer Name: _____

Fixture Serial Number: _____

Equipment Type: _____

Assembly: _____

Project: _____

Symptoms: _____

Suspected Fault: _____

Comments: _____

For Office Use Only

Technician		Date
Reported		
Repaired		
Logged		
Repairs Completed		

