



**Bissell**<sup>®</sup>

**WE MEAN CLEAN**

# PowerLifter<sup>®</sup> Plus

USER'S GUIDE

MODEL 1620

3 Safety Instructions

4 Product View

5 Assembly

6-12 Operations / Special Tools

12-16 Routine Maintenance

17-18 Troubleshooting

18 Consumer Services

19 Replacement Parts

20 Warranty



*Thanks for Buying a BISSELL PowerLifter Plus Deep Cleaner*

We're glad you purchased a BISSELL PowerLifter Plus Deep Cleaner. Everything we know about floor care went into the design and construction of this complete, high-tech home cleaning system.

Your PowerLifter Plus is well made, and we back it with a limited one-year warranty. We also stand behind it with a knowledgeable, dedicated Consumer Services Department, so, should you ever have a problem, you'll receive fast, considerate assistance.

My great-grandfather invented the floor sweeper in 1876. Today, BISSELL is a global leader in the design, manufacture, and service of high quality homecare products like your PowerLifter Plus.

Thanks again, from all of us at BISSELL.

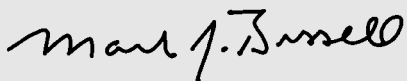

Mark J. Bissell  
President and Chief Executive Officer

# IMPORTANT SAFETY INSTRUCTIONS

**When using an electrical appliance, basic precautions should be observed, including the following:**

Read all instructions before using your POWERLIFTER® PLUS.

**⚠ WARNING:** To reduce the risk of fire, electric shock, or injury:

- Do not immerse.
- Use only on surfaces moistened by cleaning process.
- Always connect to a properly grounded outlet. See Grounding Instructions.
- Unplug from outlet when not in use and before conducting maintenance or troubleshooting.
- Do not leave machine when it is plugged in.
- Do not service machine when it is plugged in.
- Do not use with damaged cord or plug.
- If appliance is not working as it should, has been dropped, damaged, left outdoors, or dropped into water, have it repaired at an authorized Service Center.
- Use Indoors only.
- Do not pull or carry by cord, use cord as a handle, close door on cord, pull cord around sharp corners or edges, run appliance over cord, or expose cord to heated surfaces.
- Do not carry the appliance while in use.
- Do not unplug by pulling on cord. Unplug by grasping the plug, not the cord.
- Do not handle plug or appliance with wet hands.
- Do not put any object into appliance openings, use with blocked opening, or restrict air flow.
- Do not expose hair, loose clothing, fingers or body parts to openings or moving parts.
- Do not pick up hot or burning objects.
- Do not pick up flammable or combustible materials (lighter fluid, gasoline, kerosene, etc.) or use in the presence of explosive liquids or vapor.
- Do not use appliance in an enclosed space filled with vapors given off by oil base paint, paint thinner, some moth proofing substances, flammable dust, or other explosive or toxic vapors.
- Do not pick up toxic material (chlorine bleach, ammonia, drain cleaner, gasoline, etc.).
- Do not modify the 3-prong grounded plug.
- Do not allow to be used as a toy.
- Do not use for any purpose other than described in this User's Guide.
- Do not operate the appliance unless the belt door is securely assembled in the location provided.

- Use only manufacturer's recommended attachments.
- Use only cleaning products formulated by BISSELL for use in this appliance.
- Keep openings free of dust, lint, hair, etc.
- Keep appliance on a level surface.
- Turn off all controls before unplugging.
- Be extra careful when cleaning stairs.
- Close attention is necessary when used by or near children.

**WARNING:** The power cord in this product contains lead, a chemical known to the State of California to cause birth defects or other reproductive harm. **Wash hands after handling.**

## SAVE THESE INSTRUCTIONS.

THIS MODEL IS FOR HOUSEHOLD USE ONLY. Commercial use of this unit voids the manufacturer's warranty.

## GROUNDING INSTRUCTIONS

This appliance must be connected to a grounded wiring system. If it should malfunction or break down, grounding provides a safe path of least resistance for electrical current, reducing the risk of electrical shock. The cord for this appliance has an equipment-grounding conductor and a grounding plug. It must only be plugged into an outlet that is properly installed and grounded in accordance with all local codes and ordinances.

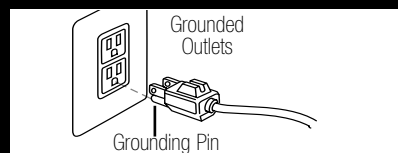

**⚠ WARNING:** Improper connection of the equipment-grounding conductor can result in a risk of electrical shock. Check with a qualified electrician or service person if you aren't sure if the outlet is properly grounded. **DO NOT MODIFY THE PLUG.** If it will not fit the outlet, have a proper outlet installed by a qualified electrician. This appliance is designed for use on a nominal 120-volt circuit, and has a grounding attachment plug that looks like the plug in the drawing above. Make certain that the appliance is connected to an outlet having the same configuration as the plug. No plug adapter should be used

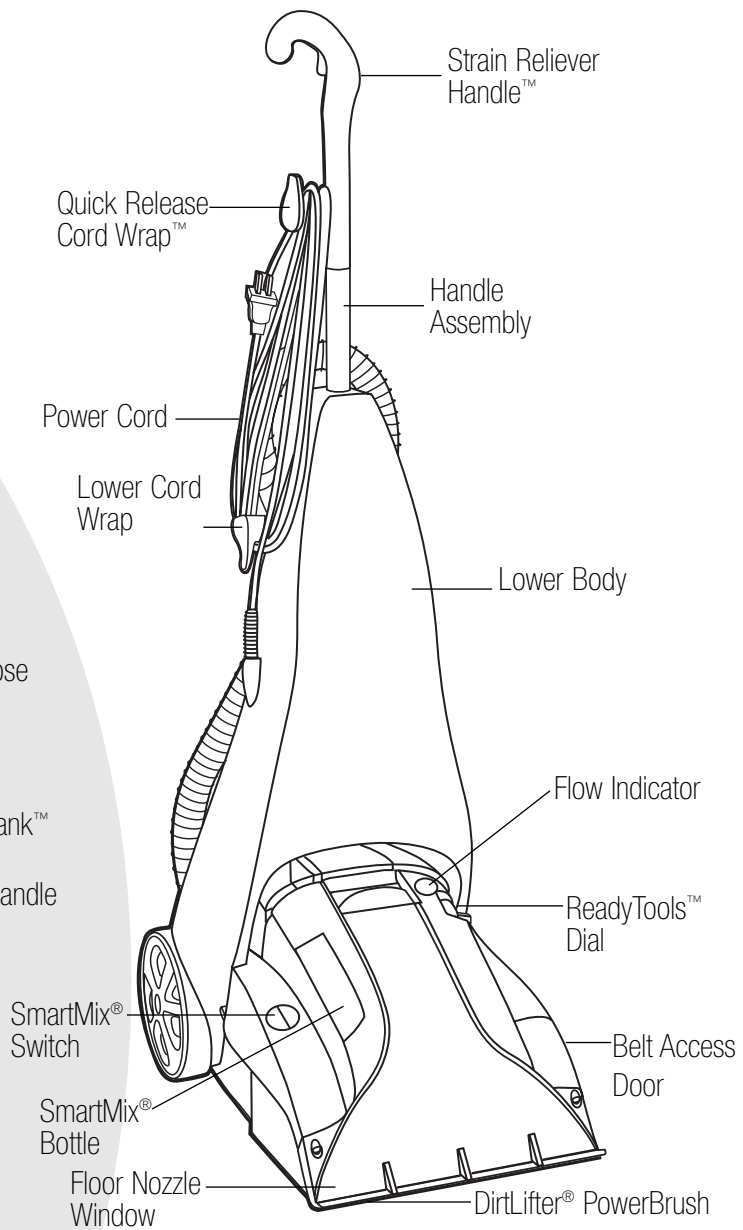
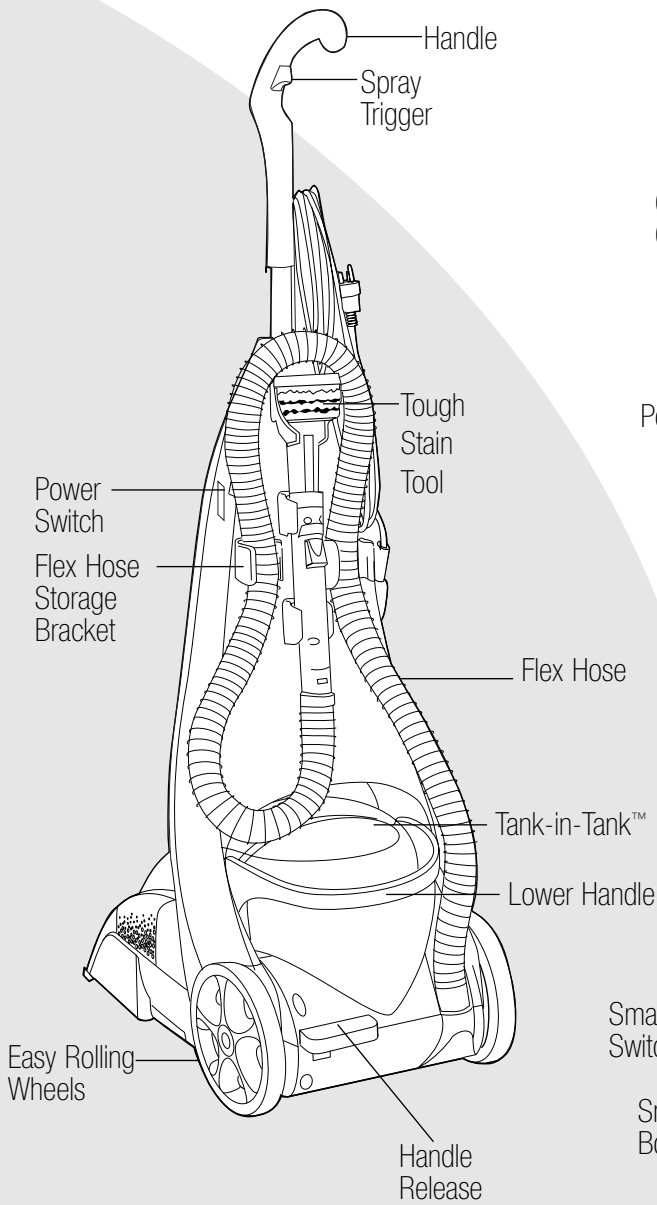

## ACCESSORIES



Tough Stain Tool



16 oz. Fiber  
Cleansing Starter



### WARNING:

To reduce the risk of fire, use only BISSELL Deep Cleaning Formulas in your PowerLifter Plus. Use of cleaning formulas that contain lemon or pine oil may damage this appliance and void warranty. Chemical spot cleaners or solvent-based soil removers should not be used. These products may react with the plastic materials used in your PowerLifter Plus causing cracking or pitting.

## How to Use This Guide

This User's Guide is designed to help you get maximum satisfaction from your PowerLifter Plus Deep Cleaner. Enclosed you'll find assembly instructions for cleaning tasks, safety precautions, cleaning tips, maintenance and troubleshooting information. Please read this Guide thoroughly before assembling and using your cleaner. Pay particular attention to the assembly diagram, assembly instructions, and part names. Locate and organize all parts before assembly. Familiarize yourself with all parts and features and how they operate. Following the Guide will enhance your ability to get top performance from your cleaner for many years.

If you have any questions, or comments please call BISSELL Consumer Services at 1-800-237-7691.

## How To Assemble Your PowerLifter Plus

Your PowerLifter Plus assembles in two quick steps. The only tool you will need to assemble your cleaner is a Phillips head  screwdriver.

Your PowerLifter Plus is packaged as two primary components: the Lower Body and the Handle Assembly. To assemble:

- 1.** Slide the Handle Assembly (with attached Quick Release Cord Wrap™) down into the Lower Body until it will go no further.
- 2.** Secure the handle by placing one (1) Phillips head  screw (supplied) through the screw opening in the Lower Body and into the rear of the Handle Assembly. Tighten with screwdriver until secure.

Assembly is now complete.

## What Comes With Your PowerLifter Plus



Tough Stain Tool



16 oz. Fiber Cleansing Formula™ with Scotchgard protection

Always use BISSELL Deep Cleaning Formulas. Non-BISSELL cleaning solutions may harm your cleaner and void the warranty.

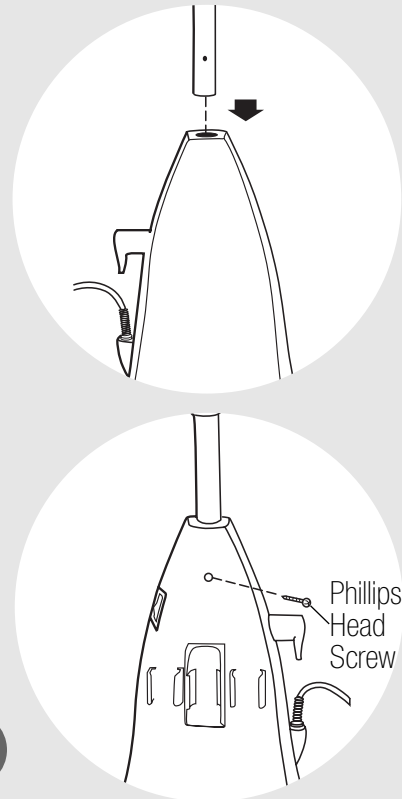

## The Basics: How Your PowerLifter Plus Works

### Power

The Power Switch controls power to the machine.

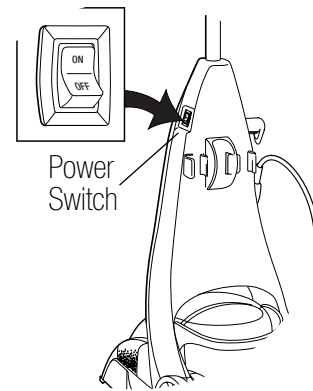

### DirtLifter® Powerbrush

The powered brush roll at the Floor Nozzle is designed to enhance cleaning performance. The bristle pattern lifts out the deep down dirt while gently grooming carpet fibers. The floating suspension self-adjusts to all carpet heights and protects your carpet while in use. When the machine handle is in the fully upright position, the CarpetSaver™ feature automatically raises the brush off the carpet.

### SmartMix®

Provides custom control for each cleaning job.

1. Lift the SmartMix concentrate bottle up and out of the machine base.
2. Turn the bottle over so the valve cap is in an upward position. Unscrew the cap and fill the bottle to the mark with BISSELL Deep Cleaning Formula.
3. Replace the cap until snug.
4. Replace SmartMix Bottle.
5. Choose the SmartMix setting that fits the cleaning job.

**WATER ONLY** – Provides gentle cleaning or a final rinse after cleaning.

**NORMAL** – Automatically provides the best mix of water and concentrate for most cleaning jobs.

**HIGH TRAFFIC** – Automatically mixes the right amount of water and concentrate to dissolve tough grime and heavy soil.

**NOTE: Residual cleaning materials left in carpet from other products may cause excessive foaming when picked up. If foam is overflowing tank, move SmartMix Dial to "WATER ONLY" position until the condition stops.**

**NOTE: Both the SmartMix Bottle and the clean water tank must have liquid in them for the machine to spray. If one is empty, the machine will temporarily lose its prime and not apply either cleaning solution or water.**

**Important: If you are using the WATER ONLY setting, be sure to fill the SmartMix Bottle with water also!**

### Tip:

Deep cleaning carpeting and upholstery regularly can reduce dust and allergens in your home.



### WARNING:

To reduce the risk of fire, electric shock or injury unplug from outlet before servicing.

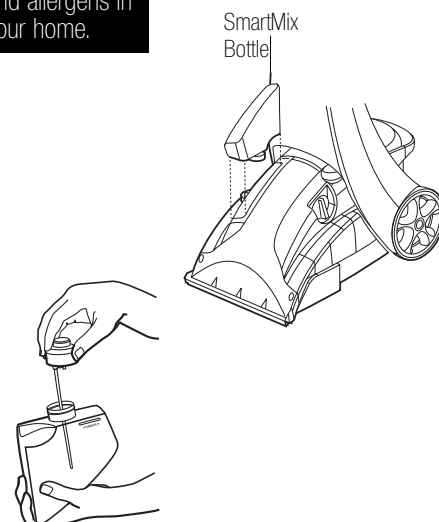

When filling bottle, set dial to:

**SmartMix®**

Dial to:

- HIGH TRAFFIC
- NORMAL
- WATER ONLY

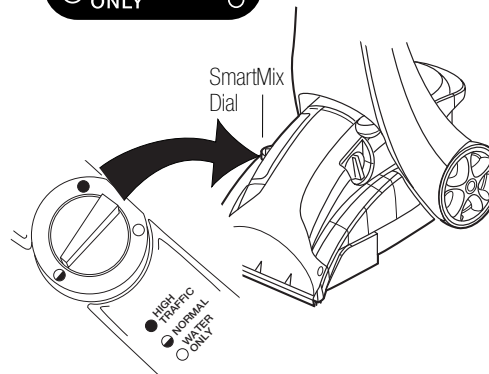

## To Fill The Tank-in-Tank

This easy-to-use system is designed with a bladder inside the tank to hold clean water. As you clean, the bladder will empty. Dirty water collects in the tank outside the bladder.

- 1.** Depress the Handle Release pedal to tilt back the handle.
- 2.** Lift the Tank-in-Tank handle. The handle locks the lid in place. To fill with water, carry the Tank-in-Tank by the handle to the sink.
- 3.** Set the Tank down and rotate the handle forward to unlatch the Lid. Lift off and set the Lid aside.
- 4.** Fill the bladder with hot tap water up to the bottom of the neck. **Do not boil or microwave water as it can destroy the bladder.**

**NOTE: Fill slowly to reduce sudsing.**

- 5.** Replace the Tank Lid, matching the Lid and Tank edges. **Handle must be in the forward position to reinstall.** Rotate the handle to carrying position to relatch the lid. Replace Tank in machine base, seating firmly in place. Rotate handle back and push down to latched position.

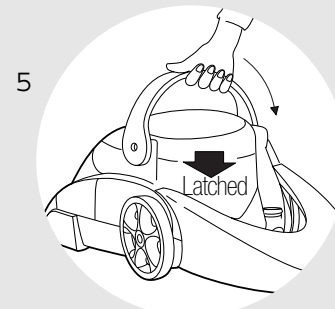
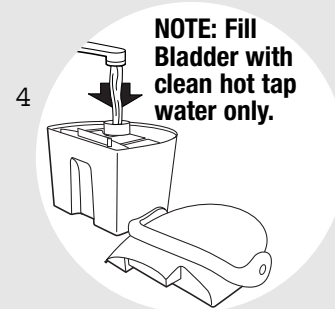
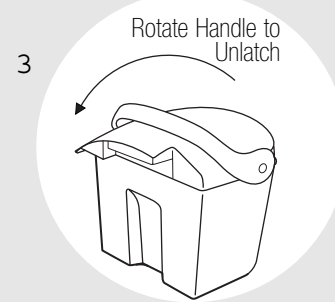
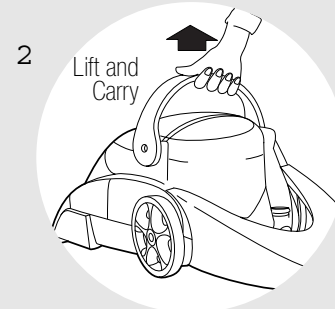
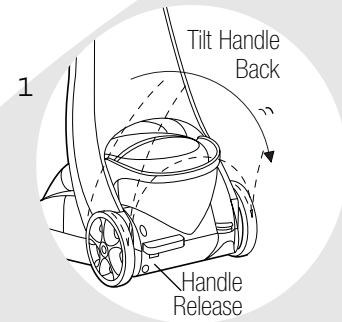

## When It's Time To Empty The Tank-in-Tank

**NOTE: Remove the Tank-in-Tank, following steps 1 and 2 on page 7.**

- 1.** Carry the Tank-in-Tank, like a bucket, to the sink to dispose of the dirty water. Remove Tank Lid. Pour out dirty water.
- 2.** After each use, remove and rinse the red Lint Screen located on the Tank Lid.
  - A.** Remove Tank Lid.
  - B.** Remove Lint Screen and rinse under faucet. Remove any debris caught in Lint Screen.
  - C.** Reinsert Lint Screen on Tank Lid. The screen will click into place.
  - D.** Replace Tank Lid.
- 3.** Refill with clean hot tap water—follow steps 4-5 on page 7.
- 4.** When the cleaning job is complete, rinse out the Tank-in-Tank by running clean water between the bladder and the tank.
- 5.** Return the Tank-in-Tank to the machine, following step 5 on page 7.
- 6.** Refer to the Maintenance/Storage section on pages 12-13 for final cleanup.

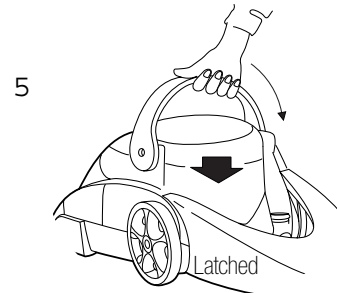
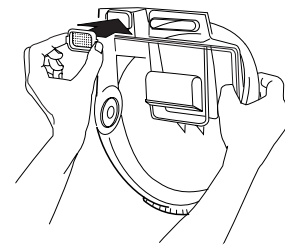
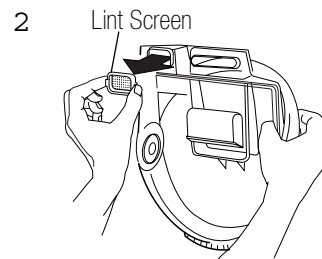
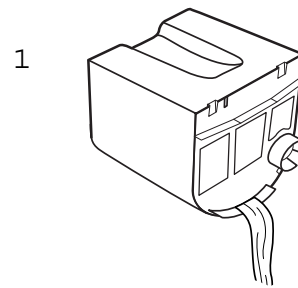

## The Flow Indicator

The Flow Indicator is located on the machine base. It spins when the trigger is pressed to indicate the machine is applying cleaning solution to the floor. It will stop spinning to indicate the SmartMix Bottle or bladder needs to be refilled, or when the trigger is released. The Flow Indicator does not spin when the ReadyTools Dial is set to TOOLS/PRETREAT.

### Tip:

A special red float device in the tank lid will cause the cleaner to stop removing solution from the carpet. The motor sound will rise in pitch to let you know the dirty water tank is full.

## ReadyTools™ Dial

The ReadyTools Dial regulates suction for floor or upholstery cleaning with the turn of a dial. For carpet/floor cleaning make sure the dial is set to FLOOR CLEANING. For upholstery or fabric cleaning, attach Tough Stain Tool to the the Flex Hose, switch to TOOLS/PRETREAT and the PowerLifter Plus is ready to clean upholstery, fabrics and more.

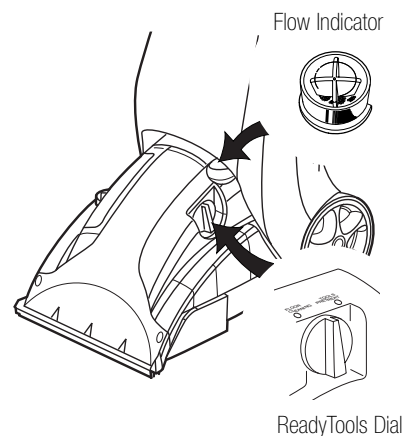



## How To Clean Carpets

1. Plan activities to give carpet time to dry.
2. Remove furniture from the room (chairs, lamps, coffee tables, etc.).
3. Vacuum thoroughly to pick up loose debris and pet hair before using the PowerLifter Plus.
4. Plan your cleaning route to leave an exit path. It is best to begin cleaning in the corner furthest from your exit.

**NOTE: You may notice hair and debris deposits on carpet that were loosened by brushing action, especially with newer carpets that have never been deep cleaned before. This debris should be picked up by hand and thrown away. Debris in the Brush Belt area should be cleaned out to keep Belts running free.**

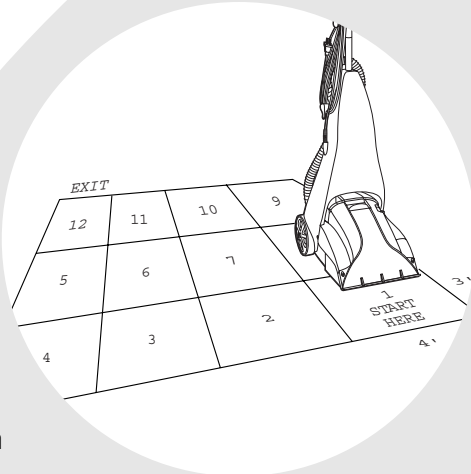

### Machine Preparation

1. Use a BISSELL Deep Cleaning Formula in the SmartMix Bottle. When cleaning carpets, stairs or upholstery, use clean water in the SmartMix Bottle for gentle cleansing or rinsing.
2. Choose the SmartMix setting to match the cleaning job.
3. Set the ReadyTools Dial to either TOOLS/PRETREAT or FLOOR CLEANING.

### PreTreating

Pretreating is recommended to improve cleaning effectiveness for heavily soiled carpet in high traffic areas such as entryways and hallways.

1. Set the SmartMix Dial to HIGH TRAFFIC.
2. Set the ReadyTools Dial to PRETREAT.
3. Plug into a proper outlet and turn ON the power switch.
4. While pressing the trigger, slowly make several passes over the area to be cleaned. **CAUTION: Do not overwet.**
5. Turn the machine Power Switch OFF and let the BISSELL Deep Cleaning Formula dissolve the tough soil for one to two minutes before continuing.

### ATTENTION BERBER CARPET OWNERS:

Some Berber Carpets have a tendency to fuzz with wear. Repeated strokes in the same area with an ordinary vacuum or deep cleaner may aggravate this condition.

#### Tip:

Try pretreating stairs or entry ways with BISSELL Tough Stain PreCleaner. Then deep clean with the SmartMix® dial set on High Traffic.



## Normal Cleaning

**1.** Plug the PowerLifter Plus into a proper outlet and turn the Power Switch ON. Set the ReadyTools Dial to FLOORCLEANING

**2.** While pressing the Spray Trigger, make one slow forward and back wet pass. Let the BISSELL Deep Cleaning Formula and DirtLifter PowerBrush do the work for you.

**Caution: Do not overwet.**

**NOTE: Do not run over loose objects or edges of area rugs. Stalling brush may result in premature belt failure.**

**3.** Release the Spray Trigger and make one slow forward and back pass over the same area to remove any residual dirty water.

**4.** Repeat cleaning passes without pressing the Spray Trigger until water is no longer being suctioned up through the FLOOR NOZZLE window.

**NOTE: Both the SmartMix Bottle and Tank-in-Tank must have liquid in them in order for the machine to spray. If one tank is empty the machine will not apply either cleaning solution or water.**

**5.** After cleaning, you may want to turn the SmartMix Dial to WATER ONLY to give your carpeting a final rinse. This will ensure thorough removal of embedded dirt loosened by the Deep Cleaning Formula. BISSELL Deep Cleaning Formulas contain a Scotchgard agent that helps your carpets repel dirt and keeps them looking good longer.

**6.** When cleaning job is complete, refer to the Maintenance/Storage section on pages 12-13.

### Tip:

Thorough vacuuming before deep cleaning will prevent early clogging of the lint trap.



## How To Clean Upholstery and Small Areas

### Important - Check Upholstery Tags

Check manufacturer's tag before cleaning. A "W" or "WS" on the tag means you can use your PowerLifter Plus. If the tag is coded with an "X" or "S" (with a diagonal strike through), or says "Dry Clean Only," do not proceed. Do not use your PowerLifter Plus on velvet or silk. If manufacturer's tag is missing or not coded, check with your furniture dealer.

Check for colorfastness in an inconspicuous place.

If possible, check upholstery stuffing. Colored stuffing may bleed through fabric when wet.

Plan activities to give upholstery time to dry.

Vacuum thoroughly to pick up loose debris and pet hair. Use a vacuum with a brush attachment and a crevice tool to clean in fabric folds and tufts.

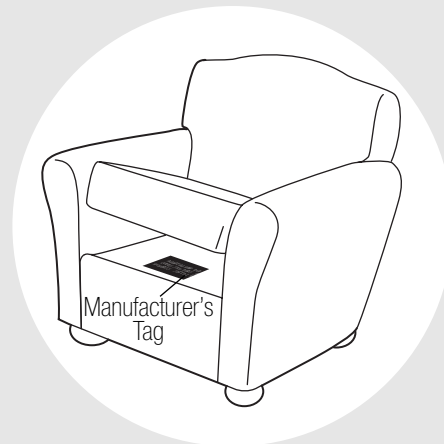

### Machine Preparation

- 1.** Set up the machine following instructions in The Basics section, pages 6-8.
- 2.** Set the ReadyTools Dial to TOOLS/PRETREAT.
- 3.** Set SmartMix Dial to NORMAL.

## Cleaning Technique

1. Connect the Tough Stain Tool to the Flex Hose.
2. Plug into a proper outlet and turn the Power Switch ON.
3. While pressing the trigger, slowly move the spraying tool back and forth over the soiled surface. Release the trigger to suction soiled water.
4. Continue to clean soiled area, working in small sections, until no more dirt can be removed.  
**Caution: Do not overwet.**
5. When the cleaning job is complete, refer to the Maintenance/Storage section below.

## Maintenance/Storage

1. Turn Power Switch OFF. Make sure to switch SmartMix Dial to WATER ONLY.
2. Unplug Power Cord from outlet and wrap cord around the Quick Release Cord Wrap.
3. Remove and rinse tools in clean water. Dry and replace.
4. Coil Flex Hose through Flex Hose Storage Brackets.
5. Remove Tank-in-Tank. Dispose of dirty water. See The Basics section, page 8.

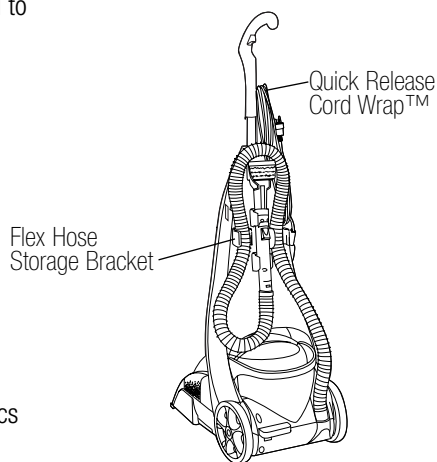

**⚠ CAUTION:**  
PowerLifter Plus uses water and must not be stored where there is a danger of freezing. Freezing will damage internal components and void the warranty.

## Maintenance/Storage Continued

6. Rinse out Tank-in-Tank and reseal the tank onto the machine.
7. Clean out the Flow Indicator Filter each time it is used to ensure best cleaning performance. Unscrew the Flow Indicator cap, lift out the red Rotor and white Filter. Rinse all three parts in tap water. Replace the Filter and Rotor. Replace the Flow Indicator Cap; turn until snug, do not over-tighten.
8. Wipe all exterior surfaces with a soft cloth.
9. Store cleaner in a protected, dry area.
10. When carpet is dry, vacuum again to remove hair and fuzz that the PowerLifter Plus may have loosened.

When filling bottle  
storing unit, set  
**SmartMix®**  
Dial to:  
○ WATER  
○ ONLY

### Tip:

SmartMix Bottle may be stored with concentrate ready for your next cleaning job. Make sure dial is turned to the WATER ONLY Setting when storing

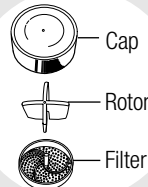

## Pump & Brush Belts Replacement

### To Remove Broken Pump & Brush Belts

**NOTE: Turn off machine and unplug from wall outlet.**

1. Step on Handle Release pedal and recline Handle on floor (see illustration).
2. Remove the Tank-in-Tank. Set aside (see illustration).
3. Remove the Belt Access Door located near the ReadyTools Dial. Insert a flathead screwdriver into the slot nearest the handle to gently pry off the door (see illustration).

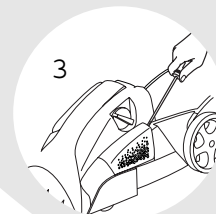
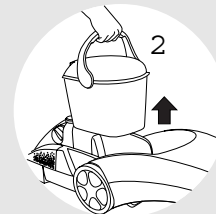
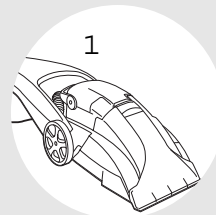

## To Remove Broken Pump & Brush Belts-Continued

- 4.** Turn the machine onto its side so the belt access area is facing upward (see illustration).
- 5.** On the bottom of the machine, near the belt access area, is a red Retainer Plate that holds the black brush arm and brush in place. Using a Phillips head screwdriver remove the screw that holds the red Retainer Plate in place. Set red Retainer Plate and Phillips head screw aside (see illustration).
- 6.** Remove the black brush arm that holds the brush in place. Set the black brush arm aside (see illustration).
- 7.** Remove the "toothed" Brush Belt from the Brush, then from the red Pump Pulley. Set the "toothed" Brush Belt and Brush aside.
- 8.** Locate and remove the broken Pump Belt.

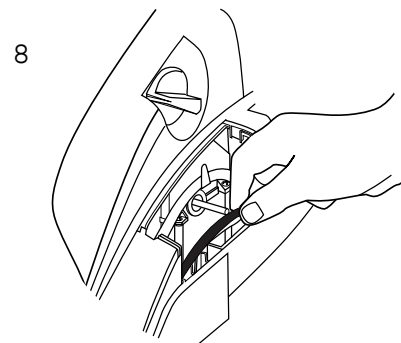
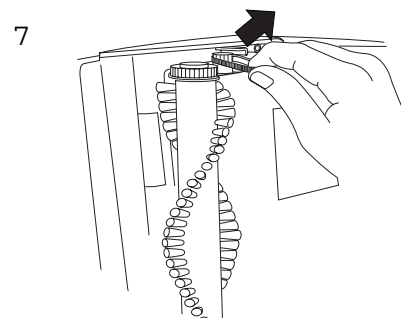
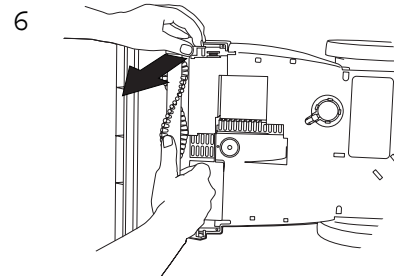
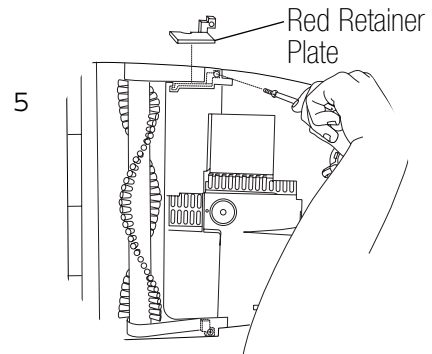
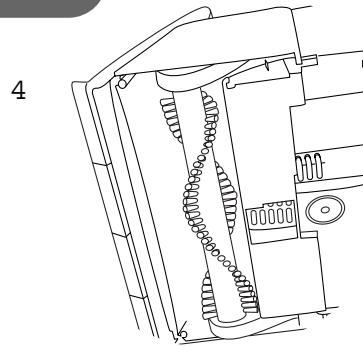

## To Install The Replacement Pump & Brush Belts

- 1.** With the unit still on its side, loop one end of the replacement Pump Belt around the red Pump Pulley and the other end around the silver motor shaft (see illustration). Do not twist the replacement Pump Belt.
- 2.** Re-install the “toothed” Brush Belt first onto the red Pump Pulley and then onto the “toothed” end of the Brush (see illustration).
- 3.** Re-install the Brush into the base of the unit. (see illustration)
- 4.** Place the black brush arm onto the Brush and slide black brush arm into original position (see illustration).

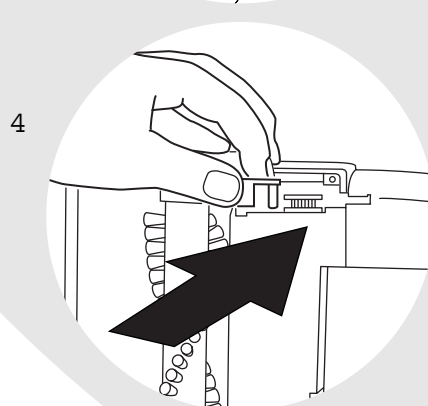
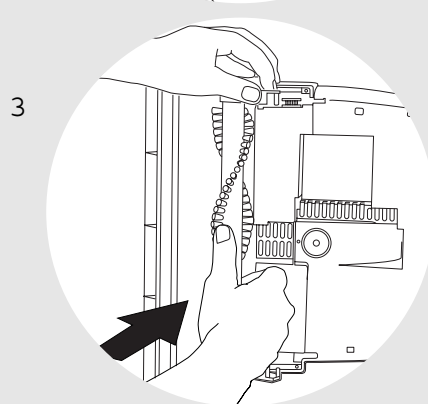
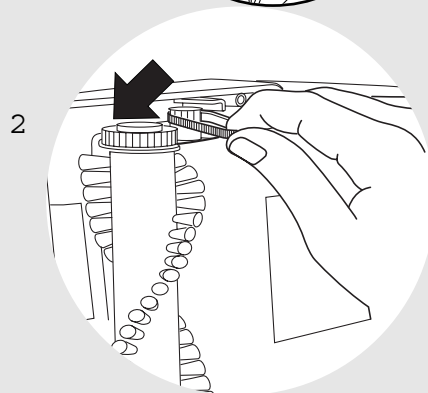
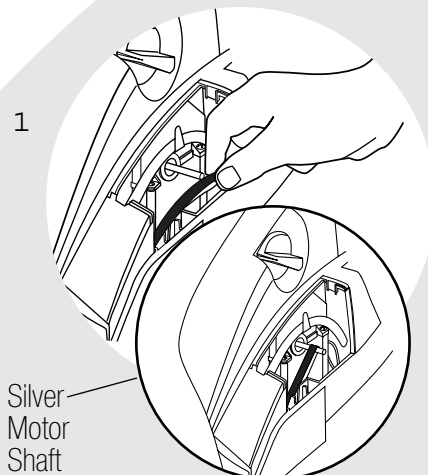

## To Install The Replacement Pump & Brush Belts-Continued

- 5.** Re-install the red Retainer Plate and Phillips head screw (see illustration).
- 6.** Using your finger, gently spin the replacement Pump Belt on the silver motor shaft (see illustration). If assembled correctly, the replacement Pump Belt should rotate freely around the silver motor shaft and drive pulley without obstruction. The Brush should also rotate freely when the silver motor shaft is turned.
- 7.** Turn the machine right side up. Replace the Tank-in-Tank and Belt Access Door (see illustration).

**Assembly is now complete.**

If you have any questions, or if you have any trouble installing your replacement Pump Belt, please call BISSELL Consumer Services at 1-800-237-7691. Or visit the BISSELL website: [www.bissell.com](http://www.bissell.com)

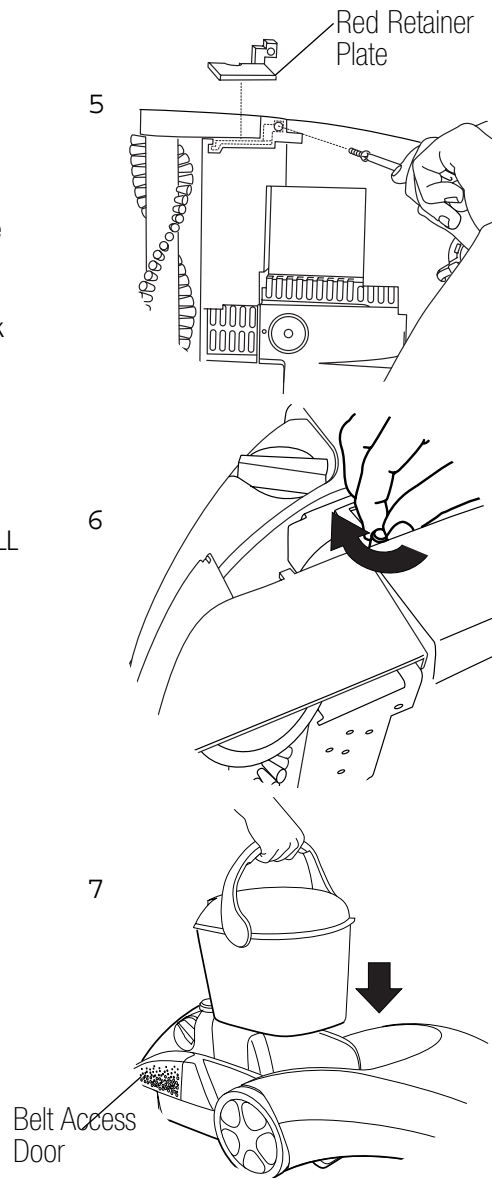



### **⚠️ WARNING:**

To reduce the risk of fire, electric shock, or injury, unplug machine from outlet before servicing.

### **Reduced spray or no spray.**

#### **Possible Causes**

- 1 Bladder may be empty
- 2 SmartMix may be empty
- 3 The lint screen may be clogged
- 4 Tank-in-Tank may not be seated properly
- 5 Pump may have lost prime
- 6 The Pump Belt may be broken

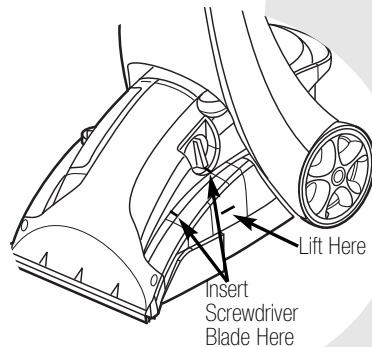

### **DirtLifter PowerBrush does not turn.**

#### **Possible Causes**

- 1 The Brush Belt or Pump Belt may be broken

#### **Remedies**

- 1 Turn power OFF, refill tank with hot tap water.
- 2 Refill bottle with formula.
- 3 Turn power OFF, clean out lint screen, follow step 2 on page 8.
- 4 Turn power OFF; remove and reseal tank.
- 5 Turn power OFF; after 1 minute, turn ON and depress Spray trigger.
- 6 Turn power OFF and unplug machine from outlet. To check if a Pump Belt has broken, you will need a flathead screwdriver. Insert the blade end into the lower slot of the Belt Access Door to release the latch. If necessary, insert the blade end into the upper slot to release the upper latch. Examine for belt breakage. You should be able to see the Pump Belt looped around the motor shaft. If it is broken or missing, please refer to the part numbers and descriptions on page 19 before calling BISSELL Consumer Services. Complete installation instructions will accompany the replacement belt.

#### **Remedies**

- 1 Turn power OFF and unplug machine from outlet. To check if a Brush Belt has broken, you will need a flathead screwdriver. Insert the blade end into the lower slot of the Belt Access Door to release the lower latch. If necessary, insert the blade end into the upper slot to release the upper latch. Examine for belt breakage. If broken, refer to pages 13-16.

## Troubleshooting continued

### ***PowerLifter Plus is not picking up solution.***

#### **Possible Causes**

- 1 ReadyTools Dial may be at the wrong setting for cleaning job
- 2 Nozzle Window may not be properly attached
- 3 Tank-in-Tank lid is not properly installed
- 4 Tank-in-Tank is not properly seated
- 5 Tank-in-Tank has picked up the maximum amount of dirty water
- 6 Poor tool position (Handheld attachments only.)

#### **Remedies**

- 1 Set ReadyTools Dial to either FLOOR CLEANING or TOOLS/PRETREAT.
- 2 Make sure the two tabs on the back of the Floor Nozzle Window are inserted through the mating slots in the main housing. Reinstall if necessary.
- 3 Reinstall lid; refer to The Basics section, step 5 on page 7.
- 4 Tank-in-Tank must be firmly seated to function. Remove and reseal Tank-in-Tank.
- 5 Empty tank and refill; refer to the Basics section, page 8.
- 6 Readjust angle; apply more downward pressure.

***Thank you for selecting a BISSELL product.***

If you should happen to need assistance during assembly or operation, call: 1-800-237-7691

**Please do not return this  
product to the store.**

## BISSELL Consumer Services

For information about repairs or replacement parts, or questions about your warranty, call:

**BISSELL Consumer Services**

**1-800-237-7691**

Monday - Friday 8 a.m. — 10 p.m. ET

Saturday 9 a.m. — 8 p.m. ET

Or write:

BISSELL Homecare, Inc.

PO Box 3606

Grand Rapids MI 49501

ATTN: Consumer Services

Or visit the BISSELL website - [www.bissell.com](http://www.bissell.com)

When contacting BISSELL, have model number of unit available.

Please record your Model Number: \_\_\_\_\_

Please record your Purchase Date: \_\_\_\_\_

**NOTE: Please keep your original sales receipt. It is your warranty.**

## Part Numbers And Descriptions

Item	Part No.	Part Name
1	213-4032	Handle Assembly with Screw
2	215-9155	Tough Stain Tool
3	015-9043	Tank Assembly Complete
4	015-4439	Tank Lid Assembly
5	015-9041	Tank Bottom
6	213-0213	Baffle with Red Float
7	210-4052	Window Gasket
8	215-0628	Replacement Pump Belt (with instructions)
9	015-0621	Replacement Brush Belt (with instructions)
10	213-3501	Lint Screen
11	210-1785	SmartMix® Bottle (Includes Cap)
12	210-1795	SmartMix® Cap Assembly
13	210-1651	Flow Indicator Cap
14	210-6214	Flow Indicator O-ring
15	210-7635	Flow Indicator Rotor
16	210-3510	Flow Indicator Filter
17	014-9865	Floor Nozzle Window
18	0710	48 oz. BISSELL Fiber Cleansing Formula with Scotchgard™
19	0400	22 oz. BISSELL Tough Stain PreCleaner

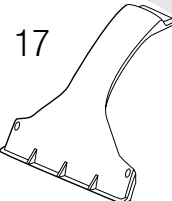
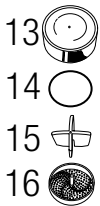
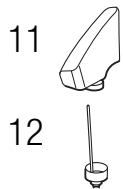
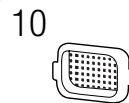
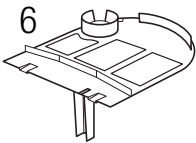
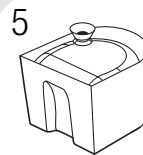
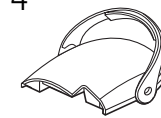
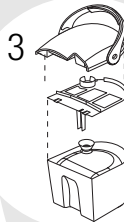
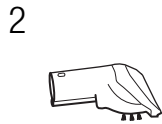
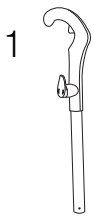

## About Your Warranty

This warranty gives you specific legal rights, and you may also have other rights which may vary from state to state. If you need additional instruction regarding this warranty or have questions regarding what it may cover, please contact BISSELL Consumer Services by E-mail, telephone, or regular mail as described below.

### Limited **One** Year Warranty

Subject to the \*EXCEPTIONS AND EXCLUSIONS identified below, upon receipt of the product, BISSELL Homecare, Inc. will repair or replace (with new or remanufactured components or products), at BISSELL's option, free of charge from the date of purchase by the original purchaser, for one year any defective or malfunctioning part.

See information below on "If your BISSELL product should require service".

This warranty applies to product used for personal, and not commercial or rental service. This warranty does not apply to fans or routine maintenance components such as filters, belts, or brushes. Damage or malfunction caused by negligence, abuse, neglect, unauthorized repair, or any other use not in accordance with the User's Guide is not covered.

### **If your BISSELL product should require service:**

Contact BISSELL Consumer Services to locate a BISSELL Authorized Service Center in your area.

If you need information about repairs or replacement parts, or if you have questions about your warranty, contact **BISSELL Consumer Services**.

#### **Website or E-mail:**

[www.bissell.com](http://www.bissell.com)  
Use the "Customer Service" tab.

#### **Or Call:**

BISSELL Consumer Services  
1-800-237-7691  
Monday - Friday 8 a.m. - 10 p.m. ET  
Saturday 9 a.m. - 8 p.m. ET

#### **Or write:**

BISSELL Homecare, Inc.  
PO Box 3606  
Grand Rapids MI 49501  
ATTN: Consumer Services

BISSELL HOMECARE, INC. IS NOT LIABLE FOR INCIDENTAL OR CONSEQUENTIAL DAMAGES OF ANY NATURE ASSOCIATED WITH THE USE OF THIS PRODUCT. BISSELL'S LIABILITY WILL NOT EXCEED THE PURCHASE PRICE OF THE PRODUCT.

Some states do not allow the exclusion or limitation of incidental or consequential damages, so the above limitation or exclusion may not apply to you.

#### \*EXCEPTIONS AND EXCLUSIONS FROM THE TERMS OF THE **LIMITED** WARRANTY

THIS WARRANTY IS EXCLUSIVE AND IN LIEU OF ANY OTHER WARRANTIES EITHER ORAL OR WRITTEN. ANY IMPLIED WARRANTIES WHICH MAY ARISE BY OPERATION OF LAW, INCLUDING THE IMPLIED WARRANTIES OF MERCHANTABILITY AND FITNESS FOR A PARTICULAR PURPOSE, ARE LIMITED TO THE TWO YEAR DURATION FROM THE DATE OF PURCHASE AS DESCRIBED ABOVE.

Some states do not allow limitations on how long an implied warranty lasts, so the above limitation may not apply to you.



©2003 BISSELL Homecare, Inc.  
Grand Rapids, Michigan  
All rights reserved. Printed in USA.  
Part Number 310-4800  
Rev 1/03

Visit our website at:  
[www.bissell.com](http://www.bissell.com)  
Scotchgard a trademark of 3M