



ULTRA Series

(Catalog Numbers 1398-xxx)

Product Data



The 1398 ULTRA™ Series is a family of single-axis digital and positioning servo drives designed to offer flexibility and performance for a wide range of applications. The ULTRA 100™ and 200™ digital servo drives offer you versatility and ease of use. Using the Windows™-based Ultra Master software, you can quickly set up, commission, and troubleshoot ULTRA 100 and 200 drives. The ULTRA Plus positioning servo drives combine control and drive functionality to create powerful single-axis motion controllers. Using the graphical Windows-based GML™ Ultra software, you can quickly program, commission, and troubleshoot ULTRA Plus drives.

Table of Contents

ULTRA 100/200 Drives	5
ULTRA 100 Features	6
ULTRA 100 and DeviceNet	7
ULTRA 100 Specifications	7
General	7
Command Sources	8
DeviceNet	8
Serial Communication Port	8
Control Loops	8
Connectors	9
Environmental	9
Inputs and Outputs	10
ULTRA 200 Features	11
ULTRA 200 Specifications	12
General	12
Command Sources	13
Serial Communication Port	13
Control Loops	13
Inputs and Outputs	14
Connectors	14
Environmental	15
Mating Connector Kits	15
Mating Connectors	15
ULTRA Series 100/200 Cables	16
ULTRA 100 and 200 Interconnect Diagrams	17
Connector J1 — Controller Connection	18
Connector J2 — Encoder Connection	18
Connector J3 — Auxiliary Port Connection (For ULTRA 200 Drives)	18
Connectors J4 and J5 — Serial Ports Connections	19
Cable Specifications	19
Cable Installation Guidelines	19
System Configuration Checklist	20
ULTRA 100/200 Drives (choose one of the following):	20
ULTRA Series Motors (choose one of the following):	20
Cables:	21
Dimensions for 1398-DDM-005, -005X	24
Dimensions for 1398-DDM-005-DN, -005X-DN (Ultra 100 with DeviceNet)	25
Dimensions for 1398-DDM-009, -009X, -019, and -019X	26
Dimensions for 1398-DDM-009-DN, -009X-DN, -019-DN, and -019X-DN (Ultra 100 with DeviceNet)	27
Dimensions for 1398-DDM-010, -010X, -020, -020X, -030, and -030X	28
Dimensions for 1398-DDM-075 and -075X	29
Dimensions for 1398-DDM-150 and -150X	30
ULTRA 100/200 Drives Options and Accessories	31
Ultra Master	31
PC Requirements	31
DeviceNet Option	31

Host Mode	32
Ultra Master Windows	33
AC Line Filters	34
AC Line Filter (9101-1516) for 1398-DDM-005	34
AC Line Filter (9101-1517) for 1398-DDM-009, 1398-DDM-010, and 1398-PDM-10 10A 1f	35
AC Line Filter (9101-1518) for 1398-DDM-019, 1398-DDM-020, and 1398-PDM-20 23A 1f	36
AC Line Filter (9101-1575) for 1398-DDM-150 50A 3f	37
AC Line Filter (9101-1387) for 1398-DDM-030 and 1398-PDM-30 36A 1f	38
AC Line Filter (9101-1388) for Multiple Drives 50A 1f	38
AC Line Filter (9101-1389) for 1398-DDM-075 and 1398-PDM-75 36A 3f	39
AC Line Filter (9101-1390) for Multiple Drives 80A 3f	39
AC Line Filter (9101-1575) for 1398-DDM-150 50A	40
External Shunt Resistor Kit (9101-1183) for 1398-DDM-010, -020, -030 and 1398-PDM-10, -20, -30	40
Passive External Shunt Module (1398-SR9P) for 1398-DDM-075, 1398-DDM-150, and 1398-PDM-075	41
Active External Shunt Module (1398-SR3AF) for 1398-DDM-005, -005-DN, -005X, -005X-DN 1398-DDM-009, -009-DN, -009X, -009X-DN, and 1398-DDM-019, -019-DN, -019X, -019X-DN	42
Breakout Board (J1) for ULTRA 100/200 Drives (9101-1391)	42
Breakout Board (J2) for ULTRA 100/200 Drives (9101-1392)	43
TouchPad	43
TouchPad (1398-HMI-001)	44
ULTRA Plus Positioning Drives	45
ULTRA Plus Features	46
ULTRA Plus General Specifications	47
Control Hardware	47
Resolutions, Ranges, Accuracy, and Speeds	48
Serial I/O	48
Tuning and Compensation	48
ULTRA Plus Specifications Specific to 1398-PDM-10, -20, -30, and -75	49
General	49
ULTRA Plus External Shunt Resistor for 1398-PDM-10, -20, and -30 (9101-1183)	49
ULTRA Plus Specifications Specific to 1398-PDM-25, -50, -100, and -150	50
General	50
Power Supply Modules	50
Operator Terminal	50
Block Diagram of the ULTRA Plus Positioning Module	51
Ultra Plus Interconnect Diagram	52
System Configuration Checklist	53
ULTRA Plus Drives 1	53
Power Supply Modules	53

ULTRA Series Motors	53
Cables	54
Accessories	56
Mating Connectors.	56
Dimensions for 1398-PDM-10, -20, and -30	57
Dimensions for 1398-PDM-75	58
Dimensions for 1398-PDM-25, -50, -100, and -150	59
ULTRA Plus Drives Options and Accessories.	60
GML Ultra for Windows	60
PC Configuration	60
GML Ultra Windows.	61
ULTRA Plus Requirements for Compliance with European Directives	61
24V Sourcing I/O Conversion Card (9103-0152) and Cables	62
AC Line Filters	62
Shielded Power Cables	63
ULTRA Plus Optional Cables	63
ULTRA Plus Transformer (0020-5093) and Power Supply (9101-0120) for 1398-PDM-25, -50, -100, and -150	64
Power Supply Module Selection Guidelines (1398-PSM-25, -50, -100, and -150)	64
ULTRA Plus Operator Terminal	65
ULTRA Series Common Accessories.	66
Operator Terminal (1398-HMI-002)	66
AC Line Filter (9101-1387) for 1398-DDM-030 and 1398-PDM-30 36A 1f	67
AC Line Filter (9101-1388) for Multiple Drives 50A 1f	67
AC Line Filter (9101-1389) for 1398-DDM-075 and 1398-PDM-75 36A 3f	68
AC Line Filter (9101-1390) for Multiple Drives 80A 3f	68
AC Line Filter (9101-1517) for 1398-DDM-009, 1398-DDM-010, and 1398-PDM-10 10A 1f	69
AC Line Filter (9101-1518)for 1398-DDM-019, 1398-DDM-020, and 1398-PDM-20 23A 1f	70
External Shunt Resistor Kit (9101-1183) for 1398-DDM-010, -020, -030 and 1398-PDM-10, -20, -30	70
Passive External Shunt Module (1398-SR9P) for 1398-DDM-075, 1398-DDM-150, and 1398-PDM-075	71

ULTRA 100/200 Drives

ULTRA 100 and 200 drives are feature-rich, high-performance drives that offer the flexibility to handle a wide range of applications. You can set up the ULTRA 100/200 drives as indexing drives, velocity servo drives, stepper drives, or master encoder followers. With the DeviceNet option, you can remotely commission and reprogram ULTRA 100 drives. In addition, you can use the ULTRA 100/200 drives host command protocol to set up multiple drives. Available in seven power ranges, the ULTRA 100/200 drives can be mated to four high-performance brushless servo motor lines. Ultra Master software, a Windows-based interface, provides you with a familiar programming environment and a powerful commissioning tool for all ULTRA 100/200 drives.

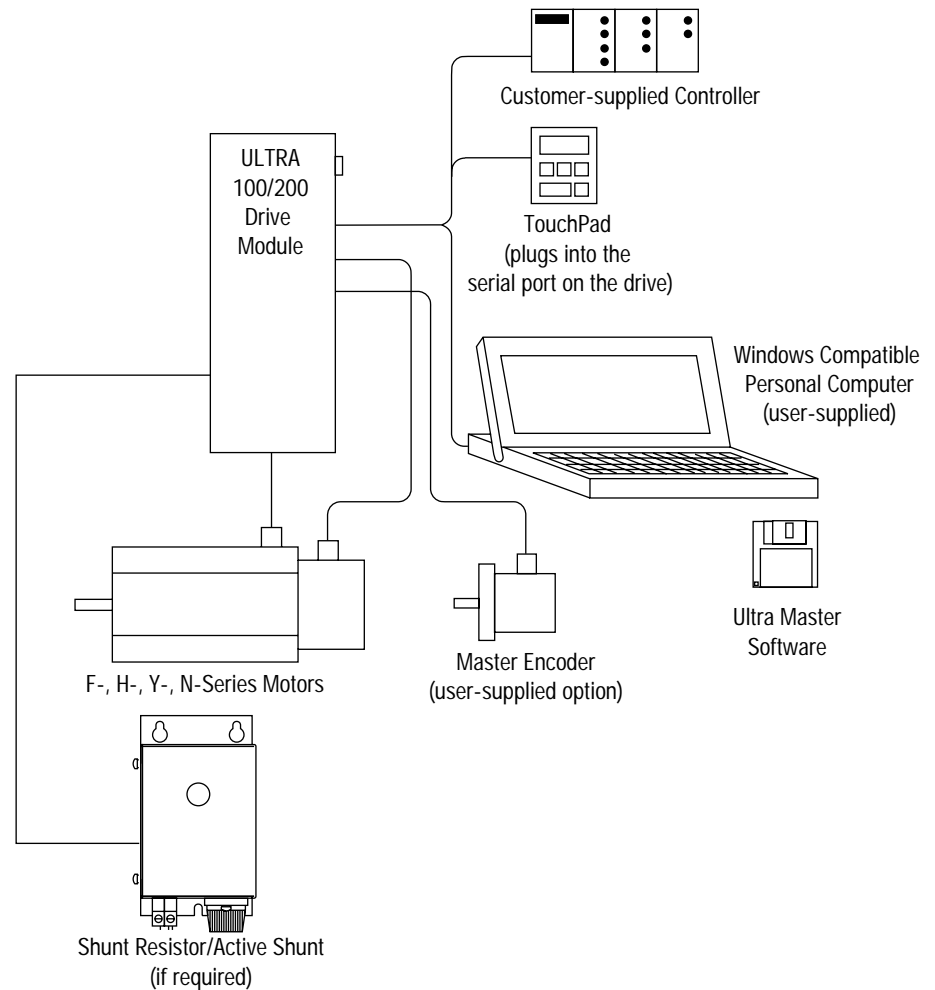

Note: To learn more about 1398 ULTRA Series 230V brushless servo motors, see publication 1398-2.1.



ULTRA 100 Features

ULTRA 100 servo drives deliver flexibility and performance in a very compact size. Each ULTRA 100 drive provides:

- 115/230V AC, single-phase input
- Built-in logic power supplies (external 12 to 24V I/O logic power required)
- The ability to drive sinusoidal AC brushless motors
- Advanced control algorithms for leading-edge velocity loop bandwidth, fully digital current, velocity, and position loops
- A 14-bit A/D convertor for velocity command input
- An internally-shielded filter for electromagnetic compatibility (EMC)
- Several analog or digital command interfaces:
 - Indexing—absolute with the Homing feature, incremental, or registration (optional)
 - DeviceNet (optional)
 - ± 10 Volt analog interface—position, velocity, or torque control
 - Presets (from one to eight binary inputs)—torque or velocity control
 - Quadrature encoder digital interface—electronic gearing position follower
 - Step/direction digital interface—position control
 - CW/CCW (step up/step down) interface—position control
 - Operating mode override—alternate movement interface
- Four dedicated I/O plus six user-selectable, optically isolated digital inputs and outputs (sourcing/active high):
 - Two dedicated inputs
 - Two dedicated outputs
 - Four user-selectable inputs
 - Two user-selectable outputs
- One analog input for external current limit
- One analog output for variable monitoring or torque sharing
- Unlimited I/O capability over DeviceNet
- A serial port for RS-232/RS-485 host communication

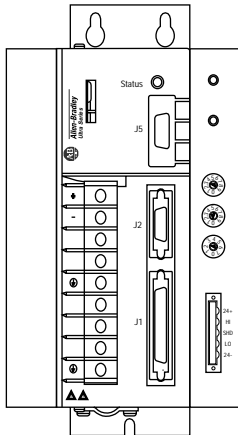

ULTRA 100 and DeviceNet

The DeviceNet interface card is an optional card that provides a direct, digital connection between a DeviceNet network and an ULTRA 100 drive.

The DeviceNet option provides:

- Two bi-colored LEDs for network and module status
- Three switches to set node addresses and baud rate
- Several message protocols
 - Explicit messaging
 - Polled I/O messaging
 - Change-of-state/cyclic messaging

ULTRA 100 Specifications

The following tables contain ULTRA 100 specifications:

General

Specification	1398-DDM-		
	005, 005X ¹ , 005-DN ² , 005X-DN	009, 009X ¹ , 009-DN ² , 009X-DN	0019, 0019X ¹ , 0019-DN ² , 0019X-DN
Peak output current	7.5A	15A	30A
Continuous output current	2.5A	5A	10A
Continuous output power	0.5 kW	1.0 kW	2.0 kW
Continuous input current	5A	9A	18A
Input voltage	100 to 240V AC RMS nominal (88 to 265 Volts), single phase		
Input frequency	47-63 Hz		

¹ The X indicates the indexing version of the drive.
² The DN denotes the DeviceNet option.

Command Sources

Specification	Description
Analog velocity/torque input	± 10 Volts
Presets	8 presets, binary selection by digital inputs (unlimited I/O capability over DeviceNet)
Step and direction, step up/step down	1 MHz maximum frequency Differential or single-ended line drivers
Master encoder following	1 MHz maximum line frequency Differential or single-ended line drivers
Digital serial commands	Via serial port and ULTRA Series host language
DeviceNet commands	Via DeviceNet port
Indexing	Absolute (with Homing feature) Incremental Registration (with high-speed registration)

DeviceNet

Specification	Description
Baud rate	125 kps (default), 250 kps, or 500 kps
Multiple drive addressing	00-63 (63 default)
Power consumption (DeviceNet current draw)	60 mA

Serial Communication Port

Specification	Description
Type	RS-232, four-wire RS-485
Baud rate	1,200 to 19,200 baud
Multiple drive addressing	Up to 32 drives ¹

¹ You can use the Ultra Master software to setup multiple drives using the ULTRA 100/200 drives host command protocol.

Control Loops

Specification	Description
Modes	Torque, velocity, and position control
Type	All loops are digital.
Velocity loop bandwidth (maximum)	300 Hz
Position loop	1 ms
Current loop	125 μs

Connectors

Specification	Description
DeviceNet	5-pin open-style connector
Serial	9-pin D-shell (for J5)
Control and feedback	20-pin (for J2) and 50-pin (for J1) high density Mini D
Power	Screw terminal block (for TB1)

Environmental

Specification	1398-DDM-		
	005, 005X ¹ , 005-DN ² , 005X-DN	009, 009X ¹ , 009-DN ² , 009X-DN	0019, 0019X ¹ , 0019-DN ² , 0019X-DN
Storage temperature	-40°C to 70°C (-40°F to 158°F)		
Operating temperature	-5°C to 55°C (23°F to 131°F)		
Humidity	5% to 90%, non-condensing		
Altitude	1500m (5000 ft)		
Vibration	10 to 2000 Hz at 2g		
Shock	15g, 11 ms, half sine		
Weight	1.68 kg (3.7 lb) ³	2.03 kg (4.47 lb) ³	2.0 kg (4.4 lb) ³

¹ The X indicates the indexing version of the drive.

² The DN denotes the DeviceNet option.

³ The DeviceNet option adds 0.16 kg (0.35lb).

Inputs and Outputs

Specification	Description
Selectable digital inputs	<p>4 optically isolated, 12 to 24 volt, active high. User-selectable as:</p> <ul style="list-style-type: none"> • Analog override • Drive mode select • Fault reset • Forward enable • Preset select • Reverse enable • Starting homing • Define home • Integrator inhibit • Follower enable • Mode override • Registration sensor¹ • Remove command offset • Start index
Selectable digital outputs	<p>2 optically isolated, 12 to 24 volt, active high, short circuit protected. User-selectable as:</p> <ul style="list-style-type: none"> • At speed • Bus charged • Disabling fault • In dwell • In position • Sequence complete • Within speed window • various fault indications • Axis homed • Current limit • Drive enable • In motion • Registered • Within position window • Zero speed
Dedicated digital inputs	Enable, Fault Reset (optically isolated, 12-24 Volt, active high)
Dedicated relay outputs	Ready/Not Faulted, Brake Output
Analog inputs	1 external analog current limit, 0 to 10 Volt 10-bit resolution
Analog outputs	1 user programmable, ± 10 Volt
Encoder output	1 MHz maximum line frequency Differential line drivers Scalable by 1, $1/2$, $1/4$, $1/8$
Motor feedback	Incremental encoder

¹ You must use input 2 as the high-speed input.



ULTRA 200 Features

ULTRA 200 positioning drives deliver full-featured flexibility and impressive power and performance. Each ULTRA 200 drive provides:

- 115 to 230V AC single phase input (single phase or three phase for the 75 amp version, three phase only for the 150 amp version)
- Phase-to-phase and phase-to-ground short circuit protection
- An internal resistive shunt
- A built-in auxiliary AC input (to power logic only)
- Built-in power supplies (including 24V I/O supply)—no external source required (except AC line)
- The ability to drive sinusoidal AC brushless motors
- An DC bus available externally for power leveling or for use of shared power supplies
- Advanced multi-processor design for leading-edge velocity loop bandwidth, fully digital current, velocity, and position loops
- Large-scale integration with custom ASICs and IPMs for performance and reliability
- A 16-bit A/D convertor for precise velocity command input
- Flash memory for simple field upgrades
- A personality module to store setup parameters and simplify drive replacement
- Reduced component count for reliability
- Internally-shielded filters for electromagnetic compatibility (EMC)
- Four dedicated I/O plus eight user-selectable, optically isolated digital inputs and outputs (sourcing/active high):
 - Two dedicated inputs
 - Two dedicated outputs
 - Four user-selectable inputs
 - Four user-selectable outputs
- Two analog inputs for external current limit
- Two analog outputs for variable monitoring or torque sharing

- Two serial connectors to simplify RS-485 multi-dropping and host communications
- Several analog or digital command interfaces:
 - Indexing (absolute with the Homing feature, incremental, or registration)
 - ± 10 Volt analog interface—position, velocity, or torque control
 - Presets (from one to eight binary inputs)—torque or velocity control
 - Quadrature encoder digital interface—electronic gearing position follower
 - Step/Direction digital interface—position control
 - CW/CCW (step up/step down) interface—position control
 - Operating mode override—alternate movement interface
 - Host command digital interface

ULTRA 200 Specifications

The following tables contain ULTRA 200 specifications:

General

Specification	1398-DDM-				
	010, 010X ¹	020, 020X ¹	030, 030X ¹ (1 ϕ input)	075, 075X ¹ 3 ϕ (1 ϕ)	150, 150X ¹ (3 ϕ input)
Peak output current	10A	20A	30A	75A (50A)	150A
Internal continuous output current	5A	10A	15A	35A (15A)	65A
Internal continuous output power	1.0 kW	2.0 kW	3.0 kW	7.5 kW (3.0 kW)	15 kW
Internal continuous shunt power	50W	50W	50W	50W	180W
Internal peak shunt power	4.5 kW	4.5 kW	4.5 kW	10.0 kW	18.0 kW
Continuous input current	10A	19A	28A	28A	46A
Input voltage	100 to 240V AC RMS nominal (88 to 265 Volts)				
Input frequency	47-63 Hz				

¹ The X indicates the indexing version of the drive.

Command Sources

Specification	Description
Analog velocity input	±10 Volts, 16-bit resolution
Presets	8 presets, binary selection by digital inputs
Step and direction, Step up/Step down	1 MHz maximum frequency Differential or single-ended line drivers
Master encoder following	1 MHz maximum line frequency Differential or single-ended line drivers
Digital serial commands	Via serial port and ULTRA Series host language
Indexing	Absolute (with Homing feature) Incremental Registration (with high-speed registration)

Serial Communication Port

Specification	Description
Type	RS-232, four-wire RS-485 (for multidrop connections)
Baud rate	1,200 to 19,200 baud
Multiple drive addressing	Up to 32 drives, 10 using front panel rotary dip switch

Control Loops

Specification	Description
Modes	Torque, velocity, and position control
Type	All loops are digital.
Velocity loop bandwidth (maximum)	400 Hz
Position loop	1 ms
Current loop	100 μ s

Inputs and Outputs

Specification	Description
Selectable digital inputs	<ul style="list-style-type: none"> • Analog override • Drive mode select • Follower enable • Integrator inhibit • Mode override • Remove command offset • Start index • Define home • Fault reset • Forward enable • Preset select • Registration sensor • Reverse enable • Start homing
Selectable digital outputs	<p>4 optically isolated, 12 to 24 volt, active high User-selectable as:</p> <ul style="list-style-type: none"> • At speed • Bus changed • Disabling fault • In dwell • In position • Sequence complete • Within speed window • various fault indications • Axis homed • Current limit • Drive enabled • In motion • Registered • Within position window • Zero speed
Dedicated digital inputs	Enable, Fault Reset (optically isolated, 24 Volt, active high)
Dedicated relay outputs	Ready/Not Faulted, Brake Output
Analog inputs	2 external analog current limits, 0 to 10 Volt 10-bit resolution
Analog outputs	2 user programmable, ± 10 Volt 8-bit and 12-bit resolution
Encoder output	1 MHz maximum line frequency Differential line drivers Scalable by 1, $1/2$, $1/4$, $1/8$
Motor feedback	Incremental encoder

Connectors

Specification	Description
Serial	9-pin D-shell (for J4 and J5)
Control and feedback	20-pin (J2), 26-pin (J3) and 50-pin (J1) high density Mini D
Power	Screw terminal block (TB1)

Environmental

Specification	1398-DDM-				
	010, 010X ¹	020, 020X ¹	030, 030X ¹ (1 ϕ input)	075, 075X ¹ 3 ϕ (1 ϕ)	150, 150X ¹ (3 ϕ input)
Storage temperature	-40°C to 70°C (-40°F to 158°F)				
Operating temperature	-5°C to 55°C (23°F to 131°F)				-5°C to 50°C (23°F to 122°F)
Humidity	5% to 95%, non-condensing				
Altitude	1500m (5000 ft)				
Vibration	10 to 2000 Hz at 2g				
Shock	15g, 11 ms, half sine				
Weight	5.80 kg (13.78 lb)	6.36 kg (14.02 lb)	6.48 kg (14.28 lb)	9.67 kg (21.32 lb)	14.06 kg (30.9 lb)

¹ The X indicates the indexing version of the drive.

Mating Connector Kits

Connector Kit	Catalog Number
J1 50-pin mini D, 24-30 AWG, solder cup, squeeze latch	9101-1476
J2 20-pin mini D, 24-30 AWG, solder cup, squeeze latch	9101-1477
J3 26-pin mini D, 24-30 AWG, solder cup, squeeze latch	9101-1478
J5 (or J4 for ULTRA 200 drives) 9-pin D shell, solder cup	9101-1479

Mating Connectors

Cross-reference of mating connectors with J1, J2, and J3 connectors on your drive. Connectors are crimp style.

Option		J1	J2	J3	Style
1	Connector	AMP 2-175677-7	AMP 2-175677-2	AMP 2-175677-4	Crimp ¹
	Backshell	AMP 176793-7	AMP 176793-2	AMP 176793-4	
2	Connector	3M 10150-6000EC	3M 10120-6000EC	3M 10126-6000EC	Crimp ¹
	Backshell	3M 10350-A200-00	3M 10320-A200-00	3M 10326-A200-00	
3	Connector	3M 10150-3000VE	3M 10120-3000VE	3M 10126-3000VE	Solder
	Backshell	3M 10350-52F0-008	3M 10320-52F0-008	3M 10326-52F0-008	

¹ For use with MDR Hand Press Tool Kit, 3M part number 3829.

ULTRA Series 100/200 Cables

Use the following table to determine which cables you need for your application. Refer to the *ULTRA 100 and 200 Interconnect Diagrams* section on page 17 for cable location.

	Interface Cables	Part Number
①	J1 to customer-supplied connector	9101-1370-xxx
	J1 to a 50-position female D-sub cable (1m/3 ft length)	9101-1369-003
	J1 to 1756-MO2AE ControlLogix Analog/Encoder	1398-CCAExx
	J1 to 1756-MO2AE flying lead to ULTRA 100/200 molded connector, single axis (10 ft.)	1398-CFLAExx
	J3 to customer-supplied connector	9101-1368-xxx
	J3 to J3 (for slaving drives or torque sharing [0.3m, 1 ft])	9101-1463-002
Serial Interface Cables¹		
②	J4 or J5 to PC (RS-232 9-pin D-shell connector)	9101-1372-xxx
	J4 or J5 to customer-supplied connector	9101-1379-xxx
	J4 or J5 to J4 or J5 (RS-485 multi-drop communications) (30 cm/1 ft length)	9101-1374-001
Encoder Feedback Cables		
③	J2 to F- or H-Series motors	9101-1366-xxx
	F- or H-Series motor to customer-supplied connector (pig tail)	9101-1365-xxx
	J2 to Y-Series motor	9101-1375-xxx
	Y-Series motor to customer-supplied connector (pig tail)	9101-1373-xxx
	J2 to N-Series motor	9101-1468-xxx
	N-Series motor to customer-supplied connector (pig tail)	9101-1469-xxx
	J2 to a 20-position female D-sub cable (1m/3ft length)	9101-1371-003
J2 to customer-supplied connector (pig tail)	9101-1380-xxx	
Breakout Boards		
④	J1 to 50-pin terminal strip (includes 3ft/1m cable and mounting hardware)	9101-1391
	J2 to 25-pin terminal strip (includes 3ft/1m cable and mounting hardware)	9101-1392
Motor Power Cables		
⑤	Drive to 2000 or 3000 Series motors (F- or H-Series)	9101-1381-xxx
	Drive to 4000 Series motors (F- or H-Series)	9101-1382-xxx
	Drive to 6000 Series motors (F- or H-Series)	9101-1383-xxx
	Drive to 8000 Series motors (F- or H-Series)	9101-1384-xxx
	Drive to Y-Series motors	9101-1385-xxx
	1398-DDM-150, -150 drive to 6300 Series motors (F- or H-Series)	9101-1399-xxx
	Drive to N-Series motors	9101-1467-xxx

¹ Serial interface cables for use with the ULTRA 100 drives cannot exceed 50 ft (15 m).

Note: xxx — Last three digits select standard cable length of 10 ft (3.0 m)—010; 25 ft (7.7 m)—025; 50ft (15.0 m)—050; 75 ft (25 m)—075; 100 ft (30.3 m)—100.

ULTRA 100 and 200 Interconnect Diagrams

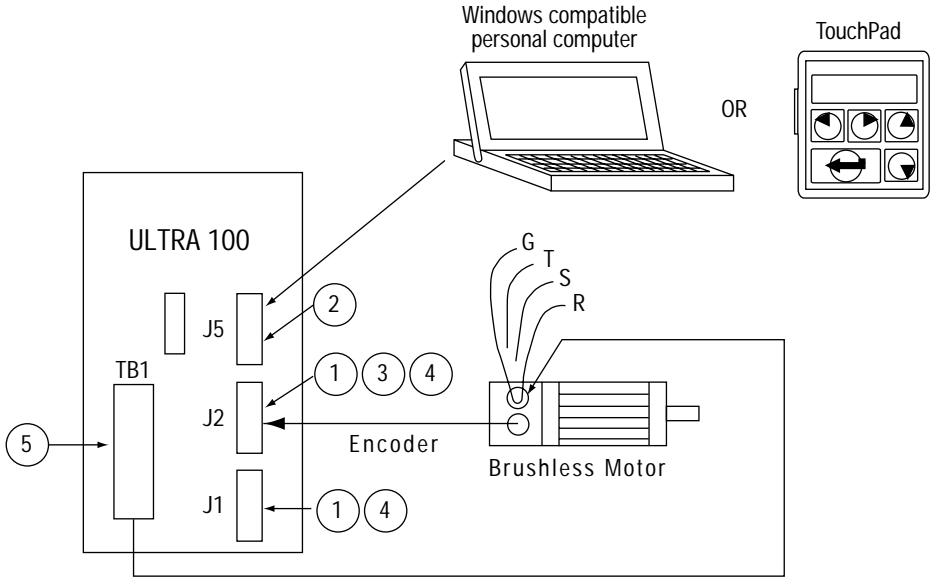

Note: J1, J2, and J5 are the same as ULTRA 200.

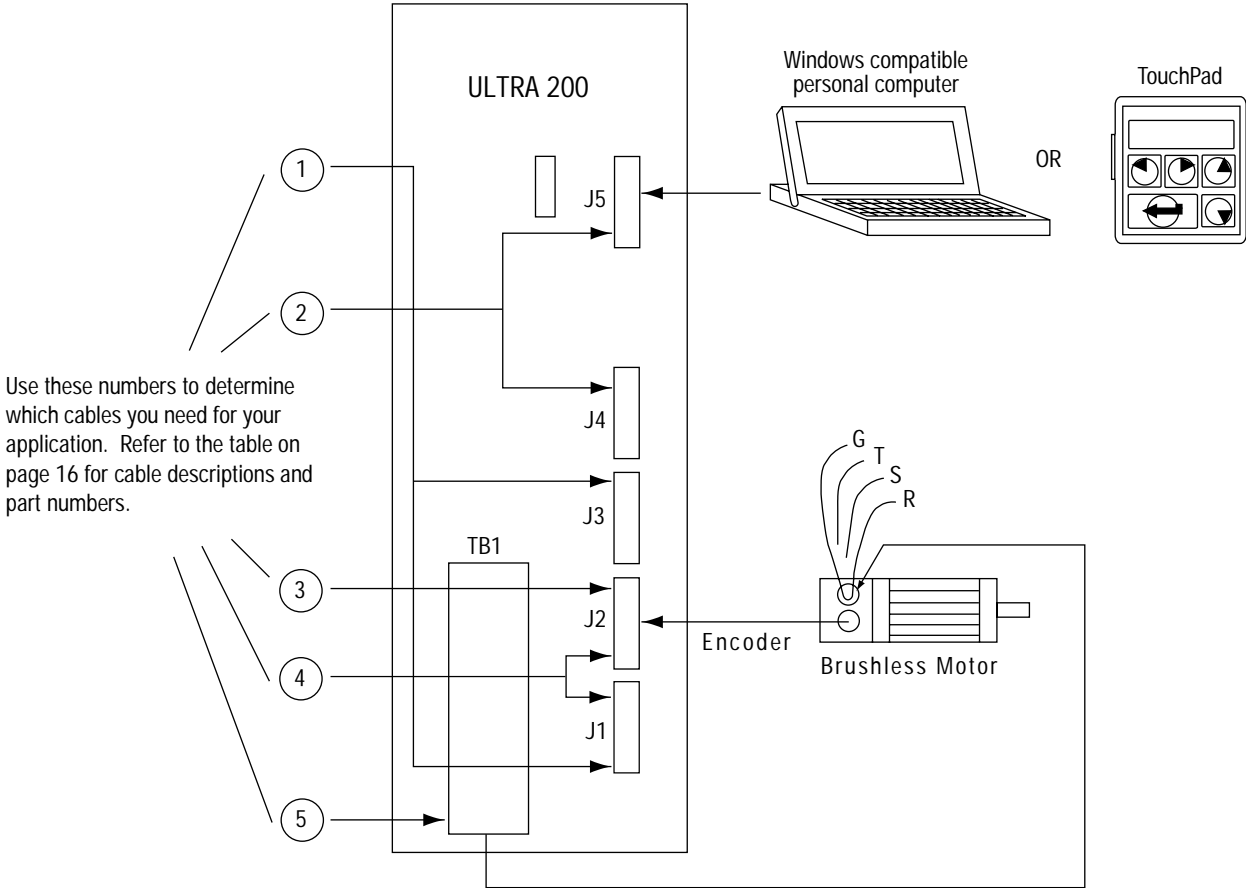

Connector J1 — Controller Connection

Pin	Description	Pin	Description	Pin	Description	Pin	Description
1	Encoder +5V DC	14	Auxiliary channel A+	27	Current limit	39	RSVD
2	Encoder com	15	Auxiliary channel A-	28	Analog com	40	RSVD
3	Encoder +5V DC	16	Auxiliary channel B+	29	Negative current limit ¹	41	RSVD
4	Encoder com	17	Auxiliary channel B-	30	Analog output 1	42	Selectable output 1
5	Isolated +12 to 24V DC	18	Auxiliary index A+	31	Analog output 2 ¹	43	Selectable output 2
6	Isolated +12 to 24V Com	19	Auxiliary index A-	32	Selectable input 1	44	Selectable output 3 ¹
7	Motor output channel A+	20	Drive enable	33	Selectable input 2	45	Selectable output 4 ¹
8	Motor output channel A-	21	Fault reset	34	Selectable input 3	46	RSVD
9	Motor output channel B+	22	Analog cmd +	35	Selectable Input 4	47	RSVD
10	Motor output channel B-	23	Analog cmd -	36	RSVD	48	RSVD
11	Motor output index +	24	Drive ready +	37	RSVD	49	Brake enable +
12	Motor output index -	25	Drive ready -	38	RSVD	50	Brake enable -
13	Isolated 12 to 24V com	26	Isolated +12 to 24V DC				

¹ Reserved on ULTRA 100 drives.

Connector J2 — Encoder Connection

Pin	Description	Pin	Description	Pin	Description	Pin	Description
1	Encoder pwr	6	Encoder pwr sense -	11	Motor encoder input chnl I+	16	Absolute position
2	Encoder com	7	Motor encoder input chnl A+	12	Motor encoder input chnl I-	17	RSVD
3	Encoder pwr	8	Motor encoder input chnl A-	13	Hall A	18	RSVD
4	Encoder com	9	Motor encoder input chnl B+	14	Hall B	19	Thermal switch +
5	Encoder pwr sense +	10	Motor encoder input chnl B-	15	Hall C	20	Thermal switch -

Connector J3 — Auxiliary Port Connection (For ULTRA 200 Drives)

Duplicates connector J1 pins 1 through 26.

Connectors J4 and J5 — Serial Ports Connections

Pin	Description		Pin	Description		Pin	Description		Pin	Description	
1	RCV+	RS-485	4	XMT+	RS-485	6	RSVD		8	XMT-	RS-485
2	RCV	RS-232	5	COM		7	RCV-	RS-485	9	RSVD	
3	XMT	RS-232									

Cable Specifications

Specification	Description
Wire insulation type	Polyvinyl chloride
Conductor size	28 AWG (0.08 mm ²) tinned copper 24 AWG (0.25 mm ²) for 9101-1372- <i>xxx</i> , -1374- <i>xxx</i> , and -1379- <i>xxx</i> 16 AWG (1.5 mm ²) for 9101-1381- <i>xxx</i> , -1385- <i>xxx</i> , and -1467- <i>xxx</i> 14 AWG (2.5 mm ²) for 9101-1382- <i>xxx</i> 10 AWG (6 mm ²) for 9101-1383- <i>xxx</i> 8 AWG (10 mm ²) for 9101-1384- <i>xxx</i> . 9101-1399- <i>xxx</i>
Braid sheet coverage	85% minimum
Jacket material	Thermoplastic elastomer — oil and chemical resistant
Moldings	105°C (221°F) black PVC
Minimum bend radius	Control cables: J1: 171 mm (6.75 in.) J2: 130 mm (5.1 in.) J3: 130 mm (5.1 in.) Motor power cables: 9101-1381- <i>xxx</i> : 137 mm (5.4 in.) minimum 9101-1382- <i>xxx</i> : 147 mm (5.8 in.) minimum 9101-1383- <i>xxx</i> : 234 mm (9.2 in.) minimum 9101-1384- <i>xxx</i> : 227 mm (8.9 in.) minimum 9101-1385- <i>xxx</i> : 107 mm (4.2 in.) minimum 9101-1399- <i>xxx</i> : 227 mm (8.9 in.) minimum 9101-1467- <i>xxx</i> : 91 mm (3.6 in.) minimum
Flex rating	Allen-Bradley cables for encoder feedback and motor power connections are tray-rated (stationary) and should only be used for one-time flex applications(not flex rated).

Cable Installation Guidelines

Follow the guidelines below to maintain cable reliability.

- Always follow the installation instructions of the cable carrier manufacturer.
- Remove twists, bends, and kinks from the cable before installing it in the cable carrier.
- It is important to lay out the cabling at least 24 hours before installation to relax any stresses resulting from transit or storage.

- When placing the cable into the cable carrier, the carrier should be laid out flat with the bending direction facing upward. It should then be fitted with the cables in working position. The cables should be laid into the cable carrier and not woven between or around other cables.
- Allow at least 10% clearance between cables so that they are free to move. Use separators between cables.
- The cables must be free to move within the carrier. Do not attach the cables to the carrier or to each other.
- Clamp heavier cables toward the edge of the track and lighter cables in the center of the track.
- Do not pull cables tight against the inner/outer track curves.

System Configuration Checklist

Use the following checklist to configure an ULTRA 100/200 system for your application:

ULTRA 100/200 Drives (choose one of the following):

ULTRA 100 Drives ¹

- 1398-DDM-005, -005-DN
1398-DDM-005X, -005X-DN
- 1398-DDM-009, -009-DN
1398-DDM-009X, -009X-DN
- 1398-DDM-019, -019-DN
1398-DDM-0019X, -0019X-DN

ULTRA 200 Drives ²

- 1398-DDM-010, -010X
- 1398-DDM-020, -020X
- 1398-DDM-030, -030X
- 1398-DDM-075, -075X
- 1398-DDM-150, -150X

¹ Includes the *ULTRA 100 Installation Manual* (Publication 1398-5.2).

² Includes the *ULTRA 200 Installation Manual* (Publication 1398-5.0).

ULTRA Series Motors (choose one of the following):

F-Series Motors

- F-4030-Q-H00AA
- F-4050-Q-H00AA
- F-4075-R-H00AA¹
- F-6100-R-H00AA¹
- F-6200-R-H00AA¹

H-Series Motors

- H-2005-K-H00AA
- H-3007-N-H00AA
- H-3016-N-H00AA
- H-4030-M-H00AA¹
- H-4030-P-H00AA

Y-Series Motors

- Y-1002-1-H00AA
- Y-1002-2-H00AA
- Y-1003-1-H00AA
- Y-1003-2-H00AA
- Y-2006-1-H00AA

N-Series Motors

- N-2302-1-F00AA
- N-2304-1-F00AA
- N-3406-2-H00AA
- N-3412-2-F00AA²
- N-3412-2-H00AA¹

F-Series Motors F-6300-R-H00AA¹**H-Series Motors** H-4050-P-H00AA¹ H-4075-R-H00AA¹ H-6100-Q-H00AA¹ H-6200-Q-H00AA¹ H-6300-Q-H00AA¹ H-8350-S-H00AA¹ H-8500-S-H00AA¹**Y-Series Motors** Y-2006-2-H00AA Y-2012-1-H00AA Y-2012-2-H00AA Y-3023-2-H00AA**N-Series Motors** N-4214-2-H00AA N-4220-2-H00AA N-5630-2-H00AA N-5637-2-H00AA N-5647-2-H00AA¹ ULTRA 200 drives only.² ULTRA 100 drives only**Cables:**

Note: The last three digits select standard cable lengths of:
 10 ft (3.0m)—010; 25 ft (7.7m)—025; 50 ft (15.0m)—050;
 75 ft (23.0m)—075; 100 ft (31m)—100.

TB1 to Motor Power Connections (choose one of the following):

	Part Number	Description
<input type="checkbox"/>	9101-1381-xxx	Use for H-2000 and H-3000 motors
<input type="checkbox"/>	9101-1382-xxx	Use for F-4000 and H-4000 motors
<input type="checkbox"/>	9101-1383-xxx	Use for F-6000 and H-6100, H-6200 motors Use for F-6300 and H-6300 with 1398-DDM-075
<input type="checkbox"/>	9101-1384-xxx	Use for H-8000 motors
<input type="checkbox"/>	9101-1385-xxx	Use for Y-Series motors
<input type="checkbox"/>	9101-1399-xxx	Use for 1398-DDM-150, -150X with F-6300 and H-6300 motors
<input type="checkbox"/>	9101-1467-xxx	Use for N-Series motors

J1 to Controller Connections (choose one of the following):

	Part Number	Description
<input type="checkbox"/>	9101-1369-003	J1 to a 50-position female D-sub cable (1m/3 ft length) This cable is included in the 9101-1391 kit.
<input type="checkbox"/>	9101-1370-xxx	J1 cable with flying lead opposite (rail mounted)
<input type="checkbox"/>	9101-1391	J1 to 50-pin terminal strip (includes 1 m/3 ft cable and mounting hardware)
<input type="checkbox"/>	1398-CCAE _{xx}	J1 to 1756-M02AE ControlLogix Analog/Encoder Card (includes 39-pin connector with no hood)
<input type="checkbox"/>	1398-CFLAE _{xx}	J1 to 1756-M02AE ControlLogix Analog/Encoder single axis flying lead

J2 to Motor Encoder Connections (choose one of the following):

	Part Number	Description
<input type="checkbox"/>	9101-1365-xxx	F- and H-Series motors connector cable with flying leads opposite
<input type="checkbox"/>	9101-1366-xxx	J2 to motor (F- and H-Series motors)
<input type="checkbox"/>	9101-1371-003	J2 to a 20-position female D-sub cable (1m/3 ft length) This cable is included in the 9101-1392 kit.
<input type="checkbox"/>	9101-1373-xxx	Y-Series motor connector cable with flying leads opposite
<input type="checkbox"/>	9101-1375-xxx	J2 to motor (Y-Series motors)
<input type="checkbox"/>	9101-1380-xxx	J2 to customer supplied connector
<input type="checkbox"/>	9101-1392	J2 to 25-pin terminal strip (includes 1m/3 ft cable and mounting hardware)
<input type="checkbox"/>	9101-1468-xxx	J2 to motor (N-Series motor)
<input type="checkbox"/>	9101-1469-xxx	N-Series motor connector cable with flying leads opposite

J3 Connections (choose one of the following for ULTRA 200 drives):

	Part Number	Description
<input type="checkbox"/>	9101-1368-xxx	J3 to customer-supplied connector
<input type="checkbox"/>	9101-1463-002	J3 to J3 (for slaving drives or torque sharing)

J4 and J5 Connections:

	Part Number	Description
<input type="checkbox"/>	9101-1372-xxx	J4 or J5 to PC (RS-232 9-pin D-shell connector)
<input type="checkbox"/>	9101-1374-001	J5 to J4 (RS-485 multi-drop communications) (30 cm/1 ft)
<input type="checkbox"/>	9101-1379-xxx	J4 or J5 to customer-supplied connector (RS-232/RS-485)
<input type="checkbox"/>	1398-HMI-001	TouchPad that fits into the J5 position

Accessories (choose all that apply):

	Part Number	Description
<input type="checkbox"/>	9101-1387	AC line filter (36A, 1 ϕ) for 1398-DDM-030, -030X, -075, -075X
<input type="checkbox"/>	9101-1388	AC line filter (50A, 1 ϕ) for 1398-DDM-075, -075X
<input type="checkbox"/>	9101-1389	AC line filter (36A, 3 ϕ) for 1398-DDM-075, -075X
<input type="checkbox"/>	9101-1390	AC line filter (80A, 3 ϕ) for 1398-DDM-075, -075X
<input type="checkbox"/>	9101-1516	AC line filter (6A, 1 ϕ) for 1398-DDM-005, -005X

	Part Number	Description
<input type="checkbox"/>	9101-1517	AC line filter (10A, 1 ϕ) for 1398-DDM-009, -009X, -010, -010X
<input type="checkbox"/>	9101-1518	AC line filter (23A, 1 ϕ) for 1398-DDM-019, -019X, -020, -020X
<input type="checkbox"/>	9101-1575	AC line filter (50A, 3 ϕ) for 1398-DDM-150, -150X
<input type="checkbox"/>	9101-1183	External shunt resistor for 1398-DDM-010, -10X, -020, -020X, -030 and -030X
<input type="checkbox"/>	Master-D-U	Ultra Master software for ULTRA 100/100X and ULTRA 200/200X
<input type="checkbox"/>	1398-SR3AF	Ultra 100 active external shunt module
<input type="checkbox"/>	1398-SR9P	Ultra 200 passive shunt module (DDM-010, -020, -030, PDM-010, -020 and -030)

Dimensions for 1398-DDM-005, -005X

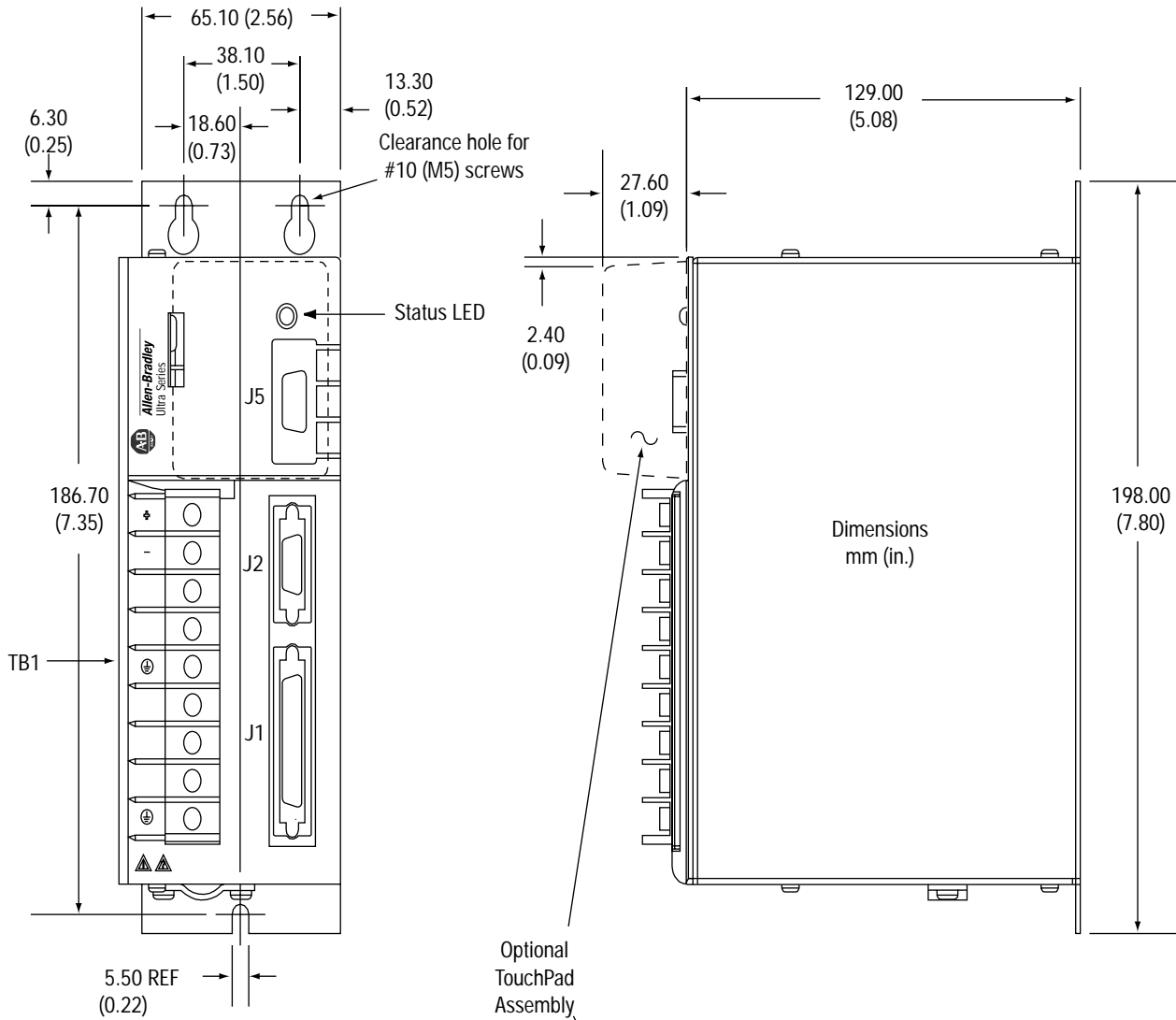

Optional TouchPad Assembly

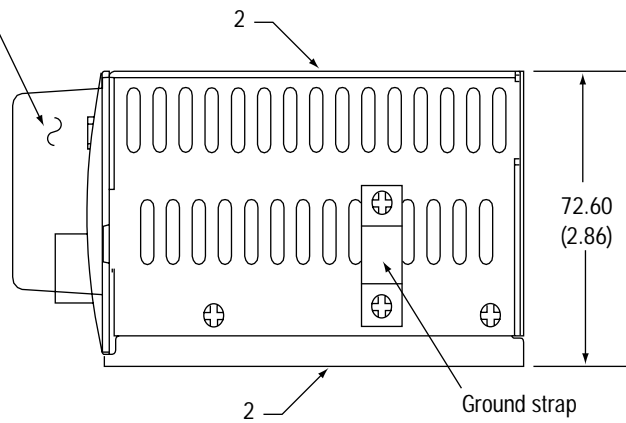

Notes:

1. Allow 76.2 mm (3.00 in.) clearance in front of unit for cables.
2. Allow 12.7 mm (0.50 in.) on both sides of the unit.

Dimensions for 1398-DDM-005-DN, -005X-DN (Ultra 100 with DeviceNet)

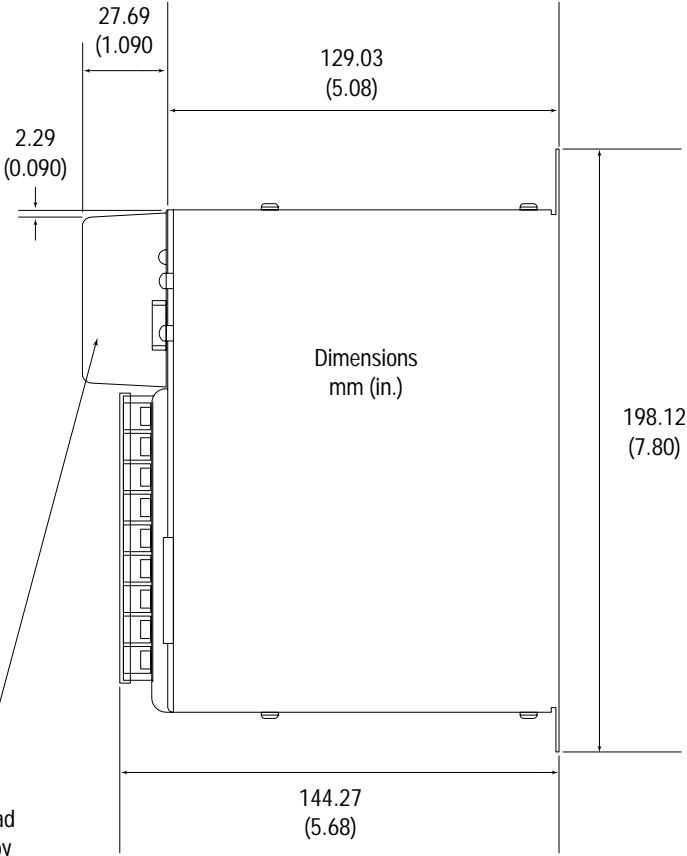
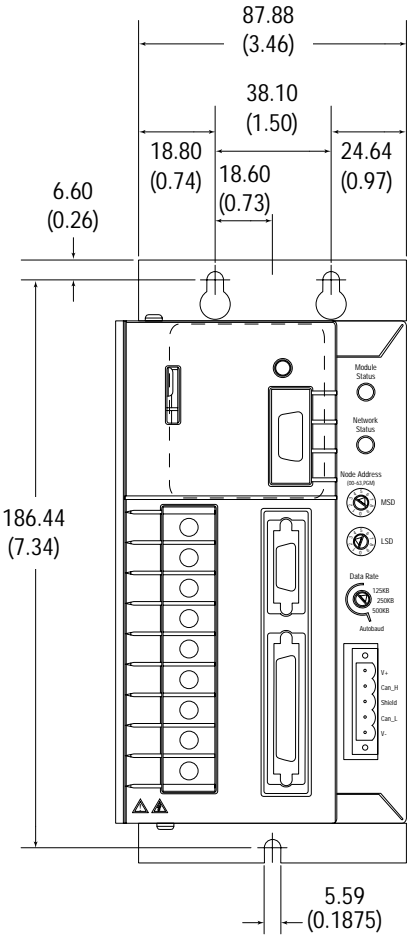

TouchPad Assembly

- NOTES:
1. Allow 76.2 mm (3.00 in.) clearance in front of unit for cables.
 2. Allow 12.7 mm (0.50 in.) on both sides of unit.

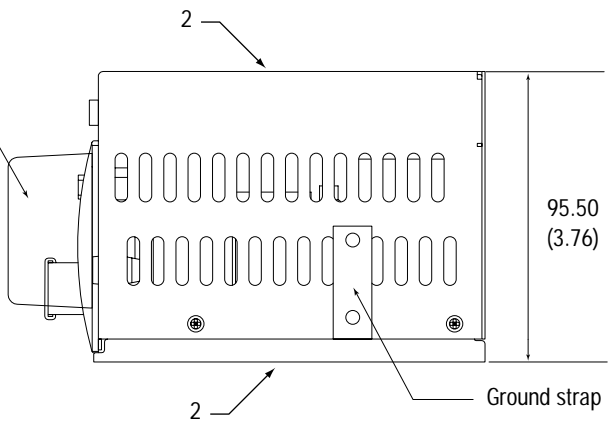

Dimensions for 1398-DDM-009, -009X, -019, and -019X

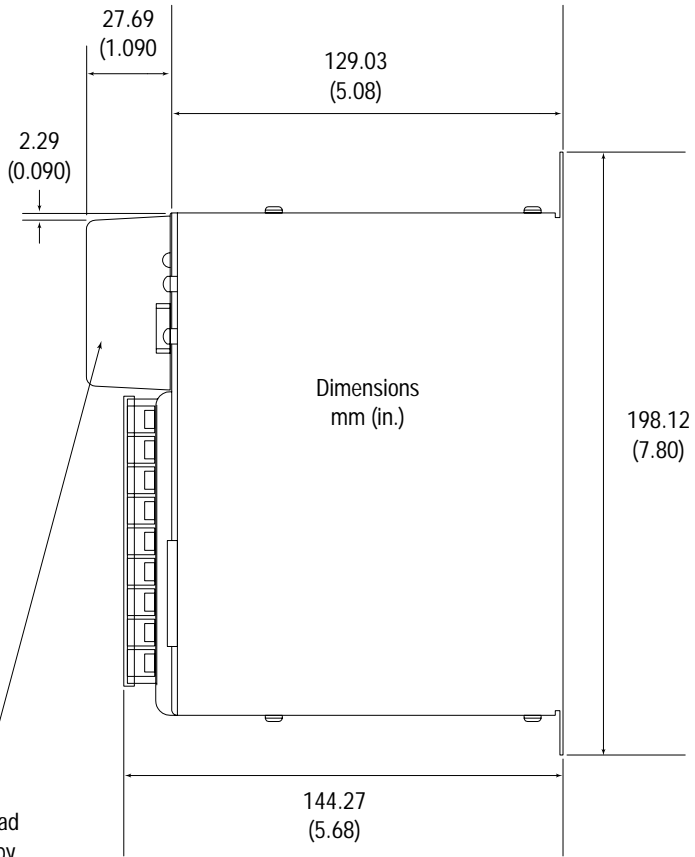
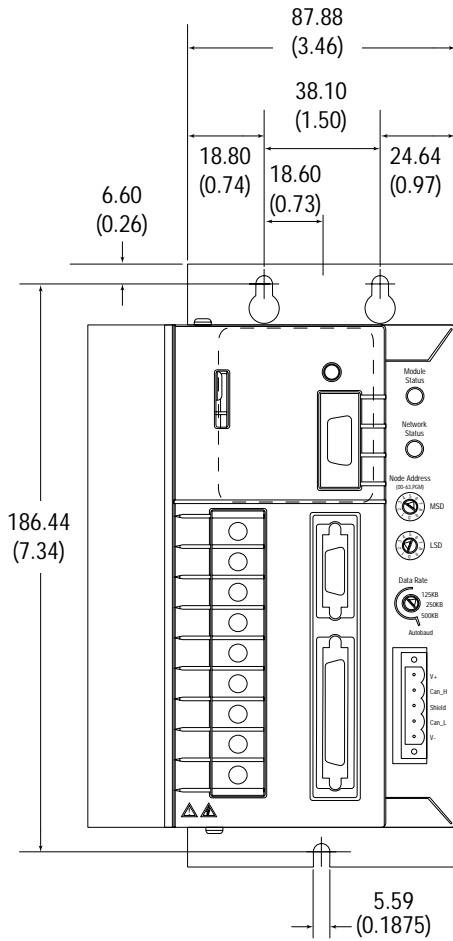

TouchPad Assembly

NOTES:

1. Allow 76.2 mm (3.00 in.) clearance in front of unit for cables.
2. Allow 12.7 mm (0.50 in.) on both sides of unit.

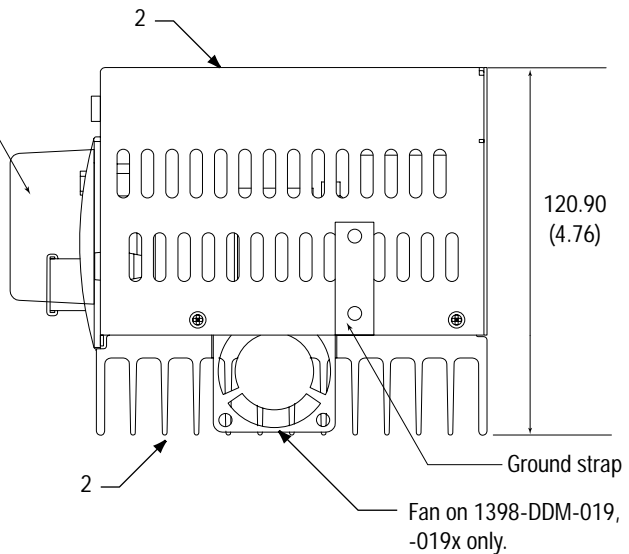

Dimensions for 1398-DDM-009-DN, -009X-DN, -019-DN, and -019X-DN (Ultra 100 with DeviceNet)

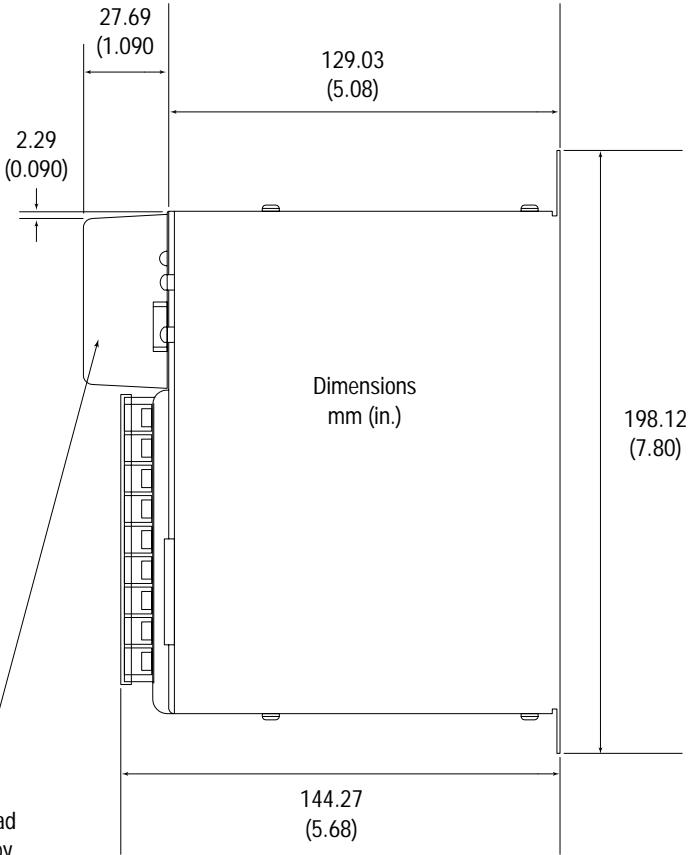
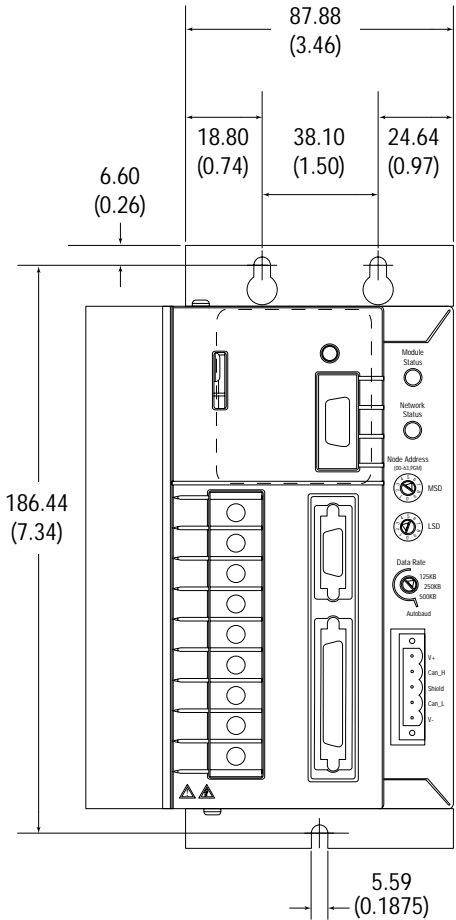

TouchPad Assembly

NOTES:

- 1. Allow 76.2 mm (3.00 in.) clearance in front of unit for cables.
- 2. Allow 12.7 mm (0.50 in.) on both sides of unit.

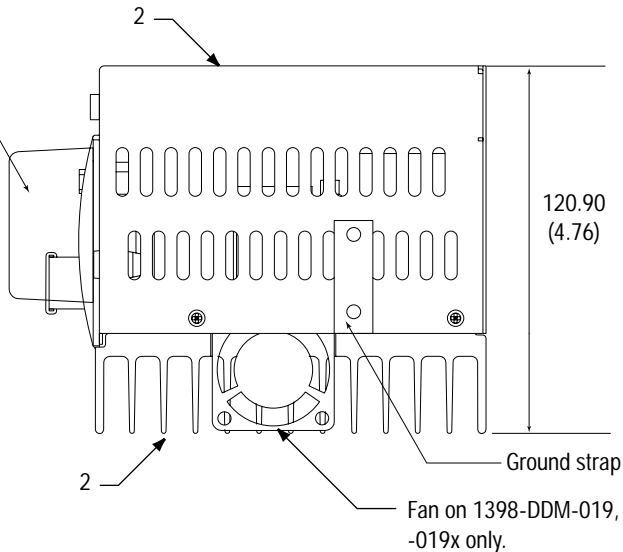

Dimensions for 1398-DDM-010, -010X, -020, -020X, -030, and -030X

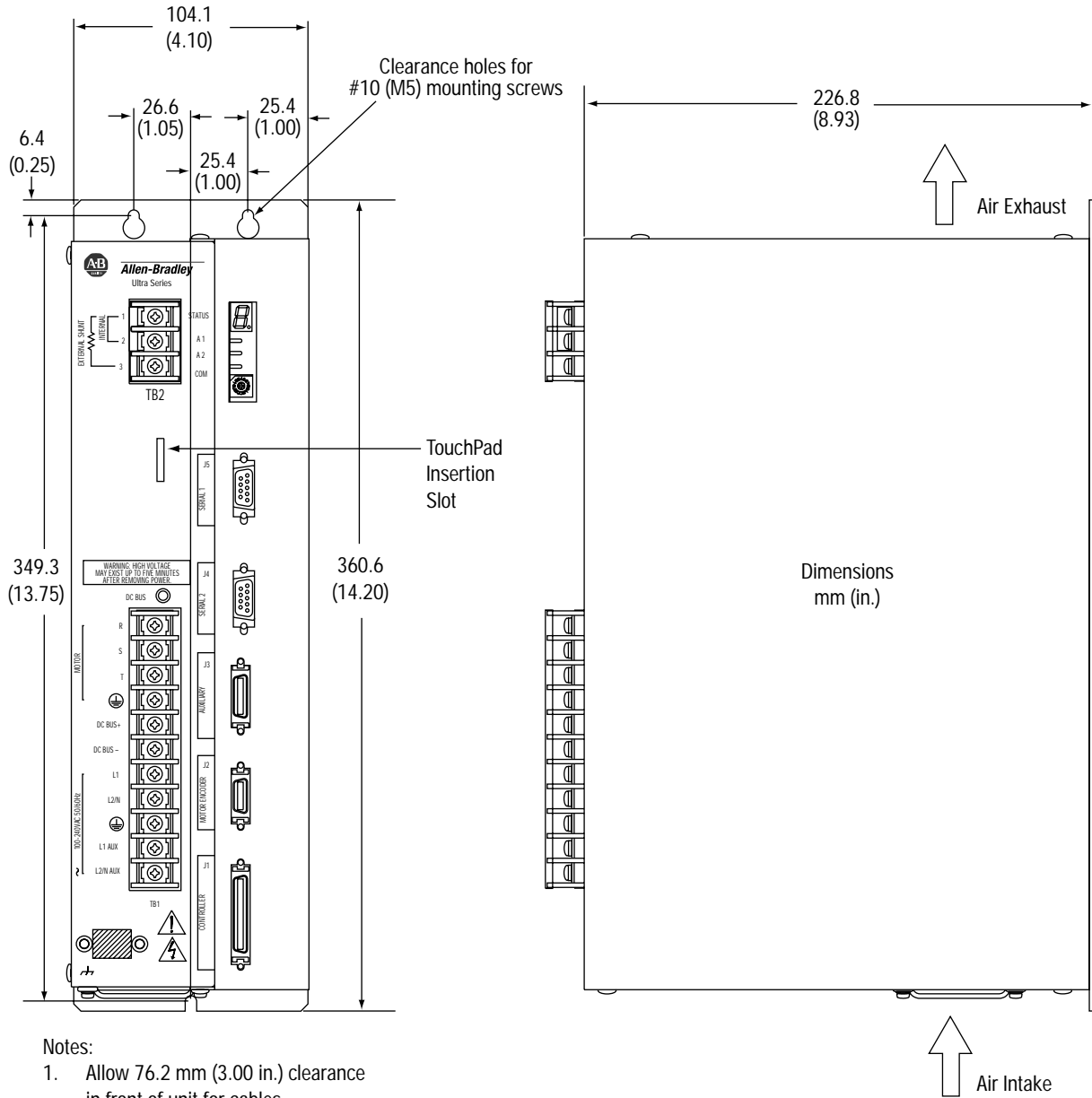

Notes:

1. Allow 76.2 mm (3.00 in.) clearance in front of unit for cables.
2. Allow 12.7 mm (0.50 in.) on both sides of the unit.

Dimensions for 1398-DDM-075 and -075X

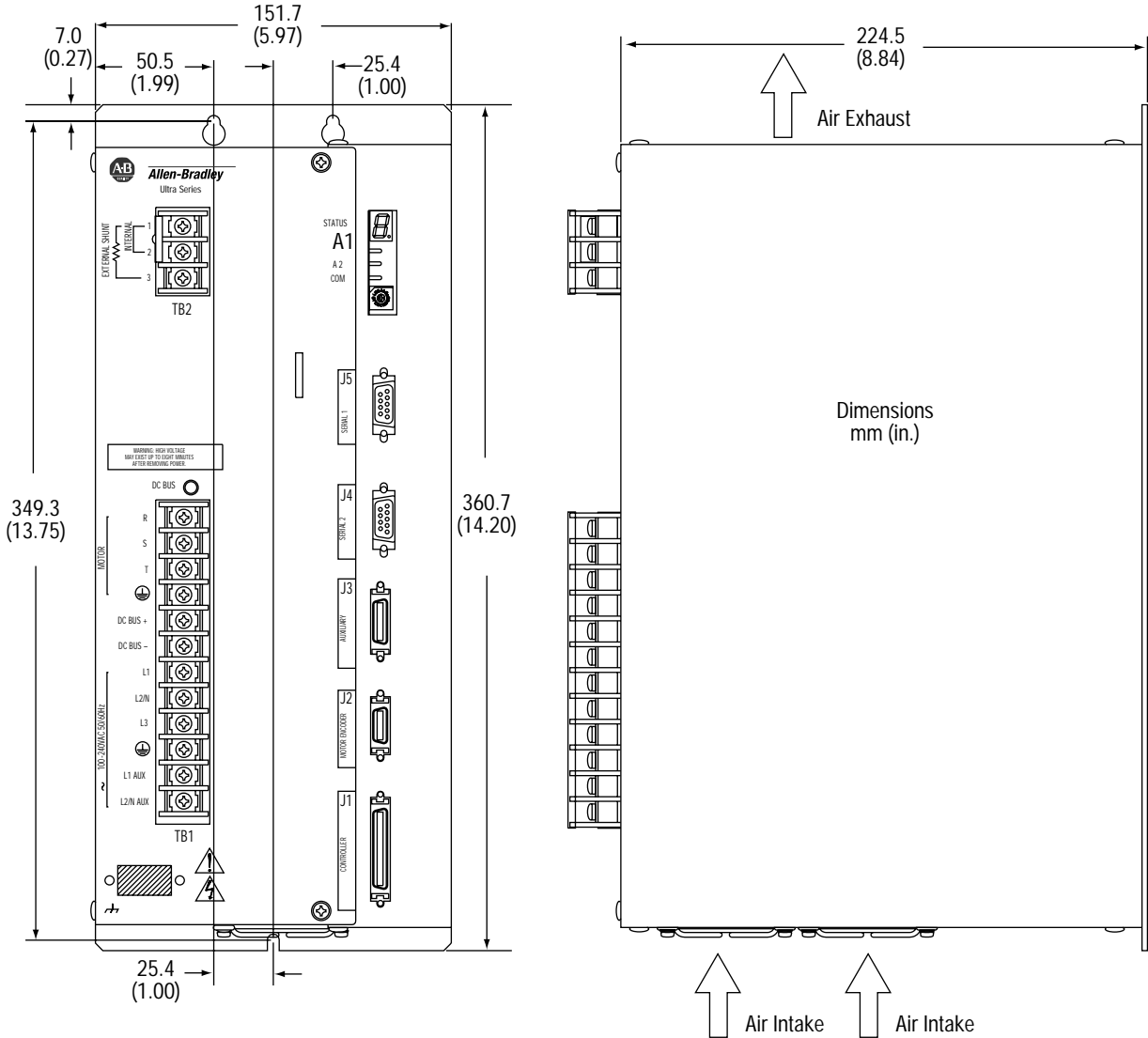

Notes:

1. Allow 76.2 mm (3.00 in.) clearance in front of unit for cables.
2. Allow 12.7 mm (0.50 in.) on both sides of the unit.

Dimensions for 1398-DDM-150 and -150X

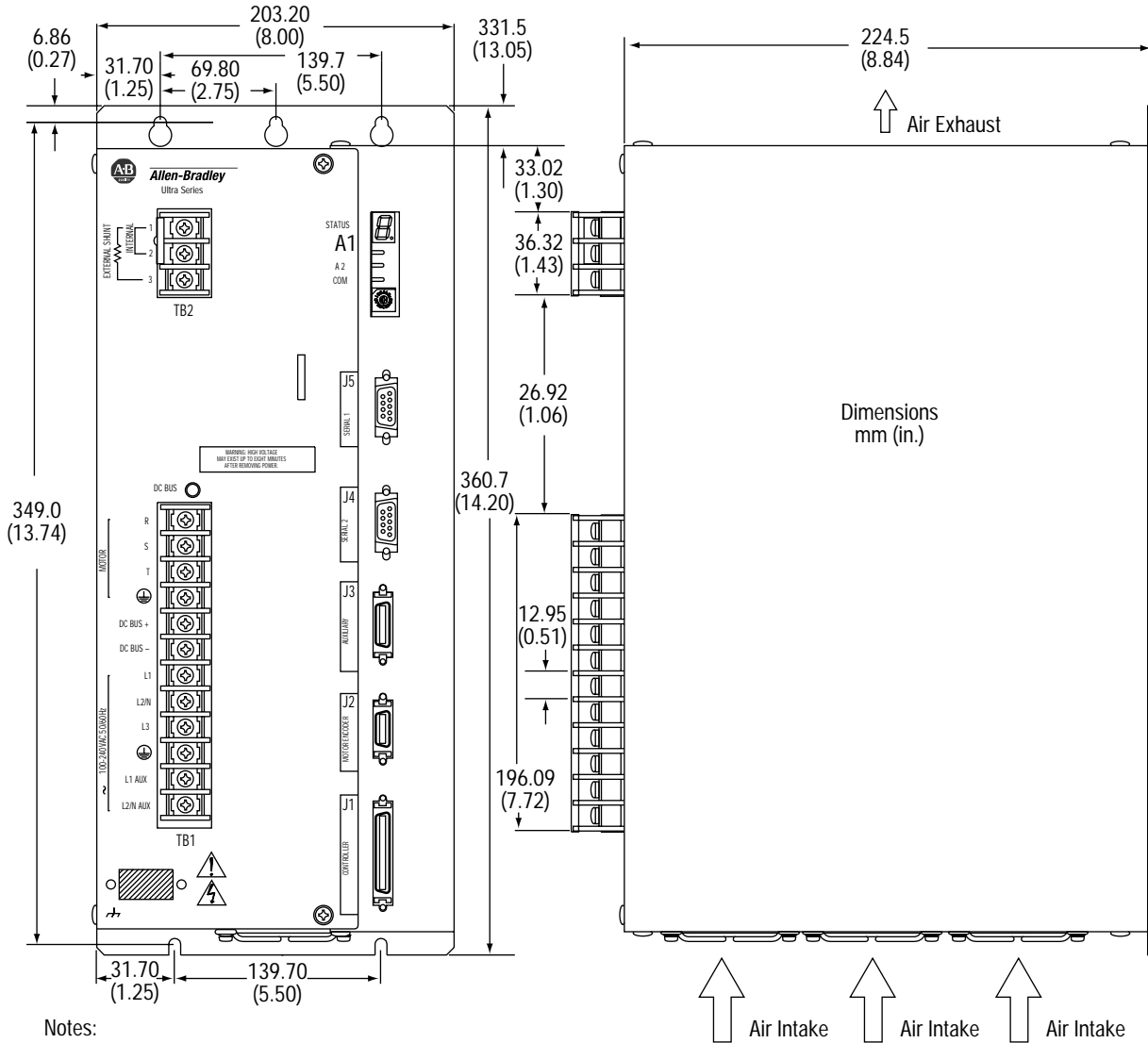

Notes:

1. Allow 76.2 mm (3.00 in.) clearance in front of unit for cables.
2. Allow 12.7 mm (0.50 in.) on both sides of the unit.

ULTRA 100/200 Drives Options and Accessories



Ultra Master

Ultra Master is a point-and-click interface for customizing the ULTRA 100/200 drives to meet the requirements of your application. Suitable for any PC with Windows, Ultra Master allows you to configure, monitor, and troubleshoot a servo system. The online help and quick start-up windows will simplify your setup while tools, such as the on-screen digital oscilloscope, provide simplified tuning and diagnosis. Ultra Master also provides a full array of on-screen meters and other software tools for rapid debugging and measurement. It also keeps error messages in its own non-volatile message buffer to save time in tracking down a problem. In systems with multiple drives, Ultra Master can simultaneously display status and configuration screens for all drives that are on a four-wire RS-485 link. Ultra Master can also be used offline to configure a drive and save the setup to a disk for later downloading to a drive.

PC Requirements

The minimum PC configuration required for Ultra Master software is:

- A 386-based IBM compatible PC with 2MB of available hard disk space to load Ultra Master
- 4 MB minimum of memory
- Microsoft® Windows version 3.1 or higher
- A 3.5 in., 1.44 MB floppy disk drive
- An RS-232 serial port
- A VGA monitor

DeviceNet Option

ULTRA 100 with DeviceNet gives you the ability to operate your drive remotely over a network. DeviceNet, an open, low-cost network based on Controller Area Network (CAN) technology, is a device-level network that can connect individual components, such as drives and switches. ULTRA 100 with DeviceNet supports generic object mapping and unconnected message manager (UCMM) for dynamic and multiple explicit message connections.

Host Mode

The ULTRA 100/200 drives host command protocol provides optional drive configuration using the drive serial communications interface. This powerful feature allows your controller to access all of the drive digital controls using sequences of ASCII characters. The protocol includes error checking to ensure the integrity of the transmitted commands.

In installations that have multiple axes, up to 32 ULTRA 100/200 drives can be addressed by a host computer. These drives communicate with the host computer using a four-wire RS-485 serial interface. The host command protocol includes specific drive addressing, which allows the host to communicate with all the connected drives concurrently.

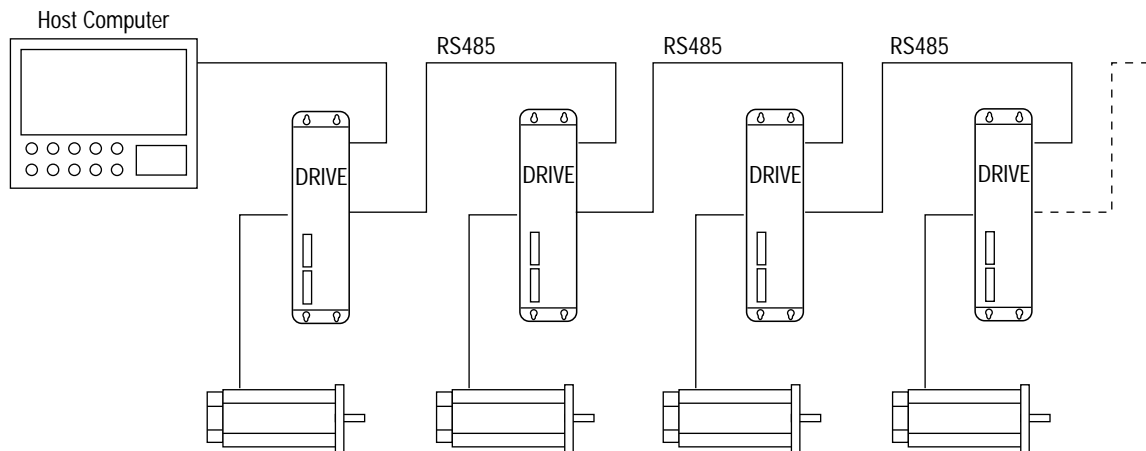

Ultra Master Windows

Ultra Master has a complete set of easy-to-understand windows available from its pull-down menus. The following is a description of some of these windows:

Window	Description
Drive	The Drive window is the main window for performing functions in the Ultra Master. It is a feature-rich and functionally-easy method to visually setup, run, evaluate, and diagnose one or more servo systems. Icon buttons are arranged by function: setup and control, displays, and diagnostics.
Drive Setup	The Drive Setup window appears automatically when Ultra Master is connected to an uninitialized drive. Usually the only parameter that you need to select is the catalog number of the motor that the drive is connected to. The dialog box allows easy access to drive type, motor model, operation modes, drive name, communications, and encoder setup.
Drive Parameters	The Drive Parameters window accesses common operating parameters for the drive including current limits and fault thresholds. This window, along with the I/O Configuration window, defines the necessary drive parameters for your application. The Drive Parameters window allows easy selection of command source, drive modes, and limits.
I/O Configuration	The I/O Configuration window assigns functions to digital inputs and outputs and routes signals to analog outputs. The active and inactive brake delays are also set using this screen. I/O assignments are quickly set up by name.
Tuning	For quick setups, Ultra Master has one-button autotuning. For critical tuning requirements, a built-in function generator allows manual adjustment of the velocity and position gain loops.
Oscilloscope	The digital oscilloscope provides online monitoring of any drive parameter. Its functions include positive and negative triggering, continuous tracing, A vs. B display, and independent channel scaling and offset. Note: The digital oscilloscope should be used as a reference only. It is not intended to replace an oscilloscope for true diagnostic situations.
Diagnostics	The Diagnostics screens provide fast verification of various I/O conditions and allow you to check functions and machine wiring by exercising the digital outputs. A fault history provides complete information on past conditions, and a fault check screen provides instant status on any error conditions.

AC Line Filters

AC line filters are required for EMC compliance.

Part Number	Description	ULTRA 100/200
9101-1516	6A, 1 ϕ	1398-DDM-005
9101-1517	10A, 1 ϕ	1398-DDM-009, -010
9101-1518	23A, 1 ϕ	1398-DDM-019, -020
9101-1575	50A, 3 ϕ	1398-DDM-150
9101-1387	36A, 1 ϕ	1398-DDM-030
9101-1388	50A, 1 ϕ	For multiple drives on one filter ¹
9101-1389	36A, 3 ϕ	1398-DDM-075
9101-1390	70A, 3 ϕ	For multiple 1398-DDM-075 drives on one filter ¹

¹ For multiple drives using one filter, the combined drive input currents must not exceed filter current rating.

AC Line Filter (9101-1516) for 1398-DDM-005

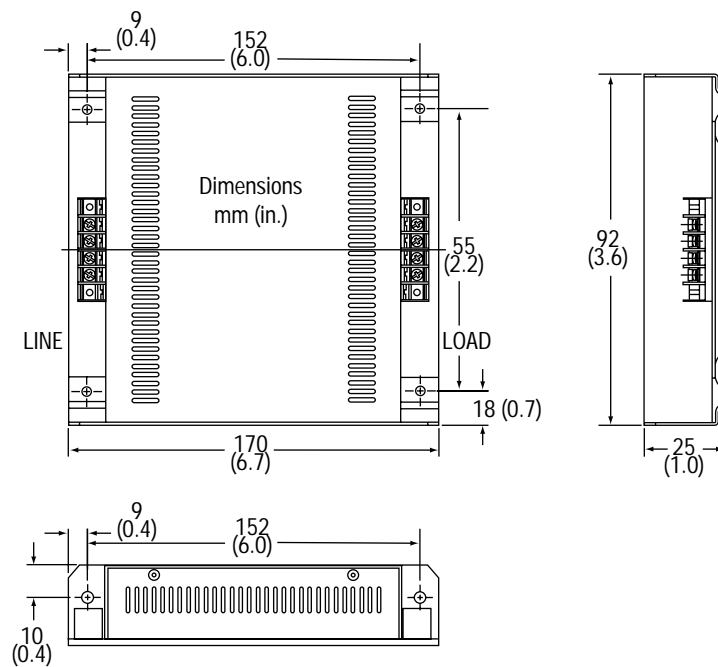

AC Line Filter (9101-1517)
for 1398-DDM-009, 1398-DDM-010, and 1398-PDM-10 10A 1 ϕ

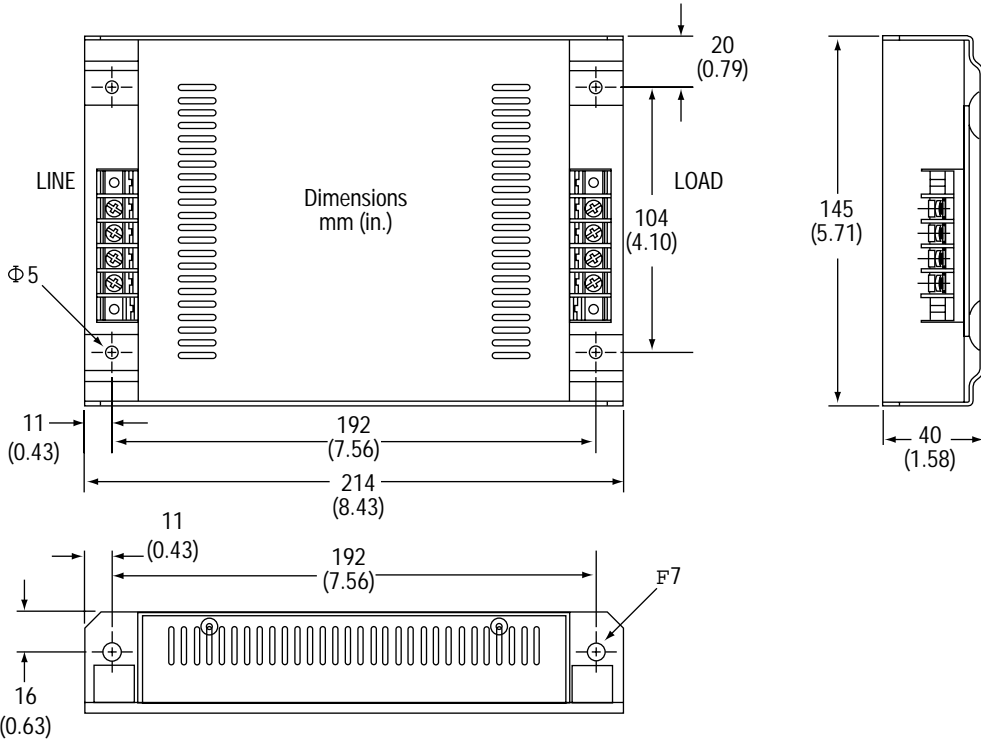

AC Line Filter (9101-1518)
for 1398-DDM-019, 1398-DDM-020, and 1398-PDM-20 23A 1 ϕ

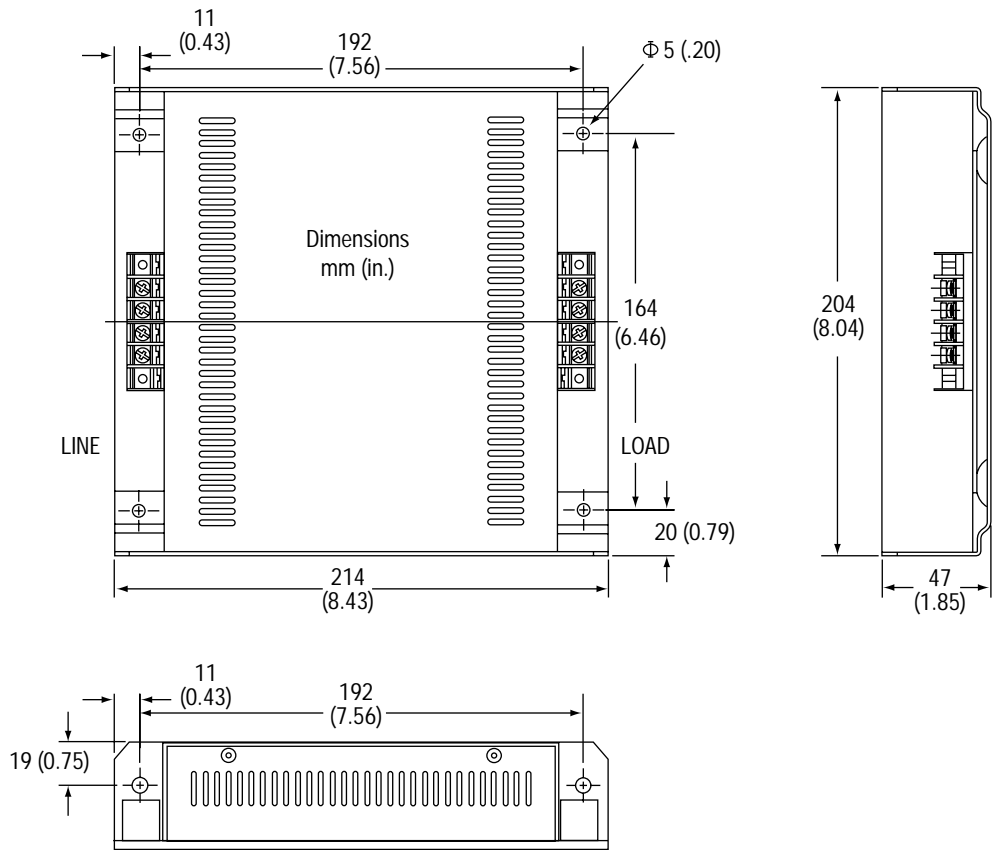

AC Line Filter (9101-1575) for 1398-DDM-150 50A 3 ϕ

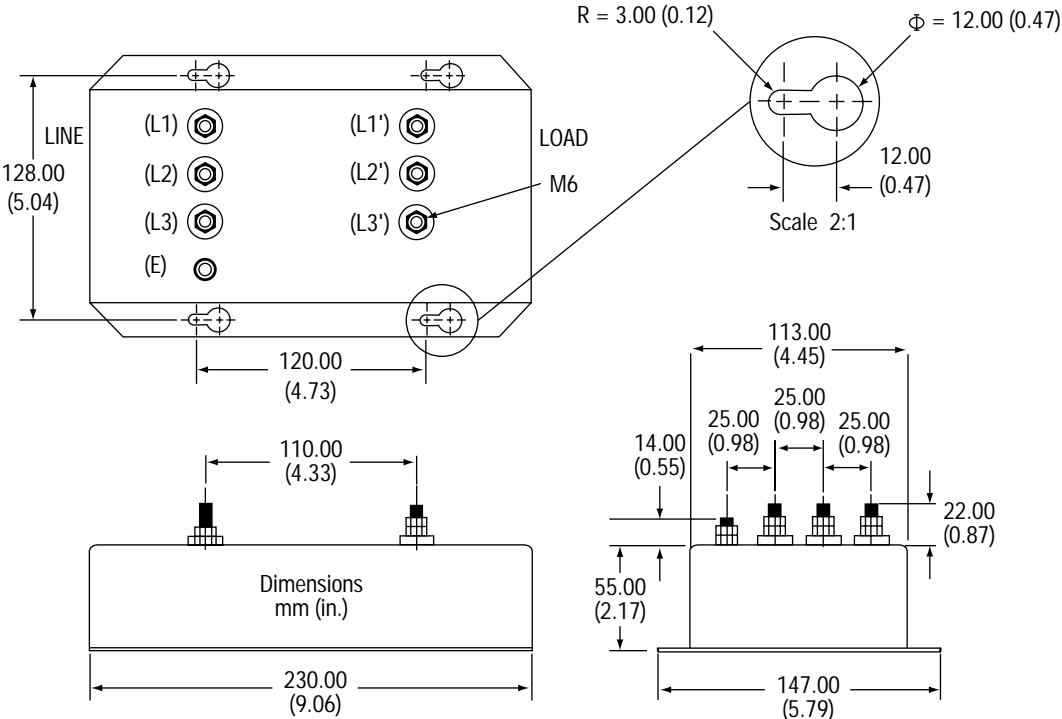

**AC Line Filter (9101-1387)
for 1398-DDM-030 and 1398-PDM-30 36A 1 ϕ**

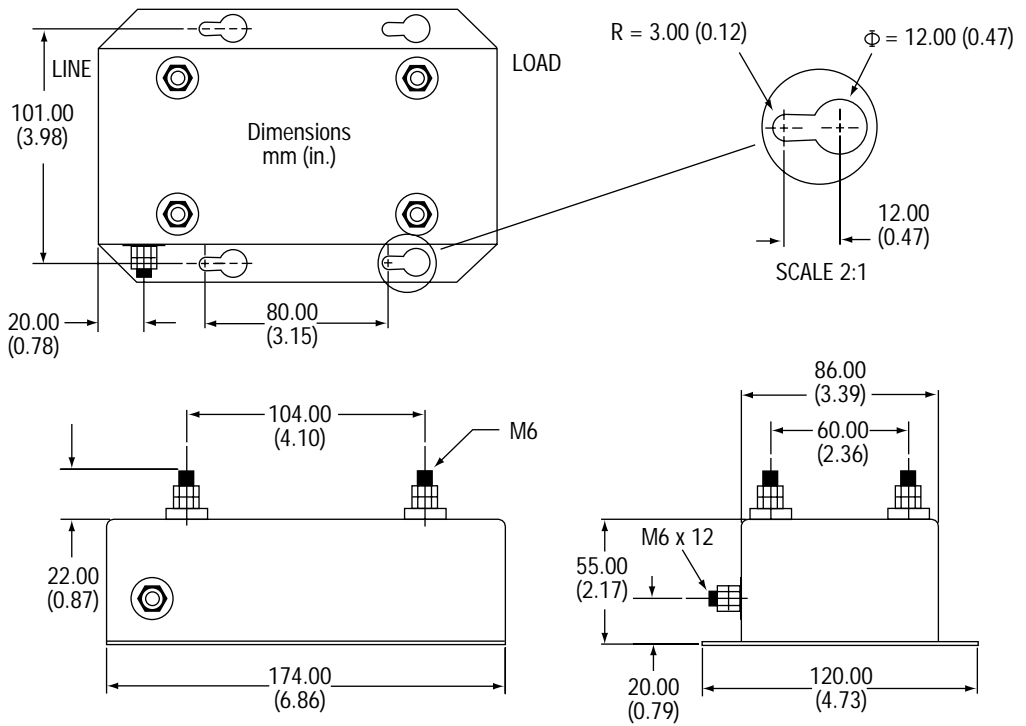

AC Line Filter (9101-1388) for Multiple Drives 50A 1 ϕ

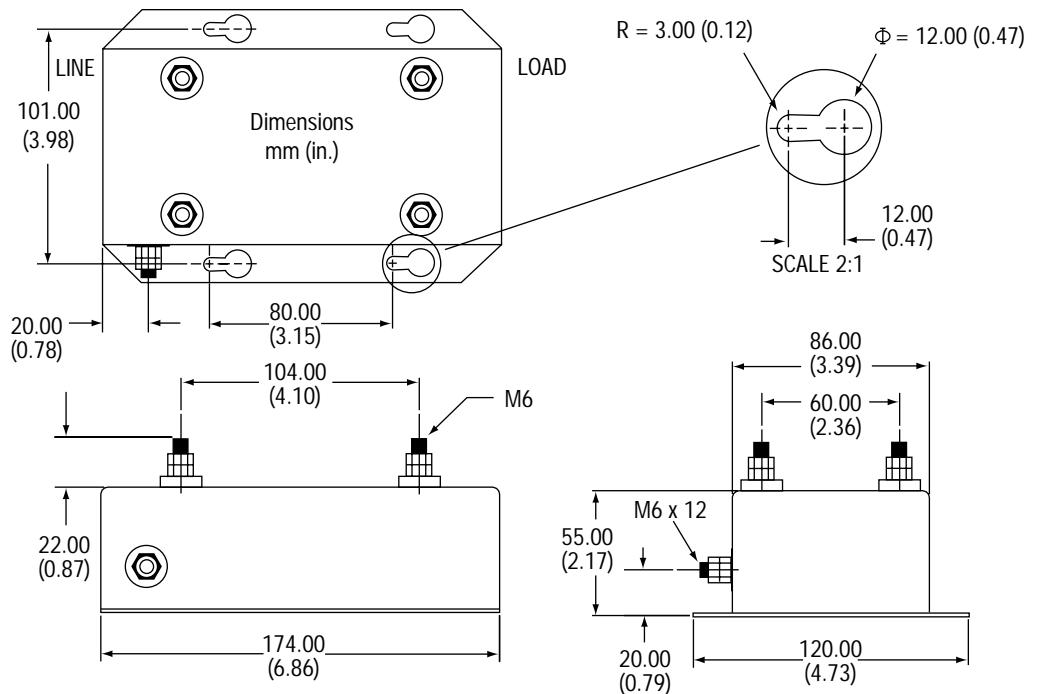

**AC Line Filter (9101-1389)
for 1398-DDM-075 and 1398-PDM-75 3A 3φ**

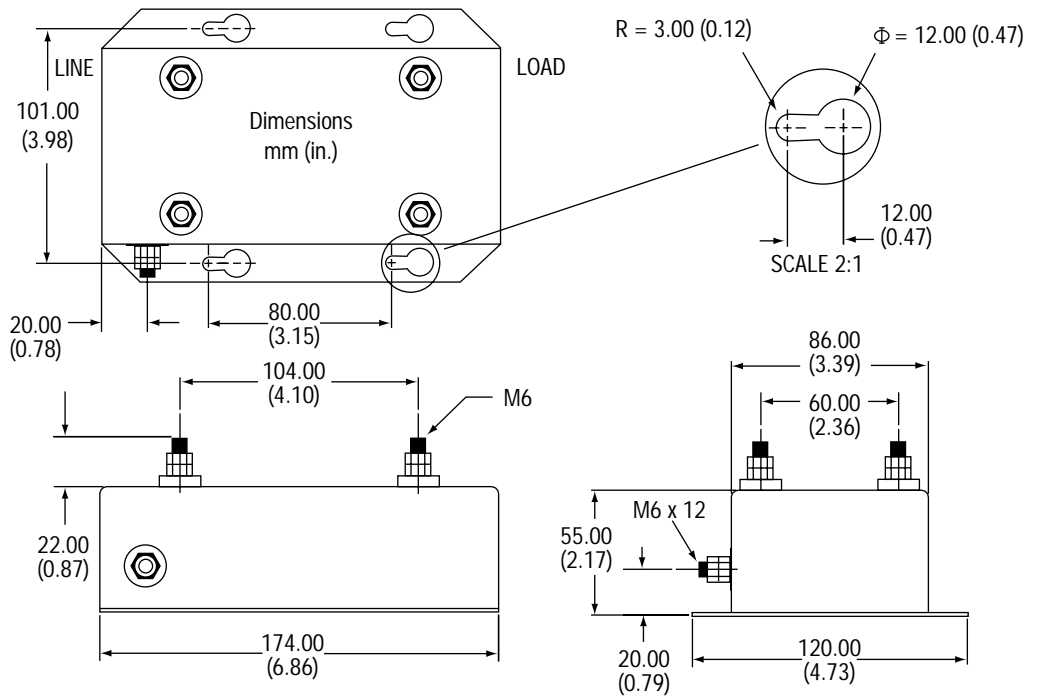

AC Line Filter (9101-1390) for Multiple Drives 80A 3φ

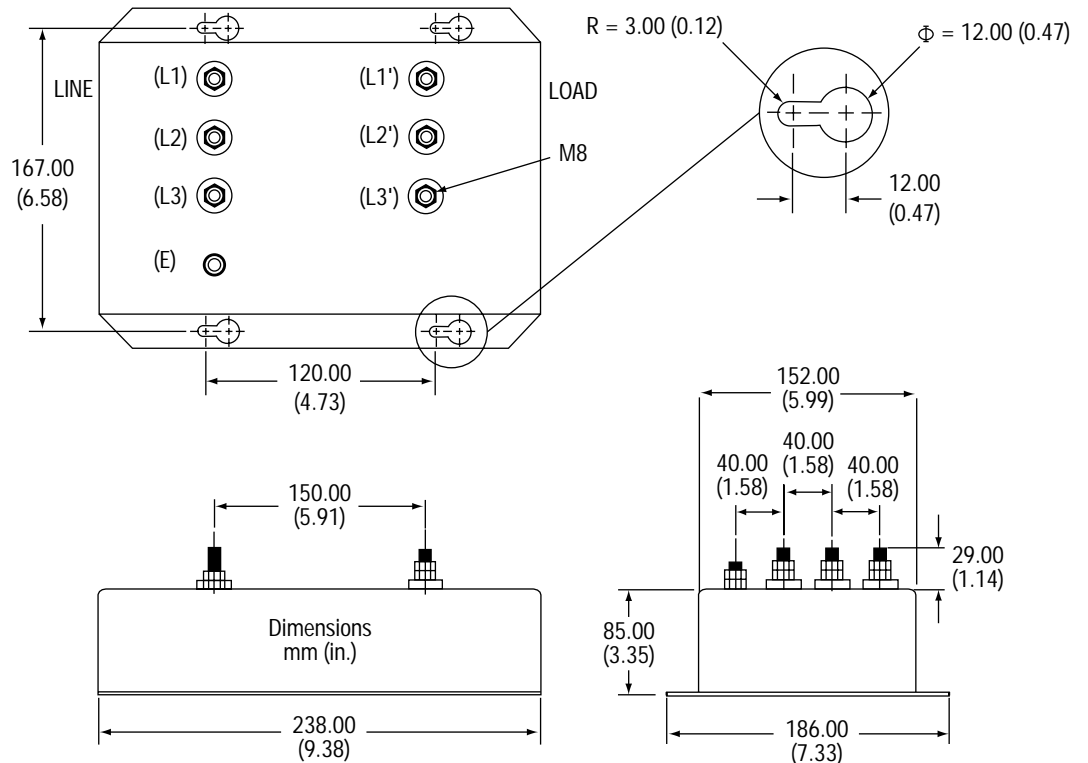

AC Line Filter (9101-1575) for 1398-DDM-150 50A 3 ϕ

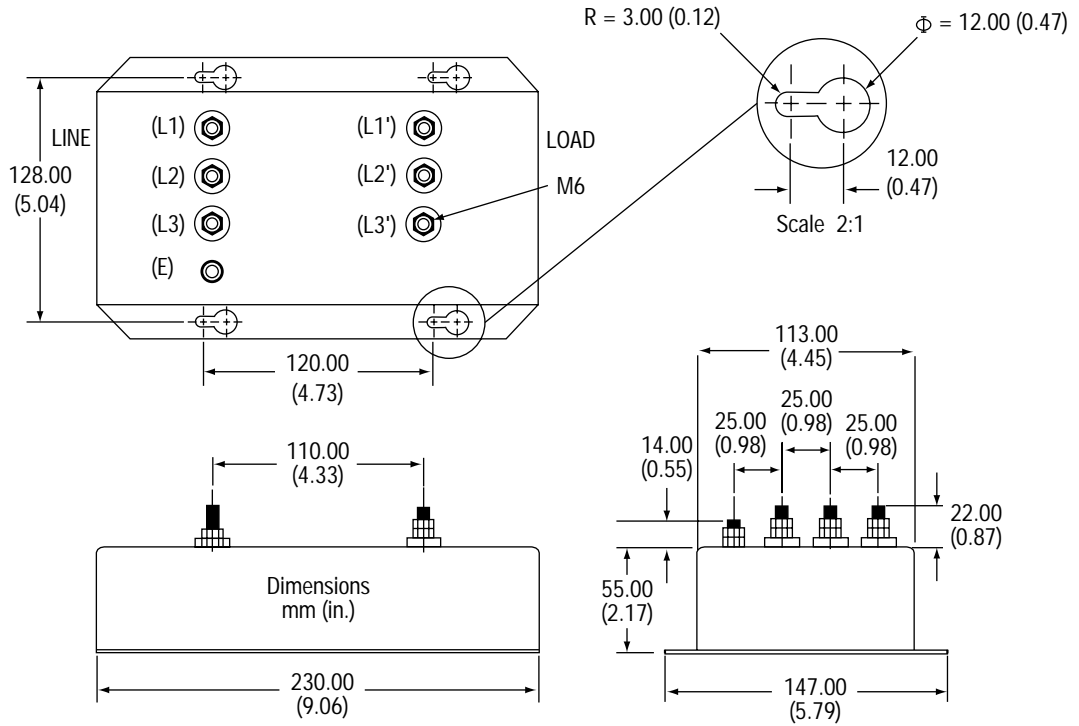

**External Shunt Resistor Kit (9101-1183)
for 1398-DDM-010, -020, -030 and 1398-PDM-10, -20, -30**

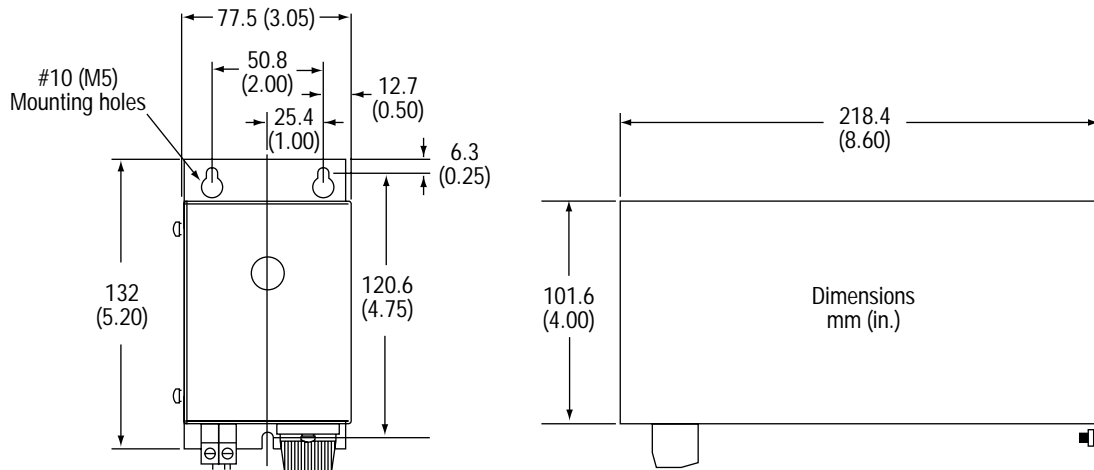

Passive External Shunt Module (1398-SR9P) for 1398-DDM-075, 1398-DDM-150, and 1398-PDM-075

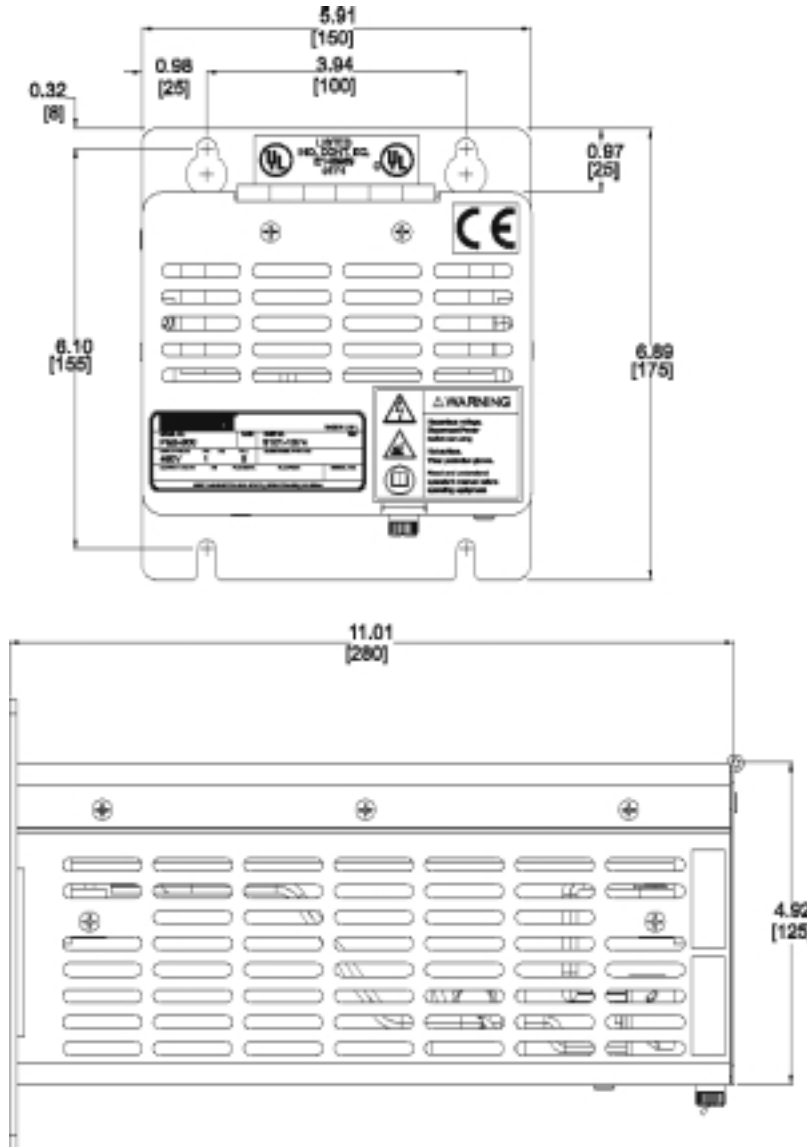

**Active External Shunt Module (1398-SR3AF) for
1398-DDM-005, -005-DN, -005X, -005X-DN
1398-DDM-009, -009-DN, -009X, -009X-DN, and
1398-DDM-019, -019-DN, -019X, -019X-DN**

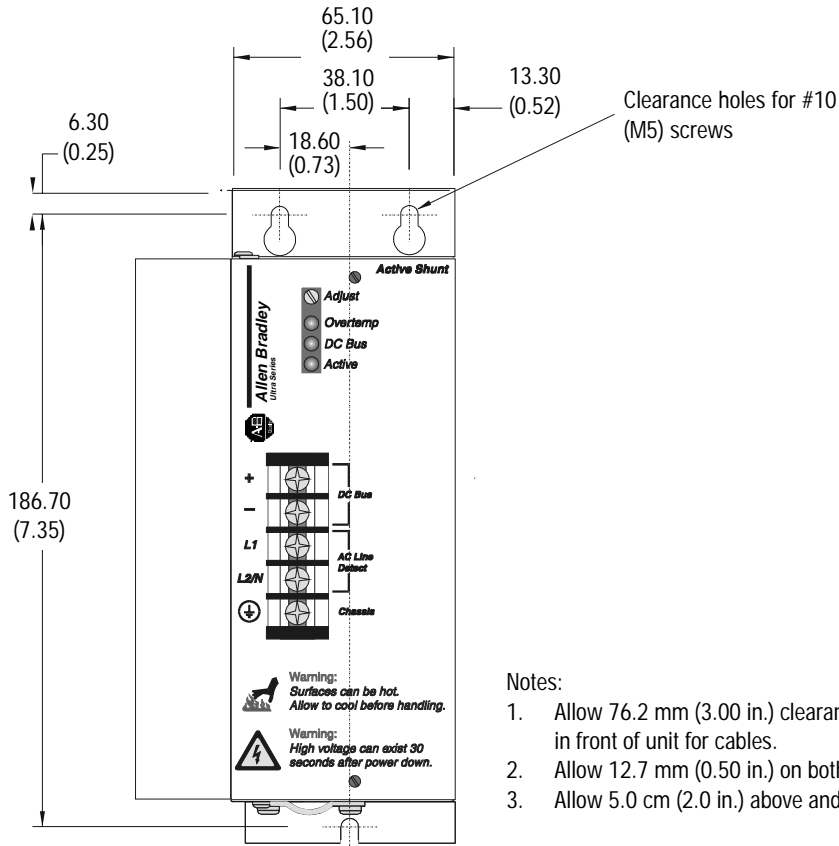

Notes:

1. Allow 76.2 mm (3.00 in.) clearance in front of unit for cables.
2. Allow 12.7 mm (0.50 in.) on both sides of the unit.
3. Allow 5.0 cm (2.0 in.) above and below the unit.

Breakout Board (J1) for ULTRA 100/200 Drives (9101-1391)

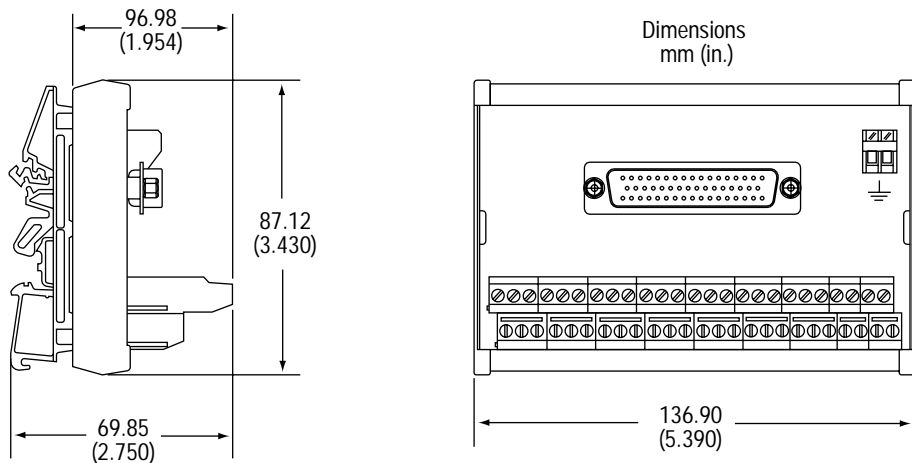

Breakout Board (J2) for ULTRA 100/200 Drives (9101-1392)

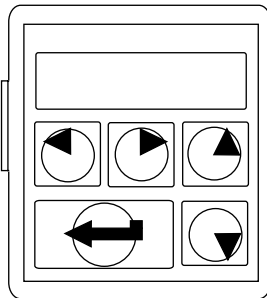
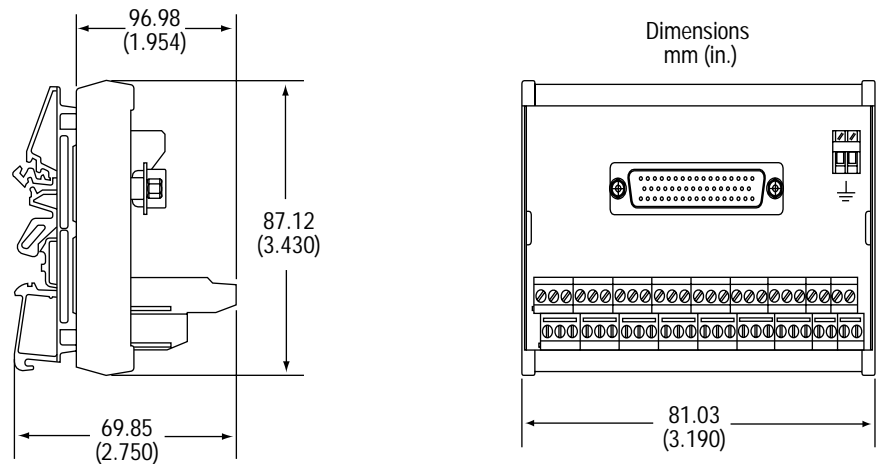

TouchPad

The TouchPad (part number 1398-HMI-001) is a convenient alternative to using Ultra Master for drive setup and monitoring. The small TouchPad module plugs directly into the front of the drive, and its eight-character dot matrix display and five keys provide access to many of the same functions available in Ultra Master software.

The TouchPad is a convenient diagnostic and monitoring tool for use on the factory floor. One TouchPad can support several drives because it is independent of the drive and can be quickly attached and removed once power is removed.

You can enter commands by pressing a single key or combinations of keys. Two modes of operation are available:

- Display mode, which allows you to move through the TouchPad command tree to each parameter.
- Modify mode, which allows you to monitor and change each parameter.

You can modify or view most parameters while the drive is either running or disabled. Refer to the TouchPad Card (publication 1398-5.5) for more information.

TouchPad (1398-HMI-001)

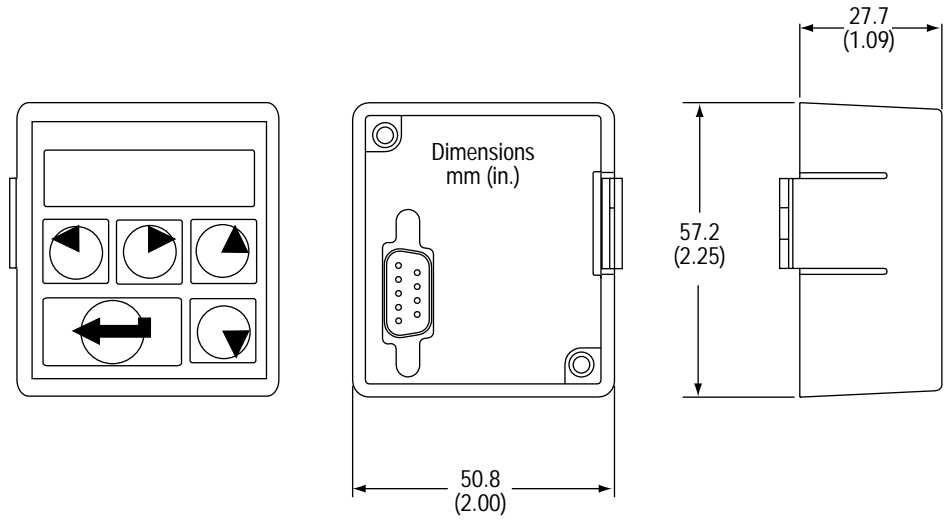

ULTRA Plus Positioning Drives

The ULTRA Plus drive is an integrated, high-performance positioner and brushless drive all in one module. GML Ultra, the Microsoft Windows user interface for ULTRA Plus drives, provides a familiar graphical programming environment and user interface for any size drive.

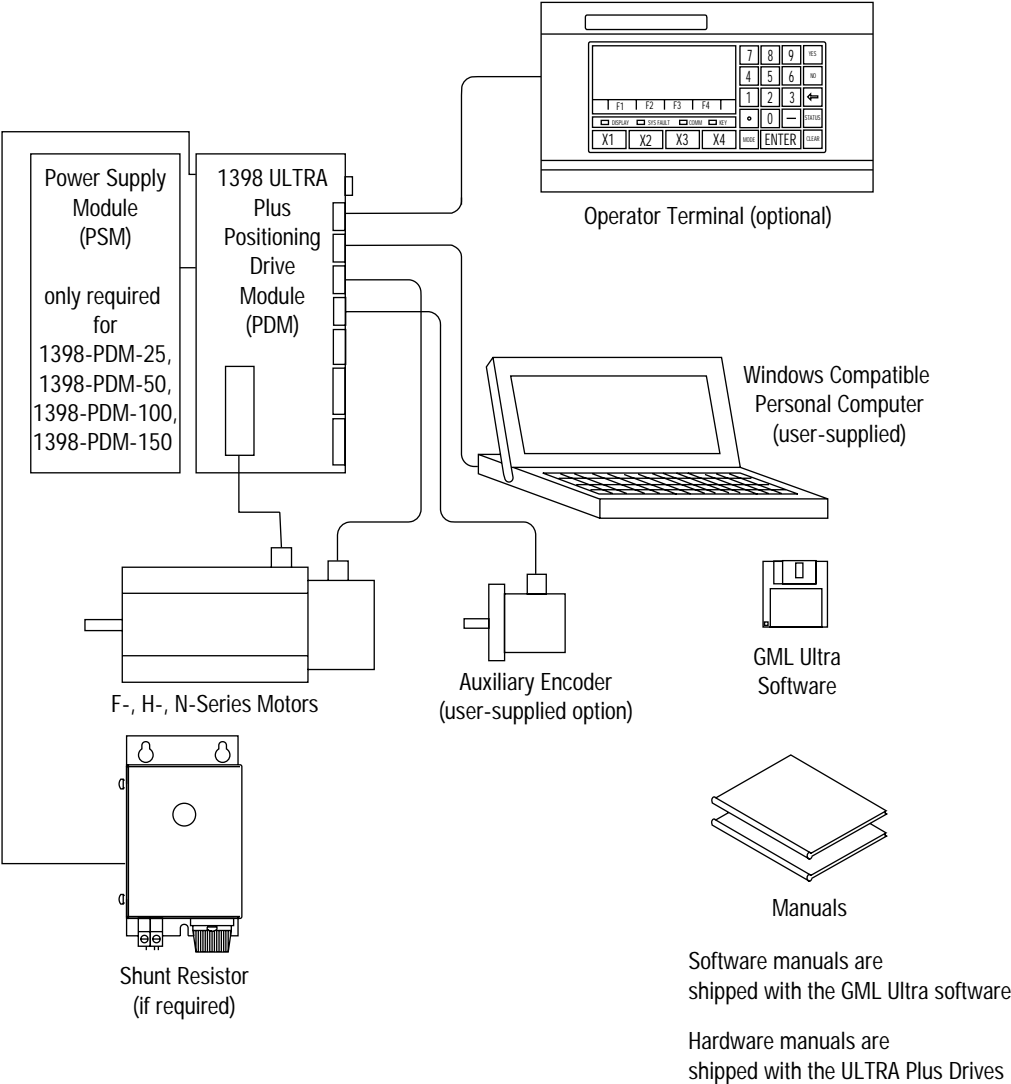

ULTRA Plus Features

Features and benefits of the ULTRA Plus Series motors include:

Features	Benefits
High performance	<ul style="list-style-type: none"> • Brushless sinusoidal commutation • Innovative on-the-fly motion profile generator • High performance master/follower operation • Analog and digital I/O with scan functions • Four-function math and logic functions • Hardware-latched high-speed input
Simple to install	<ul style="list-style-type: none"> • Modular packaging • 115-240V offline operation • No external transformer required (USA)¹ • Built-in shunt regulator • Integral 24V DC opto-isolated I/O • Fits in a 30 cm (12 in.) deep NEMA enclosure
Quick and easy start-up	<ul style="list-style-type: none"> • Intuitive Microsoft Windows user interface • Automatic velocity and position loop tuning • User-friendly GML Ultra programming language • No potentiometer adjustments • Menu-driven user configuration stored in transferable personality module • Offline editing and compiling of programs
Built-in flexibility	<ul style="list-style-type: none"> • Volatile and nonvolatile variables for speed, distance, time, and loop counters • Multiple application programs stored in 32K transferable memory • S-curve, trapezoidal, and complex motion profiles • True feed rate override • Electronic gearing-follower capability • Step and direction inputs
Comprehensive protection and diagnostics	<ul style="list-style-type: none"> • Fault history • Built-in solid state soft start • Motor and drive system thermally protected • Phase loss indication (1398-PDM-25, -50, -100, and -150 only) • UL listed
Superior operator terminal	<ul style="list-style-type: none"> • Bright, easy-to-read 4x20 vacuum fluorescent display • Easy user setup for customizing applications • Up to ten ULTRA Plus systems can be addressed from one operator terminal • Smart display of user messages and variable entry • Real-time axis status monitoring

¹ Isolation transformers may be required for ULTRA Plus drives 1398-PDM-25, -50, -100, and -150.

ULTRA Plus General Specifications

The following tables contain ULTRA Plus general specifications:

Control Hardware

Specification	Description
Microprocessor	80C196KC
Clock	20 MHz
Hardware watchdog	0.016 seconds
Firmware memory	96K with 8K text EPROM
Program memory	32K in the personality module
Motor feedback	Incremental encoder
Encoder input frequency	750 kHz
Pulse and direction input	800 kHz maximum pulse input frequency
Analog I/O	One 12-bit DAC output One 8-bit DAC programmable monitor output One 10-bit ADC input
Digital I/O	16 general purpose inputs (user-definable) Inputs can be used as: <ul style="list-style-type: none"> • Enable • Home command • Jog FWD • Pause • REV limit • FWD limit • Home switch • Jog REV • Return • Start 8 general purpose outputs (user-definable) Outputs can be used as: <ul style="list-style-type: none"> • At home • Home sequence complete • Program running • Error • In position 2 dedicated normally open relays <ul style="list-style-type: none"> • PDM enabled • PDM ready

Resolutions, Ranges, Accuracy, and Speeds

Specification	Description
Position: Range Repeatability	32 bits ($\pm 2,147,483,648$ encoder counts) ± 1 encoder count
Velocity command: Range Resolution	4,294,967,296:1 0.000229 RPM (2000-line encoder)
Acceleration: Range Resolution Type	4,294,967,296:1 0.00381 rev/s/s (2000-line encoder) Linear or S-curve
Electronic gearing	32767:1 to 1:32767 (+/-)
Registration input	2 (35 μ s \pm 15 μ s)
Latched input	1.5 μ s maximum (Encoder 1 or Encoder 2)

Serial I/O

Specification	Description
Serial ports	2 (or 1 with daisy chain)
Type	RS-232C/RS-422
Baud rate	1,200 to 19,200
Multi-drop	Up to 63 addresses

Tuning and Compensation

Specification	Description
Position loop: KP KP2 PZone KFF KI IZone	Proportional gain Proportional gain when within PZone KPZ active zone Velocity feed forward gain Integral gain KI active zone
Velocity loop: PGain IGain FGain Filter	Proportional gain Integral gain Acceleration feed forward gain Filters undesirable high frequency
Auto-tune application	Six levels, adjustable
Manual tuning: Command generator	Real-time adjustments

ULTRA Plus Specifications

The following tables contain ULTRA Plus specifications for the 1398-PDM-10, -20, -30, and -75 motors.

General

Specification	1398-PDM-			
	10	20	30	75 (3 ϕ)
Peak output current/phase	10A	20A	30A	75A
Continuous output current/phase	5A	10A	15A	35A
Continuous output power	1 kW	2 kW	3 kW	7.0 kW
RMS line voltage input (50/60 Hz, single phase) ¹	115-240V AC nominal			
Internal continuous shunt power dissipation	50W (200W with external resistor option)			50W
Internal peak shunt power	4.5 kW (6.0 kW with external resistor option)			10.0 kW
Operating temperature	0°C to 50°C (32°F to 122°F)			
Storage/shipping temperature	-40°C to 80°C (-40°F to 176°F)			
Relative humidity	5 to 95% non-condensing			
Weight	5 kg (11 lb)			10 kg (21 lb)

¹ Speed-torque curves represent 230V AC input. Reduced voltage will reduce speed.

ULTRA Plus External Shunt Resistor for 1398-PDM-10, -20, and -30 (9101-1183)

Specification	Description
Continuous shunt power dissipation	200W
Peak shunt power	6000W

ULTRA Plus Specifications Specific to 1398-PDM-25, -50, -100, and -150

The following tables contain ULTRA Plus specifications for the 1398-PDM-25, -50, -100, and -150 motors.

General

Specification	1398-PDM-			
	25	50	100	150
Peak output current/phase	25A	50A	100A	150A
Continuous output current/phase	20A	40A	50A	65A
Continuous output power	4 kW	8 kW	10 kW	12 kW
Operating temperature	0°C to 50°C (32°F to 122°F)			
Storage/shipping temperature	-40°C to 80°C (-40°F to 176°F)			
Relative humidity	5 to 95% non-condensing			
Weight	11.0 kg (24.2 lb)			

Power Supply Modules

Specification	1398-PSM-50	1398-PSM-125
RMS line voltage (three-phase 50/60 Hz VAC)	115-240V AC nominal	
Output bus voltage minimum	325V DC	
Continuous output current	50A	100A
Continuous shunt power dissipation	600W	1200W
Peak shunt power	20 kW	40 kW
Operating temperature	0°C to 50°C (32°F to 122°F)	
Storage shipping temperature	-40°C to 80°C (-40°F to 176°F)	
Relative humidity	5 to 95% non-condensing	
Weight	11.9 kg (26.2 lb)	

Operator Terminal

Specification	Description
Input power	110/240V AC 15% single phase or 24V AC/DC option available
Operating temperature	0°C to 55°C (-32°F to 131°F)
Storage/shipping temperature	-40°C to 70°C (-40°F to 158°F)
Relative humidity	5 to 95% non-condensing
Weight	3 kg (7 lb)
Front panel seal	Water tight, dust tight

Block Diagram of the ULTRA Plus Positioning Module

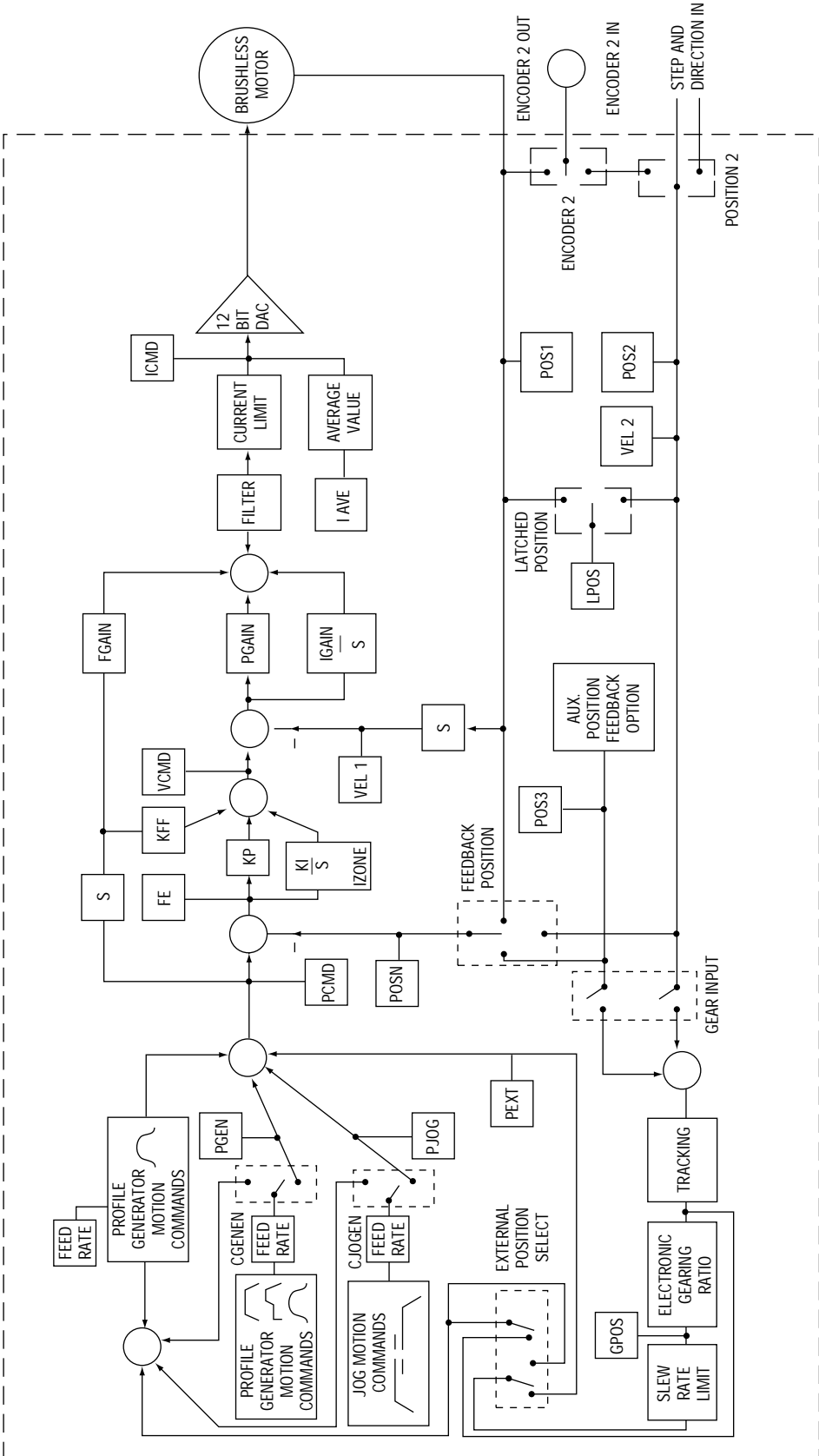

Ultra Plus Interconnect Diagram

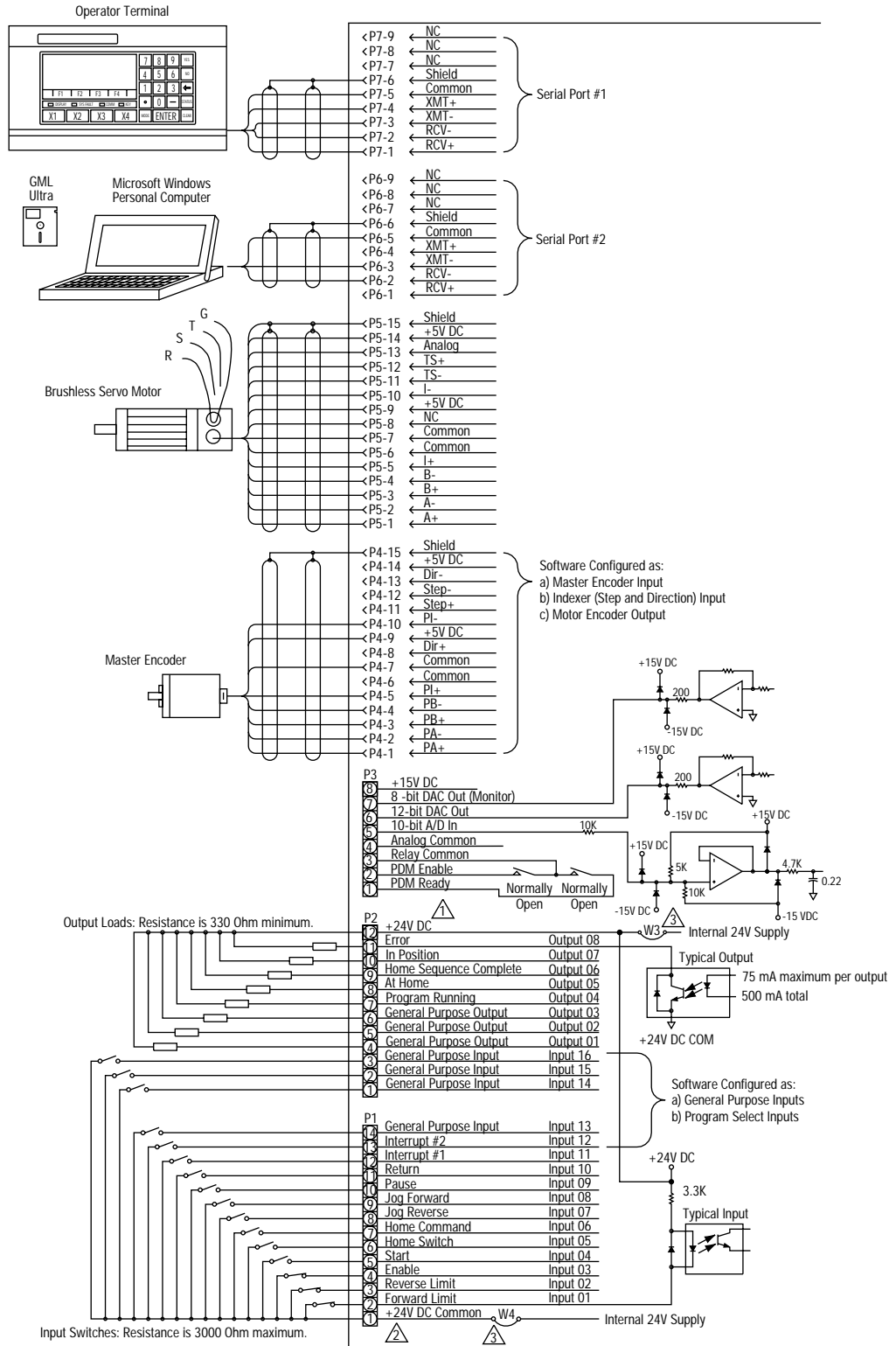

System Configuration Checklist

Use the following checklist to configure an ULTRA Plus system for your application:

ULTRA Plus Drives¹ (choose one of the following):

- | | |
|--------------------------------------|---------------------------------------|
| <input type="checkbox"/> 1398-PDM-10 | <input type="checkbox"/> 1398-PDM-25 |
| <input type="checkbox"/> 1398-PDM-20 | <input type="checkbox"/> 1398-PDM-50 |
| <input type="checkbox"/> 1398-PDM-30 | <input type="checkbox"/> 1398-PDM-100 |
| <input type="checkbox"/> 1398-PDM-75 | <input type="checkbox"/> 1398-PDM-150 |

¹ Includes the *ULTRA Plus Installation Manual* (Publication 1398-5.1).

Power Supply Modules

(choose one of the following if you are using 1398-PDM-25, -50, -100, or -150):

- | |
|---------------------------------------|
| <input type="checkbox"/> 1398-PSM-50 |
| <input type="checkbox"/> 1398-PSM-125 |

Note: You can use up to six ULTRA Plus drives with a single power supply. See page 64 for PSM module selection guidelines.

ULTRA Series Motors (choose one of the following):

- | F-Series Motors | H-Series Motors | N-Series Motors |
|---|---|---|
| <input type="checkbox"/> F-4030-Q-H00AA | <input type="checkbox"/> H-2005-K-H00AA | <input type="checkbox"/> N-3406-2-H00AA |
| <input type="checkbox"/> F-4050-Q-H00AA | <input type="checkbox"/> H-3007-N-H00AA | <input type="checkbox"/> N-3412-2-H00AA |
| <input type="checkbox"/> F-4075-R-H00AA | <input type="checkbox"/> H-3016-N-H00AA | <input type="checkbox"/> N-4214-2-H00AA |
| <input type="checkbox"/> F-6100-R-H00AA | <input type="checkbox"/> H-4030-M-H00AA | <input type="checkbox"/> N-4220-2-H00AA |
| <input type="checkbox"/> F-6200-R-H00AA | <input type="checkbox"/> H-4030-P-H00AA | <input type="checkbox"/> N-5630-2-H00AA |
| <input type="checkbox"/> F-6300-R-H00AA | <input type="checkbox"/> H-4050-P-H00AA | <input type="checkbox"/> N-5637-2-H00AA |
| | <input type="checkbox"/> H-4075-R-H00AA | <input type="checkbox"/> N-5647-2-H00AA |
| | <input type="checkbox"/> H-6100-Q-H00AA | |
| | <input type="checkbox"/> H-6200-Q-H00AA | |
| | <input type="checkbox"/> H-6300-Q-H00AA | |
| | <input type="checkbox"/> H-8350-S-H00AA | |
| | <input type="checkbox"/> H-8500-S-H00AA | |

Cables

Note: The last three digits select standard cable lengths of: 10 ft (3.0m)—010; 25 ft (7.7m)—025; 50 ft (15.0m)—050; 75 ft (23.0m).

TB1 to Motor Power Connections (choose one of the following):

	Part Number	Description
<input type="checkbox"/>	9101-0250-xxx	Use for 1398-PDM-25, -50, -100, or -150 with H-3000 motors
<input type="checkbox"/>	9101-0251-xxx	Use for 1398-PDM-25, -50, -100, or -150 with H-4000 and F-4000 motors
<input type="checkbox"/>	9101-0252-xxx	Use for 1398-PDM-25, -50, -100, or -150 with H-6000 and F-6000 motors
<input type="checkbox"/>	9101-0253-xxx	Use for 1398-PDM-25, -50, -100, or -150 with H-8000 motors
<input type="checkbox"/>	9101-1080-xxx	Use for 1398-PDM-10, -20, -30, or -75 with H-2000 and H-3000 motors
<input type="checkbox"/>	9101-1081-xxx	Use for 1398-PDM-10, -20, -30, or -75 with H-4000 and F-4000 motors
<input type="checkbox"/>	9101-1381-xxx ¹	Use for H-2000 and H-3000 motors
<input type="checkbox"/>	9101-1382-xxx ¹	Use for F-4000 and H-4000 motors
<input type="checkbox"/>	9101-1383-xxx ¹	Use for F-6000 and H-6000 motors
<input type="checkbox"/>	9101-1399-xxx	Use for 1398-PDM-75, -150 with F-6300 and H-6300 motors
<input type="checkbox"/>	9101-1467-xxx ¹	Use for N-Series motors
<input type="checkbox"/>	9101-2179-xxx	Use for 1398-PDM-10, -20, -30, or -75 with H-6000 and F-6000 motors

¹ Required for EMC compliance. For more information, see *ULTRA Plus Requirements for Compliance with European Directives* section on page 61 of this document.

P4 Connections (choose one of the following):

	Part Number	Description
<input type="checkbox"/>	9101-1474-xxx	P4 to the motor feedback
<input type="checkbox"/>	9101-2031-xxx	P4 to the auxiliary encoder
<input type="checkbox"/>	9101-2127-002	P4 to P4 for master/follower applications

P5 Connections (choose one of the following):

	Part Number	Description
<input type="checkbox"/>	9101-1474-xxx	P5 to the motor feedback
<input type="checkbox"/>	9101-2027-xxx	P5 to motor encoder
<input type="checkbox"/>	9101-2135-025 or 9101-2135-050	P5 to motor encoder (right angle motor connector)

P6 to Personal Computer Connections:

	Part Number	Description
<input type="checkbox"/>	9101-2024-xxx	P6 to personal computer (RS-232)

¹ P6 communication cables should be no longer than 15.0 m (50 ft) for RS-232)

P7 to Operator Terminal Connections:

	Part Number	Description
<input type="checkbox"/>	9101-2025-xxx	P7 to operator terminal

¹ P7 communication cables should be no longer than 15.0 m (50 ft) for RS-232)

Accessories (choose all that apply):

	Part Number	Description
<input type="checkbox"/>	9101-1517 ¹	AC line filter (10A, 1 ϕ) for 1398-PDM-10
<input type="checkbox"/>	9101-1518 ¹	AC line filter (23A, 1 ϕ) for 1398-PDM-20
<input type="checkbox"/>	9101-1387 ¹	AC line filter (36A, 1 ϕ) for 1398-PDM-30
<input type="checkbox"/>	9101-1388 ¹	AC line filter (50A, 1 ϕ) for multiple drives on one filter
<input type="checkbox"/>	9101-1389 ¹	AC line filter (36A, 3 ϕ) for 1398-PDM-75
<input type="checkbox"/>	9101-1390 ¹	AC line filter (80A, 3 ϕ) for multiple drives on one filter
<input type="checkbox"/>	9101-1183	External shunt resistor for 1398-PDM-010, -020, and -030
<input type="checkbox"/>	9103-0152 ¹	24V sourcing I/O conversion card
<input type="checkbox"/>	1398-HMI-002	Operator terminal
<input type="checkbox"/>	GML-D-U	GML Ultra software ²

¹ Required for EMC compliance. For more information, see *ULTRA Plus Requirements for Compliance with European Directives* section on page 61 of this document.

² Includes the *GML Ultra Getting Started Manual* (Publication 1398-5.10), the *GML Ultra User Manual* (Publication 1398-5.11), and the *GML Ultra Reference Manual* (1398-5.12).

Mating Connectors

Cross-reference of mating connectors with P1, P2, and P3 connectors on your drive.

Connector	Type	Poles	Manufacturer	Catalog Number
P1	BL 14	14	Weidmüller	12603.6
P2	BL 12	12	Weidmüller	12601.6
P3	BL 8	8	Weidmüller	12597.6

Dimensions for 1398-PDM-10, -20, and -30

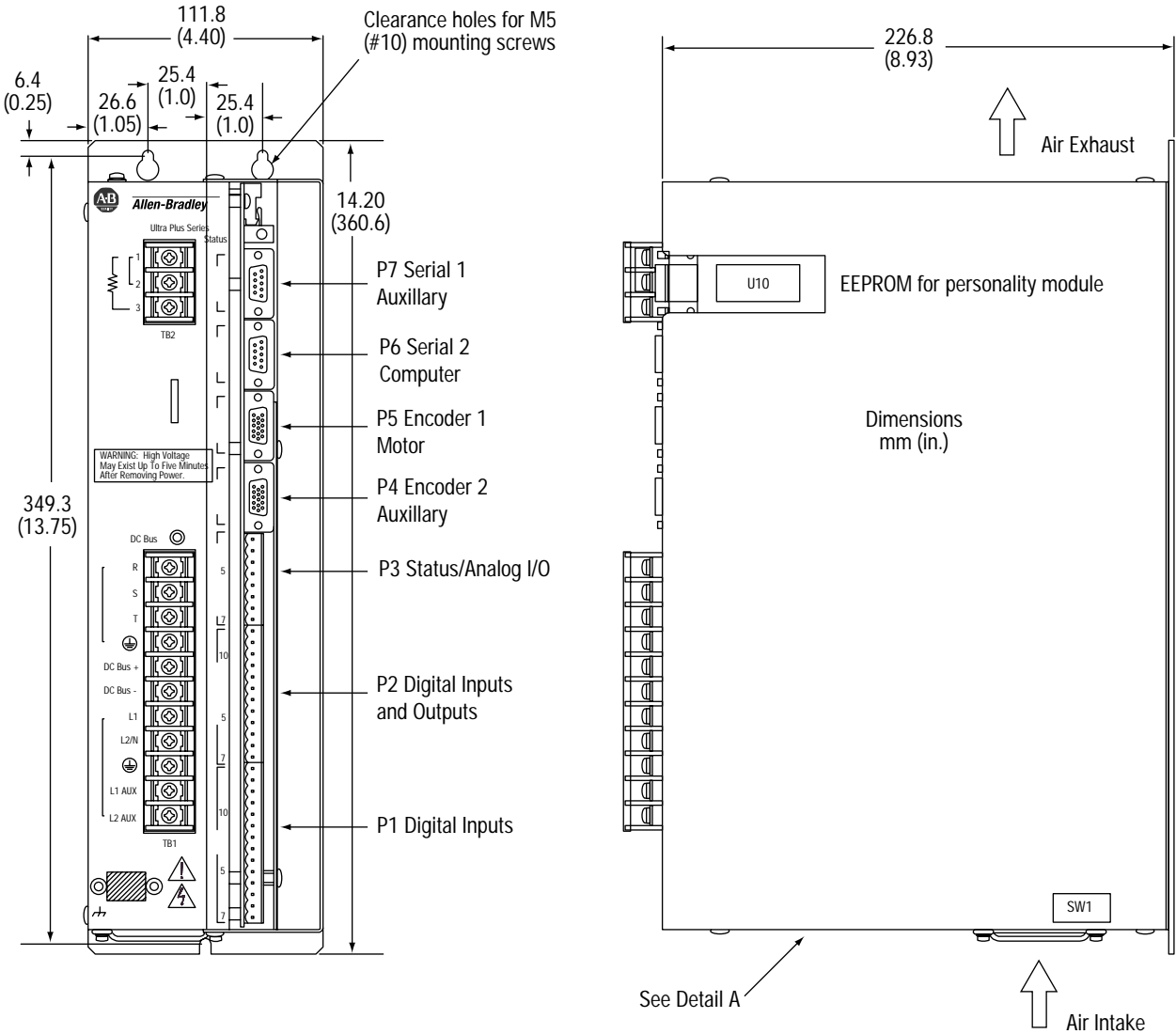

- Notes:
1. Allow 2.00 inches (50.8 mm) above the unit for air flow.
 2. Allow 2.00 inches (50.8 mm) in front of the unit for cable clearance.

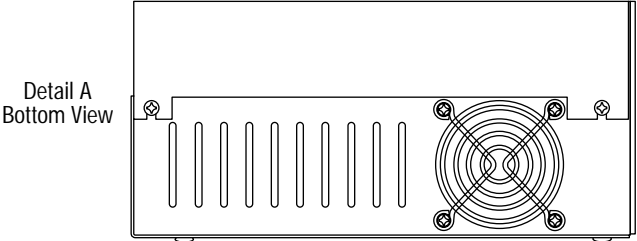

Dimensions for 1398-PDM-75

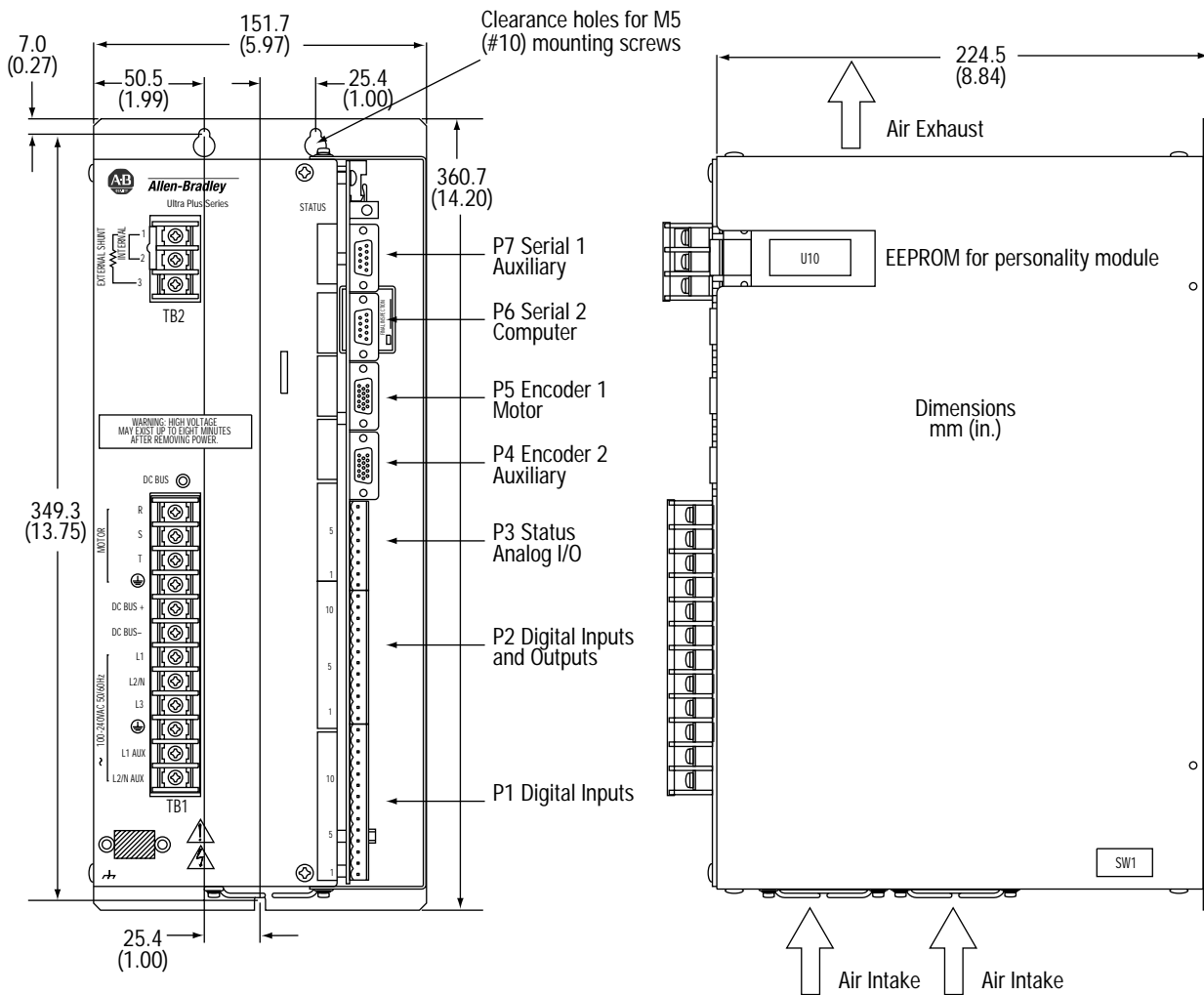

Notes:

1. Allow 2.00 inches (50.8 mm) minimum spacing above and below modules for airflow.
2. Allow 0.5 inches (13 mm) minimum spacing between modules for cover removal and around modules for cable clearance and airflow.
3. Allow 11 inches (280 mm) minimum spacing for cable clearance.

Dimensions for 1398-PDM-25, -50, -100, and -150

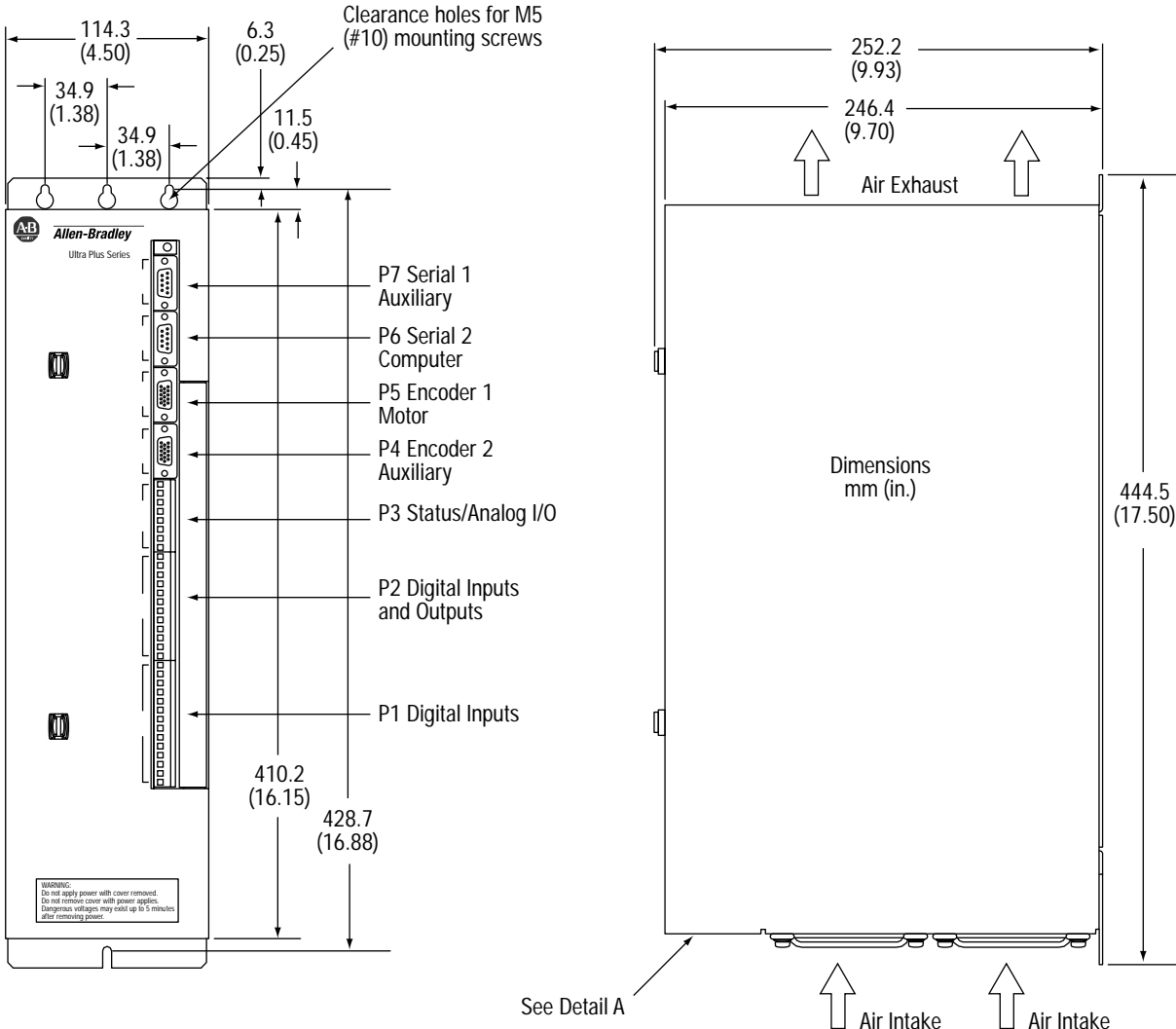

- Notes:
1. Allow 4.0 inches (102 mm) minimum spacing for airflow above and below modules.
 2. Allow 0.5 inches (13 mm) minimum spacing for airflow between modules for cover removal and around modules for cable clearance and airflow.
 3. Allow 11.0 inches (280 mm) minimum spacing for cable clearance.

Note: Power supply modules have identical dimensions and mounting requirements as PDMs.

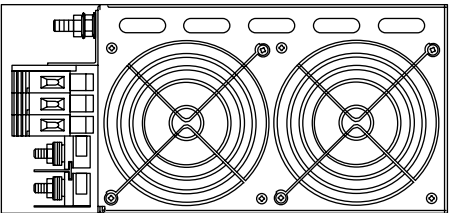

Detail A
Bottom View

ULTRA Plus Drives Options and Accessories

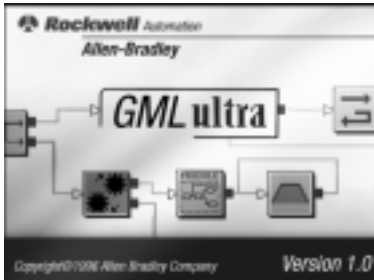

GML Ultra for Windows

GML Ultra software offers a departure from traditional programming. It provides a natural, object-oriented environment. Icons—or picture blocks—represent motion functions. You can create a motion program by piecing together icons that represent your application. You place these icons on the screen in the order required by your application and connect them using a “soldering iron.” To break connections and modify them, you can use a “wire cutter.” You can fill in motion and process details later. The result is a well-documented, easy-to-read, and easy-to-troubleshoot program.

Once you draw your “flow-chart” diagram of the basic logic of the application, you can enter details about each icon using a “fill-in-the-form” approach. Each icon has a form, which you can call up by pointing and clicking on the icon. The “move axis” icon, for example, has choices for the type of move to perform, plus places to enter position, speed, acceleration, and deceleration. You can enter these details at any time, which minimizes the need to consult a manual or to understand a specialized syntax. Online, content-sensitive help is also available to provide immediate understanding of how each icon can be used.

PC Configuration

The minimum PC configuration required for GML Ultra software is:

- A 25 MHz 486-class CPU
- 4 MByte RAM (8+ Mbyte recommended)
- Microsoft Windows 3.1
- MS-DOS 5.0 (6.0 recommended)
- An EGA screen (VGA or Super VGA recommended)
- A Windows compatible mouse and driver
- A 3.5 high density (1.44 Mbyte) diskette drive
- Two serial ports (COM1 and COM2)

GML Ultra Windows

GML Ultra has many features that allow you to quickly program your ULTRA Plus application. The following is a description of some of these features:

Feature	Description
Dialog editor	The GML Ultra Dialog Editor window allows you to quickly assemble standard motion icons into a natural, graphical representation of the application. You can quickly assemble and modify your GML diagram to capture the basic logic of the process without the complexity of a traditional programming language. After you complete the basic diagram, you can easily add required information in a "fill-in-the-form" dialog box exposed by double-clicking on each motion icon.
Configuration and setup windows	The pull-down configuration and setup windows prompt "fill-in-the-form" dialog boxes that allow setup and selection of the control, drive, and I/O parameters from preset default values. Because all adjustments are available through the PC, manual adjustments of the positioning drive module are eliminated.
Tuning	ULTRA Plus provides automatic closed loop gain compensation for velocity and position loops. This unique algorithm provides a refinement to factory default settings in more demanding applications. Multiple choices are offered for different application types.
Application library	GML Ultra provides a library of sample application diagrams and templates that you can quickly and easily modify to reduce programming and commissioning time.
Help screens	GML Ultra provides comprehensive, context-sensitive help screens to provide assistance for on-the-spot programming questions.
Online manager	The Online Manager window allows monitoring and control of real-time tasks and access to GML Ultra diagnostic features like direct commands and watch window. From this window, you can jog an axis, observe selected variables and I/O, monitor feedback, get status information, and much more. Online trace allows you to control and to observe program flow to identify process and program problems.

ULTRA Plus Requirements for Compliance with European Directives

To comply with European directives, your ULTRA Plus system must include the following components:

- A 24V sourcing I/O conversion card
- An AC line filter
- Shielded power cables

For more information about compliance with European Directives for 1398-PDM-10, -20, -30, and -75, refer to the *ULTRA Plus Installation Manual* (Publication 1398-5.1).

24V Sourcing I/O Conversion Card (9103-0152) and Cables

The 24V I/O conversion card converts the 16 internal inputs and 6 internal outputs from an active low state to an active high state. It must be mounted in the same enclosure as the ULTRA Plus. By adding this component, you comply with the European Union Low Voltage Directive (LVD).

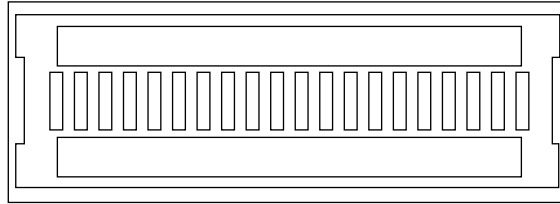

To connect your ULTRA Plus drive to the I/O conversion card, you can use the following optional cables:

- Part number 44-0141-003 (3-ft cable)
- Part number 44-0141-010 (10-ft cable)

Note: The conversion card cables are not required for CE compliance.

AC Line Filters

AC line filters are required for EMC compliance.

Part Number	Description	ULTRA Plus
9101-1517	10A, 1 ϕ	1398-PDM-10
9101-1518	23A, 1 ϕ	1398-PDM-20
9101-1387	36A, 1 ϕ	1398-PDM-30
9101-1388 ¹	50A, 1 ϕ	For multiple drives using one filter
9101-1389	36A, 3 ϕ	1398-PDM-75
9101-1390 ¹	80A, 3 ϕ	For multiple drives using one filter

¹ For multiple drives using one filter, the combined drive input currents must not exceed filter current rating.

Shielded Power Cables

Shielded power cables are required for EMC compliance.

Motor	Part Number ¹
F-4000, H-4000	9101-1382-xxx
F-6000, H-6000	9101-1383-xxx
H-2000, H-3000	9101-1381-xxx
N-Series	9101-1467-xxx

¹ The last three digits select standard cable lengths of: 10 ft (3.0m)—010; 25 ft (7.7m)—025; 50 ft (15.0m)—050; 75 ft (23.0m)—075.

ULTRA Plus Optional Cables

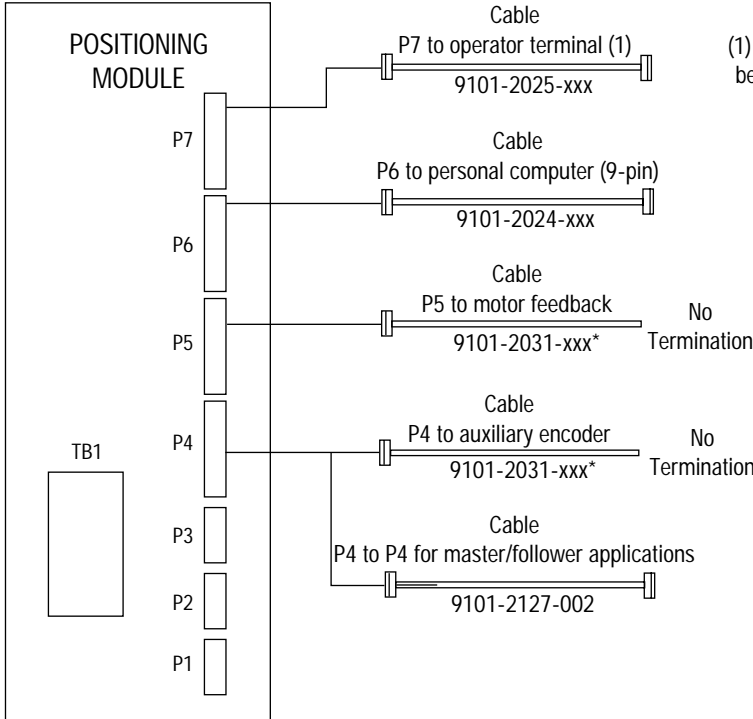

(1) P6 and P7 communication cables should be no longer than 50 ft (15.0 m) for RS-232

* Last three digits select standard cable lengths of
10 ft (3.0 m) - 010
25 ft (7.7 m) - 025
50 ft (15.0 m) - 050
75 ft (23.0 m) - 075

ULTRA Plus Transformer (0020-5093) and Power Supply (9101-0120) for 1398-PDM-25, -50, -100, and -150

ULTRA PLUS TRANSFORMER / POWER SUPPLY

Auxiliary power supply to maintain logic voltages when 3-phase power is turned off.

9101-0120 Auxiliary Logic Supply

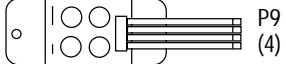

Includes four 2m (6 ft) cables

Transformer 0020-5093
Isolation Transformer
for Auxiliary Logic Supply

Note: Isolation Transformers are not required for operation but may be helpful in reducing electrical noise.

Power Supply Module Selection Guidelines (1398-PSM-25, -50, -100, and -150)

1398-PSM power supply modules should be selected based on the PSM rating required by your application. Up to six standard systems can be operated from a single power supply module. To select power supply modules:

1. Select the appropriate standard system(s) for your application.
2. Determine the total PSM rating by adding the PSM rating of each system chosen.
3. Select the power supply module with a PSM model number greater than your application total or select multiple PSMs, as required.

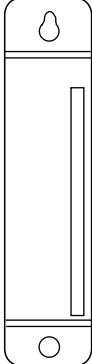

1398-PSM-50
Power
Supply

50A continuous

Shunt power
Continuous: 0.6 kW
Peak: 20 kW

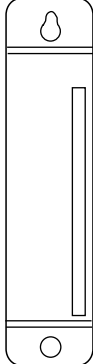

1398-PSM-125
Power
Supply

100A continuous

Shunt power
Continuous: 1.2 kW
Peak: 40 kW

For example, if your application uses the following:

Quantity	Motor	Drive	PSM Rating
1	H-8350-S-H00AA	1398-PDM-100	45
1	H-6200-Q-H00AA	1398-PDM-100	20

your total PSM rating is 65. The 1398-PSM-125 with a PSM rating of 125 is the power supply module that you need for your application.

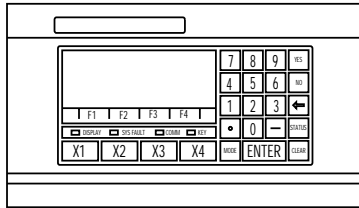

ULTRA Plus Operator Terminal

The 4x20 character vacuum fluorescent display provides you with an output of program-defined application messages. The terminal also allows you to input numeric and yes/no responses to application message prompts. This optional terminal is a powerful tool that allows you to customize operator interface terminology to your specific need.

Keys	Description
Function keys (F1, F2, F3, and F4)	Select from up to 24 factory-configured functions. You can define function key labels per your specific needs, such as Jog, Run, Stop, Home, Feed Rate, etc.
Unique X-keys (X1, X2, X3, and X4)	These keys are scanned by the application program. You are prompted for application specific input/output without interrupting program execution.
Status key	Scrolls through multiple factory-configured screens providing monitoring and troubleshooting information, such as Program status, I/O status, Position, Velocity, etc.

ULTRA Series Common Accessories

Operator Terminal (1398-HMI-002)

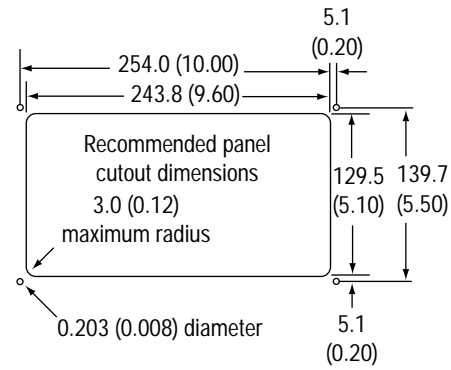
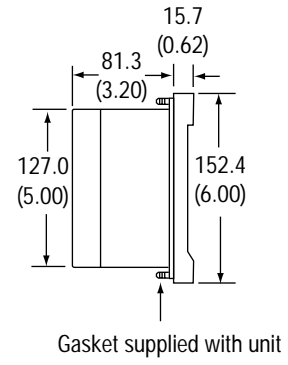
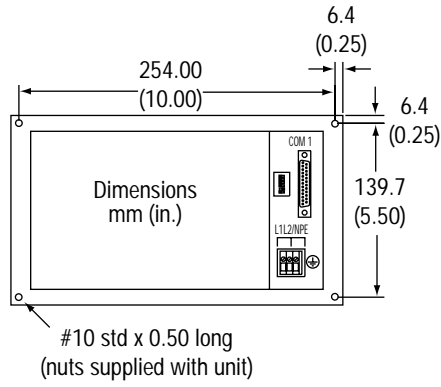
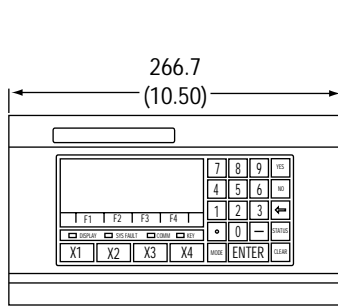

**AC Line Filter (9101-1387)
for 1398-DDM-030 and 1398-PDM-30 36A 1φ**

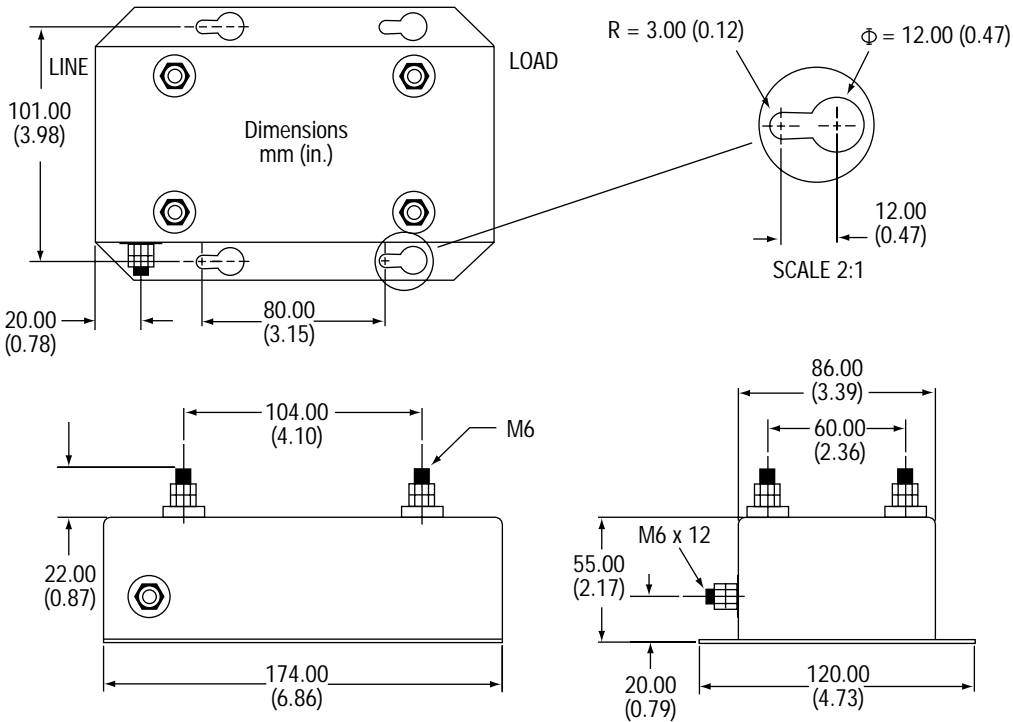

AC Line Filter (9101-1388) for Multiple Drives 50A 1φ

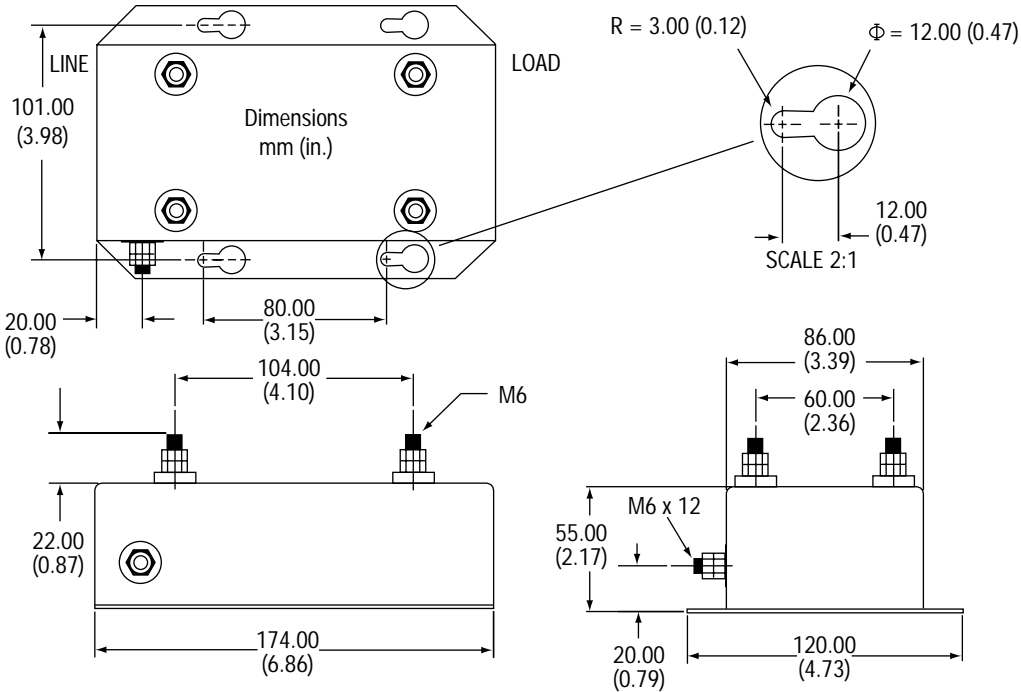

**AC Line Filter (9101-1389)
for 1398-DDM-075 and 1398-PDM-75 3A 3φ**

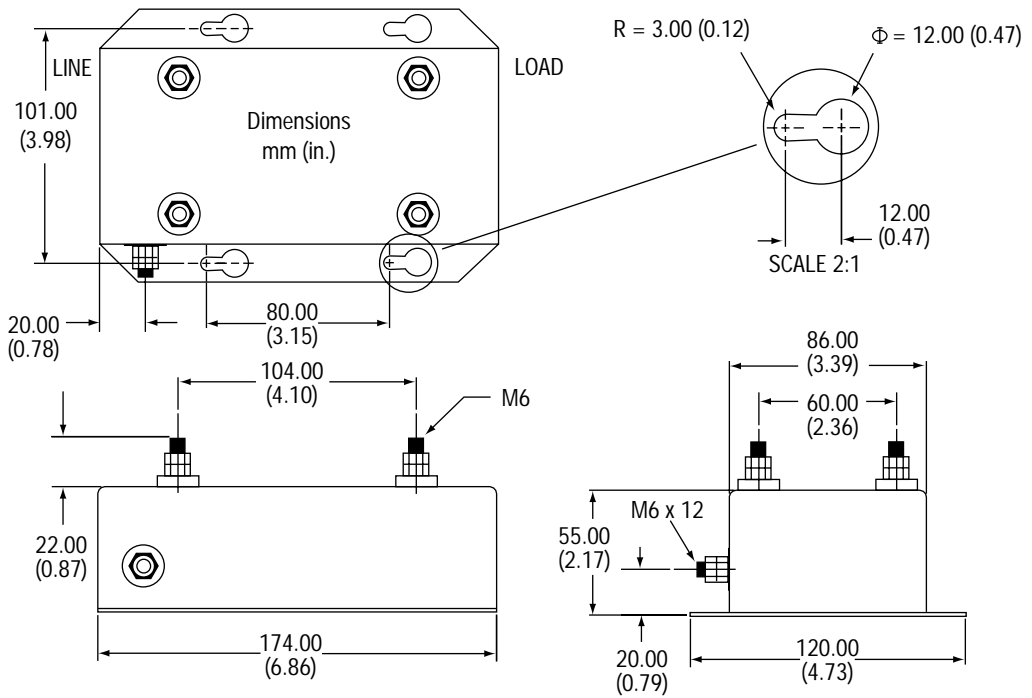

AC Line Filter (9101-1390) for Multiple Drives 80A 3φ

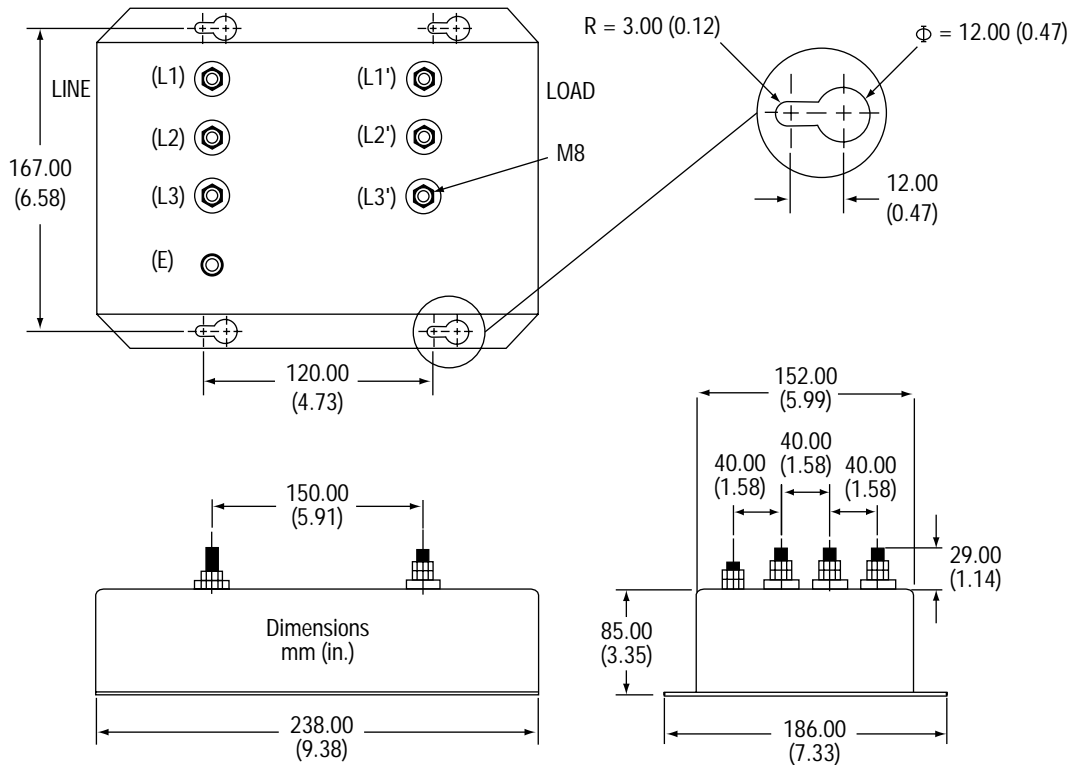

AC Line Filter (9101-1517)
for 1398-DDM-009, 1398-DDM-010, and 1398-PDM-10 10A 1 ϕ

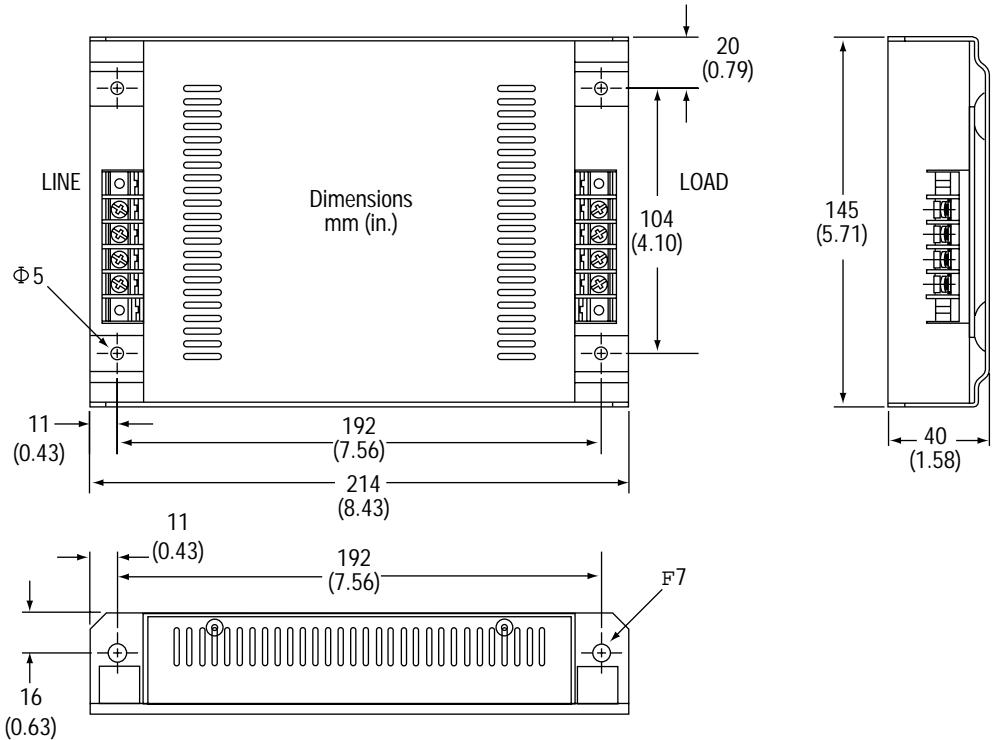

AC Line Filter (9101-1518)
for 1398-DDM-019, 1398-DDM-020, and 1398-PDM-20 23A 1φ

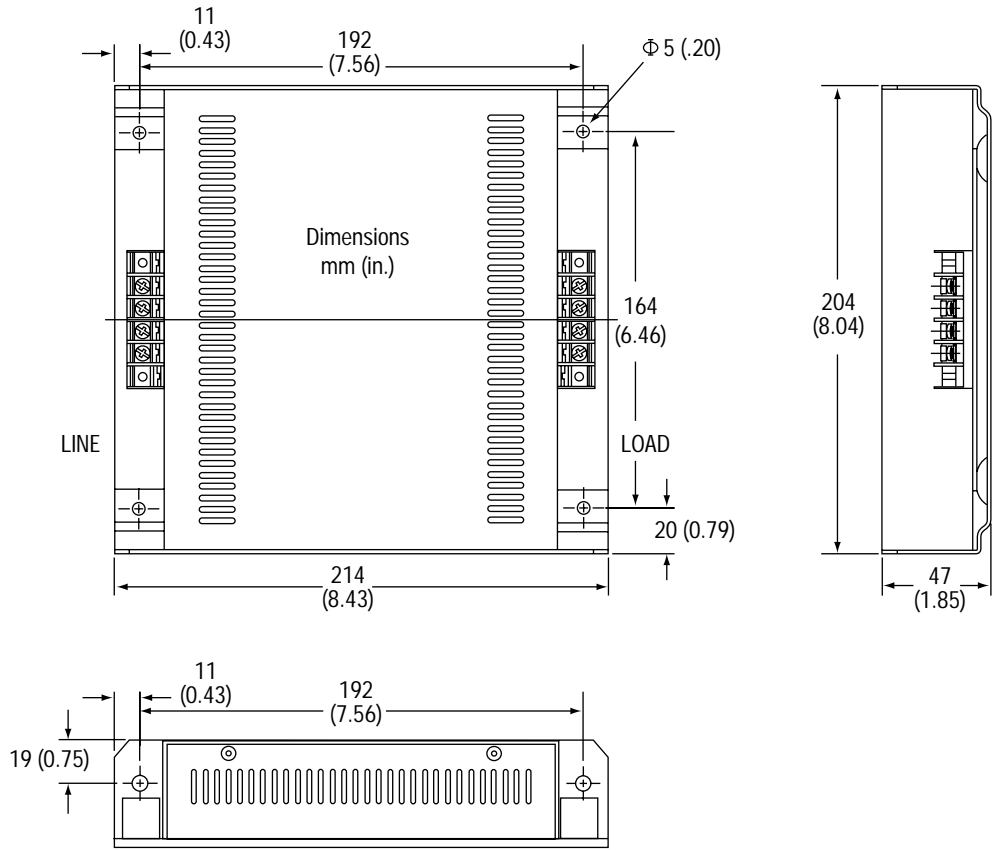

External Shunt Resistor Kit (9101-1183)
for 1398-DDM-010, -020, -030 and 1398-PDM-10, -20, -30

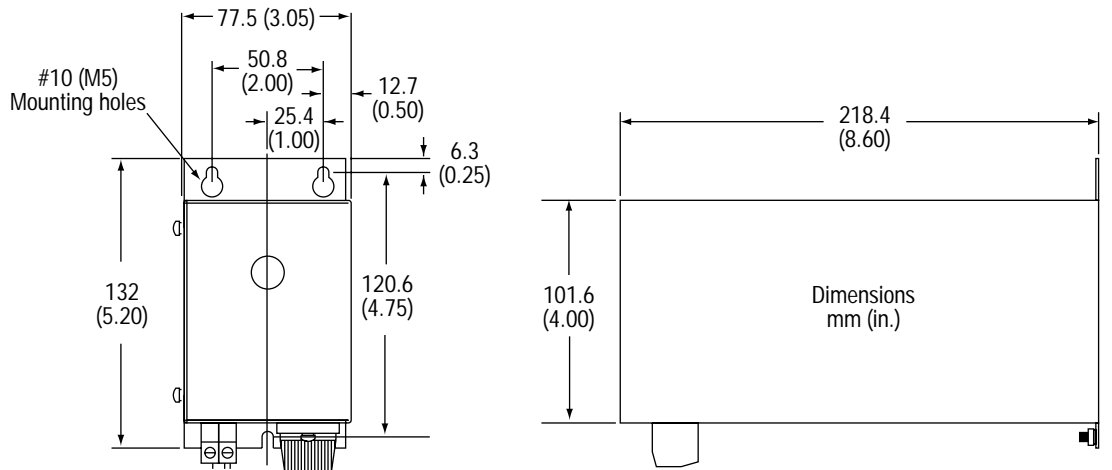

Passive External Shunt Module (1398-SR9P) for 1398-DDM-075, 1398-DDM-150, and 1398-PDM-075

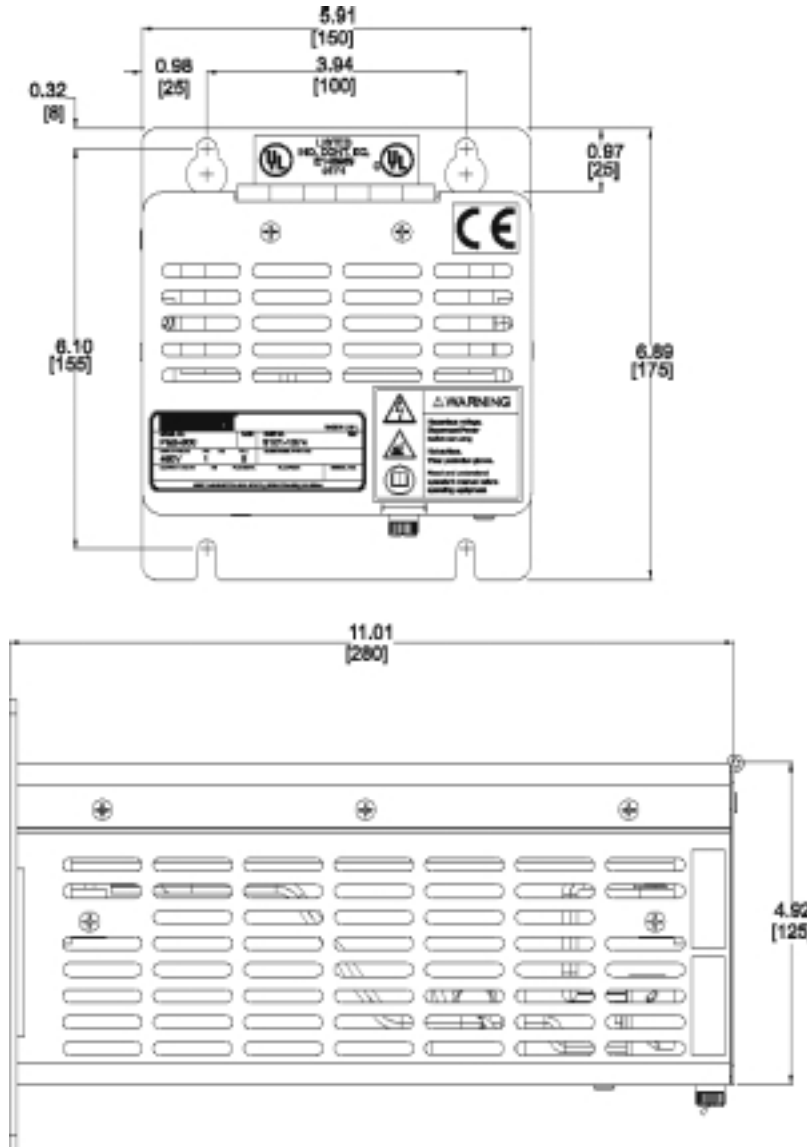

www.rockwellautomation.com

Power, Control and Information Solutions Headquarters

Americas: Rockwell Automation, 1201 South Second Street, Milwaukee, WI 53204-2496 USA, Tel: (1) 414.382.2000, Fax: (1) 414.382.4444

Europe/Middle East/Africa: Rockwell Automation, Vorstlaan/Boulevard du Souverain 36, 1170 Brussels, Belgium, Tel: (32) 2 663 0600, Fax: (32) 2 663 0640

Asia Pacific: Rockwell Automation, Level 14, Core F, Cyberport 3, 100 Cyberport Road, Hong Kong, Tel: (852) 2887 4788, Fax: (852) 2508 1846

ULTRA Series, ULTRA 100, and ULTRA 200 are registered trademarks of Rockwell Automation.

Microsoft is a registered trademark of Microsoft Corporation.

Windows is a trademark of Microsoft Corporation.

UL and cUL are registered trademarks of Underwriters Laboratories.

For more information refer to our web site: **www.ab.com/motion**

For Rockwell Automation Technical Support information refer to: www.rockwellautomation.com/support or Tel: (1) 440.646.3434