

DR[®] ROTO-HOG[™] Power Tiller

SAFETY & OPERATING INSTRUCTIONS

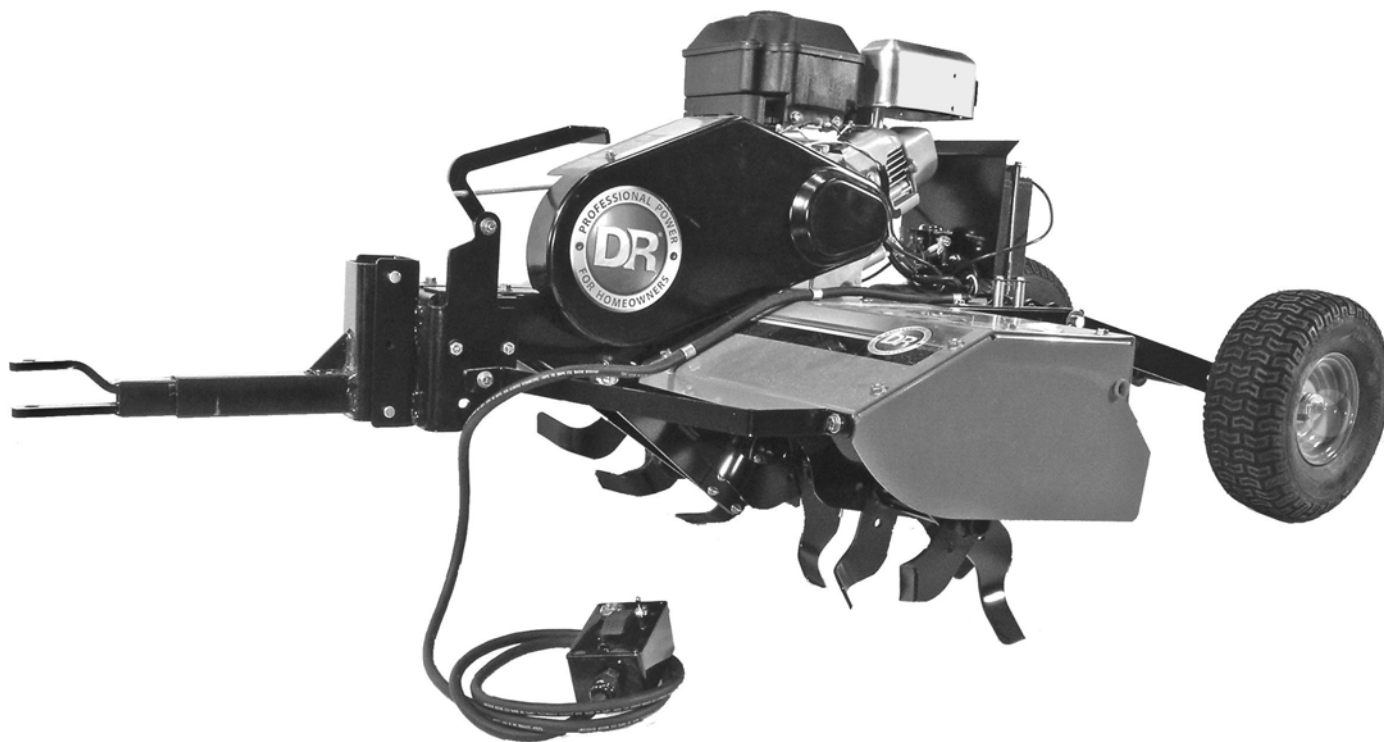

DR[®] Power Equipment
A division of Country Home Products[®]

Toll-free phone: 1-800-DR-OWNER (376-9637)

Fax: 1-802-877-1213

Web site: www.DRpower.com

Serial No. _____

Order No. _____



Read and understand this manual and all instructions before operating this DR Roto-Hog Power Tiller.

Table of Contents

Chapter 1: General Safety Rules.....	3
Chapter 2: Setting Up Your DR ROTO-HOG Power Tiller.....	7
Chapter 3: Operating Your DR ROTO-HOG Power Tiller.....	14
Chapter 4: Maintaining The DR ROTO-HOG Power Tiller.....	19
Chapter 5: Troubleshooting.....	24
Chapter 6: Parts Lists, Schematic Diagrams And Warranty.....	26

Conventions used in this manual

WARNING!

This indicates a hazardous situation, which, if not avoided, could result in death or serious injury.

CAUTION!

This indicates a hazardous situation, which, if not avoided, could result in minor or moderate injury.

NOTICE!

This information is important in the proper use of your machine. Failure to follow this instruction could result in damage to your machine or property.

If you are ever unsure about an action you are about to take, don't do it, visit our website at www.DRPower.com for help or information.

Serial Number and Order Number

A Serial Number is used to identify your machine. The number is located on the serial number label on your machine. For your convenience and ready reference, enter the Identification number in the space provided on the front cover of this manual. An Order Number is used to check and maintain your order history. The number is located on the upper left portion of your packing slip. For your convenience and ready reference, enter the order number in the space provided on the front cover of this manual.

Additional Information and Potential Changes

DR Power Equipment reserves the right to discontinue, change, and improve its products at any time without notice or obligation to the purchaser. The descriptions and specifications contained in this manual were in effect at printing. Equipment described within this manual may be optional. Some illustrations may not be applicable to your machine.

Chapter 1: General Safety Rules

WARNING!

Read this *safety & operating instructions* manual before you use the DR Roto-Hog power tiller. Become familiar with the service recommendations to ensure the best performance from your tiller.

Labels

Your DR ROTO-HOG Power Tiller carries prominent labels as reminders for its proper and safe use. Shown below are copies of the safety and information labels that appear on the equipment. Take a moment to study them and make a note of their location on your DR ROTO-HOG Power Tiller as you assemble and before you operate the machine. Replace damaged or missing safety and information labels immediately.



**DR® ROTO-HOG™
POWER TILLER**

**PROFESSIONAL POWER
DR
FOR HOMEOWNERS**

⚠ WARNING!

AVOID SERIOUS INJURY OR DEATH

- RAISE TINES OUT OF GROUND BEFORE STARTING ENGINE OR ENGAGING CLUTCH
- READ AND FOLLOW DIRECTIONS IN OWNER'S MANUAL
- DISENGAGE TINE CLUTCH LEVER BEFORE STARTING
- KEEP ALL SAFETY FEATURES IN PLACE AND OPERATING
- AVOID CONTACT WITH MOVING PARTS. KEEP HANDS AND FEET AWAY FROM TINES
- STOP ENGINE BEFORE FUELING, ADJUSTING OR INSPECTING. DO NOT ADD FUEL TO AN ENGINE THAT IS RUNNING OR HOT
- KEEP BYSTANDERS 25 FT AWAY FROM MACHINE
- NEVER ALLOW CHILDREN OR UNINSTRUCTED ADULTS TO OPERATE MACHINE

TO START...

- Raise tines out of ground
- Start tiller engine
- Move throttle control to full speed
- Push back on the tine clutch lever to start tines rotation
- Select lowest tractor ground speed
- Set tractor throttle at or just above idle

TO STOP...

Tines

- Raise tines out of ground
- Pull forward on the tine clutch lever

Engine

- Move throttle control to "STOP" position
- Never use choke to stop engine

TINE CLUTCH LEVER

⚠ WARNING!

RAISE TINES OUT OF GROUND BEFORE ENGAGING CLUTCH

↑
ENGAGED
To engage,
Push Back.

↓
To disengage,
Pull Forward.
DISENGAGED

DR POWER EQUIPMENT
75 Meigs Road, Vergennes, VT 05491
1-800-DR-OWNER www.DRpower.com

224531A

#224531A

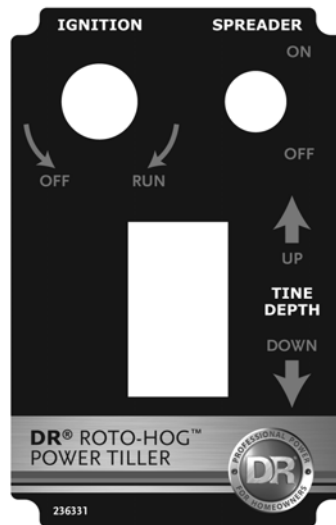

IGNITION **SPREADER**

OFF RUN OFF ON

↑
TINE
DEPTH
↓

**DR® ROTO-HOG™
POWER TILLER**

**PROFESSIONAL POWER
DR
FOR HOMEOWNERS**

236331

#236331



⚠ WARNING

TO AVOID SERIOUS INJURY, DO NOT OPERATE WITHOUT BELT GUARD AND ALL OTHER SHIELDS IN PLACE AND IN GOOD CONDITION

224511

#224511



WARNING

KEEP AWAY FROM ROTATING TINES
ROTATING TINES WILL CAUSE INJURY

224521

#224521

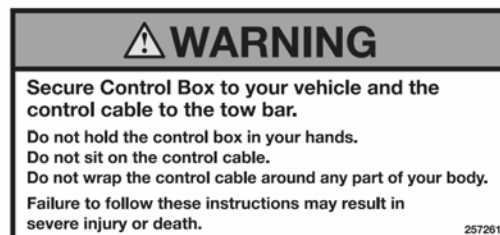

⚠ WARNING

Secure Control Box to your vehicle and the control cable to the tow bar.

Do not hold the control box in your hands.
Do not sit on the control cable.
Do not wrap the control cable around any part of your body.

Failure to follow these instructions may result in severe injury or death.

257261

#257261

Protecting Yourself and Those Around You

WARNING!

The DR ROTO-HOG power tiller is a high-powered machine with fast moving parts operating at high speeds. You must operate this machine safely. Unsafe operation can create hazards for you, as well as anyone else in the work area. Use proper clothing and safety gear when operating this machine to prevent or minimize the risk of severe injury. Always take the following precautions when operating the DR ROTO-HOG power tiller:

- Always wear protective goggles or safety glasses with side shields to protect your eyes from possible objects thrown from the machine.
 - We recommend wearing safety shoes when using this machine. Wear shoes with non-slip treads to improve footing on slippery surfaces. Do not use the machine wearing open sandals or while barefoot.
 - Do not wear loose clothing or jewelry, which can catch on the machine's moving parts.
 - We recommend wearing long pants and gloves while using this machine. Be sure the gloves fit properly and do not have loose cuffs or drawstrings.
 - We recommend the use of ear protectors or ear plugs rated for at least 20 dba to protect your hearing.
 - Allow only responsible individuals who are familiar with these general safety rules and operating instructions to use your DR ROTO-HOG power tiller. Never allow people who are unfamiliar with these rules and instructions to use your machine.
 - Have a complete working knowledge of your tow vehicle and know how to handle it with the DR ROTO-HOG power tiller attached.
 - Never place your hands, feet, or any part of your body near or under any moving part while the DR ROTO-HOG power tiller engine is running.
 - Never hold the control box or wrap it around any part of your body. Secure the control box to your tow vehicle with the hook and loop strap provided or with a similar device.
 - Keep bystanders away from your work area at all times. To be safe, do not operate the DR ROTO-HOG power tiller near children or pets, and never allow children to operate the machine. Stop the tow vehicle and the DR ROTO-HOG power tiller engine when another person or pet approaches.
 - Do not touch the muffler and engine when the machine is in use as they become very hot and can cause severe burns.
 - Clear the work area of objects that might jam or wrap around the tines such as glass, large sticks, stones, metal objects, wire, rope, and string-like materials. Use on these objects could damage the DR ROTO-HOG power tiller and/or cause injury.
 - Do not use this machine around large roots and surface rocks that you cannot remove.
 - Do not use this machine around underground pipes and wiring.
 - Never engage the tines when they are in the ground. If the DR ROTO-HOG power tiller engine should stall, raise the tines out of the soil and disengage them.
 - Never, under any conditions, remove, bend, cut, fit, weld, or otherwise alter standard parts on the DR ROTO-HOG power tiller. This includes all shields and guards. Modifications to your machine could cause personal injuries and property damage and will void your warranty.
-

Slope Operation

WARNING!

Use of machinery on slopes is a major factor related to accidents, which can result in severe personal injury. Use of machinery on slopes requires caution. If you feel uneasy using the DR ROTO-HOG power tiller on a slope, do not operate it. Always take the following precautions when using this machine on slopes:

Always:

- Exercise extreme caution when changing direction on slopes.
 - Watch for holes, ruts, and bumps on the ground.
-

! WARNING!

Never:

- Never operate near drop-offs, ditches, or embankments; you could lose control of your tow vehicle and/or the DR ROTO-HOG power tiller.
 - Never operate on slopes greater than 5 degrees, or on any excessively steep slope.
 - Never operate on wet, or slippery slopes. Reduced traction could result in tipping over your tow vehicle and/or the DR ROTO-HOG power tiller.
 - Never park the tow vehicle on a steep grade or slope.
-

Safety for Children

! WARNING!

Tragic accidents can occur if the operator is not alert to the presence of children. Children can be attracted to the DR ROTO-HOG power tiller and its tilling activity. Never assume that children will remain where you last saw them.

- Keep children out of the work area and under the watchful care of a responsible adult.
 - Be alert and always turn off your tow vehicle and the DR ROTO-HOG power tiller engine if children enter the work area.
 - Before, and while moving your tow vehicle backwards, look behind, and down for small children.
 - Never allow children to operate the DR ROTO-HOG power tiller.
 - Use extra care when approaching blind corners, shrubs, trees, or other objects that may obscure your vision.
-

Safety with Gasoline-Powered Machines

! WARNING!

Gasoline is a highly flammable liquid. Gasoline also gives off flammable vapor that can be easily ignited and cause a fire or explosion. Never overlook the hazards of gasoline and always follow these precautions:

- Never run the DR ROTO-HOG power tiller engine in an enclosed area or without proper ventilation as the exhaust from the engine contains carbon monoxide, which is an odorless, tasteless, and deadly poisonous gas.
 - Store all fuel and oil in containers specifically designed and approved for this purpose and keep away from heat, open flame, and out of the reach of children.
 - Fill the gasoline tank outdoors with the engine off and allow the engine to cool completely. Do not handle gasoline if you or anyone nearby is smoking, or if you are near anything that could cause it to ignite or explode. Replace the fuel tank and fuel container caps securely.
 - If you spill gasoline, do not attempt to start the engine. Move the machine away from the area of the spill and avoid creating any source of ignition until the gas vapors have dissipated. Wipe up any spilled fuel to prevent a fire hazard and properly dispose of the waste.
 - Allow the DR ROTO-HOG power tiller engine to cool completely before storing in any enclosure. Never store the machine with gas in the tank or with gas in a fuel container near an open flame or spark such as a water heater.
 - Never make adjustments or repairs with the engine running. Before making an adjustment or repair, shut off the DR ROTO-HOG power tiller engine, wait five (5) minutes to cool, then disconnect the spark plug wire and keep the wire away from the spark plug to prevent accidental starting.
 - Never check for an ignition spark with the spark plug or spark plug wire removed. Always use an approved spark tester.
 - Never tamper with safety devices. Regularly check their proper operation.
 - Never change the engine governor settings or modify the engine speed. Modifications will void your warranty.
 - To reduce fire hazard, keep the engine and muffler area free of debris build-up such as leaves, grass, oil, grease, or any other combustible material. Clean the engine area after each use.
 - Never operate the engine without the muffler. Inspect the muffler periodically and replace if necessary. If the engine is equipped with a muffler deflector, inspect it periodically and replace if necessary.
-

! WARNING!

- Never operate the engine with the air cleaner or cover over the carburetor air intake removed, except for adjustment. Removal of such parts could create a fire hazard. Do not use flammable solutions to clean the air filter.
 - Always check fuel lines and fittings frequently for cracks or leaks, replace if necessary.
 - Replace rubber fuel lines and grommets when worn or damaged, but do not use over five (5) years.
-

General Safety

! WARNING!

Safe operation of the DR ROTO-HOG power tiller is necessary to prevent or minimize the risk of ***death or serious injury***. Unsafe operation can create a number of hazards for you. Always take the following precautions when operating this machine:

- The DR ROTO-HOG power tiller is a powerful tool and not a plaything. When using this machine, exercise extreme caution at all times. The design of this machine is to till soil. Do not use it for any other purpose.
 - The operator or user of the DR ROTO-HOG power tiller is responsible for accidents or hazards occurring to other people, their property, and themselves.
 - Know how to quickly stop the DR ROTO-HOG power tiller. See page 15.
 - Never allow people or pets to ride on this machine.
 - If the machine should make an unusual noise or vibration, shut off the tow vehicle and the DR ROTO-HOG power tiller engines. Vibration is generally a warning of trouble. Wait five (5) minutes for the DR ROTO-HOG power tiller engine to cool. Disconnect the spark plug wire and then inspect the machine for clogging, damaged tines, or loose engine mounting bolts. Clear any obstructions and repair and/or replace damaged parts.
 - Always keep the machine in good safe operating condition. Always make certain nuts and bolts are tight and always use the supplied self-locking hardware. Do not use substitute hardware.
 - Always shut off the tow vehicle and DR ROTO-HOG power tiller engine, wait five (5) minutes to cool, and disconnect the spark plug wire before attempting to clear any obstructions.
 - Use the DR ROTO-HOG power tiller only in daylight and give complete and undivided attention to the job at hand.
 - Do not hurry or take things for granted when using the DR ROTO-HOG power tiller. When in doubt about the machine or your surroundings, stop the machine and take time to look things over.
 - Exercise extreme caution when on or crossing drives, walks, or roads. Stay alert for hidden hazards or traffic.
 - Never leave the DR ROTO-HOG power tiller unattended with the engine running. If leaving the machine, shift the tow vehicle into neutral, set the vehicle parking brake, turn off the vehicle engine and remove key; raise the tines of the tiller and disengage the tine drive, turn off the tiller engine and, if electric start, remove the tiller key.
 - Prior to transportation to and from the work area, disengage the tiller tine drive, stop the tiller engine, and raise the tines.
 - Do not operate the machine when under the influence of alcohol, drugs, or medication.
 - See manufacturer's instructions for proper operation and installation of accessories. Only use accessories approved by DR power equipment.
 - No list of warnings and cautions can be all-inclusive. If situations occur that are not covered by this manual, the operator must apply common sense and operate the DR ROTO-HOG power tiller in a safe manner. Visit our website at www.drpower.com or call **1-800-dr-owner (376-9637)** for assistance.
-

A Note to All Users

Under California law, and the laws of some other states, you are not permitted to operate an internal combustion Engine using hydrocarbon fuels without an Engine Spark Arrester. This also applies to operation on US Forest Lands. All DR ROTO-HOG power tillers shipped to California and Washington State are provided with spark arresters. Failure of the owner/operator to maintain this equipment in compliance with state regulations is a misdemeanor under California law and may be in violation of other state and/or federal regulations. Contact your local Fire Marshal, Forest Service, State Park Association, or the appropriate state organization for specific information in your area.

Chapter 2: Setting Up Your DR ROTO-HOG Power Tiller

It may be helpful to familiarize yourself with the controls and features on your new machine by reviewing Figure 1 before beginning the steps outlined in this chapter. For technical assistance, please visit our website at www.DRPower.com.

DR ROTO-HOG Power Tiller Controls and Features

NOTE: The model shown in Figure 1 may look slightly different from your machine.

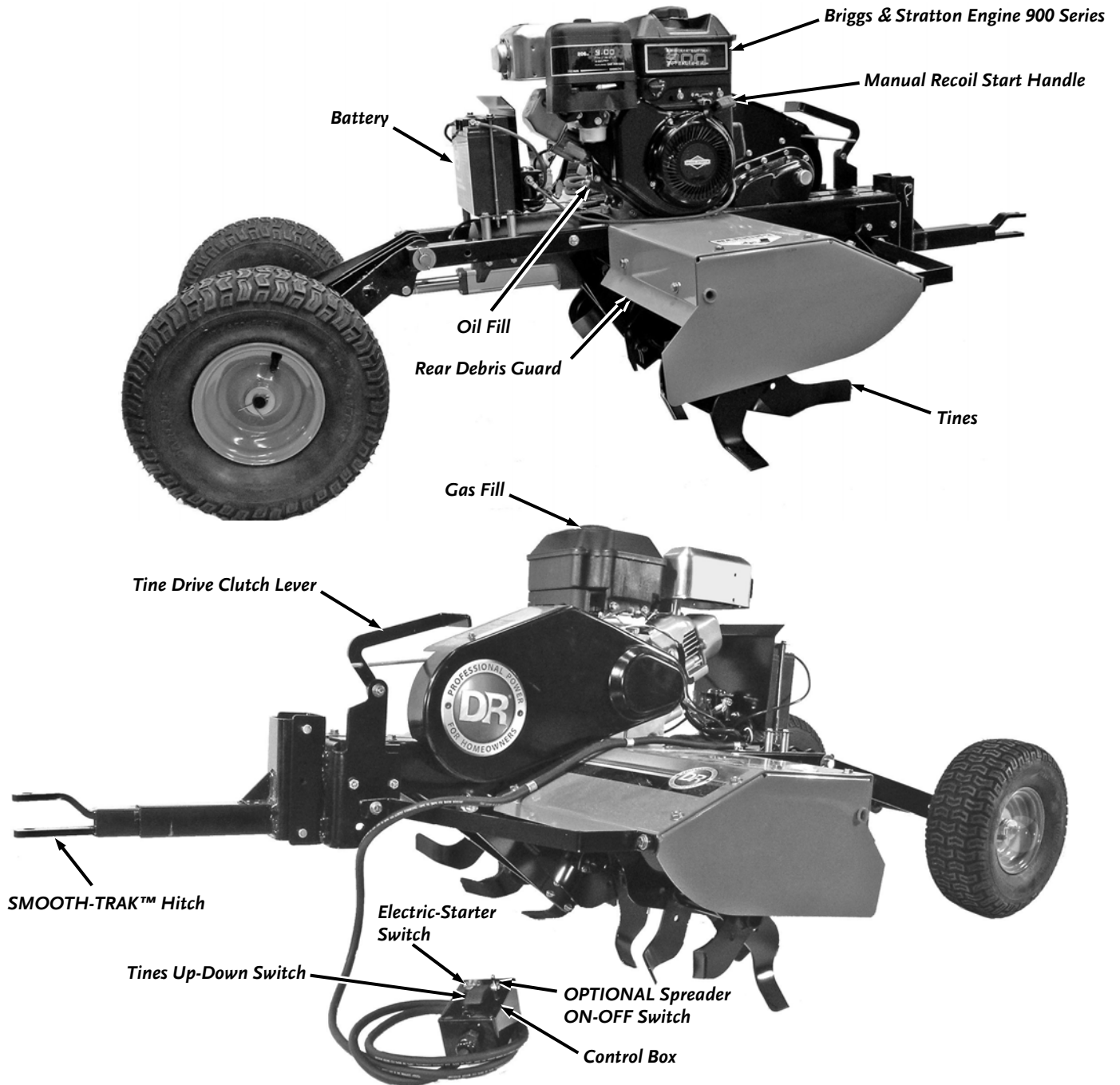

Figure 1

DR ROTO-HOG Power Tiller Specification Sheet

Engine	Briggs & Stratton 9.00 FPT, 206 CC, Single Cylinder
Approximate Run Time on a Tank of Fuel	90 minutes
Battery	12 Volt, 9AH
Towing type	Pin Hitch
Ground Clearance in Transport Mode	2.75"
Height Adjustment	Electric Actuator
Range	7" deep
Actuator Stroke	3.94"
Actuator Maximum Load	250 lbs.
Length of Remote Control Cable	46"
# of Cycles for Fully Charged Battery	400
Tine Size	12"
Number of Tines	24
Wheels	15" x 6.00"-6 NHS (14" x 5.5")
Machine Size	39"w x 66"L (Transport), 35"H x 77"L (Lowest Position)
Machine Weight	237 lbs. Manual Start, 242 lbs. Electric Start
Tongue Weight	90 lbs. (Transport) 112 lbs. (Lowest Position)
Shipping Weight	310 lbs. Manual Start, 320 lbs. Electric Start
Gauge of Steel on Shroud	13
Gauge of Steel on Frame	12 Gauge, 1.5" Tubular Steel

Unpacking and Assembling the Machine

NOTE: Unpacking and assembling the DR ROTO-HOG Power Tiller is a two-person job, as the Manual Start Unit weighs 237 pounds and the Electric Start Unit weighs 242 pounds. We recommend you have an extra set of hands available before you begin.

Parts Supplied on Shipping Pallet:

- DR ROTO-HOG Power Tiller
- (2) Wheels
- Tow Bar w/SMOOTH-TRAK™ Hitch
- Battery w/Battery Bar
- Hardware Bag: (Located on the Gas Tank of the unit.)
 - (6) Shear Pin, 3/8" x 1-3/4"
 - (6) Hair Cotter Pin, 1/8" x 1-5/8"
 - (1) Battery Charger
 - (1) Alligator Clip Wire
 - (2) Flat Washer, 3/4"
 - (2) Cotter Pin, 3/16" x 2"
 - (1) Channel Pin, 1/2"
 - (1) Hair Cotter Pin, 5/32" x 3"
 - (1) *Safety & Operating Instructions* Manual
 - (1) Briggs & Stratton Engine Manual
 - (1) Hook & Loop Strap
 - (1) Battery Strap
 - (2) Bolt, 1/4" x 7-1/2"
 - (2) Lock Nut, 1/4"
 - (1) Clevis Pin, 3/8" x 4"
 - (1) Hair Cotter Pin, .08" x 1.58"

Tools and Supplies Needed:

- Pliers
- Grease Gun w/General purpose grease
- Knife
- Hammer or Mallet
- (2) 7/16" Wrench
- Gloves
- 1/2" Wrench or Socket



Stabilize the shipping container on a flat surface before attempting to unpack and assemble the machine.

1. Using Pliers, carefully remove the staples from the bottom corners of the cardboard box and lift it off the pallet (**Figure 2**). Be careful of the staples; they are sharp.
2. Using a Hammer or Mallet, remove the top and sides of the shipping crate (**Figure 3**).
3. Cut the Zip-Ties from around the Tires and Battery and remove them from the shipping pallet.
4. Remove the Hardware Bag from on top of the Gas Tank of the machine. Place the Battery in the Battery Bracket and secure it using the Battery Bar with two (2) 1/4" x 7-1/2" Bolts and 1/4" Lock Nuts from the Hardware Bag using two (2) 7/16" Wrenches (**Figure 4**).
5. Using a 1/2" Wrench or Socket, remove the three (3) screws securing the SMOOTH-TRAK™ Hitch to the shipping pallet (**Figure 5**).
6. Using the two (2) 4" Pins and Bow-Tie Cotter Pins from the Hardware Bag, attach the Tow Hitch to the machine (**Figure 6**).
7. Using a 1/2" Wrench, remove the four (4) Bolts from the Axle Hold-Down Brackets at the rear of the shipping pallet (**Figure 7** on page 10) and remove the Bracket from each Axle.

NOTE: At this point, you will have two (2) Screws from the Hitch, four (4) Screws from the Axle Brackets, and the two (2) Axle Brackets. All this hardware was for shipping and is NOT required for assembly.

8. Plug the Battery Cables onto the Battery Terminals (**Figure 4**).
9. Using the Control Box (**Figure 8** on page 10), lower the Tines all the way down, which will raise the Wheel Axles from the pallet.



Figure 2



Figure 3

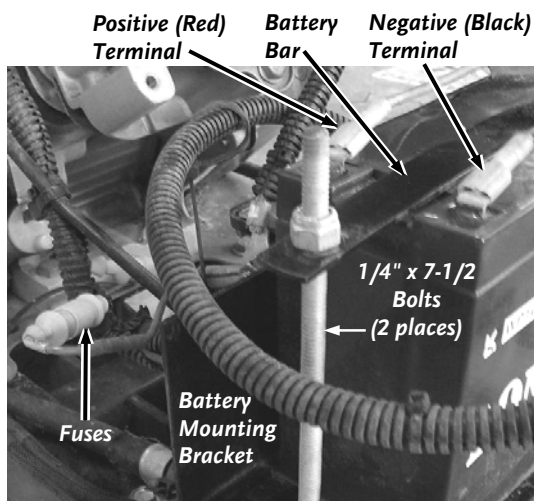

Figure 4

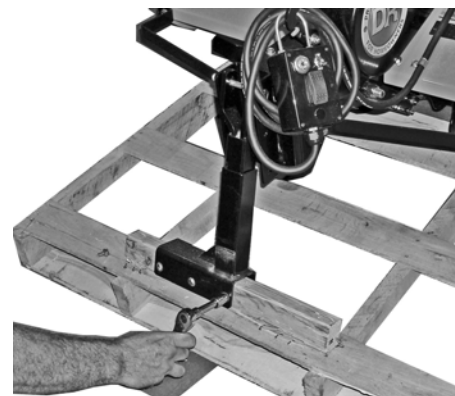

Figure 5

10. Slide a Wheel onto each Axle making sure that the Wheel Valve Stem is to the outside (**Figure 9**).
11. From the Hardware Bag, place one (1) Flat Wheel Washer on each Axle, slide a Cotter Pin through the Hole in the Axle on each side, and spread the Cotter Pin Legs using Pliers.
12. Grease the Grease Fittings on the Wheel Hubs with a Grease Gun just until Grease starts coming out of the Hub.
13. Raise the Tines (lowering the Wheels), and with the help of another person, pull the tiller from the shipping pallet. Do not discard your packaging material until you are fully satisfied with your new DR ROTO-HOG Power Tiller.

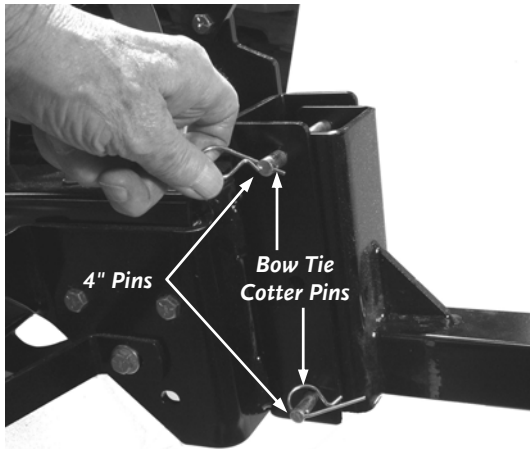

Figure 6

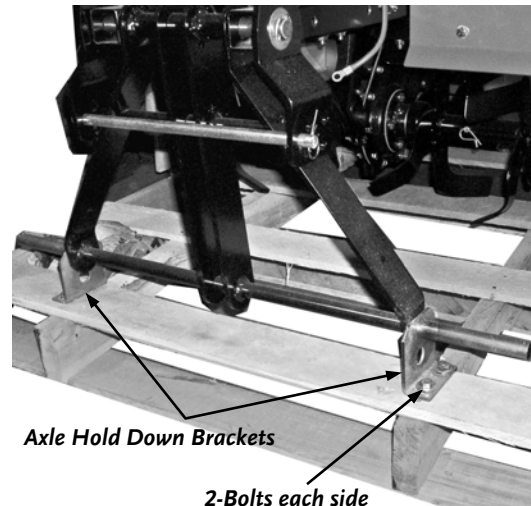

Figure 7

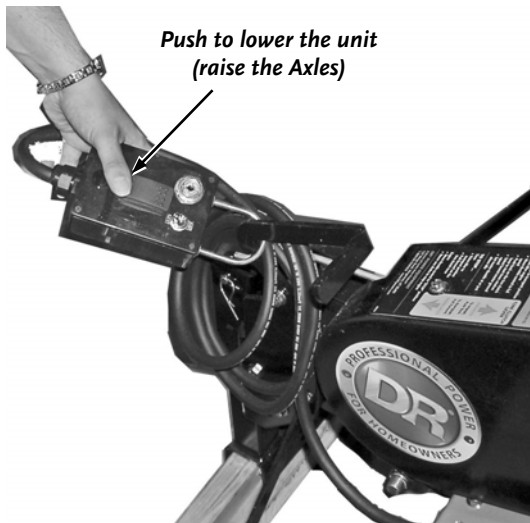

Figure 8

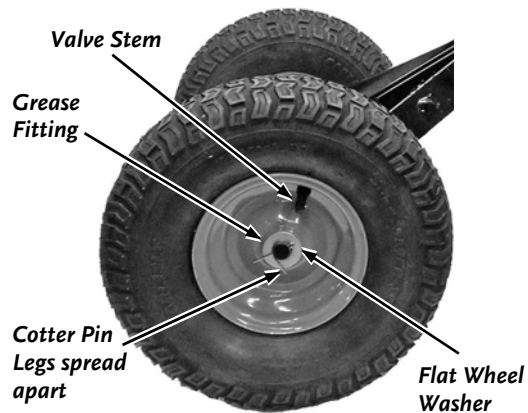

Figure 9

Charging the Battery

! WARNING!

Electrical hazard: prevent fire

- Never modify the DR ROTO-HOG power tiller's electrical system. Modifications could ruin the electrical system as well as cause a fire, resulting in serious injury.
- Using electrical components other than those supplied with your machine could cause the electrical system to overheat, explode, or start a fire.

! WARNING!

- Using the wrong type of battery or charger could cause a fire or explosion, resulting in serious injury.
 - Use the 12-volt charger supplied with your machine or a 12-volt, 2 amp max, substitute charger to charge the battery.
 - Use the charger only in dry locations. Avoid contact with water.
 - Only adults should handle the battery. It contains sulfuric acid (an electrolyte) and the battery is heavy; dropping it could result in serious injury.
 - Never allow children to charge the battery. The electricity involved in charging the battery could cause severe injury.
 - Examine the charger, its connectors, and the battery for excessive wear or damage each time you charge the battery. If you see any excessive wear or damage, do not use the charger or the battery, replace them.
 - Never lift or carry the battery by the cables or terminals. This can damage the battery and possibly start a fire, resulting in serious injury. Lift and carry the battery only by its case.
 - Do not short circuit the battery.
-

About the Battery

The DR ROTO-HOG Power Tiller comes with a 12-Volt, maintenance-free, rechargeable, sealed lead acid Battery. A fully charged Battery runs about 20 hours or 400 up/down cycles. Properly maintained and charged, the Battery provides years of dependable service.

Extra Wire

NOTE: *There is an extra wire in the Battery Wire Harness. This wire is for connection to an Optional Electric Spreader.*

Charging the Battery

Charging the Battery is a simple process. Leave the Battery in your DR ROTO-HOG Power Tiller when you charge it.

1. Attach the Black (-) Wire Terminal from the Charger to the (-) terminal of the Battery, then attach the Red (+) Wire Terminal to the (+) Battery terminal.
 2. Plug the Charger into a standard wall outlet.
- Typically, the Battery takes between 6 and 8 hours to fully charge. The Battery does not have a “memory”; so don’t worry about overcharging the Battery or charging it too often.
 - You can charge the Battery many times. The Battery lasts longer if you charge it before it is fully drained. Keep it fully charged and at room temperature when not using your DR ROTO-HOG Power Tiller.
 - Once the Battery is charged, pull the plug from the wall outlet and then remove the Charger from your Battery. However, you can leave your Battery plugged in and charging for an extended period.
 - Store the Charger in its self-locking plastic shipping bag. Keep the Charger in a dry location.
 - If the Battery does not hold its charge for very long under normal conditions or it simply won’t hold a charge, then replace it. You can purchase replacement Batteries directly from us. To install your new Battery, detach the cables, remove the Battery Clamp, and remove the dead Battery. Next, install the new Battery, replace the Battery Clamp, and attach the cables. Refer to the assembly instructions for more details on page 9.

! NOTICE!

When the battery gets old and no longer accepts a charge, remove it from your DR ROTO-HOG Power Tiller. Never leave a dead battery in your machine.

Adding the Engine Oil and Gasoline

! NOTICE!

- You must add oil before starting the engine. This machine is shipped without oil. Traces of oil may be in the reservoir from factory testing, but you must add oil before starting the engine. Fill the reservoir slowly, checking the level frequently, to avoid overfilling.
- To get an accurate reading when checking the oil level the machine should be on a level surface.

Capacities	
Briggs & Stratton - 900 Series, 9.00 FPT, OHV	⇒ SAE 30 High Detergent Oil – 20 oz. (.60L)
Gasoline Tank	⇒ Unleaded Gas (85 Octane minimum), 3.0 Qts. (2.8 L)

Tip: To avoid confusion, we recommend leaving the Caps on the Fuel and Engine Oil Fills and only removing one Cap each time when you are ready to pour gasoline or oil into the correct Fill.

NOTE: Use SAE 30 High Detergent oil classified “For Service SF, SG, SH, SJ” or higher. Do not use special additives. Other types of oil could cause problems operating your machine. Please refer to your Engine Owner’s Manual for detailed oil information.

1. Place the machine on a level surface and initially add 16 oz. (1/2 quart) of SAE 30 High Detergent oil, recommended by the Engine Manufacturer, and wait one minute for the oil to settle (**Figure 10**).
2. Continue adding a few ounces of oil at a time, until the oil reaches just below the threads. Be careful not to overfill.
3. Fill the Gas Tank with fresh, unleaded gas (with a minimum of 85 Octane), to approximately 1" to 1-1/2" below the top of the Fill Neck to allow for Fuel expansion. Be careful not to overfill and reinstall the Cap before starting the Engine. See your Engine Owner’s Manual for more information.

NOTE: To refill the Gas Tank, turn the Engine OFF, and let the Engine cool at least five (5) minutes before removing the Gas Fill Cap.

! WARNING!

Fill gas tank outdoors or in a well-ventilated area, away from sparks, open flames, pilot lights, heat, and other ignition sources.

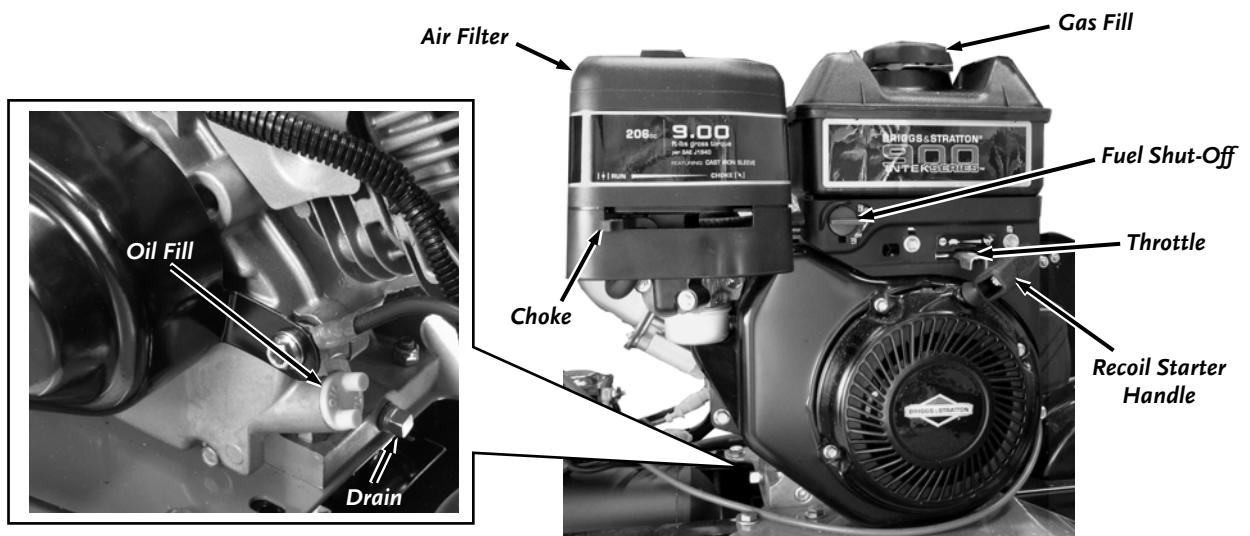

Figure 10

Connecting the DR ROTO-HOG Power Tiller to your Tow Vehicle

1. Back up your Tow Vehicle so that the Hitch of the Vehicle is in line with and next to the Hitch on the DR ROTO-HOG Power Tiller. Set the Parking Brake on the Tow Vehicle.
2. Adjust the height of the Clevis on the Hitch on the DR ROTO-HOG Power Tiller using the Control Box for the Actuator so the Clevis is ready to attach to the Hitch of the Tow Vehicle.

NOTE: The height of machine is adjustable by +/- 3" by removing the two (2) Clevis Pins (**Figure 11**) and re-positioning the Hitch up or down. The lower the front of the frame, the deeper the Tine depth for tilling, but you will lose transport height.

3. Remove the Hair Clevis Pin and Clevis Pin from the Clevis. Back the Tow Vehicle so the Hitch on the Tow Vehicle goes into the Clevis. Set the Parking Brake on the Tow Vehicle and reinstall the Clevis Pin and Hair Clevis Pin (**Figure 11**).
4. Remove any slack coming from the Tiller as you secure the Control Cable to the Tiller Frame and Tow Bar with Cable Ties.

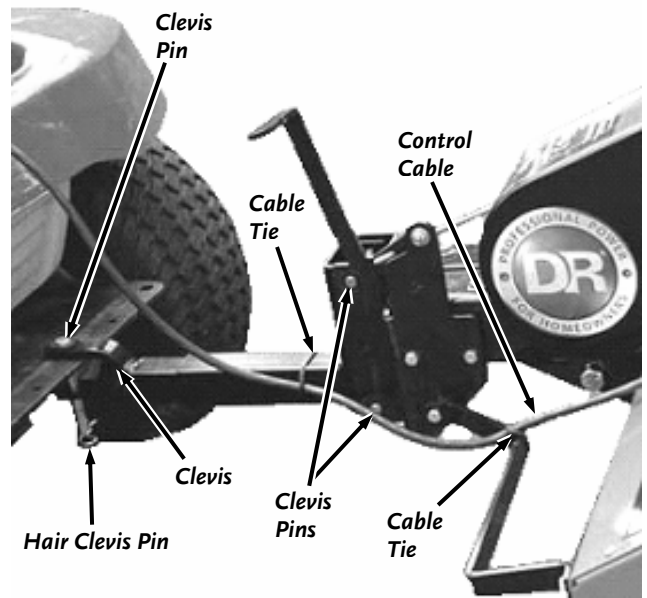

Figure 11

Attaching the DR ROTO-HOG Power Tiller Control Box

There are two (2) options for attaching the Control Box:

- Hang the Control Box by the attached U-Bolt (**Figure 12**) in an accessible and comfortable position on your Tow Vehicle from which you can operate the Control Box; or,
- Attach the Control Box on a clean flat surface using the self-adhesive Hook and Loop strips provided with the DR ROTO-HOG Power Tiller (**Figure 12**).

! WARNING!

Do not hold the Control Box by putting the cord under your leg or any other part of your body. Secure the Control Box to the tow vehicle only. If the cord gets caught in the tines, the Control Box may be yanked from its secured position. Be sure you are not in its path.

NOTE: To prevent the Control Cable from entering the Tines during operation, coil up any excess Cable on the Tow Vehicle side and secure with a Cable Tie. Make sure you leave enough Cable length to accommodate turns.

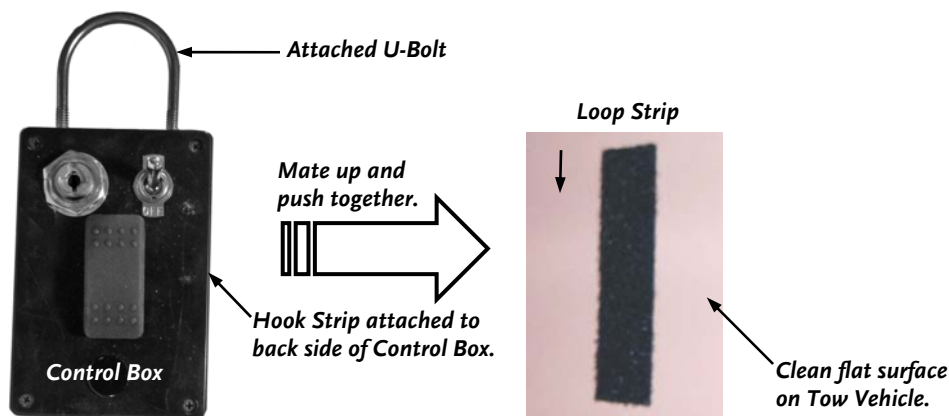

Figure 12

Chapter 3: Operating Your DR ROTO-HOG Power Tiller

There are three (3) applications for the DR ROTO-HOG Power Tiller: Garden Tilling, Sod Busting, and small Food Plot installation.

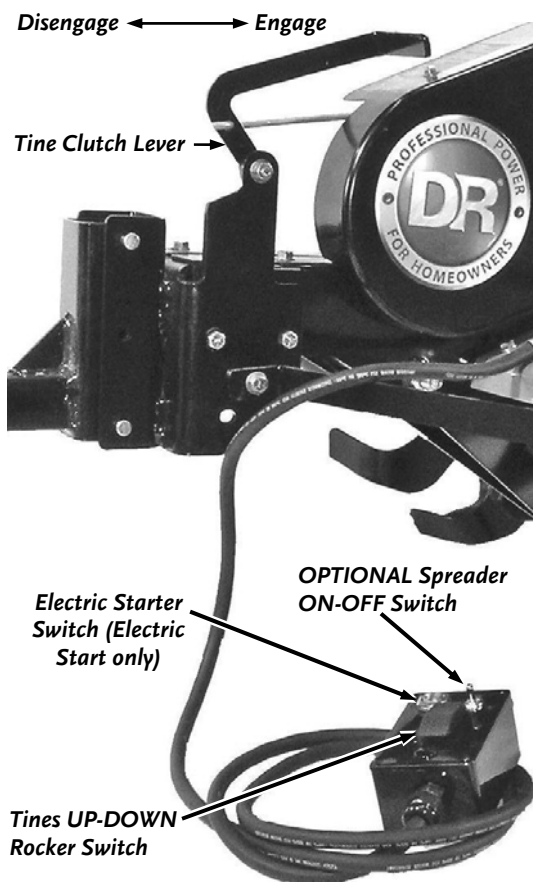

Figure 13

3. Check the gasoline level (**Figure 10** on page 12).
4. Remove any built up debris from the Tines.
5. Pull the Tine Clutch Lever all the way forward until it locks into place to disengage the Tines. A Safety Interlock Switch prevents the Engine from starting with the Tines engaged.
6. Turn the Fuel Shut-Off to the ON position (**Figure 10** on page 12).

Manual Starting

NOTE: You may use this starting method even though the DR ROTO-HOG Power Tiller may be equipped with Electric Starting; however, make sure the Key is in the RUN position.

1. When starting a cold Engine, push the Choke Control Lever to the right (CHOKE) and the Throttle Control Lever to the far right FAST (RABBIT) (**Figure 10** on page 12) .
2. Grasp the Recoil Starter Handle (**Figure 10** on page 12) and **slowly pull until you feel resistance**, then pull the cord with a **smooth accelerating motion** to start the Engine. Do not let the Starter Handle snap back against the Engine. One or two pulls usually starts the DR ROTO-HOG Power Tiller.

! WARNING!

- The design of this machine is for tilling soil. Never use this machine for any other purpose as it could cause serious injury.
- Contact with internal rotating parts will cause serious personal injury. Never put hands, face, feet, or clothing under or near the debris shield with the engine running.
- Before performing any maintenance procedure or inspection, stop the engine and wait five (5) minutes to allow all parts to stop and cool. Disconnect the spark plug wire keeping it away from the spark plug.
- Inspect the area where you will be working. The site must be free of potentially hazardous obstacles such as glass, large stones, sticks, wire, rope, and string-like materials. Make sure there are no people or animals in the area around the DR ROTO-HOG power tiller.

! CAUTION!

Remove all long vegetation from this site. Long vegetation will wrap around the tines and cause poor performance.

Operator Controls

The Operator's Position is from the seat of the Tow Vehicle. See Figure 13 for the Operator's controls.

Before Starting the Engine

1. Raise the Tines and place the machine on level ground.
2. Check the Engine oil level every time you use the machine (**Figure 10** on page 12).

3. After the Engine starts, slowly push the Choke Control Lever to the left (RUN) (**Figure 10** on page 12). Wait until the Engine runs smoothly before each Choke adjustment. For the best Engine performance, you should operate the Engine with the Throttle in the Fast (RABBIT) position (**Figure 10** on page 12).

Electric Starting

1. When starting a cold Engine, push the Choke Control Lever to the far right (CHOKE) and the Throttle Control Lever to the far right FAST (RABBIT). (**Figure 10** on page 12).
2. Turn the Key (**Figure 14**) all the way clockwise until the Engine starts, then release. The Key will snap back to the RUN position and the Engine will continue to run.
3. After the Engine starts, slowly push the Choke Control Lever to the left (RUN) position (**Figure 10** on page 12). Wait until the Engine runs smoothly before each Choke adjustment. For optimum performance of the DR ROTO-HOG Power Tiller, you should operate the Engine with the Throttle in the Fast (RABBIT) position (**Figure 10** on page 12).

Stopping the Engine

Manual Start model: Move the Throttle (**Figure 10** on page 12) all the way back to the STOP position.

Electric-Start model: Move the Throttle (**Figure 10** on page 12) all the way back to the STOP position, or; move the Throttle to the SLOW (Turtle) position and turn the Key to OFF.

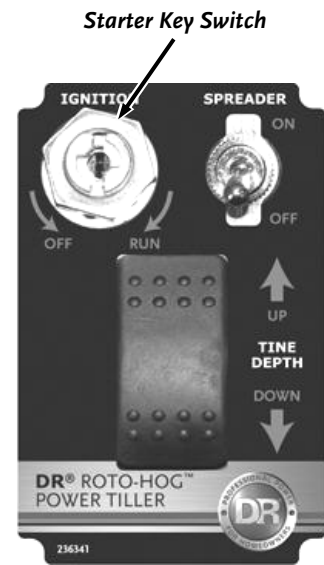

Figure 14

NOTICE!

Never stop the engine by moving the choke lever to the choke position. This could cause an engine backfire resulting in engine damage.

Operating Safety

WARNING!

- Be thoroughly familiar with the controls and the proper use of your DR ROTO-HOG power tiller before using. Never allow anyone to operate the DR ROTO-HOG power tiller without first reading and understanding all instructions in this manual.
- Engage the tines in the air without contacting the soil. Slowly lower the tines into the soil while seated on the tow vehicle. Engaging the tines with them in the soil may cause the Roto Hog to push the tow vehicle forward.
- The first pass on unknown soil conditions should be only about an inch to test the soil conditions.
- Never allow people or pets to ride on this machine.
- Always check for objects and obstacles in the path of this machine before moving.
- Always wear protective goggles or safety glasses with side shields to protect your eyes from possible objects thrown from this machine.
- Do not wear loose clothing or jewelry, which can catch on the machine's moving parts.
- We recommend wearing long pants and gloves while using this machine. Be sure the gloves fit properly and do not have loose cuffs or drawstrings.
- We recommend wearing safety shoes when using this machine. Wear shoes with non-slip treads to improve footing on slippery surfaces. Do not use the machine wearing open sandals or while barefoot.
- We recommend the use of ear protectors or ear plugs rated for at least 20 dba to protect your hearing.
- Never put your hands near the tines to clear debris while the engine is running. Always shut off the DR ROTO-HOG power tiller engine and disconnect the spark plug wire before clearing debris.
- Do not refuel the engine while it is hot or running.

! NOTICE!

Use common sense when using the machine. Learn to recognize the change in sounds when it is overloaded. Turn off the engine immediately if the machine becomes jammed to prevent damage to the drive system.

Understanding the Control Box

The Control Box contains a 3-position momentary Rocker Switch. The “Raise” position raises the Tines (lowers the Wheels). The “Lower” position lowers the Tines (raises the Wheels). When you release the Switch, it will return to center or OFF position (**Figure 15**). The Control Box also contains the Engine Electric-Start Key Switch for the Electric-Start model and the Optional Spreader ON-OFF Switch.

Operating Parameters

The DR ROTO-HOG Power Tiller is designed to be used with most ATVs, Lawn\Garden Tractors, and Compact Tractors. The DR ROTO-HOG Power Tiller should never be used with a Truck (2WD or 4WD). Use of a Truck will void the DR ROTO-HOG Power Tiller Warranty.

Operating Procedures

There are three (3) applications for the DR ROTO-HOG Power Tiller: Garden Tilling, Sod Busting, and small Food Plot installation. For all applications, engage the tines while they are raised and not contacting the soil. Then slowly lower the tines into the soil to the proper depth for the different soil conditions.

Gardens:

1. Check the area for large stones and foreign objects that could snag or wedge into the tines.
2. Perform a soil test to assess needs for soil treatment.

Tip: If a soil test indicates amendments necessary (lime, fertilizers, sulfur, etc) then apply before tilling to best integrate it into the soil. You can apply amendment with the Optional Spreader and incorporate it with the Tiller.

3. Check wetness in the soil to determine if clumping will require slower Tow Vehicle speeds.

Food Plot Installation and Sod Busting:

1. Clear the work area of objects such as glass, large sticks and stones, roots, metal objects, wire, rope, and string-like materials.
2. Cut all vegetation to the lowest possible height.
3. Remove the cut vegetation by either rake, vacuum, blowing OR allow it to dry several days and re-cut.

! CAUTION!

Failure to remove long vegetation will result in frequent stalling of the engine.

NOTE: For information on ordering the optional equipment, visit our web site at www.DRpower.com.

4. Refer to seed specifications to determine the optimal depth of tillage necessary.
5. With initial pass, begin breaking only the top inch of soil to breakup sod.
6. Break the soil thoroughly across the entire area. See “Tilling Tips” on the next page.
7. Gradually lower the Tines 1-2 inches and repeat step 6 until you are satisfied with the tillage created.

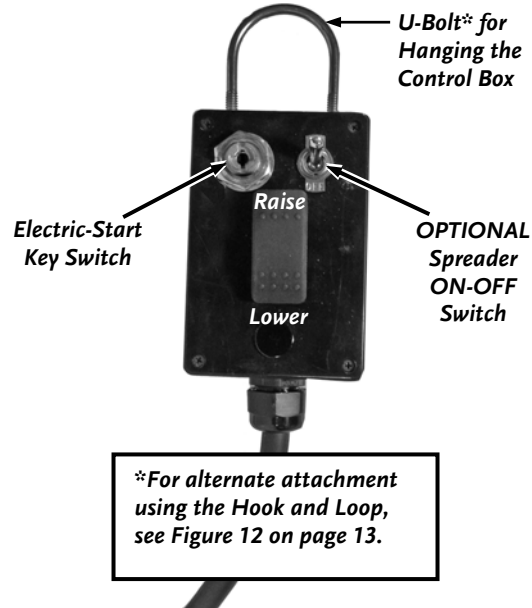

Figure 15

- Using the Optional Spreader, apply seed at a rate specified by the seed manufacturer.

Tilling Tips

- In compacted soil or sod, or in food plot and sod busting applications, several passes may be necessary to till to a depth of seven (7) inches. For the first pass, just scratch the surface. The depth for each successive pass needs to be determined by individual site and soil conditions. If the machine stalls repeatedly, you should till slower or not as deep.
- Check the ground moisture. DO NOT till if you can make a ball of soil in your hand from the ground to be tilled; it is too wet. Create full tillage (depths up to 7") after entire area is dry.
- To obtain the most efficient tillage, operate the DR ROTO-HOG Power Tiller Engine at full throttle at the slowest speed of your Tow Vehicle.
- When operating the machine for the first time, proceed slowly and carefully until you become familiar with the proper method of operating the machine.
- Soil conditions will determine how deep the machine can penetrate on the first pass.
- In damp soil, till only the top inch of seedbed. Allow tillage to dry for several hours in sunny and/or windy conditions.
- Listen to your DR ROTO-HOG Power Tiller Engine. When the Engine RPM decreases or stalls (overloaded condition) raise the Tines for shallower tilling. If the Engine is lightly loaded, lower the Tines to increase the tilling depth.
- If the soil is extremely hard and dry, it may be desirable to "cross till" an area at a shallow depth first, then till the soil in the direction of planting rows on subsequent passes until the desired tillage is obtained.
- Where possible, we recommend that you till in a pattern similar to that shown in Figure 16.

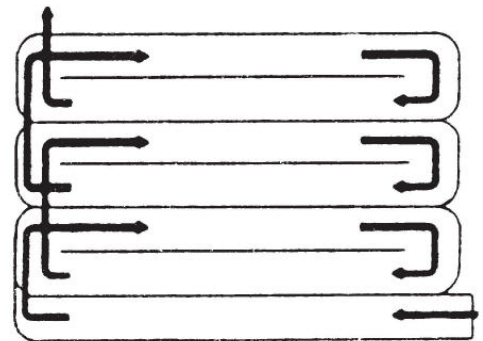

Figure 16

- Make the first pass.

NOTE: If you raise the tines at the end of a pass, use care to lower them back to the same depth. Tilling too deep on the first pass may cause the Tiller to stall or break Shear Pins.

- Skip a space equal to the width of the machine.
- Make the return pass.
- Till the skipped areas.

Cultivating Tips

You can use the DR ROTO-HOG Power Tiller for cultivating (**Figure 17**), which requires a minimum of two (2) inches of soil penetration.

- Set the tines so they will penetrate the soil to a depth of two (2) to three (3) inches.
- Run the DR ROTO-HOG Power Tiller Engine at Full Throttle.

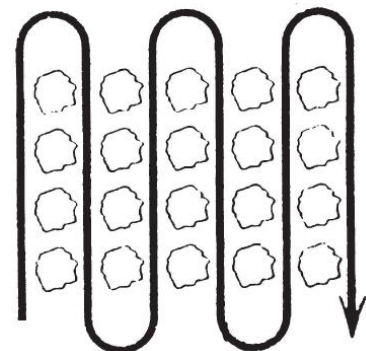

Figure 17

Slopes and Uneven Terrain

WARNING!

- Never operate your DR ROTO-HOG power tiller on slopes greater than 5 degrees. Doing so could result in serious injury or damage to your machine.
 - When operating the machine over uneven terrain and slopes, use extreme caution to not tip over the machine. Move slowly if the ground has ruts, bumps, and other depressions.
-

Handling and Transporting

WARNING!

Never lift the machine while the engine is running.

We recommend using two (2) people to lift the DR ROTO-HOG Power Tiller. Lift the machine by the SMOOTH-TRAK™ Hitch to connect and disconnect from your Tow Vehicle. To transport the machine with your Tow Vehicle, first raise the tines to the MAX position (lower the Wheels) using the Control Box.

NOTICE!

- The DR ROTO HOG power tiller is not equipped for towing on any public roadway.
 - When towed, the maximum safe towing speed is 10 mph.
-

Chapter 4: Maintaining The DR ROTO-HOG Power Tiller

This chapter covers regular maintenance procedures that will ensure the best performance and long life of your DR ROTO-HOG Power Tiller. For Engine maintenance, please refer to the Engine Owner's Manual that came with your machine. Service intervals listed in the checklist below supersede those listed in the Engine Owner's Manual. Maintenance Kits and accessories are available through our website at www.DRPower.com.

WARNING!

When performing any maintenance, you must first shut off the engine, wait five (5) minutes to allow parts to cool and disconnect the spark plug wire, keeping it away from the spark plug.

Regular Maintenance Checklist

NOTE: Consider that the service intervals shown are the maximum under normal operating conditions. Increase frequencies under extremely dirty or dusty conditions.

PROCEDURE	BEFORE EACH USE	EVERY 8-10 HOURS	EVERY 35 HOURS
Check the Engine Oil Level	▲		
Clean the Tines and Debris Shield*	After each use		
Check the general condition of the machine, e.g. nuts, bolts, welds, etc.	▲		
Clean Engine Exterior & Cooling Fins	▲		
Check the Tines Shear Pins for wear	▲		
Grease the Tines Shaft		▲	
Check Battery Voltage		▲	
Clean Air Filter		▲	
Inspect the Tine Drive Belt for wear			▲
Check Tines for Wear			▲
Change Engine Oil NOTE: 1st time 5 hrs.			▲
Replace Air Filter and Pre-cleaner			▲
Replace the Tine Drive Belt			▲
Replace Spark Plug			▲
Grease Wheels			▲

* Cover the Engine Muffler, Carburetor, and Air Filter before using a hose to clean the Tines and Debris Shield. Do not use a power washer; this may force water through the seals of the Actuator.

Lubrication

WARNING!

When performing any maintenance, you must first shut off the engine, wait five (5) minutes to allow parts to cool and disconnect the spark plug wire, keeping it away from the spark plug.

Your DR ROTO-HOG Power Tiller was lubricated at the Factory. However, periodic lubrication of the Engine, Tines Shaft and Wheels is required.

Supplies Needed:

- Grease Gun w/General purpose grease

! WARNING!

Never oil or grease pivot points. Viscous lubricants will attract dust and dirt that can cause wear on pivot points. If you feel you must lubricate them, use only dry powdered graphite type lubricants.

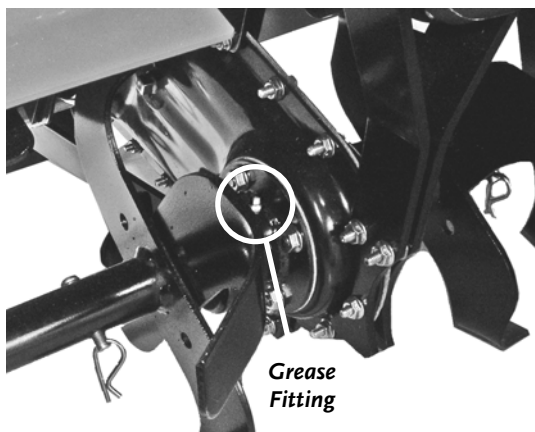

Figure 18

Tines Shaft:

Grease the Tines Shaft using a Grease Gun with General Purpose grease every 8-10 hours. Apply about ten (10) pumps of the grease in the Grease Fitting (**Figure 18**). Perform this lubrication more often in dry and dusty environments.

Wheels:

Grease the Wheels using a Grease Gun with General Purpose grease every 35 hours. Apply the grease to the Grease Fitting on the Wheel Hub just until Grease starts coming out of the Hub (**Figure 9** on page 10). Perform this lubrication more often in dry and dusty environments.

Removing and Replacing the Engine Oil

! WARNING!

When performing any maintenance, you must first shut off the engine, wait five (5) minutes to allow parts to cool and disconnect the spark plug wire, keeping it away from the spark plug.

! NOTICE!

Be certain to fill the engine with oil before starting. See page 12.

Tools & Supplies Recommended:

- Flat Head Screw Driver
- Vacuum Pump Oil Drainer
- SAE 30 High Detergent, 20 oz. (0.60L)

NOTE: Remove the oil when the engine is warm. Warm oil flows quickly and completely.

1. Using a Flat Head Screw Driver, remove the Oil Fill Cap and vacuum the oil from the Engine through the Oil Fill (**Figure 10** on page 12) using a Vacuum Pump Oil Drainer.
2. Replace the oil by following the instructions on page 12.

NOTE: Use SAE 30 High Detergent oil classified "For Service SF, SG, SH, SJ" or higher. Do not use special additives. Other types of oil could cause problems operating your machine. Please refer to your Engine Owner's Manual for detailed oil information.

3. Reattach the Spark Plug wire.

NOTE: Be sure to use environmentally safe disposal procedures for the used oil.

Battery Care

Proper care can extend the life of a Battery. Follow these recommendations to ensure your Battery's best performance and long life:

- Before charging the Battery, observe its external appearance and keep it clean and dry. Never charge or use a Battery that shows cracks, changes shape, leaks, or is otherwise obviously damaged.
- **Do not allow the Battery to run down completely before charging. Leaving the Battery discharged damages the Battery.** If the machine is not used, charge the Battery every 4 to 6 weeks. Operate the Engine for at least 45 minutes to maintain proper Battery charge (Electric Start model only).
- Store an unused Battery in a dry area that does not freeze.
- Do not charge an already charged Battery. In theory, you cannot overcharge our Battery with a trickle charger; however, when a Battery is fully charged and the Charger is still on, it generates heat that could be harmful to the Battery. A fully charged Battery will read 12V-13.2V with a voltmeter.
- Do not continue to crank the Engine, or raise and lower the Tines, when the Battery charge is low.
- If the Battery begins to leak, avoid contact with the leaking acid. Place the damaged Battery in a plastic bag, then dispose of it properly.



If battery acid does contact your skin or eyes, flush with cool water for at least 15 minutes and call a physician. If you ingest acid, call a physician immediately.

Charging the Battery

Operate the Engine for at least 45 minutes to maintain proper Battery charge (Electric Start model only). If the Battery loses its charge, you will need to use a trickle Charger (like the DR Battery Charger) to recharge it. The Charger should have an output of 12 volts at no more than 2 amps.

- At 1 amp, the Battery may need charging for as long as 48 hours.
- At 2 amps, the Battery may need charging for as long as 24 hours.

NOTE: *Using the recoil starter and then running the Engine will not recharge a dead or significantly discharged Battery.*

Charging the Battery is a simple process. Leave the Battery in your DR ROTO-HOG Power Tiller when you charge it.

To connect a Battery Charger to your DR ROTO-HOG Power Tiller, follow the steps listed below.

1. Attach the Black (-) Wire Terminal from the Charger to the (-) terminal of the Battery, then attach the Red (+) Wire Terminal to the (+) Battery terminal.
 2. Plug the Charger into a standard wall outlet.
- Typically, the Battery takes between 6 and 8 hours to fully charge. The Battery does not have a "memory"; so don't worry about overcharging the Battery or charging it too often.
 - You can charge the Battery many times. The Battery lasts longer if you charge it before it is fully drained. Keep it fully charged and at room temperature when not using your DR ROTO-HOG Power Tiller.
 - Once the Battery is charged, pull the plug from the wall outlet and then remove the Charger from your Battery. However, you can leave your Battery plugged in and charging for an extended period.
 - Store the Charger in its self-locking plastic shipping bag. Keep the Charger in a dry location.
 - If the Battery does not hold its charge for very long under normal conditions or it simply won't hold a charge, then replace it. You can purchase replacement Batteries directly from us. To install your new Battery, detach the cables, remove the Battery Clamp, and remove the dead Battery. Next, install the new Battery, replace the Battery Clamp, and attach the cables. Refer to the assembly instructions on page 9 for more details.

! NOTICE!

When the battery gets old and no longer accepts a charge, remove it from your DR ROTO-HOG Power Tiller. Never leave a dead battery in your machine.

Disposing of the Battery Responsibly

The Battery is a sealed lead-acid Battery. Recycle or dispose of it in an environmentally sound way.

- Do not dispose of a lead-acid Battery in a fire, the Battery may explode or leak.
- Do not dispose of a lead-acid Battery in your regular, household trash. Law in most areas prohibits incinerating, disposing in a landfill, or mixing a sealed lead-acid Battery with household trash.

Recycling a Used Battery

! NOTICE!

Please dispose of used batteries responsibly, according to your local hazardous materials regulations. Never throw away used batteries in your household trash.

Please dispose of your used Batteries responsibly by recycling them. Call your local Solid Waste Management District or your local waste handler to locate the collection site nearest you. Some collection sites recycle Batteries year-round; others collect them periodically.

You can also visit the Web site of Earth 911 for more information [www.earth911.org]. Once there, click the Municipal HHW link under Hazardous Household Waste, and enter your zip code. The site lists recycling centers located near you.

For a fee, you can recycle your Batteries with the International Metals Reclamation Company. Visit them at www.inmetco.com and click Services; or contact them at: INMETCO, PO Box 720, 245 Portersville Road, Ellwood City, PA 16117, (724) 758-2825; fax (724) 758-2845

To learn more about hazardous waste recycling, visit the Web site for Battery Council International [www.batterycouncil.org] or for the Environmental Protection Agency [www.epa.gov].

Removing and Replacing the V-Belt

Replace the Tine Drive V-Belt if damaged from slipping under heavy loads or if it shows cracks or frayed edges.

! WARNING!

When performing any maintenance, you must first shut off the engine, wait five (5) minutes to allow parts to cool and disconnect the spark plug wire, keeping it away from the spark plug.

! NOTICE!

Do not move or remove the belt guide (**figure 20**). If you accidentally alter the position of the belt guide, return it to the correct setting of 6-1/4" vertical inches from the fender to the bottom of guide.

Tools and Supplies Needed:

- Screwdriver
- 7/16" Socket

1. Remove the Screw from the top of the Belt Guard (**Figure 19**).
2. Remove the Hex Nut from the rear of the Belt Guard using a 7/16" Socket and remove the Belt Guard.
3. Disengage the Tine Clutch Lever and remove the worn Belt.

Tip: Lifting up on the Clutch Idler Pulley (**Figure 20**) may help in removing the Belt.

4. Reinstall a new Belt, engage the Tine Clutch Lever, and replace the Belt Guard.

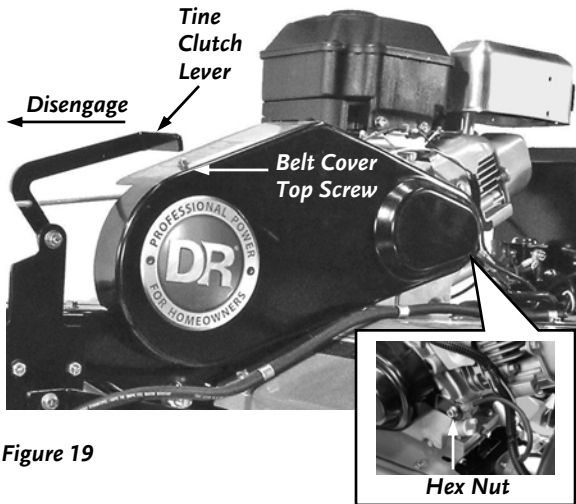

Figure 19

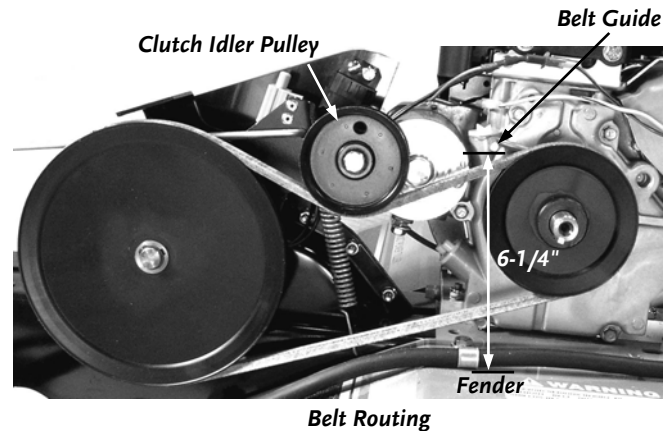

Figure 20

Tine Shear Pins

! WARNING!

When performing any maintenance, you must first shut off the engine, wait five (5) minutes to allow parts to cool and disconnect the spark plug wire, keeping it away from the spark plug.

- The DR ROTO-HOG Power Tiller drive components are protected from damage by Grade 5 Shear Pins in the Tine Assemblies (**Figure 21**). The Shear Pins hold the Tine Assemblies in proper location on the Drive Axles. Should a Tine Assembly strike or pick up a large hidden object and jam, the Shear Pin holding the Tine Assembly to the drive shaft will shear or break, protecting the drive components of the DR ROTO-HOG Power Tiller from major damage.
- Two (2) extra sets of Tine Shear Pins are included with the DR ROTO-HOG Power Tiller.
- The design of the Tine Shear Pin is to loosely fit when properly installed.

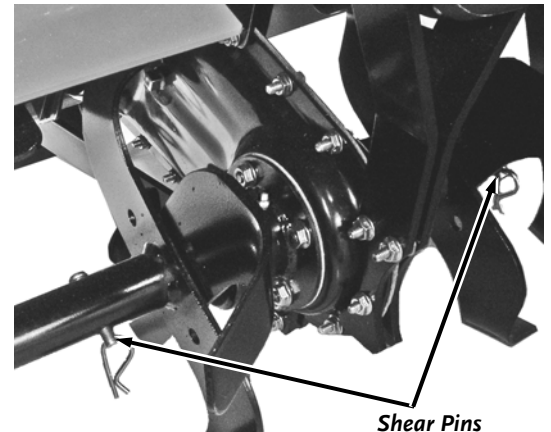

Figure 21

! WARNING!

Never attempt to use a bolt or pin that is larger or harder than the original grade 5 shear pin.

Tine Operation Check

! WARNING!

Before performing this check, you must first shut off the engine, wait five (5) minutes to allow parts to cool and disconnect the spark plug wire, keeping it away from the spark plug.

1. Disengage the Tines and raise them up off the ground using the Control Box.
2. Rotate one set of Tines with your hand; the other set should also rotate.
3. Replace the Spark Plug wire.

Chapter 5: Troubleshooting

Most problems are easy to fix. Consult the Troubleshooting Table for common problems and their solutions. If you continue to experience problems, visit our website at www.DRpower.com or call: 1-800-DR-OWNER (376-9637) for support.

Troubleshooting Table



When performing any maintenance, you must first shut off the engine, wait five (5) minutes to allow parts to cool and disconnect the spark plug wire, keeping it away from the spark plug.

SYMPTOM	POSSIBLE CAUSE
<i>Recoil will not pull out or is difficult to pull.</i>	<ul style="list-style-type: none"> ⇒ Check that the Tine Drive Clutch is disengaged. ⇒ Check the Engine oil level; the Engine may be seized. ⇒ There may be an oil compression lock in the cylinder. Take out the Spark Plug; hold a rag over the Spark Plug hole and pull the Recoil Cord several times to blow out any oil in the Cylinder. Wipe off the Spark Plug and reinstall it. ⇒ The Recoil may be broken or jammed. Visit our website at www.DRpower.com.
<p><i>The Engine will not start manually.</i></p> <p><i>(Please refer to the Engine Owner's Manual for Engine-specific procedures.)</i></p>	<ul style="list-style-type: none"> ⇒ Check that the Tine Drive Clutch is disengaged. ⇒ Check that the Spark Plug Wire is attached. ⇒ Make sure that the Fuel Shut-Off is in the ON position. ⇒ Check the oil and gas level. See page 12. ⇒ The gas may be old; change it if necessary. Use a fuel stabilizer if you keep gas longer than one month. ⇒ Check the Throttle and Choke settings, adjustment and travel. ⇒ The Spark Plug may be dirty or cracked; change it if necessary. If it's oily, leave it out, hold a rag over the Plug Hole and pull the Recoil Cord several times to blow out any oil in the Cylinder, then wipe off the Plug and reinsert it. ⇒ The Air Filter may be dirty; change it following the procedure in the Engine Owner's Manual. ⇒ If your Engine still won't start, visit our website at www.DRpower.com.
<p><i>The Engine will not start using Electric-Start. (Please refer to the Engine Owner's Manual for engine-specific procedures.)</i></p>	<ul style="list-style-type: none"> ⇒ Check all the items under the section called Electric-Starting on page 15. ⇒ Check the previous section on Manual Starting for possible causes. ⇒ Check the In-Line Fuses in front of the Battery (Figure 4 on page 9). ⇒ Check the wire connections, especially the ground connection. This is the large black wire leading from the Battery, and connected to the Engine. ⇒ Check the wire connections to the Solenoid. To avoid sparks, first disconnect the black Battery ground wire. Check to be sure that all of the connections are clean and tight. Reconnect the Battery ground wire. ⇒ Check the ground connection on the Solenoid where it bolts to the Frame. Using a Wrench or Socket, tighten the Bolts to ensure a good connection to the Frame.

! WARNING!

When performing any maintenance, you must first shut off the engine, wait five (5) minutes to allow parts to cool and disconnect the spark plug wire, keeping it away from the spark plug.

SYMPTOM	POSSIBLE CAUSE
<p><i>Continued:</i></p> <p><i>The Engine will not start using Electric-Start. (Please refer to the Engine Owner's Manual for engine-specific procedures.)</i></p>	<p>⇒ The Battery may not be charged. Check the voltage yourself or at a service station. If it is low, charge it with a 12-volt, 1 to 2 Amp trickle charger. If you do not use your machine for at least 45 minutes at a time, the Battery may need to be periodically charged. See the Battery Care section on page 21.</p> <p>⇒ If the Battery is charged and your DR ROTO-HOG Power Tiller still will not start, visit our website at www.DRpower.com.</p>
<p><i>The Engine lacks power or is not running smoothly.</i></p> <p><i>(Please refer to the Engine Owner's Manual for engine-specific procedures.)</i></p>	<p>⇒ Check the Throttle; it should be set in the FAST position.</p> <p>⇒ The Air Filter may be dirty; change it following the procedure in the Engine Owner's Manual.</p> <p>⇒ The Spark Plug may be dirty or cracked; change it if necessary. If it's oily, leave it out, hold a rag over the Plug hole and pull the Recoil Cord several times to blow out any oil in the Cylinder, then wipe off the Plug and reinsert it.</p> <p>⇒ The gas may be old; change it if necessary. Use a fuel stabilizer if you keep gas longer than one month.</p> <p>⇒ The Engine oil may be dirty. Change it if necessary, following the procedure on page 20.</p> <p>⇒ If your Engine still lacks power, visit our website at www.DRpower.com.</p>
<p><i>Engine smokes.</i></p>	<p>⇒ Check the oil level and adjust as needed.</p> <p>⇒ The Air Filter may be dirty; change it following the procedure in the Engine Owner's Manual.</p> <p>⇒ You may be using the wrong oil. Refer to your Engine Owner's Manual for detailed information.</p> <p>⇒ Clean the Engine cooling fins and the carburetor housing if they are dirty.</p> <p>⇒ If the Engine still smokes, visit our website at www.DRpower.com.</p>
<p><i>The Engine runs well but the Tines won't move.</i></p>	<p>⇒ The Tine Drive Clutch is not engaged.</p> <p>⇒ The Tine Drive V-Belt is off the pulleys or broken. See page 22.</p>
<p><i>The Engine runs well but labors when tilling.</i></p>	<p>⇒ Operator is being too aggressive; raise the Tines.</p> <p>⇒ Be sure the Engine Throttle is set on the Fast (RABBIT) position.</p>
<p><i>Excessive bounce and difficult handling.</i></p>	<p>⇒ The area you are tilling may be too dry and hard. Moisten the ground or wait for conditions that are more favorable.</p> <p>⇒ Be sure the Engine Throttle is set on the Fast (RABBIT) position.</p> <p>⇒ If your DR ROTO-HOG Power Tiller still bounces, visit our website at www.DRpower.com.</p>
<p><i>The tilled soil balls up or clumps.</i></p>	<p>⇒ The ground that you are trying to till is too moist. See Tilling Tips on page 17.</p>

Chapter 6: Parts Lists, Schematic Diagrams And Warranty

Parts List - Main Assembly

NOTE: Part numbers listed are available through DR Power Equipment.

Ref#	Part#	Description	Ref#	Part#	Description
01	232971	Pin, Channel Pivot 1/2"	41	233111	Rod, Guide, V-Belt
02	232891	Washer, 1/4" Std .312" x .734"	42	233061	Bolt, Hex, 5/16"-24 x 1" w/Lock
03	233071	Bolt, Hex 5/16"-18 x 3/4" Self	43	232871	Washer, 5/16" Std .375 x .875
04	231251	Fender	44	231231	Rod, Clutch
05	232921	Bolt, Hex 5/16"-18 x 2-1/4", G5	45	231331	Bracket, Idler Arm
06	256631	Bolt, Hex 1/2"-13 x 1-1/2"	46	233561	Bolt, Shoulder, 3/8"-16 x 7/8" W
07	233091	Bolt, Hex 5/8"-11 x 7-1/2", G5	47	233611	Switch, Interlock
08	231221	Chassis, RH	48	233371	Pulley, Idler, 2-3/4"
09	231211	Chassis, LH	49	233131	Rivet, Pop
10	231391	Spacer	50	232821	Bolt, Hex, 3/8"-16 x 1-3/4", G5
11	233311	Nut, Hex, Nylon Lock, 5/8"-11	51	233121	Screw, Washer Head, 1/4"-20 x 1/2"
12	231311	Brace, Front Case	52	224290	Belt Cover, Universal
13	231291	Angle, Reinforcement	53	232720	Spring, Extension
14	233081	Nut, Hex, Nylon Lock, 5/16"-18	54	233581	Key, Woodruff, #61
15	232941	Bolt, Hex, 1/4"-20 x 1", G5	55	233481	Ring, Retaining
16	231281	Cap, Fender End, LH	56	114431	V-Belt, 45"
17	231271	Cap, Fender End, RH	57	233571	Pulley, 8" OD
18	231301	Brace, Rear Case	58.1	231241	Cover, Drive, (Electric Start)
19	233301	Nut, Jam, Hex, 5/16"-24	58.2	231341	Cover, Drive, (Manual Start)
20	233041	Nut, Hex 1/4"-20 w/Lock Washer	59	231351	Guard, Foot
21	231451	Tie, Nylon	60	233261	Engine, B&S 9.00 (Manual Start)
22	233171	Module		233271	Engine, B&S 9.00 (Electric Start)
23	233621	Pin, Clevis, 1/2" x 2"	61	233601	Nut, Hex, Nylon Lock, 3/8"-16
24	233011	Pin, Hair, .08" x 1.58"	62	232911	Nut, Hex, 1/4"-20
25	233211	Assembly, Fender Tube	63	233031	Nut, Hex, Nylon Lock, 1/4"-20
26	233241	Transmission	64	232851	Bolt, Hex, 5/16"-18 x 1", G5
27	231261	Tube, Frame	65	232841	Bolt, Hex, 1/4"-20 x 3/4", G5
28	232961	Bolt, Hex, 5/16"-18 x 2-1/2"	66	232931	Bolt, Slotted, #10-32 x 5/8"
29	233281	Bolt, Hex, 1/4"-20 x 1-1/4", G5	67	233021	Nut, Nylon Lock, #10-32
30	232561	Actuator	68	231481	Screw, Round, #8-32 x 5/8"
31	233321	Pin, Hair, 5/32" x 3"	69	232791	Nut, Nylon, #8-32
32	233181	Assembly, Tongue	70	256641	Nut, Lock, 1/2"-13
33	233001	Pin, Clevis, 3/8" x 4"			
34	232861	Nut, Hex, 5/16"-18, Lock, 3-Way	Safety & Information Labels		
35	233201	Assembly, Hitch Bracket	224531A		Label, Operator
36	232951	Washer, #10	236331		Label, Control Box
37	232660	Clutch Lever	224511		Label, Warning, Avoid Injury
38	233381	Screw, 5/16"-18 x 5/16"	224521		Label, Warning, Keep Away
39	233551	Pulley, 4.5" OD	257261		Label, Warning, Attach Control Cable
40	233361	Key, 3/16" x 1-3/4"			

Schematic Diagram - Main Assembly

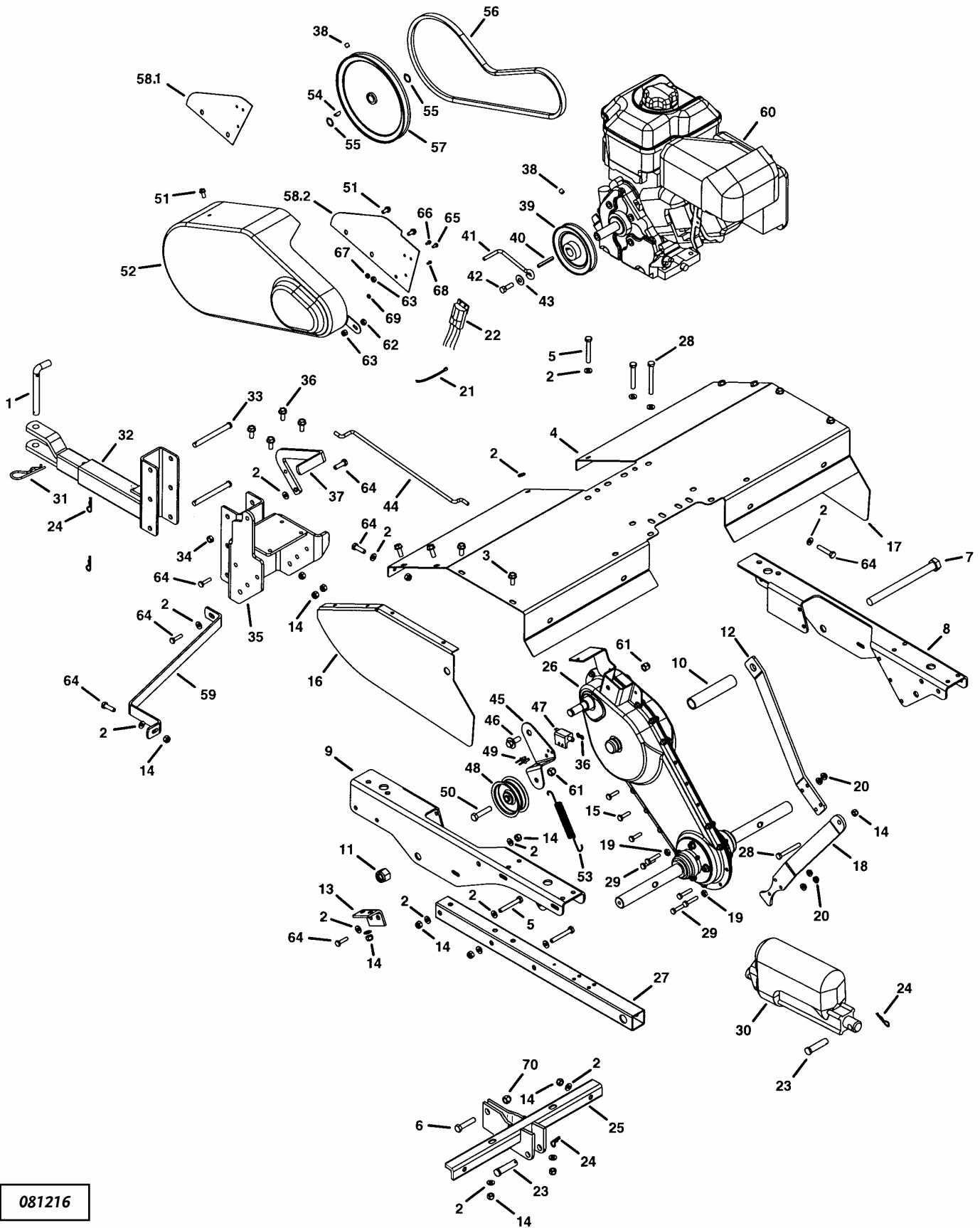

081216

Parts List and Schematic Diagram -Tine Drive Transmission Assembly

NOTE: Part numbers listed are available through DR Power Equipment.

Ref#	Part#	Description	Ref#	Part#	Description
01	233401	Washer, Felt, .985" x 1.515"	14	233441	Assembly, Idler Shaft
02	231381	Cap	15	233461	Assembly, Input Shaft
03	233161	Nut, Hex, 5/16"-18, Flanged Lock	16	233541	Seal
04	256601	Assembly, Flange & Bearing	17	233411	Chain, Roller (Long)
05	233391	Gasket, Flange	18	233521	Assembly, Drive Housing, Side, RH
06	233531	Assembly, Drive Housing, Side, LH	19	233471	Bracket, Belt Guard & Idler
07	233491	Gasket, Drive Housing	20	231421	Bolt, Hex, 1/4"-20 x 5/8" w/Washer
08	233431	Plug, Oil	21	233421	Washer, Thrust, .64" x .9375"
09	233511	Cap, Bearing	22	231371	Tine Assy, RH
10	233501	Bearing, Roller	23	261481	Tine Assy, LH
11	233051	Nut, Hex, 1/4"-20 w/Lock Washer	24	233351	Pin, Clevis, 3/8" x 1-3/4"
12	233251	Assembly, Tine Shaft & Sprocket	25	233591	Pin, Hair, 1/8" x 1-5/8"
13	233451	Chain, Roller (Short)			

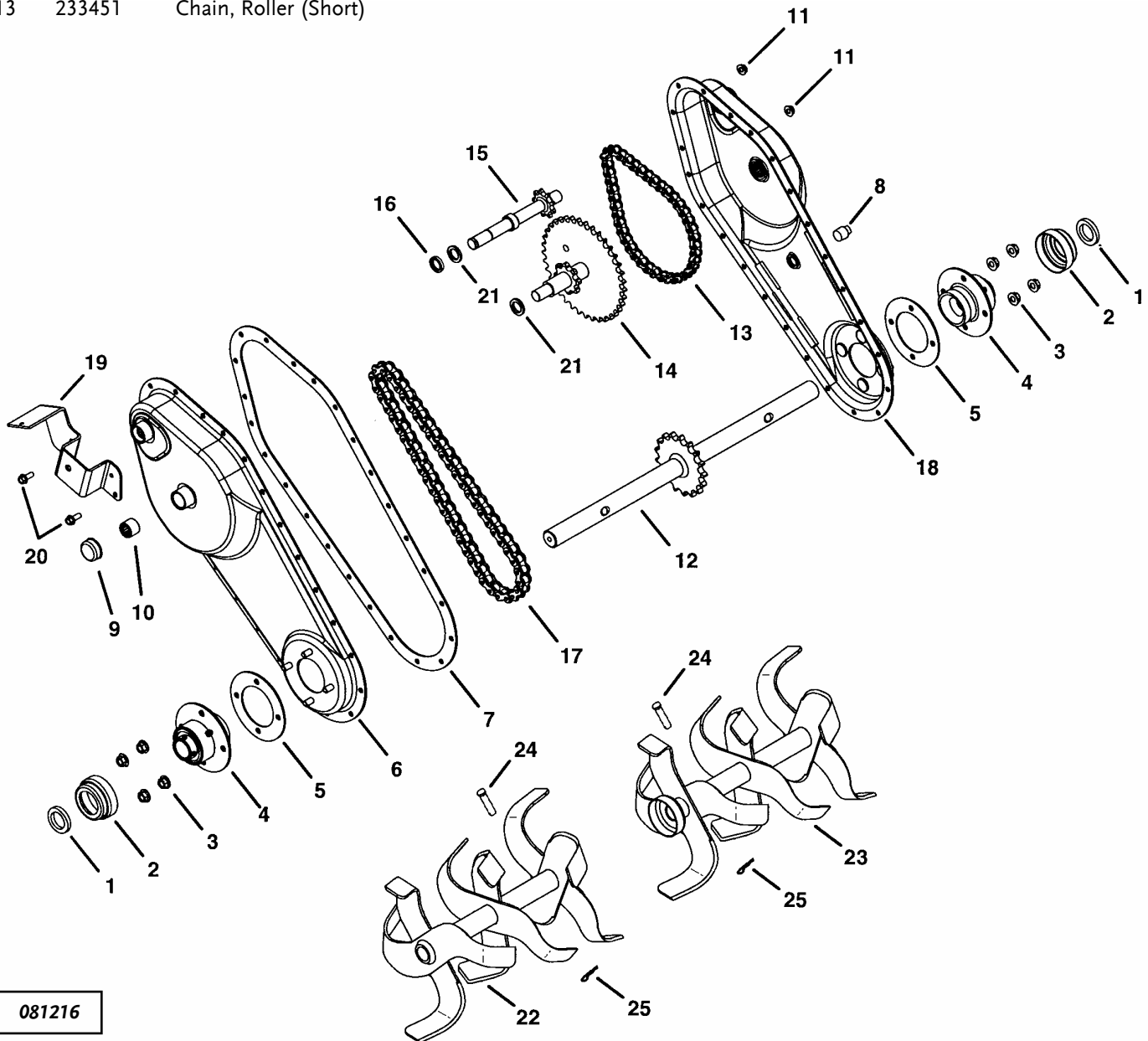

081216

Parts List and Schematic Diagram - Axle Assembly

NOTE: Part numbers listed are available through DR Power Equipment.

Ref#	Part#	Description
01	233041	Nut, Hex 1/4"-20 w/Lock Washer
02	231431	Spacer, 0.266" x 0.625" x 1.5"
03	231401	Bracket, Battery Mounting
04	231441	Bolt, Hex, 1/4"-20 x 3-1/2" GR 5
05	231411	Strap, Battery Hold Down
06	233141	Bolt, Flange Hex, 1/4"-20 X 7-1/2"
07	104831	Battery, 9AH, 12V
08	101551	Solenoid (Electric Start)
09	232981	Pin, 3/16" x 2"
10	232831	Washer, Flat
11	233291	Wheel, 15" x 6-3/4"
12	232901	Pin, 1/8" X 1-1/2"
13	231321	Axle, Pivot
14	233191	Assembly, Wheel Mount
15	233841	Cord Assembly (Manual Start)
	233831	Cord Assembly (Electric Start)
16	125411	Charger, Battery
17	113041	Clips, Alligator
18	231471	Washer, Star
19	232841	Bolt, Hex, 1/4"-20 x 3/4" G5
20	233031	Nut, Hex, Nylock, 1/4"-20
21	232801	Bolt, Nylon (Manual Start)
22	232811	Nut, Nylon (Manual Start)
23	233101	Wire, Engine Ground

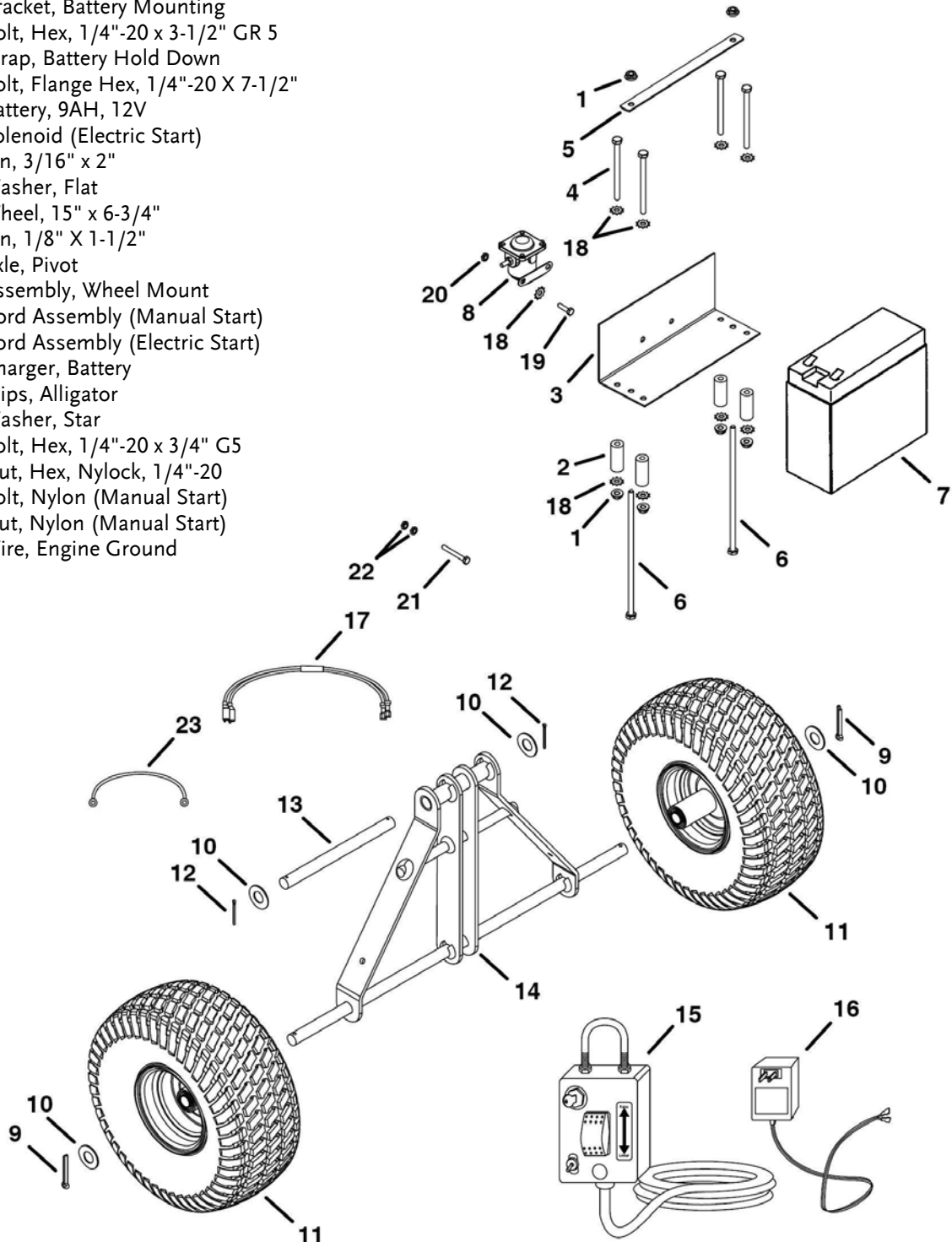

081216

Wiring Diagram - Manual Start model

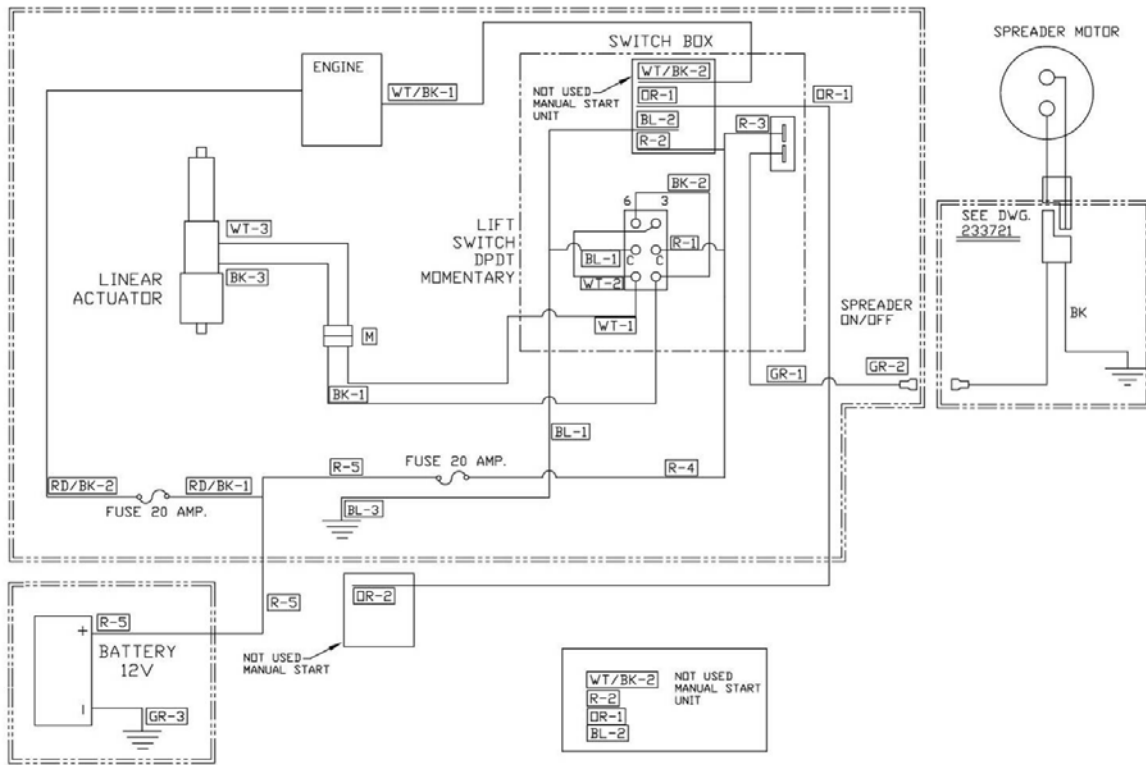

081216

Wiring Diagram - Electric-Start model

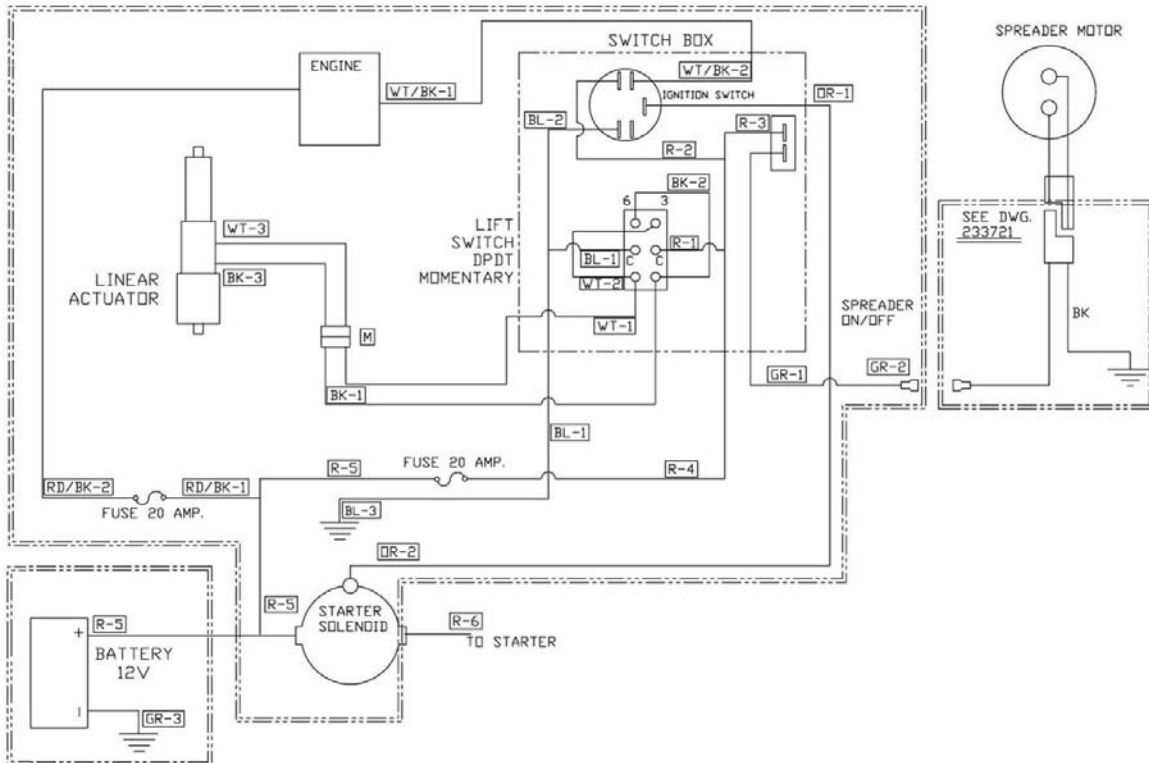

081216

DR[®] ROTO-HOG™ POWER TILLER



2-Year Limited Warranty

Terms and Conditions

The DR[®] ROTO-HOG POWER TILLER is warranted for two (2) years against defects in materials or workmanship when put to ordinary and normal consumer use; ninety (90) days for any other use. The Engine Manufacturer warrants the Engine separately.

For the purposes of all the above warranties, "ordinary and normal consumer use" refers to non-commercial residential use and does not include misuse, accidents, or damage due to inadequate maintenance.

DR[®] Power Equipment certifies that the DR[®] ROTO-HOG POWER TILLER is fit for ordinary purposes for which a product of this type is used. DR[®] Power Equipment however, limits the implied warranties of merchantability and fitness in duration to a period of two (2) years in consumer use, ninety (90) days for any other use.

The 2-Year Limited Warranty on the DR[®] ROTO-HOG POWER TILLER starts on the date the machine ships from our factory. The 2-Year Limited Warranty is applicable only to the original owner.

The warranty holder is responsible for the performance of the required maintenance as defined by the manufacturer's owner manuals. The warranty holder is responsible for replacement of normally wearing parts such as the Drive Belt, Tines, Tires, Air Filter, and Battery. Attachments and accessories to the machine are not covered by this warranty.

During the warranty period, the warranty holder is responsible for the machine transportation charges, if required. During the warranty period, warranty parts will ship by standard method at no charge to the warranty holder. Expedited shipping of warranty parts is the responsibility of the warranty holder.

SOME STATES DO NOT ALLOW LIMITATIONS ON THE LENGTH OF IMPLIED WARRANTIES, SO THE ABOVE LIMITATIONS MAY NOT APPLY TO YOU.

DR[®] Power Equipment shall not be liable under any circumstances for any **incidental or consequential damages or expenses** of any kind, including, but not limited to, cost of equipment rentals, loss of profit, or cost of hiring services to perform tasks normally performed by the DR[®] ROTO-HOG POWER TILLER.

SOME STATES DO NOT ALLOW THE EXCLUSION OR LIMITATION OF INCIDENTAL OR CONSEQUENTIAL DAMAGES, SO THE ABOVE LIMITATIONS MAY NOT APPLY TO YOU.

THIS WARRANTY GIVES YOU SPECIFIC LEGAL RIGHTS, AND YOU HAVE OTHER RIGHTS, WHICH VARY FROM STATE TO STATE.

Daily Checklist for the DR ROTO-HOG Power Tiller

WARNING!

When performing any maintenance, you must first shut off the engine, wait five (5) minutes to allow parts to cool and disconnect the spark plug wire, keeping it away from the spark plug.

To help maintain your DR ROTO-HOG Power Tiller for optimum performance, we recommend you follow this checklist each time you use your machine.

- [] OIL: With the machine on a level surface, remove the Oil Fill Cap and check the oil level.
Fill the reservoir until the oil reaches just below the threads with SAE 30 HD motor oil. See page 12.
- [] GAS: Fill the gas tank with fresh, unleaded gasoline. See page 12.
- [] ENGINE: It is very important to keep the engine clean. Remove dirt and other debris from the Engine Cooling Fins and Debris Shield. A dirty Engine retains heat and can cause damage to internal Engine components.
- [] HARDWARE: Check all nuts and bolts to be sure that the components are secure.
- [] FRAME: Check all welds to be sure that the Frame is intact and secure.
- [] TINES: Make sure that the Tine Assemblies and Debris Shield are free of accumulated debris.

End of Season and Storage

WARNING!

When performing any maintenance, you must first shut off the engine, wait five (5) minutes to allow parts to cool and disconnect the spark plug wire, keeping it away from the spark plug.

NOTE: Please refer to the Engine Owner's Manual for Engine-specific procedures.

- Change the Engine oil.
- If your DR ROTO-HOG Power Tiller will be idle for more than 30 days, we recommend using a gas stabilizer. This will prevent sediment from gumming up the carburetor. If there is dirt or moisture in the gas or tank, remove it by draining the tank. Completely fill the tank with fresh, unleaded gas and add the appropriate amount of stabilizer or gasoline additive. Run the Engine for a short time to allow the additive to circulate.
- Remove the Spark Plug and pour about 1 ounce of motor oil into the cylinder hole. Replace the Plug and pull the Recoil Starter Rope until you feel strong resistance. This will coat the Piston and seat the Valves to prevent moisture buildup.
- Clean or replace the Engine Air Filter. Reference the Engine Owner's Manual.
- Clean dirt and debris from the Engine Cylinder Head Cooling Fins, Debris Screen, and Muffler.
- Clean out residual debris from the under the Debris Shield and Tine Assemblies.
- Lubricate the Tine Assemblies and Wheels. See page 20.
- Touchup all rusted or chipped paint surfaces. Sand them lightly before painting.
- Be sure all Nuts, Bolts, and Screws are securely fastened.
- Inspect moving parts and the Tine Drive Belt for damage and wear; replace if necessary.
- Store the Battery in a dry area that will not freeze. If you will not use the machine over a long period, charge the battery every four to six weeks. See page 21.
- If possible, store your DR ROTO-HOG Power Tiller inside, but not near an open flame or spark such as found in a water heater.
- After the DR ROTO-HOG Power Tiller has cooled, cover the machine with a suitable protective cover that does not retain moisture. Do not use plastic as this material cannot breathe; it also allows condensation to form, which will cause your machine to rust.



DR® Power Equipment, A division of Country Home Products®

75 MEIGS ROAD, P.O. BOX 25, VERGENNES, VERMONT 05491