



- Ⓒ **GB** *Operating & Maintenance Instructions*
- Ⓒ **BG** *Инструкции за работа и техническо обслужване*
- Ⓒ **CR** *Upute za korištenje i održavanje*
- Ⓒ **CZ** *Návod k obsluze a údržbě*
- Ⓒ **EE** *Kasutus- ja hooldusjuhend*
- Ⓒ **H** *Kezelési és karbantartási útmutató*
- Ⓒ **LT** *Naudojimo ir aptarnavimo instrukcija*
- Ⓒ **LV** *Lietošanas un apkopes instrukcija*
- Ⓒ **PL** *Instrukcja Obsługi i Konserwacji*
- Ⓒ **RO** *Instrucțiuni de utilizare și de întreținere*
- Ⓒ **RU** *Инструкции по эксплуатации и техническому обслуживанию*
- Ⓒ **SL** *Navodila za uporabo & vzdrževanje*



Model 100000

DOV
Extended Life Series

Series 700



Fig. 1

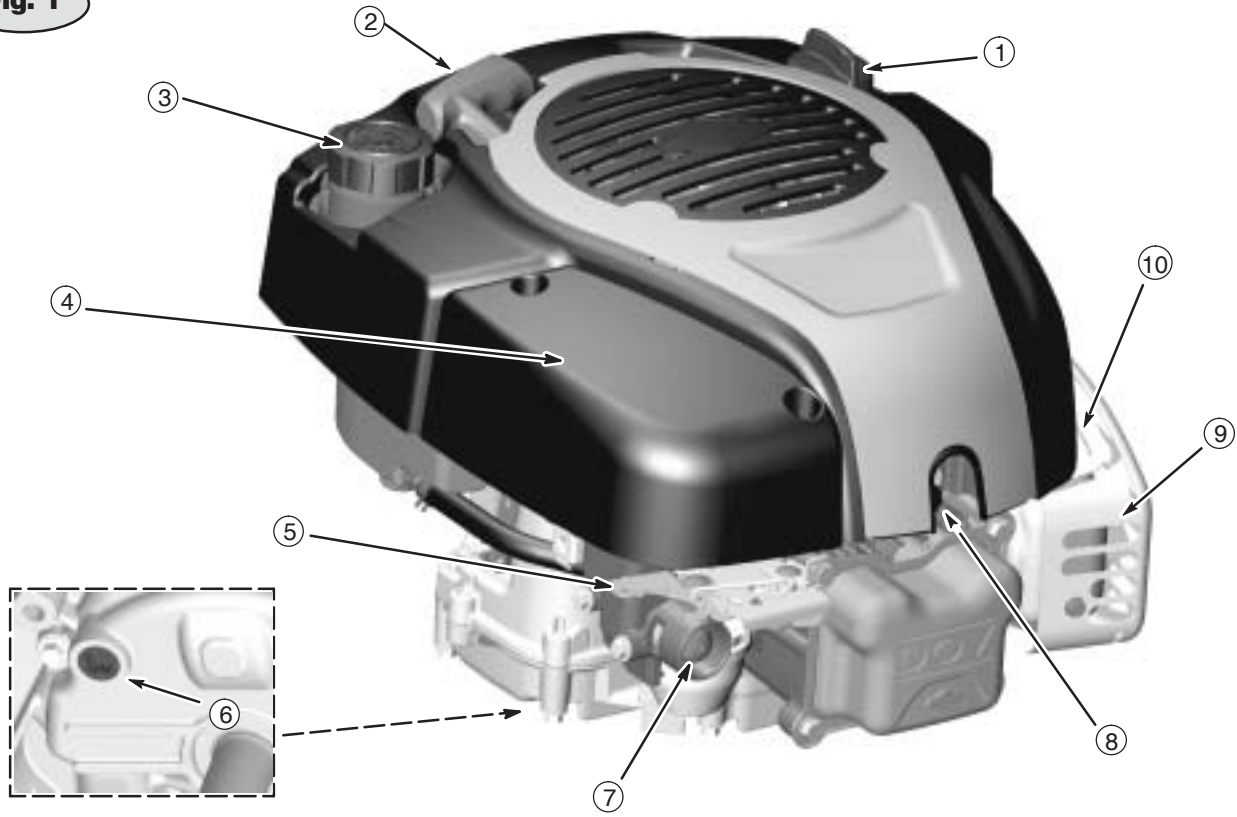

Fig. 2

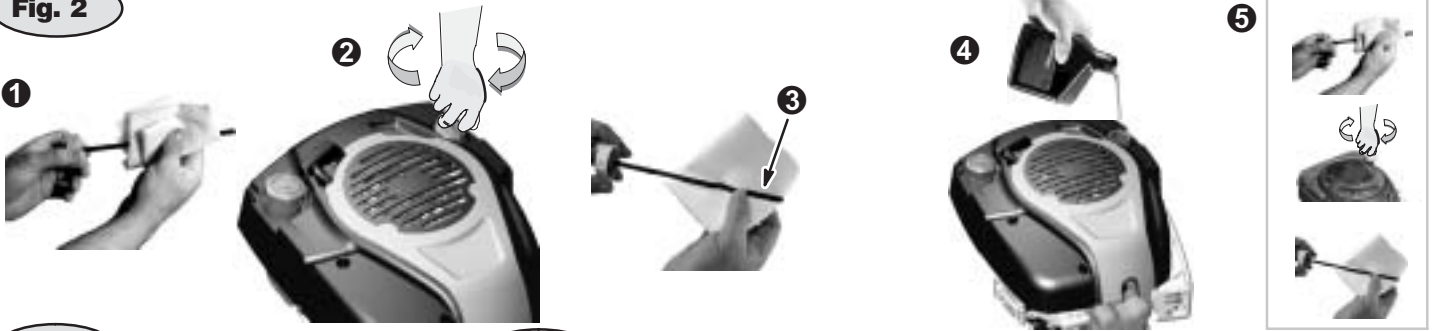

Fig. 3

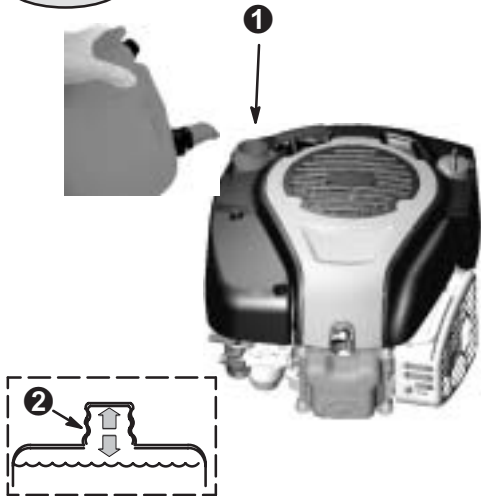

Fig. 4



Note: (This note applies only to engines used in the U.S.A.) Maintenance, replacement or repair of the emission control devices and systems may be performed by any nonroad engine repair establishment or individual. However, to obtain no charge repairs under the terms and provisions of the Briggs & Stratton warranty statement, any service or emission control part repair or replacement must be performed by a factory authorized dealer.



ENGINE COMPONENTS

Fig. 1

- ① Oil fill and dipstick
- ② Rewind rope handle
- ③ Fuel fill cap
- ④ Air cleaner
- ⑤ Speed control lever, if equipped
- ⑥ Oil drain plug (located at the bottom of engine)
- ⑦ Primer bulb
- ⑧ Spark plug
- ⑨ Muffler
- ⑩ Engine Model / Type / Code number

Record your engine Model, Type and Code numbers here for future use.



Record your date of purchase here for future use.

GENERAL INFORMATION

In the state of California, the Model 100000 engines covered in this manual are certified by the California Air Resources Board to meet emissions standards for 125 hours. Such certification does not grant the purchaser, owner or operator of this engine any additional warranties with respect to the performance or operational life of this engine. This engine is warranted solely according to the product and emissions warranties stated elsewhere in this manual.

Note: For practical operation, the horsepower loading should not exceed 85% of rated horsepower. Engine power will decrease 3-1/2% for each 1,000 feet (300 meters) above sea level and 1% for each 10° F (5.6° C) above 77° F (25° C). It will operate satisfactorily at an angle up to 15°. Refer to the equipment operator manual for safe allowable operating limits on slopes.

SAFETY SPECIFICATIONS

  This manual contains safety information to make you aware of the hazards and risks associated with engines, and how to avoid them. Because Briggs & Stratton does not necessarily know what equipment this engine will power, it is important that you read and understand these instructions and the instructions for the equipment this engine powers.



















 **WARNING**

The engine exhaust from this product contains chemicals known to the State of California to cause cancer, birth defects, or other reproductive harm.



 **WARNING**

Briggs & Stratton does not approve or authorize the use of these engines on 3-wheel All Terrain Vehicles (ATVs), motor bikes, fun/recreational go-karts, aircraft products or vehicles intended for use in competitive events. Use of these engines in such applications could result in property damage, serious injury (including paralysis), or even death.

Symbols Associated with this Engine

	Fire		Safety Alert		
	Explosion		Read Operator's Manual		
	Kickback		On Off		Stop
	Shock		Oil		Slow
	Hot Surface		Fuel		Fast
	Moving Parts		Open Choke		
	Toxic Fumes		Full / Closed Choke		
	Hazardous Chemical				

A signal word (DANGER, WARNING, or CAUTION) is used with the alert symbol to indicate the likelihood and the potential severity of injury. In addition, a hazard symbol may be used to represent the type of hazard.

-  **DANGER** indicates a hazard which, if not avoided, **will result in death or serious injury.**
 -  **WARNING** indicates a hazard which, if not avoided, **could result in death or serious injury.**
 -  **CAUTION** indicates a hazard which, if not avoided, **might result in minor or moderate injury.**
- CAUTION**, when used **without** the alert symbol, indicates a situation that **could result in damage to the engine.**

 **WARNING**

Engines give off carbon monoxide, an odorless, colorless, poison gas. Breathing carbon monoxide can cause nausea, fainting or death.

- Start and run engine outdoors.
- Do not start or run engine in enclosed area, even if doors or windows are open.

 **WARNING**

Starting engine creates sparking. Sparking can ignite nearby flammable gases. Explosion and fire could result.

- If there is natural or LP gas leakage in area, do not start engine.
- Do not use pressurized starting fluids because vapors are flammable.



WARNING

Gasoline and its vapors are extremely flammable and explosive. Fire or explosion can cause severe burns or death.

WHEN ADDING FUEL

- Turn engine OFF and let engine cool at least 2 minutes before removing gas cap.
- Fill fuel tank outdoors or in well-ventilated area.
- Do not overfill fuel tank.
- Keep gasoline away from sparks, open flames, pilot lights, heat, and other ignition sources.
- Check fuel lines, tank, cap, and fittings frequently for cracks or leaks. Replace if necessary.

WHEN STARTING ENGINE

- Make sure spark plug, muffler, fuel cap and air cleaner are in place.
- Do not crank engine with spark plug removed.
- If fuel spills, wait until it evaporates before starting engine.
- If engine floods, set choke to OPEN/RUN position, place throttle in FAST and crank until engine starts.

WHEN OPERATING EQUIPMENT

- Do not choke carburetor to stop engine.

WHEN TRANSPORTING EQUIPMENT

- Transport with fuel tank EMPTY.

WHEN STORING GASOLINE OR EQUIPMENT WITH FUEL IN TANK

- Store away from furnaces, stoves, water heaters or other appliances that have pilot light or other ignition source because they can ignite gasoline vapors.



WARNING

Running engines produce heat. Engine parts, especially muffler, become extremely hot.

Severe thermal burns can occur on contact.

Combustible debris, such as leaves, grass, brush, etc. can catch fire.

- Allow muffler, engine cylinder and fins to cool before touching.
- Remove accumulated combustibles from muffler area and cylinder area.
- Install and maintain in working order a spark arrester before using equipment on forest-covered, grass-covered, brush-covered unimproved land. The state of California requires this (Section 4442 of the California Public Resources Code). Other states may have similar laws. Federal laws apply on federal land.

OIL RECOMMENDATIONS

CAUTION:

Engine shipped from Briggs & Stratton without oil. Before starting engine, fill with oil. Do not over-fill.

- Use a high quality motor oil.
- Do not use special additives. **Do not mix oil with gasoline.**
- Choose a viscosity according to average temperature such as SAE 30 weight oil, see chart below.

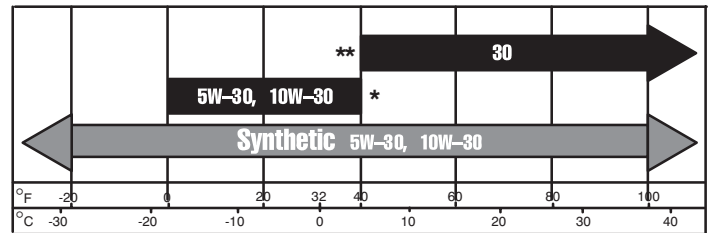

CAUTION:

- * Air cooled engines run hotter than automotive engines. The use of non-synthetic multi-viscosity oils (5W-30, 10W-30, etc.) in temperatures above 40° F (4° C) will result in higher than normal oil consumption. When using a multi-viscosity oil, check oil level more frequently.
- ** 30 weight oil, if used below 40° F (4° C), will result in hard starting and possible engine bore damage due to inadequate lubrication.

OIL CAPACITY

- Engine holds approximately 0.61 liter (20 oz).

OIL PROCEDURE

Fig. 2

- Check oil level before every use and after every eight (8) hours of continual use.
 1. Place engine level and clean around oil fill .
 2. Remove dipstick, wipe with clean cloth ❶, insert and tighten down again ❷. Remove dipstick and check oil level. Oil should be at FULL mark ❸. If oil is required, add slowly ❹. Recheck oil level on dipstick ❺.
 3. **Do not over fill.** Overfilling with oil may cause smoking, hard starting, spark plug fouling, and oil saturation of air filter. Drain out excess, if oil level is over FULL mark on dipstick.
 4. Tighten dipstick firmly before starting engine.

FUEL RECOMMENDATIONS

Use clean, fresh, **lead-free** gasoline with a minimum of 85 octane. Leaded gasoline may be used if it is commercially available and if unleaded is unavailable.

In U.S.A. leaded gasoline may not be used. Some fuels, called oxygenated or reformulated gasolines, are gasolines blended with alcohols or ethers. Excessive amounts of these blends can damage the fuel system or cause performance problems. If any undesirable operating symptoms occur, use gasoline with a lower percentage of alcohol or ether.

This engine is certified to operate on gasoline. Exhaust Emission Control System: EM (Engine Modifications).

Do not use gasoline which contains Methanol. **Do not mix oil with gasoline.**

WARNING

Before refueling, allow engine to cool 2 minutes.

Fig. 3

ADDING FUEL

Clean around fuel fill ❶ before removing cap. Fill tank to approximately 1 inch below top of neck ❷ to allow for fuel expansion. Be careful not to overfill.



WARNING

Rapid retraction of starter cord (kickback) will pull hand and arm toward engine faster than you can let go.

Broken bones, fractures, bruises or sprains could result.

- When starting engine, pull cord slowly until resistance is felt, then pull rapidly.
- Direct coupled equipment components such as, but not limited to, blades, impellers, pulleys, sprockets, etc., must be securely attached.



WARNING

Rotating parts can contact or entangle hands, feet, hair, clothing, or accessories.

Traumatic amputation or severe laceration can result.

- Operate equipment with guards in place.
- Keep hands and feet away from rotating parts.
- Tie up long hair and remove jewelry.
- Do not wear loose-fitting clothing, dangling drawstrings or items that could become caught.



WARNING

Unintentional sparking can result in fire or electric shock.

Unintentional start-up can result in entanglement, traumatic amputation, or laceration.

BEFORE PERFORMING ADJUSTMENTS OR REPAIRS

- Disconnect spark plug wire and keep it away from spark plug.

WHEN TESTING FOR SPARK

- Use approved spark plug tester.
- Do not check for spark with spark plug removed.



Fresh Start® FUEL CAP

Fig. 4



Your engine may be equipped with a Fresh Start fuel cap ❶.

Fresh Start fuel cap is designed to hold a cartridge ❷ which contains fuel stabilizer. Fuel stabilizer is essential in engines stored over 30 days to prevent gum from forming in fuel system or on essential carburetor parts.

1. Place silver foil seal end of cartridge into fuel cap. ❸
2. Press to “snap” cartridge into place. ❹
3. Remove the white tab to expose membrane. ❺
4. Reinstall fuel cap on engine fuel tank. ❻
5. Check periodically - if empty, remove and replace.
6. Store unopened cartridges in a cool, dry, well-ventilated area. Keep open cartridge in fuel cap, and fuel cap closed on fuel tank when not in use.

	⚠ DANGER
	Fresh Start® fuel cap cartridge contents are HARMFUL OR FATAL IF SWALLOWED.
	Avoid contact to eyes, skin, or clothing. Do not take internally. Avoid breathing the mist or vapor. Overexposure to eyes or skin can cause irritation.
	KEEP STABILIZER OUT OF THE REACH OF CHILDREN. Fuel stabilizer is a hazardous chemical.**
	<ul style="list-style-type: none">• IF SWALLOWED, call physician immediately. Do not induce vomiting. If inhaled, remove to fresh air. In case of eye or skin contact, flush with water for 15 minutes.• Store unopened cartridges in a cool, dry, well-ventilated area. Keep open cartridge in fuel cap, and fuel cap closed on fuel tank when not in use.
	<i>In case of emergency, contact a physician immediately and call 1-800-424-9300 for material safety information.</i>
	** Fuel stabilizer contains: 2,6-di-tert-butylphenol (128-39-2) and aliphatic petroleum distillate (64742-47-8).

BEFORE STARTING

	⚠ WARNING
	Always keep hands and feet clear of equipment moving parts.
	⚠ WARNING
	Do not use a pressurized starting fluid. Vapors are flammable.

- Start, store and fuel equipment in level position.
- Check oil level.

Engine models vary. There are three variations to choose before starting your engine. How your engine is equipped will determine which steps to follow. The variations are ReadyStart where the engine has only a throttle control, Primer equipped which means your engine does not have a choke control, and Standard starting where your engine is equipped with both primer and choke control. Know your engine before starting.

READY START EQUIPPED ENGINES

Fig. 5

1. Move throttle control to FAST ❶ position. (if equipped)
2. See STARTING section.

PRIMER EQUIPPED ENGINE

1. Move throttle control to FAST ❶ position.
2. Locate the primer bulb ❷ and push firmly 5 times the FIRST TIME you start a new engine. For all future starts push primer bulb 3 times. Pressing the primer too many times can flood the engine with fuel, and the engine may not start.

Note: If engine stopped because it ran out of fuel, refuel engine and push primer bulb 3 times. Priming is usually unnecessary when restarting a warm engine. However, cool weather may require priming to be repeated.

3. See STARTING section.

STANDARD ENGINE

Fig. 6

1. Open fuel shut-off valve 1/4 turn, if equipped. ❶
2. Move throttle control to FAST or START position, if equipped. ❷
3. Move choke to RUN position, if equipment has this control.

4. Locate the primer bulb ❸ and push firmly 5 times the FIRST TIME you start a new engine. For all future starts push primer bulb 3 times. Pressing the primer too many times can flood the engine with fuel, and the engine may not start.

Note: If engine stopped because it ran out of fuel, refuel engine and push primer bulb 3 times. Priming is usually unnecessary when restarting a warm engine. However, cool weather may require priming to be repeated.

5. See STARTING section.

STARTING

Fig. 7

REWIND STARTER

1. Close safety brake control handle ❶ on equipment with this feature. Slowly pull cord ❷ until you feel resistance, then pull quickly. Repeat if necessary. When engine starts, operate with throttle in FAST position.
2. If engine does not start after 3 pulls, push primer bulb 3 times and pull starter again.
3. Repeat if necessary with choke (if equipped) in RUN position and throttle in FAST.
4. When engine starts, operate in FAST position.

ELECTRIC START, IF EQUIPPED

1. If equipment manufacturer has supplied battery, charge it before trying to start engine, as equipment manufacturer recommends.
2. Turn key to START.
3. Repeat if necessary with choke (if equipped) in RUN position and throttle in FAST.
4. When engine starts, operate in FAST position.

Note: Use short starting cycles (15 seconds/ minute) to prolong starter life. Extended cranking can damage starter motor.

STOPPING

Engine models vary. If equipped, follow one or more of the steps listed.

1. Release safety brake control handle.
2. Move throttle control to STOP.
3. Push stop switch to OFF.
4. Close fuel shut-off valve.

CAUTION: DO NOT move choke control to CHOKE position to stop engine. Backfire or engine damage may occur.

MAINTENANCE

Fig. 8

Regular maintenance improves performance and extends engine life. More frequent service is required when operating in adverse conditions.

	⚠ WARNING
	To prevent accidental starting, remove spark plug wire ❶ and keep it away from spark plug before servicing. Do not strike the flywheel with hammer or hard object. If done, the flywheel may shatter during operation. Do not tamper with links or other parts to increase engine speed.

⚠ CAUTION
If engine must be tipped to transport equipment or to inspect or remove grass, keep spark plug side of engine UP ❷ . Start, store and fuel equipment in level position.

Follow the hourly or calendar intervals, whichever occur first. More frequent service is required when operating in adverse conditions noted below.

First 5 Hours

- Change oil

Every 5 Hours or Daily

- Check oil level
- Clean around muffler
- Clean around finger guard

Every 25 Hours or Every Season

- Change oil if operating under heavy load or high ambient temperature
- Service air cleaner Oil Foam element *

Every 50 Hours or Every Season

- Change oil
- Inspect spark arrester, if equipped

Every 100 Hours or Every Season

- Replace spark plug
- Clean cooling system*

* Clean more often under dusty conditions, or when airborne debris is present or after prolonged operation cutting tall, dry grass.

CHANGING OIL

Fig. 9

Change oil after first 5 hours of operation, then every 50 hours or every season. Change oil every 25 hours when operating the engine under heavy load or in high temperatures. Change oil while engine is warm.



WARNING
Before tipping engine or equipment to drain oil, drain fuel from tank by running engine until fuel tank is empty.

1. Run engine until it runs out of fuel. Otherwise, fuel can leak out, creating a fire/explosion hazard, when you tip engine in Step 4.
 2. With engine OFF but still warm remove dipstick.
 3. Top oil drain: ❶ Keep spark plug side up. On bottom oil drain: By removing drain plug ❷ with a ratchet and square extension ❸, oil can be drained from engine bottom. ❹ Replace drain plug.
- Note:** Top oil drain is recommended method, however oil can drain from bottom as shown.
4. Place engine level. Add new oil. Oil capacity of engine is approximately 0.61l (20 oz). Fill to FULL mark on dipstick. DO NOT OVERFILL. Replace dipstick.
 5. Reconnect spark plug wire before starting.

CAUTION: Used oil is a hazardous waste product. Dispose of used oil properly.

AIR CLEANER MAINTENANCE

Fig. 10

All engines have an air cleaner cartridge. Check and clean the cartridge after every 25 hours of use, more often under dusty conditions. Replace the cartridge after every 100 hours of use or before each season.

1. Loosen screws and lift cover off. ❶
2. Carefully remove air cleaner cartridge ❷, preventing debris from falling into carburetor area ❹ or air vent opening ❸.
3. Do not use water or solvents to clean cartridge. Simply tap gently to release loose dirt from cartridge. Replace if worn or very dirty.

CAUTION: Do not use pressurized air or solvents to clean cartridge. Pressurized air will damage cartridge, solvents will dissolve cartridge.

4. Install new or cleaned filter with the bottom cartridge sealing air vent on base. Replace cover onto base, and tighten screws.

SPARK PLUG MAINTENANCE

Fig. 11

Check the spark plug every 100 hours or every season, whichever occurs first. Replace the spark plug if upon inspection the electrodes ❶ are burned or worn. Ensure the spark plug is clean. Check the gap ❷ with a feeler gage ❸ and reset to 0.51mm or 0.020 in. if necessary.

Note: In some areas, local law requires using a resistor spark plug to suppress ignition signals. If this engine was originally equipped with resistor spark plug, use same type of spark plug for replacement.

WARNING

DO NOT attempt to start engine with spark plug removed. Fuel can ignite and cause a fire or explosion.

CLEANING DEBRIS

Fig. 12

Daily or before every use, clean grass, chaff, or accumulated debris from engine. Keep linkage, s-ring and controls clean. Keep area around and behind muffler free of any combustible debris. Remove spark arrester. Keeping engine clean allows air movement around engine.

Do not spray engine with water to clean because water could contaminate fuel. Clean with a brush or compressed air.

Clean cooling system

To prevent overheating and engine damage, we recommend that you have an authorized Briggs & Stratton Service dealer clean the air cooling system per the maintenance intervals.

STORAGE

Engines stored over 30 days need to be protected or drained of fuel to prevent gum from forming in fuel system or on essential carburetor parts. For engine protection, use a Fresh Start fuel cap. Fuel containers for storage use Fuel Stabilizer. Fresh Start fuel cap cartridge has enough stabilizer to keep fuel fresh up to 6 months.

If stabilizer is not used or if engine is operating on gasoline containing alcohol, e.g. gasohol, remove all fuel from tank and run engine until it stops from lack of fuel.

1. Change oil.
2. Remove spark plug and pour about 15 ml (1/2 oz) of engine oil into cylinder. Replace spark plug and crank slowly to distribute oil.
3. Clean chaff and debris from cylinder and cylinder head fins, under finger guard and behind muffler.
4. When removing the unit from storage, only use fresh gasoline. Perform operation checks, see maintenance schedule, before starting engine.

SERVICE

See an Authorized Briggs & Stratton Service Dealer. Each one carries a stock of Genuine Briggs & Stratton Parts and is equipped with special service tools.

Need Assistance? Go to the website or call, 1-800-233-3723, (U.S.A. and Canada) to hear a menu of pre-recorded messages offering engine maintenance information.

Air cleaner cartridge	792038
Oil	100005 -or- 100028
Fuel stabilizer (4.2 oz., 125 ml bottle)	5041
Standard spark plug	692051
Spark tester	19368
Spark plug wrench	89838 (5023)
Oil pump kit	5056

(uses standard electric drill to remove oil from engine quickly)

To purchase, or view other products Briggs & Stratton has available, see an Authorized Briggs & Stratton Service Dealer. Use our web site at www.briggsandstratton.com to find a dealer nearest you, or check the "Yellow Pages™".



Walking fingers logo and "Yellow Pages" are registered trademarks in various jurisdictions.

Insist on Genuine Briggs & Stratton replacement parts with our logo on the box and/or part. Non-original parts may not perform as well and may void your warranty.

TUNE-UP SPECIFICATIONS

Armature air gap	0.15 - 0.35 mm (0.006 - 0.014 in.)
Spark plug gap	0.51 mm (0.020 in.)
Model 100000	
Bore	64.00 mm (2.52 in.)
Stroke	49.99 mm (1.968 in.)
Displacement	161 cc (9.82 cu in.)

Note: For practical operation, the horsepower loading should not exceed 85% of rated horsepower. Engine power will decrease 3-1/2% for each 1,000 feet (300 meters) above sea level and 1% for each 105 F (5.65 C) above 775 F (255 C). It will operate satisfactorily at an angle up to 155. Refer to the equipment operator manual for safe allowable operating limits on slopes.

**Briggs & Stratton Corporation (B&S),
the California Air Resources Board (CARB)
and the United States
Environmental Protection Agency (U.S. EPA)
Emissions Control System Warranty Statement
(Owner's Defect Warranty Rights and Obligations)**

California, United States and Canada Emissions Control Defects Warranty Statement

The California Air Resources Board (CARB), U.S. EPA and B&S are pleased to explain the Emissions Control System Warranty on your small off-road engine (SORE). In California, new small off-road engines model year 2006 and later must be designed, built and equipped to meet the State's stringent anti-smog standards. Elsewhere in the United States, new non-road, spark-ignition engines certified for model year 1997 and later must meet similar standards set forth by the U.S. EPA. B&S must warrant the emissions control system on your engine for the periods of time listed below, provided there has been no abuse, neglect or improper maintenance of your small off-road engine. Your emissions control system includes parts such as the carburetor, air cleaner, ignition system, fuel line, muffler and catalytic converter. Also included may be connectors and other emissions related assemblies. Where a warrantable condition exists, B&S will repair your small off-road engine at no cost to you including diagnosis, parts and labor.

Briggs & Stratton Emissions Control Defects Warranty Coverage

Small off-road engines are warranted relative to emissions control parts defects for a period of two years, subject to provisions set forth below. If any covered part on your engine is defective, the part will be repaired or replaced by B&S.

Owner's Warranty Responsibilities

As the small off-road engine owner, you are responsible for the performance of the required maintenance listed in your Operating and Maintenance Instructions. B&S recommends that you retain all your receipts covering maintenance on your small off-road engine, but B&S cannot deny warranty solely for the lack of receipts or for your failure to ensure the performance of all scheduled maintenance.

As the small off-road engine owner, you should however be aware that B&S may deny you warranty coverage if your small off-road engine or a part has failed due to abuse, neglect, improper maintenance or unapproved modifications.

You are responsible for presenting your small off-road engine to an Authorized B&S Service Dealer as soon as a problem exists. The undisputed warranty repairs should be completed in a reasonable amount of time, not to exceed 30 days.

If you have any questions regarding your warranty rights and responsibilities, you should contact a B&S Service Representative at 1-414-259-5262.

The emissions warranty is a defects warranty. Defects are judged on normal engine performance. The warranty is not related to an in-use emissions test.

Briggs & Stratton Emissions Control Defects Warranty Provisions

The following are specific provisions relative to your Emissions Control Defects Warranty Coverage. It is in addition to the B&S engine warranty for non-regulated engines found in the Operating and Maintenance Instructions.

1. Warranted Parts

Coverage under this warranty extends only to the parts listed below (the emissions control systems parts) to the extent these parts were present on the engine purchased.

- a. Fuel Metering System
 - Cold start enrichment system (soft choke)
 - Carburetor and internal parts
 - Fuel pump
 - Fuel line, fuel line fittings, clamps
 - Fuel tank, cap and tether
 - Carbon canister
- b. Air Induction System
 - Air cleaner
 - Intake manifold
 - Purge and vent line
- c. Ignition System
 - Spark plug(s)
 - Magneto ignition system
- d. Catalyst System
 - Catalytic converter
 - Exhaust manifold
 - Air injection system or pulse valve
- e. Miscellaneous Items Used in Above Systems
 - Vacuum, temperature, position, time sensitive valves and switches
 - Connectors and assemblies

2. Length of Coverage

B&S warrants to the initial owner and each subsequent purchaser that the Warranted Parts shall be free from defects in materials and workmanship which caused the failure of the Warranted Parts for a period of two years from the date the engine is delivered to a retail purchaser.

3. No Charge

Repair or replacement of any Warranted Part will be performed at no charge to the owner, including diagnostic labor which leads to the determination that a Warranted Part is defective, if the diagnostic work is performed at an Authorized B&S Service Dealer. For emissions warranty service contact your nearest Authorized B&S Service Dealer as listed in the "Yellow Pages" under "Engines, Gasoline," "Gasoline Engines," "Lawn Mowers," or similar category.

4. Claims and Coverage Exclusions

Warranty claims shall be filed in accordance with the provisions of the B&S Engine Warranty Policy. Warranty coverage shall be excluded for failures of Warranted Parts which are not original B&S parts or because of abuse, neglect or improper maintenance as set forth in the B&S Engine Warranty Policy. B&S is not liable to cover failures of Warranted Parts caused by the use of add-on, non-original, or modified parts.

5. Maintenance

Any Warranted Part which is not scheduled for replacement as required maintenance or which is scheduled only for regular inspection to the effect of "repair or replace as necessary" shall be warranted as to defects for the warranty period. Any Warranted Part which is scheduled for replacement as required maintenance shall be warranted as to defects only for the period of time up to the first scheduled replacement for that part. Any replacement part that is equivalent in performance and durability may be used in the performance of any maintenance or repairs. The owner is responsible for the performance of all required maintenance, as defined in the B&S Operating and Maintenance Instructions.

6. Consequential Coverage

Coverage hereunder shall extend to the failure of any engine components caused by the failure of any Warranted Part still under warranty.

Look For Relevant Emissions Durability Period and Air Index Information On Your Engine Emissions Label

Engines that are certified to meet the California Air Resources Board (CARB) Tier 2 Emissions Standards must display information regarding the Emissions Durability Period and the Air Index. Briggs & Stratton makes this information available to the consumer on our emissions labels. The engine emission label will indicate certification information.

The **Emissions Durability Period** describes the number of hours of actual running time for which the engine is certified to be emissions compliant, assuming proper maintenance in accordance with the Operating & Maintenance Instructions. The following categories are used:

Moderate:

Engine is certified to be emissions compliant for 125 hours of actual engine running time.

Intermediate:

Engine is certified to be emissions compliant for 250 hours of actual engine running time.

Extended:

Engine is certified to be emissions compliant for 500 hours of actual engine running time. For example, a typical walk-behind lawn mower is used 20 to 25 hours per year. Therefore, the **Emissions Durability Period** of an engine with an **intermediate** rating would equate to 10 to 12 years.

Certain Briggs & Stratton engines will be certified to meet the United States Environmental Protection Agency (USEPA) Phase 2 emission standards. For Phase 2 certified engines, the Emissions Compliance Period referred to on the Emissions Compliance label indicates the number of operating hours for which the engine has been shown to meet Federal emission requirements.

For engines less than 225 cc displacement.

Category C = 125 hours

Category B = 250 hours

Category A = 500 hours

For engines of 225 cc or more displacement.

Category C = 250 hours

Category B = 500 hours

Category A = 1000 hours.

TECHNICAL INFORMATION

Engine Power Rating Information

The gross power rating for individual gas engine models is labeled in accordance with SAE (Society of Automotive Engineers) code J1940 (Small Engine Power & Torque Rating Procedure), and rating performance has been obtained and corrected in accordance with SAE J1995 (Revision 2002-05). Torque values are derived at 3060 RPM; horsepower values are derived at 3600 RPM. Actual gross engine power will be lower and is affected by, among other things, ambient operating conditions and engine-to-engine variability. Given both the wide array of products on which engines are placed and the variety of environmental issues applicable to operating the equipment, the gas engine will not develop the rated gross power when used in a given piece of power equipment (actual "on-site" or net power). This difference is due to a variety of factors including, but not limited to, accessories (air cleaner, exhaust, charging, cooling, carburetor, fuel pump, etc.), application limitations, ambient operating conditions (temperature, humidity, altitude), and engine-to-engine variability. Due to manufacturing and capacity limitations, Briggs & Stratton may substitute an engine of higher rated power for this Series engine.

BRIGGS & STRATTON ENGINE OWNER WARRANTY POLICY

Effective 12/06

LIMITED WARRANTY

Briggs & Stratton Corporation will repair or replace, free of charge, any part(s) of the engine that is defective in material or workmanship or both. Transportation charges on parts submitted for repair or replacement under this warranty must be borne by purchaser. This warranty is effective for and is subject to the time periods and conditions stated below. For warranty service, find the nearest Authorized Service Dealer in our dealer locator map at www.briggsandstratton.com, or by calling 1-800-233-3723, or as listed in the "Yellow Pages"™.

THERE IS NO OTHER EXPRESS WARRANTY. IMPLIED WARRANTIES, INCLUDING THOSE OF MERCHANTABILITY AND FITNESS FOR A PARTICULAR PURPOSE, ARE LIMITED TO ONE YEAR FROM PURCHASE, OR TO THE EXTENT PERMITTED BY LAW ANY AND ALL IMPLIED WARRANTIES ARE EXCLUDED. LIABILITY FOR INCIDENTAL OR CONSEQUENTIAL DAMAGES ARE EXCLUDED TO THE EXTENT EXCLUSION IS PERMITTED BY LAW. Some states or countries do not allow limitations on how long an implied warranty lasts, and some states or countries do not allow the exclusion or limitation of incidental or consequential damages, so the above limitation and exclusion may not apply to you. This warranty gives you specific legal rights and you may also have other rights which vary from state to state and country to country.

WARRANTY TERMS **

Brand/Product Type	Consumer Use	Commercial Use
Vanguard™	2 years	2 years
Extended Life Series™, I/C®®, Intek I/C®®, Intek Pro™	2 years	1 year
Kerosene Fuel Operated Engines	1 year	90 days
All Other Briggs & Stratton Engines	2 years	90 days

** Engines used on Home Standby Generator applications are warranted under consumer use only. This warranty does not apply to engines on equipment used for prime power in place of a utility. Engines used in competitive racing or on commercial or rental tracks are not warranted.

The warranty period begins on the date of purchase by the first retail consumer or commercial end user, and continues for the period of time stated in the table above. "Consumer use" means personal residential household use by a retail consumer. "Commercial use" means all other uses, including use for commercial, income producing or rental purposes. Once an engine has experienced commercial use, it shall thereafter be considered as a commercial use engine for purposes of this warranty.

NO WARRANTY REGISTRATION IS NECESSARY TO OBTAIN WARRANTY ON BRIGGS & STRATTON PRODUCTS. SAVE YOUR PROOF OF PURCHASE RECEIPT. IF YOU DO NOT PROVIDE PROOF OF THE INITIAL PURCHASE DATE AT THE TIME WARRANTY SERVICE IS REQUESTED, THE MANUFACTURING DATE OF THE PRODUCT WILL BE USED TO DETERMINE THE WARRANTY PERIOD.

ABOUT YOUR ENGINE WARRANTY

Briggs & Stratton welcomes warranty repair and apologizes to you for being inconvenienced. Any Authorized Service Dealer may perform warranty repairs. Most warranty repairs are handled routinely, but sometimes requests for warranty service may not be appropriate. For example, warranty would not apply if engine damage occurred because of misuse, lack of routine maintenance, shipping, handling, warehousing or improper installation. Similarly, warranty is void if the serial number of the engine has been removed or the engine has been altered or modified.

If a customer differs with the decision of the Service Dealer, an investigation will be made to determine whether the warranty applies. Ask the Service Dealer to submit all supporting facts to his Distributor or the Factory for review. If the Distributor or the Factory decides that the claim is justified, the customer will be fully reimbursed for those items that are defective. To avoid misunderstanding which might occur between the customer and the Dealer, listed below are some of the causes of engine failure that the warranty does not cover.

Normal wear:

Engines, like all mechanical devices, need periodic parts service and replacement to perform well. Warranty will not cover repair when normal use has exhausted the life of a part or an engine.

Improper maintenance:

The life of an engine depends upon the conditions under which it operates, and the care it receives. Some applications, such as tillers, pumps and rotary mowers, are very often used in dusty or

dirty conditions, which can cause what appears to be premature wear. Such wear, when caused by dirt, dust, spark plug cleaning grit, or other abrasive material that has entered the engine because of improper maintenance, is not covered by warranty.

This warranty covers engine related defective material and/or workmanship only, and not replacement or refund of the equipment to which the engine may be mounted. Nor does the warranty extend to repairs required because of:

1. PROBLEMS CAUSED BY PARTS THAT ARE NOT ORIGINAL BRIGGS & STRATTON PARTS.
2. Equipment controls or installations that prevent starting, cause unsatisfactory engine performance, or shorten engine life. (Contact equipment manufacturer.)
3. Leaking carburetors, clogged fuel pipes, sticking valves, or other damage, caused by using contaminated or stale fuel. (Use clean, fresh, lead-free gasoline and Briggs & Stratton Fuel Stabilizer, Part No. 5041.)
4. Parts which are scored or broken because an engine was operated with insufficient or contaminated lubricating oil, or an incorrect grade of lubricating oil. OIL GARD may not shut down running engine. Engine damage may occur if oil level is not properly maintained.
5. Repair or adjustment of associated parts or assemblies such as clutches, transmissions, remote controls, etc., which are not manufactured by Briggs & Stratton.
6. Damage or wear to parts caused by dirt, which entered the engine because of improper air cleaner maintenance,

re-assembly, or use of a non-original air cleaner element or cartridge.

7. Parts damaged by over-speeding, or overheating caused by grass, debris, or dirt, which plugs or clogs the cooling fins, or flywheel area, or damage caused by operating the engine in a confined area without sufficient ventilation.
8. Engine or equipment parts broken by excessive vibration caused by a loose engine mounting, loose cutter blades, unbalanced blades or loose or unbalanced impellers, improper attachment of equipment to engine crankshaft, over-speeding or other abuse in operation.
9. A bent or broken crankshaft, caused by striking a solid object with the cutter blade of a rotary lawn mower, or excessive v-belt tightness.
10. Routine tune-up or adjustment of the engine.
11. Engine or engine component failure, i.e., combustion chamber, valves, valve seats, valve guides, or burned starter motor windings, caused by the use of alternate fuels such as, liquified petroleum, natural gas, altered gasolines, etc.

Warranty is available only through service dealers which have been authorized by Briggs & Stratton Corporation. your nearest Authorized Service Dealer is listed in the "Yellow Pages"™ of your telephone directory under "Engines, Gasoline" or "Gasoline Engines," "Lawn Mowers," or similar category.

Briggs & Stratton Engines Are Made Under One Or More Of The Following Patents: Design D-247,177 (Other Patents Pending)										
6,691,683	6,520,141	6,325,036	6,145,487	6,012,420	5,803,035	5,548,955	5,243,878	5,138,996	4,875,448	D 476,629
6,647,942	6,495,267	6,311,663	6,142,257	5,992,367	5,765,713	5,546,901	5,235,943	5,086,890	4,819,593	D 457,891
6,622,683	6,494,175	6,284,123	6,135,426	5,904,124	5,732,555	5,445,014	5,234,038	5,070,829	4,720,638	D 368,187
6,615,787	6,472,790	6,263,852	6,116,212	5,894,715	5,645,025	5,503,125	5,228,487	5,058,544	4,719,682	D 375,963
6,617,725	6,460,502	6,260,529	6,105,548	5,887,678	5,642,701	5,501,203	5,197,426	5,040,644	4,633,556	D 309,457
6,603,227	6,456,515	6,242,828	6,347,614	5,852,951	5,628,352	5,497,679	5,197,425	5,009,208	4,630,498	D 372,871
6,595,897	6,382,166	6,239,709	6,082,323	5,843,345	5,619,845	5,320,795	5,197,422	4,996,956	4,522,080	D 361,771
6,595,176	6,369,532	6,237,555	6,077,063	5,823,153	5,606,948	5,301,643	5,191,864	4,977,879	4,520,288	D 356,951
6,584,964	6,356,003	6,230,678	6,064,027	5,819,513	5,606,851	5,271,363	5,188,069	4,977,877	4,512,499	D 309,457
6,557,833	6,349,688	6,213,083	6,040,767	5,813,384	5,605,130	5,269,713	5,186,142	4,971,219	4,453,507	D 308,872
6,542,074	6,347,614	6,202,616	6,014,808	5,809,958	5,497,679	5,265,700	5,150,674	4,895,119	4,430,984	D 308,871

Fig. 5

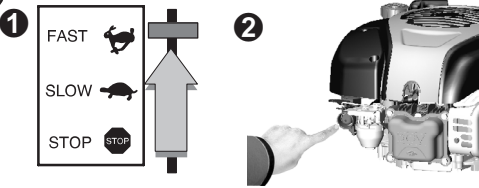

Fig. 6

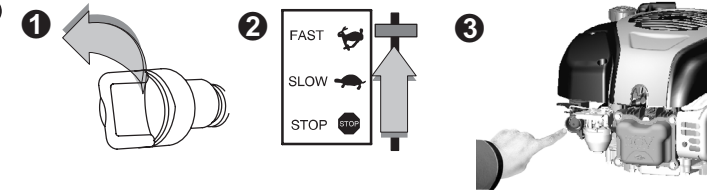

Fig. 7

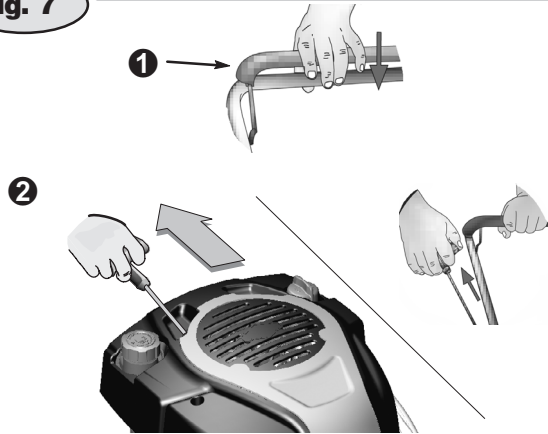

Fig. 8

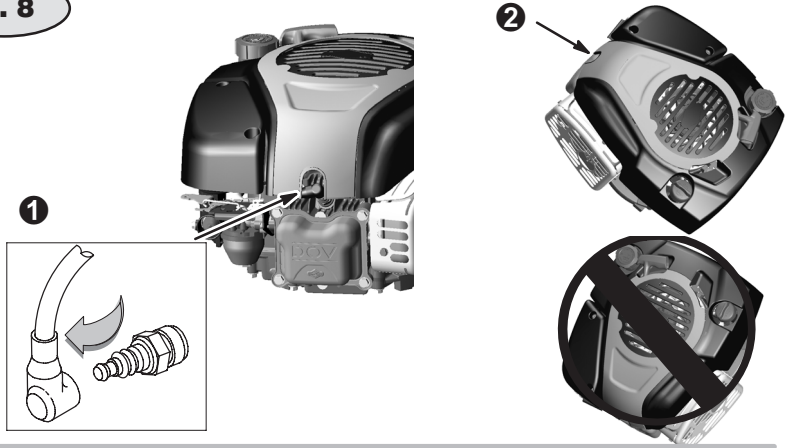

Fig. 9

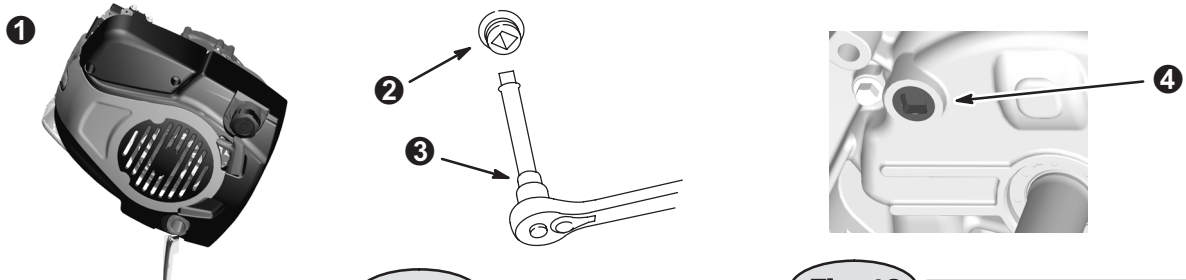

Fig. 10

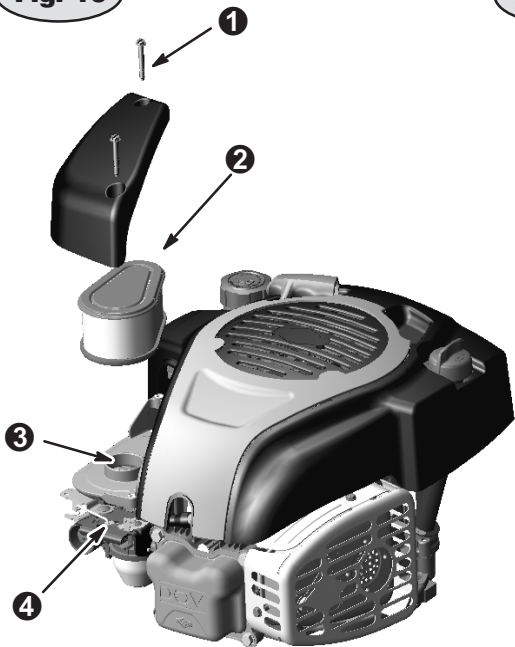

Fig. 11

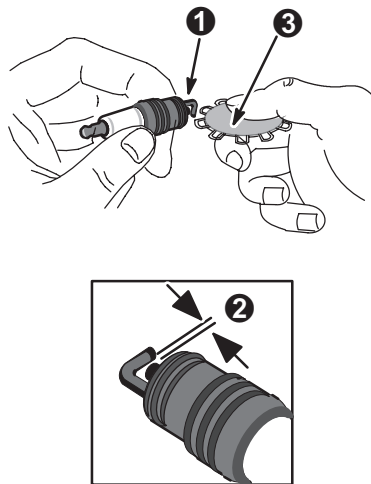
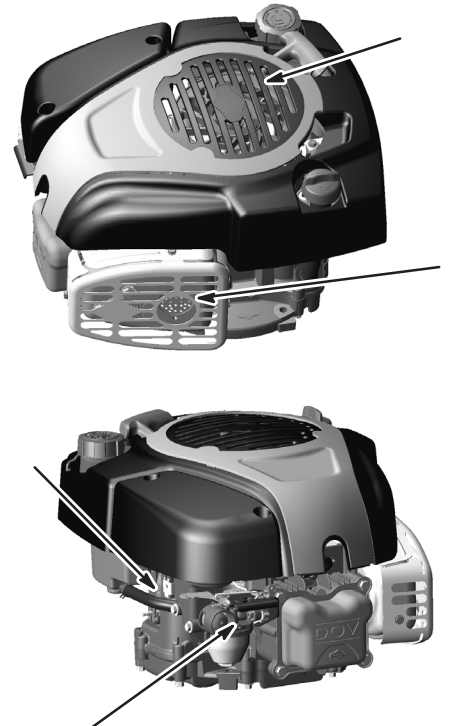

Fig. 12





THE POWER WITHIN™