

MANUAL

CARAVAN

RA/RM-2D

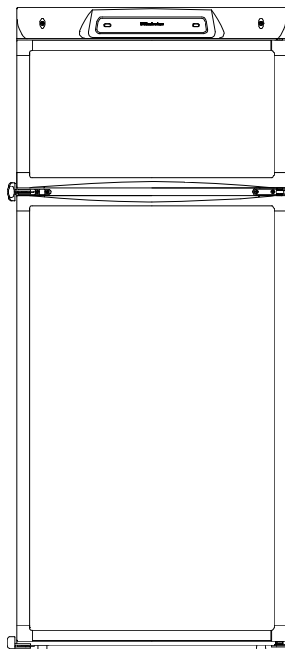

AES II

RM 6505

Deutsch Seite 3

English page 12

Italiano pagina 20

Nederlands pag. 29

Français page 38



OPERATING AND INSTALLATION INSTRUCTIONS FOR ELECTROLUX REFRIGERATORS

INTRODUCTION

We are pleased that you have chosen this refrigerator and hope you will derive much satisfaction from using it, but first a few well-meant words of advice:

It is important to read through these instructions carefully before using the refrigerator.

To ensure good refrigeration and economical operation, the refrigerator must be installed and used as described in these instructions.

The refrigerator is designed for installation in motor-homes.

This refrigerator comes with an

Automatic Energy Selector (AES)

which controls operation and energy supply. To put the refrigerator in operation, just trip the main switch - AES manages the rest.

TRANSIT DAMAGE

Inspect the refrigerator for damage. Transit damage must be reported to whoever is responsible for delivery not later than seven days after the refrigerator was delivered.

DATA PLATE

Check the data plate, inside the refrigerator, to ensure that you have received the right model.

The data plate contains e. g. the following details:

Model designation	RM.....
Product number
Serial number
Voltage volts
Gas pressure mbar

Since these details will be needed if you have to contact service personnel, it is a good idea to make a note of them here.

CONTENTS

OPERATING INSTRUCTIONS	13
CONTROLS	13
STARTING THE REFRIGERATOR	13
SWITCHING BETWEEN ENERGY	
SOURCES	13
REGULATING THE TEMPERATURE	13
TRAVEL CATCH	14
FOOD STORAGE	14
ICE-MAKING	14
DEFROSTING	14
CLEANING THE REFRIGERATOR	14
HEATING CABLE	14
WINTER OPERATION	14
TURNING OFF THE REFRIGERATOR	14
IF THE REFRIGERATOR FAILS	
TO WORK	15
MAINTENANCE	15
SERVICE	15
INSTALLATION INSTRUCTION	15
REPOSITIONING THE HINGES	15
DOOR PANEL	15
INSTALLATION/BUILDING-IN	16
VENTILATION OF THE UNIT	16
LP GAS CONNECTION	17
ELECTRICAL CONNECTION	18
TECHNICAL DATA	19

OPERATING INSTRUCTIONS

CONTROLS

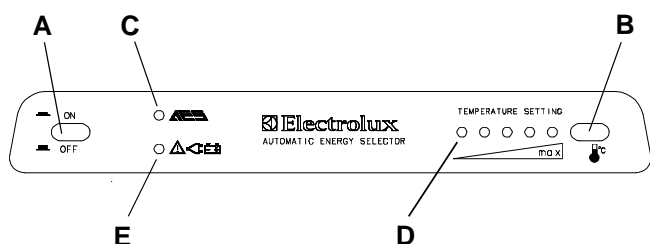

FIG. 1

This refrigerator is equipped with an Automatic Energy Selector (**AES**) which controls its operation and energy supply.

The system selects the available energy source in the order:

230-240 V - 12 V - LP gas

No manual operation is necessary for selecting the energy source.

The control panel is shown in fig.1.

The refrigerator is set into operation by pushing button (A) (main switch). The AES LED (C) lights green showing: AES system working. Push- button (B) is used for setting the electronic thermostat. The thermostat LEDs (D) shows the chosen temperature position. When there is a demand for refrigeration, AES will connect the most favourable of the available energy sources.

Note: 12 V must always be available to supply the electronics.

STARTING THE REFRIGERATOR

All references are to fig. 1.

LP Gas operation

AES will select LP gas operation under the following conditions:

- No AC (230-240 V) available
- Engine not running (no high current at 12 V DC available)
- AC available **but too low**
- Engine running **but DC supply too low** (condition three and four are briefly described in item **Undervoltage operation**)

When the system chooses LP Gas operation, the flame failure device is automatically opened, allowing the gas to flow to the burner. At the same time, the electronic igniter is energized.

After initial installation, servicing, or changing gas cylinders etc., the gas pipes may contain some air that should

be allowed to escape by briefly turning on the refrigerator or other appliances. This will ensure that the flame lights immediately.

If the flame goes out (by gust of wind etc.), the igniter is immediately activated and reignites the gas.

Note: The control electronics and the igniter must have 12 V DC supply to operate.

Gas trouble-shooting

If the AES LED (C) is flashing red, the system was not able to start or continue gas operation. Set the switch (A) to "OFF" and check that there is enough gas in the gas bottle, that its valve is open and that any valves in the gas line to the refrigerator are open.

Then push button (A) to "ON" again. After 10 sec. AES will repeat the ignition sequence. When the AES LED (C) again starts flashing red after 30 sec., the trouble persists (air in the line, no gas?). Switch (A) briefly off and then on again. It might be necessary to repeat this operation 2-3 times if the tubing contains air (after changing gas bottles, repairs etc.).

If this does not help, you should consult a service technician.

230-240 V Operation

When a mains connection is available, AES will select this. Please note, that even being in AC mode, 12 V DC is necessary for the internal supply of the electronics.

12 V Operation

AES will select the 12 V mode of operation only when the vehicle engine is running (detected by the alternator connection of the fridge D+).

SWITCHING BETWEEN ENERGY SOURCES

When switching from one energy source to another, there are some delays implemented in the AES system. The 15 min. delay between switching off the engine and starting gas mode is intended to delay the starting of gas mode e.g. when stopping at a filling station.

WARNING: It is not allowed to have a naked flame at a gas filling station. If you are not sure, that your stop is shorter than 15 min., you are advised to switch off the main switch (A), fig. 1, when stopping at a filling station.

Undervoltage operation

The AES system is designed to guarantee the maximum cooling efficiency under any circumstances. Therefore, the system monitors continuously the voltage level while being in either 12 V DC or 230-240 V AC mode. If the voltage is too low, the system switches to Gas mode shown by the yellow LED (E in fig. 1.). The system stays in Gas mode, until the electrical supply voltage has recovered to normal level.

REGULATING THE TEMPERATURE

The position number refers to fig.1.

It will take a few hours for the refrigerator to reach normal operating temperature. So we suggest you start it well in advance of a trip and if possible store it with precooled

foodstuffs.

The temperature of the refrigerator main compartment is set for all three sources of energy, by means of the thermostat knob (B). After turning on the refrigerator the system automatically chooses the mid- position. With some experience you will soon find a suitable setting. This normally does not need resetting because the same thermostat controls the main compartment temperature for any of the three sources of energy.

TRAVEL CATCH

The refrigerator is equipped with two travel catches. Make sure that both are engaged when the motorhome is on the move.

FOOD STORAGE

Always keep food in closed containers. Never put hot food in the refrigerator; allow it to cool first.

Never keep items in the refrigerator that might give off flammable gases.

The frozen food compartment is intended for the storage of frozen food and for making ice. It is not suitable for freezing items of food.

Never put bottles or cans of fizzy drinks in the frozen food storage compartment as they may burst when freezing.

Most kinds of frozen food can be stored in the frozen food compartment for about a month. This period of time may vary, however, and it is important to follow the instructions on the individual packages.

ICE MAKING

Fill the ice tray to just below the brim with drinking water and place it on the freezer shelf.

Ice will be made more rapidly if the thermostat is set at its highest position, but be sure to move the thermostat back to normal setting when the ice is formed, the refrigerator might otherwise become too cold.

DEFROSTING

Frost will gradually accumulate on the refrigerating surfaces. It must not be allowed to grow too thick as it acts as an insulator and adversely affects refrigerator performance. Check the formation of frost regularly every week and when it gets about 3 mm thick, defrost the refrigerator.

To defrost the refrigerator, turn it off and remove the ice trays and the food item, leave the cabinet and freezer doors open.

Do not try to accelerate defrosting by using any kind of heating appliance, as this might damage the plastic surfaces of the refrigerator. Neither should any sharp objects be used to scrape off the ice.

Defrost water runs from a collector channel to a receptacle at the rear of the refrigerator where it normally evaporates.

Heavy frosts build up on the freezer plate and the cooling fins, and a lot of defrost water, move the plastic drain tube in to a watertight bucket or container. (Access through the lower ventilation grill on the outside of the motorhome). As the frost melts, the water will flow into the container. Replace the drain tube to its original position after defrosting.

Defrost water in the freezer compartment should be mopped up with a cloth.

When the ice has melted, wipe the refrigerator dry and restart it. Place the food items back inside but wait until the refrigerator is cold before making ice cubes.

CLEANING THE REFRIGERATOR

Clean the inside of the refrigerator regularly to keep it fresh and hygienic.

Soak a cloth in a solution consisting of a teaspoon of bicarbonate of soda to half a litre of warm water. Wring out the cloth and use it to clean the interior of the refrigerator and its fittings.

Never use detergents, scouring powder, strongly scented products or wax polish to clean the interior of the refrigerator as they may damage the surfaces and leave a strong odour.

The exterior of the refrigerator should be wiped clean now and then, using a damp cloth and a small quantity of detergent. But not the door gasket, which should only be cleaned with soap and water and then thoroughly dried.

The cooling unit behind the refrigerator should be cleaned with a brush from time to time, but make sure that the refrigerator is switched off when doing this.

HEATING CABLE

During the summer months of high temperatures and humidity, the metal frame between the freezer and fresh food compartments may have water droplets forming.

This refrigerator comes standard with a 12 V (DC) heating cable that will evaporate the water droplets when they form.

To have the heating cable on, you position the switch located beneath the control panel to I. The heating cable can be left on continuously or only used when temperatures require it.

Note: The heating cable will draw 12 V (DC) power continuously when in the ON (I) position. It should be turned OFF (0) when a charging source is not available.

WINTER OPERATION

Please check that the ventilation grilles are not blocked by snow, leaves etc.

ELECTROLUX ventilation grilles model L500, can be fitted with winter covers, model WA130, to protect the cooling unit against cold air. The covers may be fitted when the outside temperature is below approx. 10°C and should be fitted when the temperature is below the freezing point.

We suggest that you fit the winter covers also in the case that the vehicle is laid up during the winter months.

TURNING OFF THE REFRIGERATOR

If the refrigerator is not to be used for some time:

1. Set the switch (A), fig. 1, to "OFF".
2. Shut off any on-board valve in the gas line to the refrigerator.
3. Empty the refrigerator. Defrost and clean it as described earlier. Leave the doors of the refrigerator and frozen food compartment ajar.
4. When the motorhome is laid up for a long period of time (e.g. during the winter months), we suggest fitting the winter covers WA130 onto the vent grills.

IF THE REFRIGERATOR FAILS TO WORK

Check the following points before calling a service technician:

1. that the green AES LED goes on, when the switch (A) is set to "ON" (12 V must be available).
2. when mains are connected but the refrigerator stays in gas operation: Is the refrigerator correctly connected and is the fuse (230-240 V) intact?.
3. is the 12 V fuse intact?
4. **Disconnect the wall plug, and the 12 V wires before servicing.** Check the fuses on the circuit board, (under the black cover at the top of the refrigerator and behind the control panel). Remove the two screws holding the control panel, pull out the control panel with its electronics. Remove the cover and check the fuses.
5. if the refrigerator does not operate in DC mode when the engine is running:
Is the alternator (D+) connection made correctly?
6. if the AES LED (C) flashes red: see chapter **Gas trouble-shooting**.

If the refrigerator is not cold enough it may be because:

1. The ventilation is inadequate owing to reduced area of the ventilation passages (partial blockage of grilles from wire mesh etc.).
2. The evaporator is frosted up.
3. The temperature control setting is incorrect.
4. The gas pressure is incorrect - check the pressure regulator at the gas container.
5. The ambient temperature is too high.
6. Too much food is loaded at one time.
7. The door is not properly closed or the magnetic sealing strip is defective.

If the refrigerator still does not work properly, call a service technician.

WARNING! The sealed cooling system must not be opened, since it contains corroding chemicals under high pressure.

MAINTENANCE

Always turn to a qualified service technician who is familiar with LP gas systems and refrigerator.

We recommend that a service technician check the refrigerator once a year.

- Check that the gas safety shut-off valve is working properly.
- The ventilation openings are unobstructed.
- The Instruction Manual is available.
- Check all connections in the LP gas system for gas leaks. Connections can be tested for leaks using a soap solution. **Do not use a naked flame!** If there is any suspicion of damage, call for a service technician.
- Check that the burner is clean and free from combustible material.

SOME USEFUL HINTS

Make sure that:

- Defrosting is carried out periodically
- The refrigerator is clean and dry with the door left open when it is not to be used for some time.
- Liquids or items with a strong odour are well packed.
- The ventilation openings are unobstructed.
- The doors are secured by means of the both travel catches when the caravan is on the move.

SERVICE AND SPARE PARTS

Service and spare parts are obtainable from your dealer or Electrolux - consult the telephone directory.

INSTALLATION INSTRUCTIONS

REPOSITIONING THE HINGES

The refrigerator is equipped with reversible doors.

A special door reversing kit must be used to reverse the doors.

For further information, contact your dealer or Electrolux.

DOOR PANEL

Door panels can easily be fitted or changed. The dimensions of the panels must be:

Model		RM 6505
Height	upper door	265 ±1mm
	lower door	833 ±1mm
Width		483 ±1mm
Thickness max.		4 mm

Before starting the mounting work, check that the panel dimensions are in compliance with those given in the table and the instructions are read thoroughly.

When mounting the panel, proceed as follows:

Upper door

- remove the two screws holding the control panel
- unscrew the upper hinge pin and remove the door
- unscrew the upper part of the door frame, remove the old panel
- insert the new panel and push the panel downwards
- fasten the upper part of the door frame with its three screws
- please note that the panel must be changed on the lower door, before the upper door can be mounted

Lower door

- unscrew the middle hinge pin and remove the door
- unscrew the lower part of the door frame, remove the panel stop (2x) and remove the old panel
- insert the new panel and push the panel upwards, put the panel stop back in place and fasten the lower part of the door frame with its three screws
- replace the lower door

- replace the upper door
- replace the control panel with its two screws.

INSTALLATION/BUILDING-IN

The refrigerator is intended for installation in a motor-home, and the description relates to this application.

The refrigerator must not be exposed to radiated heat from hot objects.

Excessive heat irradiation impairs performance and leads to increased energy consumption. For this reason the refrigerator should be installed if possible not at the entrance side of the vehicle - normally orientated south and often with an awning which would impair the dispersion of heat and combustion gases from the ventilation openings.

It is not a good practice to install the refrigerator so that the vent openings are covered by the vehicle's entrance door when this is set open. This would reduce the ventilation airflow to the cooling unit and reduce refrigeration performance.

The enclosure

The refrigerator must be installed in a substantial enclosure and must be level, the dimensions are shown in **TECHNICAL DATA**.

The bottom of the enclosure must be horizontal and even so that the refrigerator can be easily pushed into place. It must be sturdy enough to carry the weight of the refrigerator.

Battens must be installed at the bottom, sides and top of the enclosure and fitted with sealing strips.

Slide in the refrigerator until it is flush with the front of the recess. There must be 10-20 mm free space behind the refrigerator

Six fasteners are fitted in plastic bushings in the side walls of the refrigerator, fig. 2. They are used for securing the refrigerator in the enclosure.

The side walls of the enclosure and/or any wooden braces installed to hold the refrigerator must be dimensioned to seat the screws securely, also considering the forces due to the movement of the vehicle.

With the refrigerator in place, drive the screws through the lining of the refrigerator into the walls of the enclosure. There must not be more than 3 mm of clearance between refrigerator and enclosure on each side. If necessary, wooden strips or similar should be fitted.

Note: This is the only approved means of securing the refrigerator to the enclosure and to the vehicle. Fasteners penetrating other parts of the insulation (PU) foam of the refrigerator might damage components like electric wiring etc.

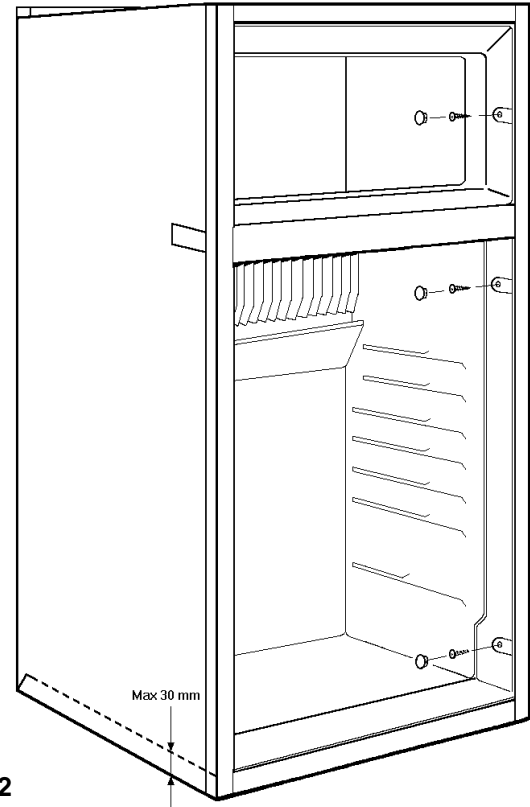

FIG. 2

VENTILATION OF THE UNIT

At high ambient temperatures the refrigeration unit will only perform adequately when properly ventilated.

Side ventilation.

The refrigerator unit is ventilated via two openings in the wall of the motorhome (fig. 3a).

Fresh air enters through the lower opening and warm air is discharged through the upper one.

The lower opening should be located at floor level (to allow any leaking gas to escape to the outside).

The upper ventilation opening should be located above the condenser, as high as possible, to ensure good ventilation.

Roof ventilation

The ventilation of the cooling unit can also be done via one opening in the wall of the motorhome and one on the roof for the roof vent (fig. 3 b).

Fresh air enters through the lower opening and warm air is discharged through the roof vent.

Ventilation grilles

We recommend fitting 2 side vents, **model L500**, alternative one L500 and one roof vent **model R500**, which are specially developed by Electrolux for this purpose.

The L500-ventilation grilles permit inspection and small repairs to be carried out without the necessity to remove the refrigerator from the recess.

VENTILATION OF THE UNIT

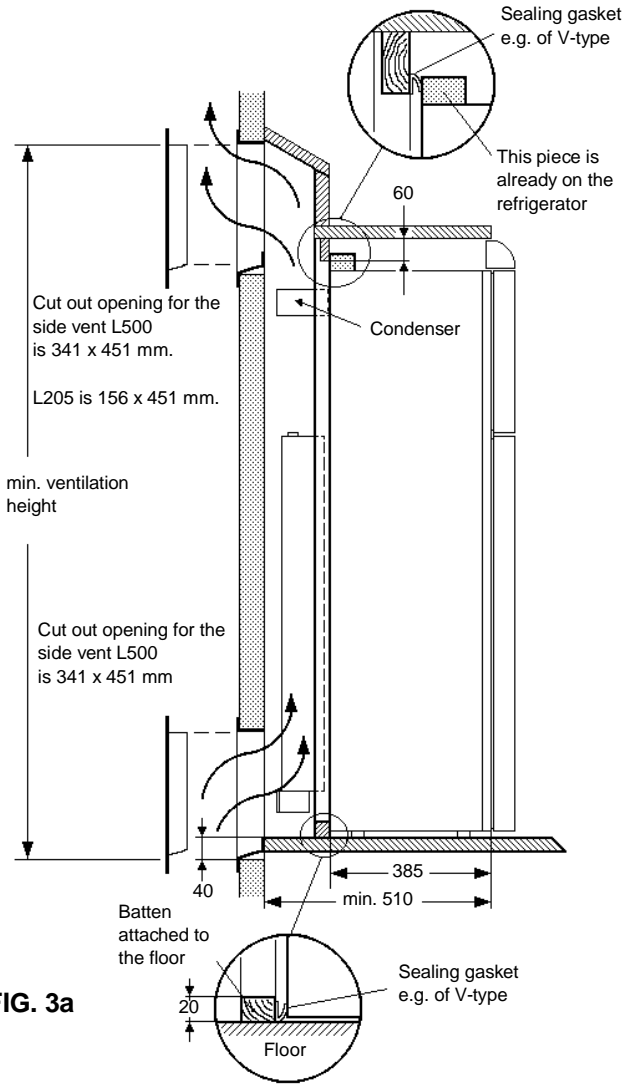

FIG. 3a

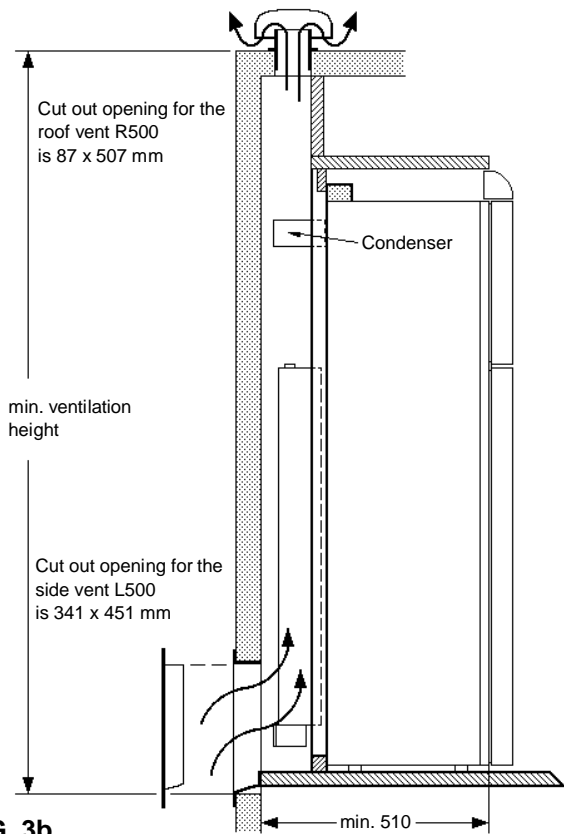

FIG. 3b

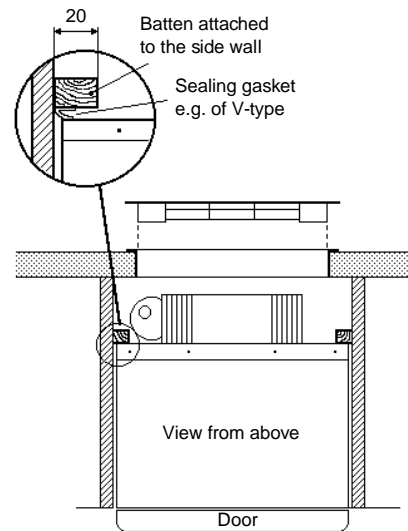

FIG. 3c

Removal of flue gases

The ventilation passage at the rear of the recess, between the outer wall of the motorhome and the refrigerator (fig. 3a/b/c), must be sealed off against the living space, so cold draughts are excluded (winter camping) and **no flue gases can penetrate into the motorhome.**

The flue gases are dispersed through the upper vent grille or the roof vent together with the ventilation air. The top, bottom and sides of the ventilation passage should be insulated to prevent condensation and cold draughts.

Ventilation heights

Minimum ventilation heights in mm.

Model	Installation with		
	Upper side vent L205 Lower side vent L500	Upper side vent L500 Lower side vent L500	Roof vent R500 Lower side vent L500
RM 6505	1400	1400	1250

LP GAS CONNECTION

The refrigerator is designed for operation on LP gas, the pressure of which must be 28 mbar for Butane and 37 mbar for Propane. Check that this is stated on the data plate.

The refrigerator is not designed for operation on town gas or natural gas.

CAUTION! CHECK THAT THE GAS SUPPLIED TO THE REFRIGERATOR IS AT THE CORRECT PRESSURE. SEE THE REDUCING VALVE ON THE LP GAS CONTAINER.

The gas installation should only be carried out by a person experienced in gas fitting. It is recommended that the gas pipe feeding the refrigerator is so arranged that it is possible to turn off the supply of the refrigerator.

It must be of a type approved for use with continuously operating bottled gas appliances, and have threaded compression connections throughout. **PUSH-ON CONNECTIONS MUST NOT BE USED** (We do not recommend the use of "rubber" type flexible tubing for connecting permanently operating appliances of this type in the United Kingdom). All connectors etc. should be of a type specifically designed for the type and diameter of the connection pipe used, and screwed joints should be sealed with a joining compound approved for use with bottled gas.

The gas supply pipe should be connected to the gas inlet pipe (outside diameter 8 mm.) by means of a suitable gas-tight compression fitting, e.g. olive.

In making the connection to the refrigerator, a union gas cock of an approved type bottled gas must be incorporated in the supply line in a position that is readily accessible to the user. For eventual servicing purposes, the union should be on the outlet side of the cock and the pipework should be positioned so as not to prevent the refrigerator from being readily withdrawn.

On completion of installation, the system must be pressure tested by a qualified technician.

ELECTRICAL CONNECTION

The electrical installation must be carried out in a proper and durable manner; taking into accounts all relevant regulations and codes of practice. For mains voltage operation, it is important that the circuit to and in the motorhome is effectively earthed.

For connection to a 230-240 V electricity supply, the refrigerator has a 3-core mains lead which is intended for connection to a properly earthed plug and socket outlet. The socket outlet should be fitted in the motorhome in a position readily accessible to the user, within reach of the mains lead. In the United Kingdom, the plug and socket outlet should be of the non-reversible type.

As the colours of the wires in the mains lead of this appliance may not correspond with the coloured markings identifying the terminals in your plug, proceed as follows:

- the wire which is coloured Green and Yellow must be connected to the terminal in the plug which is marked with the letter E or by the earth symbol \perp , or coloured Green or Green and Yellow,
- the wire which is coloured Blue must be connected to the terminal which is marked with the letter N or coloured Black,

- the wire which is coloured Brown must be connected to the terminal which is marked with the letter L or coloured Red.

WARNING- THIS APPLIANCE MUST BE EARTHED

IMPORTANT

The wires in this mains lead are coloured in accordance with the following code:

- green/yellow: earth
- blue: neutral
- brown: live

In the United Kingdom, the plug or circuit to the refrigerator must be fitted with a fuse not greater than 5 amps. If a 13 amp. (B.S. 1363) fused plug is used, it should be fitted with a 3 amp. fuse, ASTA approved to B.S. 1362. In other countries, the fuse rating will depend upon the voltage and local practice.

230-240 V Supplies.

Check that the voltage stated on the data plate is the same as the main voltage in use (230-240 V).

Plug the 230-240 V refrigerator power cord into an easily accessible wall socket.

Electrical leads must be routed and secured so that they cannot come into contact with hot or sharp parts of the refrigerator.

12 V and "D+" Connection

The 12 V connection of the refrigerator is shown in fig. 4. The (+12 V) and (-) pole have to be connected directly to the "house battery". Do not use the chassis for the return lead.

12 V supply must not be connected to a voltage controller or similar device as the AES itself monitors the DC voltage.

+12 V should be permanent attached, and must not be cut out when the ignition key is turned off.

All connections should be screwed or soldered to keep voltage drop to a minimum. The positive conductor must be protected by a 20 A fuse.

The connection D+ (alternator) has to be connected to the corresponding outlet of the vehicles electrical system.

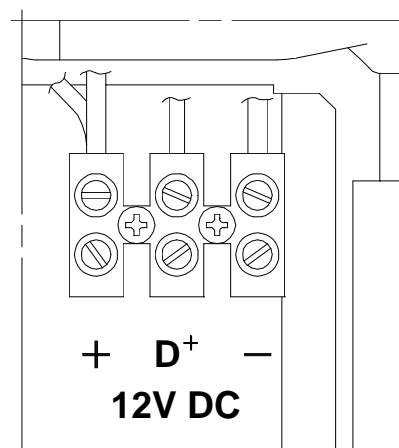

FIG. 4

Cross-sections

The D+ (alternator) is a signal cable and therefore 1-1.5 mm² is sufficient.

Connection to 12 V + and - must be done with a 10 mm² wire if the total wire length (+ and - wire together) is maximally 12 m.

If longer wires are required a bigger cross-section cable is needed.

Please consult a specialist, if you are not familiar with the 12 V electrical system in your motor home.

Interior light - bulb - change

If the bulb has to be replaced, proceed as follows:

1. Remove the cover from the lamp body by pushing it backwards.
2. Remove the bulb.
3. Put in a new bulb (12 V, max. 5 W).
Spare part number for bulb: 200 72 90-03.
4. Push the lamp cover back in place.

TECHNICAL DATA

RM 6505

Overall dimensions, refrigerator	
Height (incl. controls)	1245 mm
Width	525 mm
Depth (incl. cooling unit)	
with door	545 mm
without door	495 mm
Recess dimensions	
Height	1248 mm
Width	530 mm
Depth	510 mm
Capacity	
Gross	135 litres
Net	124.5 litres
Frozen food compartment	23.5 litres
Weight (without packaging)	44 kg
Electrical data	
Input 230-240 volt	220 watt
12 volt	175 watt
* Energy consumption (in 24h) ...	3 kWh
LP gas data	
Input, max.	0.34 kW
* Energy consumption (in 24h) ...	300 g
Cooling medium: Ammonia	

* Average consumption in 24 h at 25°C mean annual ambient temperature according to ISO standards.
Subject to alteration without notice.

Wiring diagram RM 6505

