

# BURCO

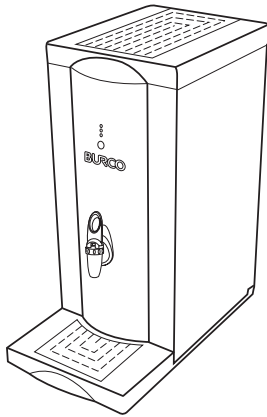

Please read and keep these instructions

## Autofill counter top water boiler

For Burco wall mounted boilers 76500, 76501 & 76502

### Getting the best from your water boiler



- Remove any plastic film from the water boiler before use
- Any water in the water boiler is due to testing and is normal
- The water boiler must be used on a flat level surface
- Boil and discard the water twice before general use



### Helplines

UK 0870 060 2618

Spare & Warranty 0870 167 6648

[www.burco.co.uk](http://www.burco.co.uk)



## Important safety instructions

The use of any electrical appliance requires following common sense safety rules. Primarily there is danger of personal injury and secondly danger of damage to the appliance and property. These are indicated in the instructions text by the following two conventions:

**WARNING: Danger of personal injury.**  
IMPORTANT: Damage to the appliance.

In addition we offer the following essential safety advice.

## General information

Scale build up can damage any appliance which boiling water passes through. Burco autofill water boilers have an easy descale system to make descaling your boiler and preventing it from scale damage as easy as possible. Failure to descale your Burco autofill water boiler will invalidate your guarantee.

Before general use it is recommended that the unit is boiled and emptied through the tap twice discarding the water each time. For best taste and to protect your water boiler from limescale Burco suggest you filter the water supply.

## Location

- Do not use your autofill water boiler outside.
- All sides must be at least 100mm from any walls.
- On a flat level surface.

## Ambient Temperature

This appliance is designed to operate in an ambient temperature between 10°C and 40°C.

## Mains lead

- The mains lead should reach from the wall socket the autofill water boiler without straining the connections.
- Do not let the cord hang over the edge of the table or the counter and keep it away from any hot surfaces.
- Do not let the lead run across an open space e.g. between a low socket and table.
- Do not place the autofill water boiler where the mains lead could fall into a sink.

## Your safety

**WARNING: Extreme caution must be used when moving the autofill water boiler as it is very heavy.**

- Do not continue to use the water boiler if the warning lights are flashing, consult advance diagnostics service light warning codes.
- Do not use boiler if it has been damaged in any way.
- Do not place the appliance on or near hot surfaces.
- Do not use accessories or attachments which Burco have not recommended as they can cause hazards.
- Always switch off, empty and disconnect the autofill water boiler before moving the unit.

**WARNING: The only parts you should touch behind the front panel are the two red isolation valves and the reset button.**

**WARNING: To avoid being scalded when the water boiler is in operation or has just been switched off keep hands away from any steam. Be particularly careful not to touch any hot surfaces especially when running the descale programme or when the front/ top panel is removed.**

## Other safety considerations

- To protect against fire, electric shock and personal injury do not immerse cord, plug or water boiler in water or any other liquid.
- Do not tamper with the connector in any way.
- If the mains lead is damaged, it should be discarded and replaced.
- Turn off and unplug when not in use.
- Maintenance other than cleaning and descaling should be carried out by the manufacturer while this product is within guarantee. (Contact our service helpline on 0870 060 2618).
- Warranty is only valid in the UK.  
IMPORTANT: This appliance must only be used for heating water.

## Electrical requirements

Check that the voltage on the rating plate of your appliance corresponds with your electricity supply which must be A.C. (Alternating Current).

## For appliances fitted with a plug

If the socket outlets are not suitable for the plug supplied with this appliance, the plug should be removed and the appropriate one fitted.

**WARNING: The plug removed from the mains lead, if severed, must be destroyed as a plug with bared flexible cord is hazardous if engaged into a live socket outlet.**

**WARNING: This appliance must be earthed.**

**Should the fuse in the 13A plug require changing, a 13A BS 1362 fuse must be fitted.**

IMPORTANT: Installation must be carried out by an appropriately qualified service engineer. Any damage caused by installation by an un-qualified individual will invalidate your warranty.

## Fitting a plug

The mains lead of this urn will already be fitted with a BS1363 13A plug. In the event of replacing a fuse, a 13 amp fuse approved by ASTA or BSI must be used. If the plug is not suitable for your socket then the plug must be cut off and disposed of safely. An appropriate plug should be fitted as follows:

IMPORTANT: The wires in the mains lead are coloured in accordance with the following code:

Green-and-Yellow - Earth  
Blue - Neutral  
Brown - Live

The wire, which is coloured green and- yellow, must be connected to the terminal in the plug which is marked with the letter E or the earth symbol or coloured green or green-and yellow. The wire, which is coloured blue, must be connected to the terminal which is marked with the letter N or coloured black or blue. The wire, which is coloured brown, must be connected to the terminal which is marked with the letter L or coloured red or brown. Make sure that the connections are tight and that there are no loose strands of wire and no insulation trapped under the terminals. Tighten the clamp in the plug making sure that it grips the outer covering of the cord. In a 13A (BS 1363) fused plug, fit a 13A fuse. Tighten the plug cover securely.

If you are in any doubt, consult a qualified electrician.

IMPORTANT: The supply cord on this appliance is of a special type. If replaced, only a Burco supply cord must be used. The supply cord may become warm when the appliance is in use.

## 6kW Appliances

You must use a qualified electrician to install the 6kW water boilers to an appropriate (32amp) supply. Do not fit a 13amp plug to these boilers. Means of disconnection must be incorporated in the fixed wiring in accordance with the wiring rules.

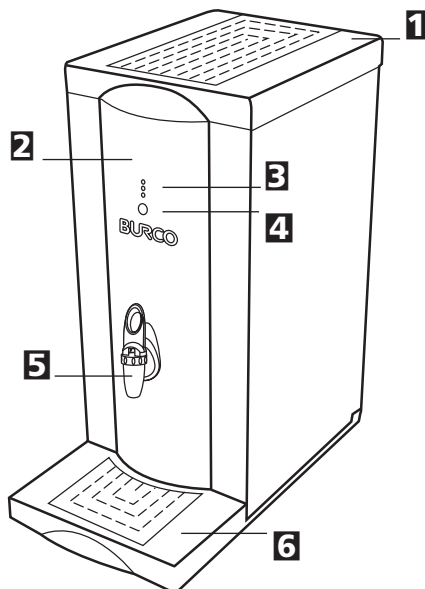
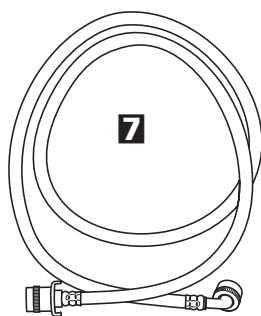

## Features

- 1 Removable lid (Easy access for descaling)
- 2 Removable front cover
- 3 Advanced diagnostics indicator lights (See trouble shooting for details)
- 4 On/Off switch
- 5 Safety locking tap
- 6 Drip tray
- 7 Hose for connection to drinking water

## Preparation

- 1 Remove any plastic film from the water boiler and wipe over all surfaces with a clean cloth.
- 2 Check that the voltage on the rating plate of your appliance corresponds with your electricity supply which must be A.C. (Alternating Current).
- 3 Before using it is recommended that the water boiler is boiled twice, discarding the water each time.

## Check list

- Before starting installation check that you have the following parts:
- Autofill water boiler
  - Drip tray
  - Food safe hose

## Connecting to a water supply

Your water boiler has been supplied with a suitable hose **7** for connection to a drinking water supply. The water supply must have a pressure not exceeding 1000 kilopascals (10 bar) and no lower than 25 kilopascals (0.25 bar). If your water pressure exceeds this, a suitable pressure reduction valve will need to be fitted.

Please ensure that you follow the bye-laws of the water council when installing this product.

Burco cannot be held responsible for water boiler malfunction if the water supply pressure does not confirm as above. If in any doubt consult your water supply company.

The hose supplied with the water boiler is manufactured from materials which have been approved for drinking water and is rated at 10 bar at ambient temperature. It is therefore recommended that the water boiler is only connected to a cold water supply. Your guarantee could be invalidated and water contamination may occur if a hose not supplied by Burco is used. Please note that washing machine hoses are not suitable for use on this water boiler.

## Connection to mains water supply

Your autofill water boiler can be set up so that the mains water connection can either enter your water boiler at the back or the bottom of the unit.

### To set up connection from back of unit:

- Using a screw driver remove blanking plate from back of unit **A**.
- Attach supplied water connection fitting to water inlet (screw fitting) and when secure attach the pipe **B**.
- Tightly attach other end of water connection hose to mains water supply.
- Ensure all pipes are suitably insulated to prevent water supply from freezing.
- If rear overflow is required see instructions below on how to set this up at this point.

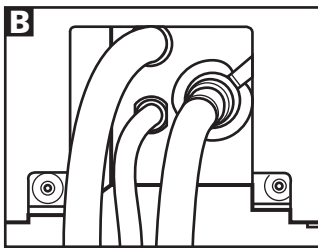
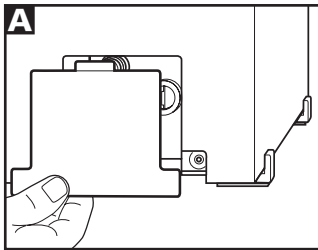

### To set up connection from bottom of unit:

- Using a screw driver remove blanking plate from back of unit **A**.
- Attach supplied water connection hose to water inlet with the elbow joint connection on the hose (screw fitting) **C**.
- Tightly attach other end of water connection hose to mains water supply.
- Replace blanking plate.

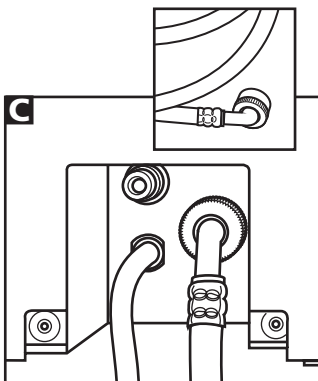

## Overflow

### Connecting rear overflow

An air gap of 200mm from the connection point must be provided. Failure to provide this air gap will cause an air lock and stop the water discharging in event of an overflow.

**IMPORTANT:** For rear overflow connection a 14mm internal diameter hose or a 15mm internal diameter hose with a pipe clip must be used. While every reasonable precaution is taken to prevent an overflow, Burco cannot be held responsible for any damage caused as a result of incorrect installation or blockage of the overflow.

- Attach a suitable 14mm internal diameter or 15mm internal diameter hose with a pipe clip, to outlet connection. (Hose not supplied)
- Attach other end of outlet hose to mains drain.

If connection to the bottom of the water boiler is desired now replace the blanking plate at the back of the unit, using screw driver to tighten in place.

## Connecting your drip tray to the mains drain

**You are able to connect your drip tray to a mains drain inside the counter your autofill water boiler is sitting on. To do this you will require suitable hose and fittings.**

**You will need to follow the below procedure:**

- Check that you have a connection to a suitable mains drain underneath your work top.
- Position your autofill water boiler on your countertop. Remember to leave a space at the back of the unit if you are connecting the unit to the mains water supply/ connecting your overflow to protrude from the back of the unit.  
IMPORTANT: Check that the hose you have is the correct length to reach between mains drain connection and the bottom of the drip tray.
- When you are happy with the boiler position, remove the drip tray from your autofill water boiler, take off the stainless steel drip tray cover.
- If you turn over the remaining section of the drip tray you will see in the centre a raised circle, drill a hole through the centre of this circle. (It is suggested that the drip tray is placed on a surface which you do not mind damaging before you drill the hole, in case the drill goes through the hole and damages the surface underneath.)  
IMPORTANT: The hole you drill will need to be large enough to accommodate the fitting you have purchased.
- Replace the drip tray on your autofill water boiler (still in desired position).
- Do not replace the stainless steel cover so that you are able to mark the position of the hole on the work surface with a suitable marker.
- Remove drip tray and drill hole through work surface in marked location. Before doing this ensure that there is nothing underneath your work top, which you may damage when drilling through the work top.  
IMPORTANT: The hole you drill will need to be large enough to accommodate the hose/ fittings you have purchased.
- Attach hose at mains drain and pull through hole in work surface.
- Leaving enough spare length in the pipe to allow drip tray to be connected, attach connecting fitting to the end of the hose protruding through the work surface. Push connecting valve into the bottom of the drip tray.
- Replace drip tray and stainless steel cover.

## Using

IMPORTANT: Always ensure unit is connected correctly to a water supply and the supply is on before switching the appliance on.

## Operating

**Safety tap.**

- 1 The tap is locked or unlocked by twisting it so that the closed or opened padlock symbol is lined up with the white dot on the tap body.

**General operation.**

- 2 There are two open positions, one self- holding so that the tap remains open, and the other self-closing so that the tap closes as soon as the lever is released. To change the tap position, turn the tap lever through 180°.
- 3 Open the tap by depressing the tap lever into the horizontal position.
- 4 Close the tap by returning the lever to a vertical position.

## After use

Switch off and isolate from supply. Water may be left in the water boiler when it is not in use for short periods, for longer periods it should be emptied and cleaned out.

## Protective cut-out

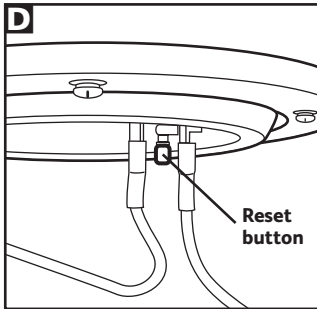

**WARNING: The only parts you should touch behind the front panel are the two red isolation valves. Touching any other part will put you in danger of receiving an electric shock.**

The heating element is fitted with a manual resettable thermal cut out which protects the water boiler from damage if it were to overheat **D**. If your appliance flashes 3 times, fails to heat up, appears 'dead' when switched on try the following:

Check the water boiler is plugged in to the mains and switched on both at the plug/ spur and on the front of the unit. If this does not resolve the problem switch off and disconnect unit, allow to cool, remove front panel (see process below). Reach in carefully and on the underside of the element, between the two terminals you will see/feel a reset button.

Press this upwards and the thermostat will reset. We would always recommend descaling the water boiler after re-setting the thermostat as this is the most common reason for the safety thermostat to have triggered.

If the safety thermostat activates repeatedly, even after descaling, contact the Burco customer helpline.

After resetting the cut-out replace the front panel and top black plastic lid. Reconnect to mains and switch on at plug/spur and on the front of the unit. If the water boiler still appears dead contact Burco helpline.

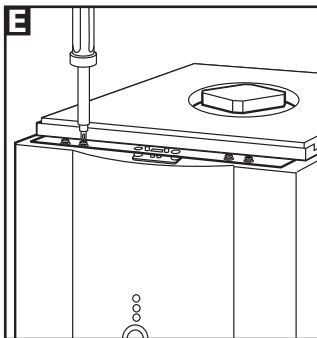

## Cleaning

**WARNING: Disconnect from the electrical supply before cleaning and allow the water boiler to cool.**

**IMPORTANT** Do not immerse the water boiler in water or any other liquids and take care to keep water away from the mains lead and connections.

There are two ways in which you will need to clean your autofill water boiler:

- Externally; to do this follow external cleaning guidelines
- Internally; to do this follow the Easy Descale Procedure below

**IMPORTANT** Do not use any abrasive cleaning fluids or materials.

## External cleaning guidelines

**WARNING: Always disconnect the plug from the mains and allow to cool before cleaning.**

To clean wipe the outside of your autofill water boiler with a damp cloth. It is recommended that this is done daily. Stubborn stains may be removed using a good stainless steel cleaner or non-abrasive cleaner.

Hard to reach areas should be cleaned using a small bristle brush and mild cleaner.

**IMPORTANT:** Do not use abrasive cleaners on your water boiler as this could scratch the finish of your water boiler.

## To remove front panel of unit

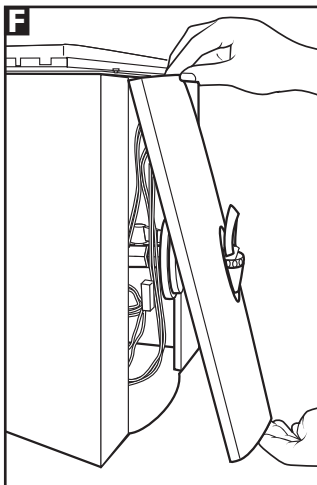

- Remove black plastic lid **1**.
  - Using screw driver remove two retaining screws
  - Lift front panel slightly to disconnect front panel at top of the curved front panel so that hole for the tap goes over the lower part of the top and lift vertically over the rest of the tap **2**.
  - Pull front panel forward while lifting hole for tap over base tap fitting.
  - Lift front panel over top of tap fitting.
- WARNING: When replacing the front of panel, ensure that wires do not get trapped between tap and front panel.**

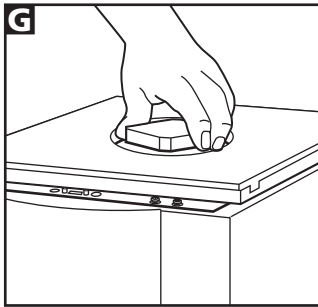

## Easy descale procedure

### When to descale

Burco autofill water boilers are designed to tell you when they require descaling. (See advanced diagnostics below)

Burco recommend that operators should carry out a simple descale as part of the regular planned preventative maintenance schedule at least once per month. When carrying out preventative maintenance follow instructions below for descaling.

### Descaling

When advanced diagnostics lights flash continuously or 6 times between pauses, follow the instructions below.

### When lights on the unit are flashing

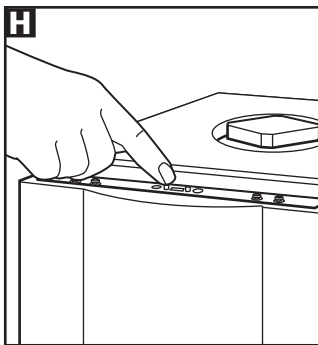

#### 1 Remove lid and prepare unit for descale.

- Remove the black plastic lid **I**
- Unscrew the large, square black cap (anticlockwise) **G**.
- Pour the descale liquid (or powder) straight into the tank of the boiler.
- Press and hold down the left hand small black button labelled "FILL" for 2 seconds, this is found on the top of the boiler **H**.
- Red light next to button should light up, all lights on the front of unit will go out, unit will automatically fill to top probe and heat to a suitable descaling temperature

#### 2 Activate descale cycle and drain through dispensing tap.

- The red light on the top of the unit will start flashing when the boiler is up to temperature, leave unit for 10 minutes (do not leave descaler in water boiler for more than 30 minutes).
- Drain water through main dispensing tap, to ensure tap is descaled as well as the boiler.

- When water stops flowing, close tap.

#### 3 Drain down tank area below tap **I**.

- Take front panel off (see instructions above (page 7)). Connect a hose to the drain down outlet and direct it into a safe vessel or drain to collect/dispense of the remaining water.
- Open tank drain down valve.
- When empty close valve.
- Press right hand button labelled "FLUSH" on top of boiler, lights will illuminate and rinse action should start, unit will fill to top probe.
- When it hits top probe the right hand neon will start to flash again.
- Empty again through tank drain valve as above.
- Ensure drain down valve is closed. Repeat the last 4 steps if additional rinsing is required.

#### 4 Replace front panel and ensure tap is closed.

#### 5 Prepare unit for use.

- Press both 'left' and 'right' buttons together and hold down for 2 seconds **I I**. This resets the descale timer.
- Replace back square cap and screw tightly back on clockwise, firmly **G**.
- Replace black plastic lid **I**.
- Switch unit off and then switch on again.
- Your unit is now descaled and ready to use.

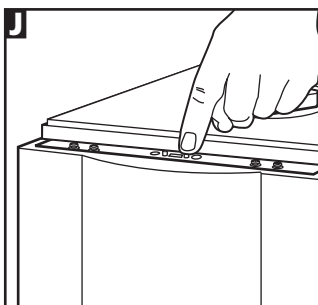
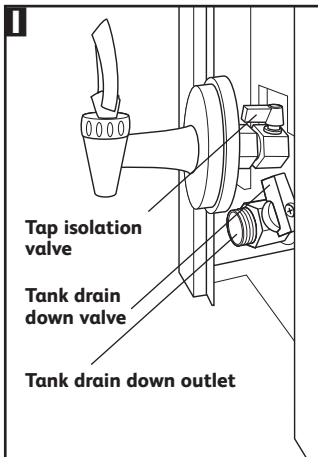



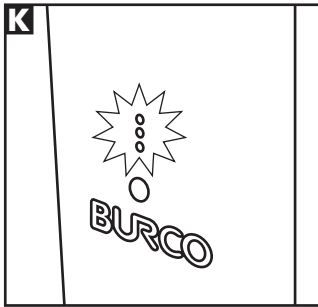

## When red light is constantly on

**WARNING: Disconnect from the mains supply before cleaning and allow the water boiler to cool.**

- Drain 1 litre of water away water using tap.
- Turn unit back on.
- Carry out easy descale procedures above from 1-5.

NOTE: If after decaling the unit the descale lights are still illuminated **K**, turn unit off and wait for unit to cool down fully and all steam to have dispersed, then remove plastic lid, and steam baffle plates carefully.

Check if descale procedure has removed all scale build-up.

IMPORTANT: Before you put your hands into the unit to clean the internal parts you must ensure that the unit is turned off and has fully cooled down.

If scale build up has not all been removed, wipe or scrape away remaining scale with a non-metallic scourer. Ensure you clean the four protruding probes, taking care not to damage any of the internal parts. Replace all parts, turn unit back on and re-run the descale process to ensure all the scale is removed.

IMPORTANT: Do not use a water jet to clean the unit.

IMPORTANT: Do not use any abrasive cleaning fluids or materials.

IMPORTANT: Do not use this appliance in an area a water jet can be used.

If your autofill boiler still does not reset call our Helpline on 0870 060 2618.

## Tap failure

- Scale build up can cause your tap to drip when it is in a closed position. If your tap should fail to operate follow the procedures below:
- Remove front panel of unit. (See procedure on page 7).

**WARNING: The only parts you should touch behind the front panel are the two red isolation valves. Touching any other part will put you in danger of receiving an electric shock.**

- Isolate tap by turning tap isolation valve clockwise
- Unscrew the top of the tap from the body of the tap. If scale is present (white/yellow chalky substance).
- Wipe, scrape and break the scale away from the rubber flexible seal and also from the sealing surface inside the body of the tap.
- Replace top of tap, screwing it firmly back into the base. Open the isolation valve behind tap. If dripping has stopped replace front panel and follow descale process (see above). If tap continues to drip call the Burco customer helpline.

IMPORTANT Failure to de-scale will invalidate your guarantee.

## Trouble shooting

### Advanced diagnostics service light warning codes

INDICATOR LIGHT	CAUSE/PROBLEM	ACTION
Green indicator light.	Power on.	
Amber ready light.	Flashes when heating up On constantly when up to temperature.	
Red indicator constantly on.	Unit has become scaled up, and has shut down to prevent damage to unit.	Descale immediately. (See descale process on page 8.)
Red indicator continuously flashing.	Lower probe has not been detected this may be due to scale build-up.	Descale unit. (See descale process on page 8.)
Red indicator flashes twice.	Upper probe has not been detected, likely scale build-up.	Unit will still operate but needs descaling ASAP. (See descale process on page 8.)
Red indicator flashes 3 times.	Unit below 60°C. Possibly due to boil dry protection or element failure.	Check boil dry thermostat has been reset.
Red indicator flashes 4 times.	Thermostat fault. Element is not heating up.	Contact Helpline.
Red indicator flashes 5 times.	Water is not going into the unit.	Check water pressure, water connection and that water supply is turned on.
Red indicator flashes 6 times.	Your unit has accumulated 2000 hours of operation.	Descale and reset unit.
All lights out.	Unit may be over boiling.	Water temperature adjustment required. Contact Helpline.
PROBLEM	ACTION	
Tap is dripping when closed.	See 'tap failure' guidelines on page 9.	

**Helpline 0870 060 2618**

## Replacement Parts

---

IMPORTANT: This product has no 'user' serviceable parts.  
IMPORTANT: Installation must be carried out by an appropriately qualified service engineer. Any damage caused by installation by an unqualified individual will invalidate your warranty.

Genuine replacement Burco parts must only be fitted by a qualified service engineer. If generic non-Burco parts are fitted you may stop your autofill water boiler operating safely and in the most efficient manner and may invalidate your warranty.

## Helpline 0870 060 2618

---

If you have any difficulty with your appliance, please check the items on the list below:

- Does your autofill water boiler have power going into the unit?
- Have you tried descaling your autofill water boiler?
- Have you pressed reset button?

If you are still having trouble with your appliance please don't hesitate to call us. Please try to have your product to hand and have the following information ready to enable us to deal with your query quickly:

- Name of the product.
- Model number as shown on rating plate, located on the side of the unit.
- Serial number as located on the rating plate, located on the side of the unit.

## Guarantee

---

This water boiler is guaranteed for a period of 12 months from the date of purchase against defective materials or faulty workmanship. This guarantee is given subject to the water boiler being used in accordance with the instructions on the supply voltage marked on it and to the usual fair wear and tear conditions. The guarantee does not cover consequential damage arising out of any failure acceptable under guarantee, nor does it cover damage resulting from misuse, accident or unauthorised alterations to the water boiler.

This guarantee, in no way diminishes the buyer's statutory rights. Please fill in and return the tear off section to register the guarantee with Burco.

*Burco Appliances products are intended for commercial use as detailed in these instructions. We follow a policy of continuous improvement in product quality and design. The company, therefore reserves the right to change the specification of its models at any time.*

# BURCO

### **Burco Appliances Limited**

A MEMBER OF THE GLEN DIMPLEX GROUP

Talbot Road, Mexborough, South Yorkshire, S64 8AJ

Tel 01709 577120 Fax 01709 587510

Email [sales@burco.co.uk](mailto:sales@burco.co.uk)

CP76500MUK