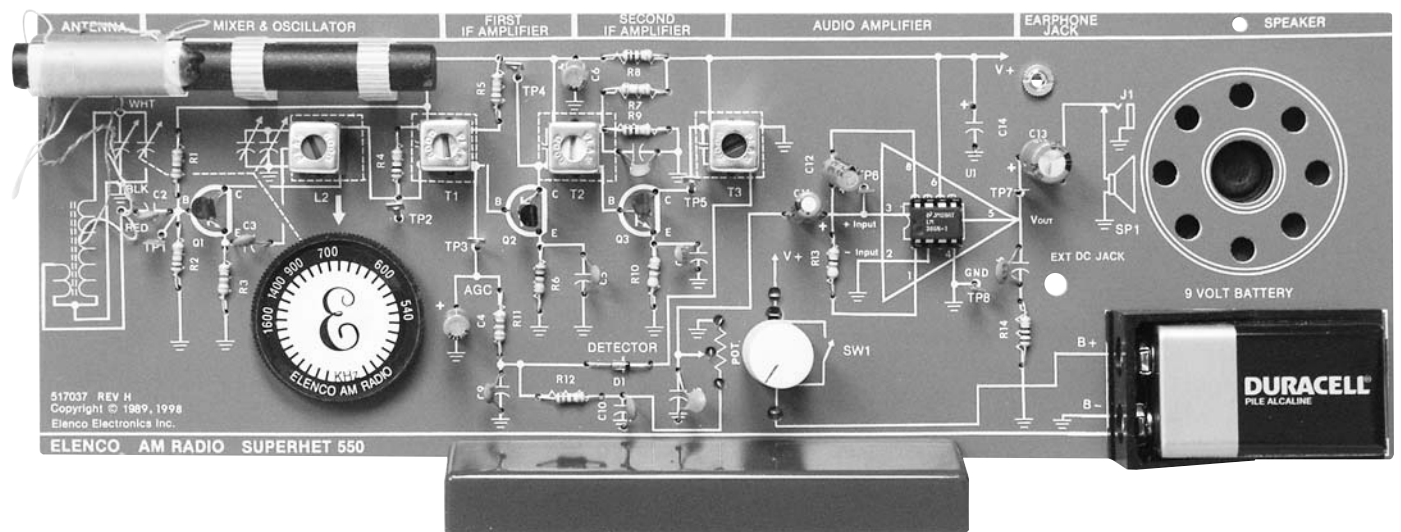


# AM RADIO KIT

## MODEL AM-550K INTEGRAL CIRCUIT, 3 TRANSISTORS, DIODE



7 56619 00103 6



### Assembly and Instruction Manual

# Elenco® Electronics, Inc.

## PARTS LIST

If you are a student, and any parts are missing or damaged, please see instructor or bookstore.

If you purchased this kit from a distributor, catalog, etc., please contact Elenco® Electronics (address/phone/e-mail is at the back of this manual) for additional assistance, if needed. **DO NOT** contact your place of purchase as they will not be able to help you.

### RESISTORS

Qty.	Symbol	Value	Color Code	Part #
<input type="checkbox"/> 1	R14	10Ω 5% 1/4W	brown-black-black-gold	121000
<input type="checkbox"/> 1	R13	47Ω 5% 1/4W	yellow-violet-black-gold	124700
<input type="checkbox"/> 1	R8	100Ω 5% 1/4W	brown-black-brown-gold	131000
<input type="checkbox"/> 1	R10	470Ω 5% 1/4W	yellow-violet-brown-gold	134700
<input type="checkbox"/> 1	R6	1kΩ 5% 1/4W	brown-black-red-gold	141000
<input type="checkbox"/> 1	R12	2.2kΩ 5% 1/4W	red-red-red-gold	142200
<input type="checkbox"/> 2	R3, R11	3.3kΩ 5% 1/4W	orange-orange-red-gold	143300
<input type="checkbox"/> 1	R9	10kΩ 5% 1/4W	brown-black-orange-gold	151000
<input type="checkbox"/> 1	R2	12kΩ 5% 1/4W	brown-red-orange-gold	151200
<input type="checkbox"/> 1	R5	27kΩ 5% 1/4W	red-violet-orange-gold	152700
<input type="checkbox"/> 1	R7	39kΩ 5% 1/4W	orange-white-orange-gold	153900
<input type="checkbox"/> 1	R1	56kΩ 5% 1/4W	green-blue-orange-gold	155600
<input type="checkbox"/> 1	R4	1MΩ 5% 1/4W	brown-black-green-gold	171000
<input type="checkbox"/> 1	Pot/SW1	50kΩ (nut & washer)		192522

### CAPACITORS

Qty.	Symbol	Value	Description	Part #
<input type="checkbox"/> 1	C1	Variable	Tuning	211677
<input type="checkbox"/> 1	C15	.001μF	Discap (102)	231036
<input type="checkbox"/> 2	C3, C10	.01μF	Discap (103)	241031
<input type="checkbox"/> 5	C2, C5, C7, C8, C9	.02μF or .022μF	Discap (203) or (223)	242010
<input type="checkbox"/> 1	C16	.047μF	Discap (473)	244780
<input type="checkbox"/> 3	C4, C11, C12	10μF	Electrolytic Radial (Lytic Capacitor)	271045
<input type="checkbox"/> 1	C6	100μF	Electrolytic Radial (Lytic Capacitor)	281044
<input type="checkbox"/> 2	C13, C14	470μF	Electrolytic Radial (Lytic Capacitor)	284743

### SEMICONDUCTORS

Qty.	Symbol	Description	Part #
<input type="checkbox"/> 1	D1	1N4148 Diode	314148
<input type="checkbox"/> 3	Q1, Q2, Q3	2N3904 Transistor NPN	323904
<input type="checkbox"/> 1	U1	LM-386 Integrated Circuit	330386

### COILS

Qty.	Symbol	Description	Part #
<input type="checkbox"/> 1	L2	Oscillator (red dot)	430057
<input type="checkbox"/> 1	T1	IF (yellow dot)	430260
<input type="checkbox"/> 1	T2	IF (white dot)	430262
<input type="checkbox"/> 1	T3	Detector (black dot)	430264
<input type="checkbox"/> 1	L1	Antenna with Holders	484004


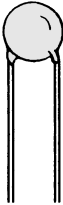

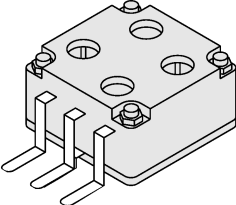

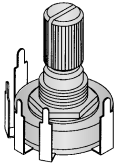

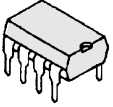
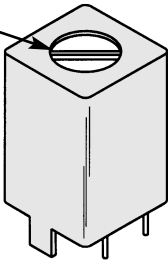
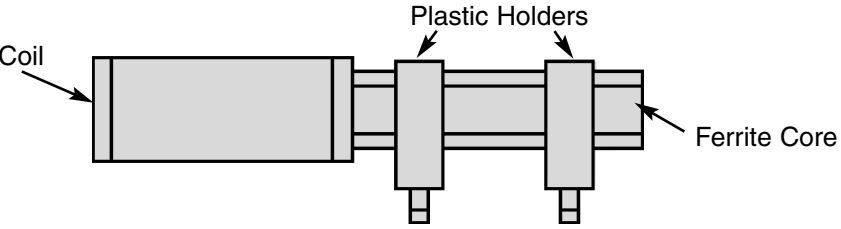
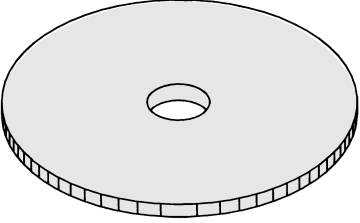
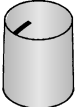
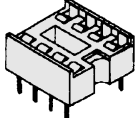
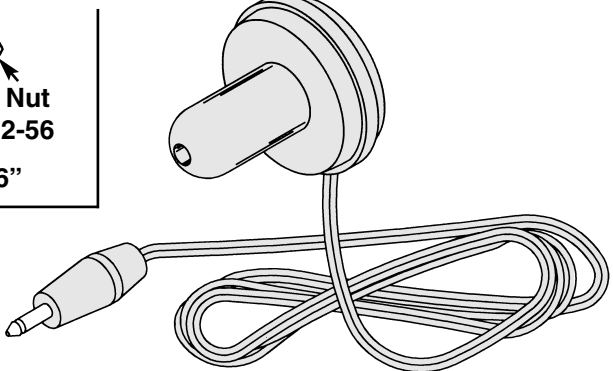




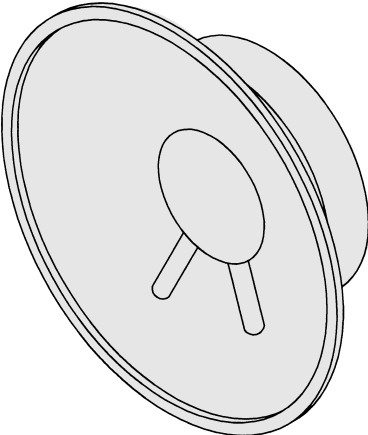
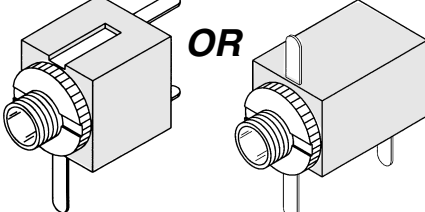

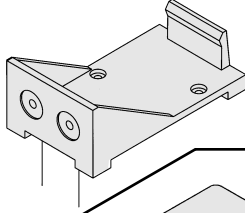
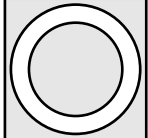

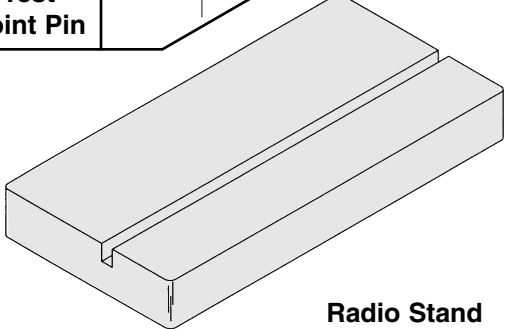
### MISCELLANEOUS

Qty.	Description	Part #	Qty.	Description	Part #
<input type="checkbox"/> 1	PC Board	517037	<input type="checkbox"/> 3	Screw M2.5 x 3.8mm	641310
<input type="checkbox"/> 1	Battery Holder	590096	<input type="checkbox"/> 4	Nut 2-56	644201
<input type="checkbox"/> 1	Speaker	590102	<input type="checkbox"/> 1	IC Socket 8-Pin	664008
<input type="checkbox"/> 1	Knob (pot)	622017	<input type="checkbox"/> 8	Test Point Pin	665008
<input type="checkbox"/> 1	Knob (dial)	622030	<input type="checkbox"/> 1	Label, Dial Knob	720421
<input type="checkbox"/> 1	Earphone Jack with Nut	622130 or 622131	<input type="checkbox"/> 1	Manual	752550
<input type="checkbox"/> 1	Radio Stand	626100	<input type="checkbox"/> 1	Speaker Pad	780128
<input type="checkbox"/> 1	Earphone	629250	<input type="checkbox"/> 1	Wire 4"	814920
<input type="checkbox"/> 3	Screw 2-56 x 1/4"	641230	<input type="checkbox"/> 1	Solder Lead-Free	9LF99
<input type="checkbox"/> 1	Screw 2-56 x 5/16"	641231			

Punch out one antenna shim from the front flap of the box.

**\*\*\*\* SAVE THE BOX THAT THIS KIT CAME IN. IT WILL BE USED ON PAGES 24 & 29. \*\*\*\***

# PARTS IDENTIFICATION

RESISTORS	CAPACITORS			SEMICONDUCTORS	
 <p>Resistor</p>	 <p>Discap</p>	 <p>Electrolytic Radial</p>	 <p>Tuning</p>	 <p>Diode</p>	
 <p>50kΩ Potentiometer with Switch</p>				 <p>Transistor</p>	 <p>LM-386 IC</p>
 <p>Color Dot</p> <p>Coil</p>		<p><b>COILS</b></p>  <p>Coil</p> <p>Plastic Holders</p> <p>Ferrite Core</p> <p>Antenna Assembly</p>			
<p><b>MISCELLANEOUS</b></p>					
 <p>Knob (dial)</p>	 <p>Knob (pot)</p>		 <p>IC Socket</p>		 <p>Earphone</p>
	 <p>Screw M2.5 x 3.8mm</p>		 <p>Screw 2-56 x 1/4"</p>		 <p>Nut 2-56</p>
	 <p>Screw 2-56 x 5/16"</p>				
 <p>Speaker</p>	 <p>Earphone Jack with Nut</p>		 <p>Test Point Pin</p>	 <p>Battery Holder</p>	
	 <p>Speaker Pad</p>	 <p>Label, Dial Knob</p>		 <p>Radio Stand</p>	

## IDENTIFYING RESISTOR VALUES

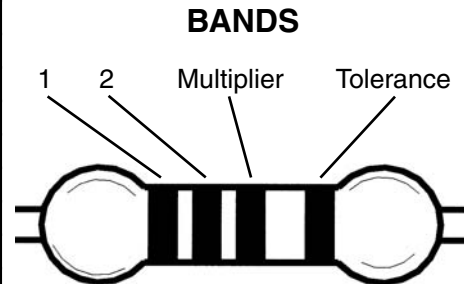
Use the following information as a guide in properly identifying the value of resistors.

BAND 1 1st Digit	
Color	Digit
Black	0
Brown	1
Red	2
Orange	3
Yellow	4
Green	5
Blue	6
Violet	7
Gray	8
White	9

BAND 2 2nd Digit	
Color	Digit
Black	0
Brown	1
Red	2
Orange	3
Yellow	4
Green	5
Blue	6
Violet	7
Gray	8
White	9

Multiplier	
Color	Multiplier
Black	1
Brown	10
Red	100
Orange	1,000
Yellow	10,000
Green	100,000
Blue	1,000,000
Silver	0.01
Gold	0.1

Resistance Tolerance	
Color	Tolerance
Silver	±10%
Gold	±5%
Brown	±1%
Red	±2%
Orange	±3%
Green	±0.5%
Blue	±0.25%
Violet	±0.1%



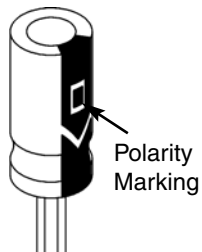
## IDENTIFYING CAPACITOR VALUES

Capacitors will be identified by their capacitance value in pF (picofarads), nF (nanofarads), or  $\mu$ F (microfarads). Most capacitors will have their actual value printed on them. Some capacitors may have their value printed in the following manner. The maximum operating voltage may also be printed on the capacitor.

Electrolytic capacitors have a positive and a negative electrode. The negative lead is indicated on the packaging by a stripe with minus signs and possibly arrowheads.

### Warning:

If the capacitor is connected with incorrect polarity, it may heat up and either leak, or cause the capacitor to explode.



Multiplier	For the No.	0	1	2	3	4	5	8	9
	Multiply By	1	10	100	1k	10k	100k	.01	0.1

Second Digit → Multiplier

First Digit → Tolerance\*



Maximum Working Voltage

The value is  $10 \times 1,000 = 10,000\text{pF}$  or  $.01\mu\text{F}$  100V

\*The letter M indicates a tolerance of  $\pm 20\%$   
 The letter K indicates a tolerance of  $\pm 10\%$   
 The letter J indicates a tolerance of  $\pm 5\%$

**Note:** The letter "R" may be used at times to signify a decimal point; as in 3R3 = 3.3

## METRIC UNITS AND CONVERSIONS

Abbreviation	Means	Multiply Unit By	Or
p	Pico	.000000000001	$10^{-12}$
n	nano	.000000001	$10^{-9}$
$\mu$	micro	.000001	$10^{-6}$
m	milli	.001	$10^{-3}$
-	unit	1	$10^0$
k	kilo	1,000	$10^3$
M	mega	1,000,000	$10^6$

1. 1,000 pico units	= 1 nano unit
2. 1,000 nano units	= 1 micro unit
3. 1,000 micro units	= 1 milli unit
4. 1,000 milli units	= 1 unit
5. 1,000 units	= 1 kilo unit
6. 1,000 kilo units	= 1 mega unit

## INTRODUCTION

The Elenco® Superhet 550 AM Radio Kit is a “superheterodyne” receiver of the standard AM (amplitude modulation) broadcast frequencies. The unique design of the Superhet 550 allows you to place the parts over their corresponding symbol in the schematic drawing on the surface of the printed circuit board during assembly. This technique maximizes the learning process while keeping the chances of an assembly error at a minimum. It is very important, however, that good soldering practices are used to prevent bad connections. The Soldering Guide should be reviewed before any soldering is attempted.

The actual assembly is broken down into five sections. The theory of operation for each section, or

stage, should be read before the assembly is started.

This will provide the student with an understanding of what that stage has been designed to accomplish, and how it actually works. After each assembly, you will be instructed to make certain tests and measurements to prove that each section is functioning properly. If a test fails to produce the proper results, a troubleshooting guide is provided to help you correct the problem. If test equipment is available, further measurements and calculations are demonstrated to allow each student to verify that each stage meets the engineering specifications. After all of the stages have been built and tested, a final alignment procedure is provided to peak the performance of the receiver and maximize the Superhet 550’s reception capabilities.

## GENERAL DISCUSSION

The Superhet 550 can best be understood by analysis of the block diagram shown in Figure 1.

The purpose of section 1, the Audio Amplifier Stage, is to increase the power of the audio signal received from the detector to a power level capable of driving the speaker. Section 2 includes the detector circuit and the AGC (automatic gain control) circuit. The detector converts the amplitude modulated IF (intermediate frequency) signal to a low level audio signal. The AGC stage feeds back a DC voltage to the first IF amplifier in order to maintain a near constant level of audio at the detector. Section 3 is the second IF amplifier. The second IF amplifier is tuned to 455kHz (Kilohertz) and has a fixed gain at this frequency of 100. The 3dB bandwidth of this

stage should be approximately 6kHz. Section 4 is the first IF amplifier which has a variable gain that depends on the AGC voltage received from the AGC stage. The first IF amplifier is also tuned to 455kHz and has a 3dB bandwidth of approximately 6kHz. Section 5 includes the mixer, oscillator and antenna stages. When the radio wave passes through the antenna, it induces a small voltage across the antenna coil. This voltage is coupled to the mixer, or converter, stage to be changed to a frequency of 455kHz. This change is accomplished by mixing (heterodyning) the radio frequency signal with the oscillator signal. Each of these blocks will be explained in detail in the Theory of Operation given before the assembly instructions for that stage.

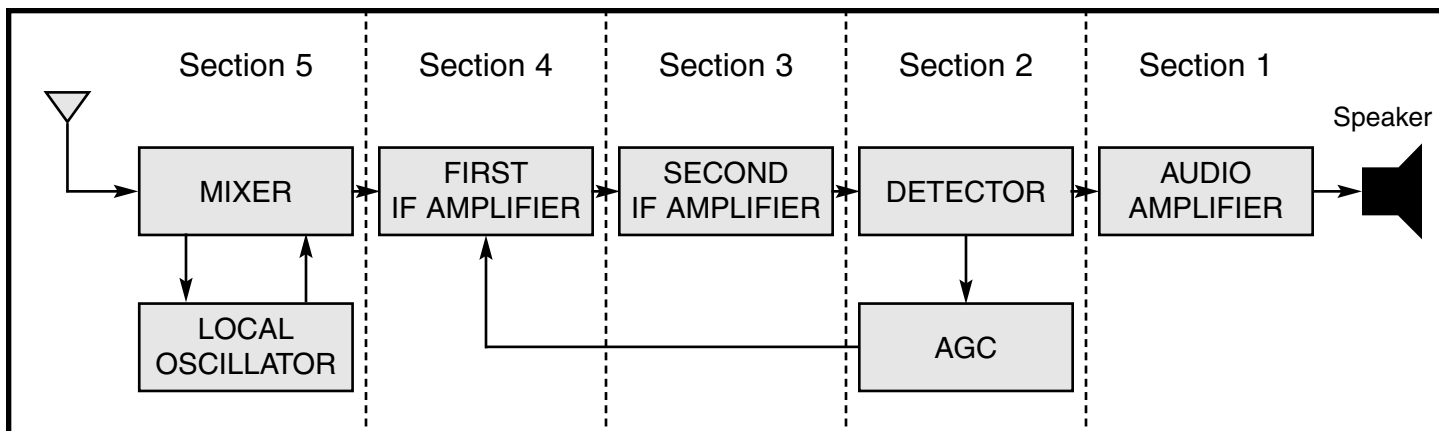


Figure 1

# CONSTRUCTION

## Introduction

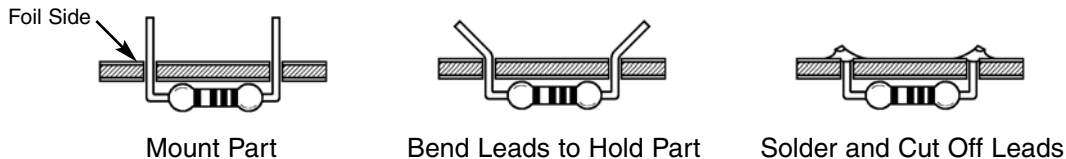
Assembly of your AM-550 AM Radio Kit will prove to be an exciting project and give you much satisfaction and personal achievement. If you have experience in soldering and wiring techniques, then you should have no problem with the assembly of this kit. Care must be given to identifying the proper components and in good soldering habits. Above all, take your time and follow these easy step-by-step instructions. Remember, "An ounce of prevention is worth a pound of cure". Avoid making mistakes and no problems will occur.

## Safety Procedures

- Wear eye protection when soldering and during all phases of construction.
- Locate soldering iron in an area where you do not have to go around it or reach over it.
- Do not hold solder in your mouth. Wash your hands thoroughly after handling solder.
- Be sure that there is adequate ventilation present.

## Assemble Components

In all of the following assembly steps, the components must be inserted on the top side of the PC board unless otherwise indicated. The top legend shows where each component goes. The leads pass through the corresponding holes and the board is turned to solder the component leads on the foil side. Solder immediately unless the pad is adjacent to another hole which will interfere with the placement of the other component. Cut excessive leads with a diagonal cutter. Then, place a check mark in the box provided next to each step to indicate that the step is completed. Be sure to save the extra leads for use as jumper wires if needed.



- Rx - 100Ω 5% 1/4W Resistor  
(brown-black-brown-gold)

## Soldering

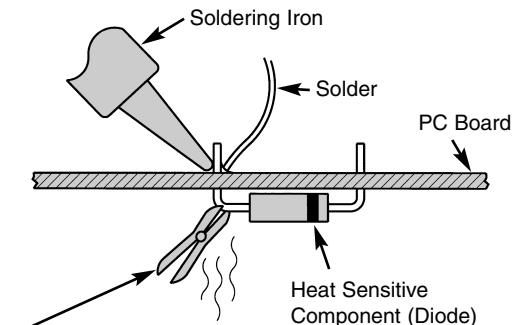
The most important factor in assembling your AM radio kit is good soldering techniques. Using the proper soldering iron is of prime importance. A small pencil type soldering iron of 25 - 40 watts is recommended. **The tip of the iron must be kept clean at all times and well tinned.** Many areas on the PC board are close together and care must be given not to form solder shorts. Size and care of the tip will eliminate problems.

For a good soldering job, the areas being soldered must be heated sufficiently so that the solder flows freely. Apply the solder simultaneously to the component lead and the component pad on the PC board so that good solder flow will occur. Be sure that the lead extends through the solder smoothly indicating a good solder joint. **Use only rosin core solder.**

**DO NOT USE ACID CORE SOLDER!** Do not blob the solder over the lead because this can result in a cold solder joint.

## Heat Sinking

Electronic components such as transistors, IC's, and diodes can be damaged by the heat during soldering. Heat sinking is a way of reducing the heat on the components while soldering. Dissipating the heat can be achieved by using long nose pliers, an alligator clip, or a special heat dissipating clip. The heat sink should be held on the component lead between the part and the solder joint.



Heat Sink (this can be ordered as part of Elenco's Solder Ease Kit Model SE-1).

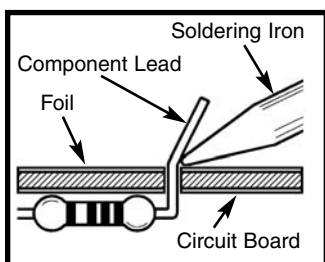
A poorly soldered joint can greatly affect small current flow in circuits and can cause equipment failure. You can damage a PC board or a component with too much heat or cause a cold solder joint with insufficient heat. Sloppy soldering can cause bridges between two adjacent foils preventing the circuit from functioning.

## What Good Soldering Looks Like

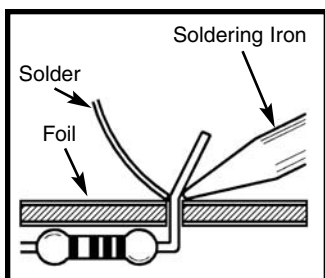
A good solder connection should be bright, shiny, smooth, and uniformly flowed over all surfaces.

### Soldering a PC board

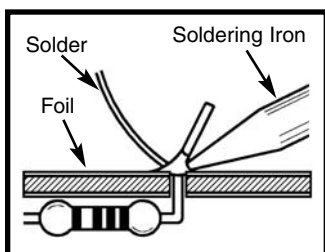
1. Solder all components from the copper foil side only. Push the soldering iron tip against both the lead and the circuit board foil.



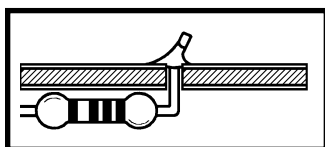
2. Apply a small amount of solder to the iron tip. This allows the heat to leave the iron and onto the foil. Immediately apply solder to the opposite side of the connection, away from the iron. Allow the heated component and the circuit foil to melt the solder.



3. Allow the solder to flow around the connection. Then, remove the solder and the iron and let the connection cool. The solder should have flowed smoothly and not lump around the wire lead.

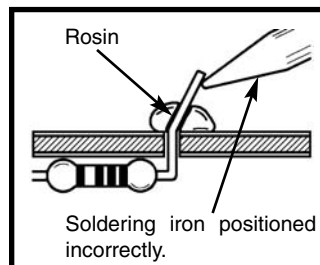


4. Here is what a good solder connection looks like.

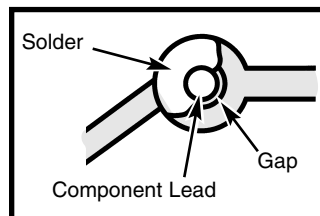


## Types of Poor Soldering Connections

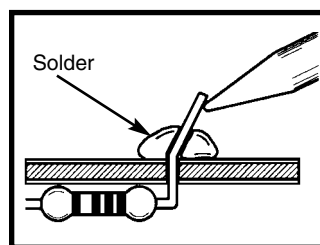
1. **Insufficient heat** - the solder will not flow onto the lead as shown.



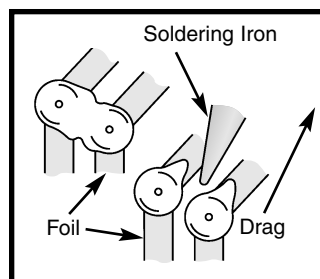
2. **Insufficient solder** - let the solder flow over the connection until it is covered. Use just enough solder to cover the connection.



3. **Excessive solder** - could make connections that you did not intend to between adjacent foil areas or terminals.



4. **Solder bridges** - occur when solder runs between circuit paths and creates a short circuit. This is usually caused by using too much solder. To correct this, simply drag your soldering iron across the solder bridge as shown.



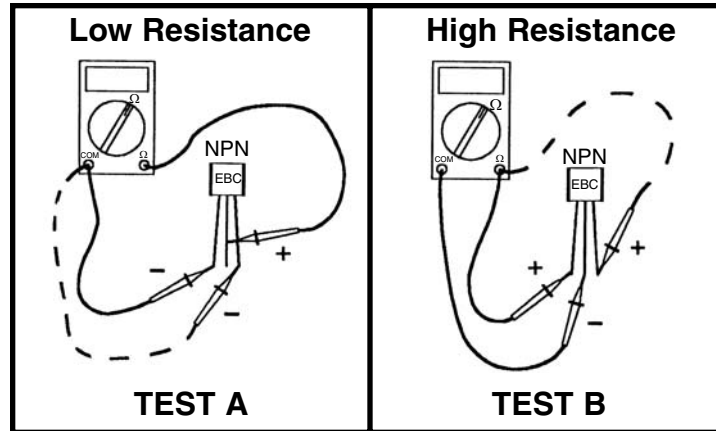
# SEMICONDUCTOR PARTS FAMILIARIZATION

This section will familiarize you with the proper method used to test the transistors and the diode.

## TRANSISTOR TEST

Refer to the parts list and find transistors. These are NPN transistors. Refer to Test A for locating the Emitter, Base and Collector. Using an Ohmmeter, connect the transistor as shown in Test A. Your meter should be reading a low resistance. Switch the lead from the Emitter to the Collector. Your meter should again be reading a low resistance.

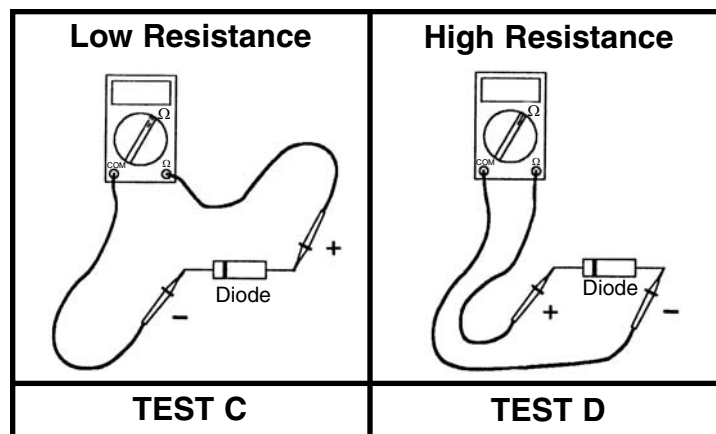
Using an Ohmmeter, connect the transistor as shown in Test B. Your meter should be reading a high resistance. Switch the lead from the Emitter to the Collector. Your meter should again be reading a high resistance. Typical results read approximately  $1M\Omega$  to infinity.



## DIODE TEST

Refer to the parts list and find a diode. This is a silicon 1N4148 diode. Refer to Test C for locating the Cathode and Anode. The end with the band is the cathode. Using an Ohmmeter, connect the diode as shown in Test C. Your meter should be reading a low

resistance. Using an Ohmmeter, connect the diode as shown in Test D. Your meter should be reading a high resistance. Typical results read approximately  $1M\Omega$  to infinity.





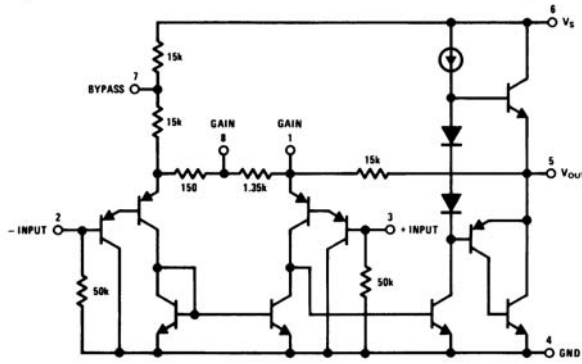
# SECTION 1

## AUDIO AMPLIFIER

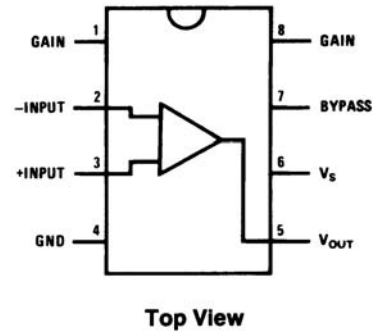
The purpose of the Audio Amplifier is to increase the audio power to a level sufficient to drive an 8 ohm speaker. To do this, DC (direct current) from the battery is converted by the amplifier to an AC (alternating current) in the speaker. The ratio of the power delivered to the speaker and the power taken from the battery is the efficiency of the amplifier. For the Audio Amplifier, we use the integrated circuit (IC) LM-386. In Figure 2, you can see equivalent schematic and connection diagrams. In a Class A amplifier (transistor on over entire cycle), the maximum theoretical efficiency is .5 or 50%. But, in a Class B

**Equivalent Schematic and Connection Diagrams**

**Figure 2**



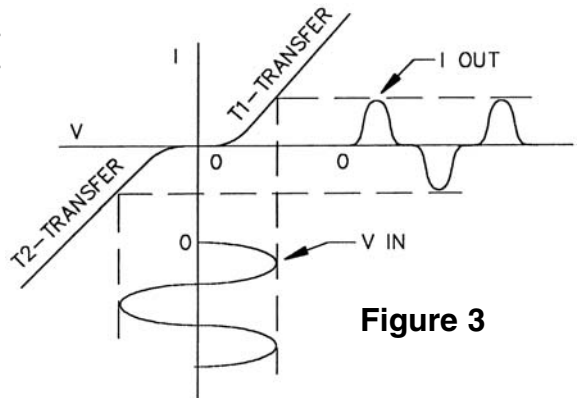
**Dual-In-Line and Small Outline Packages**



amplifier (transistor on for 1/2 cycle), the maximum theoretical efficiency is .785 or 78.5%. Since transistor characteristics are not ideal in a pure Class B amplifier, the transistors will introduce crossover distortion. This is due to the non-linear transfer curve near zero current or cutoff. This type of distortion is shown in Figure 3.

In order to eliminate crossover distortion and maximize efficiency, the transistors of the audio amplifier circuit are biased on for slightly more than 1/2 of the cycle, Class AB. In other words, the transistors are working as Class A amplifiers for very small levels of power to the speaker, but they slide toward Class B operation at larger power levels.

To make the LM-386 a more versatile amplifier, two pins (1 and 8) are provided for gain control. With pins 1 and 8 open, the 1.35kΩ resistor sets the gain at 20 (see Figure 4a). The gain will go up to 200 (see Figure 4b) if a resistor is placed in series with the capacitor. The gain can be set to any value from 20 to 200. The amplifier with a gain of 50 is shown in Figure 4c.

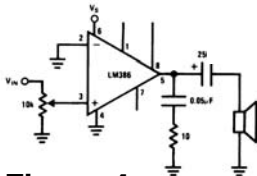


**Figure 3**

The amplifier in our kit with a gain of 150 is shown in Figure 5. Capacitor C11 couples the audio signal from the volume control to the input of the audio amplifier. Capacitor C13 blocks the DC to the speaker, while allowing the AC to pass.

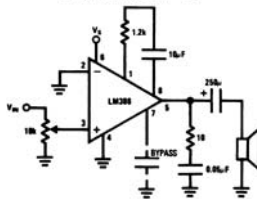
**Typical Applications**

**Amplifier with Gain = 20  
Minimum Parts**



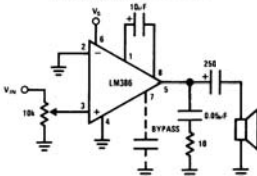
**Figure 4a**

**Amplifier with Gain = 50**

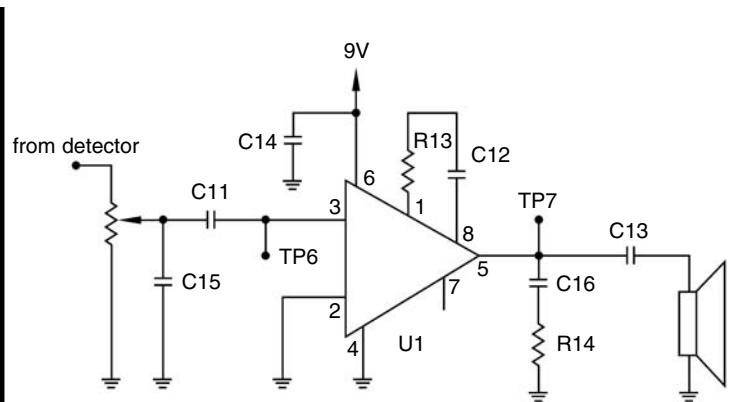


**Figure 4c**

**Amplifier with Gain = 200**



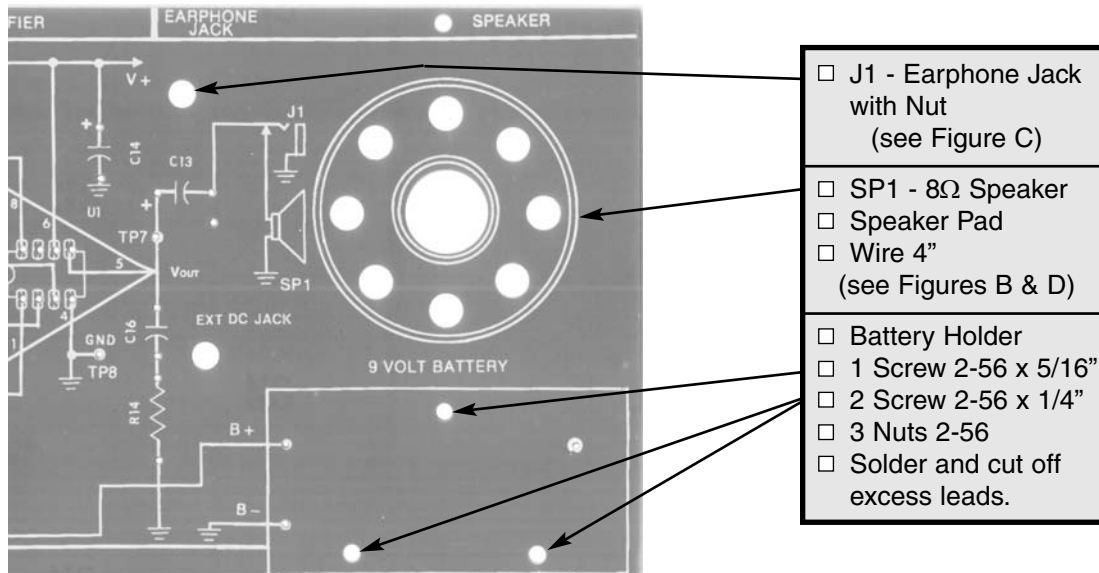
**Figure 4b**



**Figure 5**

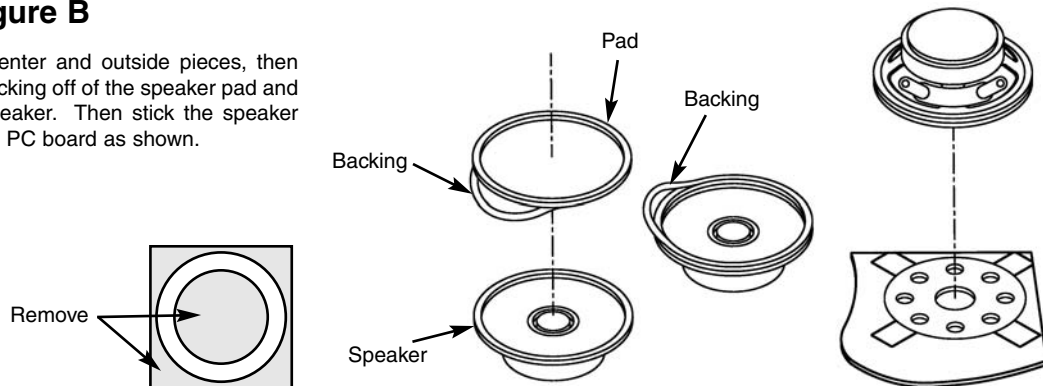
# ASSEMBLY INSTRUCTIONS

We will begin by installing the speaker. Be careful to properly mount and solder all components. Diodes and electrolytic capacitors are polarized, be sure to follow the instructions carefully so that they are not mounted backwards. Check the box when you have completed each installation.



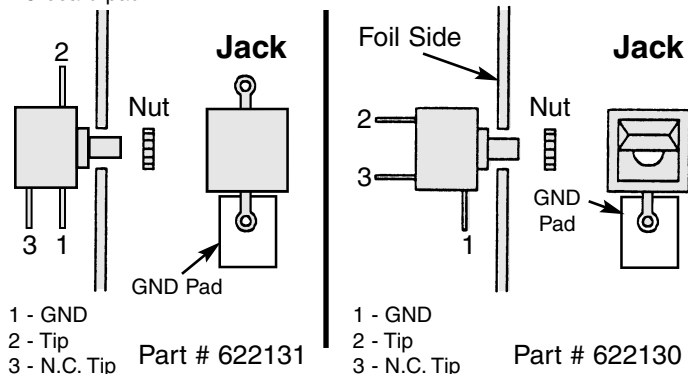
**Figure B**

If the speaker pad has center and outside pieces, then remove them. Peel the backing off of the speaker pad and stick the pad onto the speaker. Then stick the speaker onto the solder side of the PC board as shown.



**Figure C**

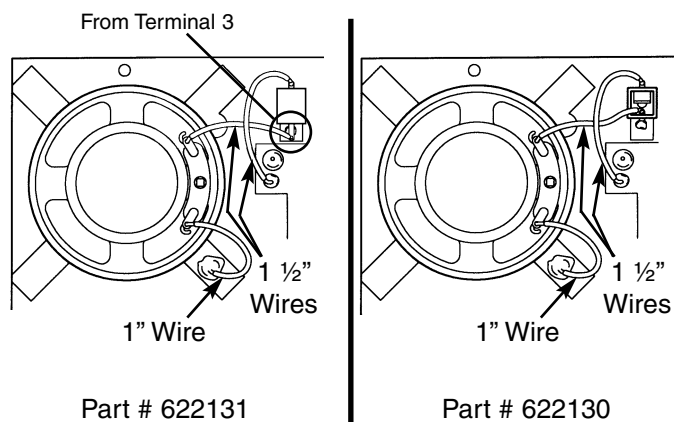
Your kit may contain a different type of earphone jack. Before installing the jack, determine which one you have. Solder the GND terminal to the PC board pad.



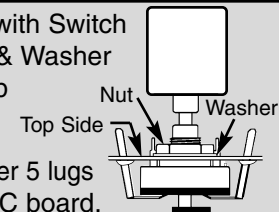
Mount the jack with the nut from the foil side of the PC board (terminal #1 on the GND pad of the PC board). Be sure to line up the tab with the pad on the copper side of the PC board. Solder terminal #1 to the pad of the PC board.

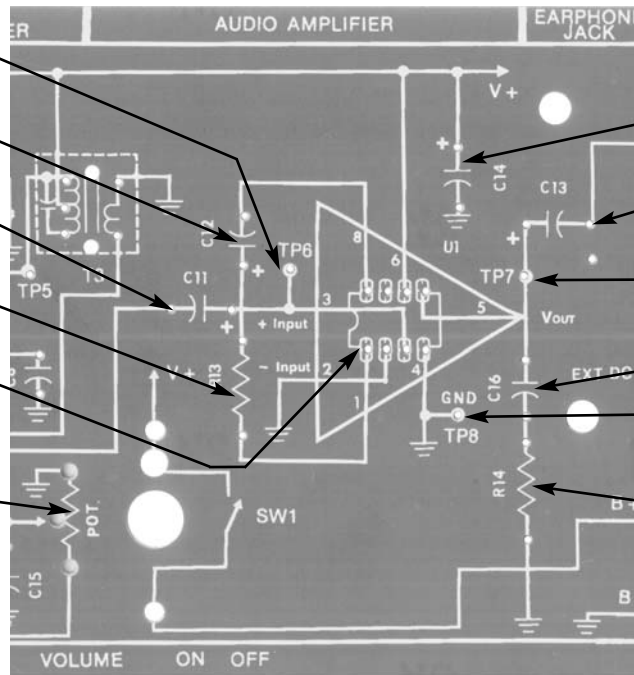
**Figure D**

Cut two 1 1/2" wires and one 1" wire and strip 1/4" of insulation off of both ends. Solder the wires in the locations shown.

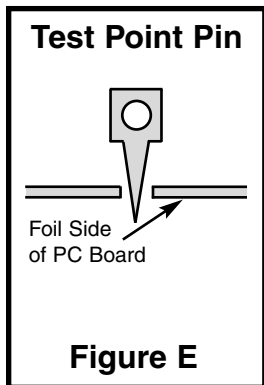


# ASSEMBLY INSTRUCTIONS

- TP6 - Test Point Pin  
(see Figure E)
  - C12 - 10 $\mu$ F Lytic Capacitor  
(see Figure F)
  - C11 - 10 $\mu$ F Lytic Capacitor  
(see Figure F)
  - R13 - 47 $\Omega$  5% 1/4W Resistor  
(yellow-violet-black-gold)
  - U1 - IC Socket 8-Pin  
 U1 - Integrated Circuit LM-386  
(see Figure I)
  - Pot with Switch  
 Nut & Washer  
 Knob
- 
- Solder 5 lugs to PC board.

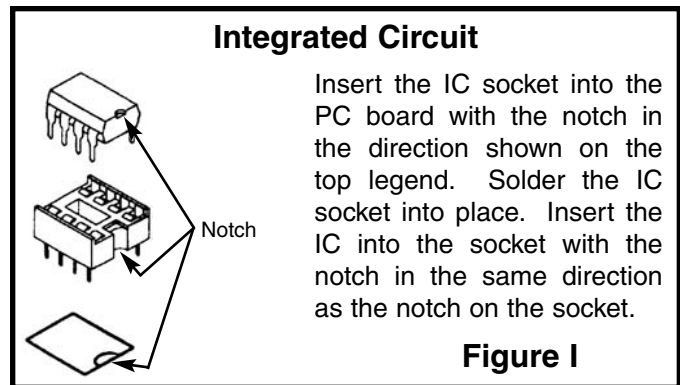
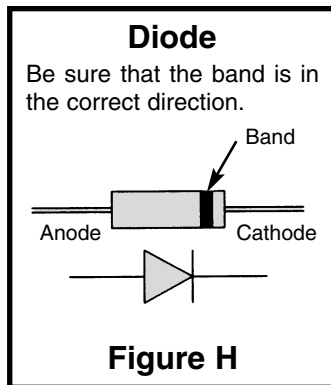
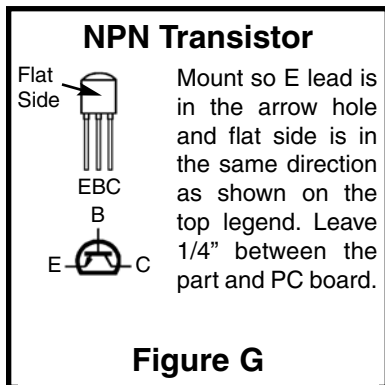
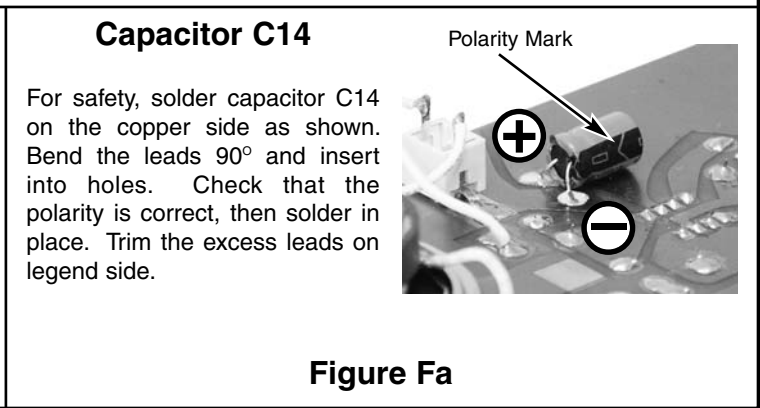
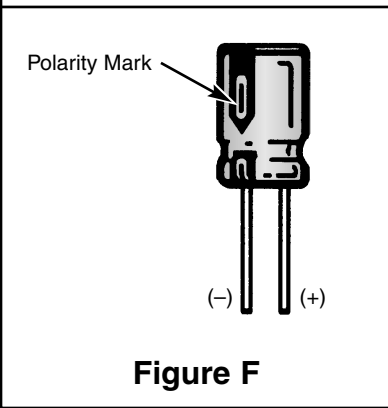


- C14 - 470 $\mu$ F Lytic Capacitor  
(see Figure Fa)
- C13 - 470 $\mu$ F Lytic Capacitor  
(see Figure F)
- TP7 - Test Point Pin  
(see Figure E)
- C16 - .047 $\mu$ F (473) Discap
- TP8 - Test Point Pin  
(see Figure E)
- R14 - 10 $\Omega$  5% 1/4W Resistor  
(brown-black-black-gold)



Electrolytics have a polarity marking indicating the (-) lead. The PC board is marked to show the lead position.

**Warning:** If the capacitor is connected with incorrect polarity, or if it is subjected to voltage exceeding its working voltage, it may heat up and either leak or cause the capacitor to explode.



You have completed wiring the Audio Amplifier. We shall proceed in testing this circuit. You will need for static measurements, a Volt-Ohm-Milliammeter, preferably a digital type.

## STATIC MEASUREMENTS

### RESISTANCE TEST

Adjust the Volt-Ohm-Milliammeter (VOM) to the highest resistance scale available. Connect the VOM to pin 6 of the IC as shown in Figure 6. Do not connect the battery. The VOM should indicate a low resistance first and then as C14 charges, resistance should rise to approximately  $4M\Omega$ . If you get a lower reading, reverse

multimeter leads. If you get a reading lower than  $100k\Omega$ , check the circuit for shorts or parts inserted incorrectly. Check C14 to see if it's leaky or inserted backwards. If you get a reading higher than  $10M\Omega$ , check for open copper or bad solder connections on all components.

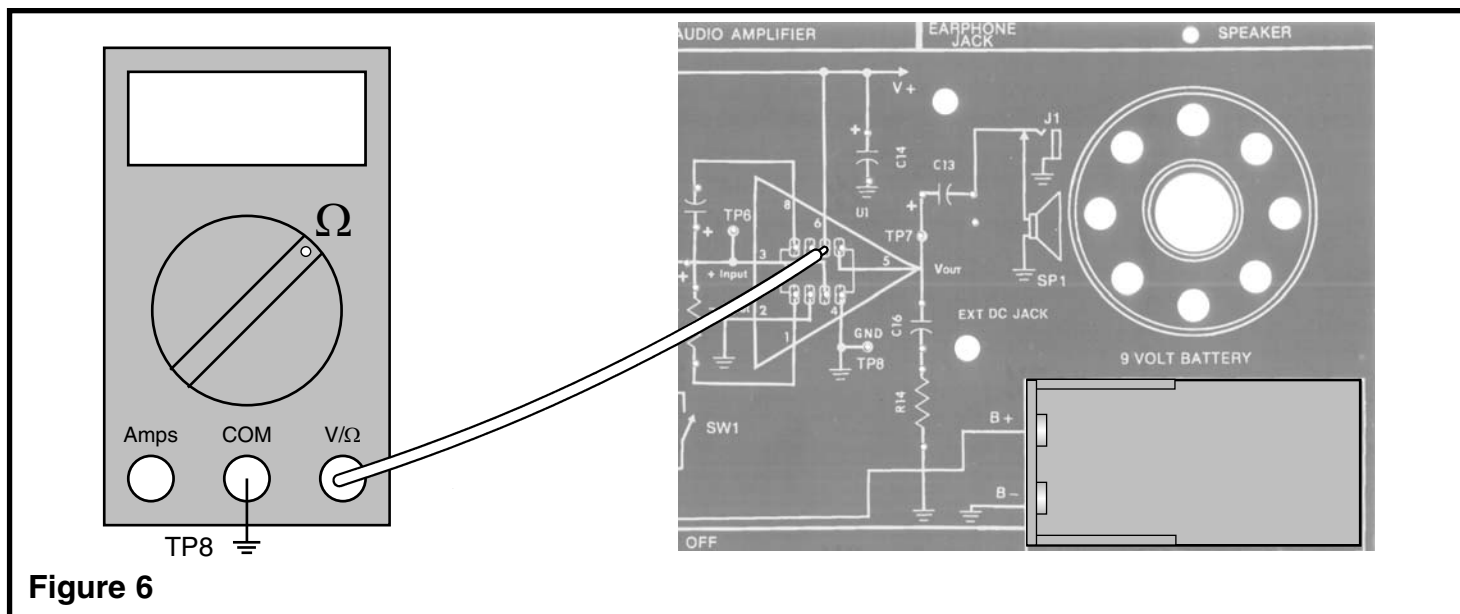


Figure 6

### POWER UP TEST

Set your VOM to read the highest possible current. Connect the meter to the circuit as shown in Figure 7. Make sure that the On/Off switch (SW1) is in the OFF position. While watching your VOM, flip switch SW1 to the ON position. The VOM should indicate a very low current.

Adjust your meter for a more accurate reading if necessary. If the current is greater than 25 milliamps, immediately turn the power off. The current should be between 3 and 15 milliamps. If you circuit fails this test, check that all parts have been installed correctly and check for shorts or poor solder connections. Turn OFF SW1.

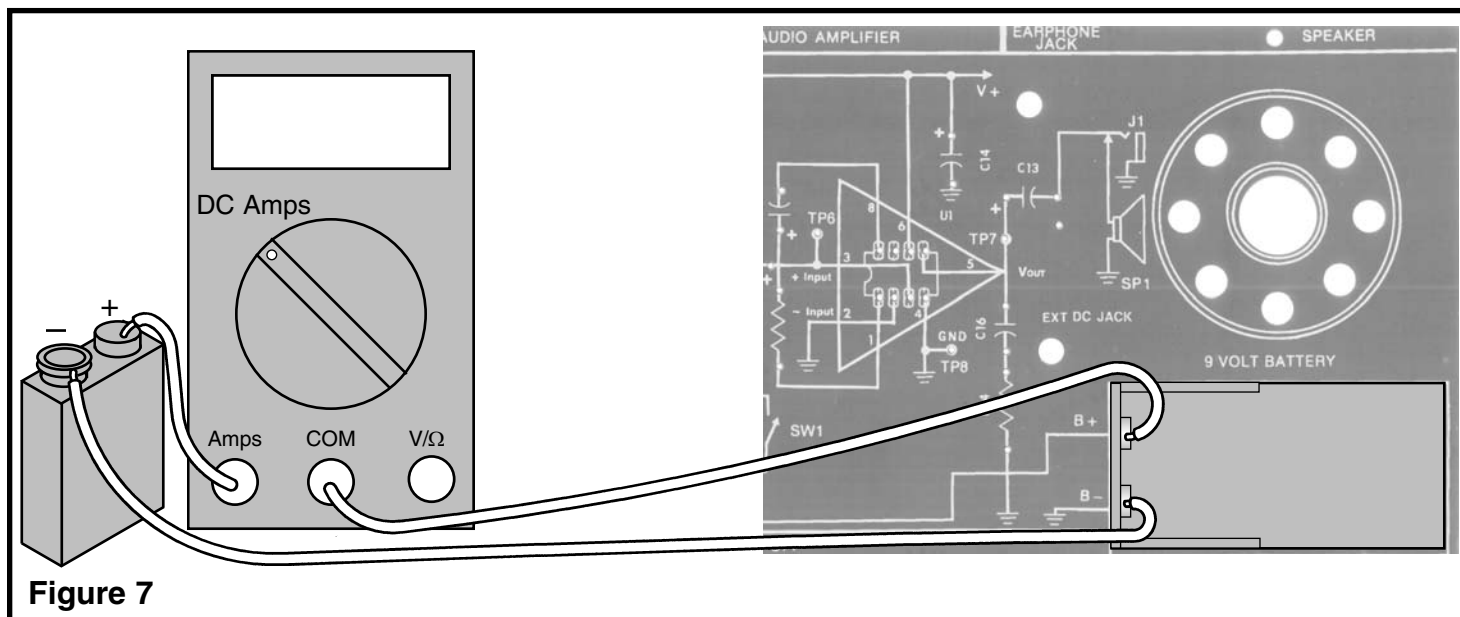


Figure 7

## OUTPUT BIAS TEST

Adjust your VOM to read 9 volts and connect it to test point 7 (TP7) as shown in Figure 8.

Make sure that the battery, or a 9 volt power supply (if available), is properly connected and turn the power ON. The voltage at TP7 should be between 4 to 6 volts. If you get this reading, go on to the next test. If your circuit fails this test, turn the power OFF and check that the integrated circuit is correctly inserted in the correct locations.

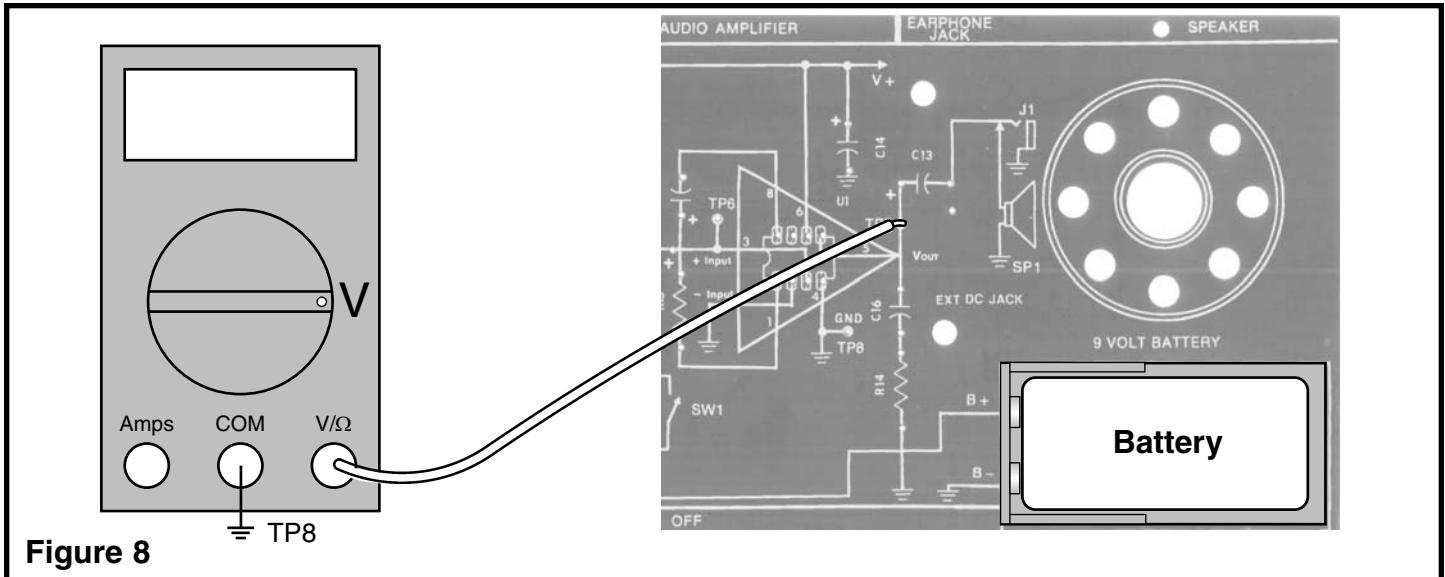


Figure 8

If you do not have an audio generator, skip the following test and go directly to Section 2.

## DYNAMIC MEASUREMENTS

### AC GAIN

Connect the VOM and audio generator to TP6 as shown in Figure 9. Turn the power ON. Normally the AC gain is measured at a frequency of 1 kilohertz (kHz). Your VOM, however, may not be able to accurately read AC voltages at this frequency. It is recommended, therefore, that this test be performed at 400Hz. Set the audio generator at 400Hz and minimum voltage output. Set your VOM to read an AC voltage of 1 volt at the output of your Audio Amplifier (TP7). Slowly increase the output of the audio

generator until the VOM reads 1 volt AC. Leave the audio at this setting and move the positive lead of your VOM to TP6. Record the AC voltage input to the amplifier here:  $V_{in} =$  \_\_\_\_\_ volts. You may have to change scales on your VOM for the most accurate reading. Turn the power OFF. The AC voltage gain of your Audio Amplifier is equal to the AC output voltage divided by the AC input voltage, or  $1/V_{in}$ . Your calculated AC Gain should be approximately 100/180.

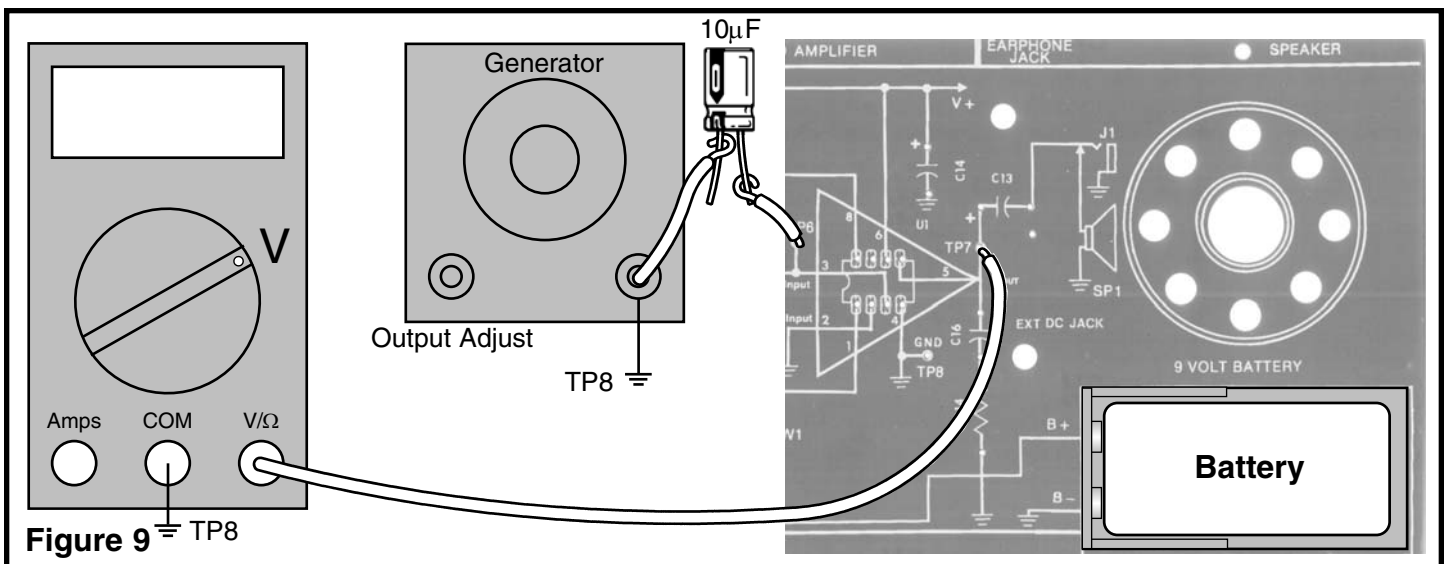


Figure 9

If an oscilloscope is not available, skip the following test and go directly to Section 2.

## DYNAMIC MEASUREMENTS

### AC BANDWIDTH

Connect the oscilloscope and audio generator to your circuit as shown in Figure 10.

Set the audio generator for a frequency of 1kHz and minimum voltage output. Set the oscilloscope to read .5 volts per division. Turn the power ON and slowly increase the generator output until the oscilloscope displays 2 volts peak to peak ( $V_{pp}$ ) at TP7. Move the oscilloscope probe to TP6 and record the input voltage here:  $V_{in} = \text{_____ } V_{pp}$ , (at this point you may want to verify the AC Gain). Move the oscilloscope probe back to TP7 and slowly increase the frequency from the audio generator until the waveform on the oscilloscope drops to .7 of its original reading, 1.4  $V_{pp}$

or 2.8 divisions. Use the oscilloscope probe to check TP6 to make sure the input voltage did not change. The frequency of the generator when the output drops to .7 of its original value is called the high frequency 3 decibel (dB) corner.

Repeat this procedure by lowering the frequency from the generator to obtain the low frequency 3dB corner. Leave the oscilloscope connected to TP7 and turn the power OFF. By subtracting the frequency of the low corner from the frequency of the high corner, you calculate the bandwidth of the Audio Amplifier. Your bandwidth should be greater than 100kHz.

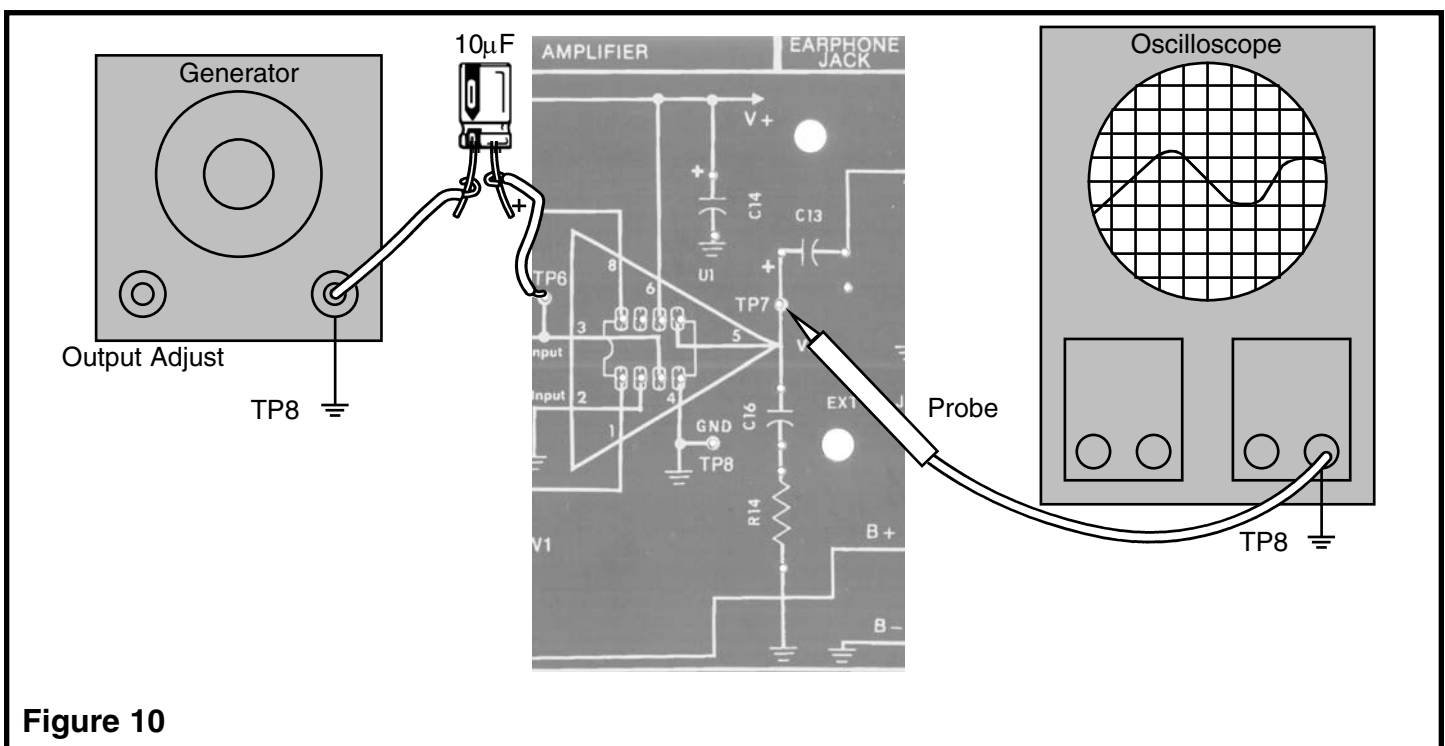
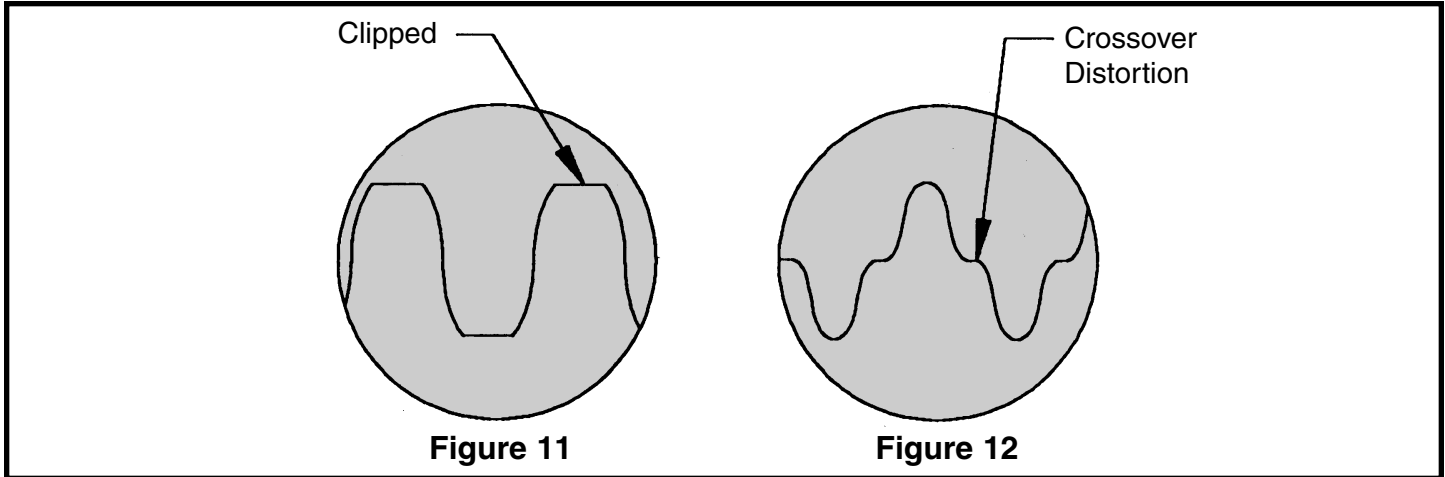


Figure 10

## DISTORTION

Connect the generator and oscilloscope as shown in Figure 10. Set the generator at a frequency of 1kHz, turn the power ON and adjust the generator output

until the peaks of the sinewave at TP7 are clipped as shown in Figure 11.



Measure the maximum voltage peak to peak when clipping first occurs and record that value here:

$$V_{clp} = \text{_____} V_{pp}.$$

## MAXIMUM POWER OUTPUT

The maximum power output before distortion due to “clipping” can be calculated using the voltage  $V_{clp}$  obtained in step 3 as follows:

$$V_{peak} (V_p) = V_{clp}/2$$

$$V_{root\ mean\ squared} (V_{rms}) = V_p \times .7$$

$$\text{Max power out} = (V_{rms})^2/8\ \text{ohms} = (V_{clp} \times .35)^2/8$$

Maximum power output should be greater than 200 milliwatts.

## EFFICIENCY

By measuring the DC power taken from the battery at the maximum power output level, the efficiency to the Audio Amplifier can be calculated. Power from the battery is equal to the current taken from the battery times the voltage of the battery during maximum power output. It is best to use a power

supply to prevent battery voltage from changing during this measurement. Efficiency can then be calculated as follows:

$$\text{Eff} = \frac{\text{Max power output}}{\text{Battery power}}$$

## SECTION 2

### AM DETECTOR AND AGC STAGES

#### THEORY OF OPERATION

The purpose of the detector is to change the amplitude modulated IF signal back to an audio signal. This is accomplished by a process called detection or demodulation. First, the amplitude modulated IF signal is applied to a diode in such a way as to leave only the negative portion of that signal (see Figure 13). The diode acts like an electronic check valve that only lets current pass in the same direction as the arrow (in the diode symbol) points. When the diode is in conduction (On Condition), it will force capacitors C9 and C10 to charge to approximately the same voltage as the negative peak of the IF signal. After conduction stops in the diode (Off Condition), the capacitors will discharge through resistors R11, R12 and the volume control. The discharge time constant for this circuit must be small enough to follow the audio signal or high frequency audio distortion will occur. The discharge time constant must be large enough, however, to remove the intermediate frequency (455kHz) and leave only the audio at the volume control as shown in Figure 13.

The purpose of the automatic gain control (AGC) circuit is to maintain a constant audio level at the detector, regardless of the strength of the incoming signal. Without AGC, the volume control would have to be adjusted for each station and even moderately strong stations would clip in the final IF amplifier causing audio distortion. AGC is accomplished by adjusting the DC bias of the first IF amplifier to lower its gain as the signal strength increases. Figure 13 shows that the audio at the top of the volume control is actually "riding" on a negative DC voltage when strong signals are encountered. This negative DC component corresponds to the strength of the incoming signal. The larger the signal, the more negative the component. At test point three (TP3), the audio is removed by a low pass filter, R11 and C4, leaving only the DC component. Resistor R5 is used to shift the voltage at TP3 high enough to bias the base of transistor Q2 to the full gain position when no signal is present. Resistors R5 and R11 also forward bias diode D1 just enough to minimize "On Condition" threshold voltage.

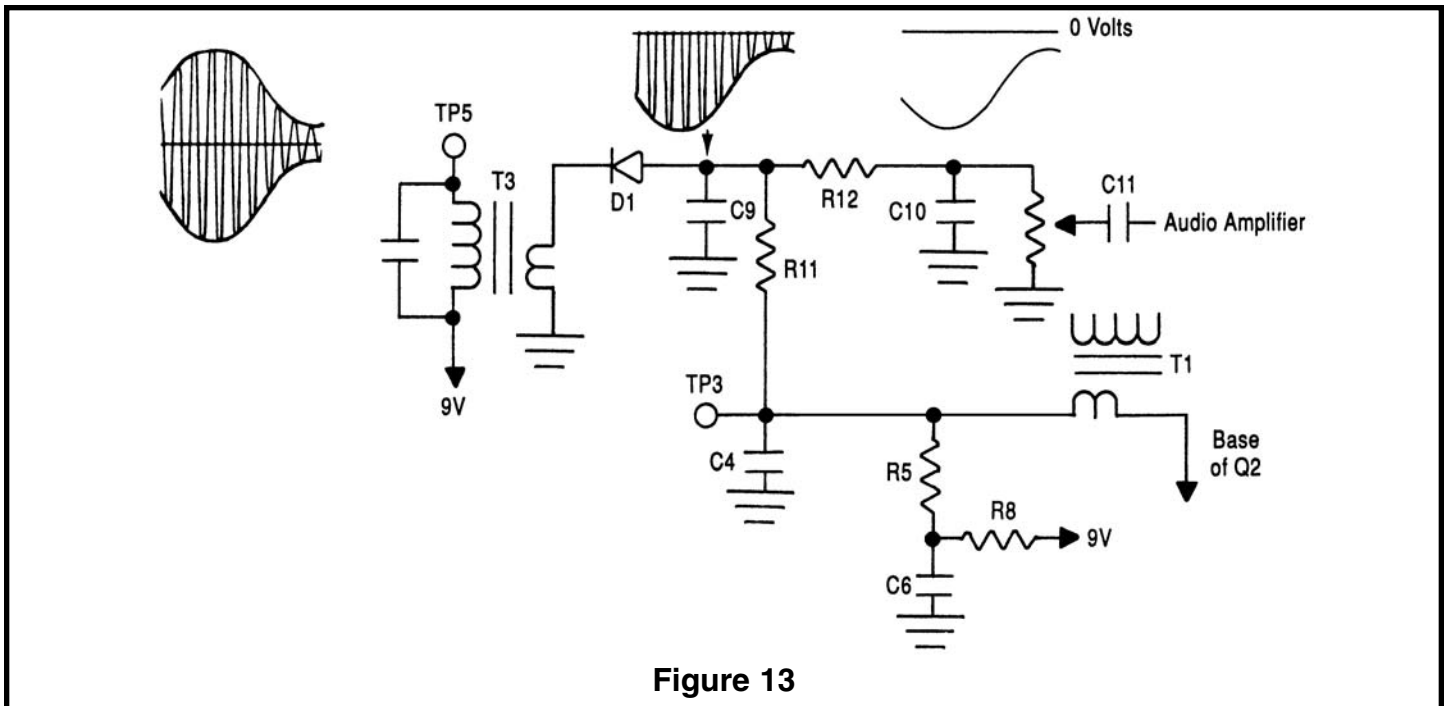
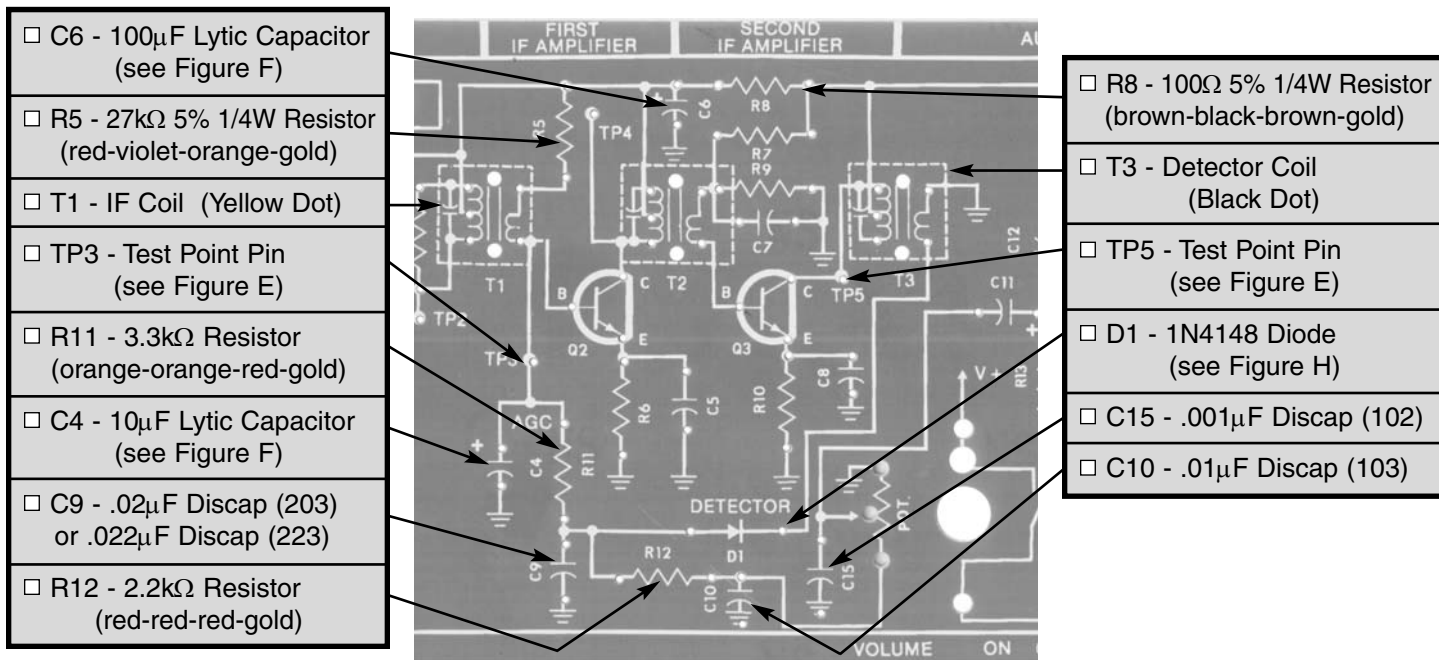


Figure 13



# ASSEMBLY INSTRUCTIONS - AM DETECTOR AND AGC STAGES



## STATIC MEASUREMENTS

### AGC ZERO SIGNAL BIAS

With the power turned OFF, connect the VOM to test point three (TP3) as shown in Figure 14. Check that the VOM is adjusted to read 9 volts DC and turn the power ON. The voltmeter should read approximately 1.5 volts DC. If your reading varies

more than .5 volts from this value, turn the power OFF and check the polarity of D1, and resistors R11 and R5. Also check that transformer T1 is properly installed.

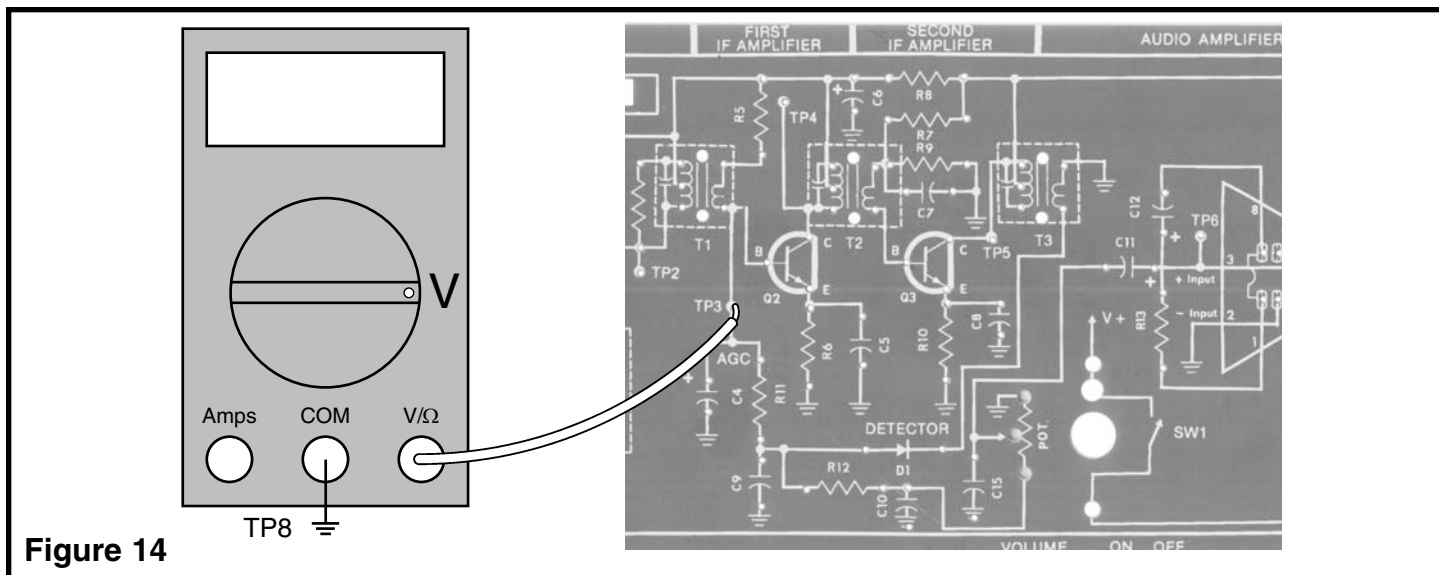


Figure 14

### T3 TEST

With the power turned OFF, connect the positive lead of the VOM to TP5 and the negative lead to any ground. Make sure that the VOM is set to read 9 volts DC and turn the power ON. The voltage on the

VOM should be the same as your battery voltage or power supply voltage. If not, turn OFF the power and check that T3 is properly installed.

If you do not have an RF generator, go to Section 3.

## DYNAMIC MEASUREMENTS

### DETECTOR AND ACG TEST

Turn the power OFF and connect the VOM and RF generator as shown in Figure 15.

Set the VOM to accurately read 2 volts DC and set the output of the RF generator for 455kHz, no modulation, and minimum amplitude. Turn the power

ON and slowly increase the amplitude of the 455kHz signal from the RF generator until the voltage at TP3 just starts to drop. This point is called the AGC threshold with no IF gain. Make a note of the amplitude setting on the RF generator here: \_\_\_\_\_ . Turn the power OFF.

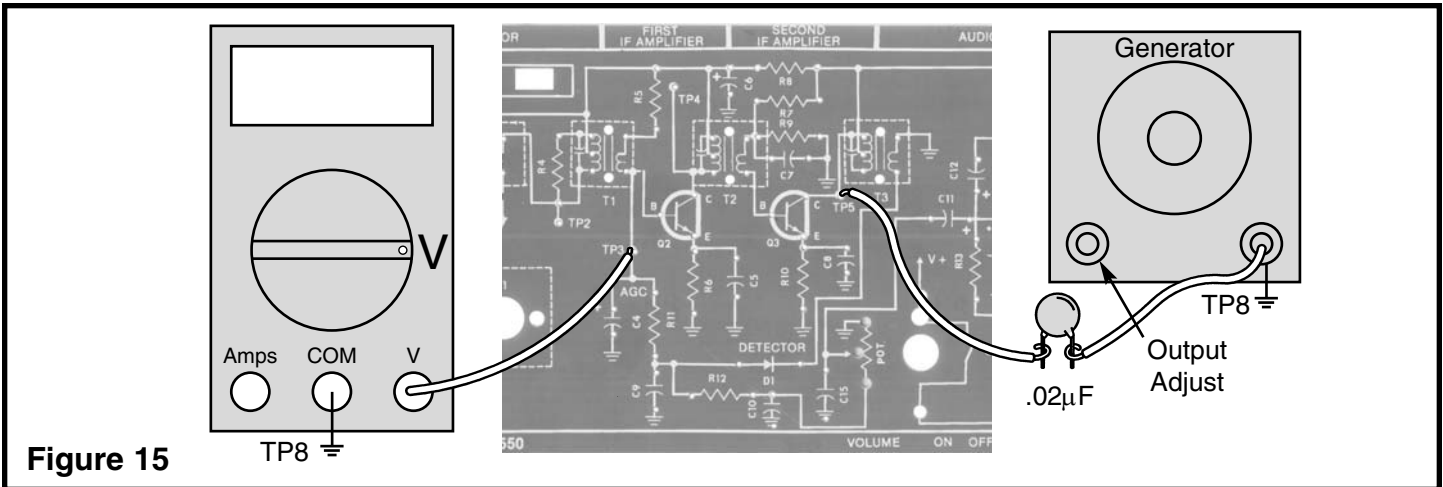


Figure 15

If your RF generator does not have amplitude modulation or you do not have an oscilloscope, go to Section 3.

### SYSTEM CHECK

Connect equipment as shown in Figure 16.

Set the RF generator at 455kHz, 1kHz at 80% modulation and minimum output. Turn the power ON and put the volume control at full clockwise position.

Slowly adjust the amplitude of the RF generator output until you hear the 1kHz on the speaker. If this test fails, turn the power OFF and check C11, R12, volume control, D1 and TP3.

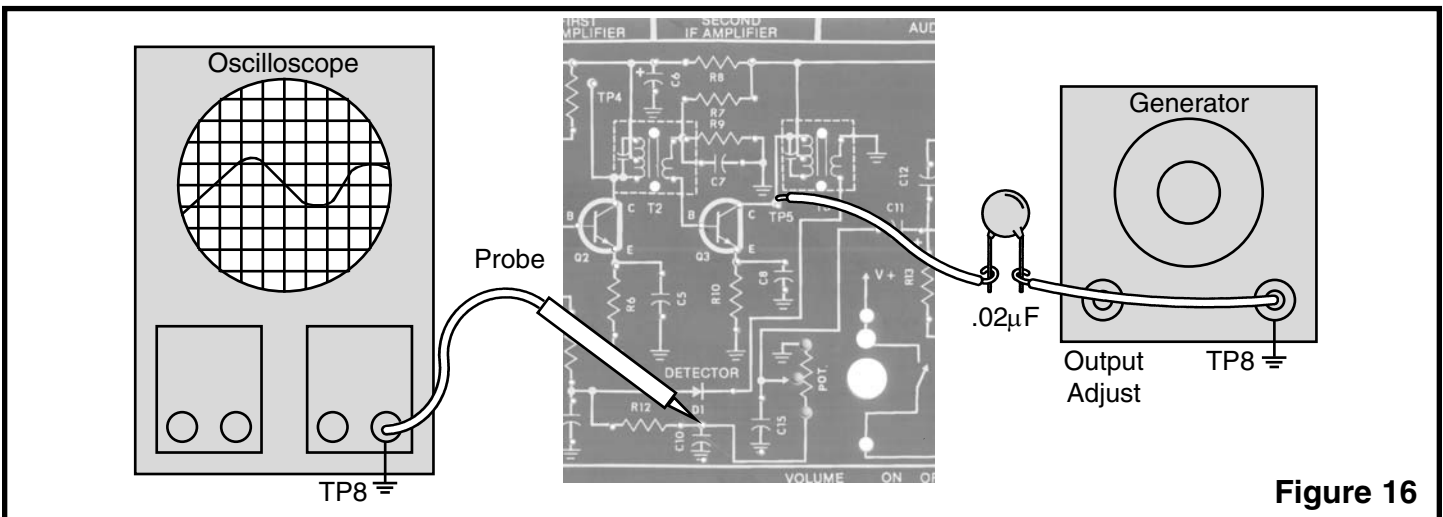


Figure 16

### DETECTOR BANDWIDTH TEST

Connect equipment as shown in Figure 16. Set the RF generator at 455kHz with 80% modulation at a modulation frequency of 1kHz. Set the oscilloscope to read .1 volts per division. Turn the power ON and put the volume control at minimum. Increase the amplitude of the RF generator until the signal on the oscilloscope is 4 divisions peak to peak. Check the signal to make sure it is free of all distortion. Leave

the frequency of the RF output at 455kHz, but increase the modulation frequency until the output drops to 0.28 Vpp. Record the modulation frequency on the RF generator here: \_\_\_\_\_

This frequency should be greater than 5kHz. Turn the power OFF.

# SECTION 3

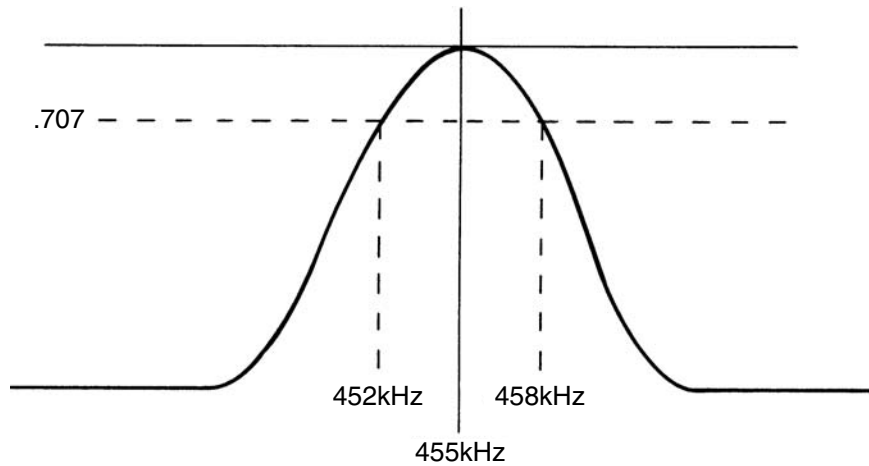
## SECOND IF AMPLIFIER

### THEORY OF OPERATION

The purpose of the SECOND IF AMPLIFIER is to increase the amplitude of the intermediate frequency (IF) and at the same time provide SELECTIVITY. Selectivity is the ability to “pick out” one radio station while rejecting all others. The second IF transformer (T3) acts as a bandpass filter with a 3dB bandwidth of approximately 6kHz. The amplitude versus frequency response of the second IF amplifier is shown in Figure 17.

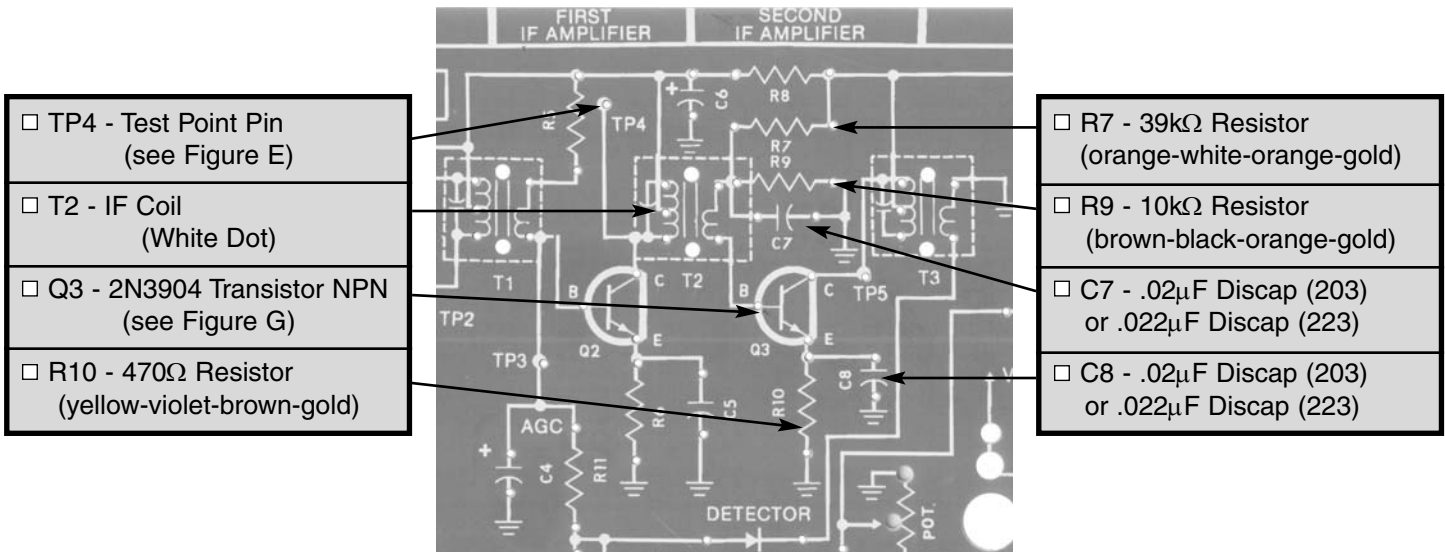
Both IF amplifiers are tuned to a frequency of 455kHz and only need to be aligned once when the radio is assembled. These amplifiers provide the majority of the gain and selectivity needed to separate the radio stations.

The gain at 455kHz in the second IF amplifier is fixed by the AC impedance of the primary side of transformer T3, and the DC current in Q3. The current in Q3 is set by resistors R7, R9 and R10. Both C7 and C8 bypass the 455kHz signal to ground, making Q3 a common emitter amplifier. The signal is coupled from the first IF amplifier to the second IF amplifier through transformer T2. The IF transformers not only supply coupling and selectivity, they also provide an impedance match between the collector of one stage and the base of the next stage. This match allows maximum power to transfer from one stage to the next.



**Figure 17**

## ASSEMBLY INSTRUCTIONS - SECOND IF AMPLIFIER



## STATIC MEASUREMENTS

### Q3 BIAS

With the power OFF, connect the negative lead of your VOM to any ground and the positive lead to the emitter of Q3 as shown in Figure 18. Set the VOM to read 9 volts DC and turn ON the power. The voltage at the

emitter of Q3 should be approximately 1 volt. If your reading is different by more than 0.5 volts, turn off the power and check your battery of power supply voltage. Also check components R7, R9, R10 and Q3.

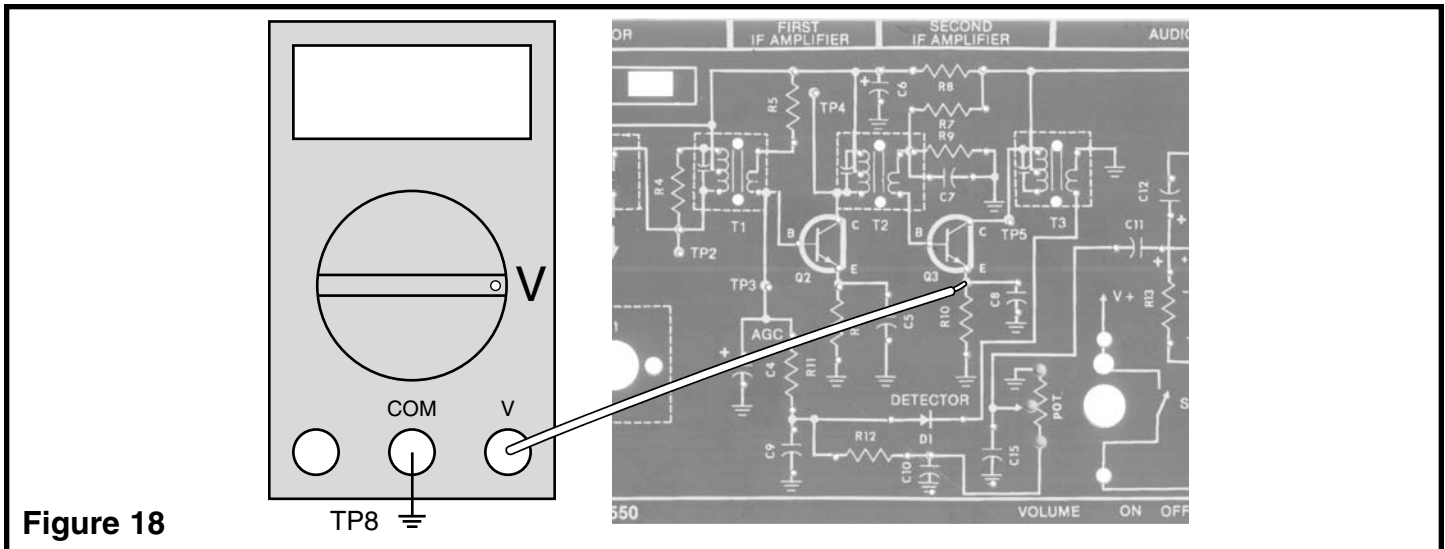


Figure 18

If you do not have an RF generator or oscilloscope, skip the following test and go to Section 4.

## DYNAMIC MEASUREMENTS

### AC GAIN

With the power turned OFF, connect the oscilloscope and the RF generator to the circuit as shown in Figure 19. Set the RF generator at a frequency of 455kHz, no modulation and minimum amplitude output. Set the oscilloscope vertical sensitivity at 1 volt/division. The scope probe must have an input capacitance of less than 50pF or it will detune transformer T3. Turn the power ON and slowly increase the amplitude of the RF signal until you have 4 volts peak to peak on the oscilloscope. Tune transformer T3 for a maximum

output while readjusting the RF generator amplitude to keep 4Vpp at the oscilloscope. After T3 is aligned, move the scope probe tip to the base of Q3 and record the peak to peak amplitude of the signal here:  $V_b = \text{_____} V_{pp}$ . Turn the power OFF. The AC gain of the second IF amplifier at 455kHz is equal to  $4/V_b$ , and should be greater than 100. If your gain is less than 100, check components C7, C8, R7, R9 and R10. Also, make sure that transistor Q3 is properly installed.

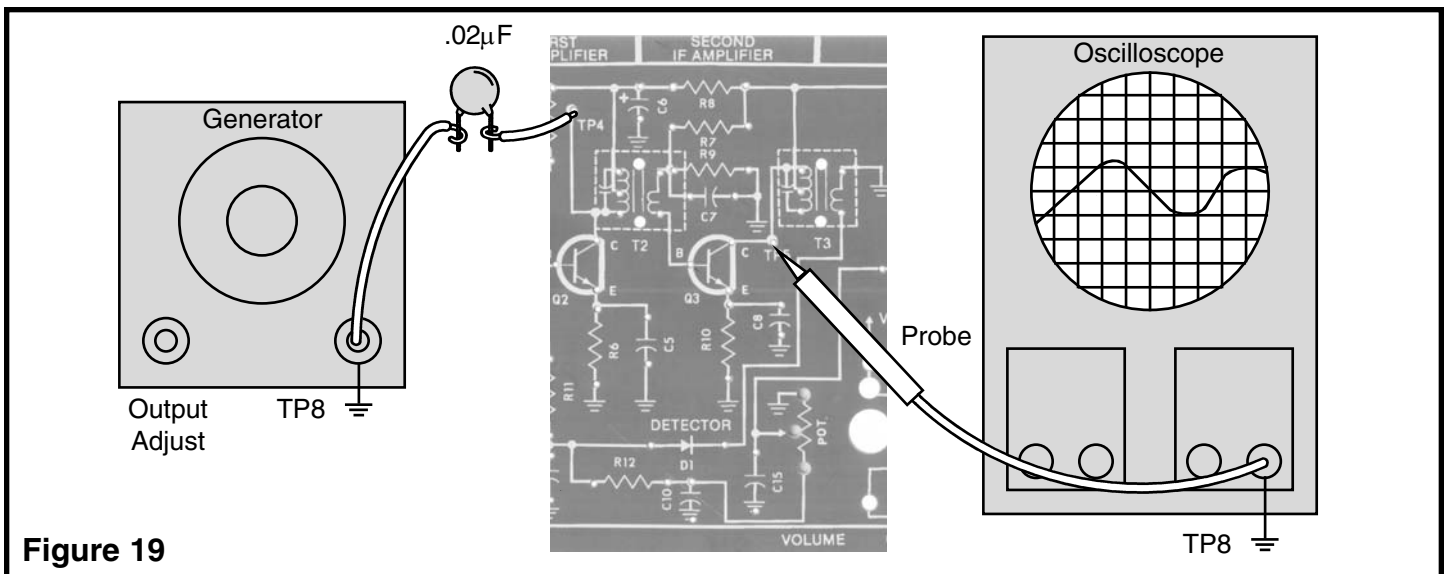


Figure 19

## BANDWIDTH TEST

With the power OFF, connect your equipment as shown in Figure 20. Turn the power ON and adjust the RF generator for .4Vpp at the cathode of D1. If necessary, realign transformer T3 for maximum output while adjusting the output of the RF generator to maintain .4Vpp. Slowly decrease the frequency of the RF generator until the signal drops to .707 of its peaked value or .28Vpp. Record the frequency of the RF generator here: FL=\_\_\_\_\_kHz.

Now increase the frequency of the RF generator past the peak to a point where the signal drops to .707 of its peak value. Record that frequency point here: FH=\_\_\_\_\_kHz. By subtracting the frequency of the lower 3dB corner from the frequency of the higher 3dB corner you get the BANDWIDTH of the second IF amplifier. Your results should be similar to the values shown in Figure 17.

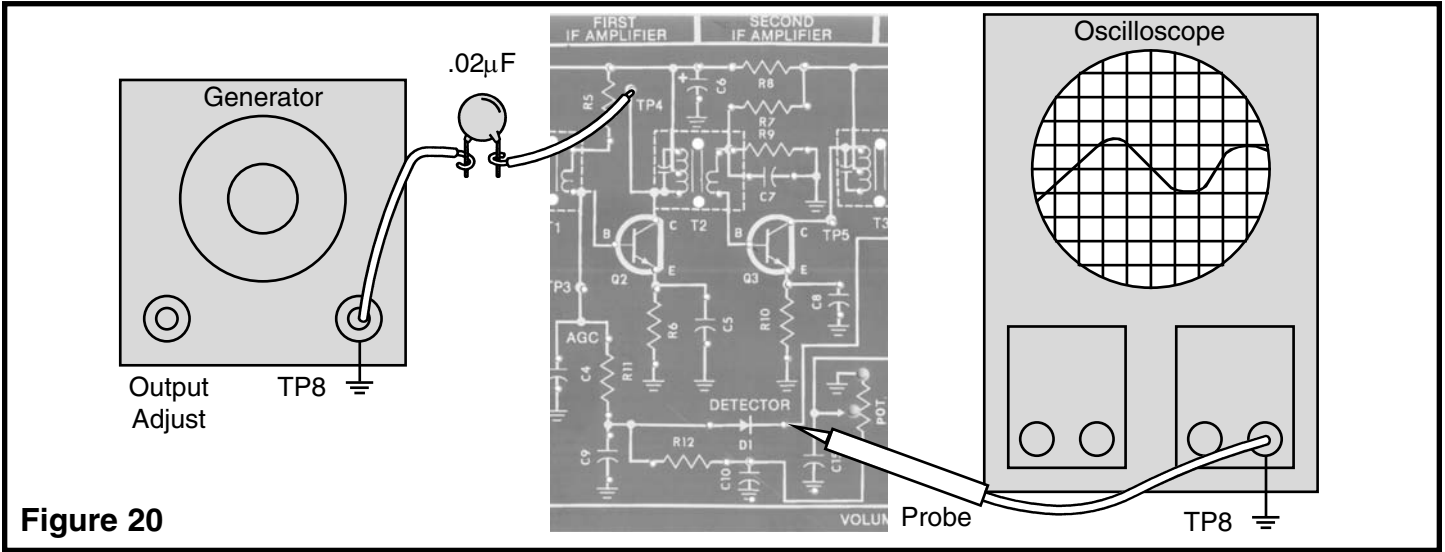


Figure 20

## SECTION 4

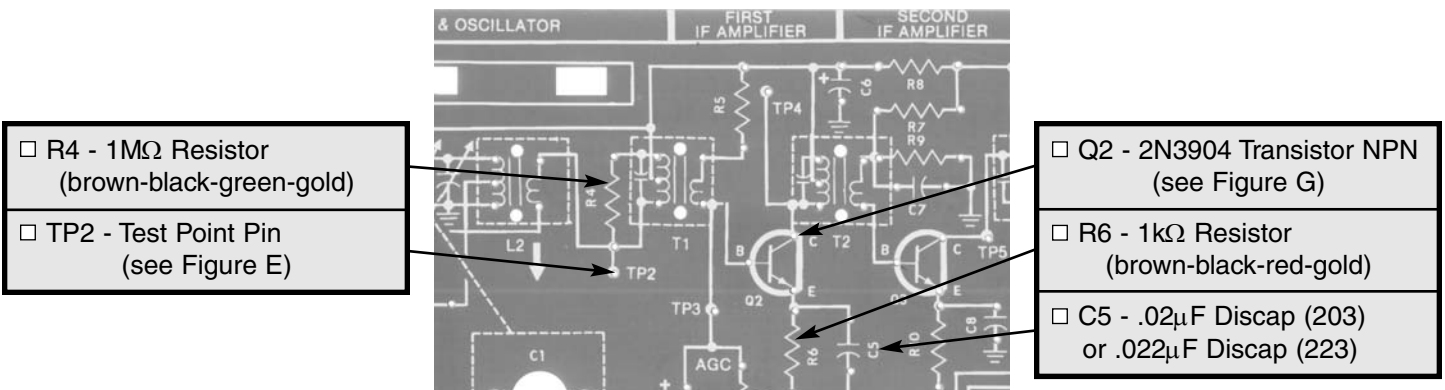
### FIRST IF AMPLIFIER

#### THEORY OF OPERATION

The operation of the first IF amplifier is the same as for the second IF amplifier with one important difference. The gain of the first IF amplifier decreases after the AGC threshold is passed to keep the audio output constant at the detector and prevent overload of the second IF amplifier. This is accomplished by making the voltage on the base of transistor Q2, lower as the signal strength increases. Since the voltage from base to emitter is fairly constant, the drop in voltage at the base produces a similar drop in voltage at the emitter of Q2. This drop

lowers the voltage across R6 and thus reduces the DC current through R6. Since all of the DC current from the emitter of Q2 must go through R6, the DC current in Q2 is therefore lowered. When the DC current in a transistor is lowered, its effective emitter resistance increases. The AC gain of transistor Q2 is equal to the AC collector load of Q2 divided by its effective emitter resistance. Raising the value of the effective emitter resistance thus lowers the AC gain of Q2.

### ASSEMBLY INSTRUCTIONS - FIRST IF AMPLIFIER



## STATIC MEASUREMENTS

### Q2 BASE BIAS

With the power turned OFF, reconnect your VOM to test point 3 (TP3) as shown in Figure 14. Set the VOM to read 2 volts DC accurately and turn the power ON. The

voltage should be approximately 1.5 volts. If your circuit fails this test, turn the power OFF and check Q2 and R6.

### Q2 CURRENT

With the power turned OFF, connect the positive lead of the VOM to the emitter of Q2. Connect the negative lead of the VOM to any DC ground and turn the power ON. The voltage should be approximately

0.8 volts. Since the current in Q2 is equal to the current in R6,  $I(Q2)=0.8/R6$  or approximately 0.8 milliamps.

**If you do not have an RF generator or oscilloscope, skip the following test and go to Section 5.**

## DYNAMIC MEASUREMENTS

### AC GAIN

With the power turned OFF, connect the RF generator and the oscilloscope to your circuit as shown in Figure 21. Using a clip lead, short TP5 to R8 as shown in Figure 21. This short prevents the AGC from lowering the gain of the first IF amplifier. Set the RF generator to 455kHz, no modulation, and minimum amplitude output. Set the oscilloscope for a vertical sensitivity of 1 volt/division and turn the power ON. Increase the amplitude output from the RF generator until approximately 4Vpp registers on the oscilloscope. Tune the IF transformer (T2) to maximize the 455kHz at TP4. After tuning T2, adjust

the RF generator amplitude in order to keep 4Vpp at TP4. Now move the oscilloscope probe to the base of Q2 and record the peak to peak level of the 455kHz signal here:

$$V_b = \text{_____} V_{pp}$$

The AC gain of the first IF amplifier is equal to  $4/V_b$ . The AC gain of this amplifier should be greater than 100. **DO NOT TURN THE POWER OFF. GO TO THE NEXT TEST.**

### AGC ACTION

Move the oscilloscope probe back to TP4 and adjust the RF generator for 4Vpp if necessary. Remove the

clip lead shorting TP5 to R8. The AGC should reduce the signal level at TP4 to approximately 0.8 volts.

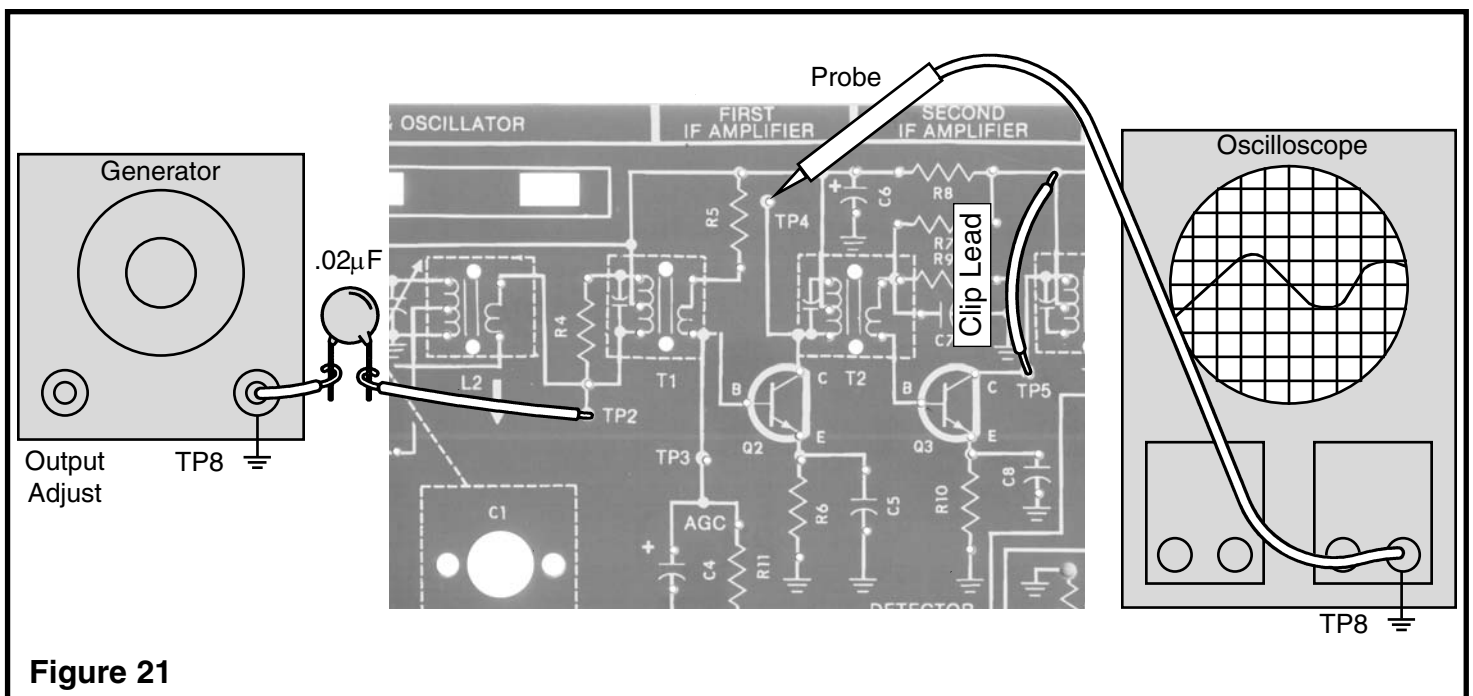


Figure 21

## SECTION 5

### MIXER AND OSCILLATOR

#### THEORY OF OPERATION

In a superheterodyne type receiver the radio wave at the antenna is amplified and then mixed with the local oscillator to produce the intermediate frequency (IF). Transistor Q1 not only amplifies the RF signal but also simultaneously oscillates at a frequency 455kHz above the desired radio station frequency. Positive feedback from the collector to the emitter of Q1 is provided by coil L2 and capacitor C3. During the heterodyne process, the following four frequencies are present at the collector of Q1.

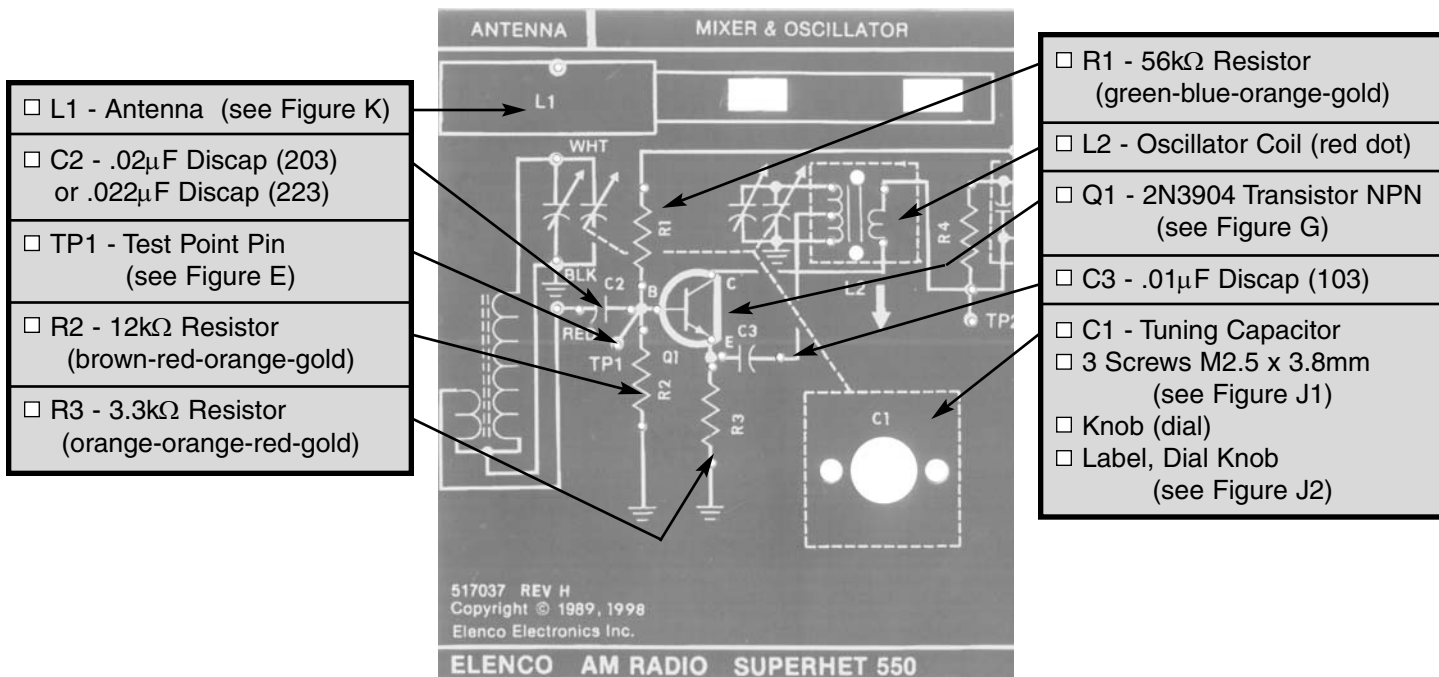
1. The local oscillator frequency, LO.
2. The RF carrier or radio station frequency.
3. The sum of these two frequencies, LO + RF.
4. The difference of these two frequencies, LO - RF.

The “difference frequency” is used as the intermediate frequency in AM radios. The collector of Q1 also contains an IF transformer (T1) tuned only to the difference frequency. This transformer rejects all frequencies except those near 455kHz. T1 also couples the 455kHz signal to the base of Q2 to be processed by the IF amplifiers.

The antenna and the oscillator coils are the only two resonant circuits that change when the radio is tuned for different stations. Since a radio station may exist 455kHz above the oscillator frequency, it is important that the antenna rejects this station and selects only the station 455kHz below the oscillator frequency. The frequency of the undesired station 455kHz above the oscillator is called the image frequency. If the selectivity of the antenna (Q factor) is high, the image will be reduced sufficiently.

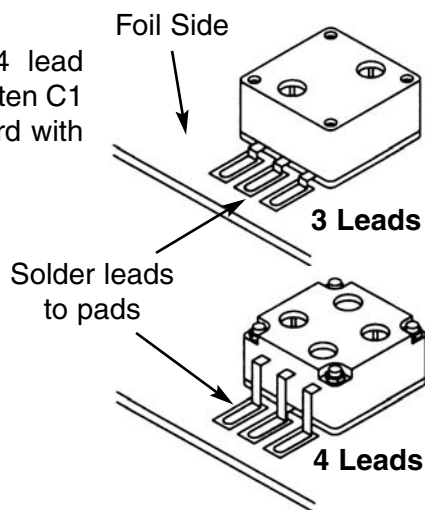
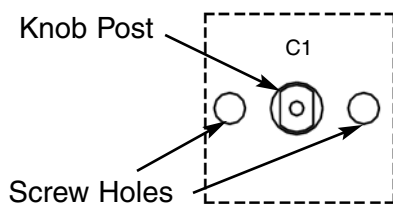
The oscillator circuit must also change when the radio is tuned in order to remain 455kHz above the tuning of the desired radio station. The degree of accuracy in keeping the oscillator frequency exactly 455kHz above the tuning of the antenna is called tracking accuracy.

# ASSEMBLY INSTRUCTIONS - ANTENNA, MIXER AND OSCILLATOR



## Tuning Capacitor Figure J1

Your kit may contain a 3 lead or a 4 lead capacitor. Bend the leads as shown. Fasten C1 into place on the top side of the PC board with two M2.5 x 3.8mm" screws.

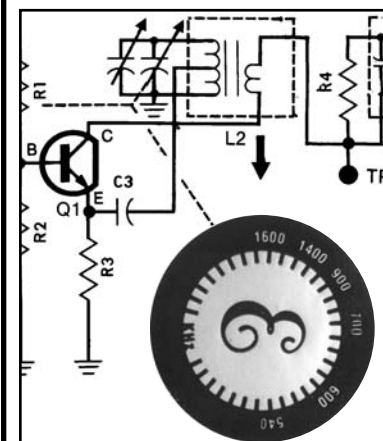


Solder the tuning capacitor. Be very careful, excessive heat can damage the capacitor's dielectric insulation.

## Figure J2

Fasten the knob (dial) into place with a M2.5 x 3.8mm screw to the C1 post.

Turn the dial fully clockwise. Remove the protective backing from the label and align the 1600 with the arrow on the PC board.

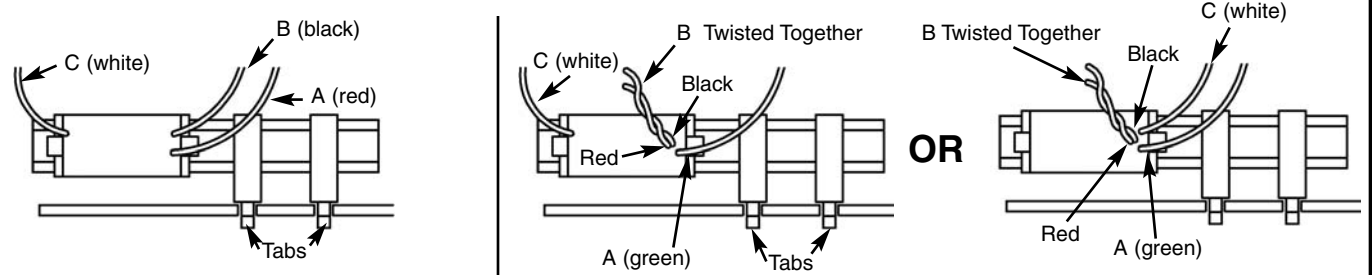
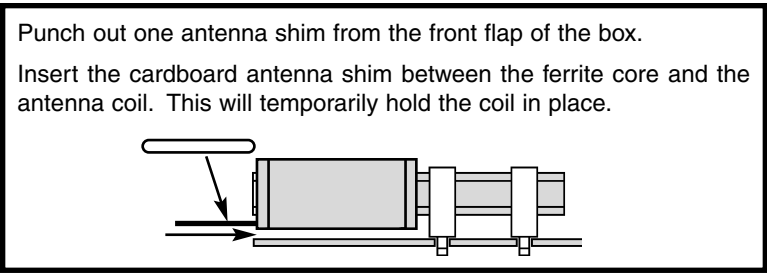




**IMPORTANT:** Before installing the antenna coil, determine if you have a 3 wire coil or a 4 wire coil. Assemble it to the PC board as shown below. Mount the antenna assembly to the PC board.

- Put the tab of the first holder into the right hole and twist the tab 90°.
- Put the tab of the second holder into the left hole and twist the tab 90°.
- Slide the ferrite core through the holders.
- Slide the antenna coil through the ferrite core.

**Note:** If the end of a wire from the antenna should break off, strip the insulation off the end with a hot soldering iron. Lay the wire down on a hard surface and stroke the wire with your iron. The insulation should come off very easily. **CAUTION:** The soldering iron will burn the hard surface that you are working on.



**3 Wire Type Antenna**

Solder the 3 colored wires to the PC board.

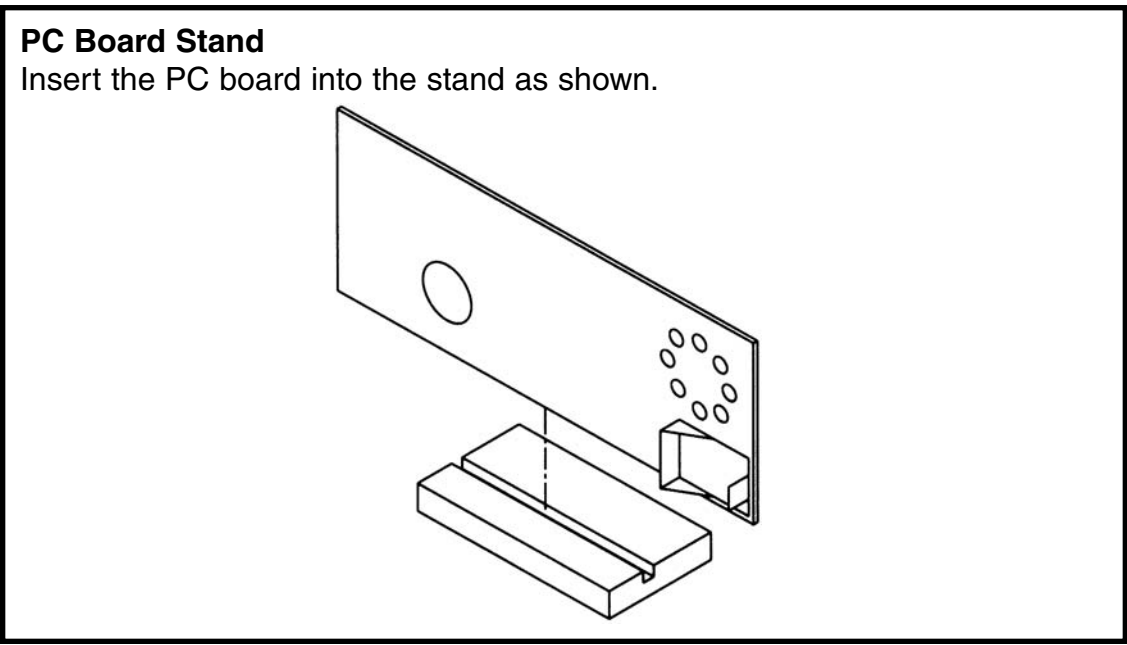
- Wire A (red) to the hole marked "RED".
- Wire B (black) to the hole marked "BLK".
- Wire C (white) to the hole marked "WHT".

**4 Wire Type Antenna**

Solder the 4 colored wires to the PC board.

- Wire A (green) to the hole marked "RED".
- Wire B (red and black twisted together) to the hole marked "BLK".
- Wire C (white) to the hole marked "WHT".

**Figure K**



## STATIC MEASUREMENTS

### Q1 BIAS

With the power turned OFF, connect the VOM to your circuit as shown in Figure 22. Connect a clip lead from test point two (TP2) to the collector of Q1. This short prevents Q1 from oscillating. Set the VOM to read 2 volts DC accurately and turn the power ON. The DC

voltage at TP1 should be 1.6 volts. If the voltage in your circuit differs by more than 0.5 volts, leave the power ON and check the battery voltage. If the battery voltage is greater than 8.5 volts, turn the power OFF and check components R1, R2, R3 and Q1.

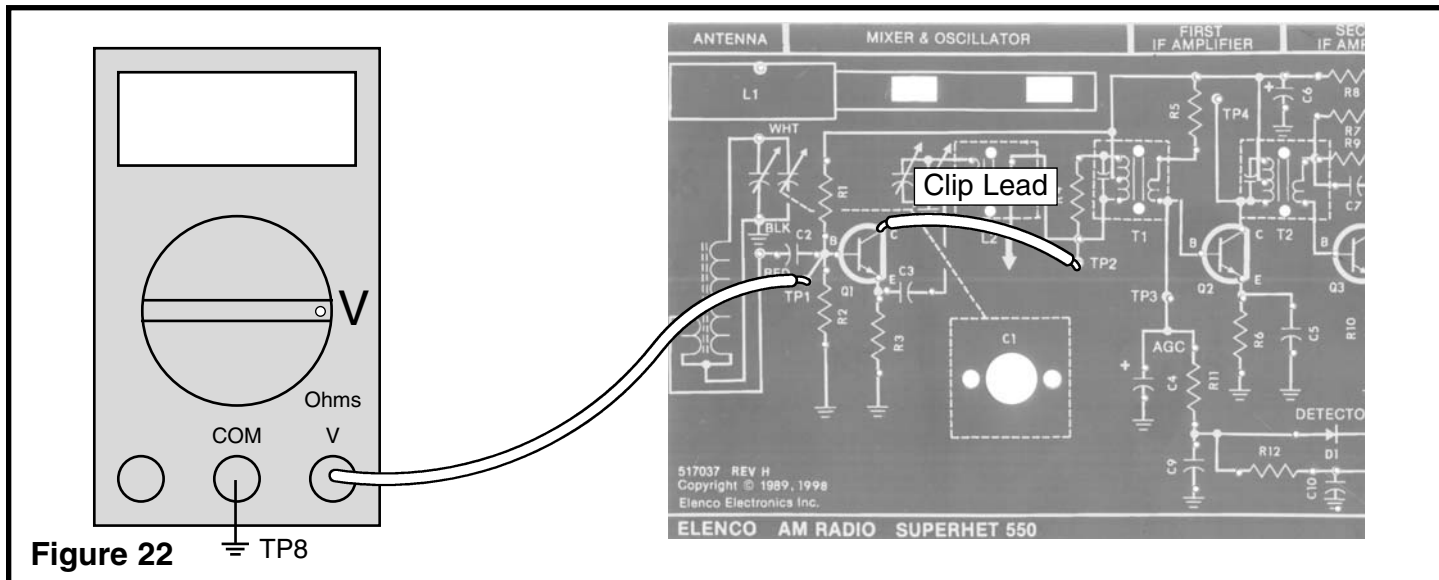


Figure 22

If you do not have an oscilloscope, go to the Final Alignments With No Test Equipment Section.

## DYNAMIC MEASUREMENTS

### OSCILLATOR CIRCUIT

With the power turned OFF, connect the oscilloscope to the circuit as shown in Figure 23.

Set the oscilloscope for a vertical sensitivity of 1 volt/division and turn the power ON. The oscilloscope should display a low voltage sine wave. The

frequency of the sine wave should change when capacitor C1 is turned. If your circuit fails this test, turn the power OFF and check components Q1, C1, C2, C3, L1 and L2.

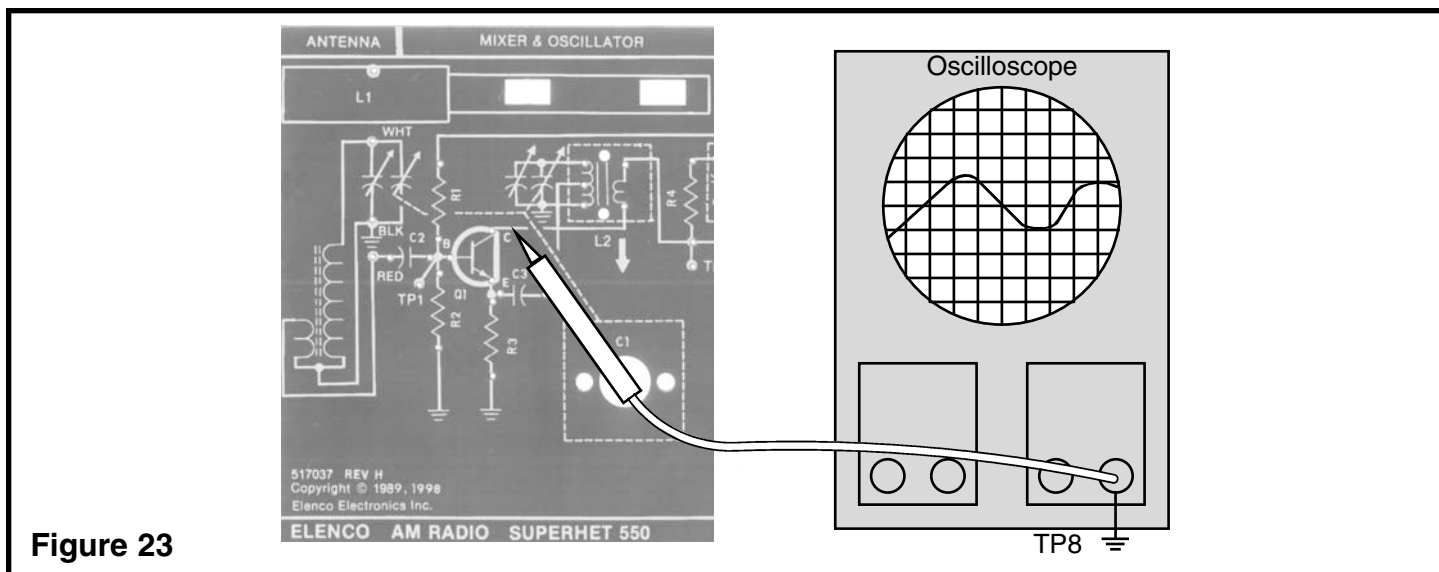


Figure 23

If you do not have an RF generator, go to the Final Alignments with No Test Equipment Section.

# FINAL ALIGNMENTS

## IF BANDWIDTH

With the power turned OFF, connect the RF generator and the oscilloscope to your circuit as shown in Figure 24. Short TP2 to the collector of Q1 with a clip lead to “kill” the local oscillator. Set the RF generator at a frequency of 455kHz, modulation of 400Hz 80%, minimum amplitude output. Set the oscilloscope to read 0.1Vpp and turn the power ON. Increase the amplitude of the RF signal until the oscilloscope registers 0.5Vpp. Align transformers T3, T2 and T1 for the maximum AC reading on the oscilloscope. Decrease the amplitude of the signal from the RF generator to restore 0.5Vpp on the oscilloscope. Repeat the last two steps until no change in the peak at the oscilloscope is noticed.

After IF alignment, lower the frequency from the RF generator until the reading on the VOM drops to 0.707 of its peaked value. Record the frequency of this lower 3dB corner here:

$$F_l = \text{_____ kHz.}$$

Increase the RF generator frequency past the peak to the upper 3dB corner and record that frequency here:

$$F_h = \text{_____ kHz.}$$

The bandwidth of the IF amplifiers is  $BW = F_h - F_l$ . IF bandwidth should be between 1 to 2kHz. This bandwidth will widen as the AGC is approached.

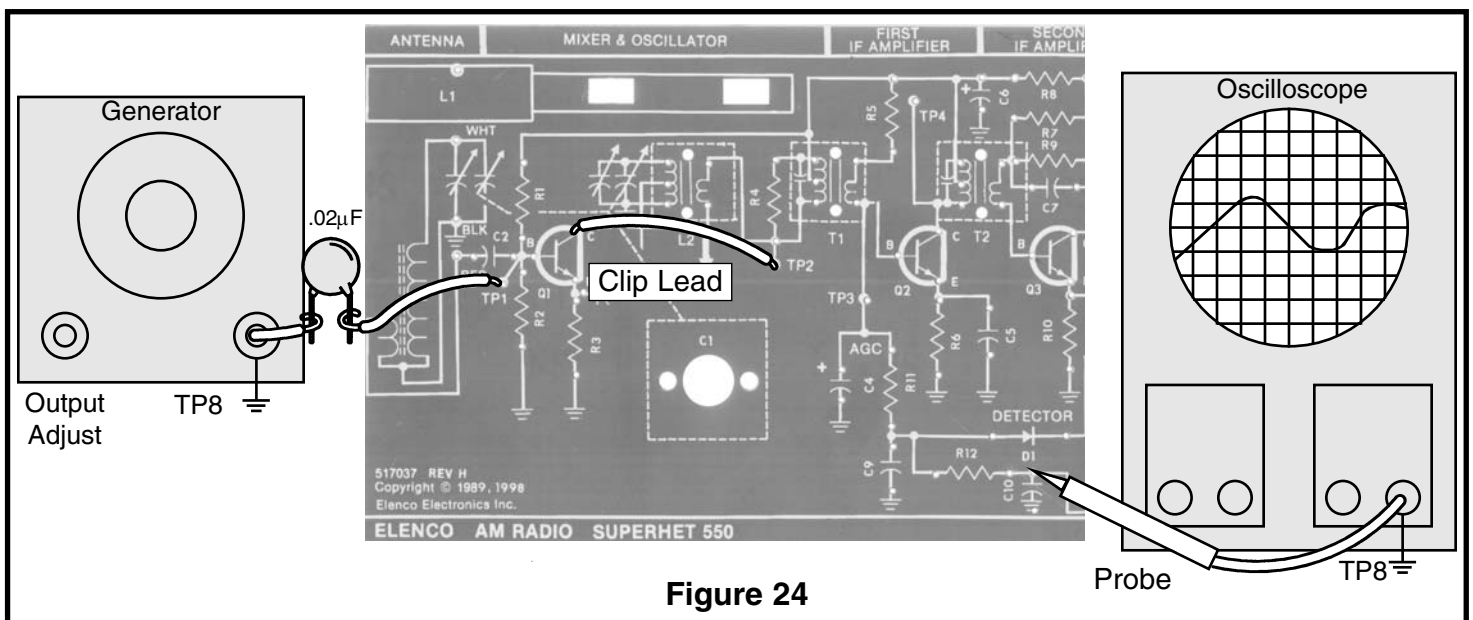


Figure 24

## SETTING OSCILLATOR RANGE

With the power turned OFF, connect the equipment to the circuit as shown in Figure 24. DO NOT connect the clip lead from TP2 to Q1. Set the RF generator at 540kHz, 400Hz 80% modulation, and a low level of output. Turn the tuning capacitor fully counter-clockwise. Turn the power ON and a 400Hz tone should be heard coming from the speaker. Tune the oscillator coil (L2) for a peak on the oscilloscope.

Adjust the RF generator output during this process to maintain a peak at 0.5Vpp or less. After peaking L2, set the RF generator frequency to 1600kHz and turn the tuning capacitor (C1) fully clockwise. A 400Hz tone should be heard coming from the speaker. Tune the oscillator trimmer capacitor on the back of C1 for a peak on the oscilloscope (see Figure 25).

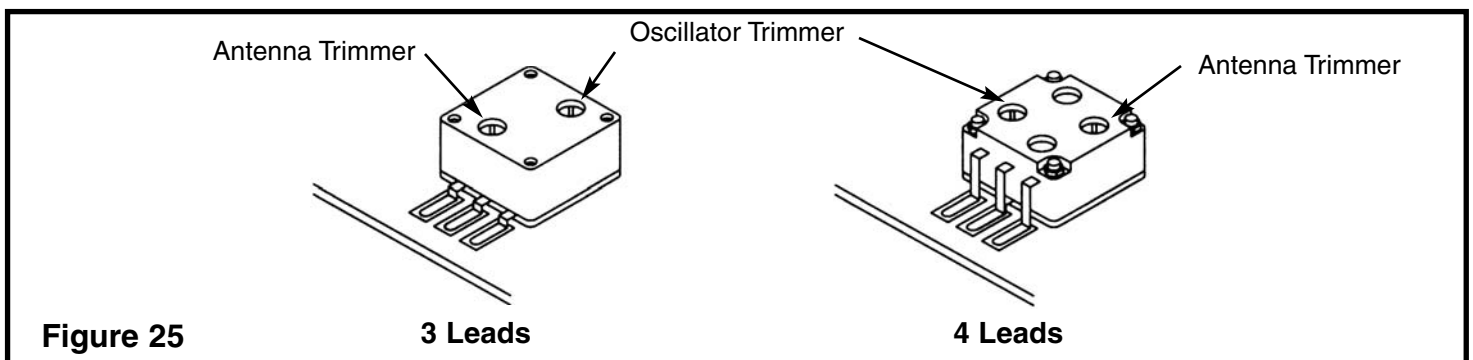


Figure 25

3 Leads

4 Leads

After peaking the oscillator trimmer capacitor, return the RF generator to 540kHz, and capacitor C1 to the fully counter-clockwise position and readjust L2. Repeat the last few steps until both settings of the oscillator are correct. This process sets the oscillator range at 995kHz to 2055kHz. If a frequency counter

is available, you may verify this alignment by measuring the frequency at the emitter of Q1 for both ends of the tuning capacitor (C1). Be careful not to mistune the oscillator during this measurement. A coupling capacitor of 82 picofarads or less to the frequency counter is recommended.

### ANTENNA ALIGNMENT

With the power turned OFF, connect test equipment to your circuit as shown in Figure 26. Set the RF generator at 600kHz, 400Hz 80% modulation, moderate signal strength. Set the oscilloscope to read .5Vpp and turn the power ON. Turn C1 fully counter-clockwise, then slowly turn C1 clockwise until a 400Hz tone can be heard coming from the speaker. Slowly slide the antenna coil back and forth on the ferrite rod to obtain a peak on the oscilloscope. For maximum signal, your location of the antenna coil may have to be on the end of the ferrite rod (as shown in Figure 27). Change the

frequency of the RF generator to 1400kHz and adjust C1 until a 400Hz tone can be heard coming from the speaker. Carefully peak the reading on the oscilloscope by adjusting the frequency of the RF generator. Now tune the antenna coil to this frequency by adjusting the antenna trimmer on the back of C1 (see Figure 25). This process should be repeated until both settings of the antenna track the oscillator tuning. Once the antenna is properly aligned, carefully apply candle wax or glue to the antenna coil and ferrite rod (as shown in Figure 27).

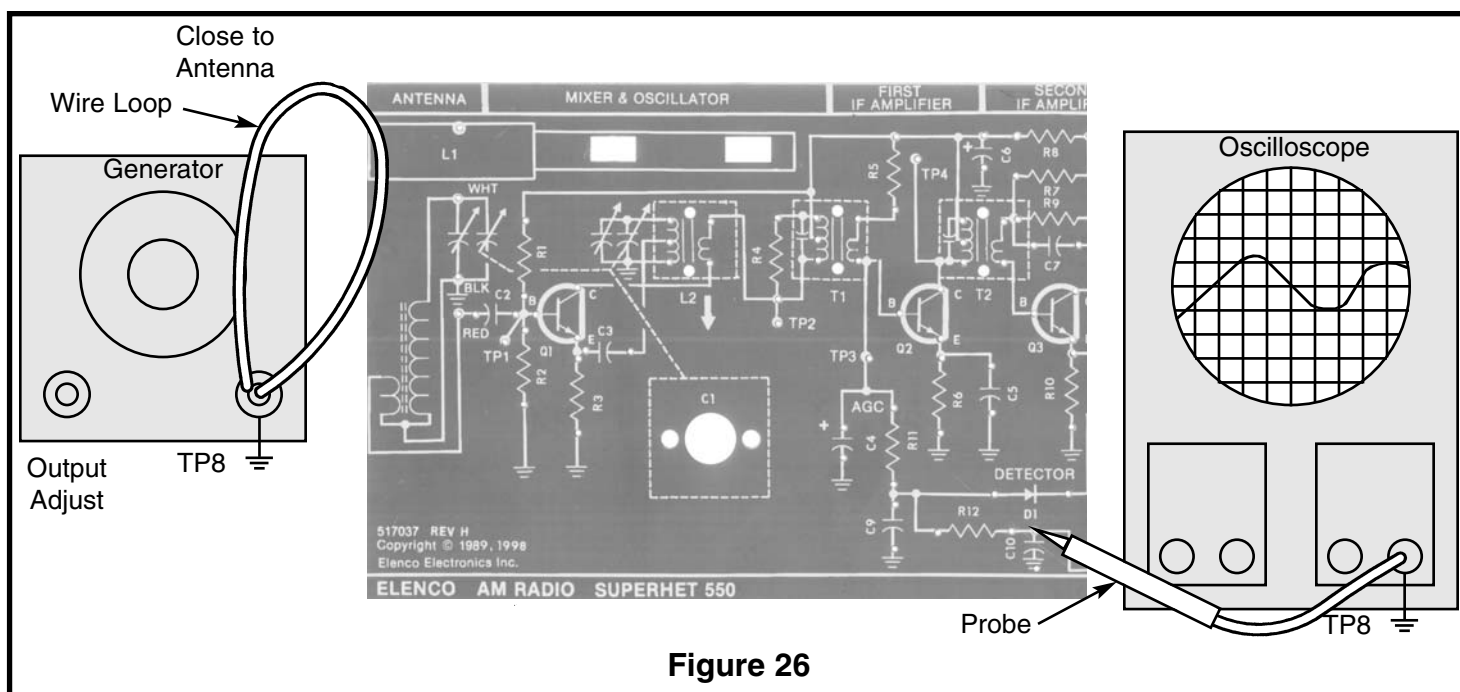


Figure 26

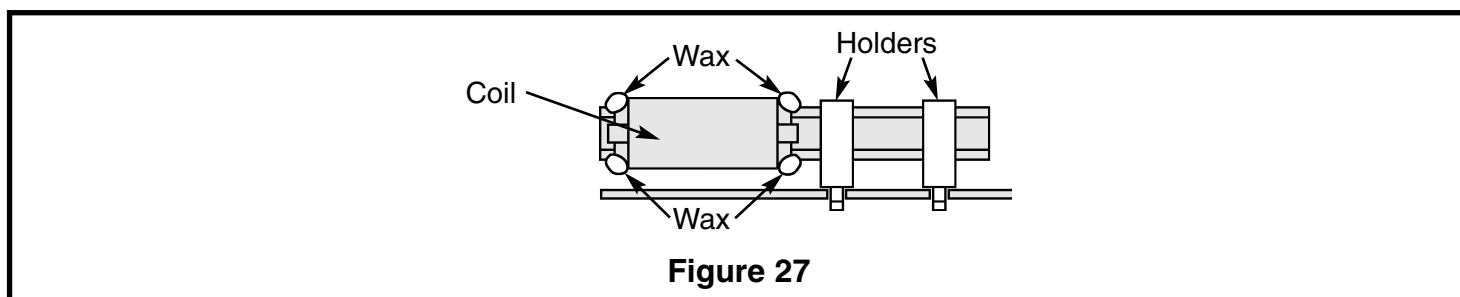


Figure 27

---

## FINAL ALIGNMENT WITH NO TEST EQUIPMENT

It is best to use an earphone for this alignment procedure.

With an alignment tool or screwdriver, turn coils L2, T1, T2 and T3 fully counter-clockwise until they stop. **DO NOT FORCE THE COILS ANY FURTHER.** Turn each coil in about 1 1/4 to 1 1/2 turns. Set the antenna coil about 1/8" from the end of its ferrite rod. Refer to Figure K on page 24.

Turn the power ON and adjust the volume to a comfortable level. Tune the dial until a weak station is heard. If no stations are present, carefully slide the antenna back and forth on its ferrite rod and retune the dial if necessary. With an alignment tool or screwdriver, adjust T1 until the station is at its loudest. Reduce the volume control if necessary. Adjust T2 until the station is at its loudest and reduce the volume control if necessary. Adjust T3 until the station is at its loudest and reduce the volume if necessary. Retune the radio for another weak station and repeat this procedure until there is no more improvement noticed on the weakest possible station. This procedure peaked the IF amplifiers to their maximum gain.

Tune the radio until a known station around 600kHz is found. It may be necessary to listen to the station until their broadcast frequency is announced. If no stations are present at the low side of the AM band,

adjust L2 until a station is heard. Once a station is found and its broadcast frequency is known, rotate the dial until the white pointer is aligned with that station's frequency marking on the dial. Adjust L2 until the station is heard. Tune the radio until a station around 1400kHz is heard. It may be necessary to listen to the station until their broadcast frequency is announced. If no stations are present at the high end of the AM band, adjust the oscillator trimmer on the back of the gang. Once a station is found and its broadcast frequency is known, rotate the dial until the white pointer is aligned with that station's frequency marking on the dial. Adjust the oscillator trimmer located on the back of the gang until a station is heard. Repeat these steps until the oscillator alignment is optimized. This procedure set the oscillator range at 995kHz to 2055kHz.

Tune the radio for a station around 600kHz. Carefully slide the antenna coil back and forth until the station is at its loudest. Tune the radio for a station around 1400kHz. Adjust the antenna trimmer located on the back of the gang (as shown in Figure 25) until the station is at its loudest. Repeat these steps until the antenna alignment is optimized. This procedure set the antenna to "track" the oscillator. Once the antenna is properly aligned, carefully apply candle wax or glue the antenna coil to the ferrite rod to prevent it from moving (as shown in Figure 27).

---

### DC Voltages

The voltage readings below should be used in troubleshooting the AM radio.

Q1	B	1.5V	U1	1	- 1.3V
	E	1.0V		2	- 0
	C	8.9V		3	- 0
				4	- 0
Q2	B	1.4V		5	- 4.5V
	E	0.7V		6	- 9V
	C	8.9V		7	- 4.6V
				8	- 1.3V
Q3	B	1.7V			
	E	1.0V			
	C	9.0V			

### Test Conditions

1. Volume control set to minimum.
2. Connect a jumper wire between capacitor C2 (side that goes to the lead of the antenna coil L1) to negative battery.
3. Battery voltage - 9.0V
4. All voltages are referenced to circuit common.
5. Voltage reading can vary  $\pm 10\%$ .

# AM-550 RADIO BAFFLE

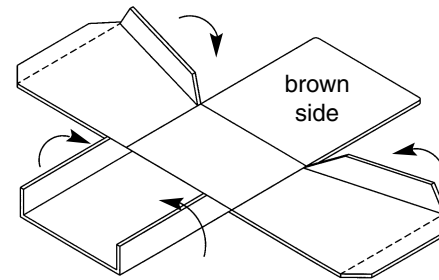
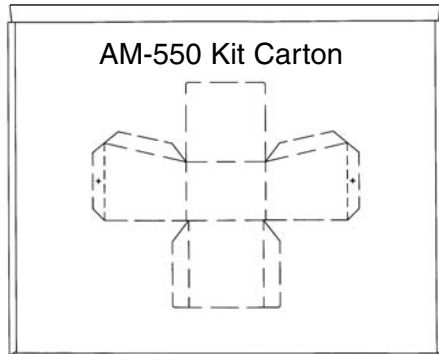
**NOTICE: Keep the box the kit came in.** After you have completed the radio and it operates satisfactorily, you may want to install a baffle to improve the sound.

The final step in the radio kit will be to assemble and attach a baffle to the speaker. You will need to remove the baffle located in the bottom of the box. If it does not want to come out easily, use a knife to cut the holding tabs.

When a speaker is not enclosed, sound waves can travel in all directions. As a speaker moves outward, it creates positive pressure on the air in front of it and negative pressure on the rear. At low frequencies, out of phase front and rear waves mix causing partial or total cancellation of the sound wave. The end result is a speaker less efficient and distorted.

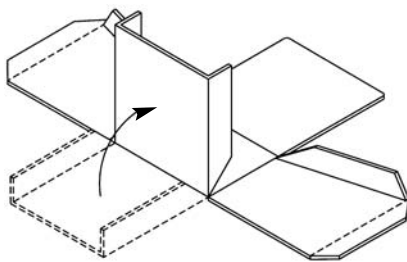
To eliminate the low frequency cancellation, a speaker is placed inside an enclosure. Now the front sound waves are prevented from traveling to the back. The speaker will now compress and decompress air inside, increasing its resonant frequency and Q relative to the free air values. This type of effectively air-tight box is called an Acoustic Suspension.

- Screw 2-56 x 5/16"
- Nut 2-56
- Baffle

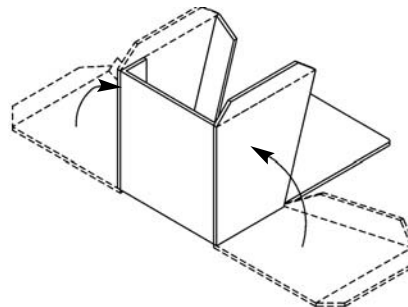


2. Bend the four flaps upward as shown.

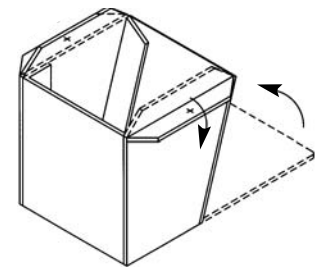
1. Start at one edge and carefully remove the baffle from the bottom of the kit box.



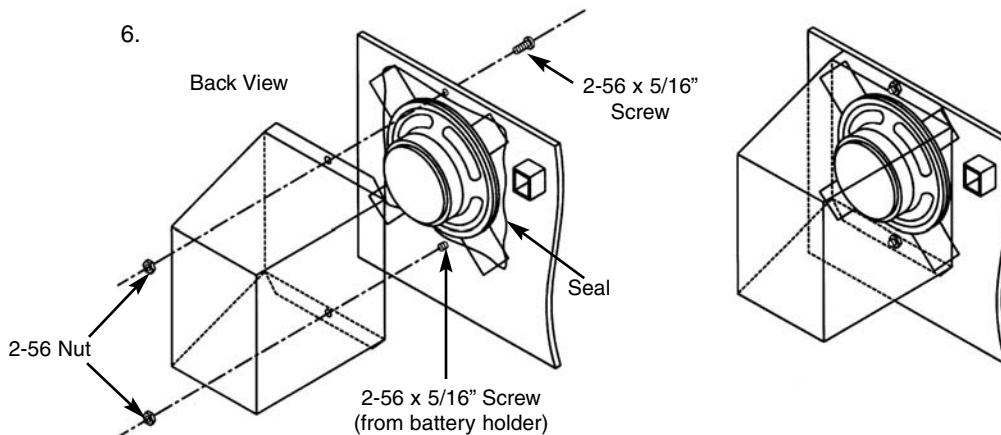
3. Bend the top side upward as shown.



4. Bend the two sides upward. Attach the three sides using scotch tape or glue (Elmer's, Duco Cement, or other).



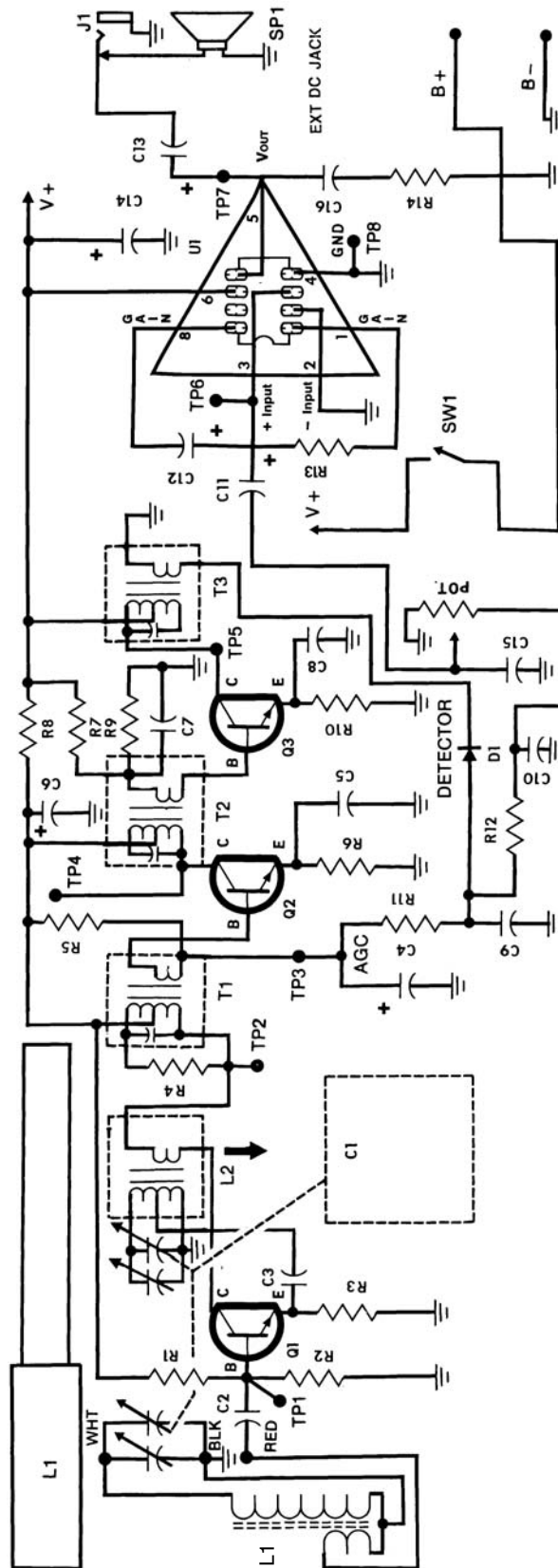
5. Bend the bottom side upward and attach it to the other sides using scotch tape or glue. Bend the two mounting flaps as shown.



Remove the nut from the top 2-56 x 5/16" screw. Insert the baffle as shown in Step 6. Insert a 2-56 x 5/16" screw and fasten down the baffle with two 2-56 nuts as shown in Step 6.

**Optional:** To make an air tight seal, place a bead of seal between the PC board and the baffle.

# SCHEMATIC DIAGRAM



REV-A

**Elenco® Electronics, Inc.**

150 Carpenter Avenue

Wheeling, IL 60090

(847) 541-3800

Web site: [www.elenco.com](http://www.elenco.com)

e-mail: [elenco@elenco.com](mailto:elenco@elenco.com)