

■ Contents

1. BEFORE STARTING	57
2. PACKAGE CONTENTS	57
3. GENERAL CAUTIONS	58
4. CAUTIONS ON INSTALLATION	58
5. INSTALLING THE MAIN UNIT	59
6. REMOVING THE MAIN UNIT	61
7. CAUTIONS ON WIRING	61
8. WIRE CONNECTION	62
9. SAMPLE SYSTEMS	65

1. BEFORE STARTING

1. This set is exclusively for use in cars with a negative ground 12 V power supply.
2. Read these instructions carefully.
3. Be sure to disconnect the battery “⊖” terminal before starting. This is to prevent short circuits during installation. (Figure 1)

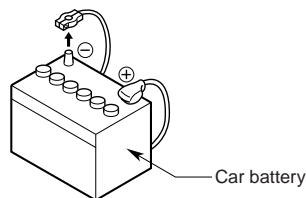

Figure 1

2. PACKAGE CONTENTS

- | | |
|--|---|
| <ul style="list-style-type: none"> ① Main unit ② Tuner Amp unit ③ Manuals <ul style="list-style-type: none"> Owner's manual & Installation manual Warranty card ④ Power supply lead (For the tuner amp unit) ⑤ Connection cord (Main unit ↔ Tuner amp unit) ⑥ Antenna extension cord ⑦ Bag for accessories of the main unit (No. 1) <ul style="list-style-type: none"> Flat head screw (M5 × 8) 4 Sems hexagonal bolt (M5 × 8) 5 Electro tap Machine screw (M4 × 3) 4 | <ul style="list-style-type: none"> ⑧ Bag for accessories of the main unit (No. 2) <ul style="list-style-type: none"> Hook plate 2 Cord clamp Spacer Special screw ⑨ Bag for accessories of tuner amp unit <ul style="list-style-type: none"> Mounting bracket 2 Canoe clip 4 Machine screw (M4 × 8) 4 ⑩ Universal mounting bracket ⑪ Remote control unit ⑫ Battery <ul style="list-style-type: none"> (for remote control unit) ⑬ Outer Escutcheon ⑭ DCP Case |
|--|---|

3. GENERAL CAUTIONS

1. Do not open the case. There are no user serviceable parts inside. If you drop anything into the unit during installation, consult your dealer or an authorized CLARION service centre.
2. Use a soft, dry cloth to clean the case. Never use a rough cloth, thinner, benzine, or alcohol, etc. For tough dirt, apply a little cold or warm water to a soft cloth and wipe off the dirt gently.

4. CAUTIONS ON INSTALLATION

1. Prepare all articles necessary for installing the main unit before starting.
2. This model is used with the LCD panel slid forwards (shell loading system). On some types of cars, the LCD panel may touch the dashboard or shift lever, in which case it cannot be installed. Check that the set will not hamper operation of the shift lever before choosing the place of installation.(Figure 2)

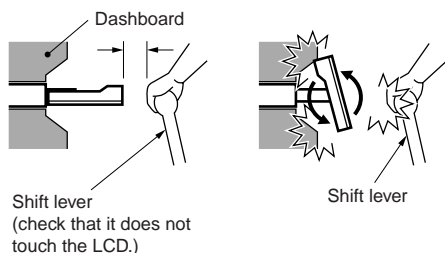

Figure 2

3. Install the unit within 30° of the horizontal plane. (Figure 3)

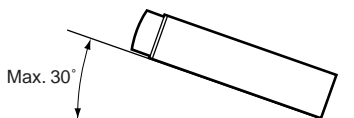

Figure 3

4. If you have to do any work on the car body, such as drilling holes, consult your car dealer beforehand.

5. Use the enclosed screws for installation. Using other screws can cause damage. (Figure 4)

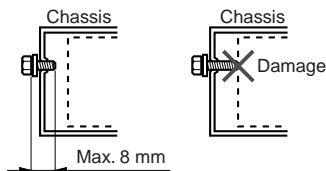

Figure 4

6. The source unit has mounting screw holes for NISSAN (N marks) and TOYOTA (T marks) vehicles.

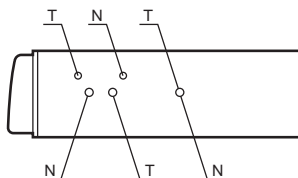

Figure 5

5. INSTALLING THE MAIN UNIT

■ Universal Mount

1. Place the universal mounting bracket into the instrument panel, use a screwdriver to bend each stopper of the universal mounting bracket inward, then secure the stopper as shown in Figure 6.
2. Wire as shown in Section 8.
3. Insert the main unit into the universal mounting bracket until it locks.
4. Mount the outer escutcheon so that all the hooks are locked.

Notes:

- 1) Some car models require special mounting kits for proper installation. Consult your Clarion dealer for details.
- 2) Fasten the front stopper securely to prevent the main unit from coming loose.

• Console opening dimensions

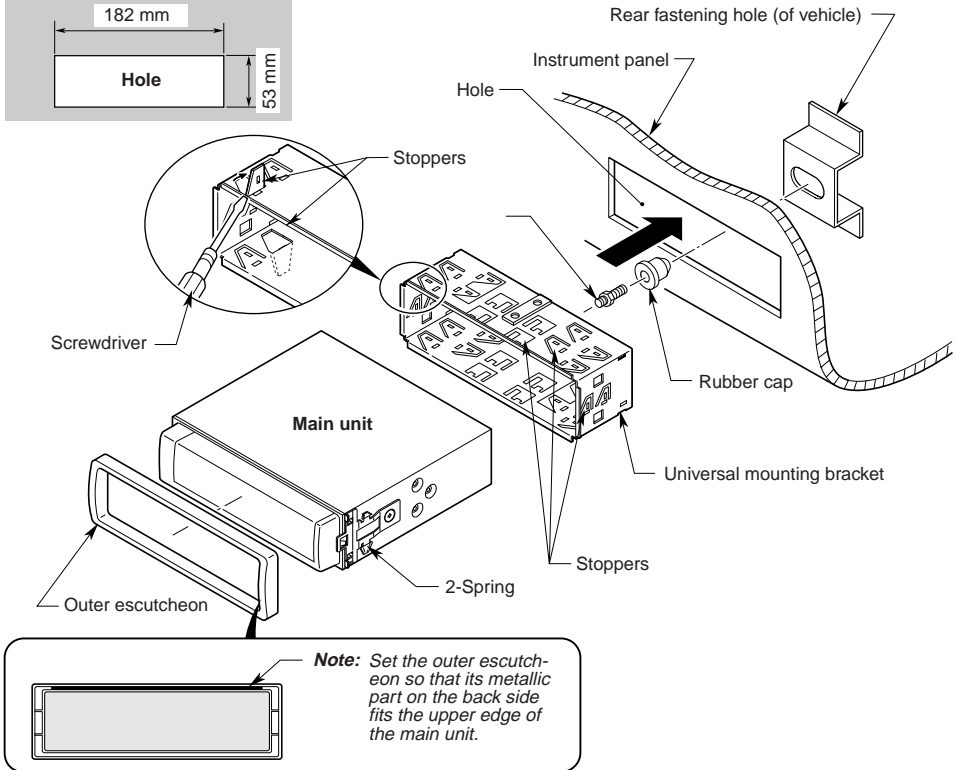
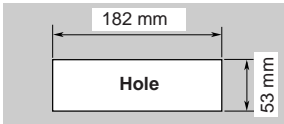

Figure 6

■ Fixed Mount (TOYOTA, NISSAN and other ISO/DIN equipped vehicles)

This unit is designed for fixed installation in the dashboard.

If the vehicle is equipped with a factory-installed radio, install the main unit with the parts and screws marked (*). (Figure 8)

If the vehicle is not equipped with a factory-installed radio, obtain an installation kit to install the main unit in the following procedure.

1. Remove the screws from both side of the main unit. Then, at either side, lift the leaf spring until the engaging claws are released from the holes, and slide the spring to the direction of

arrow to remove it. Repeat the same for the other side to remove the springs from the both sides. (Figure 7)

2. Secure the mounting brackets to the chassis as shown in Figure 8. Holes are pre-tapped for TOYOTA and NISSAN vehicles; modification, such as drilling new holes, of the mounting brackets may be required for other models.
3. Wire as shown in Section 8.
4. Secure the unit in the dashboard, and then reassemble the dashboard and the centre panel.

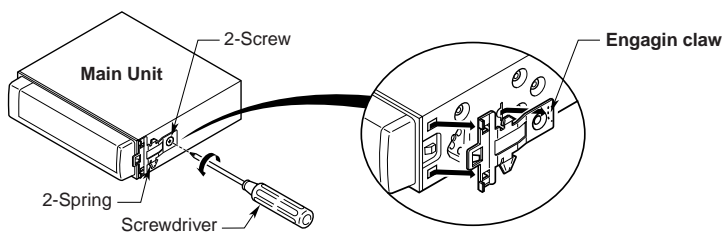
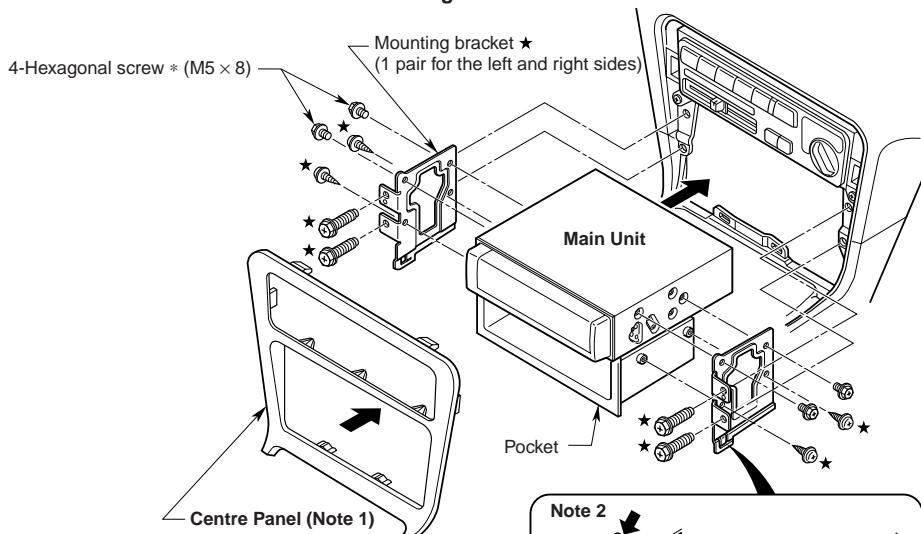

Figure 7



*: The screws with this mark are enclosed in this set.

★: The parts and screws with this mark are used to install radio or included in the installation kit.

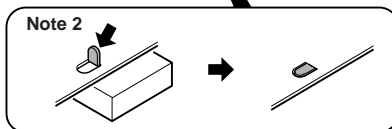

Figure 8

Note 1: In some cases, the centre panel may require some modification (trimming, filling, etc.).

Note 2: If a hook on the installation bracket interferes with the unit, bend and flatten it with a nipper or a similar tool.

6. REMOVING THE MAIN UNIT

1. When the rear of the main unit has been secured with the method shown in Figure 6 - unfasten the special screw.
2. Remove the outer escutcheon.
3. Insert the hook plate between the spring and the universal mounting bracket, fit tab **B** of the spring into hole **A** of the hook plate, then pull

the main unit out by the hook plate. (Insert both the right and left edges of the hook plate.) (Figure 9)

Note: Keep the hook plate. You cannot remove the main unit without disengaging the hook plate.

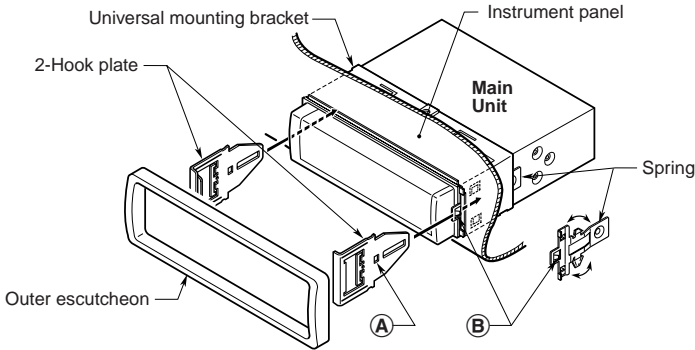

Figure 9

7. CAUTIONS ON WIRING

1. Be sure to turn the power off before wiring.
2. Be particularly careful where you route the wires.
Keep them well away from the engine, and exhaust pipe, etc. Heat may damage the wires.
3. If the fuse should blow, check to see if the wiring is correct.
If it is, replace the fuse with a new one with the same amperage rating as the original.
4. When any fuse is to be replaced, pull out the fuse (15A) at the rear of the tuner amp unit and put in a new one (Figure 10).

Rear view of the tuner amp unit

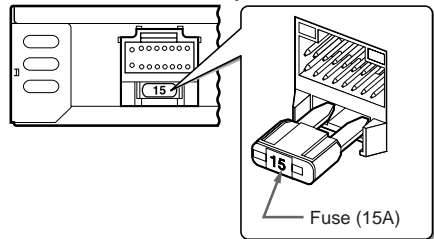

Figure 10

CAUTION

After the connection, fix the lead by a clamp or insulation tape for protection.

5. To replace the fuse, release the catch on the main unit side, remove the old fuse and insert the new one. (Figure 11)

Note: There are various types of fuse holder. Do not let the battery side touch other metal parts.

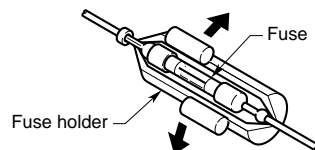
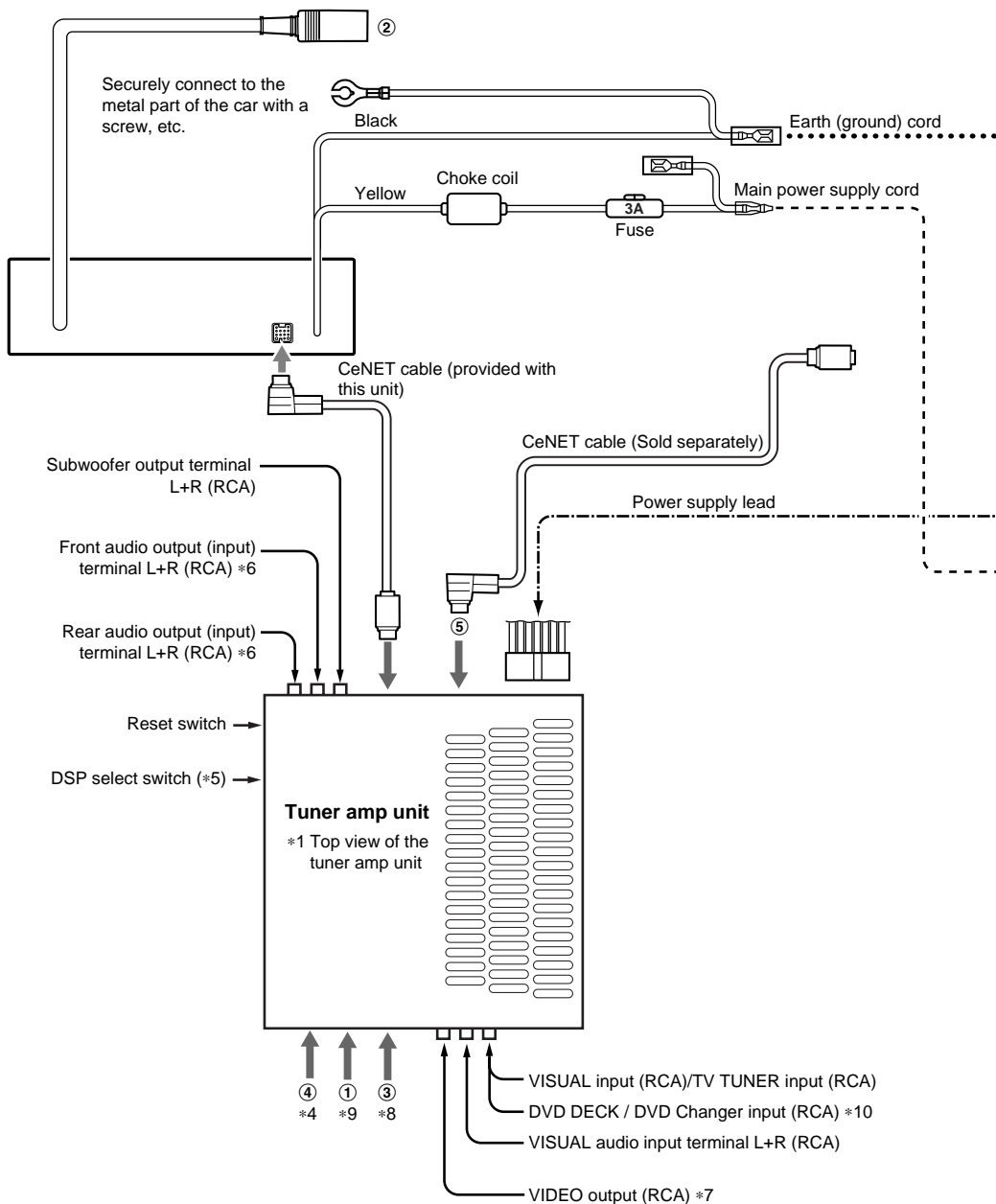
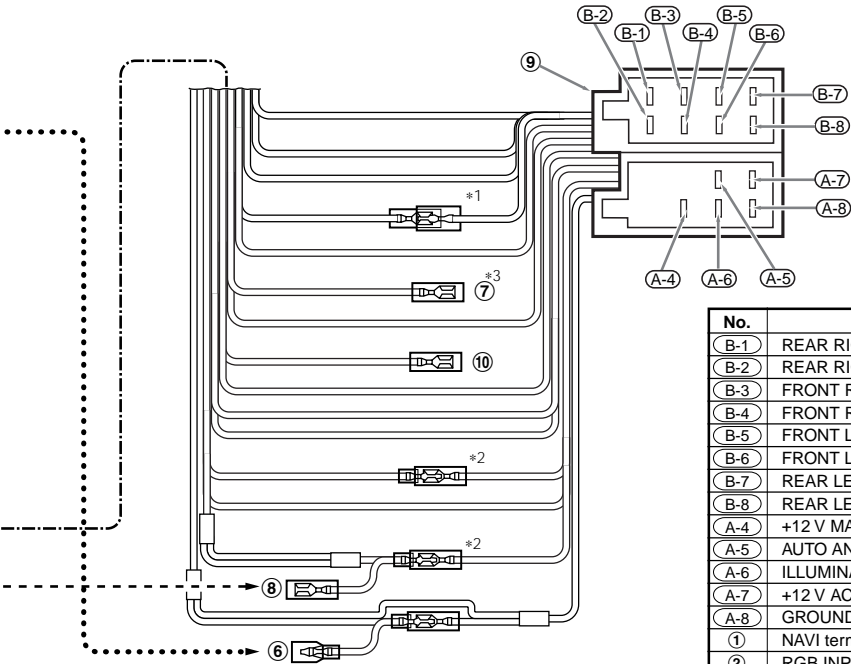

Figure 11

8. WIRE CONNECTION





No.	Description
(B-1)	REAR RIGHT ⊕
(B-2)	REAR RIGHT ⊖
(B-3)	FRONT RIGHT ⊕
(B-4)	FRONT RIGHT ⊖
(B-5)	FRONT LEFT ⊕
(B-6)	FRONT LEFT ⊖
(B-7)	REAR LEFT ⊕
(B-8)	REAR LEFT ⊖
(A-4)	+12 V MAIN POWER (*2)
(A-5)	AUTO ANTENNA (*1)
(A-6)	ILLUMINATION
(A-7)	+12 V ACCESSORY (*2)
(A-8)	GROUND
①	NAVI terminal
②	RGB INPUT
③	CCD/VISUAL 2 terminal
④	Radio antenna jack (*4)
⑤	CeNET terminal
⑥	Spare terminal (Black)
⑦	Phone mute (Brown) (*3)
⑧	Spare terminal (Yellow)
⑨	ISO CONNECTOR
⑩	Parking brake (Bright Green)

- *1: When the unit is installed in a **1998 or later Volkswagen** model, make sure to interrupt the <<Remote>> output. Disconnect the <<blue/white>> wire and insulate the front ends of this lead. A breakdown may occur if the lead is not disconnected, or front ends are not insulated.
- *2: In certain vehicles - **Volkswagen/Opel/Vauxhall** - it is necessary to exchange the accessory <<Red>> and the main power <<Yellow>> connection, to avoid overload and loss of memory.
- *3: Connecting the PHONE MUTE Terminal
The lead included with the unit must be connected to the specified position of the vehicle's ISO connector in order to use the "triggered audio mute for cellular telephones" function.
- *4: Use the attached extension lead when necessary. (Provided with this unit)
- Note:** Before making any installation, disconnect the car battery - (negative) cable.
- *5: When a DSP (sold separately) is connected and the internal amp of the Tuner Amp Unit is used, set the normal DSP select switch to "D". Then, the AUDIO OUT (IN) terminal of the Tuner Amp Unit is only available for audio input, not outputting the audio.



- *6: Connect to a separately sold amp, DSP, etc. with a separately sold RCA cord (L,R).
- *7: Connect to a separately sold Rear view monitor.
- *8: Connect to separately sold VTR equipment or security (CCD) camera.
- *9: Connect to a separately sold navigation device.
- *10: DVD DECK and DVD changer can not be connected at the same time.

■ Connecting the Accessories

• Connection to the external amplifier

The external amplifier cannot be connected unless the DSP is connected. For detailed information, refer to the instruction manual of the DSP.

• Connection to the CCD camera for vehicle

The CCD camera for vehicle can be connected to the system expansion terminal on the main unit. For detailed information, refer to the instruction sheet or manual for the CCD camera.

Notes:

- A power supply box (sold separately) is required for connection of the main unit and the CCD camera.
- While the CCD camera is used, the navigation cannot be turned on.
- The power supply box for camera CCA147 cannot be used. Please use the CCA188 instead.

• If the specified lead of the cellular phone is connected to the phone mute lead of the source unit, the audio mute is available when the cellular telephone is used.

For audio mute setting in cellular telephone use, see page 43.

• DAB (Digital Audio Broadcasting)

When the DAB is to be connected, use the CeNET connector. For detailed information, refer to the instruction manual of the DAB.

For DAB connection, the DAH913 can only be connected. The DAH9500Z cannot be connected.

• TV Tuner

When the TV TUNER is to be connected, connect the CeNET connector and RCA PIN (yellow). For detailed information, refer to the instruction manual of the TV TUNER.

■ Connecting the parking brake lead

Connect the lead to parking brake lamp earth in the meter panel.

Notes:

- Connecting the parking brake lead to lamp earth allows you to watch TV/VTR/DVD VIDEO/DVD Changer when the parking brake is engaged.
- When the parking brake lead is not connected, the monitor will stay off.

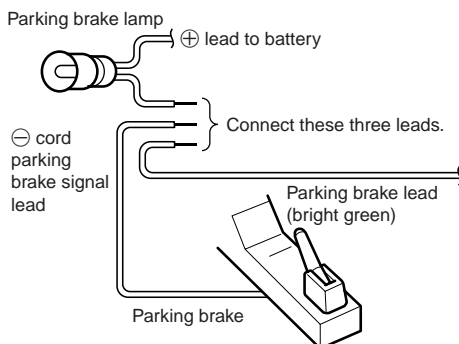

9. SAMPLE SYSTEMS

■ Sample System 1

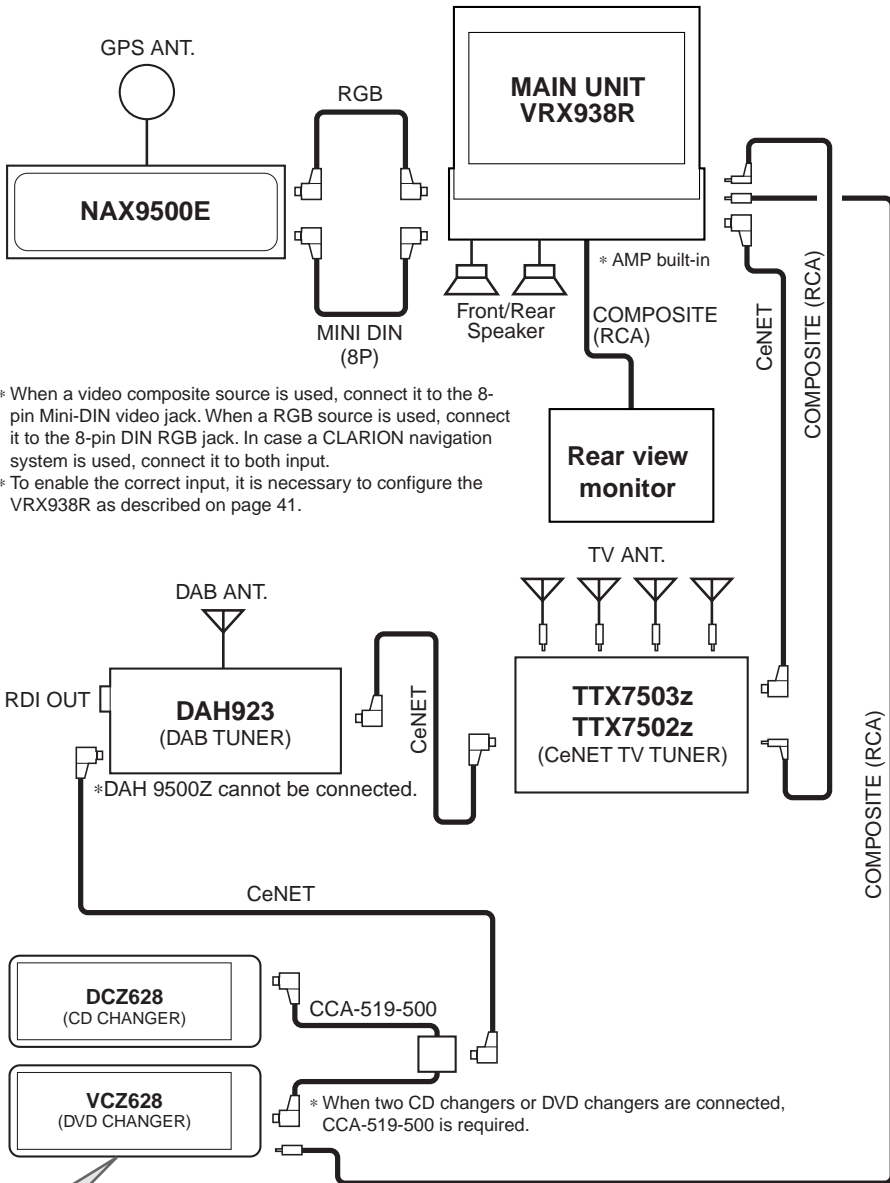

- * When a video composite source is used, connect it to the 8-pin Mini-DIN video jack. When a RGB source is used, connect it to the 8-pin DIN RGB jack. In case a CLARION navigation system is used, connect it to both input.
- * To enable the correct input, it is necessary to configure the VRX938R as described on page 41.

*DAH 9500Z cannot be connected.

* When two CD changers or DVD changers are connected, CCA-519-500 is required.

Set the [CeNET/STAND ALONE] switch to the [CeNET] position.

CeNET STAND ALONE

■ Sample System 2

