

Cub Cadet[®]

OPERATOR'S MANUAL

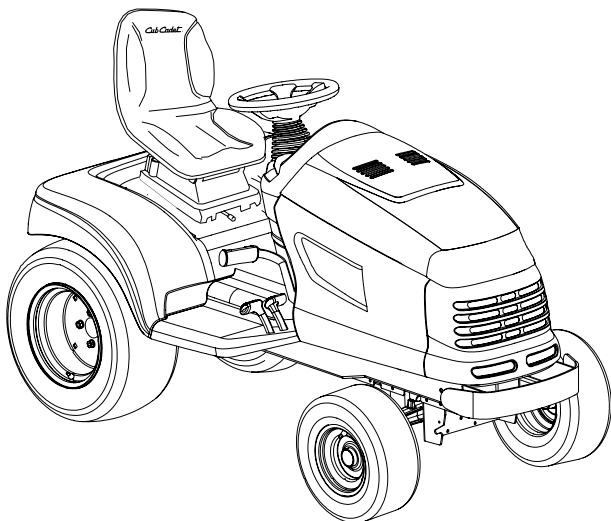

Series 3000 Tractor — Model GT 3200

IMPORTANT

READ SAFETY RULES AND INSTRUCTIONS CAREFULLY BEFORE OPERATION

Warning: This unit is equipped with an internal combustion engine and should not be used on or near any unimproved forest-covered, brush-covered or grass-covered land unless the engine's exhaust system is equipped with a spark arrester meeting applicable local or state laws (if any). If a spark arrester is used, it should be maintained in effective working order by the operator. In the State of California the above is required by law (Section 4442 of the California Public Resources Code). Other states may have similar laws. Federal laws apply on federal lands. A spark arrester for the muffler is available through your nearest engine authorized service dealer or contact the service department, P.O. Box 361131 Cleveland, Ohio 44136-0019.

CUB CADET LLC P.O. BOX 361131 CLEVELAND, OHIO 44136-0019 [www.cubcadet.com]

PRINTED IN U.S.A

FORM NO. 769-04425

Sept. 08

Section 1: To the Owner

Thank You

Thank you for purchasing a 3000 series tractor manufactured by Cub Cadet LLC. It was carefully engineered to provide excellent performance when properly operated and maintained.

Please read this entire manual prior to operating the equipment. It instructs you how to safely and easily set up, operate and maintain your machine. Please be sure that you, and any other persons who will operate the machine, carefully follow the recommended safety practices at all times. Failure to do so could result in personal injury or property damage.

All information in this manual is relative to the most recent product information available at the time of printing. Review this manual

frequently to familiarize yourself with the machine, its features and operation. Cub Cadet LLC reserves the right to change product specifications, designs and equipment without notice and without incurring obligation.

This product meets the rigid safety standards of the Outdoor Power Equipment Institute and an independent testing laboratory. If you have any problems or questions concerning the machine, phone your local Cub Cadet dealer or contact us directly. Cub Cadet's Customer Support telephone numbers, web site address and mailing address can be found on this page. We want to ensure your complete satisfaction at all times.

Throughout this manual, all references to right and left side of the machine are observed from the operating position.

Table of Contents

Section 2: Safe Operation Practices	3	Section 8: Engine Information	31
Section 3: Tractor Preparation	9	Section 9: Trouble Shooting	37
Section 4: Controls and Features	10	Section 10: Optional Equipment	38
Section 5: Operation	15	Section 11: Specifications	39
Section 6: Adjustments and Maintenance ...	20	Section 12: Replacement Parts	40
Section 7: Service	25	Warranties	41

Record Product Information

Before setting up and operating your new equipment, please locate the model plate on the equipment and record the information in the provided area to the right. This information will be necessary, should you seek technical support via our web site or with your local Cub Cadet dealer. The tractor model plate is located on the right frame rail behind the right front tire.

MODEL NUMBER

--	--	--	--	--	--	--	--	--	--	--	--	--	--	--	--	--	--	--	--	--

SERIAL NUMBER

--	--	--	--	--	--	--	--	--	--	--	--	--	--	--	--	--	--	--	--	--

Customer Support

If you have difficulty assembling this product or have any questions regarding the controls, operation, or maintenance of this machine, you can seek help from the experts. Choose from the options below:

- ◇ Visit us on the web at www.cubcadet.com
- ◇ Locate your nearest Cub Cadet Dealer at (877) 282-8684
- ◇ Write us at Cub Cadet LLC • P.O. Box 361131 • Cleveland, OH • 44136-0019

Section 2: Important Safe Operation Practices



WARNING: This symbol points out important safety instructions which, if not followed, could endanger the personal safety and/or property of yourself and others. Read and follow all instructions in this manual before attempting to operate this machine. Failure to comply with these instructions may result in personal injury. When you see this symbol. HEED ITS WARNING!

CALIFORNIA PROPOSITION 65



WARNING: Engine Exhaust, some of its constituents, and certain vehicle components contain or emit chemicals known to State of California to cause cancer and birth defects or other reproductive harm.



WARNING: Battery posts, terminals, and related accessories contain lead and lead compounds, chemicals known to the State of California to cause cancer and reproductive harm. Wash hands after handling.



DANGER: This machine was built to be operated according to the safe operation practices in this manual. As with any type of power equipment, carelessness or error on the part of the operator can result in serious injury. This machine is capable of amputating hands and feet and throwing objects. Failure to observe the following safety instructions could result in serious injury or death.

General Operation

1. Read, understand, and follow all instructions on the machine and in the manual(s) before attempting to assemble and operate. Keep this manual in a safe place for future and regular reference and for ordering replacement parts.
2. Be familiar with all controls and their proper operation. Know how to stop the machine and disengage them quickly.
3. Never allow children under 14 years of age to operate this machine. Children 14 and over should read and understand the instructions and safe operation practices in this manual and on the machine and should be trained and supervised by an adult.
4. Never allow adults to operate this machine without proper instruction.
5. To help avoid blade contact or a thrown object injury, keep bystanders, helpers, children and pets at least 75 feet from the machine while it is in operation. Stop machine if anyone enters the area.
6. Thoroughly inspect the area where the equipment is to be used. Remove all stones, sticks, wire, bones, toys, and other foreign objects which could be picked up and thrown by the blade(s). Thrown objects can cause serious personal injury.
7. Plan your mowing pattern to avoid discharge of material toward roads, sidewalks, bystanders and the like. Also, avoid discharging material against a wall or obstruction which may cause discharged material to ricochet back toward the operator.
8. Always wear safety glasses or safety goggles during operation and while performing an adjustment or repair to protect your eyes. Thrown objects which ricochet can cause serious injury to the eyes.
9. Wear sturdy, rough-soled work shoes and close-fitting slacks and shirts. Loose fitting clothes and jewelry can be caught in movable parts. Never operate this machine in bare feet or sandals.
10. Be aware of the mower and attachment discharge direction and do not point it at anyone. Do not operate the mower without the discharge cover or entire grass catcher in its proper place.

11. Do not put hands or feet near rotating parts or under the cutting deck. Contact with the blade(s) can amputate hands and feet.
12. A missing or damaged discharge cover can cause blade contact or thrown object injuries.
13. Stop the blade(s) when crossing gravel drives, walks, or roads and while not cutting grass.
14. Watch for traffic when operating near or crossing roadways. This machine is not intended for use on any public roadway.
15. Do not operate the machine while under the influence of alcohol or drugs.
16. Mow only in daylight or good artificial light.
17. Never carry passengers.
18. Disengage blade(s) before shifting into reverse. Back up slowly. Always look down and behind before and while backing to avoid a back-over accident.
19. Slow down before turning. Operate the machine smoothly. Avoid erratic operation and excessive speed.
20. Disengage blade(s), set parking brake, stop engine and wait until the blade(s) come to a complete stop before removing grass catcher, emptying grass, unclogging chute, removing any grass or debris, or making any adjustments.
21. Never leave a running machine unattended. Always turn off blade(s), place transmission in neutral, set parking brake, stop engine and remove key before dismounting.
22. Use extra care when loading or unloading the machine into a trailer or truck. This machine should not be driven up or down ramp(s), because the machine could tip over, causing serious personal injury. The machine must be pushed manually on ramp(s) to load or unload properly.
23. Muffler and engine become hot and can cause a burn. Do not touch.
24. Check overhead clearances carefully before driving under low hanging tree branches, wires, door openings etc., where the operator may be struck or pulled from the machine, which could result in serious injury.
25. Disengage all attachment clutches, depress the brake pedal completely and shift into neutral before attempting to start engine.
26. Your machine is designed to cut normal residential grass of a height no more than 10". Do not attempt to mow through unusually tall, dry grass (e.g., pasture) or piles of dry leaves. Dry grass or leaves may contact the engine exhaust and/or build up on the mower deck presenting a potential fire hazard.
27. Use only accessories and attachments approved for this machine by the machine manufacturer. Read, understand and follow all instructions provided with the approved accessory or attachment.
28. Data indicates that operators, age 60 years and above, are involved in a large percentage of riding mower-related injuries. These operators should evaluate their ability to operate the riding mower safely enough to protect themselves and others from serious injury.
29. If situations occur which are not covered in this manual, use care and good judgment. Contact your customer service representative for assistance.

Slope Operation

Slopes are a major factor related to loss of control and tip-over accidents which can result in severe injury or death. All slopes require extra caution. If you cannot back up the slope or if you feel uneasy on it, do not mow it.

For your safety, use the slope gauge included as part of this manual to measure slopes before operating this machine on a sloped or hilly area. If the slope is greater than 15 degrees as shown on the slope gauge, do not operate this machine on that area or serious injury could result.

Do:

1. Mow up and down slopes, not across. Exercise extreme caution when changing direction on slopes.
2. Watch for holes, ruts, bumps, rocks, or other hidden objects. Uneven terrain could overturn the machine. Tall grass can hide obstacles.

3. Use slow speed. Choose a low enough speed setting so that you will not have to stop or shift while on the slope. Tires may lose traction on slopes even though the brakes are functioning properly. Always keep machine in gear when going down slopes to take advantage of engine braking action.
4. Follow the manufacturer's recommendations for wheel weights or counterweights to improve stability.
5. Use extra care with grass catchers or other attachments. These can change the stability of the machine.
6. Keep all movement on the slopes slow and gradual. Do not make sudden changes in speed or direction. Rapid engagement or braking could cause the front of the machine to lift and rapidly flip over backwards which could cause serious injury.
7. Avoid starting or stopping on a slope. If tires lose traction, disengage the blade(s) and proceed slowly straight down the slope.

Do Not:

1. Do not turn on slopes unless necessary; then, turn slowly and gradually downhill, if possible.
2. Do not mow near drop-offs, ditches or embankments. The mower could suddenly turn over if a wheel is over the edge of a cliff, ditch, or if an edge caves in.
3. Do not try to stabilize the machine by putting your foot on the ground.
4. Do not use a grass catcher on steep slopes.
5. Do not mow on wet grass. Reduced traction could cause sliding.
6. Do not shift to neutral and coast downhill. Over-speeding may cause the operator to lose control of the machine resulting in serious injury or death.
7. Do not tow heavy pull behind attachments (e.g. loaded dump cart, lawn roller, etc.) on slopes greater than 5 degrees. When going down hill, the extra weight tends to push the tractor and may cause you to

lose control (e.g. tractor may speed up, braking and steering ability are reduced, attachment may jack-knife and cause tractor to overturn).

Children

1. Tragic accidents can occur if the operator is not alert to the presence of children. Children are often attracted to the machine and the mowing activity. They do not understand the dangers. Never assume that children will remain where you last saw them.
 - a. Keep children out of the mowing area and in watchful care of a responsible adult other than the operator.
 - b. Be alert and turn machine off if a child enters the area.
 - c. Before and while backing, look behind and down for small children.
 - d. Never carry children, even with the blade(s) shut off. They may fall off and be seriously injured or interfere with safe machine operation.
 - e. Use extreme care when approaching blind corners, doorways, shrubs, trees or other objects that may block your vision of a child who may run into the path of the machine.
 - f. To avoid back-over accidents, always disengage the cutting blade(s) before shifting into Reverse. If equipped, the "Reverse Caution Mode" should not be used when children or others are around.**
 - g. Keep children away from hot or running engines. They can suffer burns from a hot muffler.
 - h. Remove key when machine is unattended to prevent unauthorized operation.
2. Never allow children under 14 years of age to operate this machine. Children 14 and over should read and understand the instructions and safe operation practices in this manual and on the machine and should be trained and supervised by an adult.

Towing

1. Tow only with a machine that has a hitch designed for towing. Do not attach towed equipment except at the hitch point.
2. Follow the manufacturers recommendation for weight limits for towed equipment and towing on slopes.
3. Never allow children or others in or on towed equipment.
4. On slopes, the weight of the towed equipment may cause loss of traction and loss of control.
5. Travel slowly and allow extra distance to stop.
6. Do not shift to neutral and coast downhill.

Service

Safe Handling of Gasoline:

1. To avoid personal injury or property damage use extreme care in handling gasoline. **Gasoline is extremely flammable and the vapors are explosive.** Serious personal injury can occur when gasoline is spilled on yourself or your clothes which can ignite. Wash your skin and change clothes immediately.
 - a. Use only an approved gasoline container.
 - b. Never fill containers inside a vehicle or on a truck or trailer bed with a plastic liner. Always place containers on the ground away from your vehicle before filling.
 - c. When practical, remove gas-powered equipment from the truck or trailer and refuel it on the ground. If this is not possible, then refuel such equipment on a trailer with a portable container, rather than from a gasoline dispenser nozzle.
 - d. Keep the nozzle in contact with the rim of the fuel tank or container opening at all times until fueling is complete. Do not use a nozzle lock-open device.
 - e. Extinguish all cigarettes, cigars, pipes and other sources of ignition.
 - f. Never fuel machine indoors.
 - g. Never remove gas cap or add fuel while the engine is hot or running. Allow en-

gine to cool at least two minutes before refueling.

- h. Never over fill fuel tank. Fill tank to no more than ½ inch below bottom of filler neck to allow space for fuel expansion.
- i. Replace gasoline cap and tighten securely.
- j. If gasoline is spilled, wipe it off the engine and equipment. Move machine to another area. Wait 5 minutes before starting the engine.
- k. To reduce fire hazards, keep machine free of grass, leaves, or other debris build-up. Clean up oil or fuel spillage and remove any fuel soaked debris.
- l. Never store the machine or fuel container inside where there is an open flame, spark or pilot light as on a water heater, space heater, furnace, clothes dryer or other gas appliances.
- m. Allow a machine to cool at least five minutes before storing.

General Service

1. Never run an engine indoors or in a poorly ventilated area. Engine exhaust contains carbon monoxide, an odorless, and deadly gas.
2. Before cleaning, repairing, or inspecting, make certain the blade(s) and all moving parts have stopped. Disconnect the spark plug wire and ground against the engine to prevent unintended starting.
3. Periodically check to make sure the blades come to complete stop within approximately (5) five seconds after operating the blade disengagement control. If the blades do not stop within the this time frame, your machine should be serviced professionally by an authorized Cub Cadet Service Dealer.
4. Check brake operation frequently as it is subjected to wear during normal operation. Adjust and service as required.
5. Check the blade(s) and engine mounting bolts at frequent intervals for proper tightness. Also, visually inspect blade(s) for damage (e.g., excessive wear, bent, cracked). Replace the blade(s) with

the original equipment manufacturer's (O.E.M.) blade(s) only, listed in this manual. "Use of parts which do not meet the original equipment specifications may lead to improper performance and compromise safety!"

6. Mower blades are sharp. Wrap the blade or wear gloves, and use extra caution when servicing them.
7. Keep all nuts, bolts, and screws tight to be sure the equipment is in safe working condition.
8. Never tamper with the safety interlock system or other safety devices. Check their proper operation regularly.
9. After striking a foreign object, stop the engine, disconnect the spark plug wire(s) and ground against the engine. Thoroughly inspect the machine for any damage. Repair the damage before starting and operating.
10. Never attempt to make adjustments or repairs to the machine while the engine is running.
11. Grass catcher components and the discharge cover are subject to wear and damage which could expose moving parts or allow objects to be thrown. For safety protection, frequently check components and replace immediately with original equipment manufacturer's (O.E.M.) parts only, listed in this manual. "Use of parts which do not meet the original equipment specifications may lead to improper performance and compromise safety!"
12. Do not change the engine governor settings or over-speed the engine. The governor controls the maximum safe operating speed of the engine.
13. Maintain or replace safety and instruction labels, as necessary.
14. Observe proper disposal laws and regulations for gas, oil, etc. to protect the environment.

Do Not Modify Engine

To avoid serious injury or death, do not modify engine in any way. Tampering with the governor setting can lead to a runaway engine and cause it to operate at unsafe speeds.

Never tamper with factory setting of engine governor.

Notice Regarding Emissions

Engines which are certified to comply with California and federal EPA emission regulations for SORE (Small Off Road Equipment) are certified to operate on regular unleaded gasoline, and may include the following emission control systems: Engine Modification (EM) and Three Way Catalyst (TWC) if so equipped.

Spark Arrestor



WARNING: This machine is equipped with an internal combustion engine and should not be used on or near any unimproved forest-covered, brush covered or grass-covered land unless the engine's exhaust system is equipped with a spark arrester meeting applicable local or state laws (if any).

If a spark arrester is used, it should be maintained in effective working order by the operator. In the State of California the above is required by law (Section 4442 of the California Public Resources Code). Other states may have similar laws. Federal laws apply on federal lands.

A spark arrester for the muffler is available through your nearest engine authorized service dealer or contact the service department, P.O. Box 361131 Cleveland, Ohio 44136-0019.

Average Useful Life

According to the Consumer Products Safety Commission (CPSC) and the U.S. Environmental Protection Agency (EPA), this product has an *Average Useful Life* of seven (7) years, or 390 hours of operation.

At the end of the *Average Useful Life*, buy a new machine or have the machine inspected annually by an authorized service dealer to ensure that all mechanical and safety systems are working properly and not worn excessively. Failure to do so can result in accidents, injuries or death.

Slope Guide

Use this page as a guide to determine slopes where you may not operate safely. **Do not operate** your tractor on such slopes.

Operate Garden Tractors up and down slopes, never across the face of slopes.



WARNING: Do not mow on inclines with a slope in excess of 15 degrees (a rise of approximately 2-1/2 feet every 10 feet).

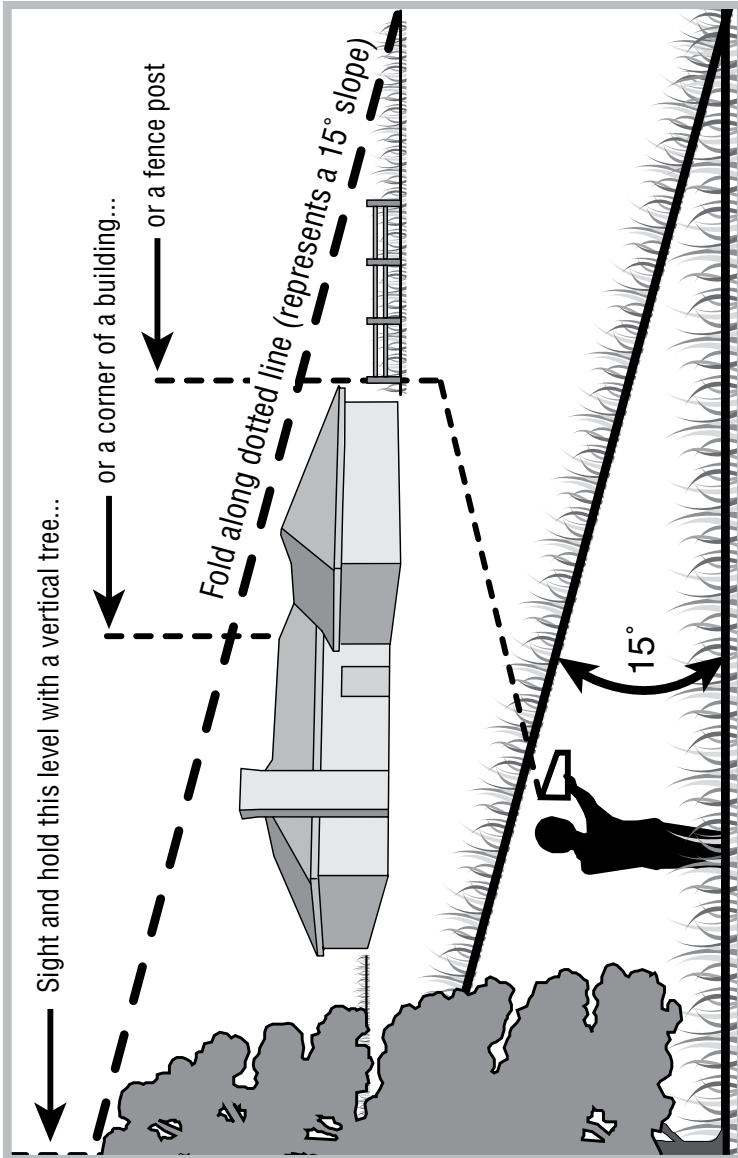

SECTION 3: TRACTOR PREPARATION

Connect the Battery



Battery posts, terminals and related accessories contain lead and lead compounds. Wash hands after handling.

The tractor is shipped with a sealed battery, with the positive battery cable factory connected. The negative cable must be connected.

Note: Make sure the ignition switch is in the "OFF" position before attaching the battery cable.

- Open the tractor hood. Remove the upper bulkhead baffle from the front of the dash panel by lifting upward on the locking tab on each side of the baffle.
- Remove the protective cap from the negative terminal of the battery.
- Connect the black battery cable to the negative battery post. Slide terminal cover over the connection and reinstall the upper baffle.

Position the High Back Seat

For shipping purposes the seat is installed sideways. Reposition the seat as follows:

- Remove from the seat the two screws NOT fastening the seat to the hinge brackets.
- Loosen the RH screw and remove the LH screw from the seat and hinge bracket.
- Rotate the rear of the seat to the *right* and align the four front seat holes with matching holes in the LH and RH hinge brackets.

- Temporarily install the three previously removed screws into the three open front seat holes.
- See Section 8: **Adjustments** for final seat adjustment procedures.

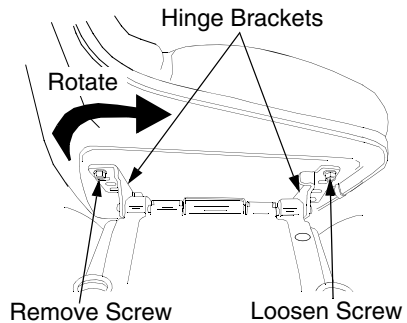

Deck Front Lift Rod Assembly

For shipping purposes, the deck front lift rod assembly has been installed on the tractor. Cut the tie strap holding the lift rod assembly to the tractor; then pull downward on the quick latch rod at the front of the tractor to remove the lift rod assembly.

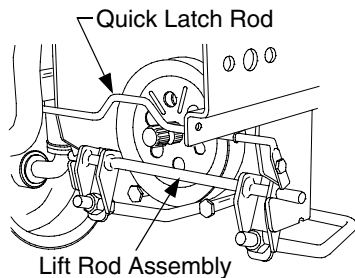

SECTION 4: CONTROLS and FEATURES

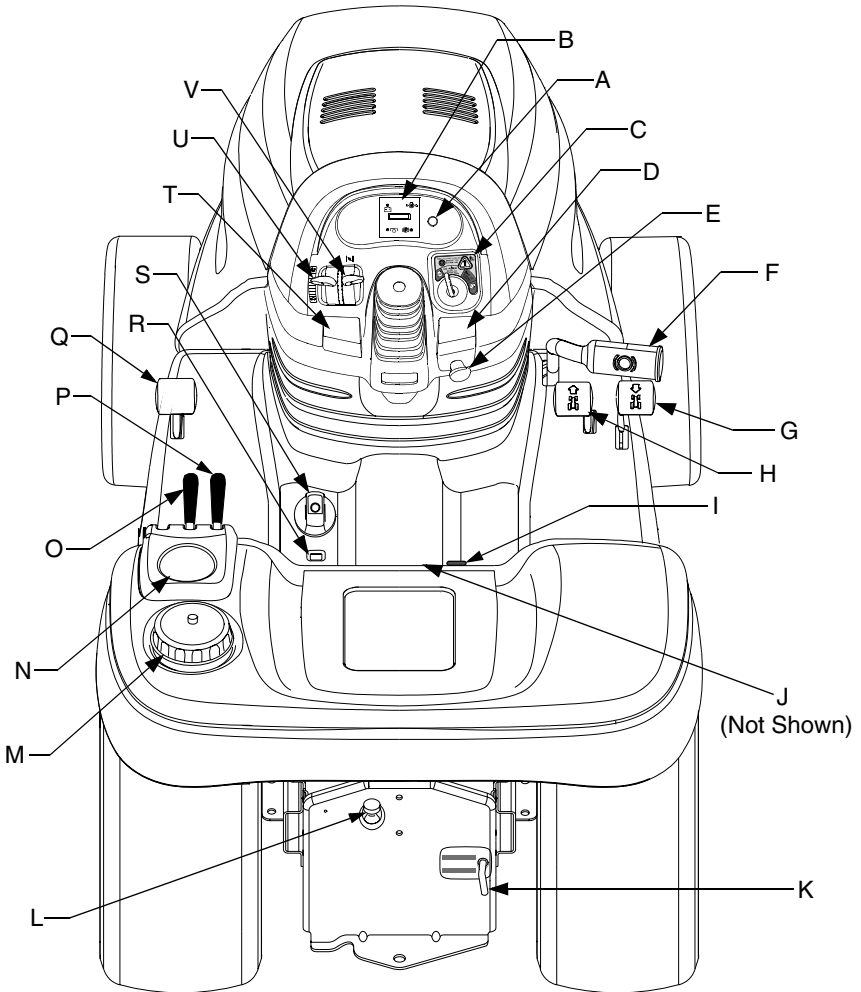

Figure 1

- | | | | |
|---|-----------------------------------|---|----------------------------------|
| A | Low Fuel Indicator Lamp | L | Transmission Oil Fill/Dipstick |
| B | Indicator Panel/Hour Meter | M | Fuel Fill Cap |
| C | Key Switch Module | N | Cup Holder |
| D | Parking Brake Lever | O | Hydraulic Lift Lever |
| E | PTO Switch | P | Auxiliary Hydraulic Lever |
| F | Brake Pedal | Q | Differential Lock Pedal |
| G | Reverse Pedal | R | Center Height Position Indicator |
| H | Forward Pedal | S | Deck Height Adjustment Knob |
| I | 12V Power Outlet | T | Cruise Control Lever |
| J | Seat Adjustment Lever (Not Shown) | U | Throttle Lever |
| K | Transmission Release Rod | V | Choke Lever |

* Steering Wheel and Seat Removed For Clarity

NOTE: References to LEFT and RIGHT indicate that side of the tractor when facing forward while seated in the drivers seat. Reference to FRONT indicates the grille end of the tractor; to REAR, the drawbar end.

Steering Wheel

The steering wheel, centered on the dash panel, is used to turn the tractor left or right while driving.

NOTE: This tractor is equipped with hydraulic power steering. With this feature, the center of the steering wheel may not stay center aligned.

A. Low Fuel Indicator Lamp

The Low Fuel indicator lamp is on the dash panel. This indicator will illuminate when the tractor is low on fuel.

B. Indicator Panel/Hour Meter

The indicator panel/hour meter uses indicator lights to display the status of various functions of the tractor and also records the accumulated hours of operation. The Indicator Panel Features are as follows. Refer to Figure 2.

Oil Pressure Indicator

- This warning lamp indicates low engine oil pressure. If this indicator illuminates, stop the tractor immediately and check the engine oil level. If the oil level is within the operating range, but the light remains on, contact your *Cub Cadet* dealer.

NOTE: The oil pressure indicator may illuminate when the key switch is turned to an on position, but should turn off when the engine is started.

PTO Engaged Indicator

- This indicator illuminates when the key switch is turned to the "Start" position while the PTO switch is pulled outward in the "Engaged" position. Check this indicator if the engine will not crank with the key switch in the "Start" position. If necessary, move the PTO switch to the "Disengaged" position.

Brake Engaged Indicator

- This indicator illuminates when the key switch is turned to the "Start" position and the brake pedal is not fully depressed. Check this indicator if the engine will not crank with the key switch in the "Start" position. If necessary, fully depress the brake pedal.

Brake Engaged Indicator

- This indicator illuminates when the key switch is turned to the "Start" position and the brake pedal is not fully depressed. Check this indicator if the engine will not crank with the key switch in the "Start" position. If necessary, fully depress the brake pedal.

LCD Hour Meter Display

The hour meter shows the hours (tenths of an hour - *right* most digit) that the tractor has been operated.

The hour meter display is activated when the key switch is turned to either the "Normal Mowing" or the "Reverse Caution Mode" switch positions. When the key switch is turned to an on position, the battery indicator light briefly illuminates and the battery voltage is briefly displayed. The display then changes to the accumulated hours.

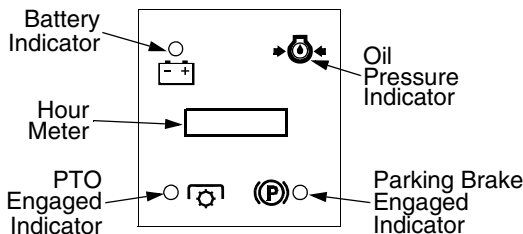

Figure 2

NOTE: A record of the actual hours of operation should be kept to assure maintenance procedures are completed according to the schedule in this manual.

The Indicator Monitor will also remind the operator of maintenance intervals for changing the engine oil. The LCD will alternately flash the recorded hours, “CHG” and “OIL” for five minutes, after every 50 hours of recorded operation elapse. The maintenance interval lasts for two hours (from 50-52, 100-102, 150-152, etc.). The LCD will flash as described for five minutes every time the tractor’s engine is started during this maintenance interval. Follow the oil change intervals specified in the **Maintenance** section of this Manual and the engine manual.

C. Key Switch Module

The key switch module consist of a four position key switch, the “Reverse Push Button”, and a red indicator light. Refer to Figure 3.

The four key positions of key switch module (Refer to Figure 3) and their functions are as follows:

- **Stop** — Stops the tractor engine and shuts down the tractor’s electrical circuits.
- **Reverse Caution Mode** — This position allows the machine to be operated in reverse with the blades (PTO) engaged.
- **Normal Mowing** — The normal operating position. All safety inter-

lock circuits are activated and the blades (PTO) will disengage when the tractor is driven in the reverse direction.

- **Start** — Energizes the starter motor to crank and start the tractor engine. Release the key as soon as the engine starts and the key will return to “NORMAL MOWING” position.



To prevent accidental starting, remove the key from the key switch when the tractor is not in use.

Reverse Push Button — The orange/triangular button at the top/right corner of the key switch module activates the system which allows the tractor’s blades (PTO) to remain engaged when the tractor is driven in the reverse direction. The key must be turned to the “REVERSE CAUTION MODE” and the operator must be in the tractor seat prior to depressing the button to activate the system.

The **Red Indicator Light** at the top/left corner of the key switch module comes “ON” to alert the operator that the key has been turned to the “Reverse Caution Mode” position, the “Reverse Push Button” has been depressed, and that the blades will remain engaged when the machine is driven in reverse.

IMPORTANT: *Mowing in reverse is not recommended.*

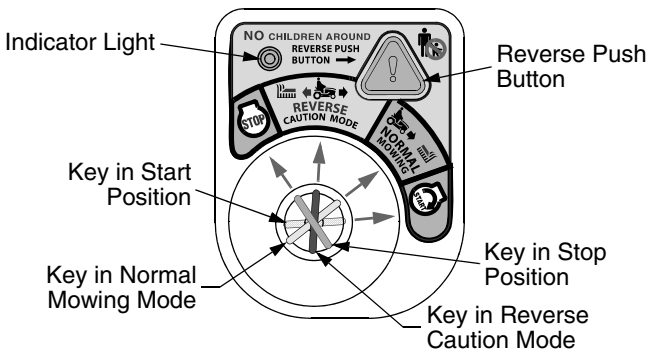

Figure 3

D. Parking Brake Lever



Figure 4

The parking brake lever is located to the right of the steering wheel in the dash panel. With the brake pedal depressed fully, push the parking brake lever downward and release the brake pedal to lock the parking brake.

E. PTO Switch

The PTO switch is located on the lower/right side the dash panel. Pull the knob outward to engage the PTO clutch. Push the knob inward to disengage the PTO clutch.

F. Brake Pedal



Figure 5

The brake pedal is located at the front of the right running board above the forward and reverse pedals. Depress to stop the tractor and disengage the cruise control. Fully depress the brake pedal to activate the safety interlock switch when starting the tractor.

G. Reverse Pedal



Figure 6



WARNING: Always look down and behind before and while backing. Do not operate the tractor when children or others are around. Stop the tractor immediately if someone enters the area.

The reverse control pedal is located below the brake pedal. Depress the pedal to move in reverse.

H. Forward Pedal

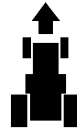

Figure 7

The forward control pedal is located on the right running board below the brake pedal. Slowly press down on the pedal to start moving forward. The forward ground speed of the tractor is directly affected by the distance the pedal is depressed.

I. 12V Power Outlet

The 12V power outlet is located on the front/right surface of the fender, below the seat. It is used for the convenience of plugging in accessories that require a power source with a maximum load of 5 amps at 12 volts.

J. Seat Adjustment Lever

The seat adjustment lever is located below the seat. This lever is used to adjust the seat forward or backward.

K. Transmission Release Rod

The transmission release rod is located at the back of the tractor in the draw bar. This rod, when engaged, allows the tractor to be pushed short distances by hand.

To disengage the transmission, pull back on the rod until its locking flange is visible outside the drawbar, then lower the rod into the slot and release.

To reengage the transmission, pull back on the rod, lift out of the slot and release.

L. Transmission Oil Fill/Dipstick

The transmission oil fill/dipstick is located at the back of the tractor in the rear draw bar. The handle of the transmission oil dipstick serves as the fill tube plug and should fit snugly in the fill tube.

M. Fuel Fill Cap

The fuel fill cap is located on the fender to the left of the seat.

N. Cup Holder

The cup holder is located on the fender to the left of the seat.

O. Hydraulic Lift Lever

The hydraulic lift lever is located on the fender to the left of the seat. This lever is used to operate the tractor's center lift system.

P. Auxiliary Hydraulic Lever

The auxiliary hydraulic lever is located on the left fender. Use this lever to control attachments connected to the auxiliary hydraulic outlets.

Q. Differential Lock Pedal

Located at the front of the left running board. Depressing the diff. lock pedal engages the transmission differential lock, which improves traction at the rear wheels when operating on uneven terrain or in slippery conditions. **NOTE:** Use care when engaging the differential lock on manicured turf where turns are required. Damage to the turf could occur.

Depressing the brake pedal also actuates the diff. lock pedal. Make certain the diff. lock disengages when the brake pedal is released.

R. Center Lift Height Indicator

The center lift height indicator is located in the left running board. This indicator shows the operator the relative height position of the hydraulic center lift system. The lower number indicates a lower setting.

S. Deck Height Adjustment Knob

The deck height adjustment knob is located on the left running board (See Figure 8). Use this knob to set and hold your desired downstop position for the mower deck.

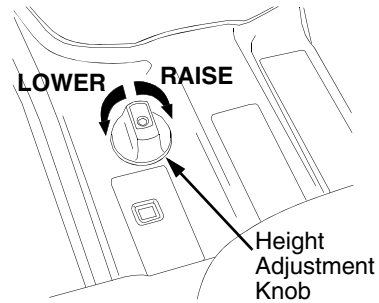

Figure 8

Each full rotation of the adjustment knob equals approximately a 1/4 inch adjustment in the deck height setting, and there are four detent positions per rotation.

Always use the tractor lift system to raise the deck before turning the adjustment knob.

T. Cruise Control Lever



Figure 9

The cruise control lever is located to the left of the steering wheel. Push the cruise control lever downward while traveling at the desired forward speed to engage the cruise control.

U. Throttle Lever



This symbol shows the fast position.



This symbol shows the slow position

The throttle lever is located to the left of the steering wheel in the throttle/choke lever pod. When set in a given position, the throttle lever will maintain a uniform engine speed. Push the lever forward to increase the engine speed.

IMPORTANT: *When using power take-off operated equipment, best performance is achieved with the throttle lever in the “FAST” position.*

V. Choke Lever

The choke lever is located to the left of the steering wheel in the throttle/choke lever pod. Push the lever forward to close the engine choke plate.

SECTION 5: OPERATION

Safety Interlock Switches

This tractor is equipped with a safety interlock system for the protection of the operator. If the interlock system should ever malfunction, do not operate the tractor. Contact your authorized *Cub Cadet* Dealer. The safety interlock system prevents the engine from cranking or starting unless the brake pedal is fully depressed, and the PTO is “OFF”.

- The safety interlock system will automatically shut off the engine if the operator leaves the seat before engaging the brake lock.
- The safety interlock system will automatically shut off the engine if the operator leaves the seat with the PTO “ON”, regardless of whether the brake lock is engaged. The PTO switch must be “OFF” to restart the engine.
- **With key switch in “NORMAL MOWING” position:** The safety interlock system will automatically shut off the PTO if the *reverse control pedal* is depressed with the PTO “ON”. To re-engage the PTO, release the reverse control pedal, push the PTO switch inward to the “OFF” position, then pull the PTO switch outward to engage the PTO.

Fueling The Tractor

NOTE: *Some fuels, called oxygenated or reformulated gasolines, are gasoline blended with alcohols or ethers. Gasolines blended with either ethyl alcohol (Max. 10%) or methyl tertiary butyl ether (MTBE, Max. 15%) are approved as fuels for this engine. If any undesirable operating symp-*

toms occur, use gasoline with a lower percentage of these blends. Do not use gasoline which contains Methanol or other alcohol blends. For best results use only clean, fresh, unleaded gasoline with an octane rating of 87 or higher. Purchase fuel in a quantity that can be used within 30 days to assure fuel freshness. Do not use gasoline left over from the previous season to minimize gum deposits in the fuel system. Leaded gasoline is NOT RECOMMENDED and must not be used where exhaust emissions are regulated.

Do not fill the fuel tank when the engine is running or while the engine is hot. Tighten the fuel cap securely.

Unscrew the fuel cap and fill the fuel tank from an approved gasoline container.

Starting The Engine

- Operator must be sitting in the tractor seat.
- Push choke lever to the full choke position. Less choking may be necessary due to variations in temperature, grade of fuel, etc. Little or no choking will be needed when the engine is warm.
- Place the throttle midway between the “SLOW” and “FAST” position.
- Make sure the PTO switch is in the “OFF” position.
- Fully depress the brake pedal.
- Turn the ignition key clockwise to the “START” position and release it as soon as the engine starts. However, do not crank the engine

continuously for more than 10 seconds at a time. If the engine does not start within this time, turn the key to “STOP” and wait a minute to allow the engine’s starter motor to cool. Try again after waiting.

- After the engine starts, slowly release the brake pedal. As the engine warms up, gradually pull the choke lever all the way back. Do not use the choke to enrich the fuel mixture, except when necessary to start the engine.

Stopping The Engine

NOTE: Remove the key from the ignition switch to prevent accidental starting or battery discharge if the equipment is left unattended.

- Place the PTO switch in the “OFF” position. Place the throttle control lever between the “MID” and “FAST” positions. Then turn the ignition key to the “STOP” position and remove the key from the ignition switch.

Driving The Tractor



WARNING: Avoid sudden starts, excessive speed and sudden stops.



WARNING: Do not leave the seat of the tractor without disengaging the PTO and engaging the parking brake. If leaving the tractor unattended, turn the ignition key off and remove key.

- Depress the brake pedal to release the parking brake and let the pedal up. Move the throttle lever to the position where the engine operates best for the load to be handled (normally full throttle).

NOTE: Do not use the forward or reverse control pedals to change the direction of travel when the tractor is in

motion. Use the brake pedal to bring the tractor to a stop before depressing either the forward or reverse control pedal.

- To move forward, slowly depress the forward control pedal until the desired speed is achieved.
- To move in reverse, check that the area behind is clear then slowly depress the reverse control pedal. Always look down and behind before and while backing up.

Setting The Cruise Control

NOTE: The cruise control feature can only be operated in the forward direction.

- Slowly depress the forward control pedal until the desired speed is achieved.
- Lightly push the cruise control lever downward.
- While continuing to hold the cruise lever down, lift your foot from the forward control pedal (you should feel the cruise latch engage).
- If properly engaged, the cruise lever and forward control pedal should lock in the down position, and the tractor will maintain the same forward speed.
- Disengage the cruise control using one of the following methods:
 - Depress the brake pedal to disengage the cruise control and stop the tractor.
 - Lightly depress the forward control pedal.

NOTE: Although not recommended, depressing the reverse pedal will also disengage the cruise control.

To change to the reverse direction when operating with cruise control, depress the brake pedal to disengage the cruise control and stop the tractor; then depress the reverse control pedal.

Driving On Slopes

Refer to the SLOPE GAUGE on page 8 to help determine slopes where you may not operate safely.



WARNING: Do not mow on inclines with a slope in excess of 15 degrees (a rise of approximately 2-1/2 feet every 10 feet). The tractor could overturn and cause serious injury.

Operate the tractor up and down slopes, never across slopes. Do not drive so that the tractor may tip over sideways

Before operating the tractor on a slope, walk the slope to look for possible hazards such as rocks, mounds, stumps, or surface irregularities which could cause the tractor to be upset.

Back the tractor with attachment up the steepest portion of each slope you intend to work. If the tractor cannot negotiate the slope in reverse, the slope is too steep to be worked.

Avoid turns when driving on a slope. If a turn must be made, turn down the slope. Turning up a slope greatly increases the chance of a roll over.

Avoid stopping when driving up a slope. If it is necessary to stop while driving up a slope, start up smoothly and carefully to reduce the possibility of flipping the tractor over backward.

Stopping The Tractor

Fully depress the brake pedal to bring the tractor to a complete stop, engage the parking brake, disengage the PTO, turn the ignition switch to "STOP" and remove the key from the switch before dismounting.

Using the Hydraulic Lift System

To raise an attachment using the hydraulic lift system, the engine must be running. Generally, an attachment can be lowered with the engine running or off. Push the hydraulic lift lever forward to lower an attachment or pull the hydraulic lift lever back to raise an attachment.

Auxiliary Hydraulics

The tractor auxiliary hydraulic circuit consists of two hydraulic outlets with male and female quick connect couplers. The outlets are located beneath the front of the left running board, and are normally used for connecting the optional Hydraulic Front Hitch Kit.

The auxiliary hydraulic lever on the left fender controls the oil flow through the auxiliary hydraulic circuit. The engine must be running to utilize the auxiliary hydraulic system. The lever is normally used to raise and lower the front hitch. If correctly installed, pushing the lever forward (downward) will lower the front hitch and pulling the lever rearward (upward) will raise it.

Always refer to the manual of the specific attachment for the correct connection and operating instructions.

Opening Tool Box

A tool box and manual pouch is located under the seat. To access this area, pivot the seat forward.

Engaging The PTO

- Move throttle control lever to approximately the mid throttle position.
- Pull the PTO switch to the "RUN" position.
- Advance the throttle lever to the operating speed (full engine speed).
- The operator must remain in the tractor seat at all times. If the operator should leave the seat without turning off the PTO switch, the tractor's engine will shut off.
- **With key switch in "NORMAL MOWING" position ONLY:** The PTO clutch cannot be operated when the tractor is driven in the reverse direction. In the "NORMAL MOWING" position, the PTO clutch will automatically disengage when the reverse pedal is depressed. To re-engage the PTO clutch, release the reverse control pedal, move the PTO switch to the "OFF" position, then again pull the switch to the "RUN" position.

Using the REVERSE CAUTION MODE key position

The **REVERSE CAUTION MODE** position of the key switch module allows the machine to be operated in reverse with the blades (PTO) engaged.

IMPORTANT: *Mowing in reverse is not recommended.*



Use extreme caution while operating the tractor in the "Reverse Caution Mode". Always look down and behind before and while backing. Do not operate the tractor when children or others are around. Stop the tractor immediately if someone enters the area.

To use the **REVERSE CAUTION MODE**, proceed as follows:

IMPORTANT: *The operator MUST be seated in the tractor seat.*

1. Start the engine as previously instructed in this Operator's Manual.
2. Turn the key from the **NORMAL MOWING** (Green) position to the **REVERSE CAUTION MODE**

(Yellow) position of the key switch module. Refer to Figure 10.

3. Depress the **REVERSE PUSH BUTTON** (Orange/Triangular Button) at the top/right corner of the key switch module. The red indicator light at the top/left corner of the key switch module will be "ON" while activated. Refer to Figure 10.
4. Once activated (indicator light "ON"), the tractor can be driven in reverse with the cutting blades (PTO) engaged.
5. Always look down and behind before and while backing to make sure no children are around.
6. After resuming forward motion, return the key to the **NORMAL MOWING** position.

IMPORTANT: *The REVERSE CAUTION MODE will remain activated until:*

- *The key switch is turned to either the **NORMAL MOWING** or **STOP** position.*
- *The operator leaves the seat. Follow the previous instructions to re-activate.*

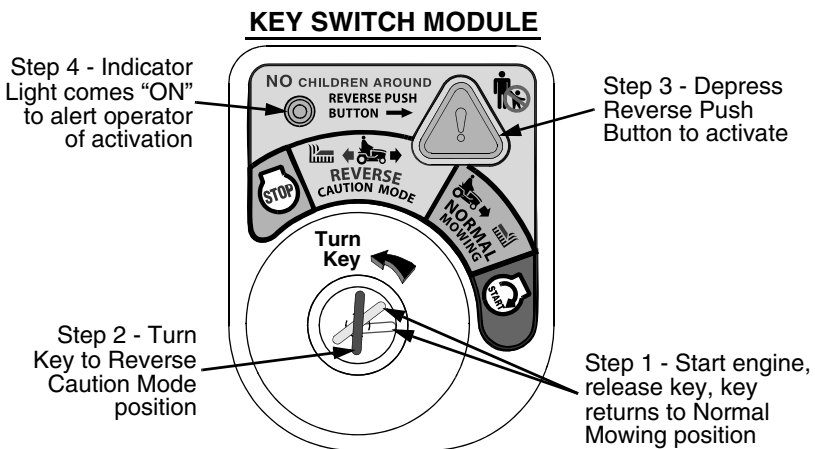

Figure 10

Engaging Differential Lock

Fully depress the diff. lock pedal to lock the transmission differential and provide constant power to both rear wheels when increased traction is needed. Release the diff. lock pedal when extra traction is not needed.

Depressing the brake pedal also actuates the diff. lock pedal, resulting in optimal braking action.

NOTE: *Because of the load on the internal engagement mechanism, releasing the diff. lock pedal may not always disengage the differential lock. It may be necessary to slow the tractor, or reverse the direction of travel, to disengage the differential lock.*

Using The Drawbar

Drawbar equipment must be hitched to the tractor only at the hitch hole. See Figure 11.

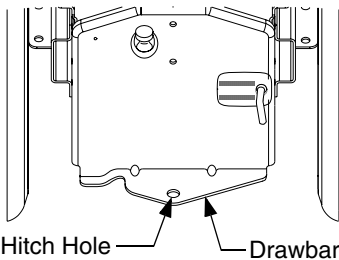

Figure 11

Mowing



WARNING: To avoid possible injury, never direct the discharge of material toward bystanders or allow anyone near the machine while in operation. Although the area has been supposedly cleared of foreign objects, small objects may be picked up and discharged by the mower.

IMPORTANT: *Do not engage the mower deck when lowered in grass. Premature wear and possible failure of the "V" belts and PTO clutch will result. Fully raise the deck or move to a non grassy area before engaging the mower deck.*

This tractor can be equipped with one of Cub Cadet's high quality mowing decks. The following information will be helpful when using a Cub Cadet mowing deck with your tractor.

For best results it is recommended that the first two laps be cut with the discharge thrown towards the center. After the first two laps, reverse the direction to throw the discharge to the outside for the balance of cutting. This will give a better appearance to the lawn.

Do not cut the grass too short, as the mower will tend to scalp the grass. Short grass invites weed growth and yellows quickly in dry weather.

Mowing should be done with the engine at full throttle. Do not mow at high ground speed.

During certain times of the year and under some conditions, the mower may leave streaks of uncut grass.

Streaking may occur when attempting to mow heavy weeds and tall grass. Under these conditions it may be necessary to go back over the cut area a second time to get a clean cut.

The following practices will help eliminate streaking:

- Mow the area more often so the grass doesn't get too tall and heavy.
- Operate the tractor at full throttle and slower forward speeds.
- Keep the blades sharp and replace the blades when worn.

SECTION 6: ADJUSTMENTS and MAINTENANCE

Seat Adjustment



WARNING: Do not adjust the seat when the tractor is moving, as this could cause the operator to lose control of the tractor.

For the comfort of the operator, the tractor is equipped with an easy to operate adjustable seat. There are also three seat mounting positions to provide additional adjustment.

To adjust the seat forward or back, slide the seat adjustment lever to the left; reposition the seat to your most comfortable position; and release the seat adjustment lever. See Figure 12.

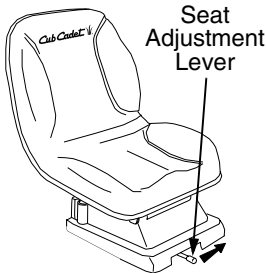

Figure 12

If additional adjustment is desired, flip the seat forward, remove the four screws fastening the seat, and re-mount the seat on the hinge brackets as follows (See Figure 13):

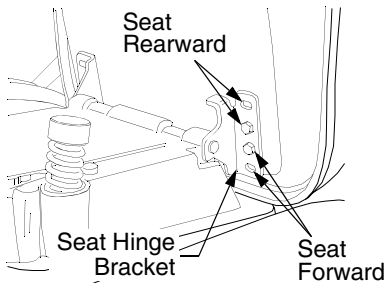

Figure 13

- Seat forward-use front two holes.
- Seat middle-use middle two holes.
- Seat rearward-use rear two holes

Brake Inspection and Adjustment

During normal operation, the tractor brake is subject to minimal wear. However, the brake should be periodically tested, and adjusted if necessary.

Checking the Brake.

Place the tractor on a firm and level surface. Stop the engine and remove the ignition key.

Pull and lock the transmission release rod in the "Transmission Released" position. Perform the following checks: *NOTE: The tractor may be difficult to push because of the hydro transmission's braking action.*

- Engage the parking brake. If the tractor can be pushed forward or rearward, the braking force must be increased.
- Release the Parking Brake Lever. If the tractor cannot be pushed forward or rearward, the braking force must be decreased.

Turning Radius Adjustment

This tractor is equipped with hydraulic power steering which is set at the factory. The turning radius should be equal for both left and right hand turns. If adjustment is necessary please contact your authorized Cub Cadet dealer.

Accessing Engine Compartment

The engine compartment can be accessed by raising the hood as follows:

- Lift the hood straight upward at the recessed notches of the side panels to disengage the internal hood latch.
- Carefully pivot the hood forward to open.

To close the hood:

- Carefully pivot the hood rearward to lower.
- Push down on the front of the hood to engage the internal hood latch.

If greater access is required, the tractor is equipped with quick release side panels. Remove the quick release side panels as follows (See Figure 16):

- Open the hood by lifting upward at the side panel notches on each side of the tractor.
- Flip the tab of the two quick release fasteners up and turn to align with the slots in side panels.
- Swing the rear of the side panel out and away from the tractor.
- Slide the side panel rearward to disengage the two front tabs of the

side panel from the slots of the grille/side panel mounting strip.

To reinstall the side panels:

- Insert the side panel front tabs into the slots of the grille/side panel mounting strip.
- Swing the rear of the side panel inward and align so that the tabs of the quick release fasteners go through the side panel slots.
- Pull the quick release fastener tabs slightly outward and rotate 1/4 turn (perpendicular to slot) to lock the side panels in place. Flip the fastener tabs down and close hood.

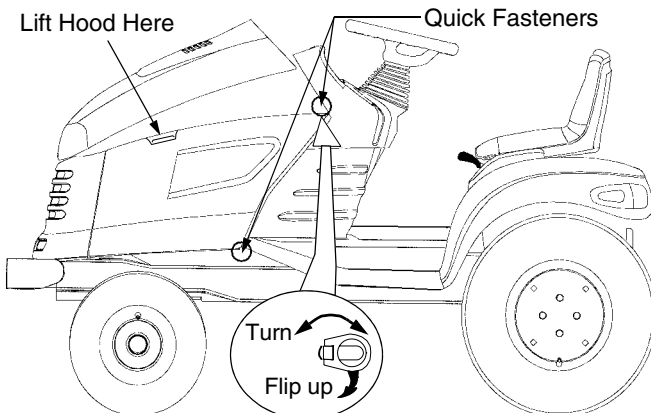

Figure 14

Checking Transmission Oil Level

NOTE: Check the oil level only while the engine is stopped and the tractor is level.

Check the oil level of the transmission case before each use to see that it is filled to the correct level. Before checking the transmission oil level, clean the area around the Transmission Oil Fill/Dipstick to prevent debris from entering the transmission case. Always keep the oil level between the "FULL" and the "ADD" marks on the dipstick. When checking the oil level, the dipstick must be withdrawn and wiped clean,

then fully reinserted before being withdrawn again for a true reading.

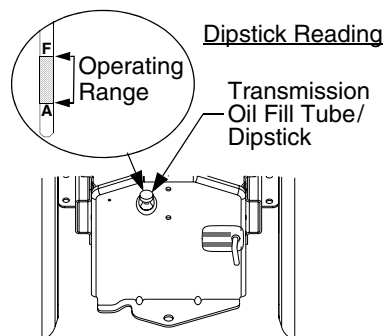

Figure 15

Tire Inflation

Keep the tires inflated to the recommended pressure. Improper inflation will affect tire life and operator comfort, and also could affect the level of the mower deck and quality of cut. See the tire side wall for proper inflation range.

Ensure that the valve caps are securely tightened in place to prevent air loss and to protect the valve core.

Do not overload the tractor tires by mounting equipment on the tractor which exceeds the load capacity of the size of the tires on the tractor.

Battery Maintenance

The battery is filled with battery acid and then sealed at the factory. However, even a "maintenance free" battery requires some maintenance to ensure its proper life cycle.

- Spray the terminals and exposed wire with a battery terminal sealer, or coat the terminals with a thin coat of grease or petroleum jelly, to protect against corrosion.
- Always keep the cables and terminals clean and free of corrosion.
- Always keep the terminal covers in place over the battery terminals.
- Avoid tipping. Even a sealed battery will leak electrolyte when tipped.

Battery Storage

- When storing the tractor for extended periods, disconnect the negative battery cable. It is not necessary to remove the battery.
- All batteries discharge during storage. Keep the exterior of the battery clean, especially the top. A dirty battery will discharge more rapidly.
- The battery must be stored with a full charge. A discharged battery can freeze sooner than a charged

battery. A fully charged battery will store longer in cold temperatures than hot.

- Recharge the battery before returning to service. Although the tractor may start, the engine charging system may not fully recharge the battery.

Lubrication

Important Information: The service life and reliability of any machine depends upon the care it is given. Proper lubrication is a very important part of that care. The maintenance schedule reflects the minimal requirements to maintain the equipment. More frequent inspections and maintenance is preferable.

Using the lubrication illustration as a guide, make certain that all lubrication fittings are installed and functioning.

Be sure all fittings are free from dirt and paint so the lubricant is certain to enter the bearing.

Using a pressure lubricating gun, always force the lubricant through the full length of each bearing until it emerges at the end, carrying with it the worn lubricant and any dirt that may have entered the bearing.

Miscellaneous working parts not provided with lubrication fittings should be oiled regularly with a good grade of lubricating oil.

Always lubricate the tractor thoroughly before taking it to a remote location for a prolonged period of time.

Lubricant is cheap. Use plenty of it. Worn parts can be expensive to replace.

Keep your supply of lubricating oil and grease stored in clean containers, and covered to protect from dust and dirt.

Keep the lubricating gun nozzle clean and wipe dirt from the grease fittings before lubricating.

Maintenance Chart

Operation to be performed	Each Use	10 Hours	50 Hours	100 Hours	150 Hours	200 Hours	250 Hours	300 Hours
Grease front wheel bearings		•						
Grease L/R steering knuckles		•						
Grease front pivot axle		•						
Check engine oil level	•							
Change engine oil and filter				•		•		•
Check spark plug condition				•		•		•
Check transmission oil level	•							
Change transmission oil filter				•	•	•	•	•
Change transmission oil					•		•	
Check air cleaner & housing	•							
Clean & re-oil foam air pre-cleaner	††							
Change air cleaner paper cartridge				†		†		†

† More often under dusty conditions

†† Clean every 25 hours or more often under dusty or dirty conditions

NOTE: With the exception of utilizing the deck wash feature on the mower deck, we do not recommend the use of a pressure washer or garden hose to clean your tractor. Water may cause damage to electrical components; spindles; pulleys; bearings; or the engine.

Lubrication Illustration



Cub Cadet 251H EP Grease or equivalent No. 2 lithium grease



Engine Oil: See Figure 27 on page 34
Transmission Oil - Cub Cadet Drive System Fluid Plus - **ONLY**



Oil Can (High quality lubricating oil)

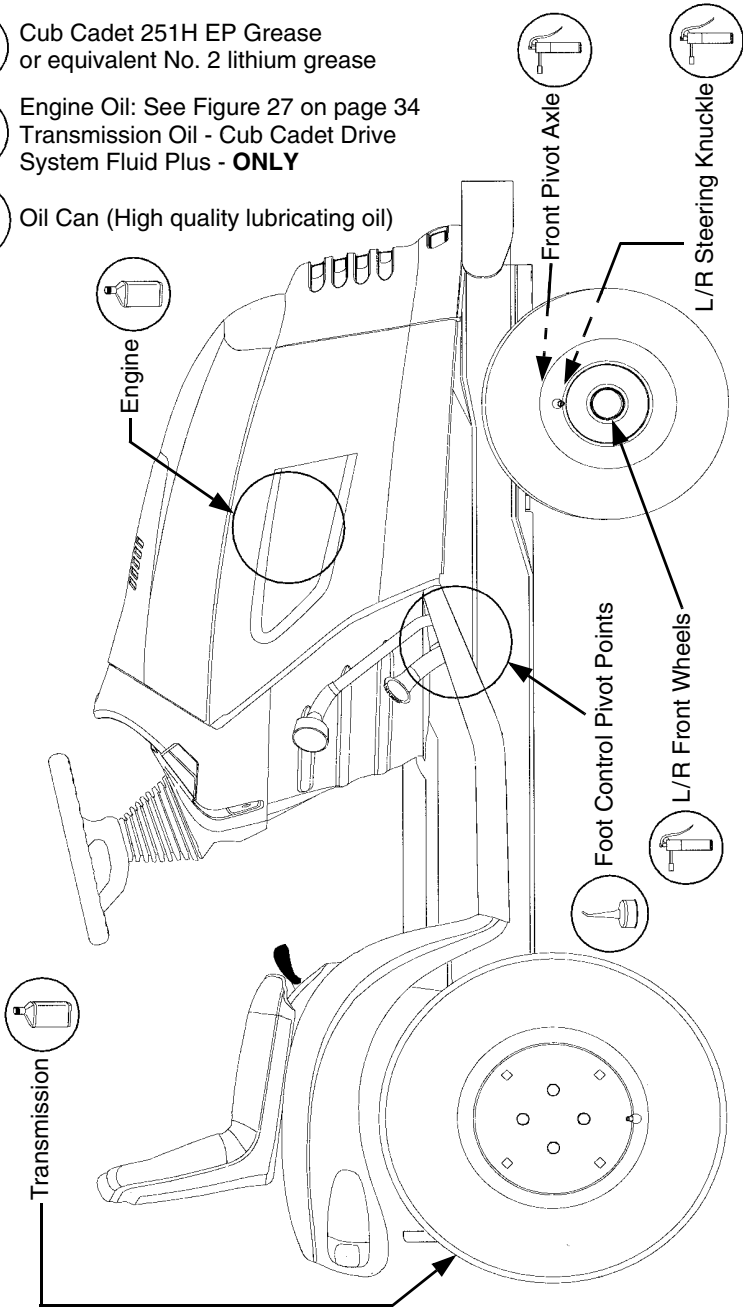

Figure 16

SECTION 7: SERVICE

General Battery Information



WARNING

- Battery posts, terminals and related accessories contain lead and lead compounds. Wash hands after handling.
- Should battery acid accidentally splatter into the eyes or onto the skin, rinse the affected area immediately with clean cold water. If there is any further discomfort, seek prompt medical attention.
- If acid spills on clothing, first dilute it with clean water, then neutralize with a solution of ammonia/water or baking soda/water.
- NEVER connect (or disconnect) battery charger clips to the battery while the charger is turned on, as it can cause sparks.
- Keep all sources of ignition (cigarettes, matches, lighters) away from the battery. The hydrogen gas generated during charging can be combustible.
- As a further precaution, only charge the battery in a well ventilated area.
- Always shield eyes and protect skin and clothing when working near batteries.



WARNING: Batteries contain sulfuric acid and may emit explosive gases. Use extreme caution when handling batteries. Keep batteries out of the reach of children.

Battery Removal



WARNING: Battery posts, terminals and related accessories contain lead and lead compounds. Wash hands after handling.

The battery is located under the dash panel in the frame pedestal.

To remove the battery:

- Open the tractor hood by lifting it at the notches in the side panels.
- Remove the upper bulkhead baffle from the front of the dash panel by lifting upward on the baffle locking tab on each side.
- Pull the upper end of the rubber battery strap rearward to unhook it from the tab on the pedestal.
- Loosen the negative battery cable clamp, disconnect the negative cable, and move the cable away from the battery. Disconnect the positive lead from the battery in the same manner.
- Carefully lift the battery up and out of the tractor.

Install the battery by repeating the above steps in the reverse order.

IMPORTANT: *Always connect the positive lead to the battery before connecting the negative lead.*

Charging the Battery

Test and, if necessary, recharge the battery after the tractor has been stored for a period of time.

- A voltmeter or load tester should read 12.6 volts (DC) or higher across the battery terminals.
- Charge the battery with a 12-volt battery charger at a **MAXIMUM** rate of 10 amps.

Voltmeter Reading	State of Charge	Charging Time
12.7	100%	Full Charge
12.4	75%	90 Min.
12.2	50%	180 Min.
12.0	25%	280 Min.

Headlight Bulb Replacement

Replace headlight bulbs as follows:
(See Figure 17)

1. After noting which wire connects to each terminal, unplug the wire harness leads from the headlight socket terminals.
2. Rotate the socket assembly as follows to remove from the reflector housing:

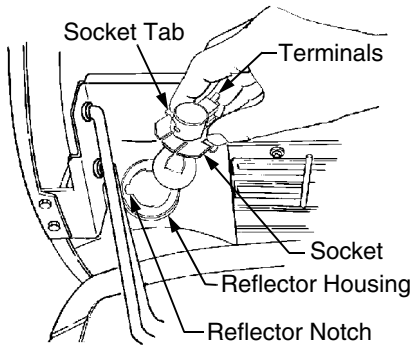

Figure 17

- Left headlight — approximately 1/4 turn counterclockwise.
 - Right headlight — approximately 1/4 turn clockwise.
3. Push the bulb inward and turn counterclockwise to remove from the socket.
 4. Align the post of the bulb base with the notch in the socket, then push the bulb inward and turn clockwise to lock
 5. With the terminals pointing upward, align the tab of the socket with the notch of the reflector. Push the socket inward and turn as follows to lock:
 - Left headlight-1/4 turn clockwise.
 - Right headlight-1/4 turn counterclockwise.
 6. Connect the wire harness leads to the appropriate socket terminals.

Adding Transmission Oil



WARNING: The fluid for your transmission has been specially formulated to ensure the safe and proper operation of your tractor. Add Cub Cadet Drive System Fluid Plus ONLY. Do not use any other fluid.



WARNING: Never overfill the transmission case. Damage may result if the oil level in the transmission case is below the “ADD” mark or over the “FULL” mark of the dipstick.

For best results, fill to the “FULL” mark on the dipstick as opposed to adding a given quantity of oil. Always check the level on the dipstick before adding more oil. Refer to Figure 15.

Refer to the Lubrication Illustration for information regarding the proper type of oil to add to the transmission case. See the Specifications Chart for the quantity required.

- Place the tractor on a level surface and engage the parking brake. Stop the engine and remove the ignition key.
- Clean the area around the Transmission Oil Fill/Dipstick to prevent debris from entering the transmission case.
- Remove the dipstick from the oil fill tube and SLOWLY pour oil into the oil fill tube. Fill the transmission case until the oil level reaches the “FULL” mark on the dipstick.
- Reinstall the dipstick securely into the oil fill tube.



WARNING: The oil fill plug/dipstick must be installed securely into the fill tube at all times when the engine is operating.

Changing Transmission Oil



WARNING: The fluid for your transmission has been specially formulated to ensure the safe and proper operation of your tractor. When changing the transmission fluid replace it with Cub Cadet Drive System Fluid Plus ONLY. Failure to use Cub Cadet Drive System Fluid Plus may result in a failure of the drive system which could result in property damage or personal injury. Do not use any other fluid

See to the Maintenance Chart for the frequency of service and the Specifications Chart for the quantity required.

NOTE: Do not reuse the transmission oil. Contaminated transmission oil can damage the hydro transmission.



Please dispose of used oil at appropriate recycling centers.

- Place the tractor on a level surface and engage the parking brake. Stop the tractor's engine and remove the ignition key.
- Remove any center attachments.
- Clean the area around the transmission drain plug to prevent debris from entering the transmission case. Remove the drain plug and allow the transmission oil to drain into a clean container having a capacity of more than 5 quarts. Reinstall the drain plug. Refer to Figure 18.

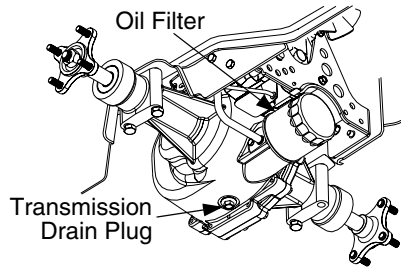

Figure 18

- Clean around the base of the transmission oil filter and remove the filter by turning it counterclockwise.
- Apply a light coating of clean transmission oil to the gasket of the new filter. Install the filter by turning it clockwise, by hand, until the gasket contacts the filter base on the transmission housing; then tighten the filter an additional 1/2 turn.
- Clean the area around the Transmission Oil Fill/Dipstick to prevent debris from entering the transmission case.
- Remove the dipstick and slowly pour oil into the oil fill tube. Fill the transmission case until the oil level reaches the "Full" mark on dipstick.
- Reinstall the dipstick securely into the oil fill tube.
- Start the engine and allow it to run for a few minutes. Shut the engine off, then check for leaks and recheck the oil level in the transmission case.

Electrical Box

The electrical box contains the relay and fuses. Refer to Figure 19 for the electrical box layout. The electrical box is located under the upper air baffle in front of the dash panel. To access the electrical box:

- Raise the hood of the tractor
- Locate the locking tabs on the left and right side of the upper air baffle.
- Pull up on the locking tabs on each side of the upper air baffle, and remove the upper air baffle from the lower air baffle. Lift the upper air baffle from the tractor.
- Lift the locking tab and remove the cover from the electrical box.

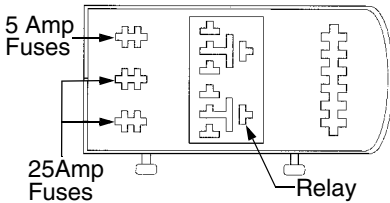

Figure 19

Fuse

Fuses are installed to protect the tractor's electrical system from damage caused by excessive amperage.

Always use the same capacity fuse for replacement. Refer to the Specifications Chart. If the electrical system does not function, check the fuses.

To replace a fuse, note the position of the fuse and pull the old fuse from the electrical box.

Compare the suspect fuse with Figure 20 to determine if is good or bad.

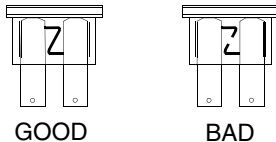

Figure 20

Install the new fuse in the position from which the old fuse was removed.

Front Wheel Alignment

Note: The left-hand ball joint is left-hand threaded.

The front wheels should toe-in approximately 1/8 inch. Measure distances A and B. A should be approximately 1/8 inch less than B. See Figure 21.

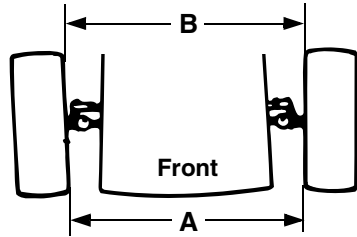

Figure 21

To adjust toe-in, loosen left and right ball joint jam nuts. Refer to Figure 22.

Turn the tie rod in or out of the ball joints as required to attain proper adjustment. Tighten the jam nuts against the ball joints.

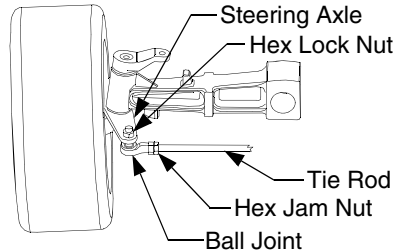

Figure 22

Adjusting the Brake.

Remove the rear drawbar from the frame by removing the four hex tapp screws. **NOTE:** The oil fill tube/dipstick will be pulled from the transmission housing. Plug or cover the hole in the transmission to prevent dirt or debris from entering.

From beneath the right/rear side of the tractor frame, secure the hex shaped flange of the brake rod (located just behind the brake link) to prevent the rod from turning (Refer to Figure 23).

From just above the *right* axle carrier, inside the *right* frame rail, slowly turn the hex nylon lock nut at the end of the brake rod as follows to adjust the brake (Refer to Figure 23):

- Turn the nylon lock nut clockwise to increase the braking force.
- Turn the nylon lock nut counter-clockwise to decrease the braking force.

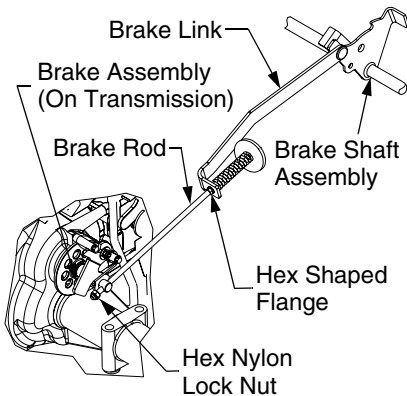

VIEWED FROM ABOVE - FENDER AND RUNNING BOARD REMOVED

Figure 23

Recheck the brake adjustment to ensure proper operation, and readjust as necessary. If brake adjustment does not correct the problem, see your authorized *Cub Cadet* dealer.

While guiding the transmission release rod through keyhole and the oil fill tube/dipstick into the transmission, reinstall the rear drawbar on the frame. Secure with the four hex tapp screws.

Changing the Engine Oil and Filter



Warning! If the engine has been recently run, the engine, muffler and surrounding metal surfaces will be hot and can cause burns to the skin. Exercise caution to avoid burns.

The oil filter should be changed at every oil change interval. The filters can be obtained through your *Cub Cadet* dealer. Refer the engine operator's manual, or the condensed engine information in the next section of this manual, for information regarding the frequency of required oil changes and the quantity of oil needed. To drain the engine oil, proceed as follows:

- Run the engine for a short time to warm the engine oil. The oil will flow more freely and carry away more impurities. Use care to avoid burns from hot oil.
- Locate the oil drain port and filter on the left side of the engine.
- Pop open the protective cap on the end of the oil drain valve to expose the drain port. See Figure 24. Remove the dipstick from its tube.

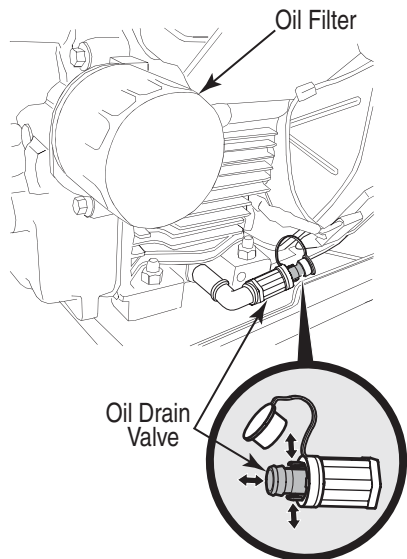

Figure 24

- Push the oil drain hose (packed with this manual) onto the oil drain port. Route the opposite end of the hose into an appropriate oil collection container with at least a 2.5 quart capacity, to collect the used oil.

- Pinch in the lock tabs on the oil drain valve, then pull the drain port outward to begin draining oil. Refer to Figure 24.
 - After the oil has finished draining, push the end of the oil drain valve back in, until the tabs click into place. Re-cap the end of the oil drain valve to keep debris from entering the drain port.
 - Replace the oil filter, and refill the engine with new oil as instructed in the Kohler Owner's Manual.
2. If emptying the fuel system:
 - Fill the fuel tank with treated fuel and run the engine for 2-3 minutes to get stabilized fuel into the carburetor.
 - Near end of the season, monitor fuel consumption with the goal of running the fuel tank to empty.
 - If a large volume of fuel is left over, remove the fuel cap and siphon the bulk of any leftover fuel into an approved container.
 - Run the engine until it starts to falter, then use the choke to keep the engine running until all fuel in the carburetor has been exhausted.

Off-Season Storage

If the machine is to be inoperative for a period longer than 30 days, the following procedures are recommended:



WARNING: Never store the tractor with fuel in the tank, indoors or in poorly ventilated enclosures where fuel fumes may reach an open flame, spark or pilot light (e.g.: furnace, water heater, clothes dryer, etc.).



WARNING: Fuel left in the fuel tank deteriorates and will cause serious starting problems.

To prevent gum deposits from forming inside the engine's carburetor and causing possible malfunction of the engine, the fuel system must be either completely emptied, or the gasoline must be treated with a stabilizer to prevent deterioration.

1. If using a fuel stabilizer:
 - Read the product manufacturer's instructions and recommendations.
 - Add to clean, fresh gasoline the correct amount of stabilizer for the capacity of the fuel system.

3. Perform the following procedures before storing the machine.
 - Remove the spark plugs and pour one (1) ounce of engine oil through the spark plug holes into the cylinders. Install the spark plugs but do not connect the plug wires. Crank the engine two or three revolutions to distribute the oil.
 - Clean the engine and the entire tractor thoroughly.
 - Lubricate all lubrication points.
 - Prepare the battery for storage.
 - Protect the tires and seat from sunlight. Regularly check the tires for proper inflation.

NOTE: *With the exception of utilizing the deck wash feature on the mower decks, we do not recommend the use of a pressure washer or garden hose to clean your tractor. Water may cause damage to electrical components; pulleys; bearings; or the engine.*

SECTION 8: ENGINE INFORMATION

KOHLER CO. FEDERAL AND CALIFORNIA EMISSION CONTROL SYSTEMS LIMITED WARRANTY SMALL OFF-ROAD EQUIPMENT ENGINES

The U.S. Environmental Protection Agency (EPA), the California Air Resources Board (CARB), and Kohler Co. are pleased to explain the Federal and California Emission Control Systems Warranty on your off-road equipment engine. For California, small off-road engines produced in 1995 and later must be designed, built and equipped to meet the state's stringent anti-smog standards. In other states, 1997 and later model year engines must be designed, built and equipped, to meet the U.S. EPA regulations for small non-road engines. The engine must be free from defects in materials and workmanship which cause it to fail to conform with U.S. EPA standards for the first two years of engine use from the date of sale to the ultimate purchaser. Kohler Co. must warrant the emission control system on the engine for the period of time listed above, provided there has been no abuse, neglect or improper maintenance.

The emission control system may include parts such as the carburetor or fuel injection system, the ignition system, and catalytic converter. Also included are the hoses, belts and connectors and other emission related assemblies.

Where a warrantable condition exists, Kohler Co. will repair the engine at no cost, including diagnosis (if the diagnostic work is performed at an authorized dealer), parts and labor.

MANUFACTURER'S WARRANTY COVERAGE

Small off-road engines produced in 1995 or later are warranted for two years in California. In other states, 1997 and later model year engines are warranted for two years. If any emission related part on the engine is defective, the part will be repaired or replaced by Kohler Co. free of charge.

OWNER'S WARRANTY RESPONSIBILITIES

- (a) The engine owner is responsible for the performance of the required maintenance listed in the owner's manual. Kohler Co. recommends that you retain all receipts covering maintenance on the engine. But Kohler Co. cannot deny warranty solely for the lack of receipts or for your failure to assure that all scheduled maintenance was performed.
- (b) Be aware, however, that Kohler Co. may deny warranty coverage if the engine or a part has failed due to abuse, neglect, improper maintenance or unapproved modifications.
- (c) For warranty repairs, the engine must be presented to a Kohler Co. service center as soon as a problem exists. Call 1-800-544-2444, or access our web site at: www.kohlerengines.com, for the names of the nearest service centers. The warranty repairs should be completed in a reasonable amount of time, not to exceed 30 days.

If you have any questions regarding warranty rights and responsibilities, you should contact Kohler Co. at 1-920-457-4441 and ask for an Engine Service representative.

COVERAGE

Kohler Co. warrants to the ultimate purchaser and each subsequent purchaser that the engine will be designed, built and equipped, at the same time of sale, to meet all applicable regulations. Kohler Co. also warrants to the initial purchaser and each subsequent purchaser, that the engine is free from defects in material and workmanship which cause the engine to fail to conform with applicable regulations for a period of two years.

Small off-road engines produced in 1995 or later are warranted for two years in California. For 1997 and later model years, EPA requires manufacturers to warrant engines for two years in all other states. These warranty periods will begin on the date the engine is purchased by the initial purchaser. If any emission related part on the engine is defective, Kohler Co. will replace the part at no cost to the owner. Kohler Co. is liable for damages to other engine components caused by the failure of a warranted part still under warranty.

Kohler Co. shall remedy warranty defects at any authorized Kohler Co. engine dealer or warranty station. Warranty repair work done at an authorized dealer or warranty station shall be free of charge to the owner if such work determines that a warranted part is defective.

Listed below are the parts covered by the Federal and California Emission Control Systems Warranty. Some parts listed below may require scheduled maintenance and are warranted up to the first scheduled replacement point for that part. The warranted parts are:

- Oxygen sensors (if equipped)
- Intake Manifold (if equipped)
- Exhaust Manifold (if equipped)
- Catalytic muffler (if equipped)
- Fuel metering valve (if equipped)
- Spark advance module (if equipped)
- Ignition module(s) with high tension lead
- Gaseous fuel regulator (if equipped)
- Electronic control unit (if equipped)
- Carburetor or fuel injection system
- Fuel lines (if equipped)
- Air filter, fuel filter, and spark plugs (only to first scheduled replacement point equipped)

LIMITATIONS

This Emission Control System Warranty shall not cover any of the following:

- (a) repair or replacement required because of misuse or neglect, improper maintenance, repairs improperly performed or replacement not conforming to Kohler Co. specifications that adversely affect performance and/or durability, and alterations or modifications not recommended or approved in writing by Kohler Co.,
- (b) replacement of parts and other services and adjustments necessary for required maintenance at and after the first scheduled replacement point,
- (c) consequential damages such as loss of time, inconvenience, loss of use of the engine or equipment, etc.,
- (d) diagnosis and inspection fees that do not result in eligible warranty service being performed, and
- (e) any add-on or modified part, or malfunction of authorized parts due to the use of add-on or modified parts.

MAINTENANCE AND REPAIRS REQUIREMENTS

The owner is responsible for the proper use and maintenance of the engine. Kohler Co. recommends that all receipts and records covering the performance of regular maintenance be retained in case questions arise. If the engine is resold during the warranty period, the maintenance records should be transferred to each subsequent owner. Kohler Co. reserves the right to deny warranty coverage if the engine has not been properly maintained; however, Kohler Co. may not deny warranty repairs solely because of the lack of repair maintenance or failure to keep maintenance records.

Normal maintenance, replacement or repair of emission control devices and systems may be performed by any repair establishment or individual; however, **warranty repair must be performed by a Kohler authorized service center**. Any replacement part or service that is equivalent in performance and durability may be used in non-warranty maintenance or repairs, and shall not reduce the warranty obligations of the engine manufacturer.

Cleaning The Engine

This tractor has an air-cooled engine. Air must be able to circulate freely around the engine through the fly-wheel screen, through the cooling shrouds and over the fins of the cylinder head and cylinder block. Keep these areas free of accumulated dirt and debris or the engine will overheat; possibly causing extensive engine damage. Regularly clean the inside of the side panels, dash intake screen and grille to ensure adequate cooling. If debris has accumulated inside the cooling shrouds, the blower housing and cooling shrouds should be removed and the cooling fins cleaned.



WARNING: This machine is designed to cool properly with the side panels in place. Operating without the panels could cause premature accumulation of dirt and debris on the engine, resulting in inadequate cooling.



WARNING: Keep the muffler area clean. Before running the engine, clean the muffler area to remove all combustible debris. Inspect the muffler area often when mowing during the Fall season.

Checking Engine Oil Level

Before each use, the oil level of the engine crankcase to see that it is filled to the correct level. Close monitoring of the oil level during the first 10 hours of operation of the engine is especially important and the oil level should be checked **EVERY HOUR** during the first five hours of operation.

Before checking the oil level, clean the area around the oil level dipstick to prevent debris from entering the crankcase. Refer to Figure 26. Always keep the oil level between the “FULL” and the “ADD” marks on the dipstick. See Figure 25.

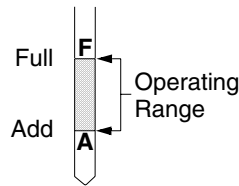

Figure 25

When checking the oil level, the engine must be cold, the dipstick must be withdrawn and wiped clean, then inserted all the way into the tube before being withdrawn for a true reading.

Check the oil level only while the engine is stopped and the tractor is level.

Adding Engine Oil



WARNING: Never overfill the crankcase. The engine may overheat and/or damage may result if the crankcase is below the “ADD” mark or over the “FULL” mark on the dipstick. For best results, fill to the “FULL” mark on the dipstick as opposed to adding a given quantity of oil. Always check the level on the dipstick before adding more oil.

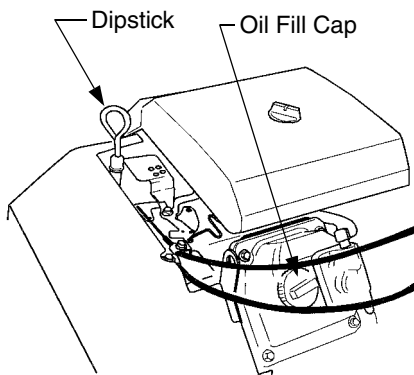

Figure 26

Refer to Figure 27 for information regarding the proper type of oil to add to the crankcase.

- Place the tractor on a level surface and engage the parking brake. Stop the tractor engine and remove the ignition key.
- Clean the area around the oil filler cap to prevent debris from entering the crankcase. Refer to Figure 26.
- Remove the oil filler cap from the left valve cover and SLOWLY pour in oil. Fill the crankcase until the oil level reaches the "FULL" mark on the dipstick. Refer to Figure 25.
- Reinstall the oil filler cap and turn to the right to tighten securely in the valve cover.



WARNING: The oil filler cap must be tightened securely into the valve cover at all times when the engine is operating. Severe engine damage could result from failure to do so.

Changing Engine Oil



WARNING: If the tractor has recently been operated, the engine and surrounding areas may be hot. Use caution not to burn yourself when working around the engine.

See Replacement Parts for the correct oil filter part number. Refer to the below viscosity chart for the proper type of oil to use.

Above +32° F	SAE 10W30
Below +32° F	SAE 5W20 SAE 5W30

Figure 27

NOTE: A length of flexible tubing is supplied with the tractor and should be used to drain the engine oil.

- Place the tractor on a level surface and engage the parking brake. Stop the tractor engine and remove the ignition key.
- Clean around the base of the oil filter, the oil filler cap, and the dipstick tube to prevent debris from entering the crankcase. See Figure 24 and Figure 26.
- Refer to Changing the Engine Oil and Filter on pages 29-30 for instructions on draining the engine oil.
- Remove the filter by turning it counterclockwise using an automotive type filter wrench to loosen.
- Allow the old oil to completely drain from the engine crankcase into the container below. Close the drain valve.

- Remove the flexible tubing from the drain valve. Clean the tubing and store in a safe place for future use.
- Clean the drain valve and push the plastic dust cap onto the valve.
- Turn the replacement filter open end up and pour new oil into the filter through the threaded center hole. Fill to the bottom of the threads, then wait a minute or two to allow the oil to be absorbed into the filter material.
- Apply a light coating of clean oil on the gasket of the new oil filter. Thread the filter on by hand until the gasket contacts the oil filter adapter, then tighten the oil filter an additional **2/3 to 1** turn.
- Refill the crankcase with the appropriate quantity and type of oil.
- Check oil level and make sure that oil filler cap, dipstick and drain valve are in place and closed.

Sparkplugs



WARNING: To avoid possible injury, be sure the engine is off and has cooled before making any adjustments or repairs.

Remove all dirt from around the spark plug before removing.

Use a spark plug wrench to remove the spark plugs.

Check the gap after every 100 hours of operation.

Replace a defective plug with a new plug. Set the spark plug gap at .030 inch. Tighten the plug to 18-22 ft-lbs. See your authorized dealer for the correct replacement plug.

Changing Fuel Filter



WARNING: Do not replace fuel filter when engine is hot.

The engine is equipped with an in-line fuel filter. Visually inspect the filter periodically for a build-up of residue inside the filter body, and for a dirty element which can be indicated by discoloration. Replace the fuel filter when dirty.

Changing Air Cleaner

Check the air cleaner daily or before starting the engine. Check for loose or damaged components and check the condition of the filter element. Remove any buildup of dirt and debris in the air cleaner housing.

See Figure 28 for assembly of the Air cleaner elements.

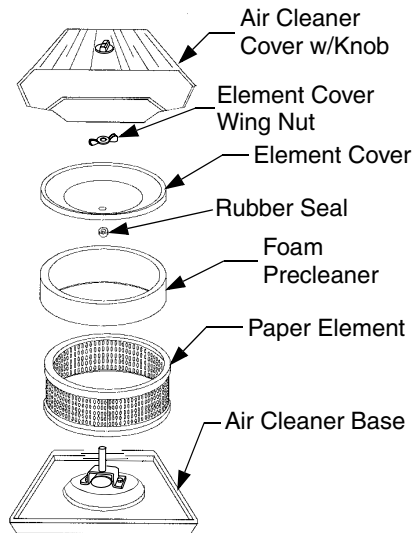

Figure 28



WARNING: Operating the engine with loose or damaged air cleaner components will allow unfiltered air into the carburetor, causing extensive wear and eventual failure of the engine.

Servicing The Precleaner

Wash and re-oil the foam precleaner more often under extremely dusty or dirty conditions. Refer to Figure 28.

- Loosen the air cleaner cover knob and remove the cover.
- Remove the foam precleaner by sliding it up off the paper element.
- Wash the precleaner in warm water with detergent. Rinse the precleaner thoroughly until all traces of the detergent are eliminated. Squeeze out (do not wring) excess water in a dry cloth. Allow the precleaner to air dry.
- Saturate the foam precleaner with new engine oil. Squeeze out all excess oil in a dry cloth.
- Reinstall the foam precleaner over the paper element.
- Reinstall the air cleaner cover and tighten the retaining knob to secure.

Servicing The Paper Element

Inspect and replace the paper element as necessary. Refer to Figure 28.

- Loosen the air cleaner cover knob and remove the cover.
- Remove the foam precleaner by sliding it up off the paper element.

- Clean the area around the element to prevent debris from getting into the engine when the element is removed.
- Loosen and remove the element cover wing nut.
- Remove the air filter element and element cover by lifting straight up.
- Do not wash the paper element or use pressurized air, as this will damage the element. Replace a dirty, bent or damaged element. Handle new elements carefully; do not use if the sealing surfaces are bent or damaged.
- When servicing the air cleaner, check the air cleaner base. Make sure it is secured and not bent or damaged. Check the element cover plate for damage or improper fit. Also check the rubber seal for damage or deterioration. Replace all damaged air cleaner components.
- Reinstall the paper element, foam precleaner, cover plate and element cover wing nut.
- Reinstall the air cleaner cover and tighten the retaining knob to secure.

IMPORTANT: *Properly maintained air cleaner elements significantly contribute to prolonging engine life.*

Servicing Oil Cooler

Inspect and clean the oil cooler, located next to the oil filter, after every 100 hours of operation.

Clean debris from the fins of the oil cooler with a brush or compressed air.

SECTION 9: TROUBLE SHOOTING

Possible Cause	Possible Remedy
Hard To Start	
No fuel in fuel tank or carburetor	Fill the tank with fuel. Check the fuel line, carburetor and fuel filter.
Fuel line or carburetor clogged	Clean the fuel line and carburetor with a commercial carburetor cleaner.
Fuel filter plugged	Replace
Water in fuel	Drain the fuel tank and carburetor. Use new fuel and dry the sparks plugs.
Choked improperly. Flooded engine	Follow the starting instructions.
Defective ignition or loose wiring	Check the wiring, spark plugs or fuse.
Defective battery	Check and service. Refer to "BATTERY."
Spark plug dirty or improperly gapped	Clean, adjust the gap to .030-inch or replace the plug.
Engine Operates Irregularly or Knocks	
Engine incorrectly timed	See your authorized dealer.
Spark plug dirty; wrong gap or wrong type	Clean, reset the gap or replace
Poor or weak spark	Check the spark plugs and wiring.
Carburetor setting incorrect	See your authorized dealer.
Poor grade fuel or water in fuel	Drain and use a good grade of clean fuel.
Engine overheating	Refer to "MAINTENANCE."
Engine valves at fault	See your authorized dealer.
Engine smokes	See your authorized dealer.
Oil level rises due to fuel in the crankcase	See your authorized dealer.
Air filter becomes oil and fuel soaked	See your authorized dealer.
Engine leaks oil	See your authorized dealer.
Misfiring	See your authorized dealer.
Other engine problems	See your authorized dealer.
Excessive oil in air cleaner	Fully seat oil dipstick, tighten oil fill cap, squeeze excess oil out of the pre-cleaner.
PTO Clutch Will Not Engage	
Reverse pedal is partially depressed	Depress brake pedal.
Vacuum actuator not energized	Check PTO switch and connections, check for worn or broken wiring.
Vacuum leak	Check vacuum lines.
Lack of Power	
Air cleaner clogged	Service the air cleaner element. Refer to "MAINTENANCE."
Engine overload	Reduce the load.
Engine overheated	Make sure the air intake screen, shrouding, engine fins, side panels, dash intake screen and grille are free of accumulated dirt and debris. Refer to "MAINTENANCE."
Fuel tank air vent clogged	Remove obstruction from the vent in the fuel tank cap.
Air leakage between carburetor and engine	Remove air cleaner. Tighten the carburetor and manifold mounting hardware. Replace any damaged parts as indicated in "MAINTENANCE."
Incorrect timing or faulty ignition	See your authorized dealer.

Possible Cause**Possible Remedy**

Brake dragging

Adjust the brakes. Refer to "**ADJUSTMENTS.**"Insufficient cooling air-dirt or debris clogging air intake screen • shrouds • cooling fins • side panels • dash intake screen • or grille
Oil level incorrectKeep the air intake area, side panels, grille, dash intake screen and cooling fins clean. Refer to "**MAINTENANCE.**"Engine oil level must not be over the "FULL" mark or below the "ADD" mark on dipstick. Refer to "**MAINTENANCE.**"**SECTION 10: OPTIONAL EQUIPMENT**

The following attachments and accessories are compatible with your Cub Cadet tractor. See your Cub Cadet dealer for information regarding price and availability.

Description	Model Number
44" Mower Deck	190-209-100
54" Mower Deck	190-295-100
50" Mower Deck	190-394-100
60" Mower Deck	190-291-100
Mechanical Angling Kit ⁽¹⁾	190-171-100
Hydraulic Angling Kit ⁽¹⁾	190-288-100
Front Hitch System	190-414-100
Grass Collection System (44" Deck)	190-212-100
Grass Collection System (48" Deck)	190-217B-100
Grass Collection System (190-295 54" Deck Only)	190-367-100
Grass Collection System (190-394 Deck Only)	190-284-100
54 Inch Blade ⁽²⁾	190-352-100
Snow Thrower ⁽¹⁾	190-353-100
3 Point Hitch	190-207-100
Hydraulic Tiller ⁽³⁾	190-004-100
Mulch Kit for 50" Deck	190-193-100
Mulch Kit for 54" Deck	590-507-100
10 Cu. Ft. Poly Cart	19A-106-100
18 Cu. Ft. Steel Cart	19A-102-100
Broadcast Spreader, Tow Behind	19A-105-100
48" Lawn Dethatcher, Tow Behind	19A-107-100
48" Lawn Spike Aerator, Tow Behind	19A-109-100
48" Lawn Plug Aerator, Tow Behind	19A-108-100
42" Lawn Sweeper, Tow Behind	19A-103-100
25 Gallon Sprayer, Tow Behind	19A-104-100
48" Lawn Roller	19A-113-100

- (1) Requires front hitch system 190-414-100.
- (2) Requires front hitch system 190-414-100. Can use optional Mechanical Angling Kit 190-171-100 or Hydraulic Angling Kit 190-288-100.
- (3) Requires 3 point hitch 190-207-100

SECTION 11: SPECIFICATIONS

Engine

Manufacturer	Kohler
Horsepower	25
Cylinders	2 (Command)
Cooling	Air
Fast Idle Speed	3600
Slow Idle Speed	1200
Displacement (cubic inches)	44.0
Compression Ratio	9.0:1
Spark Plug	RC12YC (Champion or equivalent)
Oil Filter	Cartridge
Crank Case Capacity	1.9 qt.

Electrical System

Charging System	Flywheel-Alternator
Capacity	15 Amp Regulated
Battery Type	Lead Acid
Battery Cold Cranking Amps at 0° F	435
Ignition	Battery
Fuses (auto type)	25 amp
Battery Voltage	12 Volts

Fuel System

Fuel Tank Capacity (gallons)	4.5
Type of Fuel	Unleaded
Fuel Filter	In-line

Drive Train

Transmission	Hydrostatic
Transmission Oil	Cub Cadet Drive System Fluid Plus
Transmission Oil Capacity	5.5 Qts.

Tires

Front (inches)	16 x 7.5 - 8
Rear (inches)	24 x 10.5 - 12

Dimensions and Weight

Wheelbase	49.5 in.
Overall Length	72.25 in.
Overall Width (w/o Attachments)	42 in.
Height	43.6 in.
Weight (w/o Mower Deck)	Approx. 803 lbs.
Turning Radius	27 in.
Ground Clearance	6 in.

Brakes

Type	External Disk
Parking	Foot Actuated - Hand Locked









PTO Clutch

Type	E-Vac System
------------	--------------

Attachment Lift System

Type	Hydraulic
------------	-----------

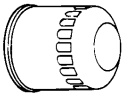
SECTION 12: Replacement Parts

Description	Part Number
Engine Oil 	737-3030A (10W30) 737-3049 (5W30)
Air Filter  <p style="text-align: center;">CARTRIDGE</p>  <p style="text-align: center;">FOAM PRE-CLEANER</p>	Order KH-24-883-03-S1 Air Filter Assembly
Engine Oil Filter 	KH-12-050-01-S
Spark Plug 	759-3336
Transmission Oil 	Cub Cadet Drive System Fluid Plus 737-3120 - Quart 737-3121 - Gallon
Transmission Oil Filter 	923-3014
Mower Deck Blades 	44" Deck -759-3939 (3) 54" Deck -759-3820 (3) 50" Deck -759-04047 (3) 60" Deck -759-3809 (3)
Mower Deck Belts 	44" Deck - 954-3098 54" Deck - 954-0197 50" Deck - 954-0295 60" Deck - 954-3093
PTO Belt (set of 2)	954-3084
Deck Spindles	618-3129C
Ignition Key	725-2054A
Solenoid	KH-25-435-06-S
Fuel Filter	KH-24-050-10-S

CALIFORNIA EMISSION CONTROL WARRANTY STATEMENT YOUR WARRANTY RIGHTS AND OBLIGATIONS

The California Air Resources Board and MTD Consumer Group Inc are pleased to explain the evaporative emission control system warranty on your 2007 lawn mower. In California, new lawn mower must be designed, built and equipped to meet the State's stringent anti-smog standards. MTD Consumer Group Inc must warrant the EECS on your lawn mower for the period of time listed below provided there has been no abuse, neglect or improper maintenance of your lawn mower.

Your EECS may include parts such as the carburetor, fuel-injection system, the ignition system, catalytic converter, fuel tanks, fuel lines, fuel caps, valves, canisters, filters, vapor hoses, clamps, connectors, and other associated emission-related components.

Where a warrantable condition exists, MTD Consumer Group Inc will repair your lawn mower at no cost to you including diagnosis, parts and labor.

MANUFACTURER'S WARRANTY COVERAGE:

This evaporative emission control system is warranted for two years. If any evaporative emission-related part on your equipment is defective, the part will be repaired or replaced by MTD Consumer Group Inc.

OWNER'S WARRANTY RESPONSIBILITIES:

As the lawn mower owner, you are responsible for performance of the required maintenance listed in your owner's manual. MTD Consumer Group Inc recommends that you retain all receipts covering maintenance on your lawn mower, but MTD Consumer Group Inc cannot deny warranty solely for the lack of receipts.

As the lawn mower owner, you should however be aware that MTD Consumer Group Inc may deny you warranty coverage if your lawn mower or a part has failed due to abuse, neglect, or improper maintenance or unapproved modifications.

You are responsible for presenting your lawn mower to MTD Consumer Group Inc's distribution center or service center as soon as the problem exists. The warranty repairs should be completed in a reasonable amount of time, not to exceed 30 days. If you have a question regarding your warranty coverage, you should contact the MTD Consumer Group Inc Service Department at 1-800-800-7310.

GENERAL EMISSIONS WARRANTY COVERAGE:

MTD Consumer Group Inc warrants to the ultimate purchaser and each subsequent purchaser that the lawn mower is: Designed, built and equipped so as to conform with all applicable regulations; and free from defects in materials and workmanship that cause the failure of a warranted part to be identical in all material respects to that part as described in MTD Consumer Group Inc's application for certification.

The warranty period begins on the date the lawn mower is delivered to an ultimate purchaser or first placed into service. The warranty period is two years.

Subject to certain conditions and exclusions as stated below, the warranty on emission-related parts is as follows:

1. Any warranted part that is not scheduled for replacement as required maintenance in the written instructions supplied, is warranted for the warranty period stated above. If the part fails during the period of warranty coverage, the part will be repaired or replaced by MTD Consumer Group Inc according to subsection (4) below. Any such part repaired or replaced under warranty will be warranted for the remainder of the period.

2. Any warranted part that is scheduled only for regular inspection in the written instructions supplied is warranted for the warranty period stated above. Any such part repaired or replaced under warranty will be warranted for the remaining warranty period.
3. Any warranted part that is scheduled for replacement as required maintenance in the written instructions supplied is warranted for the period of time before the first scheduled replacement date for that part. If the part fails before the first scheduled replacement, the part will be repaired or replaced by MTD Consumer Group Inc according to subsection (4) below. Any such part repaired or replaced under warranty will be warranted for the remainder of the period prior to the first scheduled replacement point for the part.
4. Repair or replacement of any warranted part under the warranty provisions herein must be performed at a warranty station at no charge to the owner.
5. Notwithstanding the provisions herein, warranty services or repairs will be provided at all of our distribution centers that are franchised to service the subject engines or equipment.
6. The lawn mower owner will not be charged for diagnostic labor that is directly associated with diagnosis of a defective, emission-related warranted part, provided that such diagnostic work is performed at a warranty station.
7. MTD Consumer Group Inc is liable for damages to other engine or equipment components proximately caused by a failure under warranty of any warranted part.
8. Throughout the lawn mower warranty period stated above, MTD Consumer Group Inc will maintain a supply of warranted parts sufficient to meet the expected demand for such parts.
9. Any replacement part may be used in the performance of any warranty maintenance or repairs and must be provided without charge to the owner. Such use will not reduce the warranty obligations of MTD Consumer Group Inc.
10. Add-on or modified parts that are not exempted by the Air Resources Board may not be used. The use of any non-exempted add-on or modified parts by the ultimate purchaser will be grounds for disallowing a warranty claims. MTD Consumer Group Inc will not be liable to warrant failures of warranted parts caused by the use of a non-exempted add-on or modified part.

WARRANTED PARTS:

The repair or replacement of any warranted part otherwise eligible for warranty coverage may be excluded from such warranty coverage if MTD Consumer Group Inc demonstrates that the lawn mower has been abused, neglected, or improperly maintained, and that such abuse, neglect, or improper maintenance was the direct cause of the need for repair or replacement of the part. That notwithstanding, any adjustment of a component that has a factory installed, and properly operating, adjustment limiting device is still eligible for warranty coverage. The following emission warranty parts list are covered: Fuel Line, Fuel Line Clampst cause of the need for repair or replacement of the part. That notwithstanding, any adjustment of a component that has a factory installed, and properly operating, adjustment limiting device is still eligible for warranty coverage. The following emission warranty parts list are covered: Fuel Line, Fuel Line Clamps

CUB CADET LLC MANUFACTURER'S LIMITED WARRANTY FOR SERIES 3000 TRACTORS

IMPORTANT: To obtain warranty coverage owner must present an original proof of purchase and applicable maintenance records to the servicing dealer. Please see the operator's manual for information on required maintenance and service intervals.

The limited warranty set forth below is given by Cub Cadet LLC with respect to new merchandise purchased or leased and used in the United States and/or its territories and possessions, and by MTD Products Limited with respect to new merchandise purchased or leased and used in Canada and/or its territories and possessions (either entity respectively, "Cub Cadet").

Cub Cadet warrants this product (excluding its *Normal Wear Parts, Batteries, Frame, Front Axle and Drive Shaft and Attachments* as described below) against defects in material and workmanship for a period of three (3) years or one hundred eighty (180) operation hours, whichever comes first, commencing on the date of original retail purchase or lease and will, at its option, repair or replace, free of charge, any part found to be defective in materials or workmanship.

Normal Wear Parts are warranted to be free from defects in material and workmanship for a period of thirty (30) days from the date of original purchase or lease. Normal wear parts include, but are not limited to items such as: belts, blades, blade adapters, grass bags, rider deck wheels, seats, and tires.

Batteries have a one-year prorated limited warranty against defects in material and workmanship, with 100% replacement during the first three months. After three months, the battery replacement credit is based on the months remaining in the twelve (12) month period dating back to the original date

of original sale or lease. Any replacement battery will be warranted only for the remainder of the original warranty period.

Frame, Front Axle and Drive Shaft — Cub Cadet warrants the frame, front cast iron pivot axle and drive shaft against defects in material and workmanship for a period of five (5) years or 500 hours, whichever occurs first, commencing on the date of original purchase or lease.

Attachments — Cub Cadet warrants attachments for this product against defects in material and workmanship for a period of two (2) years, commencing on the date of the attachment's original purchase or lease. Attachments include, but are not limited to items such as: grass collectors and mulch kits.

This limited warranty shall only apply if this product has been operated and maintained in accordance with the Operator's Manual furnished with the product, and has not been subject to misuse, abuse, neglect, accident, improper maintenance, alteration, vandalism, theft, fire, water, or damage because of other peril or natural disaster. Damage resulting from the installation or use of any part, accessory or attachment not approved by Cub Cadet for use with the product(s) covered by this manual will void your warranty as to any resulting damage. In addition, Cub Cadet may deny warranty coverage if the hour meter, or any part thereof, is altered, modified, disconnected or otherwise tampered with.

HOW TO OBTAIN SERVICE: Warranty service is available, WITH PROOF OF PURCHASE AND APPLICABLE MAINTENANCE RECORDS, through your local authorized service dealer. To locate the dealer in your area:

In the U.S.A.:

Check your Yellow Pages, or contact Cub Cadet LLC at P.O. Box 361131, Cleveland, Ohio 44136-0019, call 1-877-282- 8684 or log on to our website at www.cubcadet.com.

In Canada:

Contact MTD Products Limited, Kitchener, ON N2G 4J1, call 1-800-668-1238 or log on to our website at www.mtdcanada.com.

Without limiting the foregoing, this limited warranty does not provide coverage in the following cases:

- a. Routine maintenance items such as lubricants, filters, blade sharpening, tune-ups, brake adjustments, clutch adjustments, deck adjustments, and normal deterioration of the exterior finish due to use or exposure.
- b. Service completed by someone other than an authorized service dealer.
- c. Cub Cadet does not extend any warranty for products sold or exported outside of the United States and/or Canada, and their respective possessions and territories, except those sold through Cub Cadet's authorized channels of export distribution.
- d. Replacement parts and/or accessories that are not genuine Cub Cadet parts.
- e. Transportation charges and service calls.

There are no implied warranties, including **without limitation any implied warranty of merchantability or fitness for a particular purpose. No warranties shall apply after the applicable period of express written warranty above. No other express warranties beyond those mentioned above,**

given by any person or entity, including a dealer or retailer, with respect to any product, shall bind Cub Cadet. The exclusive remedy is repair or replacement of the product as set forth above. The terms of this warranty provide the sole and exclusive remedy arising from the sale and/or lease of the products covered hereby. Cub Cadet shall not be liable for any incidental or consequential loss or damage including, without limitation, expenses incurred for substitute or replacement lawn care services or for rental expenses to temporarily replace a warranted product.

Some jurisdictions do not allow the exclusion or limitation of incidental or consequential damages, or limitations on how long an implied warranty lasts, so the above exclusions or limitations may not apply to you.

In no event shall recovery of any kind be greater than the amount of the purchase price of the product sold. **Alteration of safety features of the product shall void this warranty.** You assume the risk and liability for loss, damage, or injury to you and your property and/or to others and their property arising out of the misuse or inability to use the product.

This limited warranty shall not extend to anyone other than the original purchaser or to the person for whom it was purchased as a gift.

HOW LOCAL LAWS RELATE TO THIS WARRANTY: This limited warranty gives you specific legal rights, and you may also have other rights that vary in different jurisdictions.