

INSTALLATION AND OPERATING INSTRUCTIONS FOR AQ-1 POWER VENT KIT

DESIGNED FOR

BOSCH 425 HN WATER HEATERS

AQUASTAR 125B WATER HEATERS

INCLUDING AQUASTAR MODELS: 125HX • 125BS • 125X • 125BL

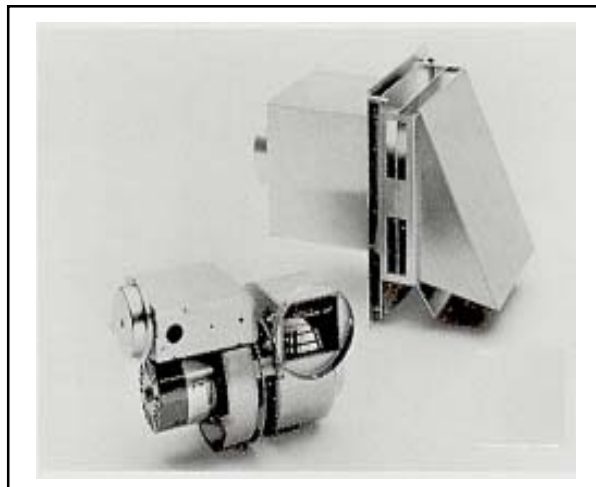

TABLE OF CONTENTS

contents with an AQ-1 power vent	p.1
mounting gas pressure switch	p.2
mounting linear spillage switch	p.4
common setup	p.6
locating vent hood (clearances)	p.7
mounting power vent motor (clearances)	p.7
troubleshooting and maintenance	p.9
safety interlock test	p.10
AQ-1 wiring diagram	p.11
vent hood template	p.12

AQ-1 *Power vent kit*

Parts included:

Spillage Switch Kit

1. 185° F linear spillage switch mounted on an angled bracket and equipped with 36 inch cables connected to one eyelet terminal and one 1/4" quick connect terminal
2. Spillage switch mounting screw
3. Push on male spade connector, replaces eyelet terminal from 36 inch spill switch cable.

Vent Hood Kit

1. 4" vent hood: VH1-4
2. Plastic wall anchors (4)
3. Sheet metal screws (4)
4. **5" to 4" vent reducer pipe**

Vibration Mount Packet

1. Vibration mounts (2) with nuts and washers
2. Brackets (2) with nuts and washers

Gas Pressure Switch Packet

1. Gas pressure switch
2. Self-tapping mounting screws (4)
3. Manifold pressure tap fitting with 1/4" compression nut and sleeve
4. 1/4" by 40" aluminum tubing (2)

Power Vent Kit

1. Power venter (HSUL-1 Series containing integrated 24v control circuit) including 25 foot control cable with 1/4" quick connect ends and an HPN 6 foot power cord
2. Nylon ties

Before beginning installation review required clearances for Water Heater, Power Vent Motor and Vent Hood

Power Vent Kit

CAUTION

1. Failure to install, maintain and/or operate the Power Venter in accordance with manufacturer's instruction may result in conditions which can produce bodily injury and property damage.
2. The Power Venter must be installed by a qualified installer in accordance with all local codes or, in their absence, in accordance with the National Fuel Gas Code (ANSI Z223.1/NFPA #54), the National Electric Code and The Occupational Health and Safety Act (OSHA) as applicable.
3. The Power venter motor shaft must be mounted horizontally to prevent motor bearing wear.
4. Disconnect power supply when making wiring connections or when working around the fan blade and motor. Failure to do so may result in severe personal injury and equipment damage.
5. Make certain the power source is adequate for the fan motor requirements. Do not add the power venter to a circuit where the total load is unknown.
AQ-1 Motor is 200 watts- 1.66 amps @ 120vac

Bosch-Aquastar

1. Follow installation and operating instructions manual supplied with the water heater.
2. Before mounting water heater to wall, check its minimum clearance requirements.
3. When using an AQ-1 the maximum horizontal distance from the water heater to the power vent motor is 100 feet. Subtract 10 feet for each added elbow. **Install power vent motor as close to the termination as possible to maintain the water heater's optimal efficiency.**

IMPORTANT: FREEZE PREVENTION TO HEATER

In cold climates, ensure the proper closure of the backdraft flapper when the heater is not running. If the backdraft flapper does not close properly, cold air can enter the vent pipe and freeze the heater's heat exchanger when not in use. Such damage is not covered under the water heater's warranty.

Gas Pressure Switch

Remove the gas pressure switch from the bag in the carton and the brass 1/4" compression nut fitting which is meant for the burner manifold tap on the heater, **not the inlet tap on the heater's gas inlet pipe** (see p. 3, Fig B). Also remove the four self-tapping screws and the two sections of 1/4" diameter aluminum tubing from the master carton.

The gas pressure switch must be mounted in such a way that the diaphragm is oriented vertically and the aluminum tubing pieces can easily reach the manifold pressure test nipple and the burner respectively. **It must not be mounted inside the heater.** See Figure E p.6

When mounting the Gas Pressure Switch: We recommend mounting the gas pressure switch vertically against a wall on the lower left side of the water heater. See Figure E p.6. Because the cabinet cover is three sided we do not recommend screwing the gas pressure switch to the left side of it. Instead, mount the gas pressure switch vertically against a wall on the lower left side of the water heater. Installed in this manner all necessary connections will be within reach and there will be minimal interference when servicing.

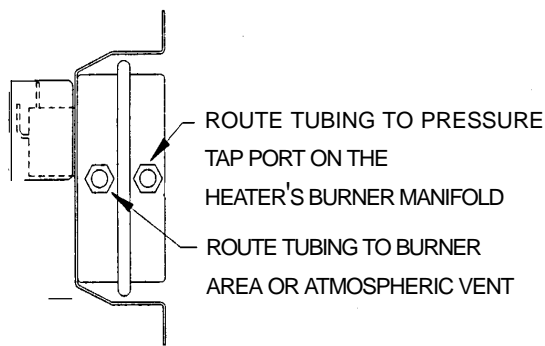

FIGURE A

PRESSURE TAP-GAUGE PORT
(WHERE HEATER'S BURNER
MANIFOLD PRESSURE CAN BE
MEASURED)

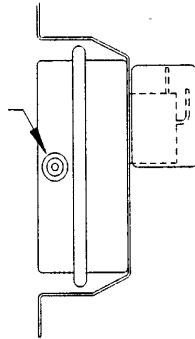
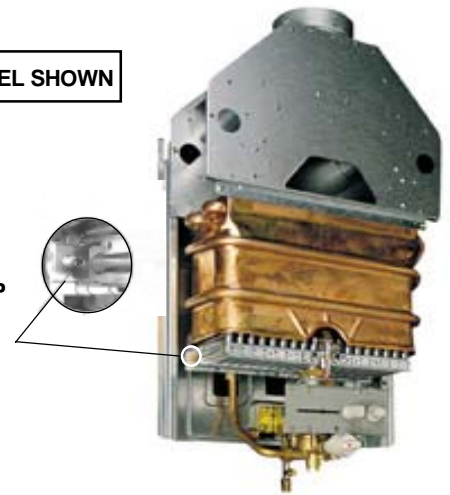

FIGURE B

125B MODEL SHOWN

MANIFOLD TAP



INSTRUCTIONS (SEE DIAGRAMS ABOVE)

1. Mount gas pressure switch by securing it to the chosen location with a screw in each one of the four mounting holes.
2. Use a tube cutter to make a clean cut (not crimped) at each end of the two lengths of the 1/4" aluminum tubing. One tube must be long enough to reach from the fitting marked "connect to gas valve" to the pressure tap port on the heater's burner manifold (**Not to the inlet gas pressure port of the water heater since there will be constant gas pressure there**). The tube must be long enough to enter the bottom of the water heater front cover and attach to the burner manifold without difficulty (See Figure B). The second tube must be long enough to reach from the gas pressure switch to the burner area, but not in the pilot flame area. Allow enough slack for very gradual bends. (See Figure A for gas pressure switch ports).
3. **ATTENTION** - Failure to follow the next series of instructions may result in breaking a part.
 - a. Remove the brass pressure tap fitting from the burner manifold of the water heater. **This fitting will not be required for reuse.**
 - b. Bend one 1/4" aluminum tubing so that it will run from the gas pressure switch to where the fitting attaches to the burner manifold. Make gradual bends - do not crimp the tube.
 - c. Do not connect to burner manifold, first assemble the 1/8" NPT male by 1/4" compression fitting with nut and sleeve to this end of the aluminum tube. Tighten the fitting and nut with two wrenches.
 - d. Separate the joint just made in step 3.c.

e. Hand thread the pressure tap fitting into the heater's burner manifold. Use a small amount of an appropriate thread sealant on the male end of the fitting. **Over tightening of the fitting will break it.**

f. Guide the end of the tube into the compression fitting. While using one wrench to hold back the pressure tap fitting, gently snug-up the compression nut with a second wrench.

4. Bend the second piece of aluminum tubing (from step 2) so that it will reach from the gas pressure switch through the underneath of the heater to an area below the burners. Connect one end of the tube to the fitting marked "warning" on the gas pressure switch. **The other end of the tubing should now extend to burner area close to pilot, position it just below the stainless steel burners.** This tube should not discharge into the flame nor should it extend above the upper edge of the burners. This tube vents gas to the combustion chamber for ignition in case of a diaphragm failure in the gas pressure switch.

NOTE: The gas pressure switch has a built in pressure tap marked "gauge port". Use this tap instead of the heater's manifold tap when checking manifold pressure. (See Figure A)

Linear Spillage Sensing Switch

This switch provides a means for safety shut down of the water heater in the event of flue blockage or power venter failure. If hot flue gasses spill from the draft hood diverter, the draft spillage sensing switch will open the pilot safety circuit and shut off all gas to the water heater. The switch is normally closed and opens at temperatures greater than 185° F. It has a manual reset button.

INSTRUCTIONS

1. The entire length of the copper capillary sensing tube is heat sensitive. The idea is to suspend the tube within close proximity of the heater's draft hood diverter. **Note: do not cut the copper capillary sensing tube.**
2. The linear spill switch should mount in a location where the tube can extend across the top of the draft diverters while allowing the switch cables to reach the ECO. (See Figure C, page 5)
3. Route the cables to the ECO switch inside the water heater keeping the cables out of contact with hot surfaces.

SAFETY CIRCUIT

The linear spill switch, when wired in series with the Thermocouple or Pilot Flame Sensor and ECO(s) of the water heater, form the Safety Circuit.

1. **The ECO is mounted on the lower left outlet water pipe.** (See figure C)

- a. Remove one lead connecting to ECO terminal, it does not matter which one is disconnected.
- b. Attach 1/4" quick connect terminal end of linear spill switch cable to now exposed terminal of the ECO.
- c. Remove the eyelet ended terminal from the other spill switch cable. Affix the push on male spade connector, which is provided with the AQ1, to this spill switch cable.
- d. Connect this male spade connector to the removed lead wire from step 3.a.

The linear spill switch should be attached to the upper right-hand side on the draft hood diverter (see figure D), on the Model 425HN and 125HX the linear spill switch should be attached to the upper left-hand side of the draft hood diverter. There are two holes provided for attachment on this diverter and only the front most hole should need to be used. With the provided #12 self tapping sheet metal screw securely mount the spill switch bracket to the diverter. For ease of access position it so the reset button faces outward and then bend the bracket so the switch can stand vertically.

The copper capillary sensing tube should then be directed to the opposite end of the draft hood diverter, by laying it in front of the 5" diameter vent pipe opening, and down the other side of the draft hood diverter.

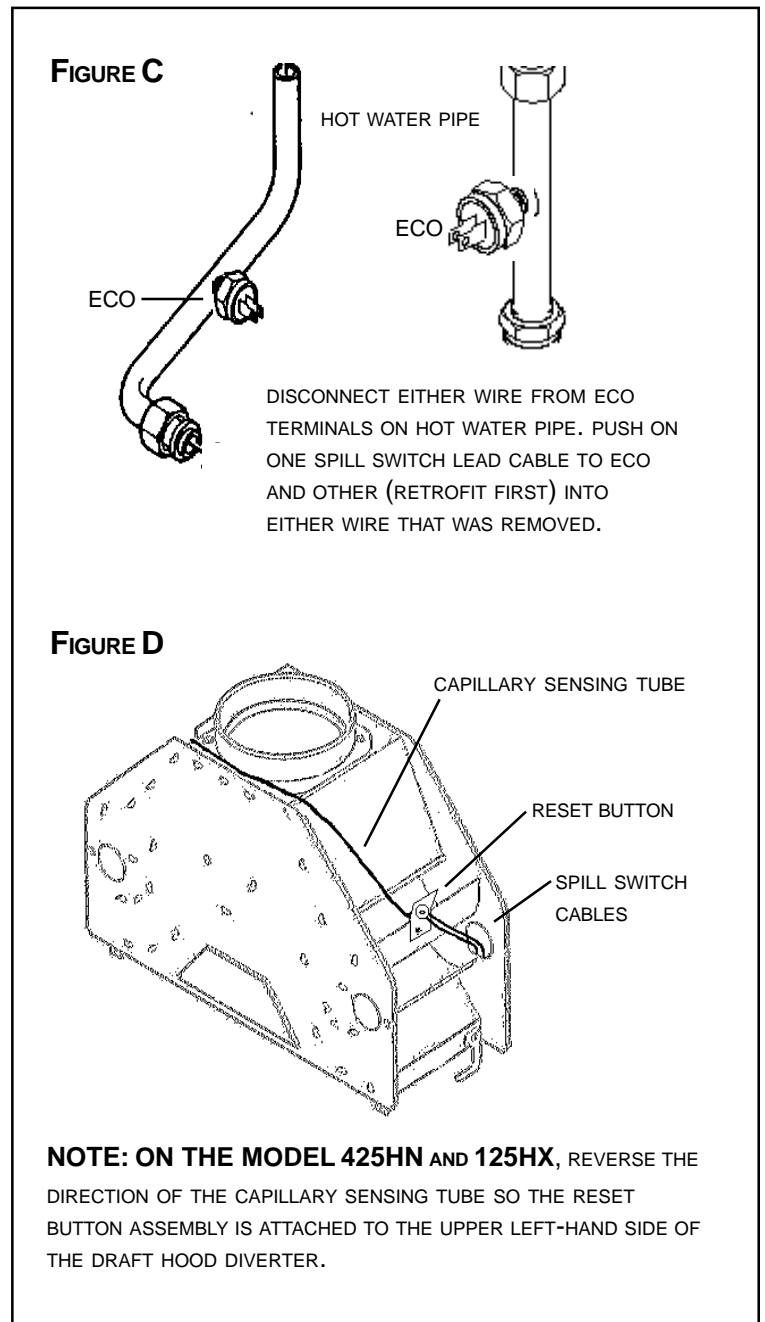

COMMON SETUP

4" single wall pipe* (galvanized or stainless steel) or 4" B-type vent*.

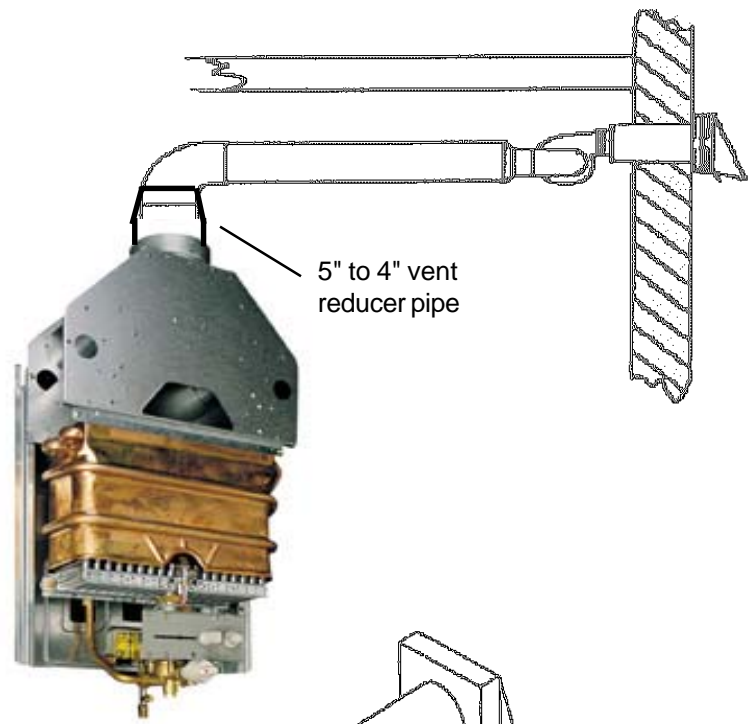
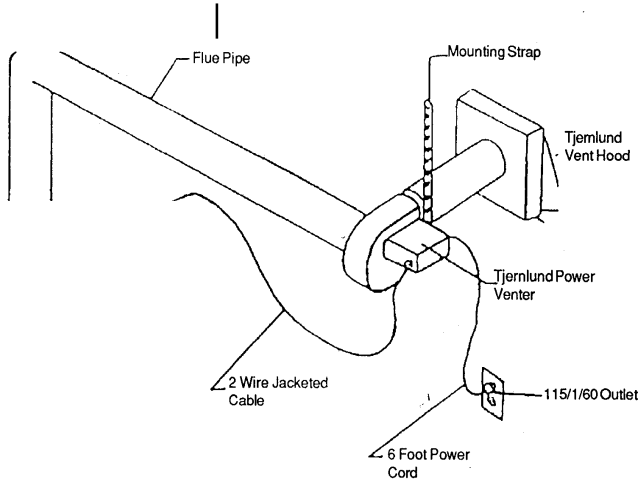

* Single wall vent pipe requires a 6" clearance to combustibles. B-type vent (double wall) requires a 1" clearance to combustibles. Use of B-type vent is not permissible downstream outlet side of the fan motor. Any additional vent pipe used between the fan motor and the vent hood must be positive pressure rated with all seams sealed to prevent leakage. Single wall galvanized or stainless steel pipe is best.

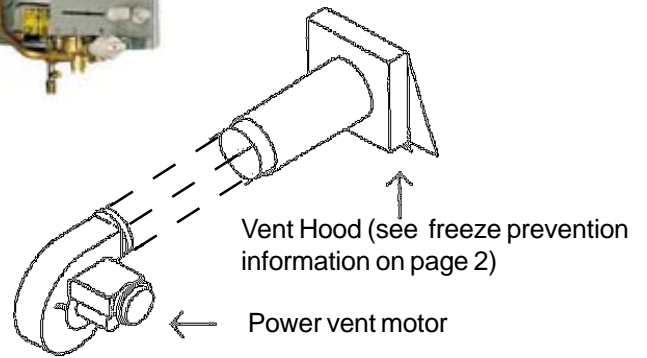

FIGURE E

125B Model shown

Mount gas pressure switch against wall



See Figure D, page 5 for location of Linear Spillage Switch

NOTE: FOLLOW REQUIREMENTS IN FIGURES F & G ON THIS PAGE BEFORE INSTALLING VENT HOOD, THEN USE TEMPLATE ON PAGE 13 TO CUT HOLE.

CAUTION
 Failure to follow these installation instructions may violate applicable national and/or local codes

The vent system must terminate so that proper clearances are maintained as cited in the National Fuel Gas Code, ANSI Z223.1

"The exit terminals of mechanical vent system shall be located not less than 7 feet above grade when located adjacent to a public walkway. The venting system shall terminate at least 3 feet above any forced air inlet within 10 feet. The venting system shall terminate at least 4 feet below, 4 feet horizontally from or 1 foot above any door, window or gravity air inlet into any building." Also, "The vent terminal shall also not be installed closer than 3 feet from the inside corner of an L-shaped structure, or less than 1 foot above grade."

FIGURE F

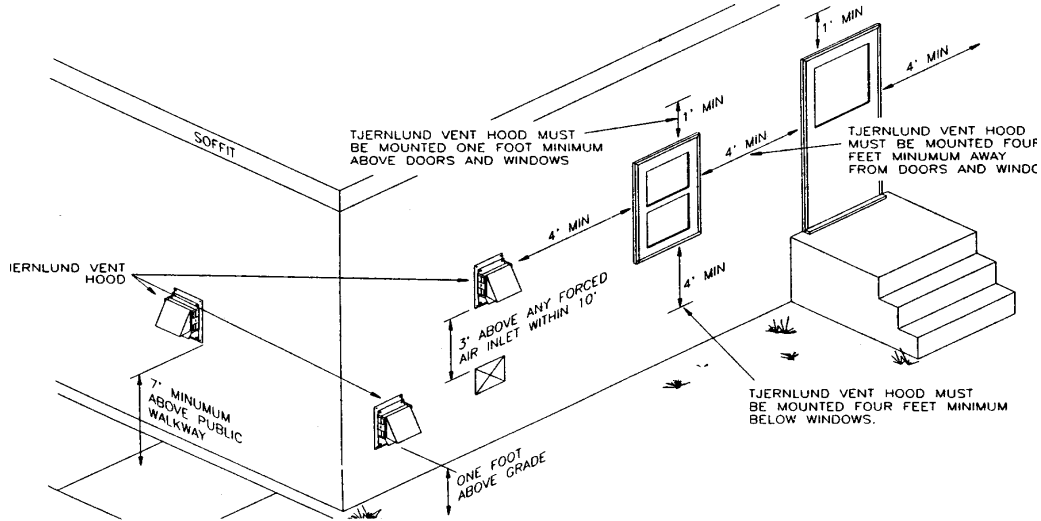

POWER VENT FAN AND MOTOR

Code Requirements

Power vent installation must be in accordance with the following requirements of the National Fuel Gas Code:

- All portions of the vent system under positive pressure during operation (on the downstream outlet side of the fan motor) shall use galvanized or stainless steel single wall vent pipe and be sealed to prevent leakage of flue gases.
- Provisions shall be made to interlock the appliance(s) to prevent the flow of gas to the main burners when the draft system is not performing so as to satisfy the operating requirements of the equipment for safe performance. (Linear spillage switch: p.4)

Installation Restrictions

1. Power vent motor should be installed as close to the termination of the vent system as possible to obtain optimal appliance efficiency and to prevent flue gas leakage.

2. Power venter must be mounted with motor shaft horizontal to prevent motor bearing wear.
3. Power venter housing is single walled. A 6" clearance from combustible material must be maintained. (See Figure G)
4. Position the 5" to 4" reducer pipe on top of the heater first and then connect a 4" 90° elbow to begin the horizontal run. Observing this guideline will help to establish a proper draft.

FIGURE G

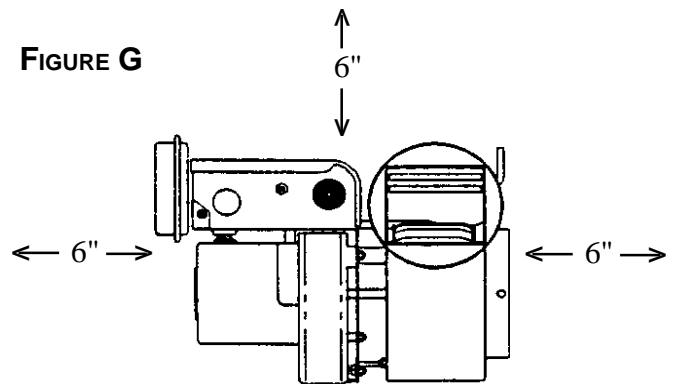

INSTRUCTIONS

(DO NOT BEGIN THESE PROCEDURES UNTIL VENT HOOD HAS BEEN INSTALLED)

1. Remove vibration mounts, nuts and washers from parts bag. Install on power venter as shown in (Figure H).
2. To prevent vibration, securely support power venter from ceiling or joist using a plumber's strap or wire fastened to the vibration mounts. As an alternative means of support, a wall bracket may be used to support the underside of the motor. (NOTE: Plumbers strap, wire or wall bracket must be supplied by installer.)
3. Connect the power venter outlet to the inner sleeve of the vent hood. (See page 6 for vent piping requirements). Use the 4 pre-punched holes in the outlet collar of the power venter as a guide to drill 1/8" diameter holes into the vent pipe. Fasten power venter outlet to the vent hood inlet (or single wall pipe, depending on if additional piping is being used between the venter and the hood) using sheet metal screws.
4. Any vent pipe connections used after the power venter (between it and the vent hood) will be under positive pressure during operation. The vent pipe must be galvanized or stainless steel single wall vent pipe. The connections must be sealed with high temperature silicone sealant or aluminum vent pipe tape supplied by the installer.
5. Install properly sized vent pipe connections from the power venter inlet to the water heater's outlet, avoiding elbows wherever possible. Position the 5" to 4" reducer pipe on top of the water heater first and then connect a 4" 90° elbow to begin the horizontal run. Observing this guideline will help to establish a proper draft. When using an AQ-1 the maximum horizontal distance from the water heater to the power vent motor is 100 feet. Subtract 10 feet for each added elbow.
6. Support the vent pipe in accordance with vent manufacturer's instructions. Vent pipe is not supplied in the power venter package, except for the 5" to 4" reducer vent pipe in the AQ-1. Observe the clearances associated with the class of vent pipe used.

FIGURE H

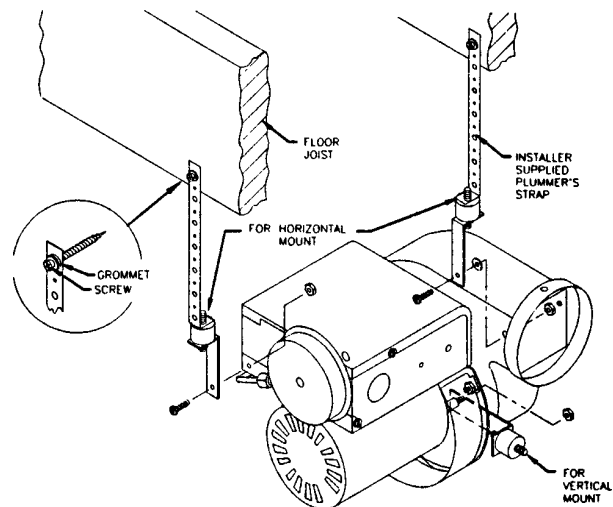

Installation - Electrical

1. Route the control cable from the power venter fan along the ceiling or joists down to the gas pressure switch, taking care not to come closer than 6" to the vent pipe or any other potentially hot surface. In many cases, the gas supply piping can be used as a routing path from the ceiling down to the controls, using the supplied nylon ties to secure the cable.
2. Connect the BLUE wire from the jacketed power vent cable onto the normally open terminal of the gas pressure switch. (See Figure I)

3. Connect the RED wire from the jacketed cable onto the common terminal of the gas pressure switch. (See Figure I)

NOTE: If the distance between the power venter and the gas pressure switch is greater than the length of the cable, splice a section of 2 conductor, PVC sheathed, 105° C thermostat cable to the supplied cable. Make sure that the colored leads remain consistent.

FIGURE I

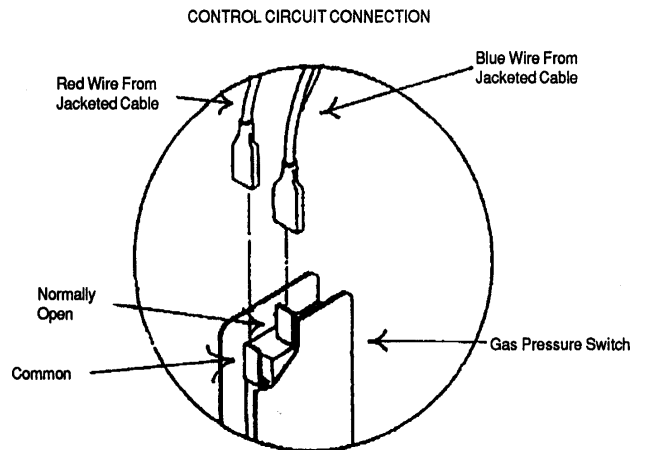

TROUBLE-SHOOTING, MAINTENANCE AND TEST PROCEDURES

Vent System Maintenance

The vent system must be inspected at regular 3 month intervals. Points of inspection are as follows:

1. Screened opening of the vent hood should be free from foreign material and cleaned as necessary.
2. Check all vent system connections for leakage and reseal where needed. If any vent pipe shows signs of deterioration, replace immediately and check new connections for possible leaks. Reseal using RTV Red HiTemp Silicone Sealer or equivalent. Inspect proper closure of the back draft flapper and correct if it does not close properly after use.

Gas Pressure Switch Test

1. Follow the water heater operating instructions to light the pilot / operate the heater.
2. Open a hot water outlet. This should energize the power vent system. Next close the hot water outlet to de-energize the venter.
3. Repeat step 2 to assure proper operation.
4. If power venter does not energize, check that the gas pressure switch tubes are properly connected and that the tube ends are not pinched closed.

5. Make sure pressure switch is mounted in such a way that the diaphragm is oriented vertically.

Combustion Air Test

1. Close all doors and windows of the building. If the water heater is installed in a utility room or closet, close the entrance door to this room. Close fireplace dampers.
2. Turn on any clothes dryers. Turn on all exhaust fans, such as a range hood, bath room exhaust fans and whole house fans, to maximum speeds. (Do not turn on any fans used strictly for summer exhausting).
3. Open a hot water tap to full flow.
4. Allow all fans and the water heater to operate for five (5) minutes.
5. Tripping of the spillage switch circuit (resulting in shut down of the heater) during the 5 minute operation indicates an unsafe operating condition. Turn off gas supply to water heater and **DO NOT OPERATE UNTIL UNSAFE VENTING CONDITION IS INVESTIGATED BY A PROFESSIONAL CONTRACTOR OR UTILITY SERVICE PERSONNEL.**
6. Return all windows, doors and fans to their previous condition of use.

SAFETY INTERLOCK TEST

1. Open the gas supply to the water heater.
2. Remove the vent pipe from the vent connector on the top of the water heater.
3. Block the vent connector with sheet metal or other noncombustible material.
4. Turn on the hot water supply to allow the burner to activate. Hot flue gasses will spill from the draft diverter momentarily. In less than three (3) minutes, the linear spillage switch should trip, opening the electric circuit to the electromagnet valve and halting the flow of gas to the burner.

NOTE: If spillage switch does not shut off the gas, check that you have made the proper safety circuit connections. If the switch still does not trip, contact Bosch Water Heating at 800 642 3111. **NOTE:** Models with built in flue gas sensors (mounted on draft diverter) may cut out operation of the heater before the spillage switch does. This is not an error of the spillage switch.

5. After the burners shut off, turn off hot water supply and wait 2-3 minutes...then push the reset button on the linear spillage switch.
6. Light pilot or operate heater and repeat Safety Interlock Test, (Step 1-5)
7. Reconnect the vent pipe to the venting system when complete.

CAUTION: Metal vent pipe and vent blockage metal will be hot.

In the Event of Pilot/Burner Outage

1. Push the reset button located in the center of the linear spillage sensing switch.
2. Verify that there is 115V power provided to the Power Venter. This can be done by checking the circuit breaker and electrical connections.
3. Visually verify that all the connections of the control cord circuit are intact.
4. Follow heater installation and operating instructions for relighting the heater.

5. Perform the operation circuit test and safety circuit check. (See Safety Interlock Test)

TROUBLESHOOTING THE POWER VENTER

1. **Fan Motor runs all the time:** Make sure the pressure tube that connects to the heater is properly connected to the burner manifold, not the inlet gas pressure tap at the bottom of the unit. See Figure B on page 3.
2. **Pilot will not hold when manually lit or spark automatically with hot water flow:** Check the linear spill switch reset button. If this corrects the symptom, then either there was a power outage in the home while the heater was operating or the heater's flue gases are not being properly discharged through the power vent (see CAUTION box below).

If resetting the linear spill switch did not correct the problem then reference this symptom in the troubleshooting section of the water heater manual.

CAUTION: If for any reason the system has shut down during operation, the cause of the system failure should be investigated and corrected before resetting the safety switches and lighting the pilot.

If you have any questions with regard to this installation, please call Bosch Water Heating at 800 642 3111.

IMPORTANT: FREEZE PREVENTION TO HEATER

In cold climates, ensure the proper closure of the backdraft flapper when the heater is not running. If the backdraft flapper does not close properly, cold air can enter the vent pipe and freeze the heater's heat exchanger when not in use. Such damage is not covered under the water heater's warranty.

AQ - 1 WIRING DIAGRAM

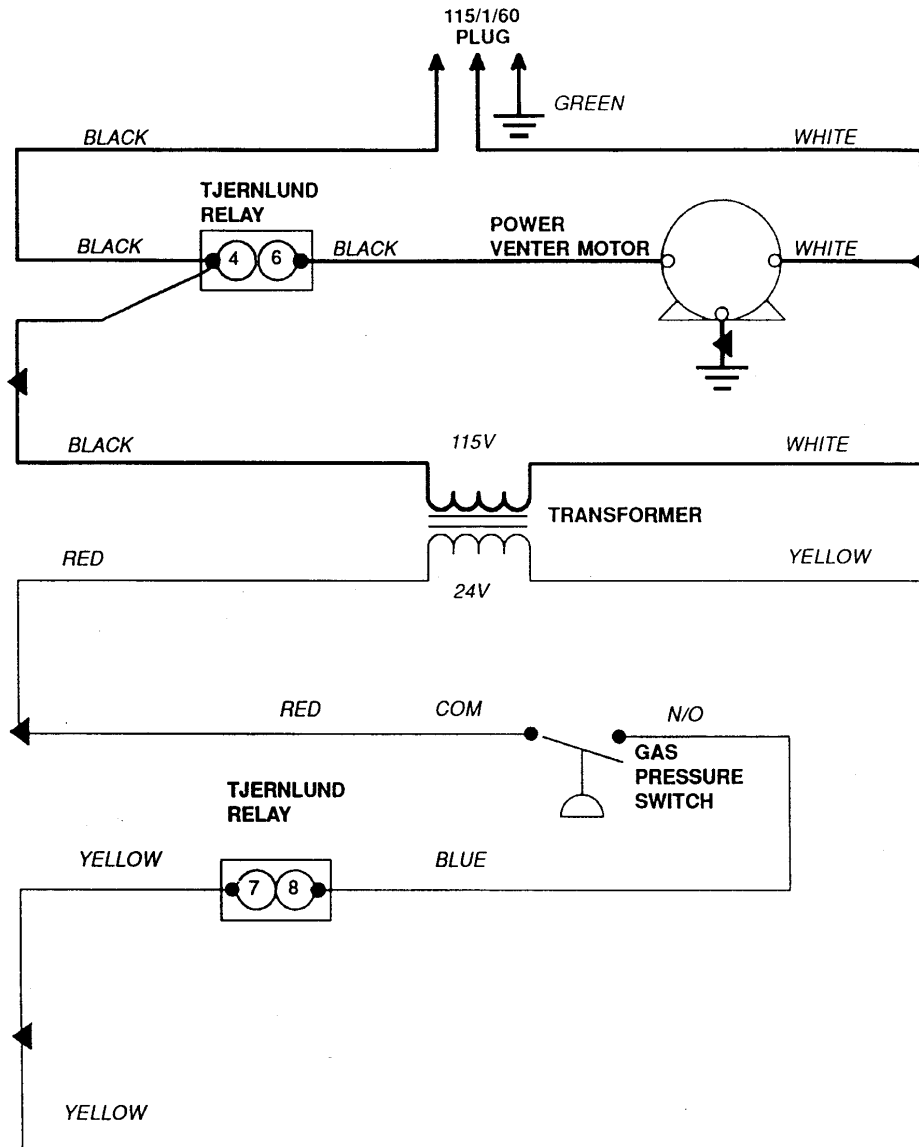

Legend

- Denotes line voltage factory wiring
- ==== Denotes low voltage factory wiring
- Denotes wire nut
- ➔ Denotes quick connect

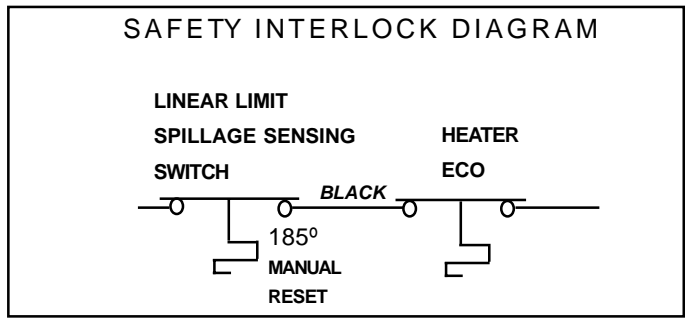

1. Attach this template to the interior of the wall the Vent Hood will be penetrating.
2. Insure that proposed vent termination clearances are met before cutting opening through wall. Using a 1/2" drill bit, drill two pilot holes where noted on this template. The drill bit must be long enough to penetrate to the building exterior.
3. Attach this template to the building exterior aligning the pilot holes on the template with the pilot holes drilled in step 2.
4. Using a reciprocating saw, cut a hole through the building siding, wall board, etc., following the appropriate lines of this template.
5. Slide the vent hood through the opening and fasten to exterior wall using provided screws.
6. Once Power Venter is completely installed and secured, apply a bead of exterior rated caulk between Vent Hood flange and exterior of building.

VH1-4 (SQUARE) VENT HOOD INSTALLATION TEMPLATE
 ACTUAL HOOD SIZE 7½" X 7½" (ROUGH IN SHOULD BE 8" X 8")

