

Crestron **CLW-SW1/4RF,**
CLW-SWS1/4RF, CLW-SLVS1RF
infiNET™ Switches

Operations Guide



This document was prepared and written by the Technical Documentation department at:



Crestron Electronics, Inc.

15 Volvo Drive

Rockleigh, NJ 07647

1-888-CRESTRON

All brand names, product names and trademarks are the property of their respective owners.

©2007 Crestron Electronics, Inc.

Contents

infiNET™ Switches: CLW-SW1/4RF, -SWS1/4RF, -SLVS1RF	1
Introduction	1
Features and Functions	1
Specifications	3
Physical Description	4
Industry Compliance	7
Acquire the Switch on the infiNET Network.....	8
Operation	10
Identity Code	13
Programming Software	22
Earliest Version Software Requirements for the PC	22
Programming with D3 Pro.....	23
Programming with SIMPL Windows	23
Example Program	25
Uploading and Upgrading.....	26
Establishing Communication.....	26
Programs and Firmware	26
Program Checks	27
Problem Solving	28
Troubleshooting.....	28
Bootloader.....	29
Reference Documents.....	30
Further Inquiries	30
Future Updates	30
Return and Warranty Policies.....	31
Merchandise Returns / Repair Service	31
CRESTRON Limited Warranty.....	31

infiNET™ Switches: CLW-SW1/4RF, -SWS1/4RF, -SLVS1RF

Introduction

Features and Functions

The CLW-SW1RF (-SW1RF) one-button switch and CLW-SW4RF (-SW4RF) four-button switch are stand-alone wall box switches that can also act as wireless infiNET™ devices that report to a Crestron® control processor via a Crestron infiNET wireless gateway.

infiNET Switches Functional Summary

- Two-way infiNET switches
 - ⇒ 2.4 GHz infiNET mesh network technology
 - ⇒ Range up to 150 feet indoors, or 250 ft outdoors (subject to site-specific conditions)
 - ⇒ Range may be increased with the use of additional infiNET devices or C2N-MNETRPT repeaters
 - ⇒ “Wi-Fi” friendly operating frequency to avoid interference
- One-button and four-button configurations available in white, black, and almond
- Can be ordered with custom-engraved buttons
- Can operate as a local load control or infiNET keypad.

These switches can be operated with a user-adjustable delay up to 10 minutes and 55 seconds. For more information, refer to “Operation” on page 10 for more information.

These infiNET switches are a part of Crestron’s line of lighting products using infiNET mesh network technology. infiNET technology is “Wi-Fi” friendly and provides fault tolerance and increased effective signal strength as network devices are added.

As an infiNET device, these switches communicate with a Crestron control system via a C2N-MNETGW infiNET Gateway. Up to 30 infiNET devices (including C2N-MNETRPT infiNET Repeater) can communicate with one C2N-MNETGW

infiNET Gateway and, if more devices are needed, more C2N-MNETGW gateways may be added to a Cresnet® network.

Crestron infiNET switches operate on the 2.4 GHz “ISM band” (2400 MHz to 2483.6 MHz) at 10 mW. The output power of these devices allow RF signals to travel approximately 150 feet indoors and 250 feet outdoors (subject to site-specific conditions) without the use of repeaters or other infiNET devices. The range is dependent on construction of the building, obstructions, and RF interference from other devices. The location of the switch is an important factor in determining RF performance. Adding more infiNET devices or repeaters to the network effectively increases the range, strength, and reliability of the network.

The -SW1RF and -SW4RF feature a three-position mode selection switch. Refer to “Operation” on page 10 for more information. In the absence of control system communications, the switch can still be used to control the attached load.

The CLW-SWS1RF (-SWS1RF) and CLW-SWS4RF (-SWS4RF) are similar to the -SW1RF and -SW4RF (respectively) with the added capability of working with one or more slave units (CLW-SLVS1RF) in a multi-switch / single circuit application. For more information, refer to the latest version of the infiNET Switches Installation Guide (Doc. 6293) which is available from the Crestron website (www.crestron.com/manuals).

The CLW-SLVS1RF (-SLVS1RF) is a slave unit that when used in conjunction with the -SWS1RF or -SWS4RF acts as an additional switch control point in a multi-switch / single circuit application. It does not connect to an infiNET system and cannot be used without a -SWS1RF or -SWS4RF. The -SLVS1RF does not have a mode selection switch. It can only be programmed when used in conjunction with a -SWS4RF (refer to the SIMPL™ Windows® help file). Otherwise, it will emulate the RUN mode of the -SWS1RF (even if connected to a -SWS4RF) unless the mode selection switch of the master is set to “OFF”.

These switches can be ordered with custom engraved buttons already installed by Crestron. Engraved buttons cannot be installed or changed in the field. Contact Crestron for more information.

These switches are available in a variety of colors and textures. The table below shows the availability.

Available Colors/Textures

COLOR/ TEXTURE	MODEL NUMBER SUFFIX	MATCHING FACEPLATE (Lutron® Part Number Shown)
White	W	Not Applicable
Smooth White	W-S	CW-1-WH
Almond	A	CW-1-LA
Smooth Almond	A-S	CW-1-LA
Black	B	Not Applicable
Smooth Black	B-S	CW-1-BL

For installation instructions, refer to the latest version of the infiNET Switches Installation Guide (Doc. 6293), which is available from the Crestron website.

Specifications

Following are specifications for the -SW1RF, -SW4RF, -SWS1RF, -SWS4RF, and -SLVS1RF.

CLW-SW1/4RF, CLW-SWS1/4RF, & CLW-SLVS1RF Specifications

SPECIFICATION	DETAILS
Power Requirements	Line Power, 120 VAC, 60 Hz
Operating Frequency	2400 MHz to 2483.6 MHz (802.15.4 compliant)
RF Output Power	10 mW
Operating Ranges ¹ Typical Distance Indoors (without repeater)	150 ft
Typical Distance Outdoors	250 ft, subject to site-specific conditions
Default MNET ID	-SW1RF/-SW4RF: 01/01 -SWS1RF/-SWS4RF: 01/01
Switch Type	Single-Pole, Single-Throw
Load Type	Incandescent, Tungsten-Halogen, Fluorescent / High Intensity Discharge (HID), Electronic Low Voltage, Magnetic Low Voltage, Neon / Cold Cathode, Ceiling Fan
2-Series Control System Update File ^{2,3}	Version 3.154 or later
Load Ratings ⁴ Incandescent / Tungsten- Halogen	-SW1RF/-SW4RF: 1000W -SWS1RF/-SWS4RF: 1000W -SLVS1RF: N/A
Magnetic Low Voltage ⁵	-SW1RF/-SW4RF: 1000VA/750W -SWS1RF/-SWS4RF: 1000VA/750W -SLVS1RF: N/A
Neon / Cold Cathode ⁵	-SW1RF/-SW4RF: 1000VA/750W -SWS1RF/-SWS4RF: 1000VA/750W -SLVS1RF: N/A
Electronic Low Voltage	-SW1RF/-SW4RF: 1000W -SWS1RF/-SWS4RF: 1000W -SLVS1RF: N/A
Ceiling Fan	-SW1RF/-SW4RF: 3A -SWS1RF/-SWS4RF: 3A -SLVS1RF: N/A
Minimum Load	40W / 0.5A
Operating Temperature and Humidity	32°F to 104°F (0°C to 40°C) 10 to 90% Relative Humidity (Non-Condensing)
Dimensions and Weight	-SW1RF/-SW4RF and -SWS1RF/-SWS4RF: Height: 4.13 in (10.48 cm) Width: 2.38 in (6.03 cm) Depth: 1.88 in (4.77 cm) Weight: 4.9 oz (0.67 kg)

(Continued on following page)

CLW-SW1/4RF, CLW-SWS1/4RF, & CLW-SLVS1RF Specifications (continued)

SPECIFICATION	DETAILS
Dimensions and Weight (continued)	-SLVS1RF: Height: 4.13 in (10.48 cm) Width: 1.75 in (4.45 cm) Depth: 1.88 in (4.77 cm) Weight: 3.6 oz (0.50 kg)

1. The range is dependent on its placement and the building in which it is used. The construction of the building, obstructions, and RF interference from other devices are factors determining the effective range of the unit.
2. The latest software versions can be obtained from the Crestron website. Refer to the NOTE following these footnotes.
3. Crestron 2-Series control systems include the AV2 and PRO2. Consult the latest Crestron Product Catalog for a complete list of 2-Series control systems.
4. Refer to Derating Charts for Multigang Installations in the latest version of the infiNET Switches Installation Guide (Doc. 6293) which is available from the Crestron website.
5. VA ratings are for input power to the transformer. If you do not know the input power requirement of the transformer, use the bulb's wattage rating to determine proper rating.

NOTE: Crestron software and any files on the website are for Authorized Crestron dealers and Crestron Authorized Independent Programmers (CAIP) only. New users may be required to register to obtain access to certain areas of the site (including the FTP site).

Physical Description

The -SW1RF and -SWS1RF have a light emitting diode (LED) with adjustable brightness (via Crestron programming software), a rocker button, and a three-position mode selection switch as shown in the following diagrams. The button may be pushed at the top or bottom to perform certain functions. Pushing the button in the middle does not do anything. The function of the pushbutton is determined by the position of the mode selection switch. For more information, refer to “Operation” on page 10.

Parts of CLW-SW1RF and -SWS1RF

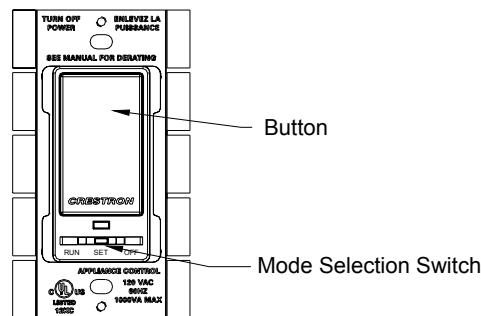

Physical View of CLW-SW1RF/-SWS1RF (Clockwise from Top; Top, Side, and Front)

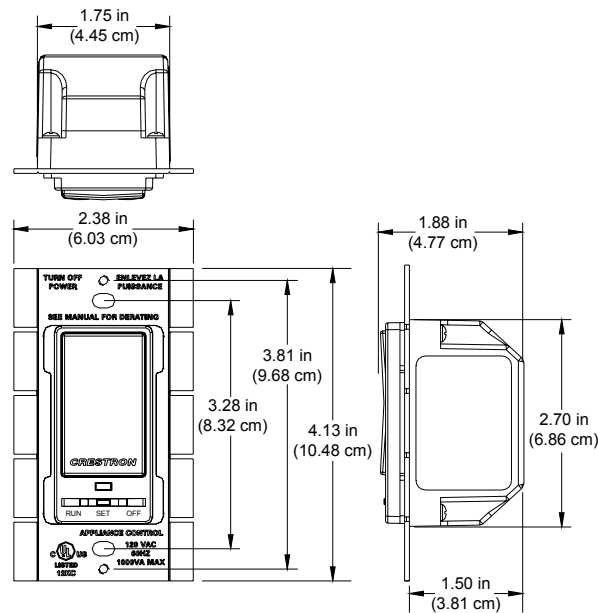

The -SW4RF and -SWS4RF have a light emitting diode (LED) with adjustable brightness (via Crestron programming software), four pushbuttons, and a three-position mode selection switch as shown in the following diagrams. Each of the buttons may be pushed to perform certain functions. The function of each pushbutton is determined by the position of the mode selection switch. For more information, refer to “Operation” on page 10.

Parts of CLW-SW4RF, -SWS4RF

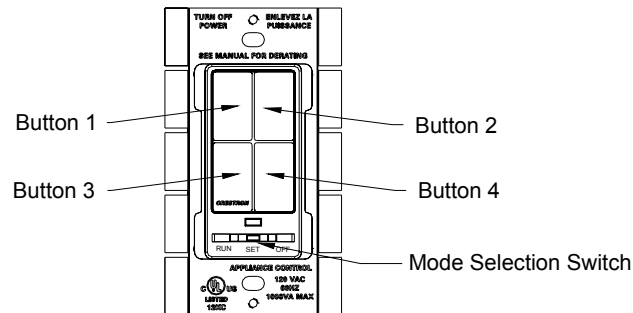

Physical View of CLW-SW4RF/-SWS4RF (Clockwise from Top; Top, Side, and Front)

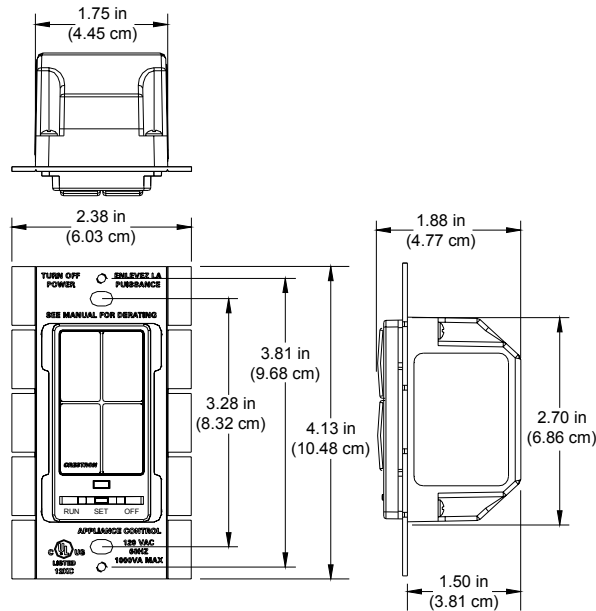

The -SLVS1RF is similar in appearance to the -SW1RF and -SWS1RF but does not have the three-position mode selection switch. The brightness of the LED on the -SLVS1RF is not programmable.

Physical View of CLW-SLVS1RF (Clockwise from Top; Top, Side, and Front)

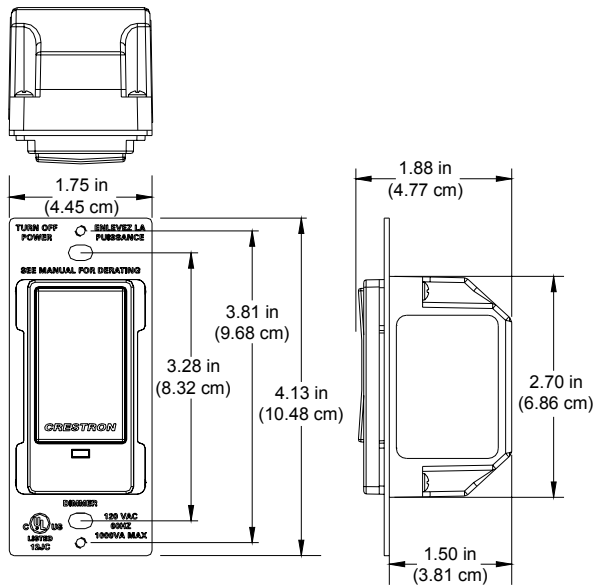

The -SW1RF, -SW4RF, -SWS1RF, -SWS4RF, and -SLVS1RF mount in a standard wallbox and are covered using a decorative faceplate (not included). All line voltage connections are made at the rear of the switch.

Left to Right, CLW-SW1RF/-SWS1RF, CLW-SW4RF/-SWS4RF, and CLW-SLVS1RF; Shown in White



Industry Compliance

This product is Listed to applicable UL Standards and requirements by Underwriters Laboratories Inc.



FCC ID: EROCWD1011

Compliance Statement (Part 15.19)

This device complies with Part 15 of the FCC Rules. Operation is subject to the following two conditions:

1. This device may not cause harmful interference and
2. This device must accept any interference received, including interference that may cause undesired operation.

Warning (Part 15.21)

Changes or modifications not expressly approved by the party responsible for compliance could void the user's authority to operate the equipment.

RF Exposure (OET Bulletin 65)

To comply with FCC's RF exposure limits for general population / uncontrolled exposure, this transmitter must be installed to provide a separation distance of at least 20 cm from all persons and must not be co-located or operating in conjunction with any other antenna or transmitter.

Industry Canada Statement

The term "IC" before the certification/registration number only signifies that the Industry Canada technical specifications were met
IC: 5683A- CWD1011

Acquire the Switch on the infiNET Network

Before an infiNET device can be used on an infiNET network, it must first be acquired to a C2N-MNETGW gateway that is connected to a Cresnet network.

NOTE: The -SW1RF, -SW4RF, -SWS1RF, and -SWS4RF can also work as stand-alone wall box switches without being acquired by a C2N-MNETGW.

NOTE: A switch can be acquired to only one gateway.

Acquire the Switch

To acquire a -SW1RF/-SW4RF/-SWS1RF/-SWS4RF to a C2N-MNETGW, perform the following:

1. Put the C2N-MNETGW in the *Acquire* mode, from the unit itself or from Crestron Toolbox, as described in the latest revision of the C2N-MNETGW Operations Guide (Doc. 6317) which is available from the Crestron website or the Crestron Toolbox help file.

NOTE: In an environment where multiple gateways are installed, only one gateway should be in the *Acquire* mode at a time.

2. Place the -SW1RF/-SW4RF/-SWS1RF/-SWS4RF into the *Acquire* mode by doing the following:
 - a. Move the mode selection switch (located under the LED) to the “OFF” position.
 - b. Press and hold the top or bottom of the button on the -SW1RF/-SWS1RF or any button on the -SW4RF/-SWS4RF.
 - c. While holding the button, slide the mode selection switch to the “RUN” position.
 - d. Hold the button for approximately five seconds until the LED flashes HIGH once. Immediately release the button after the LED blinks to start the switch’s *Acquire* mode.

NOTE: The LED can flash HIGH or LOW. Refer to “LED Behavior” on page 11 for more information.

NOTE: Holding the button for a significant time after the first flash may enter other modes. If this is not desired, return the mode selection switch to the “OFF” position without releasing the button and repeat step 2.

After approximately ten seconds, the LED will start to blink slowly and the switch will attempt to acquire with a C2N-MNETGW that is in the *Acquire* mode. The device is acquired when the LED stops blinking and lights at the LOW setting. After being acquired, the device will exit the *Acquire* mode.

The switch will be acquired on the C2N-MNETGW with an MNET ID value of 01. If the switch was previously acquired on another infiNET network, the switch will be acquired on the C2N-MNETGW with its previous MNET ID.

3. Take the C2N-MNETGW out of the *Acquire* mode once all devices have been acquired. Refer to the latest revision of the C2N-MNETGW Operations Guide (Doc. 6317), which is available from the Crestron website.

To communicate with the control system program, an MNET ID value between 03 and 20 must be assigned to the switch. For information on assigning MNET ID values, refer to “Identity Code” on page 13.

**Remove Gateway
Information from a
Switch**

In some rare cases, it might be desirable to release a switch from a gateway. If a switch is to be released from a gateway, the gateway information must be cleared from the switch’s memory.

To clear a switch’s gateway information:

1. Move the mode selection switch (located under the LED) to the “OFF” position.
2. Press and hold the top or bottom of the button on the -SW1RF/-SWS1RF or any button on the -SW4RF/-SWS4RF.
3. While holding the button, slide the mode selection switch to the “RUN” position.
4. Hold the button for approximately ten seconds until the LED flashes twice. Immediately release the button after the LED flashes twice to clear the switch’s gateway information. Reacquire the switch if desired.

A switch can also be released from a gateway using Toolbox. Refer to the latest revision of the C2N-MNETGW Operations Guide (Doc. 6317) or the Crestron Toolbox help file for instructions.

Operation

NOTE: The device may be warm to the touch during operation. This is normal.

Mode Selection Switch

These switches use a three-position mode selection switch to set the mode of operation.

- **OFF**

When the mode selection switch is in the “OFF” position, the pushbutton(s) will not have any function and the load is disconnected from the power source. This **must** be used when changing light bulbs to ensure that the load is fully disconnected from power. Slave devices that are connected to the switch will not have any function when the Master’s mode selection switch is in the “OFF” position.

- **RUN**

When the switch is in the “RUN” position, it is operating in the *RUN* mode. This is the normal operating mode of the switch. The *RUN* mode is used to turn the load on and off. If a delay time is set, the switch will turn off the load after the set delay time. For information on setting a delay time, refer to “SET” below.

Refer to the following table for a list of available functions when the switch is operating in the *RUN* mode.

NOTE: If the behavior of the -SW4RF/-SWS4RF has not been changed in SIMPL™ Windows®, SystemBuilder™ or D3 Pro™, the only button that will perform any function is Button 1. All of the other buttons are programmable.

RUN Mode Button Functions

FUNCTION	-SW1RF/ -SWS1RF/ -SLVS1RF BUTTON PRESS	-SW4RF/-SWS4RF BUTTON PRESS
Turn on load.	Tap the Top button.	Tap Button 1.
Turn off load with delay. ^{1,2}	Tap the Bottom button.	Tap Button 1.
Cancel delayed-off timer (if load was already on and timer was running).	Tap the Top button.	Tap Button 1.
Turn off load immediately	Double-tap the Bottom button.	Double-tap Button 1.

1. If delay is set to 0 seconds, the load will turn off immediately.
2. If the switch was in the middle of a delay, pressing the button will cancel the delay and turn off the load immediately

- **SET**

When the mode selection switch is in the “SET” position, it is operating in the *SET* mode. The LED will blink to indicate that the switch is in the *SET* mode. Refer to the following table for a list of available functions when the switch is operating in this mode.

NOTE: The *SET* mode is only intended for adjusting the delay time. Under normal operation, the mode selection switch should be in the “RUN” position.

SET Mode Button Functions

FUNCTION	-SW1RF/-SWS1RF BUTTON PRESS	-SW4RF/-SWS4RF BUTTON PRESS
Set the delay time to zero seconds.	Double-tap the Bottom button.	Double-tap the Button 1.
Set the delay time.*	Press and hold the Bottom button for the desired amount of delay. Upon release, the LED will flash to confirm.	Press and hold Button 1 for the desired amount of delay. Upon release, the LED will flash to confirm.

* The button must be held for longer than three seconds in order to set the time. Any shorter time will be ignored, and the time that was previously set will remain.

After setting the preset value(s), return the mode selection switch to the “RUN” position.

-SLVS1RF

The -SLVS1RF has one rocker button. The -SLVS1RF does not have a mode selection switch. It will emulate the RUN mode of the -SWS1RF (even if connected to a -SWS4RF) unless the mode selection switch of the master is set to “OFF”.

Restore Default Settings

To restore the switch’s default settings (delay time equal to zero seconds), move the mode selection switch to the “RUN” position. While holding the pushbutton (hold “UP” on the -SW1RF and -SWS1RF, or hold Button 1 on the -SW4RF or -SWS4RF), move the mode selection switch to the “SET” position and back to the “RUN” position. Release the pushbutton. The LED will flash once to confirm that the default values have been restored.

LED Behavior

The -SW1RF, -SWS1RF, -SW4RF, and the -SWS4RF have a single amber LED. Its behavior is determined by the current state of the switch or the control system program.

For reference, the LED can be in one of three intensity levels: OFF, LOW, and HIGH.

The following table describes the LED pattern in all modes of operation.

Switch Operation & LED Behavior

LED BEHAVIOR	DEVICE STATE
LOW	In <i>RUN</i> mode, operating normally
HIGH	Device is in the bootloader. Refer to “Bootloader” on page 29 for more information.
Four brief OFF blinks every eight seconds.	In <i>RUN</i> mode but there is no communication with a gateway. ¹
Four brief HIGH blinks every eight seconds.	Device failed to acquire with a gateway. ¹
Two brief OFF blinks every eight seconds.	In <i>RUN</i> mode, and communicating with a gateway, but the switch is not addressed in a control system program.
Blink OFF for ½ second, LOW for ½ second.	In <i>SET</i> mode.
Blink OFF for one second, HIGH for one second.	The switch is in the <i>Acquire</i> mode and searching for a gateway.
Blink OFF for ¼ second, HIGH for ¼ second.	In <i>Touch-setup</i> mode (refer to “Use Touch Settable ID (TSID) to Set MNET ID” on page 13) and waiting for the user to press a button to identify device. ²

1. Refer to “Acquire the Switch on the infiNET Network” on page 8.
2. Refer to the Crestron Toolbox help file.

Identity Code

Just like every device on a Cresnet system requires a unique identity code (NET ID), every device and user interface on the infiNET network requires a unique identity code (MNET ID). These codes are two-digit hexadecimal numbers from 03 to 20. The MNET ID of each unit must match an ID code specified in the SIMPL Windows program. Refer to “Programming with SIMPL Windows” on page 23 for details of the SIMPL Windows procedure.

The MNET ID of each infiNET device has been factory set to **01**. After an infiNET device is added to an infiNET network, its MNET ID must be changed to a value that can be addressed by the control system program (03 to 20). MNET IDs are changed from a personal computer (PC) via the Crestron Toolbox.

NOTE: For detailed information on establishing communication between the PC, control system, and the switch, refer to “Establishing Communication” on page 26. If communication cannot be established, refer to the “Troubleshooting Communications” section in the latest version of the 2-Series Control System Reference Guide (Doc. 6256), which is available from the Crestron website.

The Crestron Toolbox provides several methods to easily set or change device MNET IDs for any device on the infiNET network. MNET IDs can be set with the touch settable ID (TSID) function or manually. To use TSID to set MNET IDs, continue reading “Use Touch Settable ID (TSID) to Set MNET ID” below. To manually change MNET IDs, refer to “Manually Set MNET ID in Crestron Toolbox” on page 19.

Use Touch Settable ID (TSID) to Set MNET ID

Each infiNET device is shipped with the default MNET ID **01**. Since 01 is an MNET ID that cannot be addressed by the control system, the MNET ID of each infiNET device (except C2N-MNETRPT repeaters) must be changed to a value between 03 and 20.

Using Crestron Toolbox, the SIMPL Windows program file (*filename.smw*) can be used in conjunction with a device’s TSID feature to set MNET IDs of devices that were assigned IDs in a SIMPL Windows program.

Example:

A SIMPL Windows program was saved with the filename *infiNET.smw*. The program contains the following devices:

- (1) Crestron PRO2 control system
- (1) TPMC-15-CH touchpanel (NET ID 03)
- (1) C2N-MNETGW infiNET gateway (NET ID 0F)
- (2) CLW-DIM1RF infiNET dimmers (MNET IDs 03 and 0D)
- (1) CLW-SW1RF infiNET switch (MNET ID 04)

NOTE: For reference, one dimmer (MNET ID 03) is described in the example SIMPL Windows program as “BR Dimmer” and is located in a bedroom while the other dimmer (MNET ID 0D) is described as “LR Dimmer” and is located in the living room.

The infiNET switch and dimmers have already been acquired as described in the acquiring procedure described on page 8. The devices have been assigned the default MNET ID **01** as shown in the Network Device Tree window below.

Network Device Tree

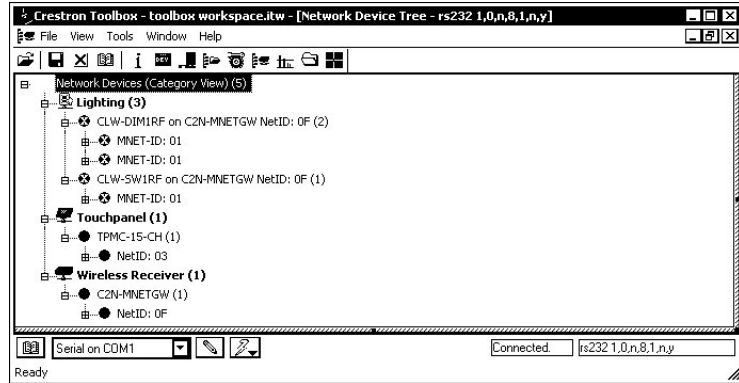

1. With the Network Device Tree open, select **Tools | SMW Program Tree**, or click .

SMW Program Tree-Click to Select Program

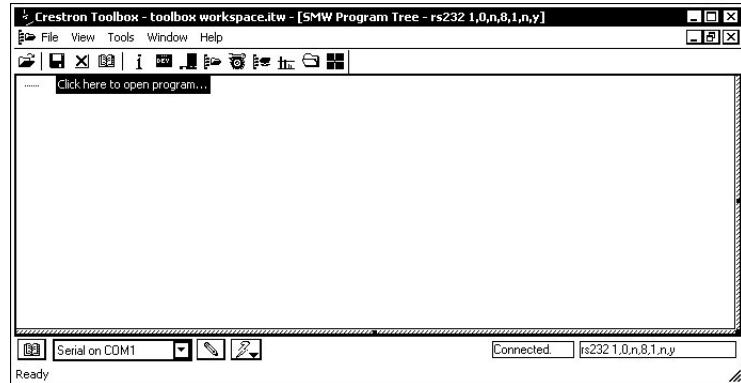

2. Click the text “Click here to open program...” to select the SIMPL Windows program that defines the MNET IDs.

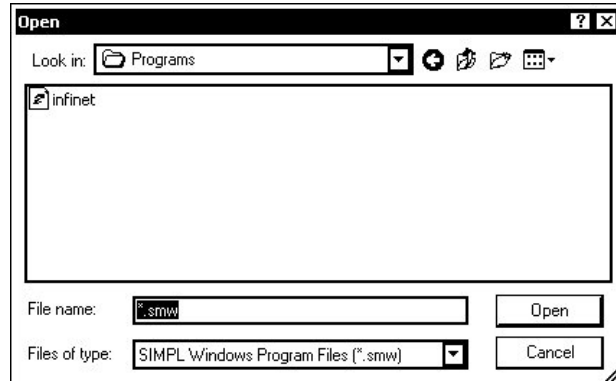

Select SIMPL Windows Program

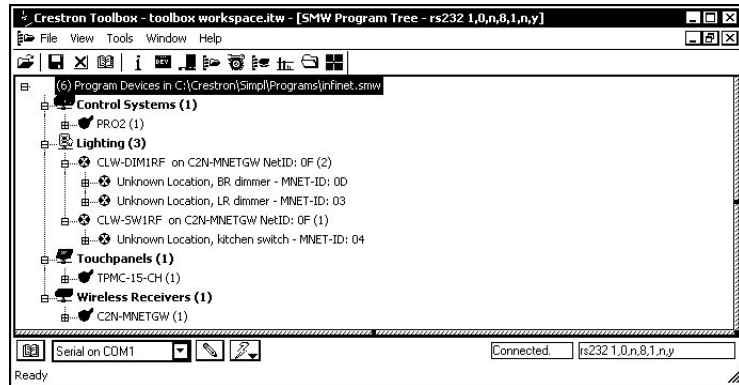

After selecting a file, SIMPL Windows will initialize and the SMW Program Tree will be displayed.

SMW Program Tree



Devices with NET IDs or MNET IDs that have been identified by the SMW Program Tree are marked with a  icon. Devices with NET IDs or MNET IDs that could not be identified are marked with a .

NOTE: Descriptions such as “BR Dimmer”, “LR Dimmer”, and “kitchen switch” were created by editing each devices symbol name in the SIMPL Windows Programming Manager. For information on editing a symbol name, refer to the SIMPL Windows help file.

3. Select **Window | Tile Horizontally** to tile the open windows in Crestron Toolbox. To simplify viewing, only the SMW Program Tree and the Network Device Tree described by the SMW Program Tree should be open.

Network Device Tree and SMW Program Tree Tiled in Crestron Toolbox

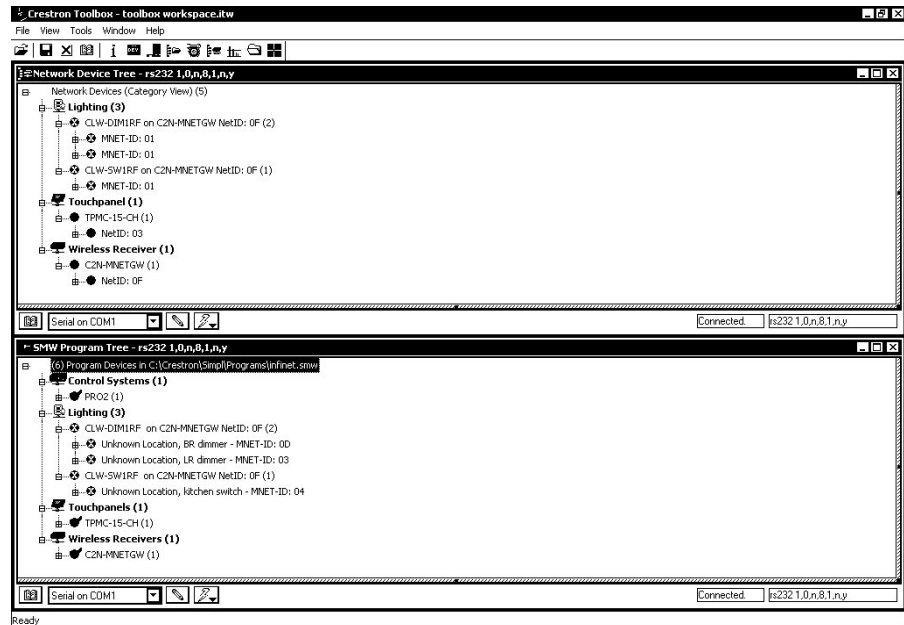

- In the SMW Program Tree, right-click on the top level of the tree and select **Link with Network Control**.

Link with Network Control

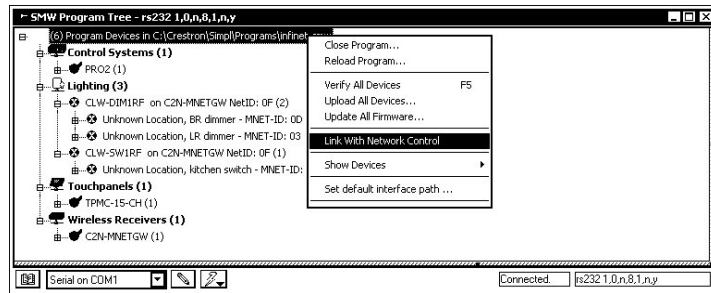

A window will be displayed with instructions for linking the SMW Program Tree to the Network Device Tree.

Link Instruction Window

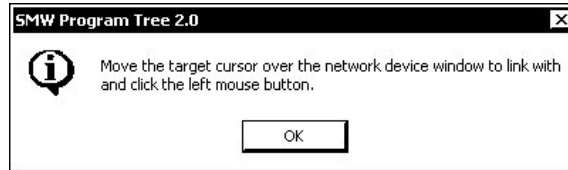

- Click **OK**. The cursor will change to a target selector (⊕).
- Click on the Network Device tree that is to be linked to the SMW Program Tree, A message will be displayed indicating a successful link.

Link Succeeded Message

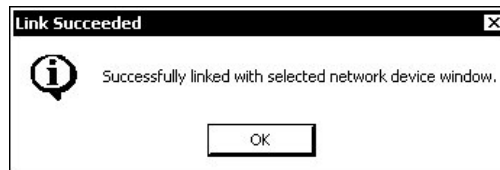

- Right-click the **Lighting** category in the SMW Device Tree and select **Setup All Lighting...**

“Setup All Lighting...”

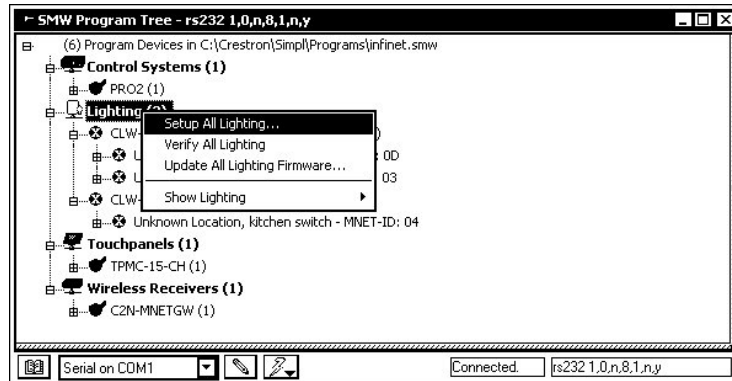

The “Setup Lighting” window will open and display a list of unidentified lighting devices.

Setup Lighting Window

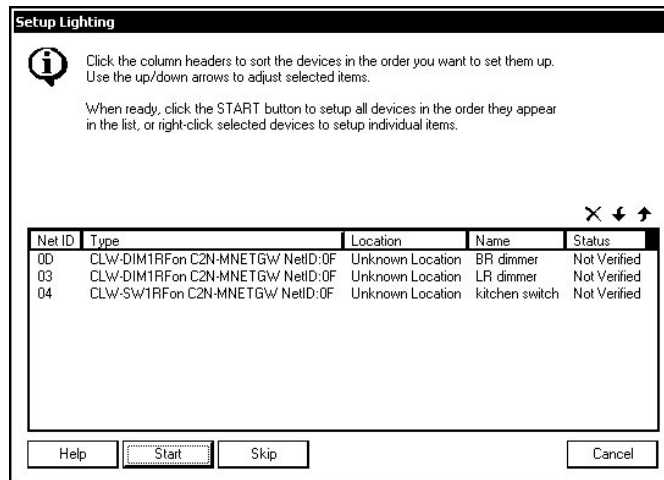

The listed devices can be sorted in ascending or descending order by clicking on the column headers. The order can also be adjusted by selecting a device and clicking the or buttons. This can be used when setting up devices in the order they will be encountered. For example, when identifying devices in a home, an installer may want to first identify a device by the entryway, then a device in the hallway, followed by devices in a room.

Devices that do not need to be identified can be removed from the list by clicking .

NOTE: Individual devices can be set up by right-clicking the device and selecting **Setup this device**. Follow the on-screen instructions to set up the device.

- Click **Start** to set up the devices in the order they appear on the list. The first item in the list (CLW-DIM1RF, MNET ID 00, “BR dimmer”) will be highlighted and the upper portion of the window will indicate the type of device.

CLW-DIM1RF Devices in Setup Mode Window; Identifying a Device

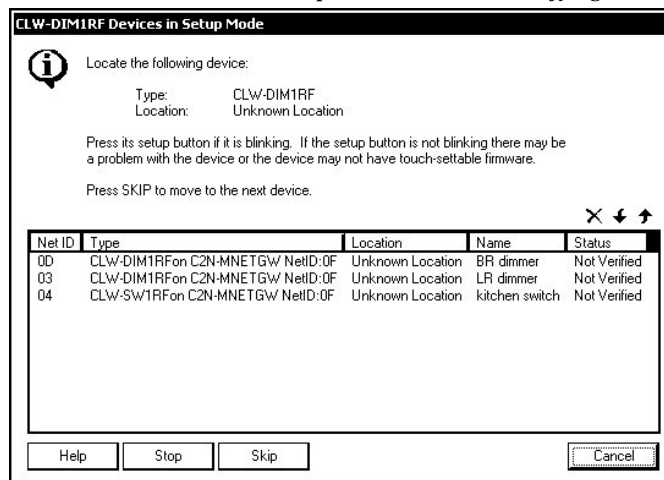

The LEDs on all of the CLW-DIM1RF dimmers on the list will flash.

- Physically locate the dimmer in the bedroom with the flashing LED and touch the top or bottom of the large button. The status of the “BR dimmer” will change from “Not Verified” to “Setup Complete” and the next device on the list (CLW-DIM1RF, MNET ID 03, “LR dimmer”) will be highlighted.

Touching a device may result in setting a duplicate MNET ID. A warning will be displayed.

Duplicate MNET ID Warning

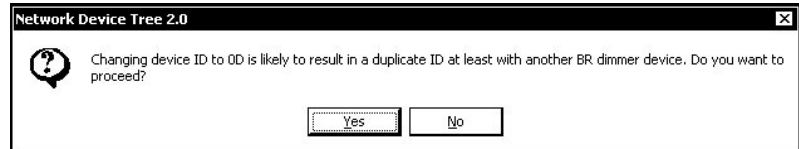

Click **Yes** to set the device to the duplicate MNET ID (the status will be listed with the comment “An error occurred changing the network ID of one or more devices.” Clicking **No** will skip the setup process for that device and continue to the next device on the list.

If two devices share a duplicate MNET ID, the devices with the duplicate MNET IDs must be set up again.

NOTE: If the device does not respond and/or register, click **Skip**.

Setup Lighting Window, Setup of First Device in List Completed

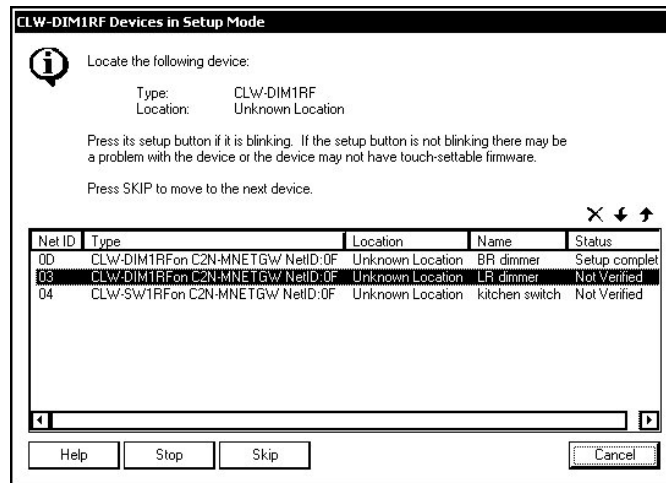

- Continue identifying all of the remaining unidentified devices on the list. When all devices have been identified, a summary will be displayed in the upper portion of the window.

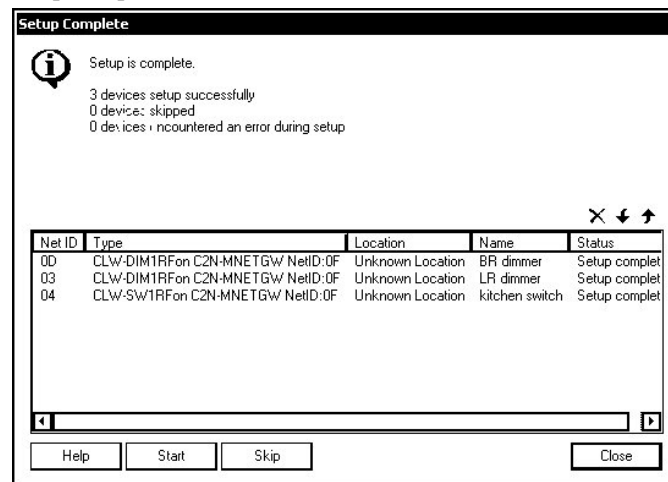
Setup Complete

- Click **Close** to close the window once all devices have been identified. All of the identified devices in the Network Device tree will be indicated with the  icon as shown in the following diagram.

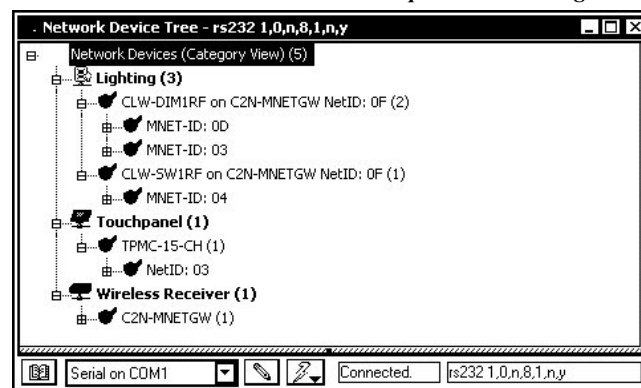
Network Device Tree with Devices Set Up with SMW Program Tree**Manually Set MNET ID in Crestron Toolbox**

The following method permits you to change the MNET ID of any infiNET device on the infiNET network through the “Network Device Tree” window.

This method does not change the MNET ID as assigned in SIMPL Windows. For information on setting the MNET ID in SIMPL Windows, refer to “Programming with SIMPL Windows” on page 23. If MNET IDs have already been assigned in a SIMPL Windows program, use the Touch Settable ID method described on page 13 to change the MNET ID to match the MNET ID specified in the SIMPL Windows program.

NOTE: You may also use D3 Pro or SystemBuilder to perform MNET ID setup. Refer to the respective help file for more information.

- Open Crestron Toolbox and establish communications with the control system (refer to “Establishing Communication” on page 26).

- Open the Network Device Tree and connect to the control system to verify that the gateway is connected to the control system and that all infiNET devices are acquired on the gateway. infiNET devices with MNET ID 01 will be shown with a  icon as shown in the following diagram.

“Network Device Tree” with Newly Added infiNET Device

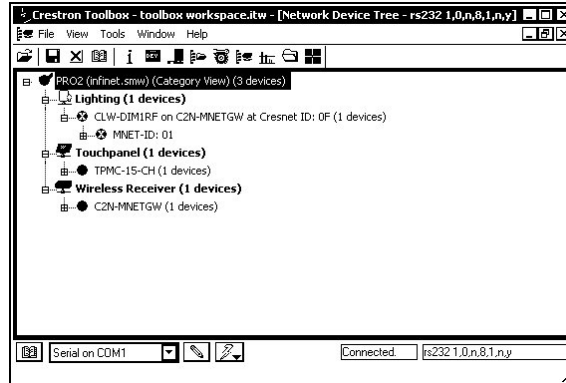

- Expand the device tree until the MNET ID that is to be changed is visible. Right-click on the MNET ID, and when the sub-menu appears, select **Change Network ID**.

“Network Device Tree” - Sub-Menu

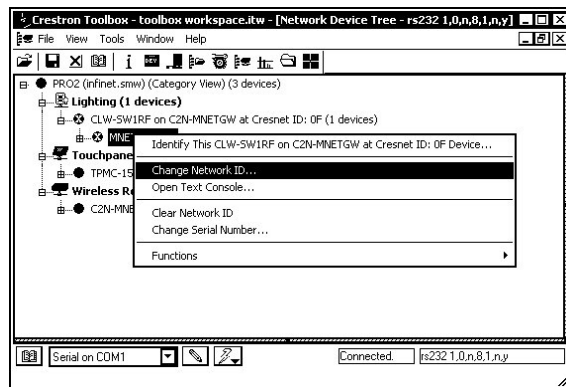

NOTE: Any infiNET switch in the Network Device Tree can be identified using Crestron Toolbox. Right-click a device in the Network Device Tree and select **“Identify this...”**. The LED on the switch will flash HIGH. Press a button on the switch to identify the device.

4. Select a new MNET ID and press **Enter**.

Enter New MNET ID

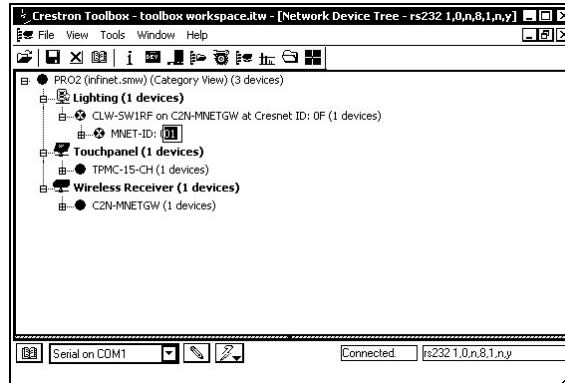

Repeat this procedure for each additional infiNET device requiring a MNET ID change.

WARNING: Devices with an MNET ID of 01 or 02 cannot be used in a control system program. These devices will be indicated with a  icon.

Programming Software

Have a question or comment about Crestron software?

Answers to frequently asked questions (FAQs) can be viewed in the Online Help section of the Crestron website. To post a question or view questions you have submitted to Crestron’s True Blue Support, log in at <http://support.crestron.com>. First-time users will need to establish a user account.

Earliest Version Software Requirements for the PC

NOTE: Crestron recommends that you use the latest software to take advantage of the most recently released features. The latest software is available from the Crestron website.

Crestron has developed an assortment of Windows®-based software tools to develop a controlled infiNET system. You can create a program to control the control system using the Crestron programming tools D3 Pro™ or SIMPL Windows. Customers whose focus is on lighting systems may prefer to use the D3 Pro software since it is designed especially for creating lighting and environmental system control applications. Customers already familiar with SIMPL Windows who are including a lighting system as part of an overall control system project may prefer to continue using SIMPL Windows. The following are the minimum recommended software versions for the PC:

Software

TASK	REQUIRED SOFTWARE VERSION
Program control system to operate infiNET switches.	SIMPL Windows version 2.06.20 or later with SIMPL+ Cross Compiler version 1.1 or later and Library update 352 or later. Also requires Crestron Database version 17.3.3 or later.
Upload program and firmware.	Crestron Toolbox 1.02.06 or later.
Program with simple wizards for lighting and environmental systems using infiNET switches (optional but recommended).	Crestron D3 Pro™ version 2.0 or later (requires SIMPL Windows, VisionTools Pro-e, Crestron Database and Crestron Engraver) with D3 Pro Templates version 1.0 or later. Refer to software release notes or Crestron website for other required Crestron software packages.
Program with simple wizards for systems using infiNET switches (optional but recommended).	Crestron SystemBuilder™ version 2.0 or later (requires SIMPL Windows, VisionTools Pro-e, Crestron Database and Crestron Engraver) with Systembuilder Templates version 2.01 or later. Refer to software release notes or Crestron website for other required Crestron software packages.

Programming with D3 Pro

Crestron's D3 Pro lighting software provides all the tools necessary to create a complete Crestron lighting system for residential applications. The lighting system includes the control system logic program, touchpanel projects and keypad programming, documentation and real-time lighting adjustment capabilities.

As with all Crestron software, D3 Pro provides extensive right-click and drag-and-drop functionality in addition to convenient keyboard shortcuts for frequently used functions and commands.

Programming is organized into six system **Views** of the lighting system, each providing a moveable toolbox of devices such as interfaces, fixtures and control modules. You can add a device to your system simply by selecting it from one of the toolboxes and dragging it to a room. The available toolboxes differ depending on the View but all Views include a "General" toolbox that allows you to add areas and rooms at any time.

Programming with SIMPL Windows

NOTE: While SIMPL Windows can be used to program an infiNET switch, it is recommended to use D3 Pro software for configuring an infiNET system.

SIMPL Windows is Crestron's premier software for programming Crestron control systems. It is organized into two separate but equally important "Managers".

Configuration Manager

Configuration Manager is the view where programmers "build" a Crestron control system by selecting hardware from the *Device Library*.

NOTE: Before adding an infiNET switch to a system, a C2N-MNETGW must first be added.

- To incorporate an infiNET switch into the system, drag a C2N-MNETGW from the Wireless Receivers |Wireless Receivers (RF) folder of the *Device Library* and drop it in the *System Views*. Refer to the latest version of the C2N-MNETGW Operations Guide (Doc. 6317) which can be downloaded from the Crestron website.
- To add infiNET devices to the C2N-MNETGW, right click on the C2N-MNETGW, select **Add item to: "C2N-MNETGW"** and select an infiNET device as shown in the following diagram.

Adding an infiNET Device to the C2N-MNETGW

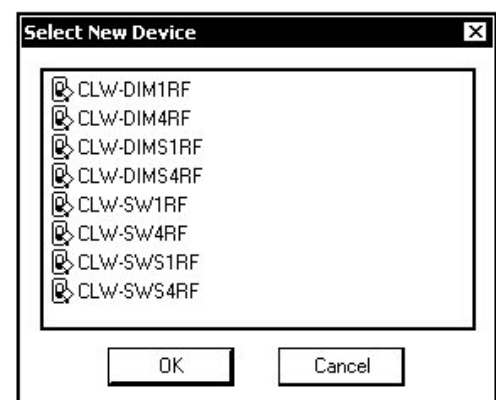
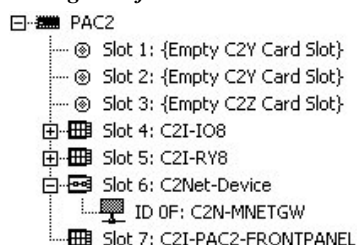

- The system tree of the control system displays the device in the appropriate slot with a default MNET ID as shown in the following illustration.

C2Net Device, Slot 6, with infiNET Device

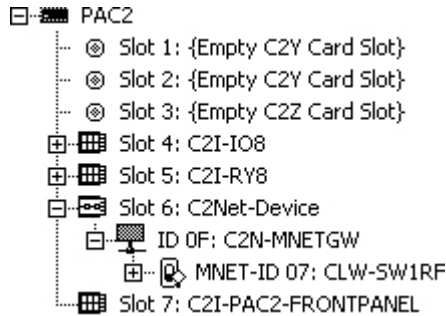

SIMPL Windows adds the selected infiNET device with a default MNET ID. Following are the default MNET IDs used by SIMPL Windows for each of the switch models:

- CLW-SW1RF: 07
- CLW-SW4RF: 09
- CLW-SWS1RF: 08
- CLW-SWS4RF: 0A

NOTE: The default MNET ID used by SIMPL Windows is different from the default ID that is installed on an infiNET device when it ships from the factory.

NOTE: If the default MNET ID is already in use, SIMPL Windows will assign the next available MNET ID.

NOTE: infiNET repeaters such as the C2N-MNETRPT are not added in SIMPL Windows as there is no control communication between a control system and a repeater.

- If necessary, double click a device to open the “Device Settings” window and change the MNET ID, as shown in the following figure.

“Device Settings” Window for the CLW-SW1RF

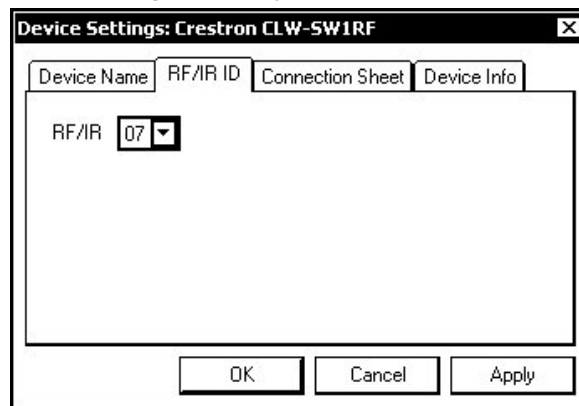

- The MNET ID specified in the SIMPL Windows program must match the MNET ID of each unit. Refer to “Identity Code” on page 13.

Program Manager

Program Manager is the view where programmers “program” a Crestron control system by assigning signals to symbols.

The symbol can be viewed by double clicking on the icon or dragging it into *Detail View*. Each signal in the symbol is described in the SIMPL Windows help file (F1).

Example Program

An example program for infiNET switch is available from the Crestron website (www.crestron.com/exampleprograms).

Uploading and Upgrading

Crestron recommends using the latest programming software and that each device contains the latest firmware to take advantage of the most recently released features. However, before attempting to upload or upgrade it is necessary to establish communication. Once communication has been established, files (for example, programs or firmware) can be transferred to the control system (and/or device). Finally, program checks can be performed (such as changing the device ID) to ensure proper functioning.

Establishing Communication

Use Crestron Toolbox for communicating with an infiNET switch; refer to the Crestron Toolbox help file for details. There is a single method of communication: indirect communication.

Indirect Communication

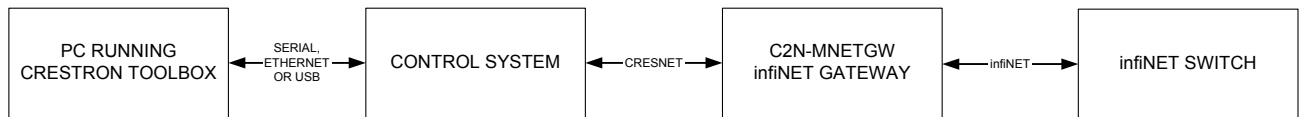

- infiNET switches connect to control system via infiNET using a C2N-MNETGW infiNET Gateway.
- Establish communication between the PC and the control system as described in the latest version of the 2-Series Control Systems Reference Guide (Doc. 6256).
- Use the Address Book in Crestron Toolbox to create an entry for the infiNET switch using the expected communication protocol (Indirect). Select the MNET ID of the infiNET switch and the address book entry of the C2N-MNETGW that is connected to the infiNET switch.
- Display the infiNET switch’s “System Info” window (click the  icon); communications are confirmed when the device information is displayed.

Programs and Firmware

Program or firmware files may be distributed from programmers to installers or from Crestron to dealers. Firmware upgrades are available from the Crestron website as new features are developed after product releases. One has the option to upload programs via the programming software or to upload and upgrade via the Crestron Toolbox. For details on uploading and upgrading, refer to the SIMPL Windows help file or the Crestron Toolbox help file.

SIMPL Windows

If a SIMPL Windows program is provided, it can be uploaded to the control system using SIMPL Windows or Crestron Toolbox.

Firmware

Check the Crestron website to find the latest firmware. (New users may be required to register to obtain access to certain areas of the site, including the FTP site.)

Upgrade the infiNET device's firmware via Crestron Toolbox.

- Establish communication with the infiNET device and display the “System Info” window.
- Select **Functions | Firmware...** to upgrade the infiNET device's firmware.

Program Checks

Right-click on the infiNET device to display other actions that can be performed on the infiNET device.

Problem Solving

Troubleshooting

The table after this paragraph provides corrective action for possible trouble situations. If further assistance is required, please contact a Crestron customer service representative.

infiNET Switch Troubleshooting

TROUBLE	POSSIBLE CAUSE(S)	CORRECTIVE ACTION
Switch does not function.	Switch is not receiving line power.	Verify that the switch is properly connected to the power lines and that the circuit breaker is closed.
	Load is not connected.	Verify that the load is operational and that the mode selection switch is in the "RUN" or "SET" position.
	Mode selection switch is in the "SET" position.	Move mode selection switch to the "RUN" position.
Switch does not respond to control system commands.	If the LED flashes OFF for ¼ second four times, then returns to low every eight seconds, the switch is not acquired on infiNET network.	Use the Network Device Tree infiNET network in Crestron Toolbox to poll the infiNET network. Acquire the device on infiNET network as described in "Acquire the Switch on the infiNET Network" on page 8.
	If the LED flashes OFF for ¼ second two times, then returns to low, the MNET ID of device is not set to match the MNET ID of the SIMPL Windows program.	Use the Network Device Tree infiNET network in Crestron Toolbox to poll the infiNET network. Verify that the MNET ID for the infiNET device is set to match the MNET ID specified in the SIMPL Windows program.
	If the LED flashes OFF for ¼ second four times, then returns to low every eight seconds, the C2N-MNETGW is not transmitting data to the infiNET device.	Open Crestron Toolbox and select the Network Device tree. Expand the network device tree until the gateway to be managed is selected. Right-click the Net ID of the selected gateway to open the sub-menu and select Functions MNET Gateway... If devices are not listed, acquire the device on to the infiNET network as described in "Acquire the Switch on the infiNET Network" on page 8.

(continued on following page)

infiNET Switch Troubleshooting (continued)

TROUBLE	POSSIBLE CAUSE(S)	CORRECTIVE ACTION
Switch presses are not reported to control system.	If the LED flashes OFF for ¼ second two times, then returns to low, the MNET ID of device is not set to match the MNET ID of the SIMPL Windows program.	Using Crestron Toolbox, poll the network. Verify that the MNET ID for the infiNET device is set to match the MNET ID specified in the SIMPL Windows program.
	If the LED flashes OFF for ¼ second four times, then returns to low every eight seconds, the infiNET device is not transmitting data to the C2N-MNETGW.	Open Crestron Toolbox and select the Network Device tree. Expand the network device tree until the gateway to be managed is selected. Right-click the Net ID of the selected gateway to open the sub-menu and select Functions MNET Gateway.... If devices are not listed, add devices by putting the C2N-MNETGW and infiNET device in <i>Acquire</i> mode.
	Switch is attached to load and the signal Enable_Local_Btn_Outputs is low.	In the switch symbol of the SIMPL Windows program, set the signal Enable_Local_Btn_Outputs high. Refer to the SIMPL Windows help file for more information.
Switch does not operate as described in the manual.	Switch is detached from the load.	In the switch symbol of the SIMPL Windows program, set the signal Detach_Load low. Refer to the SIMPL Windows help file for more information.
Delay time will not store.	Mode selection switch is in the incorrect position.	Set the mode selection switch to the “SET” position to store the delay time.
Cannot turn the load on or off.	Mode selection switch is in the incorrect position.	Set the mode selection switch to the “RUN” position to turn the load on or off.
Slave device does not emulate the <i>RUN</i> mode of the -SWS1RF (even when connected to -SWS4RF).	-SLVS1RF is detached from the load.	Set the signal Detach_Load_From_Slave low. Refer to the SIMPL Windows help file for more information.

Bootloader

In rare cases, it may be necessary to bypass the switch’s standard firmware and enter into the “bootloader”. This might be necessary if the unit was loaded with a faulty version of firmware that might prevent future firmware upgrades.

To enter the bootloader, set the mode selection switch to “OFF”. Press and hold the up button (or Button 1 on the -SW4RF or -SWS4RF) while setting the mode selection switch to “RUN”. The LED will blink once after five seconds to indicate the start of *Acquire* mode (*Acquire* mode does not actually start until you release the button). Continue holding the button for another five seconds, and the LED will flash twice to indicate that the gateway connection will be released on the release of the button. Continue holding the button an additional ten seconds (20 seconds in all) until the LED flashes three times and release the button. The unit is now running the bootloader. New firmware can now be uploaded from Crestron Toolbox.

To exit the bootloader and restore the firmware that is currently installed, cycle power to the device by setting the mode selection switch to “OFF” and back to “RUN” or “SET”.

Reference Documents

The latest version of all documents mentioned within the guide can be obtained from the Crestron website (www.crestron.com/manuals). This link will provide a list of product manuals arranged in alphabetical order by model number.

List of Related Reference Documents

DOCUMENT TITLE
2-Series Control Systems Reference Guide
C2N-MNETGW Operations Guide
infiNET Switches Installation Guide

Further Inquiries

If you cannot locate specific information or have questions after reviewing this guide, please take advantage of Crestron's award winning customer service team by calling the Crestron corporate headquarters at 1-888-CRESTRON [1-888-273-7876]. For assistance in your local time zone, refer to the Crestron website (<http://www.crestron.com/offices>) for a listing of Crestron worldwide offices.

You can also log onto the online help section of the Crestron website (<http://www.crestron.com/onlinehelp>) to ask questions about Crestron products. First-time users will need to establish a user account to fully benefit from all available features.

Future Updates

As Crestron improves functions, adds new features, and extends the capabilities of the device, additional information may be made available as manual updates. These updates are solely electronic and serve as intermediary supplements prior to the release of a complete technical documentation revision.

Check the Crestron website periodically for manual update availability and its relevance. Updates are identified as an “Addendum” in the Download column.

Return and Warranty Policies

Merchandise Returns / Repair Service

1. No merchandise may be returned for credit, exchange or service without prior authorization from CRESTRON. To obtain warranty service for CRESTRON products, contact an authorized CRESTRON dealer. Only authorized CRESTRON dealers may contact the factory and request an RMA (Return Merchandise Authorization) number. Enclose a note specifying the nature of the problem, name and phone number of contact person, RMA number and return address.
2. Products may be returned for credit, exchange or service with a CRESTRON Return Merchandise Authorization (RMA) number. Authorized returns must be shipped freight prepaid to CRESTRON, 6 Volvo Drive, Rockleigh, N.J. or its authorized subsidiaries, with RMA number clearly marked on the outside of all cartons. Shipments arriving freight collect or without an RMA number shall be subject to refusal. CRESTRON reserves the right in its sole and absolute discretion to charge a 15% restocking fee plus shipping costs on any products returned with an RMA.
3. Return freight charges following repair of items under warranty shall be paid by CRESTRON, shipping by standard ground carrier. In the event repairs are found to be non-warranty, return freight costs shall be paid by the purchaser.

CRESTRON Limited Warranty

CRESTRON ELECTRONICS, Inc. warrants its products to be free from manufacturing defects in materials and workmanship under normal use for a period of three (3) years from the date of purchase from CRESTRON, with the following exceptions: disk drives and any other moving or rotating mechanical parts, pan/tilt heads and power supplies are covered for a period of one (1) year; touchscreen display and overlay components are covered for 90 days; batteries and incandescent lamps are not covered.

This warranty extends to products purchased directly from CRESTRON or an authorized CRESTRON dealer. Purchasers should inquire of the dealer regarding the nature and extent of the dealer's warranty, if any.

CRESTRON shall not be liable to honor the terms of this warranty if the product has been used in any application other than that for which it was intended or if it has been subjected to misuse, accidental damage, modification or improper installation procedures. Furthermore, this warranty does not cover any product that has had the serial number altered, defaced or removed.

This warranty shall be the sole and exclusive remedy to the original purchaser. In no event shall CRESTRON be liable for incidental or consequential damages of any kind (property or economic damages inclusive) arising from the sale or use of this equipment. CRESTRON is not liable for any claim made by a third party or made by the purchaser for a third party.

CRESTRON shall, at its option, repair or replace any product found defective, without charge for parts or labor. Repaired or replaced equipment and parts supplied under this warranty shall be covered only by the unexpired portion of the warranty.

Except as expressly set forth in this warranty, CRESTRON makes no other warranties, expressed or implied, nor authorizes any other party to offer any warranty, including any implied warranties of merchantability or fitness for a particular purpose. Any implied warranties that may be imposed by law are limited to the terms of this limited warranty. This warranty statement supersedes all previous warranties.

Trademark Information

All brand names, product names and trademarks are the sole property of their respective owners. Windows is a registered trademark of Microsoft Corporation. Windows95/98/Me/XP/Vista and WindowsNT/2000 are trademarks of Microsoft Corporation.



Crestron Electronics, Inc.
15 Volvo Drive Rockleigh, NJ 07647
Tel: 888.CRESTRON
Fax: 201.767.7576
www.crestron.com

Operations Guide – DOC. 6397A
(2014134)
10.07
Specifications subject to
change without notice.