

Skyline™ Air Handler

Group: **Applied Air Systems**

Part Number: **IM 777**

Date: **November 2011**

Models OAC/OAH 003G – 090G



Introduction	3	Operation Guidelines	19
General Information	3	Startup Checks	19
Receiving and Handling	3	Before Starting the Unit	19
Nomenclature	3	VFD Setup	20
Unit Storage	4	Fan Startup	20
Mechanical Installation	5	Fan Wheel Alignment	20
Service Clearances	5	Operating Limits	23
Rigging	5	Fan Vibration Levels	24
Curb Mounting and Unit Leveling	5	Vibration Causes	24
Assembling Sections	6	Service and Maintenance	25
Shipping Sections	6	Periodic Maintenance	25
Panels, Frame Channels, and Doors	8	Ball Bearing Lubrication	25
Panel Removal	8	Motor Bearings	25
Frame Channel Removal	8	Fan Shaft Bearings	25
Access Doors and Panels	8	Fan Drive	26
Fan Section Doors	8	VM and VP Variable Pitch Key Type Sheaves	26
Injected-Foam Insulated Panels	9	LVP Variable Speed Sheaves	27
Field Mounting Junction Boxes and		MVP Variable Speed Sheaves	28
Other Components	9	Fan Drive Belt Adjustment	30
Duct Connections	9	Front Load Filter Option	31
Dampers and Hoods	10	Filter Gauges	31
Mounting Actuators	10	Coils	32
Face and Bypass Section Mounting	11	Winterizing Water Coils	32
Isolation Dampers for Multiple Fans	11	Removing and Replacing Components	32
Piping Vestibules	11	Removing the Fan Section	32
Piping and Coils	11	Parts	35
Water Cooling Coils	11	Replacement Parts	35
Direct Expansion Coils	12	Service and Warranty Procedure	36
Steam Coils	12	Warranty	36
Water Heating Coils	14	Warranty Return Material Procedure	36
Drain Pan Traps	14	Check, Test, and Start Procedure Form	37
Internal Isolation Assembly Adjustment	15	Quality Assurance Survey Report	39
Electrical Installation	17		
Wiring	17		

General Information

The system design and installation must follow accepted industry practice as described in the ASHRAE Handbook, the National Electric Code, and other applicable standards. Install this equipment in accordance with regulations of authorities having jurisdiction and all applicable codes.

Installation and maintenance must be performed by qualified personnel familiar with applicable codes and regulations and experienced with this type of equipment. Sheet metal parts, self-tapping screws, fins, clips, and such items inherently have sharp edges; the installer should exercise caution.



CAUTION

Sharp edges and coil surfaces are a potential injury hazard. Avoid contact with them.



ATTENTION

Les bords tranchants et les surfaces des bobines sont un risque de blessure. Ne les touchez pas.

Nomenclature

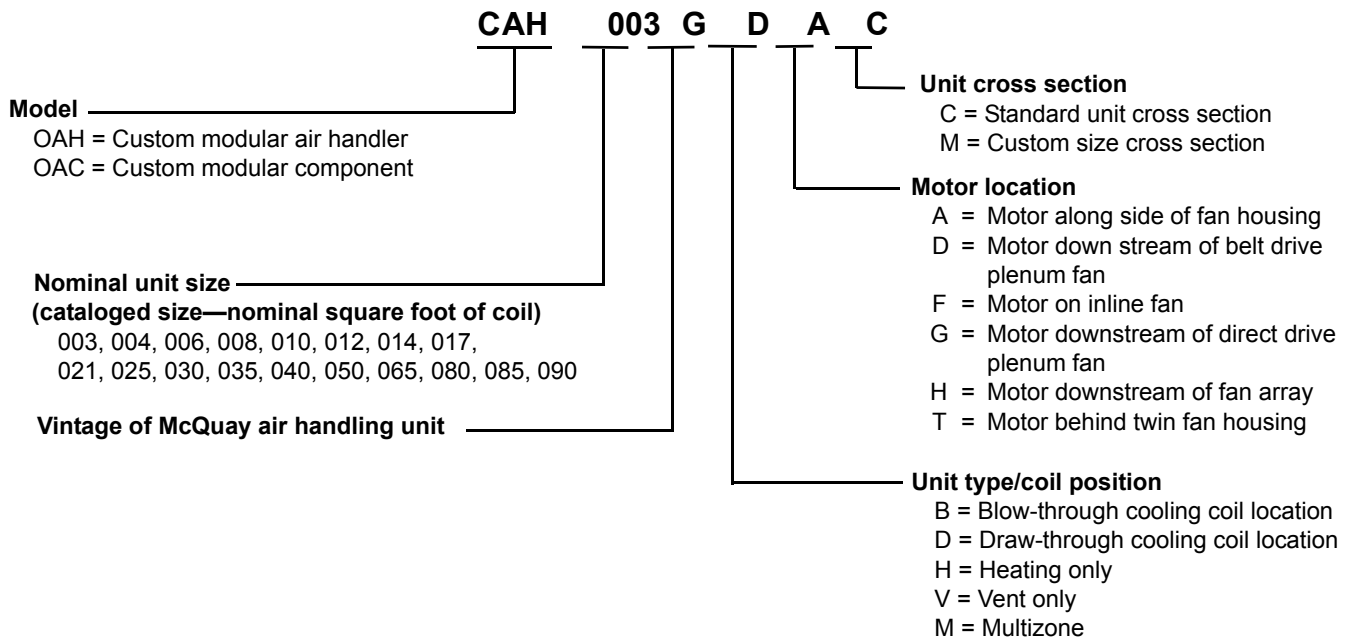

Receiving and Handling

- 1 Carefully check items against the bills of lading to verify all crates and cartons have been received. Carefully inspect all units for shipping damage. Report damage immediately to the carrier and file a claim.
- 2 Skyline air handler units are constructed of galvanized or painted steel and are inspected thoroughly before leaving the factory. Take care during installation to prevent damage to units.
- 3 Take special care when handling the blower section. All fans are dynamically balanced before leaving the factory. Rough handling can cause misalignment or a damaged bearings or shaft. Carefully inspect fans and shaft before unit installation to verify this has not happened.

Note: Screws, bolts, etc., for assembling sections are supplied in a bag attached to each section. All necessary gasketing is applied in the factory for section-to-section mounting, unless the unit has a curb ready base. Units require caulk sealant between sections.

Introduction

Unit Storage

- Store on a level surface in a clean, dry location where temperature can be controlled if possible.
- Pack fan and motor bearings (unless motor bearings are sealed) with compatible grease with the shaft stationary. After grease has been installed, rotate shaft about 10 rotations.
- Isolate unit from shock and vibration.
- Once a month, rotate shaft a minimum of 10 revolutions. Insure the stopped position is different than the original position.
- Coat shafts with lubricant as needed to prevent corrosion.
- A desiccant bag may be hung in the interior of the unit to minimize corrosion in humid storage environments.
- Do not clean galvanized steel surfaces with oil dissolving chemicals. This may remove the protective coating and accelerate corrosion.
- Do not allow coverings to trap moisture on galvanized surfaces.

Belt driven fans:

- Reduce belt tension by at least 50% or remove the belts. Remove belts if they will be subjected to temperatures exceeding 85° F to avoid deterioration.
 - Remove belt guard when adjusting belts
 - Reduce belt tension prior to removing or installing belts. Removing or installing tensioned belts may cause personal injury and damage to the sheaves, belts, bearings or shafts.
- Adjustable sheaves should be opened as wide as possible and the adjustment threads lubricated so they do not corrode. Be careful not to put lubricant on the belt running surface

Prior to start up:

- Set screws on bearings, fan wheels, and sheaves need to be checked for proper torque. Also check bolt torque for any taper lock hubs either on the wheel or sheaves.
- Check sheaves for corrosion. Significant corrosion can cause belt or sheave failure.
- Purge old grease from fan bearings while rotating the shaft to distribute the new grease evenly and prevent bearing seal failure.
- Correctly align and tension belts. See [General Rules of Tensioning, page 30](#).

Service Clearances

In addition to providing adequate space around the unit for piping coils and drains, access to at least one side of the unit is always required to allow for regular service and routine maintenance, which includes filter replacement, drain pan inspection and cleaning, fan bearing lubrication, and belt adjustment. Provide sufficient space—at least equal to the length of the coil—on the side of the unit for coil removal. See [Figure 1](#) for servicing space requirements.

Maintain at least 54" of clearance in front of electrical power devices. Electrical power devices that are mounted on the side of the unit typically are up to 12" deep ([Figure 2](#)). Fan sections with multiple fans have motor control boxes up to 16" deep when supplied with VFDs.

Figure 1: Servicing Space Requirements

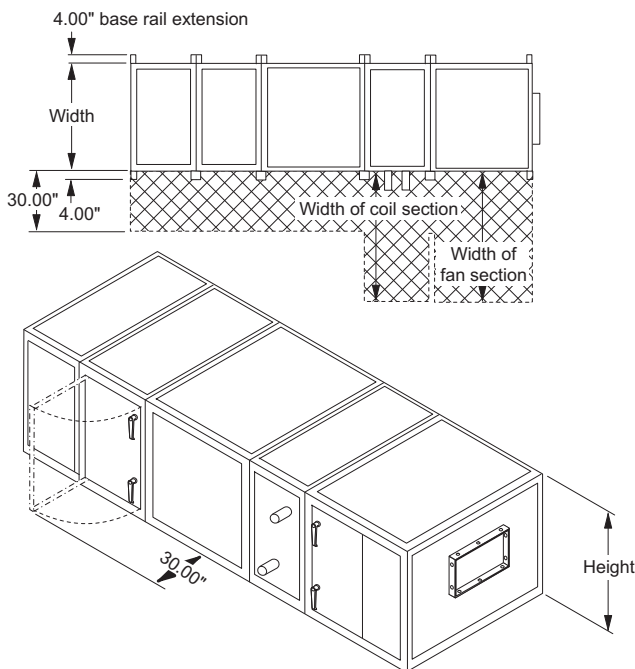
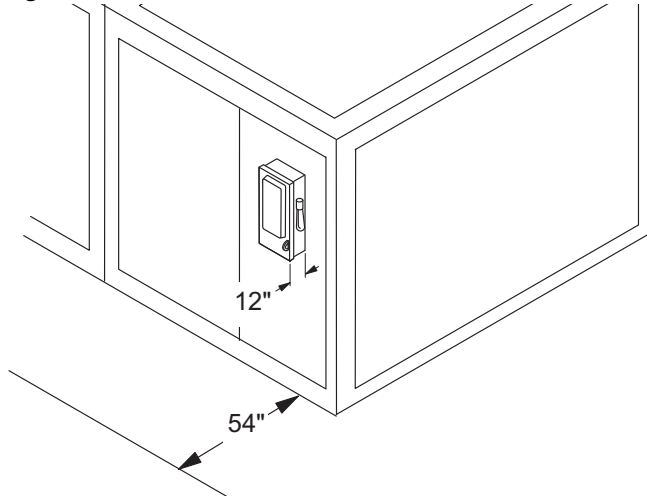

Figure 2: Service Clearance for Electrical Power Devices



Rigging

Skyline air handlers ship as separate sections, completely assembled, or in modules of assembled sections. **The unit must be rigged as it ships from the factory. Do not rig units after assembly.** Units are provided with a factory-installed base rail and can be lifted using the 2" diameter lifting holes located in the corners of each shipping section. To prevent damage to the unit cabinetry, use spreader bars. Position spreader bars to prevent cables from rubbing the frame or panels. Before hoisting into position, test lift for stability and balance. Avoid twisting or uneven lifting of unit.

Figure 3: Unit and Section Rigging

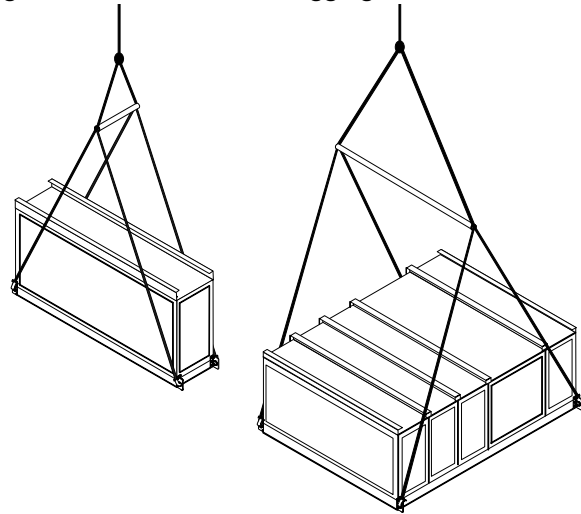

Curb Mounting and Unit Leveling

Do not place a Skyline unit over an open curb unless it is equipped with a curb-ready base. Installation instructions for mounting units on a roof curb are provided in IM 770. For a copy, contact your local McQuay representative or visit www.mcquay.com. Make provisions under the unit to divert any moisture from entering the building below.

For units without roof curb mounting, place the equipment on a flat and level surface. Where surface irregularities exist, shim the base of the unit at one or more points along the length of the rails to prevent distortion or sagging of the support rails. Uneven or distorted sections cause misfit or binding of the doors and panels and improper draining of drain pans ([Figure 4](#)).

Mechanical Installation

If the unit is supported on rails they must be placed around the entire perimeter. Additional Supports must be placed perpendicular to airflow spanning the full width of the unit at all shipping splits. If the unit is over 107" wide these supports must also be placed at the entering and leaving edges of fan and cooling coil sections. The perimeter rails must be at least 2" wide at the top and capable of carrying the entire weight of the unit. The cross supports must be 4" wide at the top and capable of carrying the weight of the two sections it spans. The cross supports shall be placed such that 2" of the top is supporting each section. The perimeter rails shall be placed so that they are fully supporting the outer 2" of the unit. If shims are required they must be placed such that the unit is fully supported.

Figure 4: Leveling the Unit

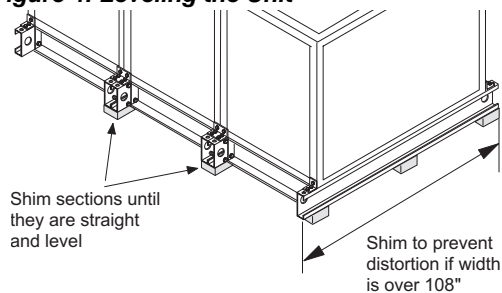

Assembling Sections

If the unit is shipped in more than one shipping section, rig each section into position separately. Shipping sections are provided with a connection splice joint attached on the leaving air side of the shipping section that seals against the frame channel on the entering-air side of the adjoining. The splice joint is insulated and provides an air-tight seal between two sections once they are assembled together. Align the splice joint to seat into the mating gasket to provide an air seal. If the splice joint was bent during shipping or rigging, restore it to its original position (Figure 9). For Skyline Plus units, ensure that the D-gasket is attached to the entering air side frame channel (Figure 7 and Figure 10). If it dislodged during shipping, restore it to its designed position.

Shipping Sections

- 1 Caulk all assembly joints of the unit—Before joining the sections, apply at least 1/4 inch diameter bead of sealant to the mating faces of the cabinet. Use the splice joint as a guide for applying the sealant (Figure 5).

Figure 5: Apply Sealant to Mating Faces

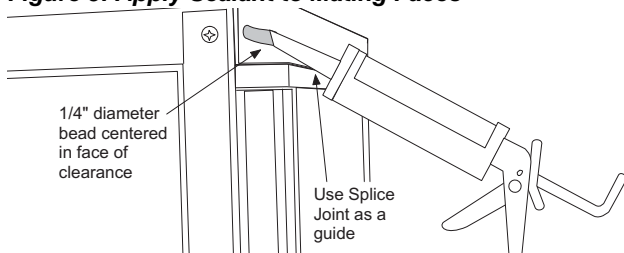

- 2 Pull sections together to fasten. Use straps and a ratchet to help pull the sections together securely. Apply sealant to any gaps that may admit moisture.

- 3 Fasten base rails together first using the 3/8"-16 x 5" bolts located in the splice kit provided with the unit (Figure 7).

- a To fasten two shipping sections together, four bolts are needed (two on each side of the unit). The bolts are run from one base rail into the other and fastened with a nut. Complete each section bottom and top before attaching additional sections.
- b If desired, shipping sections for non curb-ready units can be fastened together internally. To fasten internally, run field-provided #10 sheet metal screws or drill screws (4" long, maximum) through the interior frame channel of one unit into the splice joint of the neighboring section.
- c Handle units with curb-ready bases and vestibules so the lifting bracket can be removed after the unit is placed on the curbing.

Note: Remove the lifting bracket that projects inward over the curbing. Save the self tapping screws. When the adjacent section is placed in position, use self tapping screw to secure the bases together.

Figure 6: Remove Vestibule Lifting Bracket

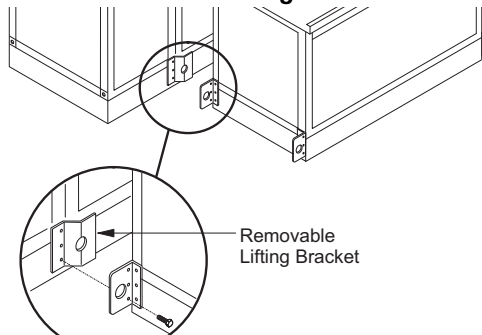
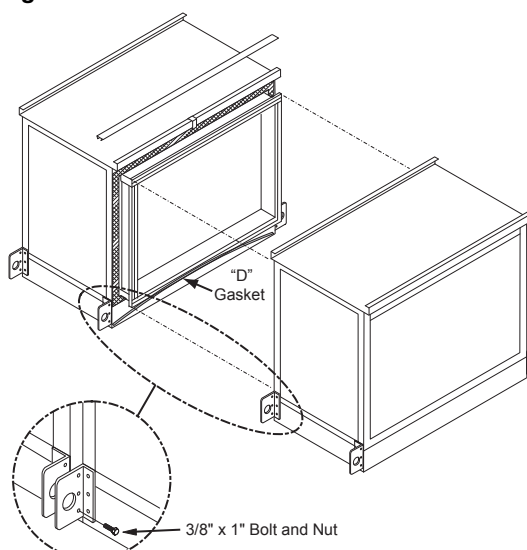

Figure 7: Fasten Bottom of Section



- d A length of “D” gasket is attached to each section (Figure 7). This gasket MUST be installed to the unit base section.

IMPORTANT

The gasket is to be installed in an arc shape with the ends lower than the center, so that any moisture that may reach the gasket will be drained to the outside of the unit.

- e Handle units with curb-ready bases and vestibules so the lifting bracket can be removed after the unit is placed on the curbing.

Note: Remove the lifting bracket that projects inward over the curbing. Save the self tapping screws. When the adjacent section is placed in position, use self tapping screw to secure the bases together.

- f For certain Skyline *Plus* units, use the provided section joining plates to fasten sections together. Space them as shown in Figure 8. Using the provided 1/4"-14 x 1" self tapping screws, drill screw the joining plates into the frame channel on each section, keeping unit sections tight together. Follow instruction drawing included in the assembly kit.

Figure 8: Frame Channel Stiffener Plates (Skyline Plus Units Only)

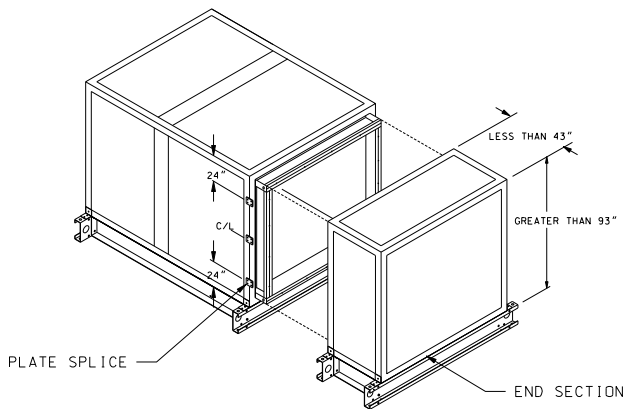

Figure 9: Internal Fastening

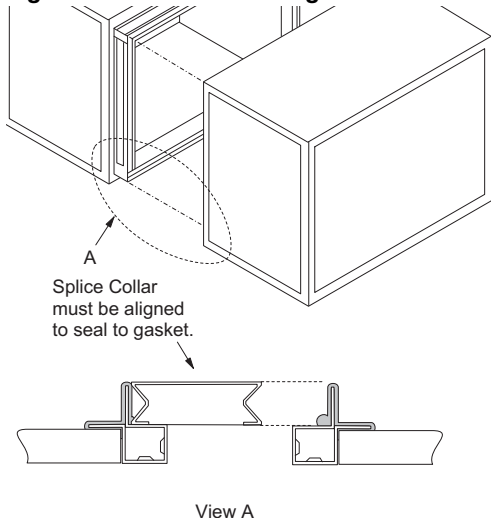
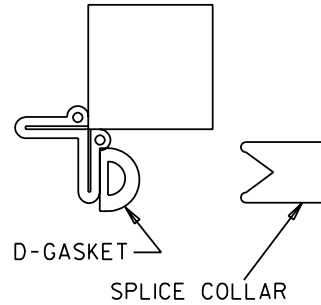
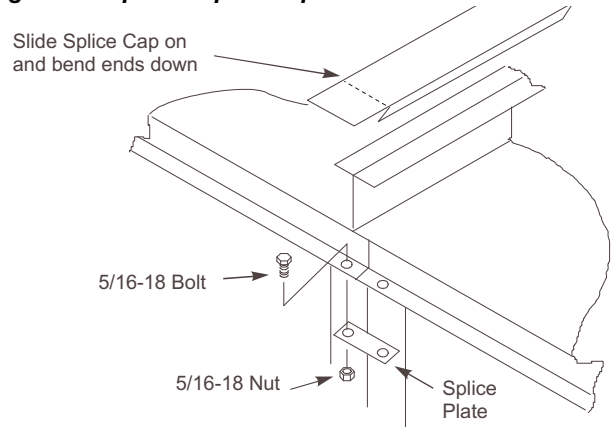

Figure 10: D-Gasket Placement Detail (Skyline Plus Units Only)



- 1 Check that the sealant is compressed between the mating channels when the unit sections are joined. Touch up any places where gaps are noted.
- 2 After sections are seated tightly together, slip the splice cap over the top panel flanges. Bend the ends of the splice cap down to secure in place (Figure 11).
- 3 Assemble the small splice plate at the top rail to secure the sections together at the top. Use 5/16" bolts (Figure 11).

Figure 11: Splice Cap and Splice Plate



Mechanical Installation

Panels, Frame Channels, and Doors

Panel Removal

To remove a side or top panel, remove the flat head Torx 30 fasteners along the sides of the panel. Lift off the panel after removing all fasteners.

Frame Channel Removal

Frame channels that run the length of the unit along the top can be removed to allow access to both the side and top of the unit. To remove the frame channel, first remove the side panel(s). Once the side panel is off, remove the flat head Torx 30 fasteners in the corner of the frame channels. Then pull the frame channel out the side. Remove any panel screws that are within one inch of the of the frame since they are engaged into the gasketed flange of the frame (Figure 12).

Figure 12: Removing Panel Screws

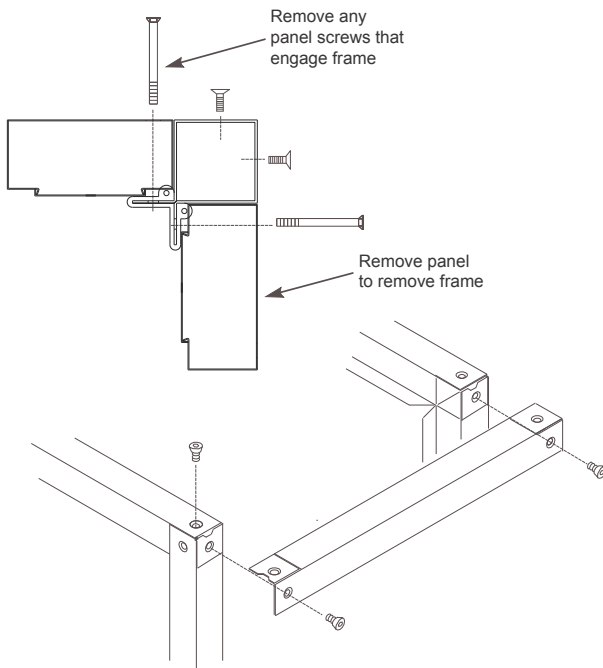

Access Doors and Panels

For routine maintenance, access normally is obtained through access doors or by removing side panels. Removing all flat head fasteners along the sides of a panel allow it to be removed.

Fan and filter sections are always provided with a service door on one side of the unit. If requested on order, doors can be provided on both sides of the unit. Optional service doors are available for most section types and are provided based on customer request.

Fan Section Doors

Note: Opening fan section doors requires using a 1/2" socket wrench (Figure 13), which satisfies ANSI standards and other codes that require the "use of tools" to access compartments containing moving parts or electrical wiring.

CAUTION

Sharp edges and coil surfaces are a potential injury hazard. Avoid contact with them.

ATTENTION

Les bords tranchants et les surfaces des bobines sont un risque de blessure. Ne les touchez pas.

- 1 Insert 1/2" socket and rotate 1/4 turn clockwise as shown in Figure 13. If the handle is on the left side of the door, rotate 1/4 turn counterclockwise.
- 2 Rotate the door handle 1/4 turn clockwise and then 1/4 turn counterclockwise to release any internal pressure or vacuum and open the door. If the handle is on the left side of the door, rotate the door handle 1/4 turn counterclockwise and then 1/4 turn clockwise.
- 3 To prevent air leakage, tighten the door panels by adjusting the jam nuts.

Figure 13: Opening Fan Section Door

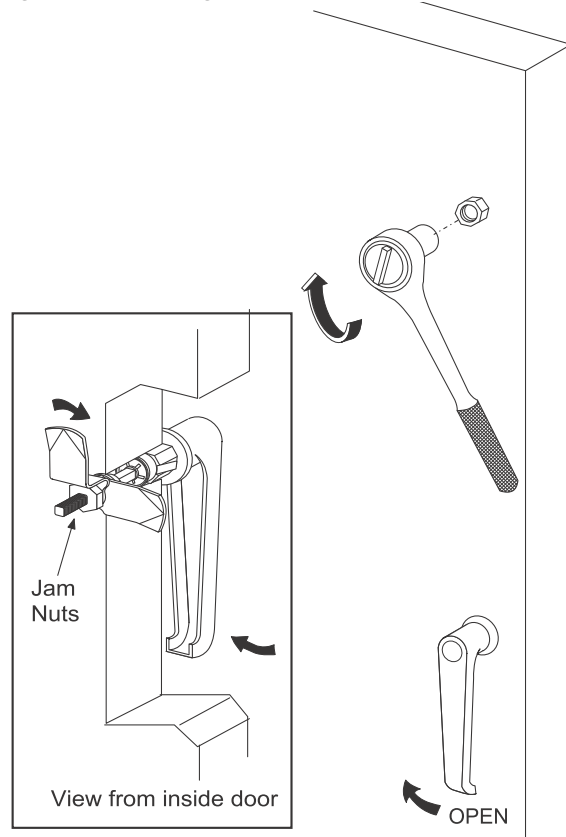

Injected-Foam Insulated Panels

Skyline air handlers now are furnished with double-wall, injected-foam insulated panels. Foam panels are stronger, more rigid, and lighter than panels with fiberglass insulation. The insulation R-value is improved to 13. However, foam insulation can burn when exposed to flame or other ignition sources and release toxic fumes. Take care in cutting and sealing all field-cut openings in these panels.

Panel Cutting Procedure

- 1 Determine the number and location of holes required for electrical conduit, piping, and control wiring as follows:
 - a Check that adequate space is available inside the unit for conduit or pipe routing.
 - b Do not locate holes in a panel that provides access to key maintenance components such as filters and fan assemblies.
 - c Do not locate where the conduit or piping blocks airflow or obstructs hinged access doors.
- 2 Once a proper location is determined, drill a small pilot hole completely through the panel. Then use a sharp hole saw or a saber saw and cut from each side of the panel.
- 3 Seal the double-wall panel on each side with an industrial/commercial grade silicone sealant or duct seal compound. It is extremely important to seal each panel hole or penetration securely so it is airtight, watertight, and so that there is **no exposed insulation**.

⚠ WARNING	
	<p>Flame and smoke can cause equipment damage, severe personal injury, or death. Before operating unit, seal all piping and wiring holes on both inner and outer panels with an industrial grade silicone sealant or duct seal compound. Do not use a cutting torch or expose panel to fire. Panel damage can occur.</p>

⚠ WARNING	
	<p>La fumée et les flammes peuvent endommager le matériel et causer des blessures graves ou la mort. Avant d'utiliser le dispositif, obturer tous les trous de passage de tubulures et de fils ménagés dans les panneaux intérieurs et extérieurs au moyen d'une pâte à base de silicone ou d'un mastic d'étanchéité à conduits de qualité industrielle. Ne pas se servir d'un chalumeau coupeur ni exposer les panneaux à une flamme nue pour ne pas risquer de les endommager.</p>

Figure 14: Cutting/Sealing Injected-Foam Insulated Panels

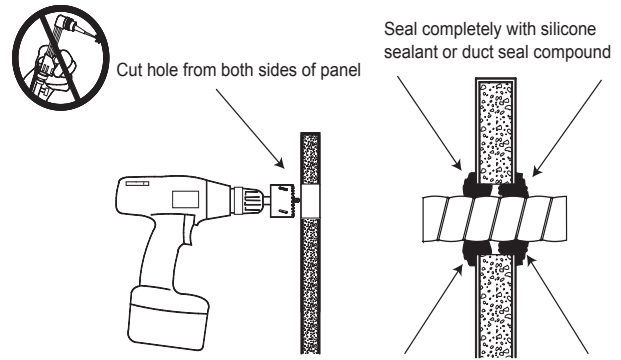

Prop 65—Substances in fuel or from fuel combustion can cause personal injury or death, and are known to the State of California to cause cancer, birth defects or other reproductive harm.

Field Mounting Junction Boxes and Other Components

For field mounting 4" × 4" or smaller junction boxes to the standard panel exterior, use a minimum quantity of four, 3/16" diameter pop rivets. **Do not use self-tapping drill screws. They will not tighten nor secure properly and panel damage can occur.**

If larger, heavier components require mounting on unit panels, use through-bolts with flat washers through both outer and inner panels. To maintain panel integrity, seal both ends with an industrial/commercial grade silicone sealant or duct seal compound.

The unit frame channel is another excellent location for securing heavier components; self-tapping screws are not acceptable. Ensure that the location permits the full operation of all access doors and panels and does not interfere with other vital components.

Duct Connections

Use flexible connectors on the outlet and inlet duct connections of all units. Do not position down flow fans over air ducts that are routed down into the building. Use a discharge plenum when bottom connections are necessary (Figure 15).

Figure 15: Discharge Plenum

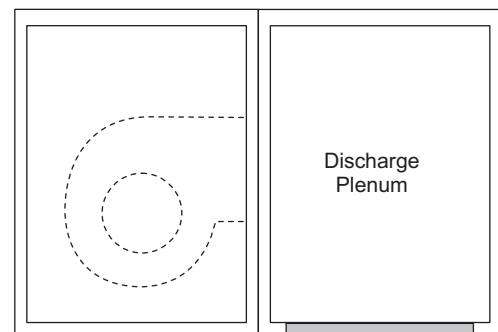

Mechanical Installation

If the unit has a top mixing box or economizer damper or a top duct connection, field fabricate and install flashing to divert moisture from the connection. The flashing must lap over the standing seams of the top panels. The flashing also must lap over the side edges of the unit (Figure 16).

Figure 16: Flashing Over Top Panels and Sides of Units

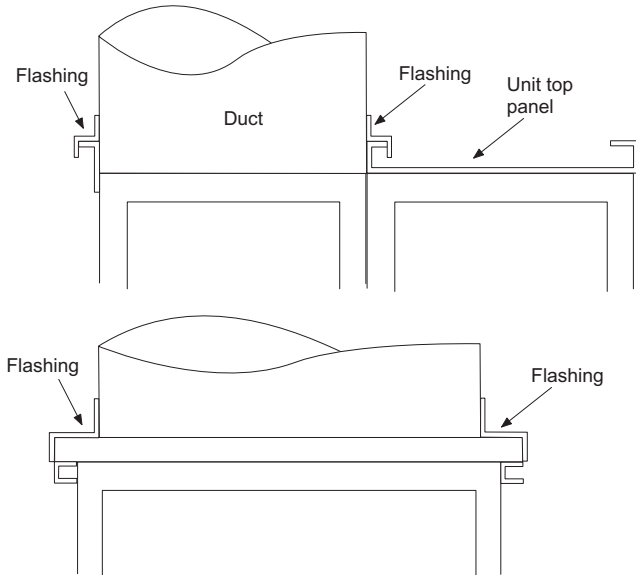

Dampers and Hoods

Side dampers may be provided in the mixing box and economizer sections of units. When dampers are provided, a removable panel is located above the weather hood to provide access to the damper drive shaft. Other access may be available depending on the specific construction of the unit (Figure 17).

Figure 17: Filler Panel Over the Weather Hood

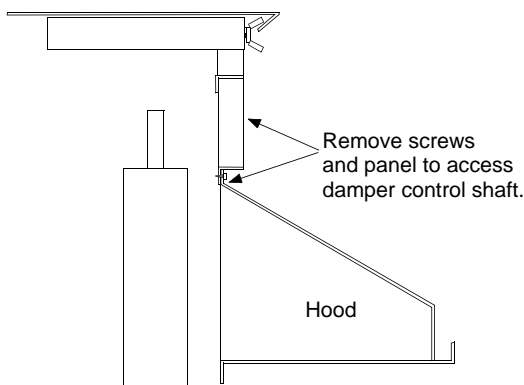

When units are ordered with exhaust hoods and intake hoods adjacent to each other, install a field-supplied barrier to prevent recirculation of exhaust air into the intake openings. (Figure 18).

Figure 18: Field-Installed Barrier Between Hoods

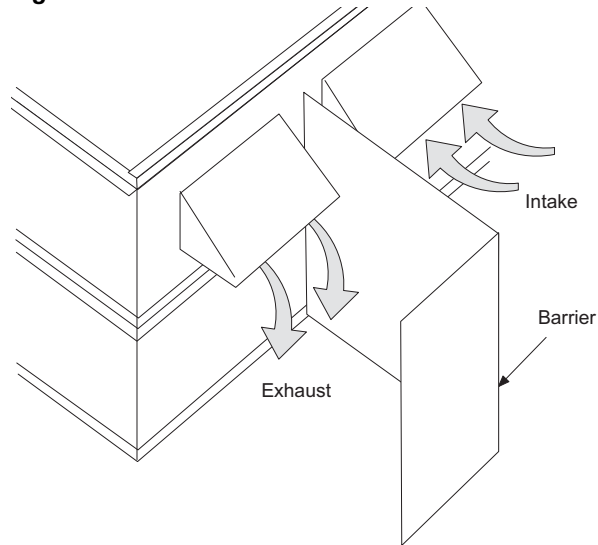

Mounting Actuators

The installing contractor is responsible for the mounting of all field-installed actuators. No provisions are made for the location of these actuators due to the number of options and arrangements available and the variety of specific applications. Typically, actuators are mounted inside the cabinet. Provide proper support for the actuator to avoid excessive stress in the cabinet, linkage, or damper shafts.

Note: Damper blades are at full flow when open to 70 degrees. Do not open blades further than 70 degrees.

Fresh air and return air dampers can be linked together and driven from the same actuator if the dampers are the same size. If the dampers are different sizes, they must be driven by separate actuators and controlled appropriately. Exhaust dampers are always driven by a separate actuator.

A typical rotary electric actuator can handle up to 40 sq. ft. of damper. For pneumatic actuators, allow 5 in-lb per square foot of damper area.

CAUTION

Maximum damper rotation is 70°. Maximum shaft torque is 205 inches/pound. Greater rotation or torque can cause equipment damage.

ATTENTION

La rotation maximale des volets est de 70°. Le couple (torque) maximum de l'arbre est de 205po/lb. Une plus grande rotation (ou torque) peut endommager l'équipement.

Face and Bypass Section Mounting

Internal and external face and bypass sections are mounted together using the instructions for horizontal components and do not require additional instruction. Skyline air handlers are provided with a bypass duct that is integral to the unit construction and requires no field assembly.

Face and bypass dampers may or may not be linked together. When dampers are placed before a single bank of coils, they always are linked together and require a single actuator. When dampers bypass a stacked or staggered coil, the dampers are not linked and require multiple actuators.

Face and bypass dampers have a torque requirement of 10 in-lbs per square foot of damper face area.

Isolation Dampers for Multiple Fans

Optional isolation dampers can be provided on multiple fans to prevent backflow through a fan that is turned off for service. These isolation dampers are not intended to be used to control flow through the fan. The isolation damper for a fan that is going to be started must be positioned in the full open position before the fan is started. Do not start a fan with the damper located at the inlet with the damper fully or partially closed. This can cause airflow, vibration, and sound problems that can lead to failure.

Isolation dampers can be provided with actuators that are mounted in the airstream. Actuator sizing for the isolation dampers should be based on 9 in-lb per square foot of damper.

Piping Vestibules

For units that include a piping vestibule, cut the openings for routing the field piping as required in the field. Carefully seal passages cut through the panels to prevent air leakage. A single metal thickness pan is provided in the bottom of the curb-mounted vestibule. The pan can be removed if necessary. If holes are cut into the pan for a piping passage, seal the holes to prevent moisture leakage (Figure 19).

Figure 19: Seal Holes for Piping—Curb Mounted Units

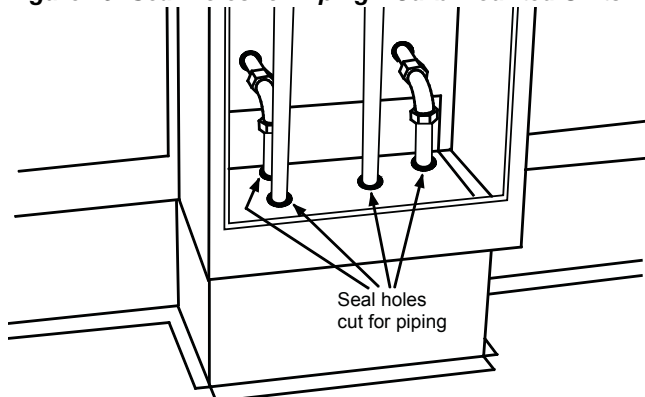

For units with standard base rails, the vestibule is open to the coil section; therefore, seal all holes to prevent air leakage.

Figure 20: Seal Holes for Piping—Standard Base Rail Units

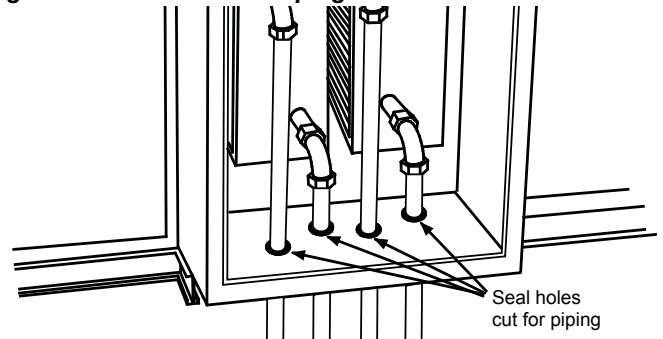

Piping and Coils

When designing and installing piping:

- Follow applicable piping design, sizing, and installation information in ASHRAE handbooks.
- Observe all local codes and industry standards.
- Do not apply undue stress at the connection to coil headers; **always use a backup pipe wrench.**
- Support pipework independently of the coils.

Water Cooling Coils

Note: Use glycol in water coils for outdoor air handlers. Power failures and other mechanical issues can expose coils to freezing temperatures.

- Water supply, water return, drain, and vent connections extend through the end panel of the coil section. All connections are labeled on the end panel.
- Water supply and water return connections are typically male NPT iron pipe.
- When installing couplings, do not apply undue stress to the connection extending through unit panel. **Use a backup pipe wrench to avoid breaking the weld between coil connection and header.**
- Follow recommendations of the control manufacturer regarding types, sizing, and installation of controls.

Mechanical Installation

Direct Expansion Coils

- The coil distributor and suction connection extend through the end panel of the coil section.
- Check nozzle in distributor for proper tonnage.
- When a (field supplied) thermostatic expansion valve is located outside the unit and connected directly to the distributor (except on units with piping vestibules). Do not apply heat to the body of the expansion valve.
- The thermostatic expansion valve must be the external equalizer tube type. Connect the 1/4-inch diameter external equalizer tube provided on the coil to the connection on the expansion valve.
- Use care when piping the system, making sure all joints are tight and all lines are dry and free of foreign material. For typical refrigerant piping, see condensing unit product manual.

Steam Coils

Piping (see Figure 21)

- Steam supply and steam return connections typically are male NPT iron pipe and are labeled on the end panel of coil section. Connections extend through the coil section end panel.
- When installing couplings, do not apply undue stress to the connection extending through unit panel. **Use a backup pipe wrench to avoid breaking the weld between coil connection and header.**
- Support piping independently of coils and provide adequate piping flexibility. Stresses resulting from expansion of closely coupled piping can cause serious damage.
- Do not reduce pipe size at the coil return connection. Carry return connection size through the dirt pocket, making the reduction at the branch leading to the trap.

Coils

- Pitch all steam coils in units toward the return connection.
- Do not drip supply mains through the coil.
- Do not attempt to lift condensate when using modulating or on/off control.
- Install vacuum breakers on all applications to prevent retaining condensate in the coil. Generally, connect the vacuum breaker between the coil inlet and the return main. The vacuum breaker should be open to the atmosphere and the trap design should allow venting of large quantities of air.

Traps

Note: Do not place steam traps outdoors.

- Size traps in accordance with the manufacturers' recommendations. Make sure the required pressure differential is always available. **Do not undersize.**
- Use float and thermostatic or bucket traps for low pressure steam. On high pressure steam, use bucket traps. Use thermostatic traps only for air venting.
- Use bucket traps for on/off control only.
- Locate traps at least 12 inches below the coil return connection.
- Multiple coil installation—individually trap each coil or group of coils.
- Coils in series—use separate traps for each coil, or a bank of coils.
- Coils in parallel—a single trap can be used, but an individual trap for each coil is preferred.
- Do not attempt to lift condensate when using modulating or on/off control.
- With coils arranged for series airflow, use a separate control on each bank or coil in the direction of airflow.

Valves

- Do not use modulating steam valves on high pressure systems.
- Properly size modulating valves. **Do not undersize.**
- Avoid freezing conditions (entering air temperatures below 35°F).
- McQuay strongly recommends 5JA, 8JA, 5RA and 8RA coils.
- Supply 5 psi steam to coils at all times.
- Do not use modulating valves. Provide control by face and bypass dampers.
- Consider using two or three coils in series with two position steam control valves on the coil or coils that handle 35°F or colder air. Use a modulating valve on the downstream coil to provide the desired degree of control.
- Thoroughly mix fresh air and return air before it enters the coil. Also, to obtain true air mixture temperatures, properly locate temperature control elements.
- As additional protection against freeze-up, install the trap sufficiently below the coil to provide an adequate hydrostatic head to remove condensate during an interruption in the steam pressure. Estimate three feet for each 1 psi of trap differential required.
- On startup, admit steam to coil ten minutes before admitting outdoor air.
- Close fresh air dampers if steam supply pressure falls below the minimum specified.

Figure 21: Piping Arrangements

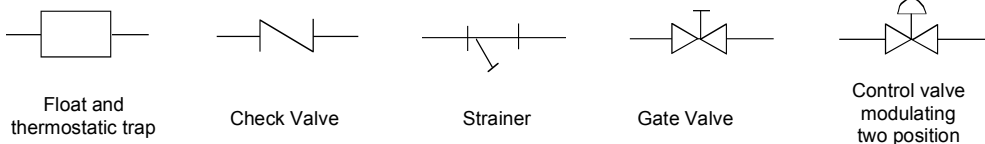

High Pressure (over 25 psi)

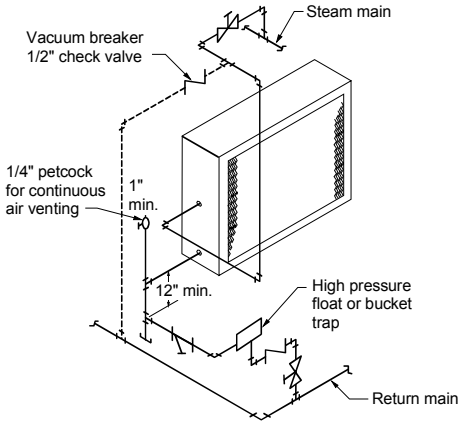

5GA or 8GA coils. Note that the addition of a vacuum breaker to permit the coil to drain during shutdown.

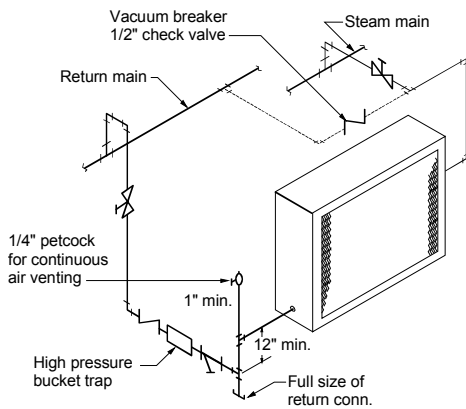

5TA, 8TA, or 5HA coils. Condensate is lifted to overhead return main.

Low Pressure (to 25 psi)

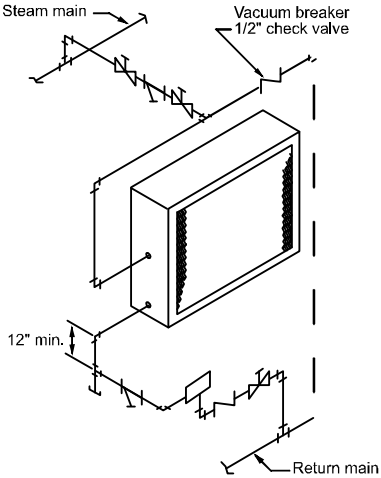

5J, 5G, 8J or 8G coils.

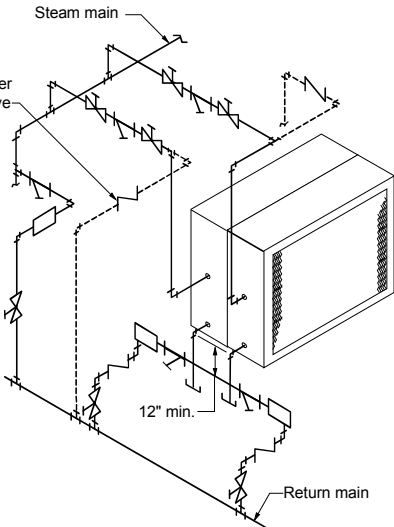

5JA or 8JA coil. Installed in series. Note that each coil must have a separate control valve and trap.

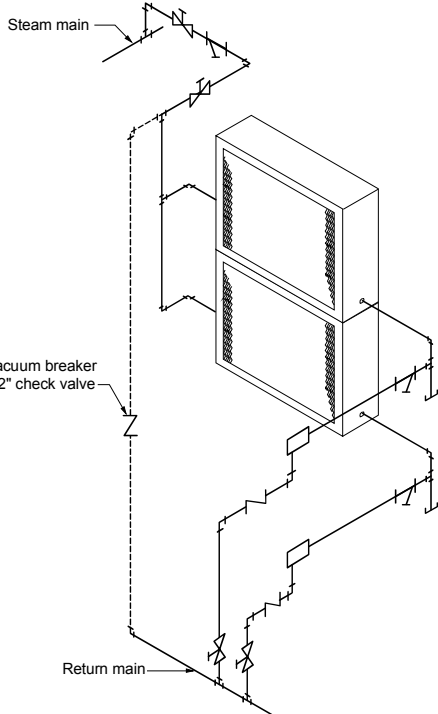

5RA, 8RA, or 5SA coils. Banked two high, individual trapping of each coil as shown is preferred.

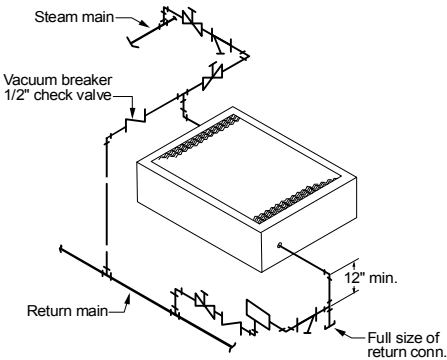

5RA, 8RA, or 5SA coils. Installed

Mechanical Installation

Water Heating Coils

CAUTION

Improper installation, use, or maintenance of water heating coils can cause equipment damage. Read and follow instructions carefully.

ATTENTION

Si l'installation, l'utilisation ou l'entretien des serpentins de chauffage à eau sont inadéquats, ceci endommagera l'équipement. Lire et suivre attentivement les instructions.

- Water supply and water return connections extend through the end panel of the coil section. All connections are labeled on the end panel.
- Water supply and water return connections are male NPT iron pipe.
- When installing couplings, do not apply undue stress to the connection extending through unit panel. Use a backup pipe wrench to avoid breaking the weld between the coil connection and header.
- Follow recommendations of the control manufacturer regarding types, sizes, and installation of controls.
- Do not use hot water coils with entering air below 40°F.
- If fresh air and return air are to be heated by a hot water coil, carefully design the system to provide thorough mixing before air enters the coil.
- To prepare coils for winter operation, see [Winterizing Water Coils](#), page 32.

Drain Pan Traps

Run drain lines and traps full size from the drain pan connection. Install drain pan trap to allow condensate to drain freely. On both blow-through and draw-through units, the trap depth and the distance between the trap outlet and the drain pan outlet must be twice the static pressure in the drain pan section under normal operation so the trap remains sealed ([Figure 22](#)).

Figure 22: Allow Adequate Distance Between Trap Outlet and Drain Pan Outlet

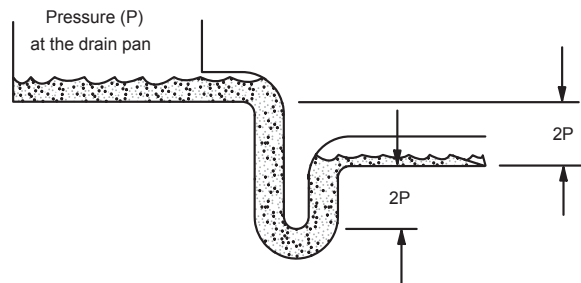

Note: The door panels on some applications have a close clearance over the drain pipes. Extend the drain fitting with a coupling if necessary for door clearance ([Figure 23](#)).

Note: Use material that can withstand freezing temperatures for outdoor drain traps.

Note: Drain traps that dry out can allow cold air to seep into the equipment.

Figure 23: Extend Drain Fitting for Door Clearance

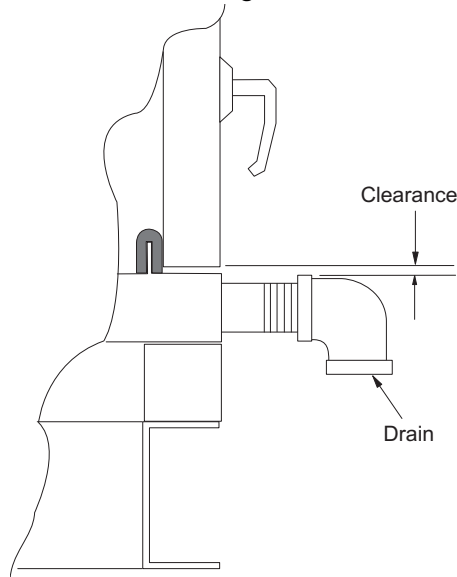

Internal Isolation Assembly Adjustment

On units with internally isolated fan and motor assemblies, the assemblies are secured for shipment. with a tie-down at each point of isolation.

Before Operating the Unit:

Remove the shipping brackets and tie-down bolts (see [Figure 25](#), [Figure 26](#) and [Figure 27](#)) and discard. The shipping brackets located on the opposite drive side of the unit are difficult to access from the drive side of the unit. Either remove them before the unit is assembled or remove the panel on the opposite drive side to gain access.

The spring isolators under the four corners of the fan and motor assembly are factory adjusted while the fan was not running. See [Table 1](#) through [Table 5](#) below. With the unit operating at normal cfm and static pressure, all the isolators should be at the same height opening. If adjustments are required, loosen the 1/2" cap screw on top of the isolator and turn the adjusting bolt to lower or raise the fan and motor base. Retighten the cap screw when adjustments are completed.

Table 1: Motor Beside Fan Spring Mount Adjustments

Spring mount adjustment at rest			
Isolator position	Top or bottom horz. H	Downblast H	Upblast H
Unit sizes 003 – 035			
1	3.75	3.75	4.25
2	4.25	3.75	4.25
3	4.25	3.75	4.25
4	3.75	3.75	4.25
Unit sizes 040 – 090			
1	6.00	6.75	6.75
2	6.50	6.75	6.75
3	6.50	6.75	6.75
4	6.00	6.75	6.75

Table 2: Motor Behind Fan Spring Mount Adjustments

Spring mount adjustment at rest			
Isolator position	Top or bottom horz. H	Downblast H	Upblast H
Unit sizes 003 – 035			
1	6.75	6.75	6.75
2	6.75	6.75	6.75
3	6.75	6.75	6.75
4	6.75	6.75	6.75
Unit sizes 040 – 090			
1	6.75	6.75	6.75
2	6.75	6.75	6.75
3	6.75	6.75	6.75
4	6.75	6.75	6.75

For models 040 through 090 with housed fans, the isolators should be at equal height during fan operation (6"). Center the fan outlet in the outlet panel opening. If adjustment is required, loosen the cap screw on top of the isolator assembly. Turn the adjustment nut below the fan frame to lower or raise the fan motor and frame assembly. Retighten the cap screw on top of the isolator assembly.

Figure 24: Adjusting Large Spring Mount Assembly

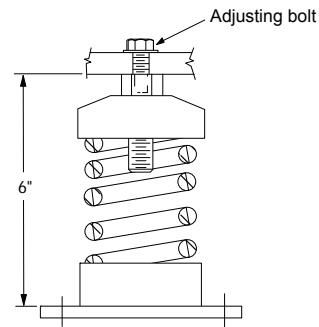

Table 3: Class II Belt-Drive Plenum Fan Spring Height

Fan Size	Isolator Type	Operating Height (in.)
13–16	Standard 2" Deflection	4.5
18–36	Standard 2" Deflection	4.0
13–36	Seismic	4.0
40–60	All	6.75

Table 4: Class III Plenum Fan Spring Height

Cabinet Width	Isolator Type	Operating Height (in.)
Width < 108"	All	4.0
Width > or = 108"	All	6.75

Table 5: Class II Direct-Drive Plenum Fan Spring Height

Fan Size	Isolator Type	Operating Height (in.)
11–36	All	4.0
40–44	All	6.75

Mechanical Installation

Figure 25: Removing "Motor Behind" Shipping Brackets

Unit sizes 006 - 090

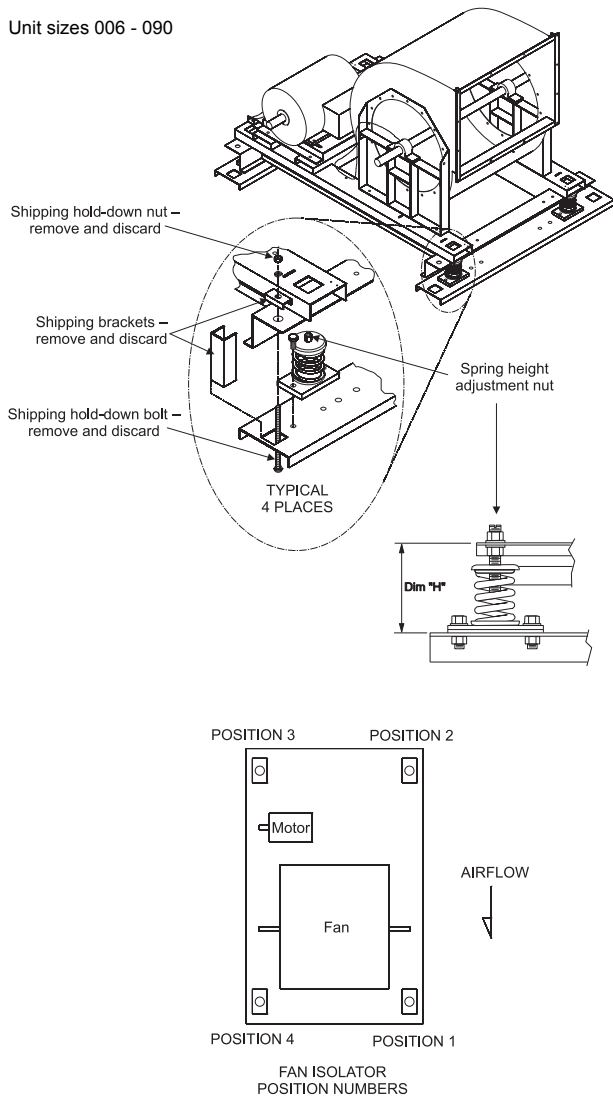

Figure 26: Removing "Motor Beside" Shipping Brackets

Unit sizes 006 - 090

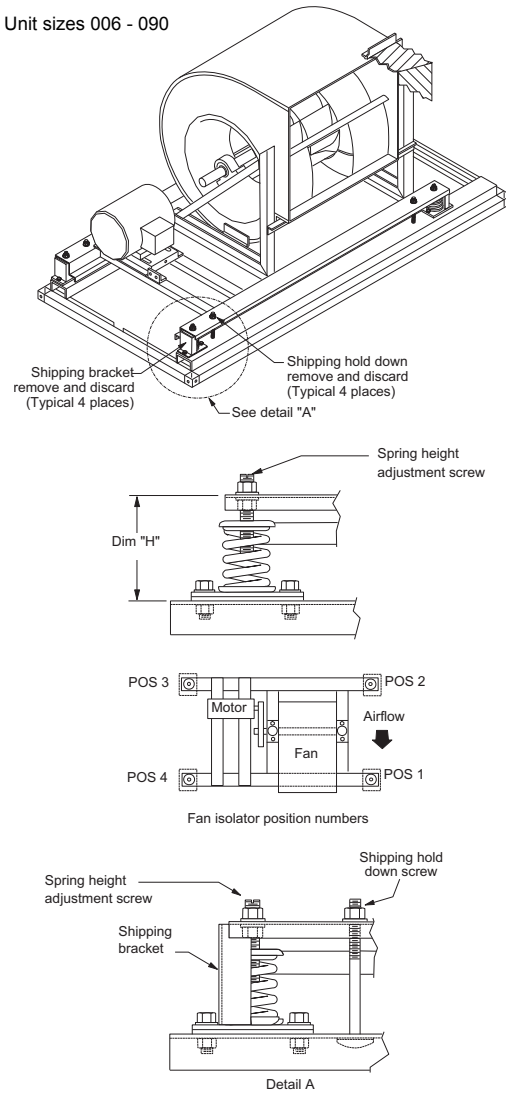
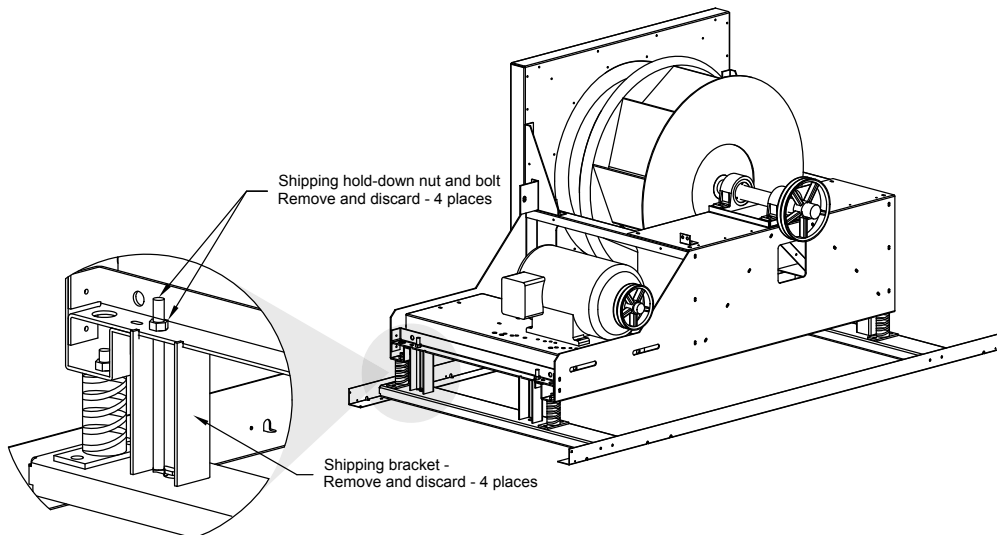

Figure 27: Plenum Fan Typical Shipping Brackets



Wiring

DANGER

Capacitor hazardous voltage! Failure to disconnect power and discharge capacitors before servicing will result in serious injury or death.

Disconnect all electric power (including remote disconnects) before servicing. Perform lockout/tagout procedures to ensure that power can not be energized. For variable frequency drives, or other energy storing components that have been furnished and mounted by either McQuay, or by others, refer to the specific manufacturer's literature for allowable waiting periods for discharge of capacitors. Verify capacitors have been discharged using an appropriate voltmeter.

ADVERTISSEMENT

Voltage de condensateur à risque de danger! À défaut de débrancher la puissance électrique et de décharger le condensateur avant de faire le service, il peut en résulter des blessures sérieuses et même la mort.

Débranchez toute puissance électrique (incluant les sectionneurs à distance) avant de faire du service. Assurez-vous de procéder au cadenassage et à la pose d'avis assurant que la puissance ne peut être rétablie.

Pour le variateur de fréquence variable ou tout autre composante pouvant accumuler de l'énergie qui auraient été fournis et installés par McQuay ou autres, se référer à la littérature spécifique du manufacturier donnant les périodes spécifiques d'attente nécessaires pour la décharge du condensateur. Vérifier que le condensateur est totalement déchargé avec les voltmètres appropriés.

CAUTION

Use copper conductors only. Failure to use copper conductors can result in equipment damage.

ATTENTION

Utiliser du fil de cuivre seulement. La non utilisation de fil de cuivre peut causer des dommages à l'équipement.

- Electrical service to each fan must correspond to the rated voltage on the motor or electrical panel nameplate and conform to the National Electric Code and local restrictions.
- Connect each fan section metal frame to the building electrical ground.
- A door electrical interlock is not provided as standard.
- Thermal motor protection is external to the unit.

Locate electrical conduit entrances for units above the bottom of the unit, high enough to clear components inside, but below the bottom of the fan motor junction box (Figure 28).

Figure 28: Electrical Conduit Location

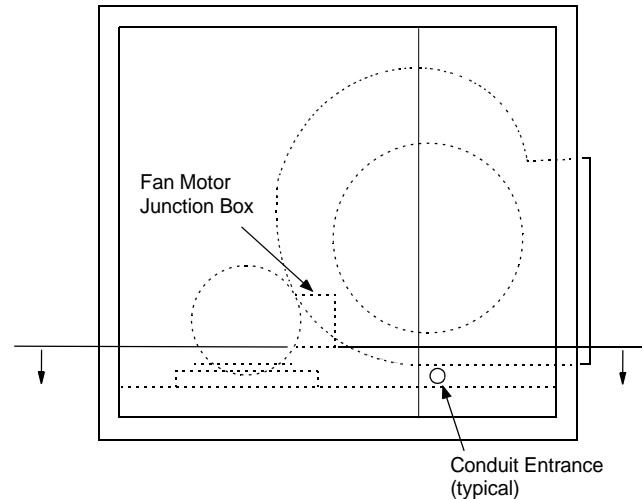

CAUTION

The base section of each cabinet has a drip pan installed below every panel that drains to the outside frame trough. Any holes cut through the bottom of the unit must also penetrate the drip pan. If holes are cut in the drip pan, seal them to prevent moisture leakage.

ATTENTION

Chaque cabinet est muni d'une base avec une panne d'égouttement installée en-dessous de chaque panneau qui évacuera l'eau vers la gouttière extérieure. Tous les trous percés au bas de l'unité doivent pénétrer la panne d'égouttement. S'il y a des trous dans la panne d'égouttement, les sceller pour empêcher les fuites d'eau.

- When the unit is provided with an external junction box and variable frequency drive (VFD), the VFD itself will be mounted on the drive side fan panel inside the fan cabinet. The external junction box will provide loose wire connection to the VFD and to the motor. An external mounted keypad/display control box will be provided and connected to the VFD for manual adjustment of the VFD.
- When not being serviced, close and secure electrical panel doors to prevent accidental contact with live parts and prevent ingress of moisture and airborne contaminants.
- For instances where multiple motors are being driven by a single VFD, be sure to set up the VFD and size the wiring according to the power requirements of all motors that are being driven by that VFD.

Electrical Installation

- Control wiring—access to the VFD is through the fan cabinet access door for single fans. Provide shielded cable only as described in the VFD manual provided with the unit. Route wire through panel so that it not interfere with any other components or in the way of any access doors. Do not drill through drip or drain pans. Refer to the VFD installation manual provided with the unit for detailed control wiring instructions.
- For multiple fans in parallel, the VFD(s) are mounted inside of the electrical enclosure, which is mounted on the exterior of the fan section. When multiple fan sections are provided with multiple VFDs, they must be set up so that the fans always start simultaneously and are set to ramp up and down together. Do not attempt to run fans in parallel at different speeds as this can result in uneven airflow that can cause performance, sound, and vibration problems that can lead to failure. Provided that the fan is capable of running fast enough and the motor is sized appropriately, VFDs may be operated up to a maximum recommended frequency of 90 Hertz for 1800 RPM and slower motors. Motors that are 3600 RPM may be operated up to a maximum speed of 4000 RPM or 66.7 Hertz provided the fan is rated that high. Operation above 4000 RPM can damage motor bearings and is not recommended.

Startup Checks

When performing startup and service, always take thorough safety precautions. Only trained, experienced personnel should perform these functions.

WARNING

Rotating fan. Can cause severe injury or death. Before servicing fans, lockout and tag out power.

AVERTISSEMENT

Ventilateur en rotation. Peut causer des blessures sévères ou même la mort. Avant d'effectuer l'entretien des ventilateurs, bloquer et couper la tension.

WARNING

Fire/electric shock hazard. Can cause property damage, personal injury or death. Wire fan power supply and ground motor frame in accordance with local electric codes.

AVERTISSEMENT

Risques d'incendie et d'électrocution pouvant causer des dommages matériels, des blessures et même la mort. L'alimentation électrique du moteur du ventilateur de même que la mise à la terre du châssis du moteur doivent être faits conformément aux codes d'installations électriques en vigueur.

WARNING

Fan motor requires overload protection. Failure to provide motor overload protection can result in fire, property damage, electric shock, personal injury, or death. Connect motor to an overload protective device rated in compliance with local electric codes.

AVERTISSEMENT

Risques d'incendie et d'électrocution pouvant causer des dommages matériels, des blessures et même la mort. Connecter au moteur du ventilateur électrique un dispositif de protection contre les surcharges conforme aux codes d'installations électriques en vigueur.

CAUTION

Do not overheat fan motor. High air temperatures in the fan section can cause the fan motor to burnout. On draw-through air handlers or air handlers with the fan section down the air stream from the heating section, the discharge air temperature of the heating section must not exceed 104°F (40°C).

ATTENTION

Risques de dommages dans le moteur du ventilateur électrique. Si la température de l'air à proximité du ventilateur est élevée, le moteur du ventilateur électrique peut chauffer et brûler. Sur les transmetteurs d'air à circulation transversale ou les transmetteurs dont le ventilateur est en aval de l'unité de chauffage, régler la température de l'air sortant de l'unité de chauffage à 40°C (104°F).

Before Starting the Unit:

Before entering fan section, make sure that fan electrical power source is disconnected and locked in the OFF position.

- 1 Check that the unit is completely and properly installed with ductwork connected.
- 2 Check that construction debris is removed/filters are clean.
- 3 Check that all electrical work is complete and properly terminated.
- 4 Check that all electrical connections are tight and that the proper voltage is connected. Phase imbalance must not exceed 2%.
- 5 Check that ball bearings on the fan shaft and motor are prelubricated and do not need grease before startup.
- 6 Check tightness of setscrews in bearings and fan wheel(s). If retightening is needed, position the fan wheel(s) per [Table 6](#) through [Table 9](#) and [Table 11](#) through [Table 13](#), [page 22](#). Torque set screws per [Table 10](#) and [Table 14](#), [page 22](#).

CAUTION

Equipment damage due to loose fasteners represents improper start-up and equipment abuse. It is not covered by the warranty.

AVERTISSEMENT

Les dommages dus à des attaches installées de façon inappropriée représentent un démarrage inadéquat et un abus d'équipement. Ceci n'est pas couvert par la garantie.

- 7 Check alignment of fan and motor sheaves and belt tension. Adjust if necessary. Check tightness of sheave setscrews and/or capscrews. See [Table 10](#), [page 22](#).
- 8 Leak test the thermal system to verify that connections are tight.
- 9 Check that the condensate drain is trapped.
- 10 Rotate the shaft by hand to be sure it is free.
- 11 If multiple fans are supplied with a block off plate and it is installed on one of the fans, make sure to only start the fans without the block off plate. Do not start any fan that has the block off plate installed on it.

Operation Guidelines

- If multiple fans are supplied with isolation dampers, make sure the isolation dampers are fully open before starting the fans.

VFD Setup

Fans ordered with VFDs that were factory installed are setup and tested prior to shipment. Prior to starting the fan(s), double check the VFD settings according to the recommendations in the VFD manual.

Once the correct VFD settings are verified, the fans should be run through a sweep of the full range of operating speeds that are expected to check for any vibration issues. If any areas of concern are located, it is recommended to lock out those frequencies using the VFD (see lock out frequencies or skip frequencies in the VFD manual). This will ensure that the fans will never operate continuously at those points, but will rather pass through them to get to the desired points of operation.

Fan Startup

Start and run fan. See [Figure 33](#) for proper fan rotation. Observe the rotation. If the fan operates backward, reverse two legs of the three-phase motor connections.

Note: Variable pitch fan drives usually are provided for operation in the mid-speed adjustment range. However, the drives usually ship with the adjustment opened up for minimum fan speed. Adjust the drives for the proper airflow. See [Fan Drive](#), page 26.

After the First 48 Hours of Operation:

- Disconnect and lock electrical power source.
- Check tightness of all bearing, wheel, and sheave setscrews (or capscrews). See [Table 10](#), page 22.
- Recheck belt tension and adjust if necessary. Belts that are tensioned sufficiently to slip one to two seconds at startup perform satisfactorily, extending life and reducing vibration. If retensioning is necessary, be certain to retain sheave alignment.

Fan Wheel Alignment

Figure 29: Wheel-to-Inlet Tunnel Relationship—Airfoil Type Fan Wheels (Housed)

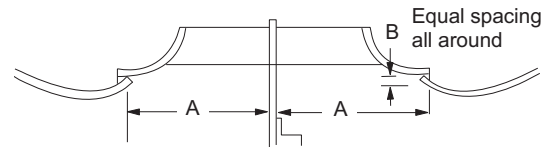

Table 6: Wheel-to-Inlet Funnel Relationship—Airfoil Type

Airfoil									
Unit sizes 003 to 035					Unit sizes 040 to 090				
Dia.	A (in)	A (mm)	B (in)	B (mm)	Dia.	A (in)	A (mm)	A (in)	B (mm)
13.22	4.56	116	0.21	5.33	20.00	7.19	183	0.31	7.87
14.56	5.06	129	0.21	5.33	22.25	7.69	195	0.33	8.38
16.18	5.62	143	0.21	5.33	24.50	8.56	217	0.31	7.87
17.69	6.90	175	0.22	5.59	27.00	9.47	241	0.63	16.00
21.56	7.59	193	0.24	6.10	30.00	10.47	266	0.39	9.91
24.00	8.45	215	0.23	5.84	33.00	11.75	298	0.38	9.65
					36.50	12.78	325	0.38	9.65
					40.25	14.31	363	0.50	12.70

- Note:
- To obtain rated air performance, dimensional relationship must be held.
 - To obtain dimension A, loosen setscrews in wheel hub(s), shifting wheel(s) axially as needed, and retightening setscrews.
 - To obtain dimension B, loosen screw and washer fasteners around periphery of funnel(s), shifting funnel radially as required, and re-torquing fasteners.

Figure 30: Wheel-to-Inlet Funnel Relationship—Forward Curved Type Fan Wheels

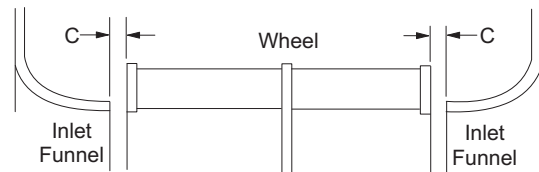

Table 7: Wheel-to-Inlet Funnel Relationship—Forward Curved Type Fan Wheels

Forward curved					
Unit sizes 003 to 035			Unit sizes 040 to 090		
Diameter (in)	C (in)	C (mm)	Diameter (in)	C (in)	C (mm)
9 x 4	0.25	6.35	20 (Class 1 & 2)	0.24	6.10
9 x 7	0.13	3.30	22.38 (Class 1 & 2)	0.41	10.41
9 x 9	0.25	6.35	25 (Class 1 & 2)	0.47	11.94
10	0.22	5.59	27.62 (Class 1 & 2)	0.47	11.94
12	0.35	8.89	30 (Class 1 & 2)	0.47	11.94
15	0.44	11.18	33 (Class 1 & 2)	0.50	12.70
18	0.25	6.35	36 (Class 1 & 2)	0.75	19.05
20 (Class 1 & 2)	0.73	8.54			
22 1/2 (Class 1 & 2)	0.59	14.99			
24 1/2 (Class 1 & 2)	0.56	14.22			

- Note:
- To obtain rated air performance, dimensional relationship must be held.
 - Adjust dimension C by loosening wheel hub setscrews, shifting wheel(s) axially as needed, and retightening setscrews

Figure 31: Wheel-to-Inlet Funnel Relationship—13 to 36 Belt-Drive Plenum Fans

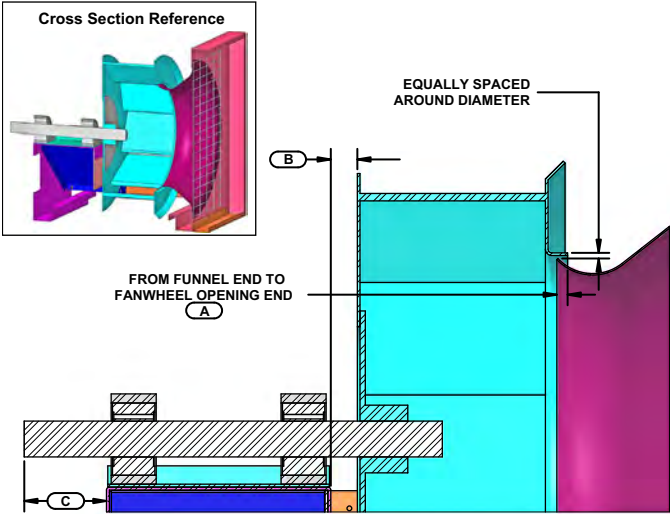

Table 8: Wheel-to-Inlet Funnel Relationship—13 to 36 Belt-Drive Plenum Fan

Wheel-Funnel Parameters			
Size	A	B	C
13	0.25	0.91	3.50
15	0.25	0.91	3.50
16	0.25	0.91	3.50
18	0.38	0.86	3.88
20	0.42	1.11	3.88
22	0.45	1.11	3.88
24	0.51	1.11	3.88
27	0.55	1.36	4.50
30	0.62	1.36	4.50
33	0.55	1.50	5.00
36	0.63	1.50	5.00

Figure 32: Wheel-to-Inlet Funnel Relationship—40 to 60 Belt-Drive Plenum Fans

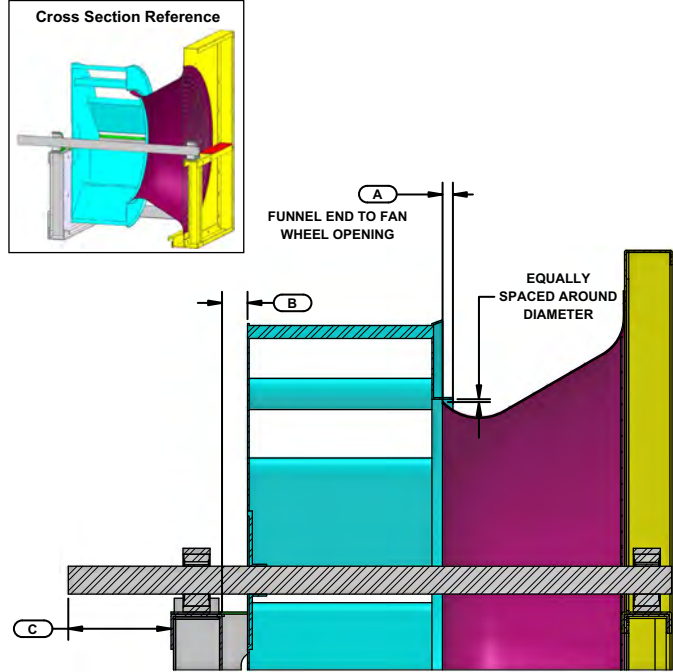
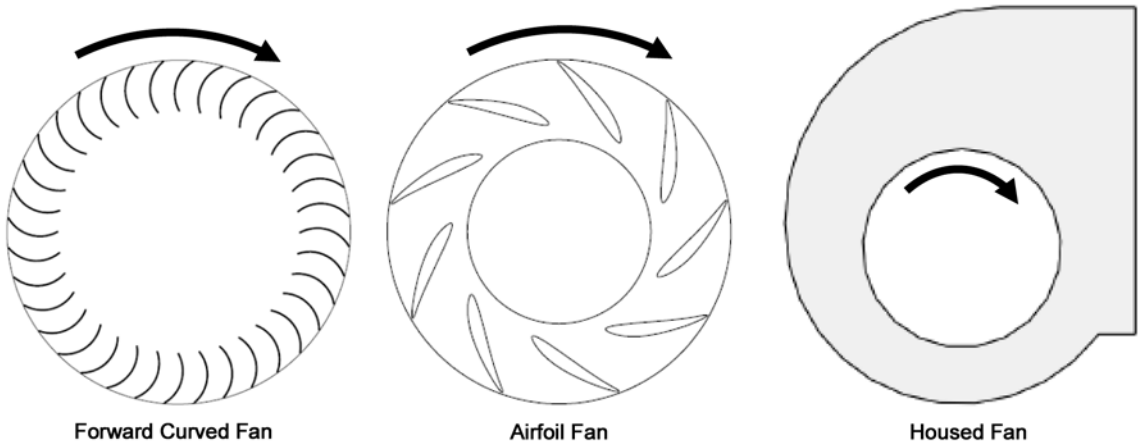

Table 9: Wheel-to-Inlet Funnel Relationship—40 to 60 Belt-Drive Plenum Fan

Wheel-Funnel Parameters			
Size	A	B	C
40	0.82	2.00	4.88
44	0.91	2.25	5.50
49	1.00	2.50	5.50
54	1.10	2.50	5.50
60	1.23	3.00	5.50

Figure 33: Fan Wheel Rotation



Fan wheel should rotate as shown

Operation Guidelines

Setscrews on MPQ fan wheels must be installed using a calibrated torque wrench to the value listed below, $\pm 5\%$. The fasteners must be periodically checked to satisfy agency requirements for components on rotating machinery.

Table 10: Setscrew Torque Specifications—Class II Plenum Fans Only

Fan Size	Setscrew Size	Torque (ft.-lb)	
		Aluminum	Steel
11/12/13	3/8	19.2	N/A
15	3/8	19.2	N/A
16	3/8	19.2	N/A
18	3/8	19.2	N/A
20	3/8	19.2	N/A
22	3/8	19.2	N/A
24	3/8	19.2	N/A
27	3/8	19.2	22
30	1/2	41.7	55
33	1/2	41.7	55
36	1/2	41.7	55
40	1/2	41.7	55
44	1/2	41.7	55
49	1/2	41.7	55
54	1/2	41.7	55
60	3/4	115	150

Figure 34: Wheel-to-Inlet Funnel Relationship—Inline Fans

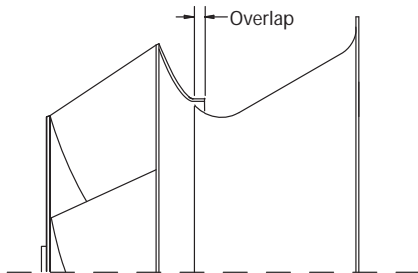

Table 11: Wheel-to-Inlet Funnel Relationship—Inline Fans

Wheel—funnel overlap	
Size	Overlap (in.)
150	0.375
165	0.438
182	0.562
200	0.625
222	0.688
245	0.750
270	0.812
300	0.875
330	1.000
365	1.125
402	1.250
445	1.375

Table 12: Wheel to Inlet Funnel Relationship - Direct Drive Class II fans

Fan Size	Overlap (in.)
11	0.25
12	0.25
15	0.25
16	0.38
18	0.38
20	0.41
22	0.45
24	0.50
27	0.55
30	0.61
33	0.67
36	0.75
40	0.82
44	0.91

Table 13: Wheel to Inlet Funnel Relationship - Direct Drive Class III fans

Fan Size	Overlap (in.)
13	0.12
15	0.19
16	0.25
18	0.31
20	0.38
22	0.44
24	0.50
27	0.56
30	0.62
33	0.75
36	0.81
40	0.88
44	0.94
49	1.0
54	1.06
60	1.12

Table 14: Bearing Collar and Wheel Hub Set Screw Torque (All Fans Except Class II Plenum Fans)

Set screw Diameter (in)	Minimum torque	
	ft/lbs	kg/m.
1/4	5.5	.76
1/16	10.5	1.45
3/8	19.0	2.63
7/16	29.0	4.01
1/2	42.0	5.81
5/8	92.0	12.72

Operating Limits

Do not exceed the operating limits in [Table 15](#) through [Table 19](#). A fan wheel operated beyond the rpm and temperature limits shown can suffer permanent distortion or fracture. The resulting unbalance can cause severe unit vibration

Table 15: Unit Sizes 003 to 035

Fan operating limits										
Forward curved—housed										
Diameter	9 × 4	9 × 7	9 × 9	10.62	12.62	15	18	20	22.25	24.50
Maximum rpm Class I	N/A	2189	2223	1934	1614	1328	1155	1050	944	858
Maximum rpm Class II	2700	2854	2896	2518	2091	1725	1450	1200	1030	910
Airfoil—housed										
Diameter	13.22	14.56	16.19	19.69	21.56	24.00				
Maximum rpm Class I	3000	3000	2300	2000	1700	1500				
Maximum rpm Class II	4335	3918	3457	2858	2427	2255				

Table 16: Unit Sizes 040 to 090

Fan operating limits								
Forward curved—housed								
Diameter	20	22.38	25	27.62	30.25	33	36	
Maximum rpm Class I	1010	930	790	690	650	600	560	
Maximum rpm Class II	1281	1178	1011	910	835	763	715	
Airfoil—housed								
Diameter	20	22.25	24.5	27	30	33	36.5	
Maximum rpm Class I	2077	1875	1691	1479	1328	1209	1073	
Maximum rpm Class II	2703	2413	2199	1928	1730	1579	1401	

Table 17: Operating Limits—Belt-Drive Plenum Fans

Fan Operating Limits																
Belt-Drive Plenum Fans																
Size	13	15	16	18	20	22	24	27	30	33	36	40	44	49	54	60
Maximum rpm Class II	3909	3468	2820	2930	2674	2403	2183	1860	1783	1620	1465	1329	1202	1091	986	891
Maximum rpm Class III	4000	4000	3887	3735	3409	3065	2780	2423	2182	1984	1759	1598	1447	1314	1178	1071

Table 18: Operating Limits—Inline Fans, Twin Fans

Fan Operating Limits													
Inline fans													
Diameter	18.25	20	22.25	24.5	27	30	33	36.5	40.25	44.50	49	54.25	
Maximum rpm Class I	2727	2488	2236	2041	1835	1665	1476	1330	1208	1072	973	880	
Maximum rpm Class II	3409	3111	2796	2551	2294	2082	1846	1662	1510	1340	1216	1100	
Twin fans													
Diameter	9 x 9	10.62	12.62	15	18.12	20							
Maximum rpm	2575	2400	2000	1700	1400	1200							
Maximum HP	10	15	15	30	40	40							

Table 19: Operating Limits—Direct-Drive Plenum Fans

Fan Operating Limits																		
Belt-Drive Plenum Fans																		
Size	11	12	13	15	16	18	20	22	24	27	30	33	36	40	44	49	54	60
Maximum rpm Class II	4000	4000	—	3909	3650	3650	2674	2403	2183	1981	1783	1620	1465	1329	1202	—	—	—
Maximum rpm Class III	—	—	4000	4000	3887	3735	3409	3065	2780	2423	2182	1984	1759	1598	1447	1314	1178	1071

Operation Guidelines

Fan Vibration Levels

Each unit as shipped is trim balanced to operate smoothly. To provide satisfactory operation after shipping and installation, use the accepted industry guidelines for field balancing fans. See [Table 20](#).

Table 20: Vibration Levels

Fan speed (rpm)	Vibration
800 or less	5 mils maximum displacement
801 or greater	0.20 in/sec. maximum velocity

Note: Excessive vibration from any cause contributes to premature fan and motor bearing failure. Monitor overall vibration levels every six months of operation. An increase in levels is an indication of potential trouble.

Vibration Causes

- 1 Wheel imbalance.
 - a Dirt or debris on wheel blades.
 - b Loose set screws in wheel hub or bearing-to-shaft.
 - c Wheel distorted from overspeed.
- 2 Bent shaft.
- 3 Drive faulty.
 - a Variable pitch sheaves—Axial and radial runout of flanges; uneven groove spacing; out of balance. Also similar faults in driven sheave.
 - b Bad V-belts; lumpy, or mismatched; belt tension too tight or too loose.
- 4 Bad bearings, loose bearing hold-down bolts
- 5 Motor imbalance
- 6 Fan section not supported evenly on foundation

Periodic Maintenance

- 1 Check all moving parts for wear every six months.
- 2 Check bearing collar, sheave, and wheel hub setscrews, sheave capscrews, and bearing hold-down bolts for tightness every six months.
- 3 Annually check and snug all electrical connections. Inspect for signs of water damage such as corrosion and repair if necessary. Check ground conductor and connection integrity. Service if needed.

Ball Bearing Lubrication

CAUTION

Bearing overheating potential. Can damage the equipment. Do not overlubricate bearings. Use only a high grade mineral grease with a 200°F safe operating temperature. See below for specific recommended lubricants.

Motor Bearings

Supply and return fans—Supply and return fan motors should have grease added after every 2000 hours of operation. Using the following procedure, relubricate the bearings while the motor is warm, but not running. Use one of the greases shown in [Table 21](#).

Note: Direct Drive Class II fans that are supplied with TECO motors have double shielded bearings on frame sizes 140T-280T. These bearings are pre-packed with a long life grease and are not regreaseable. Larger frame size TECO motors are regreaseable and follow the same lubrication recommendations as all other motors.

Table 21: Recommended Lubricants and Amounts for Fan Motor Bearings

Mfr. Grease	NEMA Size	Amount to Add (oz.)
Texaco, Polystar or Polyrex EM (Exxon Mobile) or Rykon Premium #2 or Penzoil Pen 2 Lube	56 to 140	0.08
	140	0.15
	180	0.19
	210	0.30
	250	0.47
	280	0.61
	320	0.76
	360	0.81
	400	1.25
440	2.12	

- 1 Remove and clean upper and lower grease plugs.
- 2 Insert a grease fitting into the upper hole and add clean grease ([Table 21](#)) with a low pressure gun.
- 3 Run the motor for five minutes before replacing the plugs.

Note: Specific greasing instructions are located on a tag attached to the motor. If special lubrication instructions are on the motor, they supersede all other instructions.

Fan Shaft Bearings

Any good quality lithium or lithium complex base grease, using mineral oil, conforming to NLGI grade 2 consistency, and an oil viscosity of 455-1135 SUS at 100°F (100-200 cSt at 40°C) may be used for relubrication.

Compatibility of grease is critical. Relubricatable bearings are supplied with grease fittings or zerks for ease of lubrication with hand or automatic grease guns. Always wipe the fitting and grease nozzle clean.

CAUTION

For safety, stop rotating equipment. Add one half of the recommended amount shown in [Figure 24](#). Start bearing, and run for a few minutes. Stop bearing and add the second half of the recommended amount. A temperature rise, sometimes 30°F (1°C), after relubrication is normal. Bearing should operate at temperature less than 200°F (94°C) and should not exceed 225°F (107°C) for intermittent operation. For a relubrication schedule, see [Table 22](#). For applications that are not in the ranges of the table, contact McQuay.

CAUTION

The tables below state general lubrication recommendations based on our experience and are intended as suggested or starting points only. For best results, specific applications should be monitored regularly and lubrication intervals and amounts adjusted accordingly.

Table 22: Relubrication Intervals

(Use NLGI #2 Lithium or Lithium Complex Grease)			
Speed	Bearing Temperature	Cleanliness	Relub. intervals
100 rpm	Up to 120°F (50°C)	Clean	6 to 12 months
500 rpm	Up to 150°F (65°C)	Clean	2 to 6 months
1000 rpm	Up to 210°F (100°C)	Clean	2 weeks to 2 months
1500 rpm	Over 210°F (100°C) to 250°F (120°C)	Clean	Weekly
Above 1500 rpm	Up to 150°F (65°C)	Dirty/wet	1 week to 1 month
Max catalog rating	Over 150°F (65°C) to 250°F (120°C)	Dirty/wet	Daily to 2 weeks
	Above 250°F (120°C)		Contact Browning

Service and Maintenance

Table 23: Recommended Lubricants for Fan Shaft Ball Bearings

Name	Temperature	Base	Thickener	NLGI grade
Texaco, Premium RB	30° to 350°F (34° to 177°C)	Parafinic mineral oil	Lithium	2
Mobile, AW2	40° to 437°F (40° to 175°C)	Mineral oil	Lithium	2
Mobile, SHC 100	68° to 356°F (50° to 180°C)	Synthetic	Lithium	2
Chevron, Altiplex Synthetic	60° to 450°F (51° to 232°C)	Synthetic	Lithium	2
Exxon, ronex MP	40° to 300°F (40° to 149°C)	Mineral oil	Lithium	2

Note: Temperature ranges over 225°F are shown for lubricants only. High temperature applications are not suitable for standard air handler components.

Table 24: Recommended Fan Relubrication Grease Charge

Shaft Size (in)	OZ.	Shaft Size	Grams
1/2 to 3/4	0.03	20 mm	0.85
7/8 to 1-3/16	0.10	25-30 mm	2.84
1-1/4 to 1-1/2	0.15	35-40 mm	4.25
1-11/16 to 1-15/16	0.20	45-50 mm	5.67
2 to 2-7/16	0.30	55-60 mm	8.51
2-1/2 to 2-15/16	0.50	65-70 mm	15.59
3 to 3-7/16	0.85	75-80 mm	24.10
3-1/2 to 4	1.50	85-105 mm	42.53

Fan Drive

WARNING

Before servicing fans, lock out and tag out all power to the unit. Fans or belts can cause severe personal injury or death.

AVERTISSEMENT

Avant de faire le service sur les ventilateurs, couper et indiquer que le courant est coupé. Les ventilateurs ou les courroies peuvent causer des blessures personnelles graves ou entraîner la mort.

WARNING

Do not open the hinged access door and screw-fastened access panels while the unit is operating. Moving parts and strong suction forces can cause severe personal injury or death.

AVERTISSEMENT

Ne pas ouvrir les portes d'accès à charnières et les panneaux à vis lorsque l'unité fonctionne. Les pièces mobiles et le niveau de succion peuvent causer des blessures personnelles graves ou même entraîner la mort.

Upon completion of the air balance, replace the variable pitched motor sheave with a properly sized, fixed sheave. A matching fixed sheave provides longer belt and bearing life and minimizes vibration. Initially, it is best to have a variable pitched motor sheave for the purpose of air balancing. Once the balance is achieved, fixed sheaves maintain balancing and alignment more effectively. Replace the adjustable sheaves with fixed sheaves.

With the electrical power disconnected, locked and tagged out, measure the diameter of the V-belt outer surface where it passes around the sheave (pitch diameter). Calculate fan speed from the motor nameplate rpm.

$$\text{Fan rpm} = \text{motor rpm} \times \frac{\text{Measured diameter at motor sheave}}{\text{Measured diameter at fan sheave}}$$

VM and VP Variable Pitch Key Type Sheaves

Mounting

- 1 Mount all sheaves on the motor or driving shaft with the setscrews **A** toward the motor.
- 2 Verify that both driving and driven sheaves are in alignment and that shafts are parallel.
- 3 Fit internal key **D** between sheave and shaft and lock setscrew **A** securely in place.

Adjusting

- 1 Loosen setscrews **B** and **C** in moving parts of sheave and pull out external key **E**. (This key projects a small amount to provide a grip for removing.)
- 2 To adjust sheave pitch diameter for desired speed, open moving parts by half or full turns from closed position. **Do not open more than five full turns for A belts or six full turns for B belts.**
- 3 Replace external key **E** and securely tighten setscrews **B** over key and setscrews **C** into keyway in fixed half of the sheave.
- 4 Put on belts and adjust belt tension. **Do not force belts over grooves.** See [Fan Drive Belt Adjustment, page 30](#).
- 5 Make future adjustments by loosening the belt tension and increasing or decreasing the pitch diameter of the sheave by half or full turns as required. Readjust belt tension before starting drive.
- 6 To provide the same pitch diameter, adjust both halves of the two-groove sheaves by the same number of turns from closed position.
- 7 Verify that all keys are in place and that all set screws are tight before starting drive. Check setscrews and belt tension after 24 hours service.

Figure 35: VP Type Sheave Adjustment

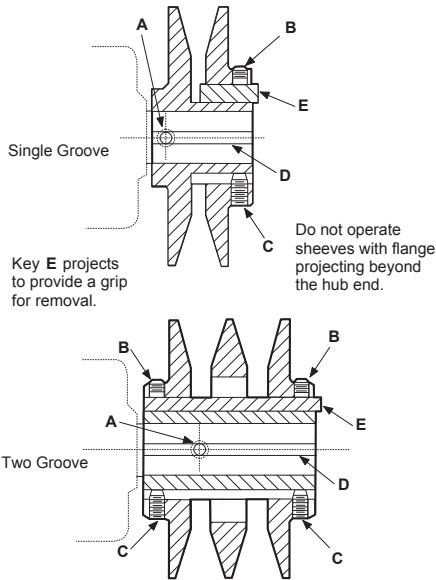

LVP Variable Speed Sheaves

Mounting

- 1 Slide sheave on motor shaft so that the side of the sheave with setscrew **A** is next to the motor when setscrew **A** is in the hub or barrel of the sheave.
- 2 When setscrew **A** is at an angle in the center flange **B**, mount it away from the motor so that the outer locking ring and flange can be removed to get to the setscrew.
- 3 To remove the flange and locking ring:
 - a Loosen setscrews **D**.
 - b Loosen but **do not remove** capscrews **E**.
 - c Remove key **F**.

Note: This key projects a small amount to provide a grip for removing.

- d Rotate the flange counterclockwise until it disengages the threads on the sheave barrel.
- 4 Verify that the driving and driven sheaves are in alignment and the shafts are parallel. When aligning two-groove sheaves, allow room between the sheave and motor to access capscrews **E**.
- 5 Insert key **C** between the sheave and the shaft and tighten setscrew **A** securely.
- 6 If flange and locking ring have been removed, when replacing them make sure that the inner and outer flanges are open from the closed position by the same amount as the other flange. Determine this by accurately measuring the top width of the grooves.
- 7 Insert key **F**.

- 8 Tighten setscrews **D** and capscrews **E**.
- 9 Put on belts and adjust belt tension. **Do not force belts over grooves.** See [Fan Drive Belt Adjustment](#), page 30.
- 10 Before starting the drive, ensure that all keys are in place and all setscrews and all capscrews are tight. Check and retighten all screws and retention belts after approximately 24 hours of service.

Adjusting

- 1 Slack off belt tension if belts have been installed.
 - 2 Loosen setscrews **D**.
 - 3 Loosen but **do not remove** capscrews **E**.
 - 4 Remove key **F**.
- Note:** This key projects a small amount to provide a grip for removing.
- 5 Adjust pitch diameter by opening or closing the movable flanges by half or full turns.
- Note:** Two-groove sheaves are supplied with both grooves set at the same pitch diameter.
- 6 To provide the same pitch diameter for satisfactory operation, move both movable flanges the same number of turns. Do not open sheaves more than five turns for **A** belts or six turns for **B** belts.
 - 7 Replace key **F**.
 - 8 Tighten setscrews **D** and capscrews **E**.
 - 9 If belts have been installed, readjust belt tension. If belts have not been installed, install them and adjust belt tension. **Do not force belts over grooves.** See [Fan Drive Belt Adjustment](#), page 30.
 - 10 Before starting the drive, ensure that all keys are in place and all setscrews and all capscrews are tight. Check and retighten all screws and retention belts after approximately 24 hours of operation.

Figure 36: LVP Type Sheave Adjustment

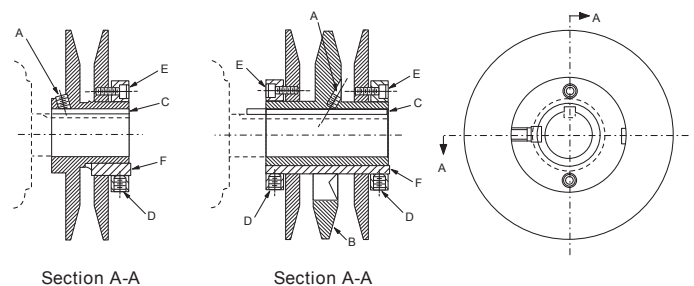

Service and Maintenance

MVP Variable Speed Sheaves

Mounting

- 1 Verify both driving and driven sheaves are in alignment and the shafts are parallel. The centerline of the driving sheave must be in line with the centerline of the driven sheave. See [Figure 37](#).
- 2 Verify that all setscrews are torqued to the values shown in [Table 25](#) before starting drive. Check setscrew torque and belt tension after 24 hours of service.

Adjusting

- 1 Adjust motor base forward to release belt tension. Remove the belts for easier adjustment.
- 2 Loosen, but do not remove both of the locking setscrews **A** in the outer locking ring by using a hex key or torque wrench with a hex bit.
- 3 Adjust sheave to desired pitch diameter by turning the outer locking ring. Use a spanner wrench or drift inserted into the three holes that are located 120° apart on the ring.

- 4 Any pitch diameter can be obtained within the sheave range. One complete turn of the outer locking ring changes the pitch diameter 0.233".
- 5 Do not open sheaves more than the following:
 - a Do not open **B** sheaves more than 4 3/4 turns for the **A** belts or 6 turns for the **B** belts.
 - b Do not open **C** sheaves more than 9 1/2 turns.
 - c Do not open **5V** sheaves more than 6 turns.
 - d Do not open **8V** sheaves more than 8 turns.
- 6 Tighten BOTH locking screws **A** in the outer locking ring before operating the drive. Use a torque wrench and tighten to the value shown in [Table 25](#).
- 7 Replace belts and adjust the motor base to tension the belts properly. See [Fan Drive Belt Adjustment, page 30](#).
- 8 Do not loosen any screws other than the two locking screws **A** in the outer locking ring when adjusting the sheave pitch. Do not operate the drive until the locking screws have been set to the torque specifications.

Table 25: Screw Torque Values

Nominal screw size (dia—thds/in)	Socket head cap screws		Flat head socket screws	Hollow head set screws only			
	Seating torque			Lengths equal or greater than dia.		For lengths (L) less than dia.	
	(in-lbs)	(in-lbs)	Seating torque (in-lbs)	Seating torque (in-lbs)	Seating torque (in-lbs)	Length (L) (in-lbs)	Seating torque (in-lbs)
1/4-20NC	150	12.5	100	87	7.3	3/16	50
5/16-11NC	305	25.4	200	165	13.8	1/4	90
3/8-16NC	545	45.4	350	290	24.2	1/4, 5/16	150, 250
1/2-13NC	1300	108.3	N/A	620	51.7	N/A	N/A
5/8-11NC	N/A	N/A	N/A	1225	102.1	N/A	N/A

Figure 37: Sheave Adjustment

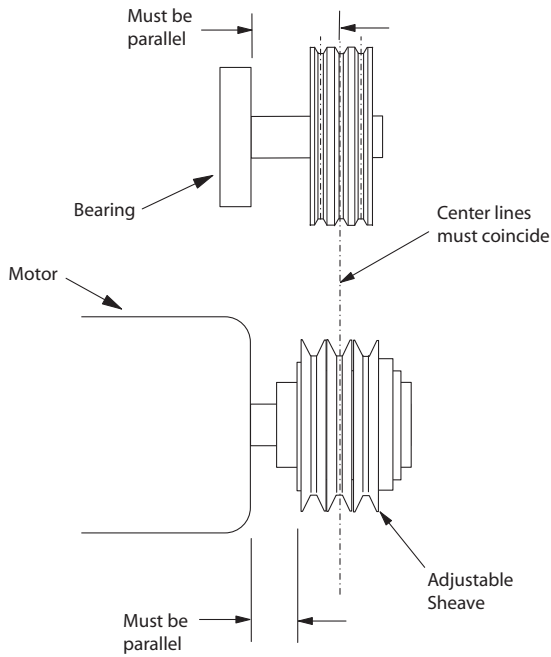
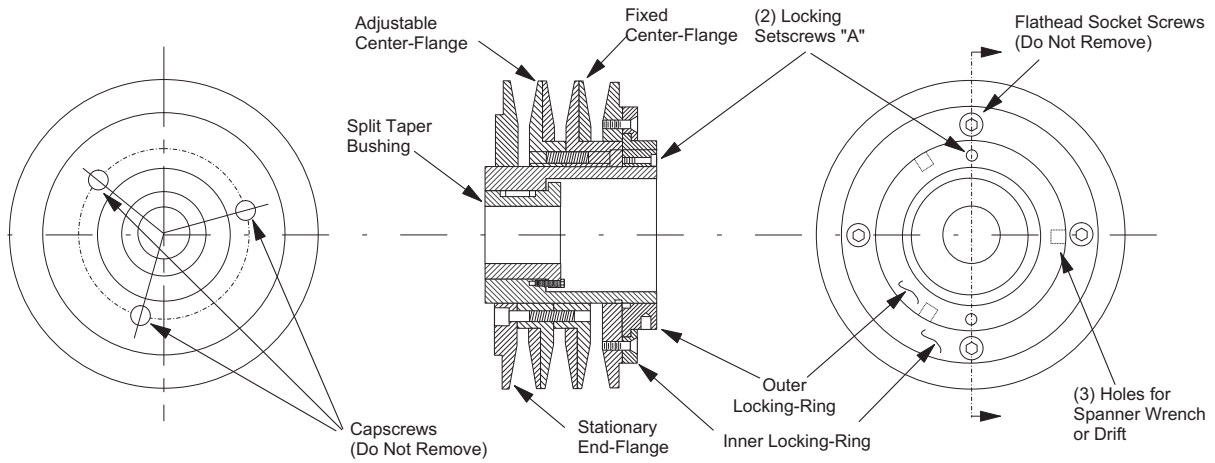

Figure 38: Sheave Adjustment



Service and Maintenance

Fan Drive Belt Adjustment

General Rules of Tensioning

- 1 The ideal tension is the lowest tension at which the belt does not slip under peak load conditions.
- 2 Check tension frequently during the first 24 to 48 hours of operation.
- 3 Over tensioning shortens belt and bearing life.
- 4 Keep belts free from foreign material that can cause slippage.
- 5 Inspect V-drive on a periodic basis. Adjust tension if the belt is slipping. Do not apply belt dressing. This can damage the belt and cause early failure.

Tension Measurement Procedure

- 1 Measure the belt span. See Figure 39.
- 2 Place belt tension checker squarely on one belt at the center of the belt span. Apply force to the checker, perpendicular to the belt span, until the belt deflection equals belt span distance divided by 64. Determine the force applied while in this position.
- 3 Compare this force to the values in Table 26.

Figure 39: Drive Belt Adjustment

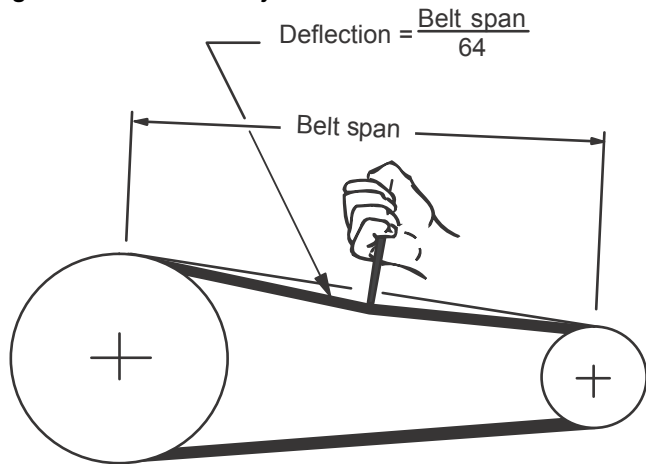

Table 26: Belt Deflection Force (per Browning Specifications)

Cross section	Small sheave diameter (in)	Number of belts (deflection force lbs)					
		1		2		3 +	
		min	max	min	max	min	max
A, AX	0.0 to 3.5	3.0	5.0	2.5	4.0	2.0	3.5
	3.6 to 4.4	3.5	5.0	3.0	4.5	2.0	4.0
	4.5 +	4.0	5.5	3.0	5.0	2.5	4.5
B, BX	0.0 to 5.4	5.5	8.0	4.5	7.0	3.5	5.5
	5.5 to 7.6	5.5	8.5	4.5	7.5	3.5	5.5
	7.7 +	6.5	9.0	5.0	8.0	4.0	6.5
5V, 5VX	0.0 to 8.5	7.0	11.0	5.5	9.0	4.0	7.0
	8.6 TO 12.0	8.5	13.0	6.5	10.5	5.0	8.0
	12.1 +	10.0	15.0	7.5	11.5	5.5	9.0

WARNING

Moving belt and fan can cause severe personal injury or death. During installation and filter maintenance:

- Verify that the belt and fan guards on plenum fan units are always in place.
- Lock and tag out fans to prevent accidental start up.
- Do not enter the filter compartment until the fan is completely stopped.
- Use approved equipment for reaching filters located above normal reach. Do not step on filter frames or unit components.
- Floor surfaces must be dry and free of oil or grease.

WARNING

Pendant l'installation et où l'entretien des filtres, un courroie en mouvement ou un ventilateur en opération peuvent causer des blessures graves où même causer la mort.

- S'assurer que les gardes de courroie et de ventilateur sont toujours en place.
- Verrouiller les démarreurs des ventilateurs et afficher un avis de mise-en-garde afin de prévenir tout accident ou démarrage.
- Attendre que le ventilateur soit complètement arrêté avant d'entrer dans l'unité.
- Utiliser seulement des équipements approuvé pour joindre les bancs de filtres; ne pas mettre soit sur les cadres des filtres ou même sur toutes composantes de l'unité.
- La surface des planchers doit être sec et libre de toute trace d'huile et où de graisse.

Front Load Filter Option

Front loaded filter options require that the filters be removed and replaced from inside the unit.

To remove filters, rotate the wire clips. This releases both the prefilter and the final filter. When installing clean filters, check to verify the filters are fully seated in the frame (Figure 40).

Figure 40: Frame and Filters with Holding Clips

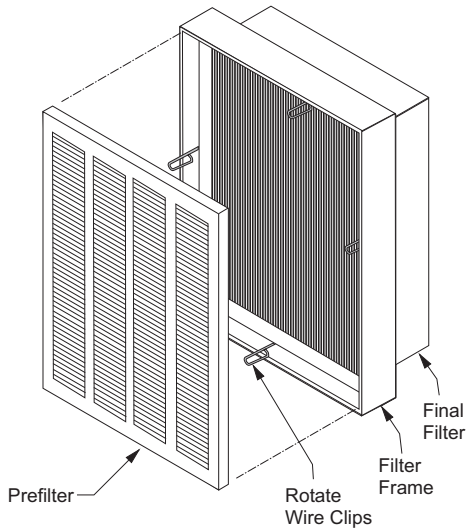

Filter Gauges

Filter gauges indicate pressure drop for installed filters. If prefilters are present, the gauge will indicate the pressure drop for both pre- and final filters

Table 27 shows the typical filter pressure drop for clean filters at rated air flow. The tables also show a final pressure drop for front loaded filters.

Where a single filter gauge is used, the prefilters can be removed to check the pressure drop of the final filters.

Figure 41: Filter Gauge



Table 27: Filter Pressure Drops

Bag filters—DriPak 2000				
Efficiency	45%	65%	85%	95%
Rated velocity (fpm)	625	500	500	500
Initial pressure drop	.20–.26	.21–30	.34–.48	.50–.70
Initial pressure drop	1.0	1.0	1.0	1.0
Cartridge filters—Varicel II MH, 4.25" deep				
Efficiency	65%	85%	95%	Efficiency
Rated velocity (fpm)	500	500	500	Rated velocity (fpm)
Initial pressure drop	.43	.61	.70	Initial pressure drop
Final pressure drop	1.5	1.5	1.5	Final pressure drop
Cartridge filters—Varicel SH, 12" deep				
Efficiency	70%			
Rated velocity (fpm)	500			
Initial pressure drop	.39			
Final pressure drop	1.2			
Pleated panel filters				
Type	Perfect pleat	AMAir 300 4"		
Efficiency	30%	30%		
Rated Velocity (fpm)	500	625		
Initial Pressure Drop	.36	.36		
Final Pressure Drop	1.0	1.0		
5700 filters				
Efficiency	N/A			
Rated velocity (fpm)	500			
Initial pressure drop	.25			
Final pressure drop	1.0			
Pleated 62 Plus filters				
Size	2"	4"		
Efficiency	70%	70%		
Initial pressure drop	.42	.37		
Final pressure drop	1.0	1.0		

Service and Maintenance

Coils

- 1 The coil must be clean to obtain maximum performance. Check once a year under normal operating conditions and, if dirty, brush or vacuum clean. Use a chemical coil cleaner on multiple row coils. Read and follow the chemical cleaner's instructions as some cleaners may contain harsh chemicals. Take care not to damage fins while cleaning.
- 2 Drain pans in any air conditioning unit may have some moisture. Algae, etc., can grow due to airborne spores and bacteria. Periodic cleaning is necessary to prevent this buildup from plugging the drain and causing the drain pan to overflow. Also, keep the drain pans clean to prevent the spread of disease. Cleaning should be performed by qualified personnel.
- 3 Dirt and lint can clog the condensate drain, especially with dirty filters. Inspect twice a year to help avoid overflow.

Winterizing Water Coils

Coils can freeze due to air stratification or failure of outdoor air dampers and/or preheat controls. Do not depend on routine draining of water cooling coils for winter shutdown as insurance against freeze-up. Severe coil damage can result. Drain all coils as thoroughly as possible and then treat in the following manner.

- Fill each coil independently with an antifreeze solution using a small circulating pump and again thoroughly drain.
- Check freezing point of antifreeze before proceeding to next coil. Due to a small amount of water always remaining in each coil, there is a diluting effect. The small amount of antifreeze solution remaining in the coil must always be concentrated enough to prevent freeze-up.

Note: Carefully read instructions for mixing antifreeze solution used. Some products have a higher freezing point in their natural state when mixed with water. **McQuay International is not responsible for the freezing of coils.**

WARNING

Mold can cause personal injury. Clean drain pan regularly so mold does not develop.

AVERTISSEMENT

La moisissure présente un danger respiratoire. Pour éviter la moisissure, nettoyer régulièrement le bassin de drainage.

Removing and Replacing Components

See [Access Doors and Panels, page 8](#) for instructions on removing panels and opening fan access doors to remove or replace components.

WARNING

Before removing any component, lock out and tag out all power to the unit. Fans and belts can cause severe personal injury or death.

AVERTISSEMENT

Avant d'enlever toute composante, couper et indiquer que l'alimentation électrique à l'unité est coupée. Les ventilateurs et les courroies peuvent entraîner des blessures personnelles graves ou même la mort.

Removing the Fan Section

The fan shaft, motor, and any drive components can be removed and replaced through the access door opening. If required, the side panel can be removed for additional access.

If fan replacement is required, the entire fan assembly can be pulled out the side of the cabinet for housed fan assemblies. The fan assembly includes the fan housing, the bearing support, and the fan base.

Removing the Fan Assembly

- 1 Remove the side panels and any intermediate supports (follow instructions for side panel removal).
- 2 Once the panels and any intermediate supports are removed, disconnect the neoprene bulk head seal that is attached to the fan discharge.
- 3 Remove the four discharge angles that hold the neoprene canvas in place around the discharge opening.
- 4 Disconnect the fan sled from each of the corner mounts and pull the entire assembly out the side of the unit.
- 5 After the fan sled is out, loosen the fan bearings and pull out the shaft.
- 6 Disconnect the fan housing from the fan sled, and bearing support by removing the attaching bolts.
- 7 Replace the new fan, reconnect the shaft and bearings and put the fan assembly in the cabinet.
- 8 Replace panels and fasteners.

Removing the Fan Section

For plenum fan assemblies, the entire fan cabinet may need to be removed to replace the entire fan assembly depending on the length of the fan section. In some cases, the fan section is not long enough for the assembly to fit out the side of the cabinet. For those cases where it will fit, follow the above steps except the neoprene seal is a D-gasket on the inlet side that needs to be removed for plenum fans. Otherwise, the entire fan cabinet must be removed from the other sections and then the fan assembly can be removed out the discharge side of the cabinet.

Removing and Replacing the Coil

Removing Single Coils

Note: Single coils are bolted to the unit on the connection end. The connection end is held in place with a clamp.

- 1 Disconnect all piping and remove the brass plugs for the vents and drains located in the connections.
- 2 Remove all screws and remove the access panel.
- 3 Remove the screws holding the coil in place.
- 4 Lift and pull the coil out the side.

Installing Single Coils

- 1 Slide the coil through the opening in the coil section onto the bottom coil rests.
- 2 To prevent any air bypass around the coil, place coils up against the coil bulkheads. See [Single Coil Top Installation/Removal, page 33](#).
- 3 Once the coil is in place, fasten the coil to the section.
- 4 Caulk the seams between the coil casings and bulkheads.
- 5 If this is an additional coil being installed and not a replacement, locate the coil supply and return connections dimensionally. Carefully drill holes in the end panels of the unit.
- 6 Remove the brass plugs for the vents and drains on the connections.
- 7 Slip the panel over the connections.
- 8 Replace the brass plugs and panel fasteners.

Figure 42: Single Coil Top Installation/Removal

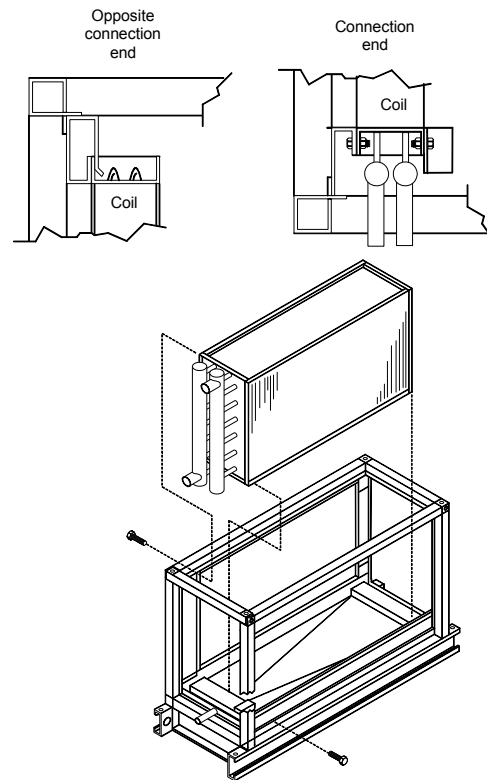
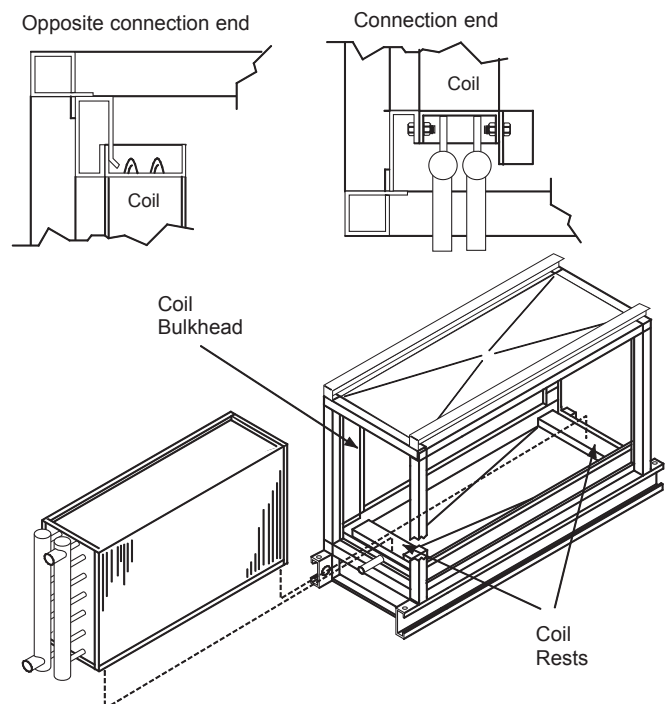

Figure 43: Single Coil Side Installation/Removal



Service and Maintenance

Removing Stacked Coils

Note: Top and bottom stacked coils are held together with steel plate and screws on one side and drain trough and screws on the other side. Remove the plate and trough before removing the coils. The coils cannot be removed attached together.

- 1 Disconnect all piping and remove the brass plugs for the vents and drains located in the connections.
- 2 Remove all screws and remove the access panel.
- 3 Remove the bolts holding the coil in place and then lift and pull out the coil from the side.
- 4 Remove the steel plate and the drain trough that holds the coils together.
- 5 Remove the bolts on both ends of the top coil holding it in place and then lift and slide the coil out.
- 6 Remove the bolts on both ends of the bottom coil holding it in place and then lift and slide the coil out.

Installing Stacked Coils

- 1 Slide the bottom coil through the opening in the coil section onto the bottom coil rests.
- 2 Place the coil up against the coil bulkheads to prevent any air bypass around the coil.
- 3 Once the coil is in place, bolt the coil to the section.
- 4 Caulk the mounting surface of the steel plate and install the plate on the coils.
- 5 Caulk the mounting surface of the drain trough and install the drain trough on the coils.
- 6 Caulk the seams between the coil casings and blockoffs.
- 7 Connect all piping and install the brass plugs for the vents and drains located in the connections.
- 8 Install the access panel.

Removing and Installing Staggered Coils

Staggered coils have two banks of coils positioned a few inches apart in the direction of airflow. Both coils are secured to the unit on the connection and opposite connection end of the unit.

- 1 Disconnect all piping and remove the brass plugs for the vents and drains located in the connections.
- 2 To access bolts holding the coils in place, remove the panels on both the connection and opposite connection end of the coil section.
- 3 Each coil is held in place with bolts located in the corners of the coil side plates. Remove the bolts and then lift and pull the coil out the side.
- 4 The bottom coil is fastened to the air block off plate. Remove the screws attaching this plate to the coil.
- 5 Once the fasteners holding the coil in place are removed, pull out the coil from either side of the unit.
- 6 Install the coils in reverse order of removal.

Replacement Parts

When writing to McQuay for service or replacement parts, refer to the model number and serial number of the unit stamped on the serial plate attached to the unit. If replacement parts are required, mention the date of installation of the unit and date of failure, along with an explanation of the malfunctions and a description of the replacement parts required.

Service and Warranty Procedure

Warranty

Consult your local McQuay Representative for warranty details. Refer to Form 933-43285Y. To find your local McQuay Representative, go to www.mcquay.com.

Warranty Return Material Procedure

Defective material may not be returned without permission of authorized factory service personnel of McQuay International in Minneapolis, Minnesota, (763) 553-5330. A “Return Goods” tag must be included with the returned material. Enter the required information to expedite handling and prompt issuance of credits. All parts must be returned to the

appropriate McQuay facility, designated on the “Return Goods” tag. Transportation charges must be prepaid.

The return of the part does not constitute an order for replacement. Therefore, a purchase order must be entered through the nearest McQuay representative. The order should include part number, model number, and serial number of the unit involved.

Credit will be issued on customer's purchase order following an inspection of the return part and upon determination that the failure is due to faulty material or workmanship during the warranty period.



To comply with the terms of McQuay Warranty, complete and return this form within 10 days to McQuay Warranty Department.

Check, test, and start procedure for McQuay Air Handling Units with or without heat recovery.

Job Name: _____ McQuay S.O. No.: _____ McQuay G.O. No.: _____

Installation address: _____

City: _____ State: _____

Purchasing contractor: _____

City: _____ State: _____

Name of Person doing start-up (print) _____

Company name _____

Address _____

City/State/Zip _____

Unit model number: _____ Unit serial number: _____

SF VFD model number: _____ Serial number: _____ N/A

RF VFD model number: _____ Serial number: _____ N/A

Circle Yes or No. If not applicable to the type of unit, circle N/A.

I. INITIAL CHECK

- A. Is any shipping damage visible? ... Yes No N/A
B. Are fan drives properly aligned and belts properly adjusted? ... Yes No N/A
C. Tightened all setscrews on pulleys, bearings and fans? ... Yes No N/A
D. Have the hold-down bolts been backed off on spring mounted fan isolators? ... Yes No N/A
E. With power off, do fans turn freely by hand? ... Yes No N/A
F. Electrical service corresponds to unit nameplate? ... Yes No N/A
Volts _____ Hertz _____ Phase _____
G. Is the main disconnect adequately fused and are fuses installed? ... Yes No N/A
H. Are all electrical power connections tight? ... Yes No N/A
I. Is the condensate drain trapped? ... Yes No N/A
J. Fill drain pan. Does water drain freely? ... Yes No N/A
K. Is the unit mounted level? ... Yes No N/A

II. FAN DATA

- A. Check rotation of supply fan. ... Yes No N/A
B. Voltage at supply fan motor: 1-2 _____ V 2-3 _____ V 1-3 _____ V
C. Supply fan motor amp draw per phase: L1 _____ L2 _____ L3 _____
D. Overload amp setting: _____
E. What is the supply fan rpm? _____
F. Check rotation of return fan ... Yes No N/A
G. Voltage at return fan motor: 1-2 _____ V 2-3 _____ V 1-3 _____ V
H. Return fan motor amp draw per phase: L1 _____ L2 _____ L3 _____
I. Overload amp setting: _____
J. What is the return fan rpm? _____
K. Record supply static pressure at unit discharge: _____ inches of H2O
L. Record return static pressure at unit (with outside air dampers closed) _____ inches of H2O

III. DAMPERS

- A. Are blades and seals present? ... Yes No N/A
B. Do dampers open smoothly and shut tight? ... Yes No N/A

IV. ELECTRIC HEAT

- A. Electrical heat service corresponds to unit nameplate? ... Yes No N/A
_____ Volts _____ Hertz _____ Phase
B. Are there any signs of physical damage to the electric heat coils? ... Yes No N/A
C. Have all electrical terminals been tightened? ... Yes No N/A
D. Does sequence controller stage contactors properly? ... Yes No N/A
E. Electric heater voltage across each phase: L1-2 _____ V L2-3 _____ V L1-3 _____ V
F. Amp draw across each phase at each heating stage:
Stage 1 Stage 2 Stage 3 Stage 4 Stage 5 Stage 6
Phase L1: _____

Check, Test, and Start Procedure Form

Phase L2: _____

Phase L3 _____

G. FLA: L1 _____ L2 _____ L3 _____

H. Operate electric heat with fans off. Electric heat must cycle OFF on high limit control. Yes No N/A

V. CHILLED WATER COIL

A. Pressure test okay? Yes No N/A

B. Drain pan draining okay? Yes No N/A

VI. HOT WATER COIL

A. Pressure test okay? Yes No N/A

VII. HEAT RECOVERY

A. Heat wheel rotates freely? Yes No N/A

B. Heat wheel VFD operates properly? Yes No N/A

C. Heat wheel VFD model # _____ serial #: _____ N/A

D. Check for air bypass around heat wheel Yes No N/A

Yes No N/A

Yes No N/A

Signature: _____

Startup date: _____

RETURN COMPLETED FORM WITHIN 10 DAYS OF START-UP TO:

McQuay International Warranty Department, 13600 Industrial Park Boulevard, Minneapolis, MN 55441

Please list any additional comments that could affect the operation of this unit; e.g., shipping damage, failed components, adverse installation applications, etc., on a separate sheet and attach to this form.

Quality Assurance Survey Report

Quality Assurance Survey Report

To whom it may concern:

Please review the items below upon receiving and installing our product. Mark N/A on any item that does not apply to the product.

Job Name: _____ McQuay G.O. no. _____

Installation Address: _____
 City: _____ State: _____

Purchasing Contractor: _____
 City: _____ State: _____

Name of person doing start-up (print): _____

- | | | | |
|---|-----|----|--------|
| 1. Is there any shipping damage visible? | Yes | No | N/A |
| __ Location on unit _____ | | | |
| 2. How would you rate the overall appearance of the product; i.e., paint, fin damage, etc.? | | | |
| Excellent Good Fair | | | Poor |
| 3. Did all sections of the unit fit together properly? | Yes | No | N/A |
| 4. Did the cabinet have any air leakage? | Yes | No | N/A |
| Location on unit _____ | | | |
| 5. Were there any refrigerant leaks? | Yes | No | N/A |
| Shipping Workmanship | | | Design |
| 6. Does the refrigerant piping have excessive vibration? | Yes | No | N/A |
| Location on unit _____ | | | |
| 7. Did all of the electrical controls function at start-up? | Yes | No | N/A |
| Comments _____ | | | |
| 8. Did the labeling and schematics provide adequate information? | Yes | No | N/A |
| 9. How would you rate the serviceability of the product? | | | |
| Excellent Good Fair | | | Poor |
| 10. How would you rate the overall quality of the product? | | | |
| Excellent Good Fair | | | Poor |
| 11. How does the quality of McQuay products rank in relation to competitive products? | | | |
| Excellent Good Fair | | | Poor |

Comments:

Please list any additional comments which could affect the operation of this unit; i.e., shipping damage, failed components, adverse installation applications, etc. If additional comment space is needed, write the comment(s) on a separate sheet, attach the sheet to this completed Quality Assurance Survey Report, and return it to the Warranty Department with the completed preceding "Equipment Warranty Registration Form".

McQuay Training and Development

Now that you have made an investment in modern, efficient McQuay equipment, its care should be a high priority. For training information on all McQuay HVAC products, please visit us at www.mcquay.com and click on training, or call 540-248-9646 and ask for the Training Department.

Warranty

All McQuay equipment is sold pursuant to its standard terms and conditions of sale, including Limited Product Warranty. Consult your local McQuay Representative for warranty details. Refer to Form 933-430285Y. To find your local McQuay Representative, go to www.mcquay.com.

Aftermarket Services

To find your local parts office, visit www.mcquay.com or call 800-37PARTS (800-377-2787). To find your local service office, visit www.mcquay.com or call 800-432-1342.

This document contains the most current product information as of this printing. For the most up-to-date product information, please go to www.mcquay.com.

