

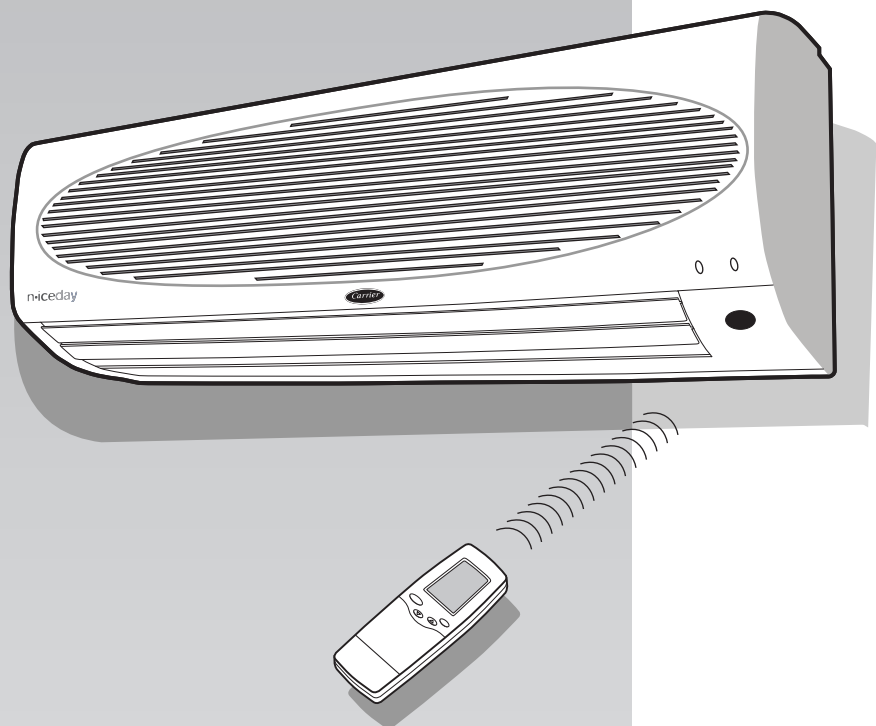

42PHQ---N

niceday



INSTALLATION MANUAL

42PHQ---N

Split system “Hi-Wall” indoor unit

For operation and maintenance instructions of this unit, as well as installation instructions of the outdoor unit, refer to the relevant manuals.

Contents

	Page
Dimensions and weight.....	2
Nominal data	2
Operating limits	2
Minimum clearances	3
Material supplied	3
General information	4
Warnings: avoid	5
Installation	6/7
Refrigerant connections	8
Check	9
Electrical connection	10/12
The General Information For Multi or T-kit model	13
Operating test	14
Address switch	14
Guide for the owner	14
Accessories	14

Models AC-HP (R410A)	Power supply
42PHQ007N 42PHQ009N 42PHQ012N 42PHQ014N 42PHQ018N 42PHQ024N	230V ~ 50Hz

AC Cooling only
HP Heat pump

42PHQ---N

Dimensions and weight

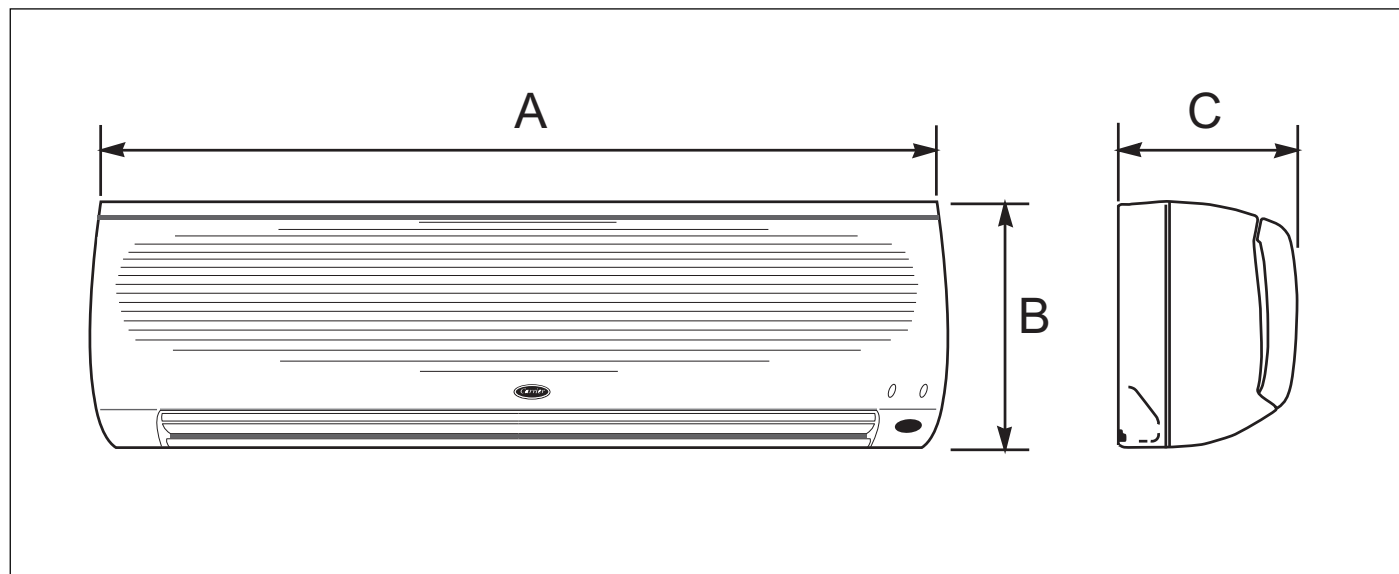

Mod.		42PHQ007N	42PHQ009 - 012 - 014N	42PHQ018 - 024N
A	mm	790	790	1080
B	mm	260	260	295
C	mm	186	186	185
	kg	8	8.6	14

ELECTRIC POWER INPUT		
Cooling only unit		
	Cooling W	Heating W
42PHQ007N	32	-
42PHQ009N	43	-
42PHQ012N	43	-
42PHQ014N	43	-
42PHQ018N	53	-
42PHQ024N	53	-
Heat pump		
42PHQ007N	32	32
42PHQ009N	43	43
42PHQ012N	43	43
42PHQ014N	43	43
42PHQ018N	53	53
42PHQ024N	53	53

Table I: Nominal data

- Unit is not suitable for operation in laundry premises.
- For sizing of power supply wires and delay type fuses, refer to the outdoor unit installation instructions.

Table II: Operating limits

Cooling/Heating	Refer to outdoor unit installation manual.	
Mains power supply	Nominal single-phase voltage Operating voltage limits	230V ~ 50Hz min. 198V – max. 264V

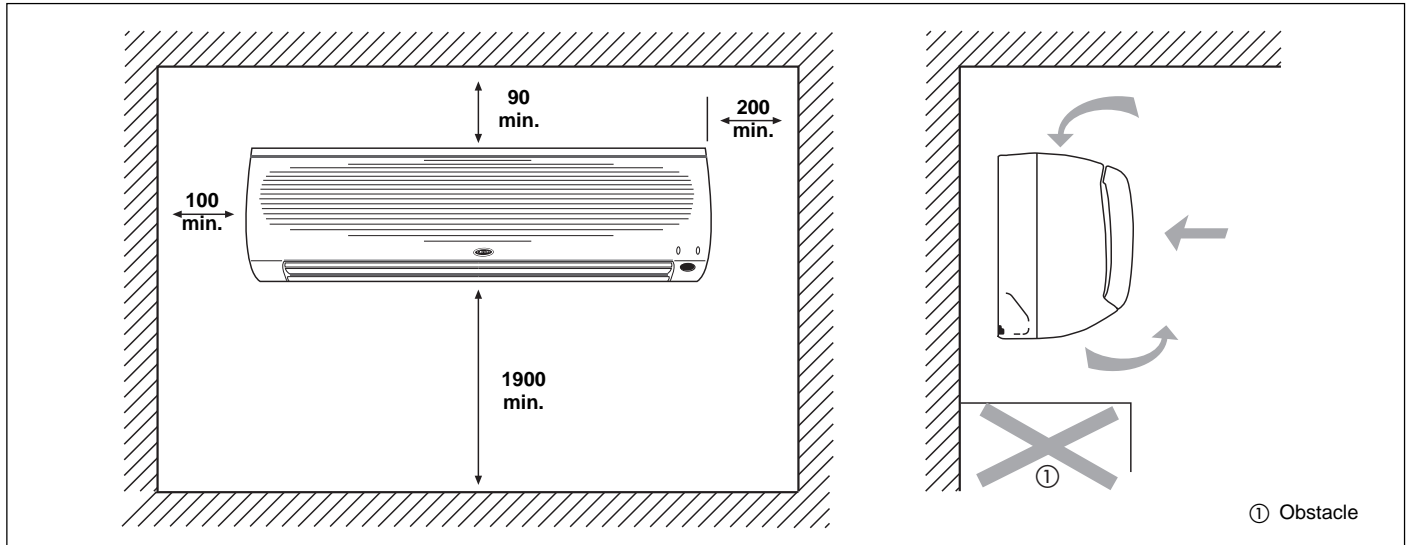
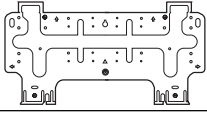

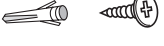
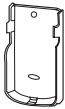

Table III: Material supplied

The following installation accessories are supplied with unit. Use them as required.

Name and shape	Q.ty	Use
Wall hanging bracket 	1	For indoor unit installation
Screws 4xL10 	2	For fixing unit and hanging bracket
Screws anchors and screws 6xL25 Washers Ø 12 	4 + 4 + 4	For wall hanging bracket installation
Screws anchors and screws 6xL20 	2 + 2	For cordless remote control mounting bracket installation
Cordless remote control mounting bracket 	1	For cordless remote control installation

The following field-supplied items are required to complete the installation.

Name	Specification
Connection pipe	42PHQ007, 009N: Ø (3/8") 9,52 mm (Gas) / Ø (1/4") 6,35 mm (Liquid) 42PHQ012, 014, 018, 024N: Ø (1/2") 12,70 mm (Gas) / Ø (1/4") 6,35 mm (Liquid)
Wall sleeve	
Wall cap	
Finishing tape	PVC film
Fastening tape	
Pipe insulation	
Drain hose	I.D. 16-17 mm
Sealer putty	
- Power supply cable	H07RN-F or higher
- Electrical connecting cable between indoor and outdoor unit	Cable type: A07 RN-F, synthetic rubber insulation with Neoprene coating according to EN (IEC) 60335-2-40 standards.

42PHQ---N

General information

Unit installation

Read this instruction manual thoroughly before starting the installation.

- This unit complies with low-voltage (EEC/73/23) and electromagnetic compatibility (EEC/89/336) directives.
- The installation must be carried out by a qualified installer.
- Follow all current national safety code requirements. In particular ensure that a properly sized and connected ground wire is in place.
- Check that voltage and frequency of the mains power supply are those required for the unit to be installed; the available power must be adequate to operate any other possible appliances connected to the same line. Also ensure that national safety code requirements have been followed for the mains supply circuit.
- Connect indoor and outdoor units with field-supplied copper pipes by means of flare connections. Use insulated seamless refrigeration grade pipe only, (Cu DHP type according to ISO1337), degreased and deoxidized, suitable for operating pressures of at least 4200 kPa and for burst pressure of at least 20700 kPa. Under no circumstances must sanitary type copper pipe be used.
- Where necessary, use field-supplied 16 -17 mm I.D. PVC pipe of appropriate length and with the correct thermal insulation for the condensate drain extension.
- After the installation thoroughly test system operation and explain all system functions to the owner.
- Leave this manual with the owner for consultation during future periodic maintenance.
- Use this unit only for factory approved applications: **the unit cannot be used in laundry or steam pressing premises.**

IMPORTANT:

During the unit installation make first refrigerant connections and then electrical connections. If unit is uninstalled first disconnect electrical cables, then refrigerant connections.

WARNING:

Disconnect the mains power supply switch before servicing the system or handling any internal parts of the unit.

- Do not open the remote control to avoid possible damage. In case of malfunctioning contact a qualified service engineer.
- Control batteries contain polluting elements. When exhausted they must be disposed of according to local requirements.
- This installation manual describes the installation procedures of the indoor unit of a residential split system consisting of two units manufactured by Carrier. Consult the factory or a qualified system engineer prior to connecting this unit to any other manufacturer's outdoor unit. Coupling units which have different control systems, may cause irreversible damage and void the warranty protection. The manufacturer declines any liability for system malfunction resulting from unapproved coupling.
- The manufacturer declines any liability for damage resulting from modifications or errors in the electrical or refrigerant connections.

- Failure to observe the installation instructions or use of the unit under conditions other than those indicated in Table II (operating limits), will immediately void the unit warranty.
- Failure to observe electric safety codes may cause a fire hazard in case of short circuits.
- Inspect equipment for damage due to improper transportation or handling; file an immediate claim with the shipping company. Do not install or use damaged units.
- In case of any malfunctioning turn the unit off, disconnect the mains power supply and contact a qualified service engineer.
- Maintenance of the refrigerant circuit must only be carried out by qualified personnel.
- **All of the manufacturing and packaging materials used for your new appliance are compatible with the environment and can be recycled.**
- Dispose of the packaging material in accordance with local requirements.
- This equipment contains refrigerant that must be disposed of in the proper manner. When disposing of the unit after its operational life, remove it carefully. The unit must then be delivered to an appropriate disposal centre or to the original equipment dealer for proper environmentally compatible disposal.

Choosing the installation site

Positions to avoid:

- Exposed to direct sun.
- Too close to heat sources.
- On humid walls or positions with water hazard, e.g. laundry premises.
- Where curtains or furniture may obstruct free air circulation.

Recommendations:

- Install the unit at more than 1,9 mt from the floor.
- Choose an area free from obstructions which may cause irregular air distribution and/or return.
- Check that the wall surface is flat enough to allow easy and safe installation. The wall structure should be strong enough to carry the unit weight and avoid deformation, rupture or vibration during operation.
- Consider using an area where installation is easy.
- Choose a position that allows for the clearances required (see drawing).
- Look for a position in the room which assures the best possible air distribution.
- Install unit in a position where condensate can easily be piped to an appropriate drain.

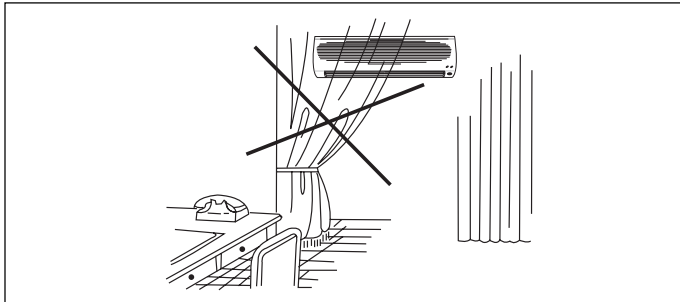

Any obstruction of the unit air outlet or return.

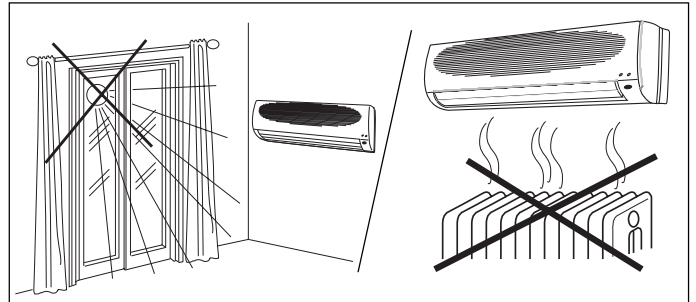

Exposure to direct sunshine, when unit is operating in cooling mode; always use shutters or shades.
Positions too close to heating sources which may damage the unit.

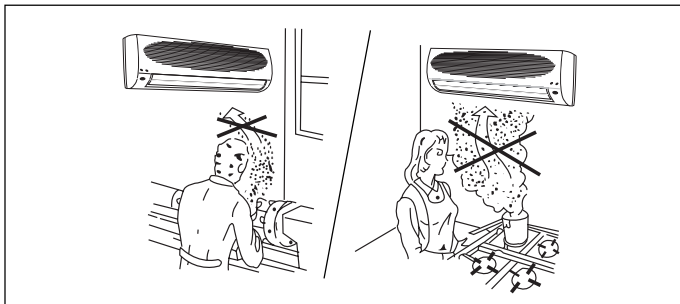

Exposure to oil vapours.

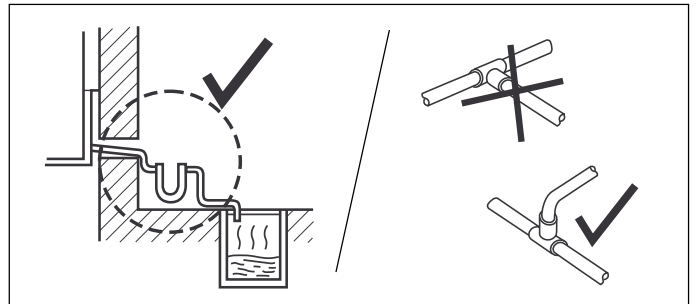

Connecting condensate piping to sewage system drain without appropriate trap. Trap height must be calculated according to the unit discharge head in order to allow sufficient and continuous water evacuation.

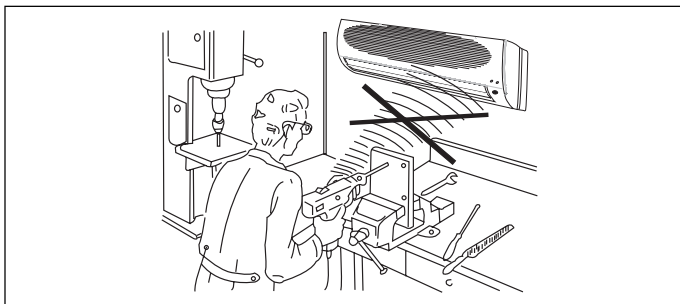

Installation in areas with high-frequency waves.

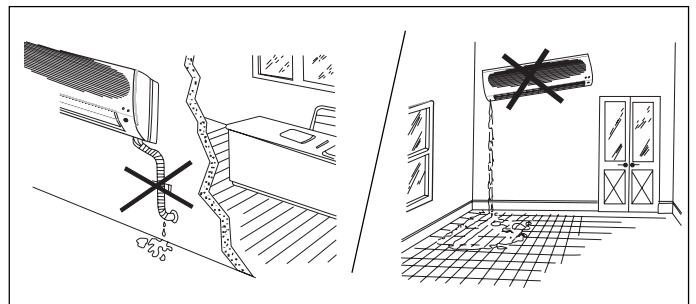

Only partial insulation of the piping.
Installation not correctly leveled which will cause condensate dripping.

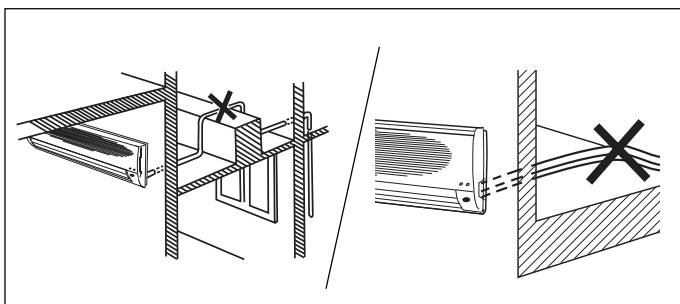

Any rise in the condensate drain piping.
Horizontal condensate drain piping with less than 2% slope.

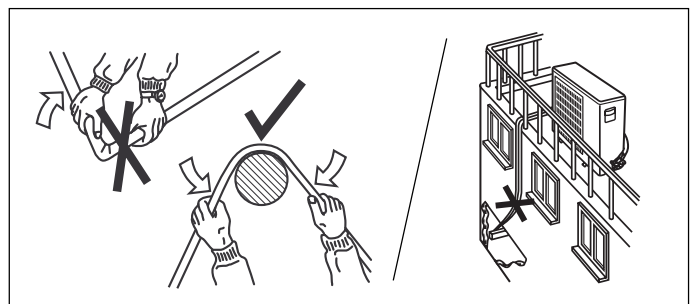

Flattening or kinking the refrigerant pipes or condensate pipes.
Excessive height difference between outdoor and indoor units (see installation manual of outdoor unit).

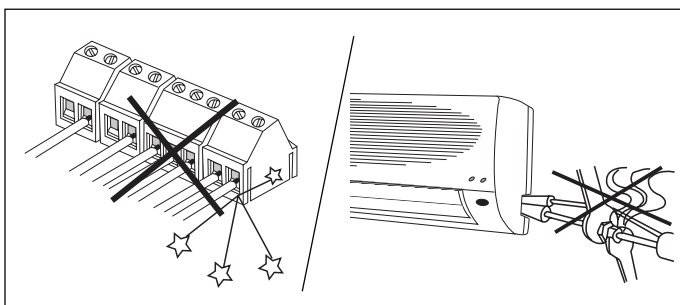

Slack on electrical connections.
Disconnecting refrigerant connections after installation: this will cause refrigerant leaks.

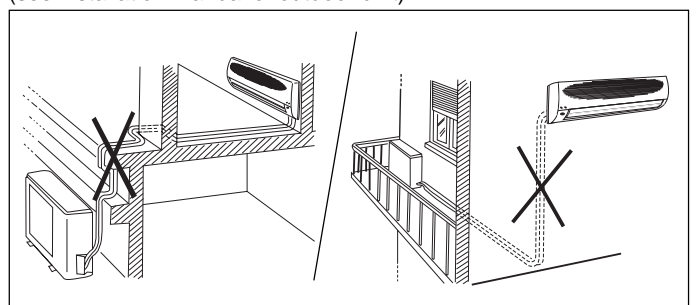

Unnecessary turns and bends in interconnecting tubing.
Excessive interconnecting tube length (see installation manual of outdoor unit).

42PHQ---N

Installation

- The piping can be connected in the four ways indicated by ①, ②, ③ and ④.
- When the piping is connected to points ①, ② or ④, remove the knock-out either at the side or at the bottom of the unit.

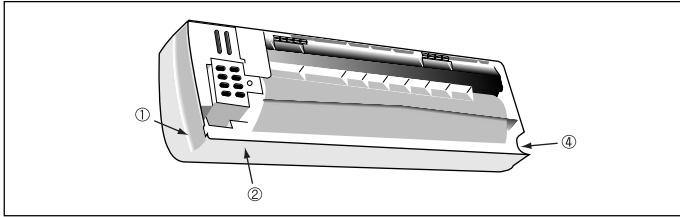
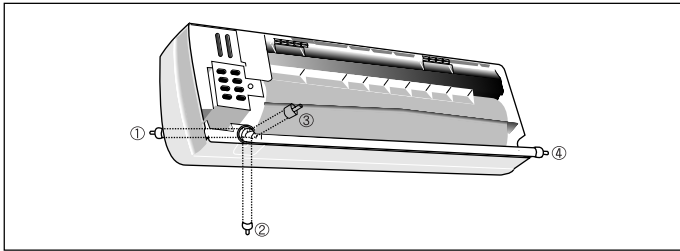

IMPORTANT NOTE:
This unit has no refrigerant expansion device.

Installing the wall hanging bracket

- Install the wall hanging bracket so that it is level. Use a plumb line if necessary.
- Be sure to leave the clearance spaces. (Refer to page 3).
- If the wall hanging bracket is not level, water may drip onto the floor.
- Install the wall hanging bracket with a fixing that is strong enough to withstand the weight of the unit.

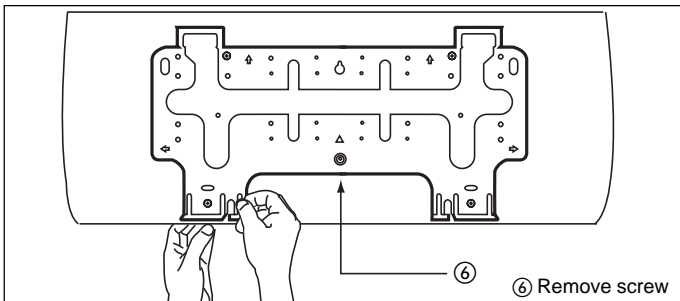
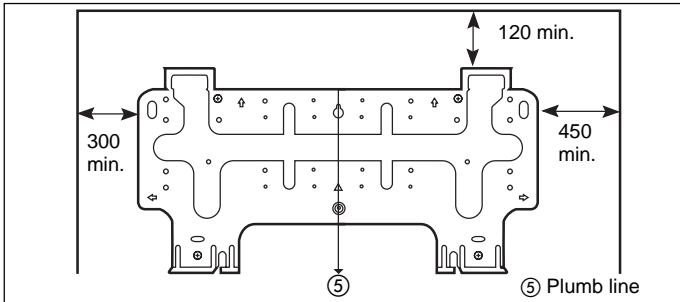

- Before installing the wall hanging bracket, remove it from the unit by pushing at the indicated parts at the bottom of the body.
- Fasten the wall hanging bracket to the wall with 4 or more screw anchors through the holes near the outer edge of the bracket.
- Install the wall hanging bracket so that there is no gap between the bracket and the wall.
- Check that the wall hanging bracket does not move. This can cause noise during operation.
- If the unit is removed from the wall hanging bracket after installing it onto the wall, remove it by pushing up the indicated MARKS (▲) at the bottom of the body. (Refer to page 7).

Marking the wall penetration for the connection piping

Rear piping

- It is best for the piping to go through the wall behind the unit, so that the unit hides the pipes.
- For this method of installation, make a 65 mm diameter hole in the wall at point A.

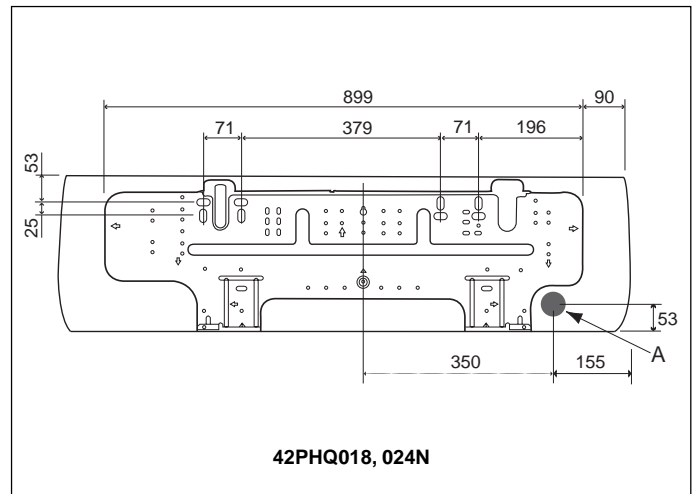
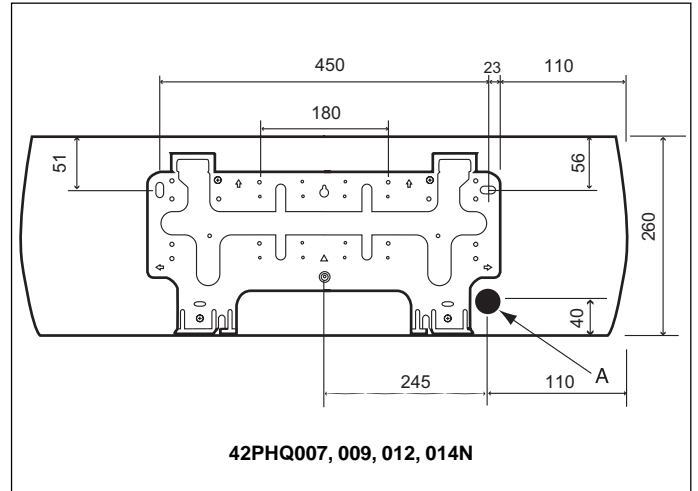

- Drill a 65 mm diameter hole at a slope so that the outside end is lower (5 - 10 mm) than the inside end. This will ensure good drainage.
- Cut the wall sleeve to match the wall thickness and pass the pipe through the hole.

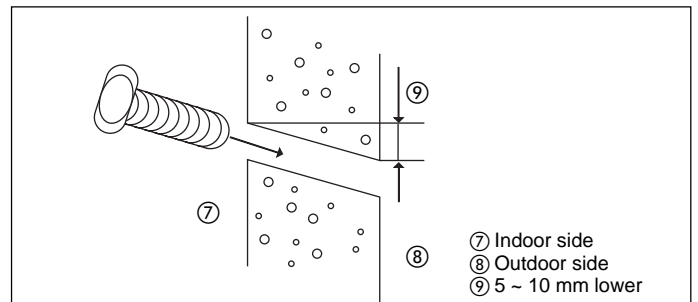

Side or bottom piping

- Remove the knock-out in the unit and pass the pipes through the wall.
- The pipe should slope downward and away from the unit to ensure good drainage.

Routing the drain hose and refrigerant piping

- Tie together the refrigerant pipe, the drain hose, and the electrical connection cord.
- Route the refrigerant piping in the required direction, and bind the drain hose and the electrical connection cord together with fastening tape. The drain hose should be at the bottom.

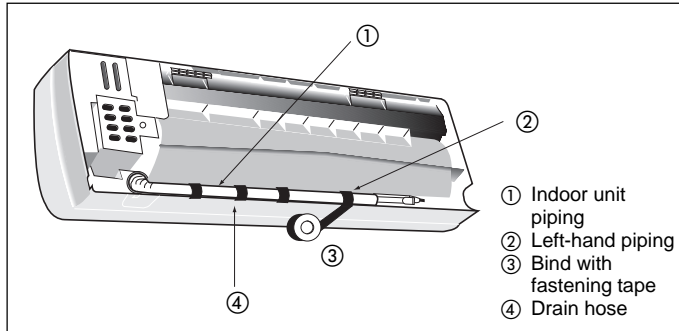

- For left-hand piping, fit the pipes and the wiring into the recess at the back of the unit.

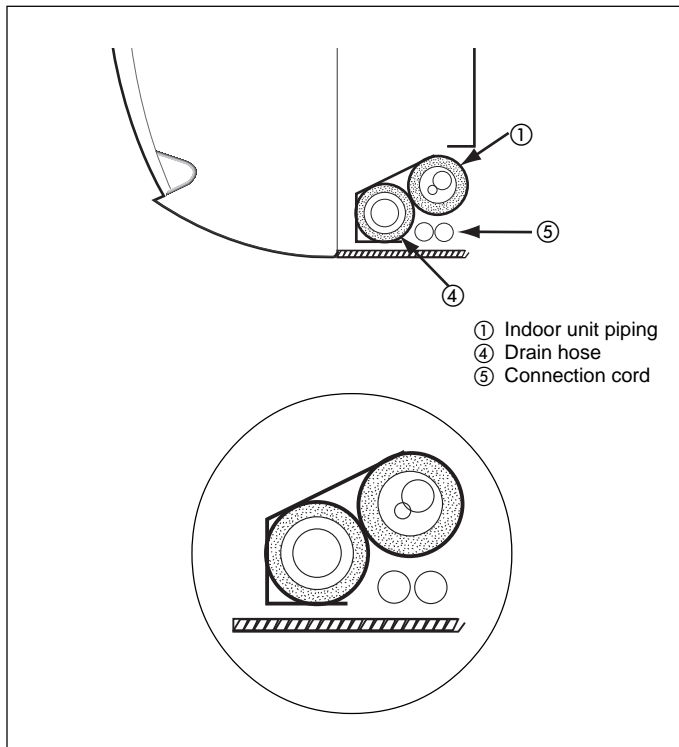

⑥ Wall hanging bracket
⑦ Hook
⑧ Hole

[mm]

	A	B
42PHQ007, 009, 012, 014N	300	220
42PHQ018, 024N	270	195

NOTE:

- Do not crush or kink the indoor piping. Avoid sharp bends with a bend radius of less than 100 mm.
- Do not bend the same part of the pipe too often.
- Do not remove the flare nut from the indoor unit pipe until the piping is connected.
- The recommended bending of the drain hose is shown.

Installing the indoor unit body to the wall hanging bracket

- Pass the pipes through the wall sleeve and then hook the indoor unit body on top of the wall hanging bracket.
- For left-hand piping, hang the unit on top of the wall hanging bracket and incline the unit using a tool such as a screwdriver set between the middle area of the body and bottom right of the wall hanging bracket. Connecting the pipe can be done more easily if the unit is inclined.
- Fix the bottom part of the unit to the wall hanging bracket, by pushing it carefully until the two bracket hooks fit into the marked places at the base of the unit (a click will be heard).

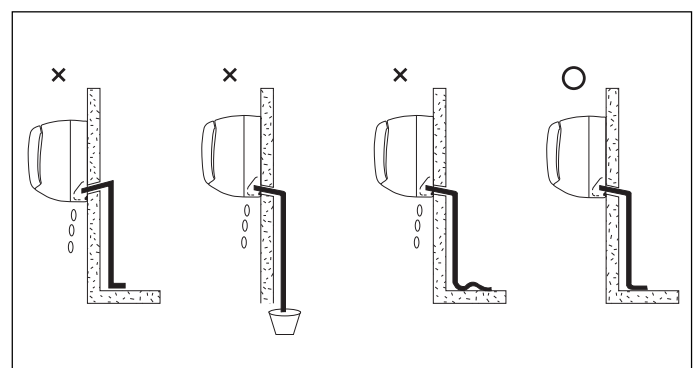

42PHQ---N

Refrigerant connections

Refer to the outdoor unit installation manual for tube sizing, and limitations (slope, length, number of bends allowed, refrigerant charge, etc.).

Model	Tubing diameter			
	Gas (Suction)		Liquid (Discharge)	
	mm	(inches)	mm	(inches)
42PHQ007N 42PHQ009N	9,52	(3/8")	6,35	(1/4")
42PHQ012N 42PHQ014N 42PHQ018N 42PHQ024N	12,70	(1/2")	6,35	(1/4")

For refrigerant tubes use seamless, insulated refrigeration grade tube, (Cu DHP type according to ISO1337), degreased and deoxidized, suitable for operating pressures of at least 4200 kPa and for burst pressure of at least 20700 kPa. Under no circumstances must sanitary type copper pipe be used.

Flaring the end of the tubing

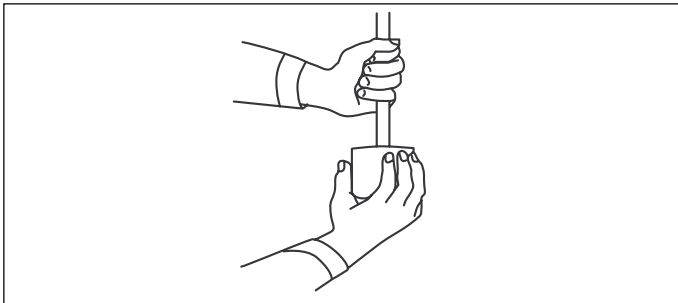

Remove protective caps from the copper tube ends. Position tube end downward, cut the tube to the required length and remove the burrs with a reamer.

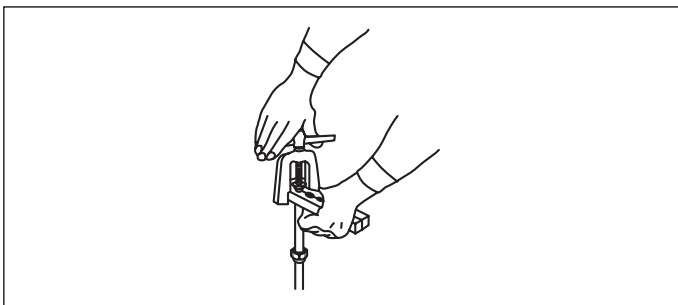

Remove flare nuts from the unit connections and place them on the tube end. Flare the tube with the flaring tool.

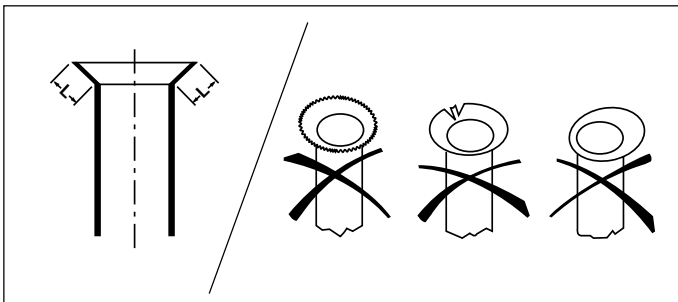

Flare end must not have any burrs or imperfections. The length of the flared walls must be uniform.

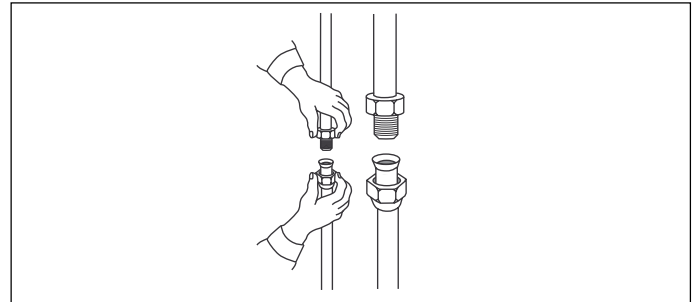

Lubricate the tube end and thread of the flare fitting with anti-freeze oil. Finger-tighten the fitting several turns, then tighten it fully with two wrenches by applying the tightening torque indicated in the table.

Connection to the unit

Insufficient tightening torque will cause gas leaks. Overtightening the fittings will damage the tube flaring and cause gas leaks.

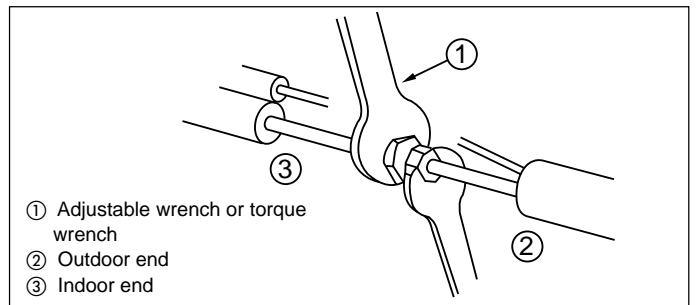

- ① Adjustable wrench or torque wrench
- ② Outdoor end
- ③ Indoor end

Tubing diameter mm (inches)	Torque Nm
6.35 (1/4")	18
9.52 (3/8")	42
12.70 (1/2")	55
15.87 (5/8")	65

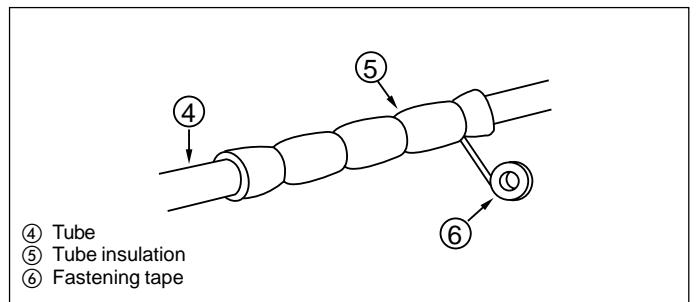

Once all connections have been completed, check for leaks by applying soapy water to them. Finally wrap connections with anti-condensate insulation and tighten with tape, without exerting great pressure on the insulation. Repair and cover any possible cracks in the insulation. Connection pipes and electric cables between indoor and outdoor units must be fixed to the wall with appropriate conduits.

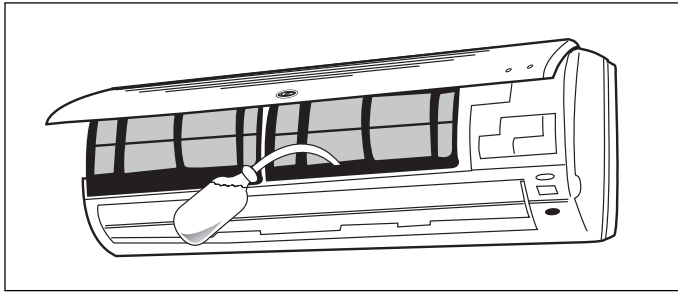

- Next, check the unit drain system by pouring some water into the unit drain pan and ensuring that it flows freely through the drain hose and that there is no leakage from any other part.

Use of additional screws

After installation, if there is a significant gap between the unit and wall, it can be adjusted by securing the body to the wall hanging bracket using 2 screws. Screw holes can be only seen after removing the frame grille.

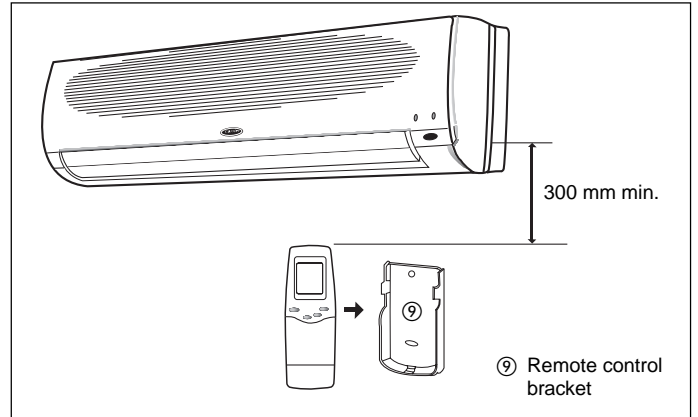

Installing the remote control bracket

- Fix the bracket onto the wall using double sided adhesive tape or 2 screws.
- Install the batteries in the remote control and position it in the bracket.

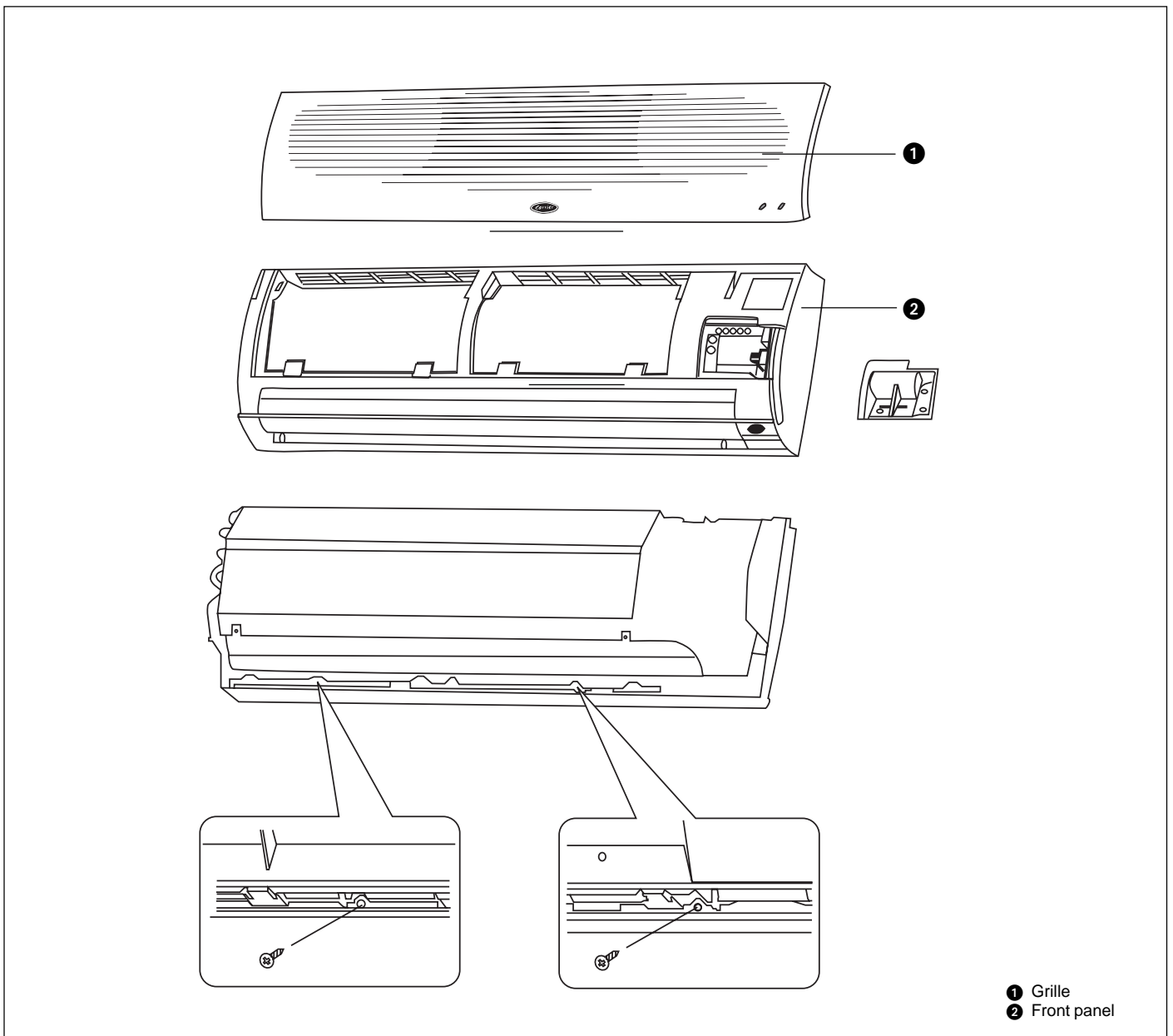

- ① Grille
- ② Front panel

42PHQ---N

Electrical connection

IMPORTANT:

- **Make refrigerant connections before electrical connections.**
When disconnecting, disconnect electrical connections before refrigerant connections.

- **Make ground connection prior to any other electrical connections.**

- Make electrical connections between units prior to proceeding to mains supply unit connection.

- Before proceeding with the connection to the mains supply locate live **L** and neutral **N**, then make connections as shown in the wiring diagram.

- Ensure that mains supply connection is made through a switch that disconnects all poles, with contact gap of a least 3 mm.

- The indoor - outdoor unit connecting wires must be A07 RN-F type (or higher), with synthetic rubber insulation with Neoprene coating, according to EN 60335-2-40.

- The mains supply connecting cable must be H07 RN-F type (or higher), with synthetic rubber insulation with neoprene coating, according to EN 60335-2-40.

- Ground connection between indoor and outdoor units is made via the refrigerant pipes.

Notes:

All field electrical connections are the responsibility of the installer.

Indoor unit wiring

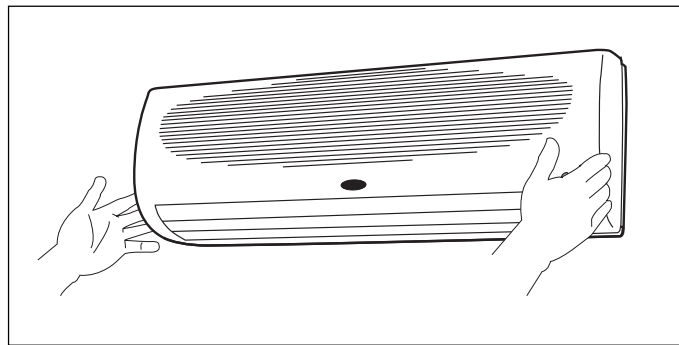

- Lift the front panel up to the top of the unit; in this way the front panel will be separated from the unit.

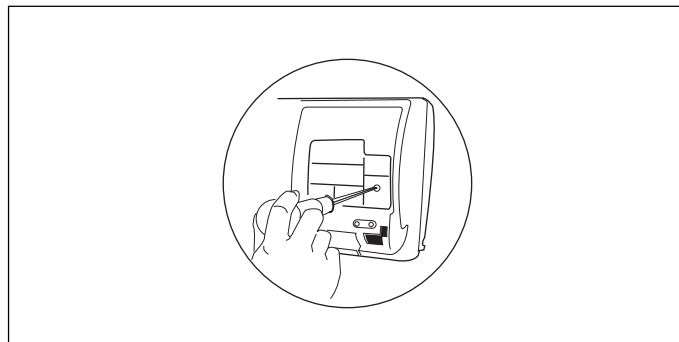

- Remove the plastic cover of the terminal board.
- Make the electrical connections to the terminal board as per the wiring diagram.
- When the electrical connections are completed, refit the terminal board cover and fix the cables with the special cable holders.
- Fix the front panel to the latch of the frame grille.

Cooling only (42PHQ007, 009, 012, 014N)

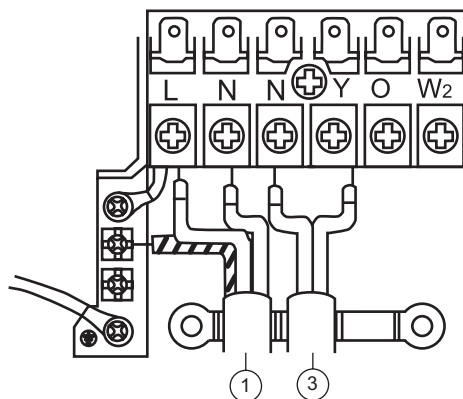

NB:
See outdoor unit
installation manual.

Model	Minimum connection wire size (mm ²)			Minimum connection wire size between indoor and outdoor (mm ²)			
	GND	L	N	N	Y	O	W2
42PHQ 007N, 009N	1,5	1,5	1,5	1,5	1,5	-	-
42PHQ 012N, 014N	2,5	2,5	2,5	2,5	2,5	-	-

42PHQ---N

Electrical connection

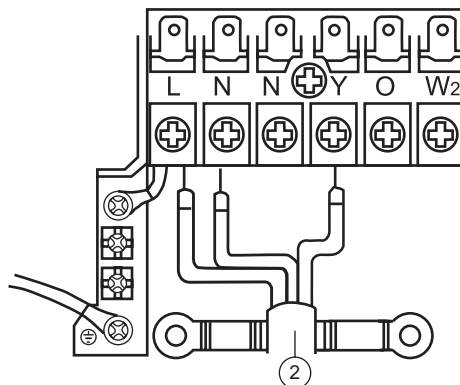

NB:
See outdoor unit
installation manual.

Model	GND	Minimum connection wire size between indoor and outdoor (mm ²)					
		L	N	N	Y	O	W2
42PHQ 007N, 009N	-	1,5	1,5	-	1,5	-	-
42PHQ 012N, 014N	-	2,5	2,5	-	2,5	-	-

Cooling only (42PHQ018, 024N)

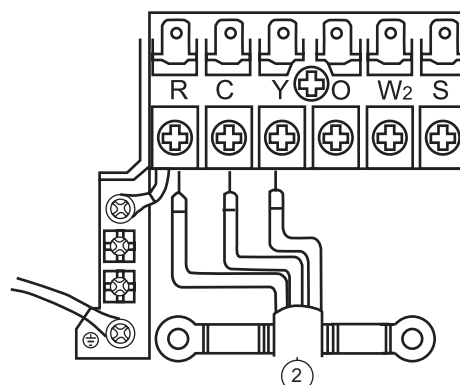

NB:
See outdoor unit
installation manual.

Model	GND	Minimum connection wire size between indoor and outdoor (mm ²)					
		R	C	Y	O	W2	S
42PHQ 018N, 024N	-	1	1	1	-	-	-

Terminal box legend

- Earth
- L** Live power supply
- N** Neutral power supply
- N** Neutral connection indoor/outdoor unit
- R** Live connection indoor/outdoor unit
- C** Neutral connection indoor/outdoor unit
- Y** Compressor interlocking contact
- O** Reversing valve control
- W2** Outdoor fan signal.
- S** Defrost end signal

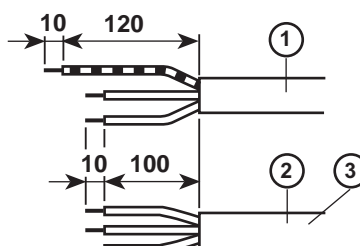

- ① Power supply cable (H07 RN-F)
- ② Interconnection cable (A07 RN-F)
- ③ Interconnection cable (H07 RN-F)

42PHQ---N

Electrical connection

Heat pump (42PHQ007, 009, 012, 014N)

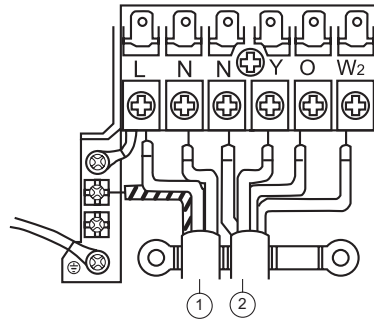

NB:
See outdoor unit
installation manual.

Model	Minimum connection wire size (mm ²)			Minimum connection wire size between indoor and outdoor (mm ²)			
	GND	L	N	N	Y	O	W2
42PHQ 007N, 009N	1,5	1,5	1,5	1,5	1,5	1,5	1,5
42PHQ 012N, 014N	2,5	,25	2,5	2,5	2,5	2,5	2,5

Heat pump (42PHQ007, 009, 012, 014N)

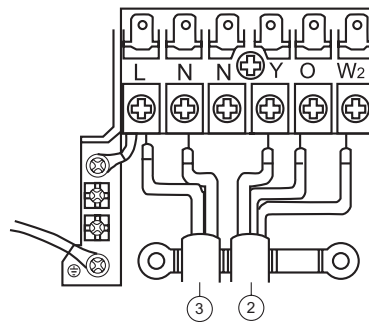

NB:
See outdoor unit
installation manual.

Model	GND	Minimum connection wire size between indoor and outdoor (mm ²)					
		L	N	N	Y	O	W2
42PHQ 007N, 009N	-	1,5	1,5	-	1,5	1,5	1,5
42PHQ 012N, 014N	-	2,5	2,5	-	2,5	2,5	2,5

Heat pump (42PHQ018, 024N)

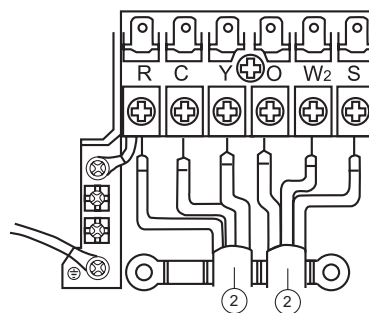

NB:
See outdoor unit
installation manual.

Model	GND	Minimum connection wire size between indoor and outdoor (mm ²)					
		R	C	Y	O	W2	S
42PHQ 018N, 024N	-	1	1	1	1	1	1

Terminal box legend

- Earth
- L Live power supply
- N Neutral power supply
- N Neutral connection indoor/outdoor unit
- R Live connection indoor/outdoor unit
- C Neutral connection indoor/outdoor unit
- Y Compressor interlocking contact
- O Reversing valve control
- W2 Outdoor fan signal.
- S Defrost end signal

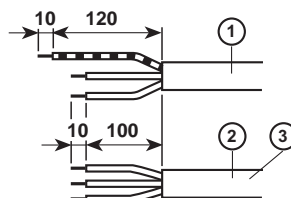

- ① Power supply cable (H07 RN-F)
- ② Interconnection cable (A07 RN-F)
- ③ Interconnection cable (H07 RN-F)

The configuration setting by remote controller

• Entering Configuration Mode

- Press the **"MODE"**(2) button together with the **"FLAP"**(3) button for 7 continuous seconds while remote is in OFF mode.

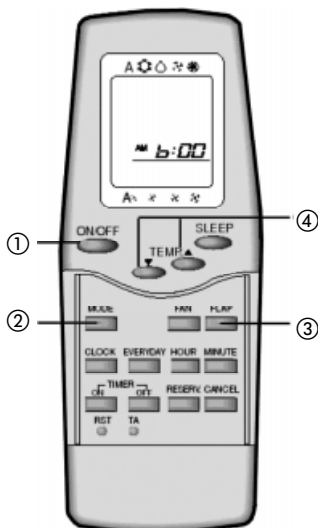

LCD will display the following message:

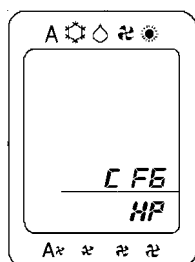

In case of first use or after battery change, default values will be displayed. [CFG/HP]
Once user has changed configuration, the new stored values will be displayed.

• Configuration Procedure

- **"MODE"** (2) Button - Selects the different configuration items: AC – HP and Mono – T-Kit – Multi application (please refer to Example).
- **"▲"** and **"▼"** (4) Buttons – Increase or decrease the displayed value.
Once a value is changed, it flashes until the **"FLAP"** (3) button is pressed.
- **"FLAP"** (3) Button - Transmits a configuration message for the parameter that is displayed.
If user wants to configure more than one parameter, the **"FLAP"** (3) button must be pressed step by step until each parameter is being displayed.
- **"I/O"** (1) Button - To exit Configuration Mode, and return the LCD display back to its previous operating condition (OFF mode).

If there is no key-in during 30 continuous seconds, the remote will exit automatically the Configuration mode.
The parameter is set back to its latest transmitted value.

Example :

1) Step: "Enter configuration mode"

- Press **MODE** and **FLAP** buttons together for 7 seconds.

2) Step: "Unit configuration"

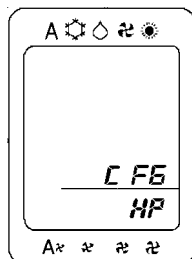

- Display : "CFG"
- Default Value : "HP"
- Available Value :
HP – Heat Pump
AC – Cool Only

3) Step: "Transmit and Go to next step"

- Press **FLAP** button and then **MODE** button.

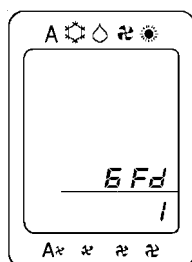

4) Step: "Application selection"

- Display : "GFd"
- Default Value : "1"
- Available Value :
1–238 : Mono (1x1)
239 : T-Kit
240 : Multi

5) Step: "Transmit and Exit configuration mode"

- Press **FLAP** button and then **I/O** button.

6) Step: "System reset"

- After changing configuration by remote, **TURN OFF AND THEN ON ELECTRIC POWER SUPPLY** to the system to make configuration effective.

The Operating Test for Multi or T-kit model

This procedure is used to check the operation after unit installation.

Press the **EMER.** button continuously for 5-10 seconds.
The unit will now be in **TEST** mode.

Press the **EMER.** button once more after checking, to return to normal operation.

If there is any input signal (remote control signal or **EMER.** button press) during test operation, the **TEST** mode will return to normal operation.

The setting conditions of the **TEST** operation for Multi or T-kit model are as follows.

- Operation LED : **ON**
- Timer LED : Blink ON for 0.5 seconds and OFF for 0.5 seconds four(for T-kit model) and three times(for Multi model)
- Operating mode :
Cool mode for 3 minutes, firstly and then **Heat mode** for 2 minutes and **Cool mode** until test mode is exited
- Fan speed : **High**
- Timer mode : **Disabled**
- Discharge air direction : **SWING**

42PHQ---N

Operating test and address switch - Guide for the owner and accessories

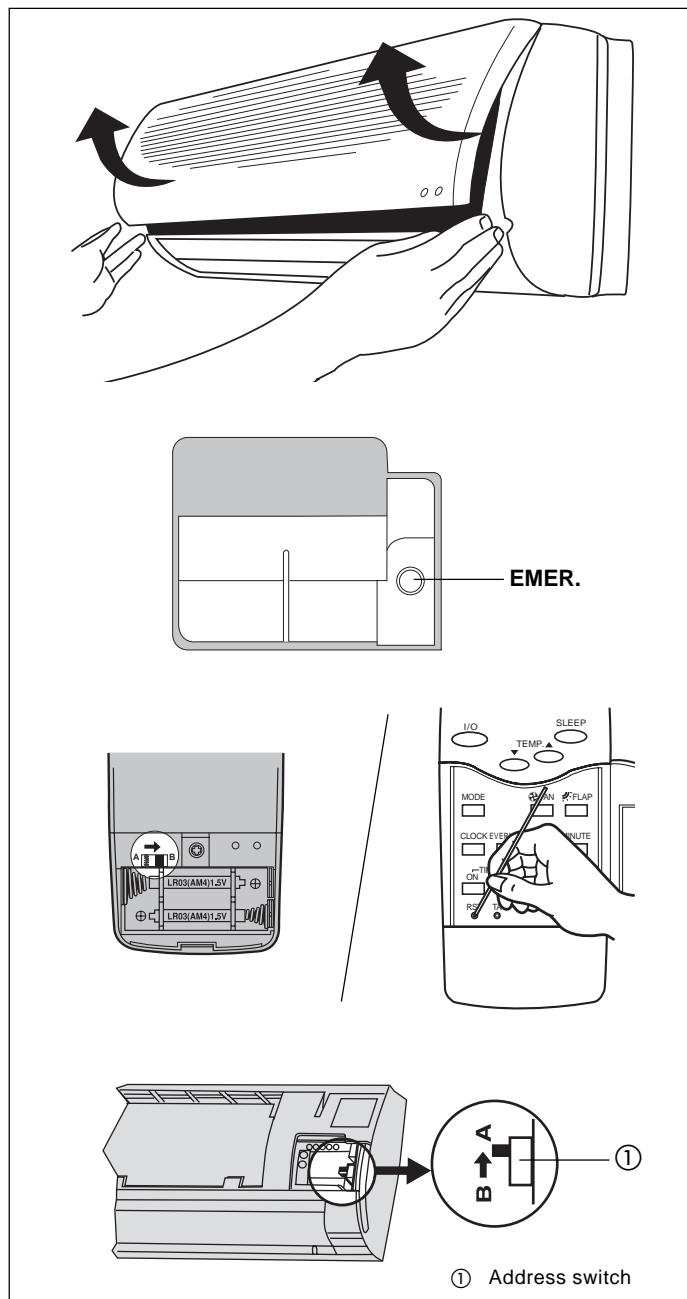

Operating test

This procedure is used to check the operation after unit installation.

- Press the EMER. button continuously for 5~10 seconds. The unit will now be in Test Mode.
- Press the EMER. button once more after checking, to activate the remote control. If there is any input signal (remote control signal or EMER. button press) during test operation, the TEST mode will change to the input signal mode.
- The setting conditions of the test operation are as follows:
 - Operating mode: COOL
 - Fan speed: HIGH
 - Timer mode: Disabled
 - Discharge air direction: SWING

NOTE:

- Indoor fan speed will be "HIGH" in Test operation.
- The swing motor will operate when the indoor fan is operated.
- Operate the unit in accordance with the Owner's Manual and check the following:
 - a. Indoor unit.
 - Do all switches operate normally?
 - Does each light come on normally?
 - Do the horizontal louvres operate normally?
 - Is the drain correct?
 - b. Outdoor unit.
 - Is there any abnormal noise or vibration during operation?
 - Is there any gas leakage?

Address switch

If you are installing two indoor units in the same room, it is necessary for you to assign each unit its own address so each can be operated by its own remote control. One address switch is on the back of remote control, and the other is in the PCB side.

The address switch is set to A when you purchase the unit.

- **Remote control**
 - Remove the lid of the battery case.
 - Assign the address switch of one remote control to B.
 - Press the **RST** button with a sharp object.
- **Indoor unit**
 - Turn off the unit and pull out the power plug.
 - Remove the front panel and terminal block cover.
 - Assign the address switch of one indoor unit to B.

Guide for the owner

Guide for the owner

When installation and tests are completed explain the Operation and Maintenance Manual to the owner, with particular attention to the main operating modes of the air conditioner, such as:

- Turning the unit on and off.

- Functions of the remote control.
- Removal and cleaning of the air filters.

Leave the two installation manuals for the indoor and outdoor units with the owner for future use during maintenance operations or for any other needs.

Table IV : Accessories

Description	Part number	42PHQ---N					
		007	009	012	014	018	024
Active carbon filter and electrostatic filter	42PHW9100	●	●	●	●		
	42PHW9101					●	●
Photocatalytic filter and electrostatic filter	42PHW9102	●	●	●	●		
	42PHW9103					●	●



Via R. Sanzio, 9 - 20058 Villasanta (MI) Italy - Tel. 039/3636.1

The manufacturer reserves the right to change any product specifications without notice.