



CONTINUOUS FLOW ICEMAKER

Installation and Service Manual

500-Series
700-Series
1000-Series
2000-Series

Distributed By:
Commercial Refrigeration Service, Inc.
WWW.WorldRestaurantSupply.COM
toll free (866) Ice Maker
(623) 869-8881

Part No. 638085278
August 1999
Revision C

THIS DOCUMENT CONTAINS IMPORTANT INFORMATION

This Manual must be read and understood before installing or operating this equipment

TABLE OF CONTENTS

	Page
SAFETY INFORMATION	1
RECOGNIZE SAFETY INFORMATION	1
UNDERSTAND SIGNAL WORDS	1
FOLLOW SAFETY INSTRUCTIONS	1
GENERAL DESCRIPTION	3
SPECIFICATION CHART	3
INSTALLATION	7
A. REMOVE ICEMAKER FROM CARTON	7
B. CABINET REMOVAL	7
C. PREPARATION OF INSTALLATION SITE	7
D. WATER INLET HOOK UP	7
E. DRAIN CONNECTION	7
F. ELECTRICAL SUPPLY	8
G. AUGER ENGAGEMENT	8
H. BIN CONTROL	8
INITIAL START UP, CHECKS AND ADJUSTMENT INSTRUCTIONS	8
GUIDE TO SERVICE	13
ICEMAKER CLEANING AND SANITIZING PROCEDURES	13
MAINTENANCE	13
MONTHLY	13
QUARTERLY	13
SEMI-ANNUALLY	14
WATER LEVEL CONTROL	15
HOW WATER LEVEL CONTROL WORKS	15
PURPOSE	15
TO REPLACE WATER LEVEL CONTROL	15
TO REPLACE WATER LEVEL SAFETY SWITCH	15
REFRIGERATION SYSTEM	16
NOTE: THERMOSTATIC EXPANSION VALVE NO ADJUSTMENT	16
±10 LBS. DISCHARGE PRESSURE	16
WATER TEMPERATURE	16
AIR TEMPERATURE	16
REFRIGERATION SYSTEM ADJUSTMENTS	16
EXPANSION VALVE	16
ADJUSTMENT AND TROUBLESHOOTING	16
CONDENSER MODULATING VALVE	17
CONDENSER MODULATING VALVE REMOVAL	17
BIN CONTROL	18
GEARMOTOR	18
MOTOR CHECK	19
START RELAY	19
TO REPLACE GEARMOTOR ASSEMBLY	20
INSTALLATION AND SHAFT SEAL REPLACEMENT	20

TABLE OF CONTENTS (cont'd)

	Page
AUGER AND EXTRUDING HEAD REMOVAL	21
INSTALLATION AND SHAFT SEAL REPLACEMENT 700 & 1000	21
UPPER NUT AND BEARING ASSEMBLY	21
TO REPLACE BEARING	22
ELECTRICAL CHECKOUT	22
OVERLOAD CHECK	22
COMPRESSOR CHECK	22
CAPACITOR CHECK	23
SAFETY CONTROLS	23
TROUBLESHOOTING	27
THE COMPRESSOR WILL NOT RUN	27
THE COMPRESSOR STARTS BUT TRIPS REPEATEDLY ON THE OVERLOAD PROTECTOR	27
THE COMPRESSOR RUNS BUT WILL NOT REFRIGERATE	27
REFRIGERATION AND ICEMAKER ASSEMBLY MODEL 500 SERIES	32
REFRIGERATION AND ICEMAKER ASSEMBLY MODEL 700 SERIES	34
REFRIGERATION AND ICEMAKER ASSEMBLY MODEL 1000 SERIES	36

LIST OF FIGURES

FIGURE 1. SERIES 500 & 700 DIMENSION DRAWING (SHIPPING WT. 160 LBS. APPROX).	4
FIGURE 2. SERIES 1000 DIMENSION DRAWING (SHIPPING WT. 210 LBS. APPROX).	4
FIGURE 3. SERIES WCC2001-A AND WCF2201-A DIMENSION DRAWINGS	5
FIGURE 4. BIN CONTROL	8
FIGURE 5. ICEMAKER FLOAT ASSEMBLY	9
FIGURE 6. SCHEMATIC AND WIRING DIAGRAM WCC2001-A AND WCF2201-A	9
FIGURE 7. SCHEMATIC AND WIRING DIAGRAM WCC500-A, WCC500-W, WCC700-A, WCC700-W, WCF510-A, WCF510-W, WCF710-A, & WCF710-W	10
FIGURE 8. SCHEMATIC AND WIRING DIAGRAM WCC701-A, WCC701-W, WCC1001-A, WCC1001-W WCF711-A, WCF711-W, WCF1101-A, & WCF1101-W	10
FIGURE 9. SCHEMATIC AND WIRING DIAGRAM WCF1101R, WCC1001R, WCF1102R, & WCC1102R	11
FIGURE 10. SCHEMATIC AND WIRING DIAGRAM WCC502, WCC702, WCC1002, WCF512, WCF712, & WCF1102	11
FIGURE 11. SCHEMATIC AND WIRING DIAGRAM WCC2001-R AND WCF2201-R	12
FIGURE 12. UPPER NUT AND BEARING ASSEMBLY	14
FIGURE 13. EXPANSION VALVE	17
FIGURE 14. ADJUSTMENT SCREW	17
FIGURE 15. BIN CONTROL SWITCH	18
FIGURE 16. GEARMOTOR ASSEMBLY	20
FIGURE 17. SHAFT SEAL 500	20
FIGURE 18. AUGER AND EXTRUDING HEAD REMOVAL	20

TABLE OF CONTENTS (cont'd)

	Page
FIGURE 19. SHAFT SEAL 700 & 1000	21
FIGURE 20. OVERLOAD CHECK	22
FIGURE 21. COMPRESSOR CHECK	22
FIGURE 22. GEAR MOTOR OVERLOAD	23
FIGURE 23. REFRIGERATION AND ICEMAKER ASSEMBLY MODEL 2000 SERIES EXPLODED VIEW AND PARTS LIST	30
FIGURE 24. REFRIGERATION AND ICEMAKER ASSEMBLY MODEL 500 SERIES	31
FIGURE 25. REFRIGERATION AND ICEMAKER ASSEMBLY MODEL 700 SERIES	33
FIGURE 26. REFRIGERATION AND ICEMAKER ASSEMBLY MODEL 1000 SERIES	35
FIGURE 27. WATER LEVEL CONTROL ASSEMBLY MODEL WCC500/700/1000 SERIES EXPLODED VIEW AND PARTS LIST	37
FIGURE 28. FRONT END ASSEMBLY MODEL 500 SERIES EXPLODED VIEW AND PARTS LIST	38
FIGURE 29. FRONT END ASSEMBLY MODEL 700 SERIES EXPLODED VIEW AND PARTS LIST	39
FIGURE 30. FRONT END ASSEMBLY MODEL 1000 & 2000 SERIES EXPLODED VIEW AND PARTS LIST	40
FIGURE 31. ELECTRICAL BOX ASSEMBLY MODEL 500 AND 700 SERIES ..	41
FIGURE 32. ELECTRICAL ASSEMBLY MODEL 1000 AND 2000 SERIES	42
WARRANTY	43

SAFETY INFORMATION

Recognize Safety Information

This is the safety-alert symbol. When you see this symbol on our machine or in this manual, be alert to the potential of personal injury.

Follow recommended precautions and safe operating practices.



Understand Signal Words

A signal word - *DANGER*, *WARNING*, *CAUTION* is used with the safety-alert symbol. *DANGER* identifies the most serious hazards.

Safety signs with signal word *DANGER* or *WARNING* are typically near specific hazards.

General precautions are listed on *CAUTION* safety signs. *CAUTION* also calls attention to safety messages in this manual.



Follow Safety Instructions

Carefully read all safety messages in this manual and on your machine safety signs. Keep safety signs in good condition. Replace missing or damaged safety signs. Learn how to operate the machine and how to use the controls properly. Do not let anyone operate the machine without instructions. Keep your machine in proper working condition. Unauthorized modifications to the machine may impair function and/or safety and affect the machine life.



CAUTION: Very high discharges pressure is present in system. Quick disconnects on your gages will minimize danger and loss of refrigerant.



CAUTION: Unit requires separate electrical line. See instruction manual for proper fuse size.



WARNING: There must be adequate clearance around icemaker. Allow minimum 6" air intake and 4" air exhaust for air exhaust and panel removal.

NOTE: Unit must be installed per local plumbing and electrical codes. See Installation manual for unit requirements. Failure to do so may cause damage to unit, which would void unit warranty.

NOTE: Using any parts other than genuine factory manufactured parts relieves the manufacturer of all liability.

NOTE: Manufacturer reserves the right to change specifications at any time.

THIS PAGE LEFT BLANK INTENTIONALLY

GENERAL DESCRIPTION

This section gives the Unit description, theory of operation, and design data for continuous flow icemaker series 500, 700, 1000, and 2000.

IMPORTANT: *To the user of this manual* – This manual is a guide for installing, operating, and maintaining this equipment. Refer to the Table of Contents for page location for detailed information pertaining to questions that arise during installation, operation, service, or maintenance of this equipment.

SPECIFICATION CHART

Models	Condensing Unit	VAC	HZ	PH	Wire	Comp. RLA	Fan Amps	GRMTR Amps	Refrigerant		Circuit Fuse
									Oz.	Type	
WCC500-A	Air Cooled	115	60	1	2	10.1	1.1	2	24	R404A	20
WCC500-W	Water Cooled	115	60	1	2	10.1	N/A	2	11	R404A	20
WCC502-A	Air Cooled	220/240	50	1	2	5.3	0.5	1.6	24	R404A	20
WCC502-W	Water Cooled	220/240	50	1	2	5.3	N/A	1.6	11	R404A	20
WCF510-A	Air Cooled	115	60	1	2	10.1	1.1	2	24	R404A	20
WCF510-W	Water Cooled	115	60	1	2	10.1	N/A	2	11	R404A	20
WCF512-A	Air Cooled	220/240	50	1	2	5.3	0.5	1.6	24	R404A	20
WCF512-W	Water Cooled	220/240	50	1	2	5.3	N/A	1.6	11	R404A	20
WCC700-A	Air Cooled	115	60	1	2	12	1.6	2	24	R404A	20
WCC700-W	Water Cooled	115	60	1	2	12	N/A	2	13	R404A	20
WCC701-A	Air Cooled	208/230	60	1	2	7.7	1.6	2	24	R404A	20
WCC701-W	Water Cooled	208/230	60	1	2	7.7	N/A	2	13	R404A	20
WCC702-A	Air Cooled	220/240	50	1	2	8.2	0.5	1.6	24	R404A	20
WCC702-W	Water Cooled	220/240	50	1	2	8.2	N/A	1.6	13	R404A	20
WCF710-A	Air Cooled	115	60	1	2	12	1.6	2	24	R404A	20
WCF710-W	Water Cooled	115	60	1	2	12	N/A	2	13	R404A	20
WCC711-A	Air Cooled	208/230	60	1	2	7.7	1.6	2	24	R404A	20
WCC711-W	Water Cooled	208/230	60	1	2	7.7	N/A	2	13	R404A	20
WCF712-A	Air Cooled	220/240	50	1	2	8.2	0.5	1.6	24	R404A	20
WCF712-W	Water Cooled	220/240	50	1	2	8.2	N/A	1.6	13	R404A	20
WCC1001-A	Air Cooled	208/230	60	1	2	7.5	0.85	2	26	R404A	20
WCC1001-W	Water Cooled	208/230	60	1	2	7.5	N/A	2	17	R404A	20
WCC1002-A	Air Cooled	220/240	50	1	2	8.9	0.85	2	26	R404A	20
WCF1101-A	Air Cooled	208/230	60	1	2	7.5	0.85	2	26	R404A	20
WCF1101-W	Water Cooled	208/230	60	1	2	7.5	N/A	2	17	R404A	20
WCF1102-A	Air Cooled	220/240	50	1	2	8.9	0.85	2	26	R404A	20
WCC1001-R	Remote	220/240	60	1	2	7.5	N/A	2	120	R404A	15
WCF1101-R	Remote	208/230	60	1	2	7.5	N/A	2	120	R404A	15
WCC2001-A	Air-Cooled	208/230	60	1	2	12.9	.85	(2) 2	46	R404A	25
WCC2001-R	Remote	220/240	60	1	2	12.9	1.7	(2) 2	220	R404A	25
WCC2001-W	Water Cooled	208/230	60	1	2	12.9	N/A	(2) 2	28	R404A	25
WCC2002-A	Air Cooled	220/240	50	1	2	11.4	.85	(2) 2	46	R404A	25
WCF2201-A	Air-Cooled	208/230	60	1	2	12.9	.85	(2) 2	46	R404A	25
WCF2201-W	Water Cooled	208/230	60	1	2	12.9	N/A	(2) 2	28	R404A	25
WCF2202-A	Air Cooled	220/240	50	1	2	11.4	.85	(2) 2	46	R404A	25

NOTE: For units not listed in above chart, refer to nameplate or contact factory service.

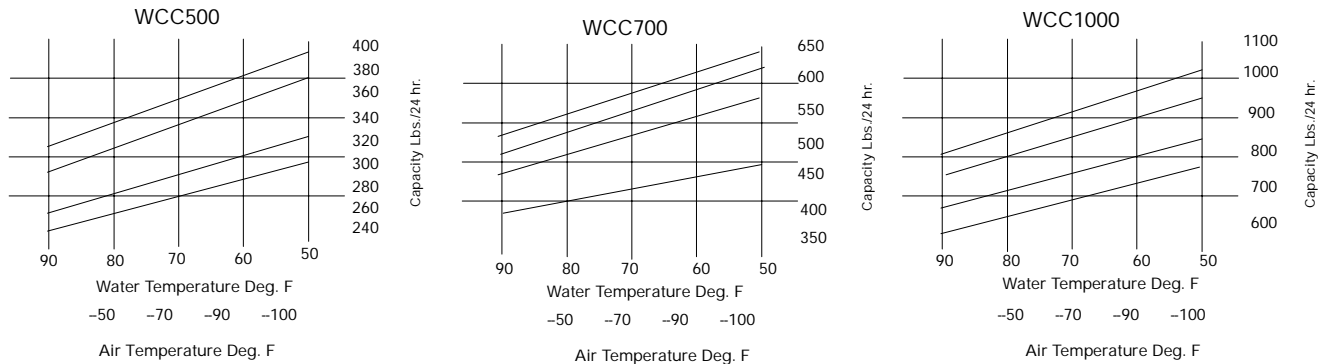

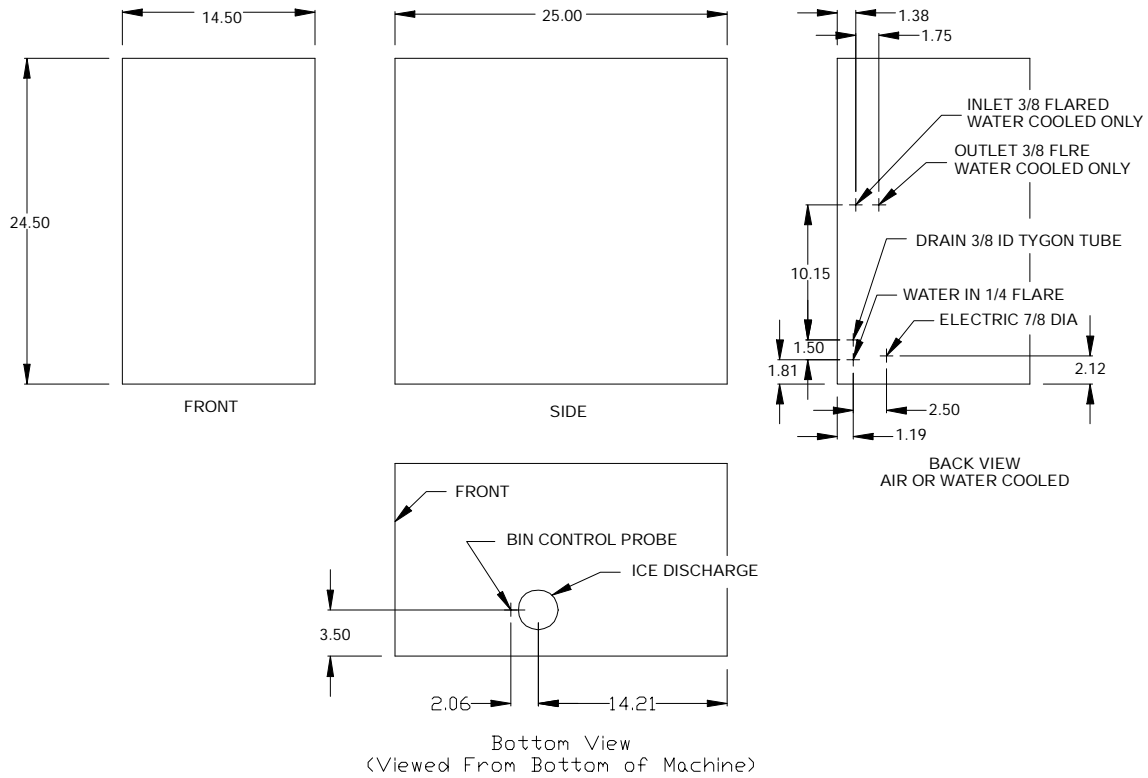

FIGURE 1. SERIES 500 & 700 DIMENSION DRAWING (Shipping Wt. 160 lbs. Approx).

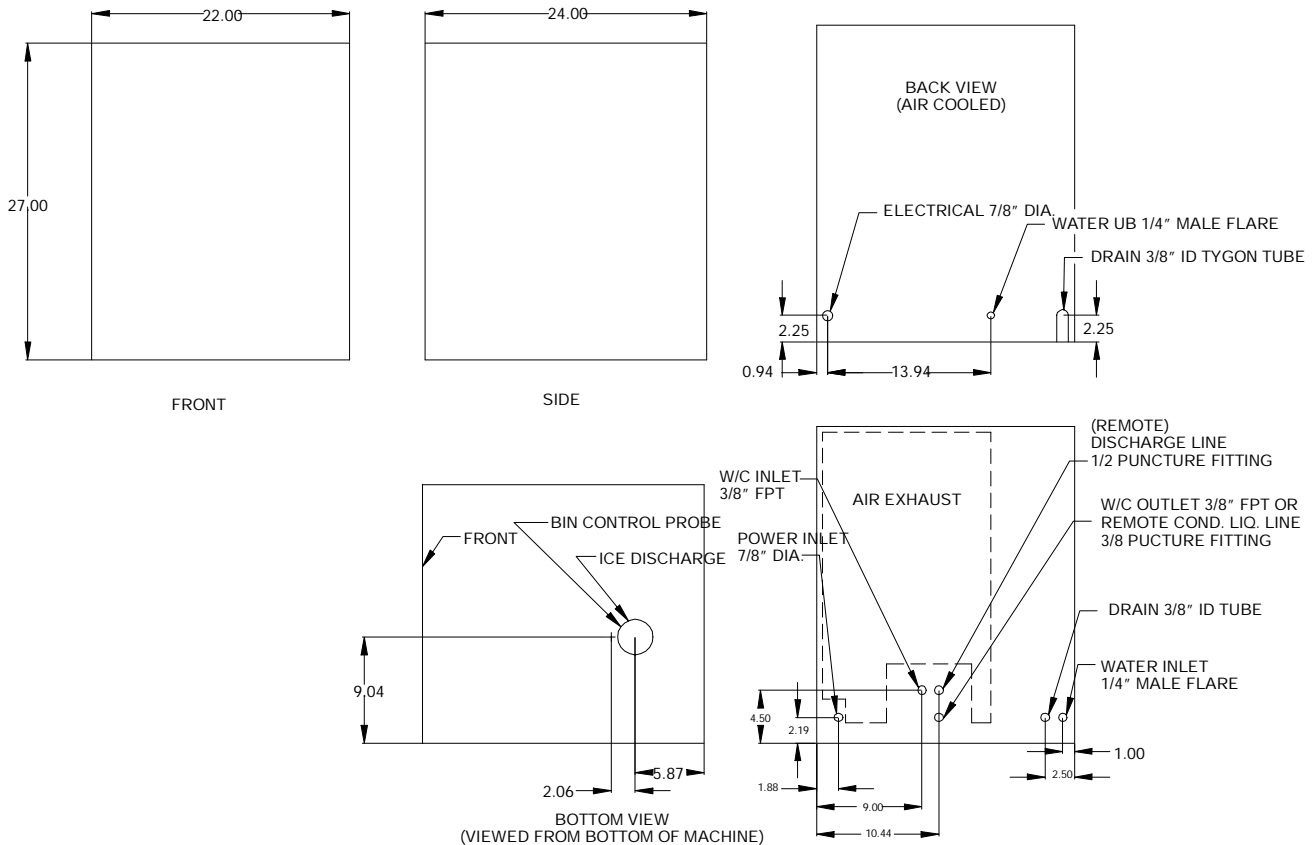

FIGURE 2. SERIES 1000 DIMENSION DRAWING (Shipping Wt. 210 lbs. Approx).

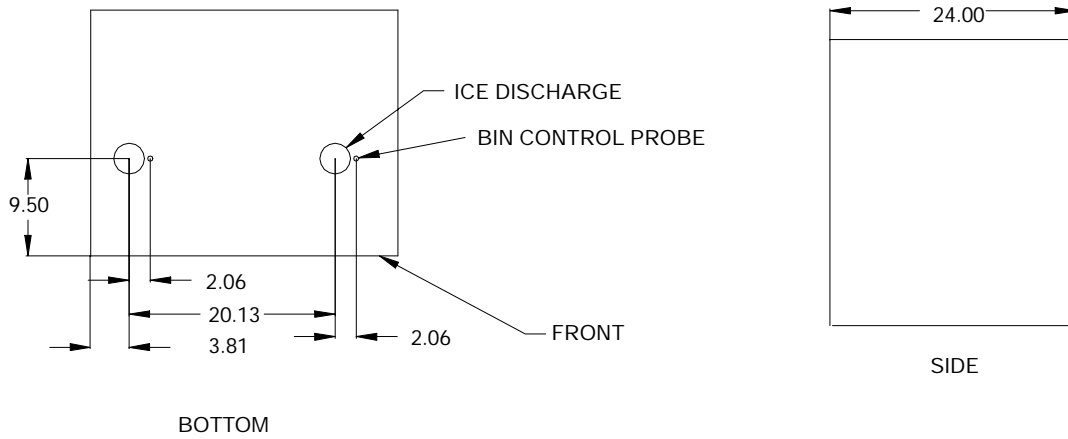
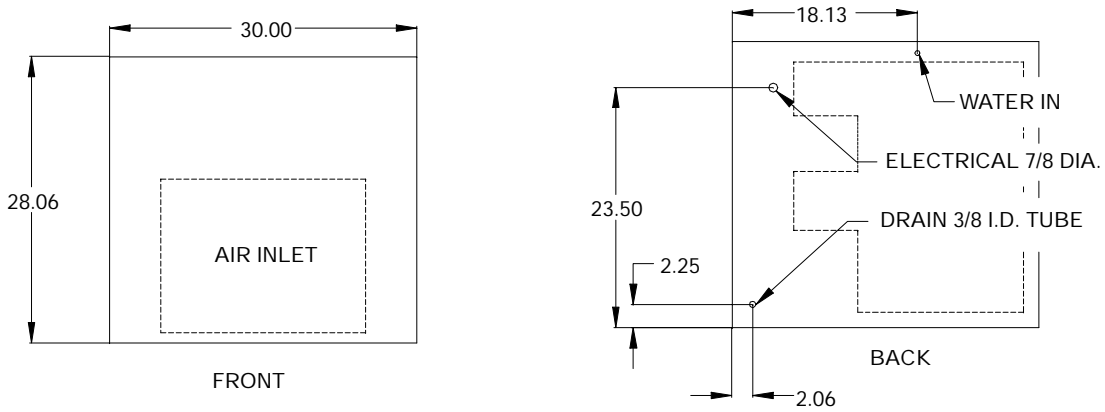

FIGURE 3. SERIES WCC2001-A AND WCF2201-A DIMENSION DRAWINGS

THIS PAGE LEFT BLANK INTENTIONALLY

INSTALLATION

This section covers unpacking and inspection, selecting location, installing unit, preparing for operation, and operation.

A. REMOVE ICEMAKER FROM CARTON

1. Keep unit in the upright position, remove carton and pallet from unit and inspect unit for damage. *Upon inspection of unit, if any damage is found, file a claim with carrier immediately.*
2. Locate startup card either on outside of container or on plastic liner. Fill in proper information and send one copy to factory, and other copy to distributor. Postage is prepaid.

B. CABINET REMOVAL

1. Front Panel– Remove 4 screws and pull forward.
2. Top Panel– Remove screws and lift upward. 4 screws 500/700, 6 screws 1000.
3. Side Panel– Remove 4 screws and pull forward.
4. Back Panel– Should not be removed.

C. PREPARATION OF INSTALLATION SITE

1. The refrigeration system on air cooled units requires airflow, so a well ventilated area should be chosen. A minimum of 6 inches must be maintained, free of any obstructions, for air intake. A minimum of 4 inches clearance is required for air exhaust.
2. The unit can be installed either on an ice storage bin or ice dispenser using the proper adapter kits. (Refer to sales literature for information.) The install is kit provided with each icemaker and adapter kits will supply everything to locate unit correctly. In all cases the icemaker should be sealed all around the base with an NSF listed sealant. (63804815B)

D. WATER INLET HOOK UP

1. Water Inlet– fitting is a 1/4 SAE male flare located at the rear of the unit. Connect water supply with a 1/4 SAE flare nut and 1/4" copper or flexible tubing or larger.
2. Water Pressure– Unless otherwise specified, the unit is designed to operate on water pressures between 10 P.S.I. and 90 P.S.I. (NOTE: for pressures above 90 P.S.I. a regulator must be installed.)
3. Condenser Inlet Connections– Use a separate 3/8" copper line or larger water line. Connect to 3/8 FPT fitting on water modulating valve.
4. Filter/Conditioners are recommended on supply lines to icemakers. Never run the water supply to water cooled condenser through filter/conditioner, it uses up the cartridge unnecessarily and a saturated cartridge can starve the icemaker causing premature component damage. Separate water supplies are recommended.

NOTE: Unit must be installed per local plumbing code BOCA.

E. DRAIN CONNECTION

1. Overflow Line– is a 3/8" I.D. flexible tube located at the rear of the unit. Extend this line to proper drain.
2. Condenser Outlet– is a 3/8" FPT located on the rear panel.

NOTE: Unit must be installed per local plumbing code. BOCA.

F. ELECTRICAL SUPPLY

1. Power Access– is provided with a 7/8" dia. knockout hole in the rear panel. Route incoming power in conduit, through rear panel to icemaker electrical control box. Make connections to wires provided in the control box and ground lug/screw.
2. Fused Line– should be checked and sized according to electrical rating shown on unit nameplate.

G. AUGER ENGAGEMENT

Be certain that auger is fully engaged to lower drive and extruding head is fully engaged into evaporator.

H. BIN CONTROL

1. Remove tape holding control to white ice chute and also remove control bracket mounting screw located in base of unit behind electrical box. (Screw will be used later to fasten bin control bracket to base of unit).
2. Slide control and bracket down chute to base of unit. *very carefully* guide control and bracket through 1/2" hole in front of ice chute. Use CAUTION to be sure control goes into bin, not between base of unit and bin top.
3. Check location of bin control, it should be directly under ice chute at a 45° angle. With control in place use mounting screw that was removed in step 1 to secure bracket to base. See Figure 4

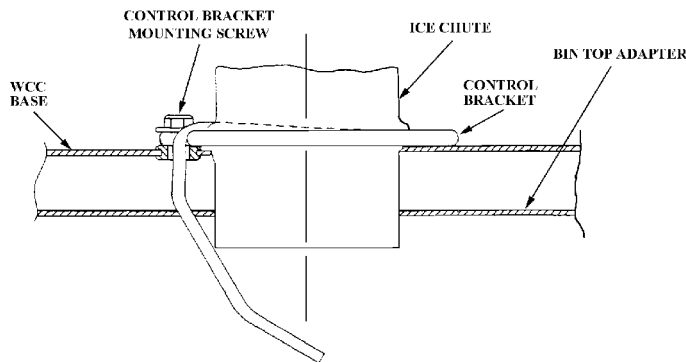

FIGURE 4. BIN CONTROL

INITIAL START UP, CHECKS AND ADJUSTMENT INSTRUCTIONS

NOTE: Do not start unit before completing installation steps on pages 7 and 9.

Turn on water supply (if unit is water cooled turn water on to condenser also) turn on main power switch (located on top of electrical box), and make the following system checks:

NOTE: If unit will not start be sure water reservoir is full. Low water safety control must be properly adjusted to start and shut down unit. If water level drops below bottom of reservoir, unit must shut down. Adjustment is made by moving magnet up or down.

Water Level– If necessary adjust float by bending float arm up or down as needed, push float assembly down until unit stops running. Release float and unit will restart. Keep water in reservoir at level line while unit is in operation. See Figure 5

Low Water Safety Control– Adjust magnet by bending magnet arm as needed to shut unit down if water level drops below bottom of reservoir.

Bin Control– Place ice around probe, unit should shut down in one minute. Remove ice from around probe, unit should start in two minutes.

NOTE: For altitudes over 1000 feet above sea level, adjust range screw (behind end cover). Half turn max. raises setting 4_F approx.

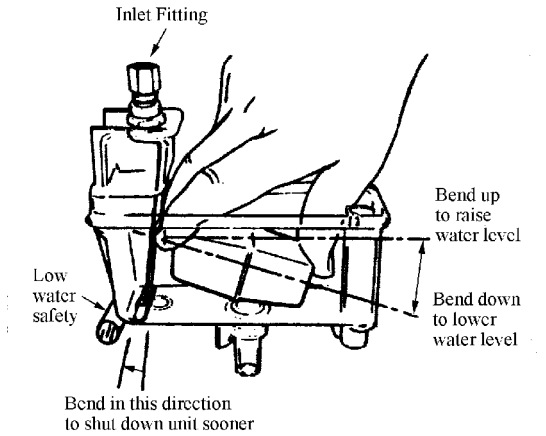

FIGURE 5. ICEMAKER FLOAT ASSEMBLY

Water modulating valve (water cooled units only)– Opening point of condenser water modulating valve should be set to maintain proper operating pressure in the refrigeration system high side. (see chart on page 16). Closing point of valve should be set low enough to close valve during compressor stand by periods. To raise, turn counterclockwise, to lower turn clockwise.

NOTE: If any of these checks or adjustments cannot be achieved, refer to Troubleshooting Section of this manual or call for factory assistance at 1-800-Service.

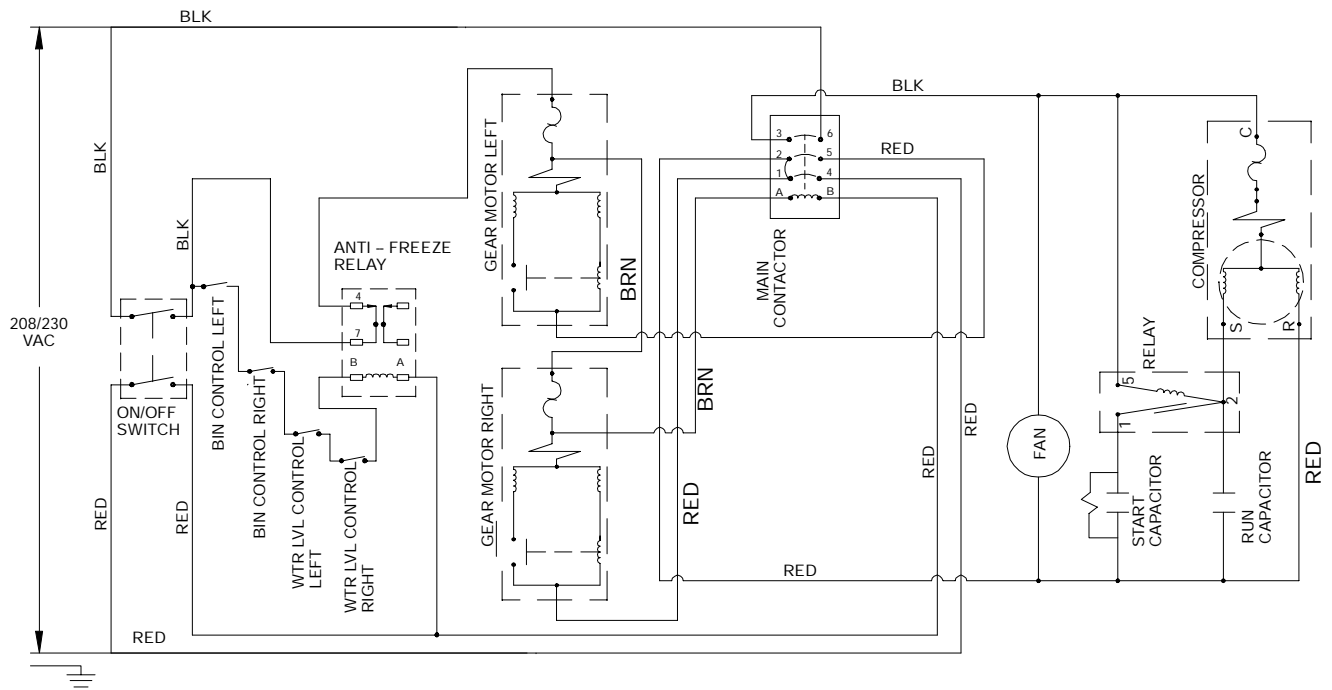

FIGURE 6. SCHEMATIC AND WIRING DIAGRAM WCC2001-A AND WCF2201-A

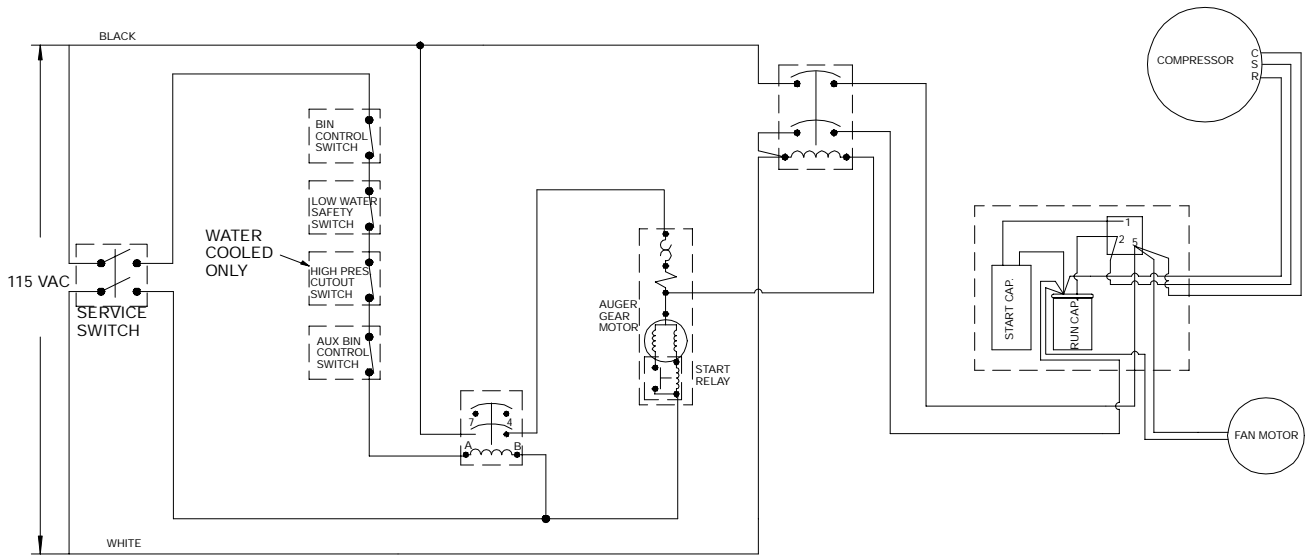

FIGURE 7. SCHEMATIC AND WIRING DIAGRAM WCC500-A, WCC500-W, WCC700-A, WCC700-W, WCF510-A, WCF510-W, WCF710-A, & WCF710-W

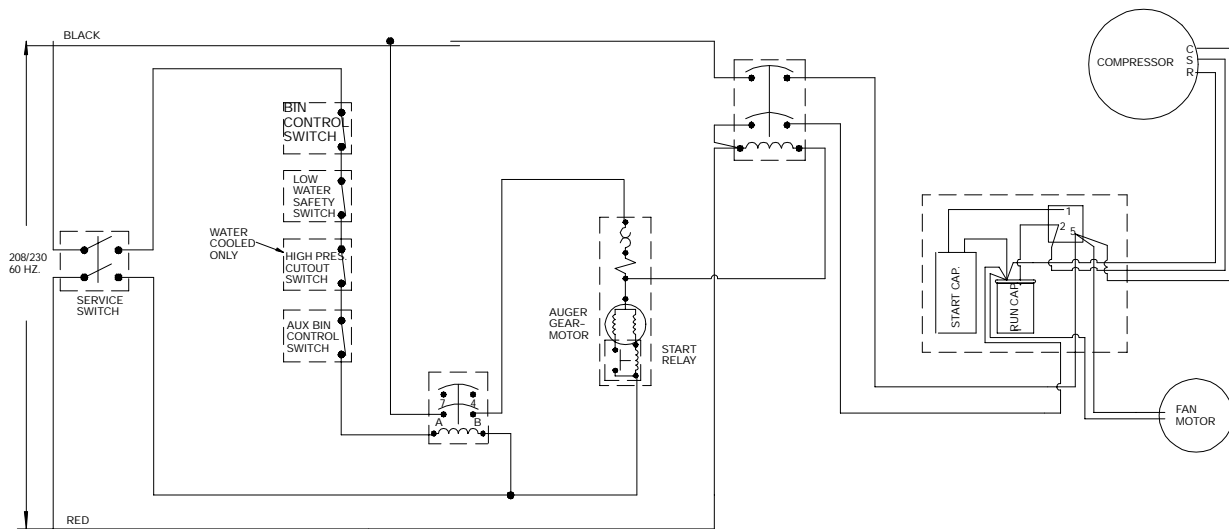

FIGURE 8. SCHEMATIC AND WIRING DIAGRAM WCC701-A, WCC701-W, WCC1001-A, WCC1001-W, WCF711-A, WCF711-W, WCF1101-A, & WCF1101-W

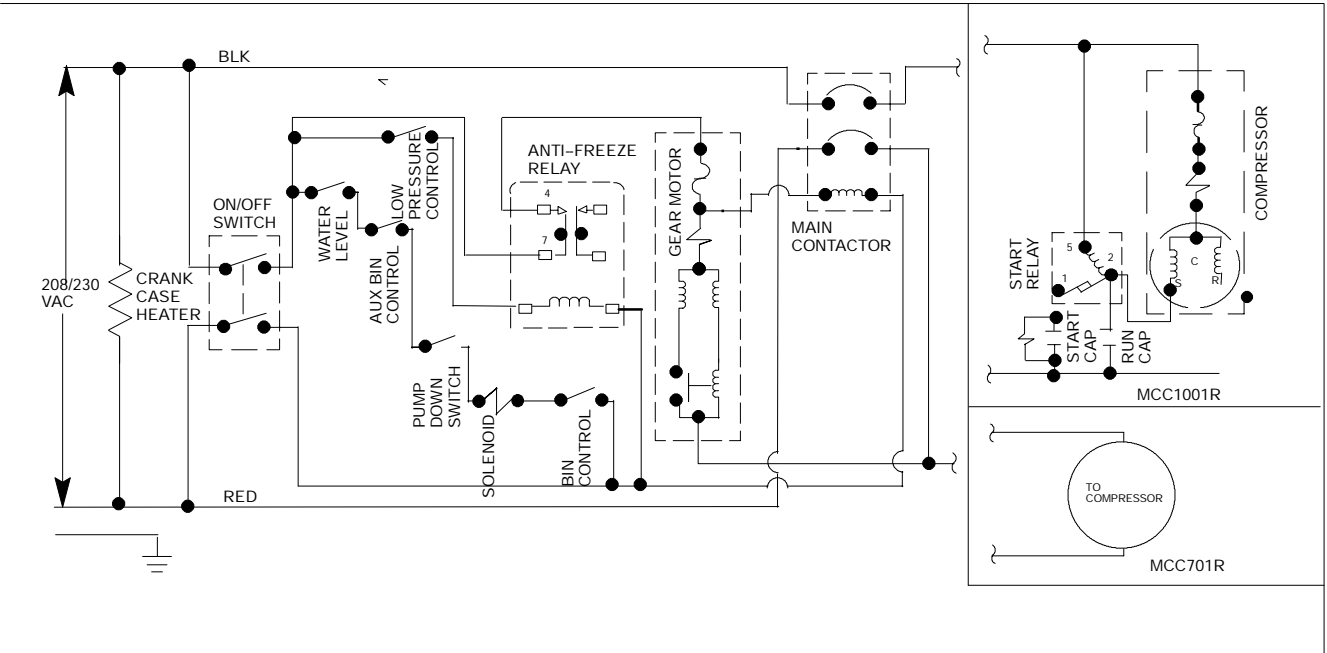

FIGURE 9. SCHEMATIC AND WIRING DIAGRAM WCF1101R, WCC1001R, WCF1102R, & WCC1102R

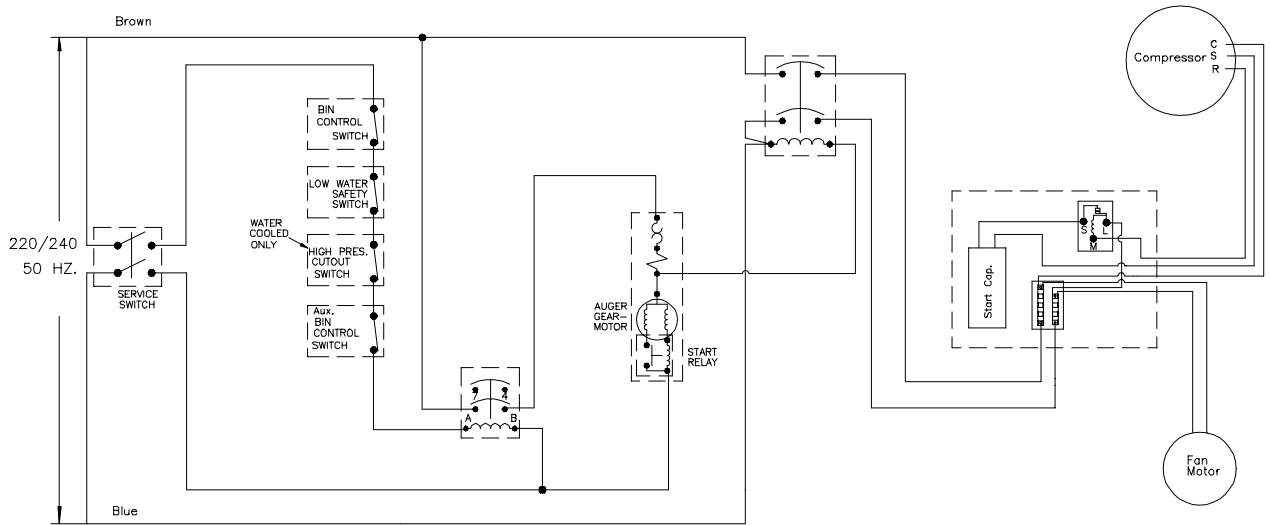
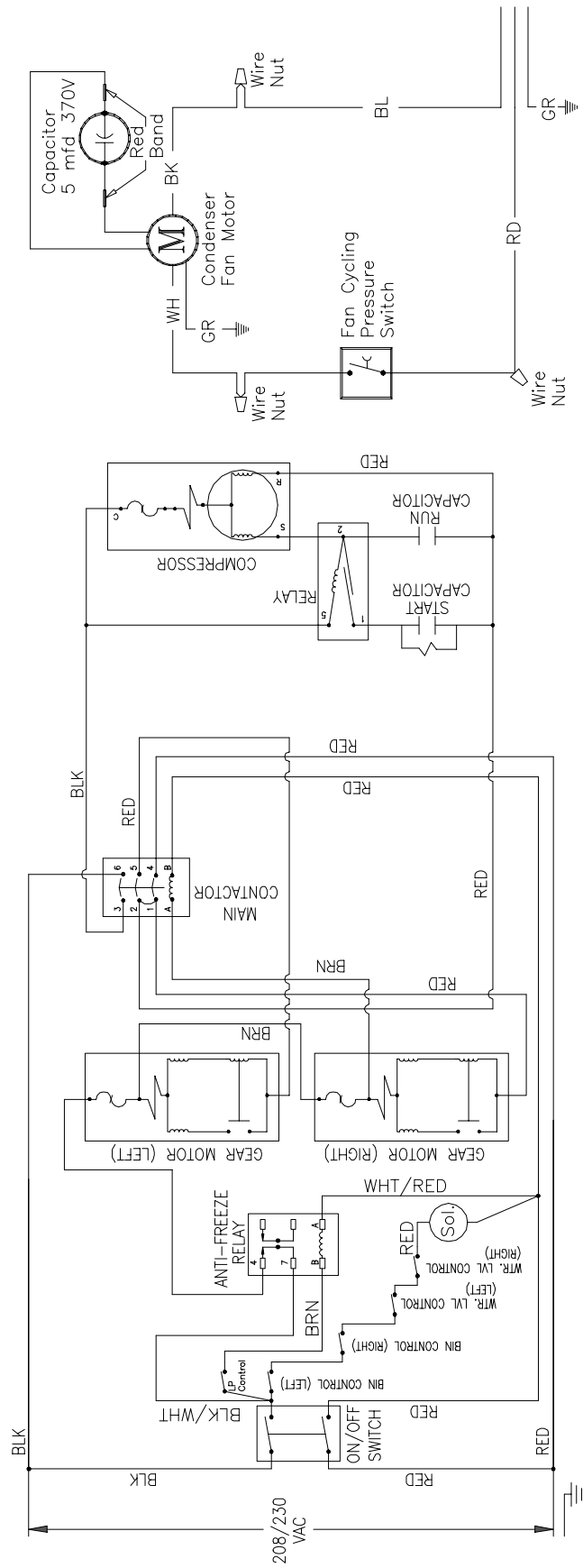

FIGURE 10. SCHEMATIC AND WIRING DIAGRAM WCC502, WCC702, WCC1002, WCF512, WCF712, & WCF1102



Schematic WCC2001-R and WCF2201-R

FIGURE 11. SCHEMATIC AND WIRING DIAGRAM WCC2001-R AND WCF2201-R

GUIDE TO SERVICE

ICEMAKER CLEANING AND SANITIZING PROCEDURES

Do not use any of the ice made during cleaning operations.

Clean and sanitize ice storage area when cleaning icemaker.

1. Turn machine off.
2. Shut off water supply.
3. Remove ice from storage bin.
4. Mix approved cleaner (2 gallons as directed). Recommended cleaner: Calgon Corp. of Virginia Chemicals, ice machine cleaner. Mixture: 3-1/3 ounces per gallon of water.
5. Clean auger/diverter assembly and ice transition/drop tube in a sink using cleaner mixture and reinstall in icemaker. Using cleaner, wipe down the dispense tray.
6. Turn machine on and add cleaner solution to water level control until 2 gallons have been used.
7. Turn on water supply and run machine for 15 minutes.
8. Turn off machine and remove all ice.
9. Sanitize using household liquid bleach (50 ppm chlorine). Mixture: 1 fluid ounce per gallon room temperature water. 2 minute exposure time.
10. Sanitize auger/diverter assembly and ice transition/drop tube in a sink using sanitizing solution and reinstall in icemaker. Using sanitizer, wipe down the dispense tray.
11. Fill icemaker with sanitizer by slowly pouring solution into water feed reservoir until full. Solution will drain through overflow tube. Do not run machine. Allow to air dry.
12. If icemaker is used in conjunction with ice dispenser or storage bin, follow manufacturer's recommended cleaning instructions at this time.

MAINTENANCE

Preventive maintenance can increase the trouble free life of your icemaker. Many authorized service agencies offer service contracts for your icemaker. Contact your local distributor for further information.

MONTHLY

1. Clean the condenser. Use a brush, vacuum cleaner or blow from inside with air or CO₂ gas.
2. Inspect water feed reservoir at least once a month until a definite pattern for cleaning and sanitizing has been established.

QUARTERLY

This is the maximum period of time between cleaning and sanitizing the icemaker. In addition to recommended monthly procedure, and if a more frequent cleaning and sanitizing pattern has not been established, unit must be cleaned and sanitized.

SEMI-ANNUALLY

Semi-Annually in addition to all previously established service procedures perform the following:

1. Check for water leaks in tube connections, water fittings and lower icemaker water seal.
2. Check drain tubes for clogs and aged tubes. Replace if tubes are stained or brittle.
3. Check for signs of condensation. Clean where necessary and replace insulation properly.
4. Check safety circuits for proper operation.
5. Check refrigeration system (see page 16).
6. Check unit for abnormal noise. Tighten machine and cabinet screws, if necessary.
7. Check white upper bearings on auger assembly. If bearings are less than $1/16$ " thick, replace. See Figure 12

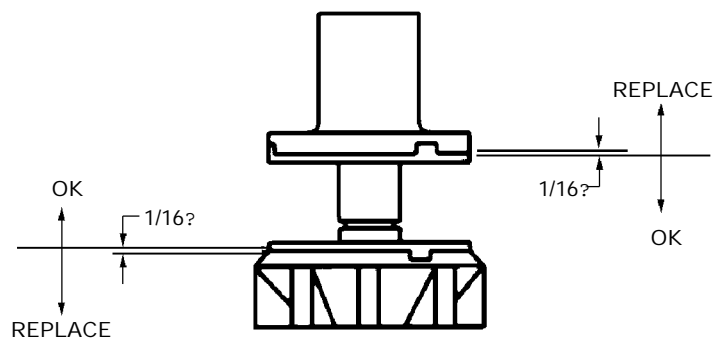

FIGURE 12. UPPER NUT AND BEARING ASSEMBLY

WATER LEVEL CONTROL

HOW WATER LEVEL CONTROL WORKS

When water is introduced through the inlet fitting the float rises. the float pushes against a lever which in turn forces the poppet assembly against the inlet fitting valve seat which seals the water off. See Figure 5 Before the water inlet is sealed the safety switch is operated. In the event of a water failure the float would drop down and operate the safety switch to shut off the machine.

If water level control will not shut off and seal at level as indicated, be sure inlet pressure does not exceed recommended factory operating range.

Under ordinary circumstances adjustment should not be necessary providing it was properly adjusted when unit was installed or relocated. If, however, the control becomes inoperative, repair or replace. See Start-Up Adjustment, page 9.

PURPOSE

1. To automatically maintain proper water level in the evaporator when unit is running and making ice.
2. A safety switch is operated in the event of an interruption in water supply. The switch shuts off the electrical power to the icemaker and its refrigeration system. Switch will reset as soon as cause of water failure has been corrected and proper water level in icemaker has again been reached.
3. The transparent bowl not only provides a visible check of water level, but also is a good guide to the internal conditions which exist within the icemaker assembly itself. (See Cleaning Procedure.)

TO REPLACE WATER LEVEL CONTROL

1. Shut off the water supply. Shut off the main power switch or unplug the ice dispenser from electrical outlet.
2. Remove the flexible tubing from bottom of water level control and drain water from water level control and evaporator.
3. Remove flexible tubing at bottom of water level bowl connected to the overflow.
4. Hold water inlet fitting with proper tool to prevent it from rotating when disconnecting the water inlet.
5. Remove wing nut holding water control to its mounting bracket. Control can be removed by lifting straight up.

TO REPLACE WATER LEVEL SAFETY SWITCH

1. Shut off main power switch or unplug the ice dispenser from electrical outlet.
2. Unplug molex connector connecting switch to electrical box.
3. Remove the 2 screws anchoring the water level safety switch to the bottom of the water level control mounting bracket.

REFRIGERATION SYSTEM

NOTE: Thermostatic Expansion Valve NO Adjustment

- 10 lbs. Discharge Pressure
Water Temperature

		WCC 500			WCC 700			WCC 1000			WCC 2200		
		40_	65_	90_	40_	65_	90_	40_	65_	90_	40_	65_	90_
Air Temperature	50_	162	166	168	174	177	180	170	171	172	200	201	203
	60_	188	192	194	202	205	208	198	199	200	218	219	220
	70_	214	218	220	230	233	236	226	227	228	251	253	254
	80_	245	249	251	265	269	272	261	263	264	297	298	300
	90_	275	279	281	300	304	307	296	298	299	308	330	332
	100_	309	313	315	328	334	340	324	328	332	362	364	366

REFRIGERATION SYSTEM ADJUSTMENTS

A complete understanding of the icemaker and hermetic refrigeration system is necessary before any adjustments are made. The refrigeration technician must use high and low side pressure readings, water and air temperatures, plus general conditions of cleanliness to assess the refrigeration system status when making any adjustments.

All icemaker products are tested and adjusted at the factory prior to shipment where the ambient temperature ranges from 65_ to 90_ F, depending on the season of the year.

Whenever a new icemaker product is initially installed and started-up, it is imperative that the start-up operation make the following checks and/or readjustments for local conditions.

EXPANSION VALVE

You will find a thermostatic expansion valve on icemakers, which is used to control the amount of refrigerant flowing through the evaporator. Improperly installed or defective expansion valves may cause low production, soft ice, squeaking from evaporator and excessive load inside evaporator.

By using general refrigeration system troubleshooting along with the pressure charts you can easily determine whether or not the expansion valve is working properly.

ADJUSTMENT AND TROUBLESHOOTING

When troubleshooting the expansion valve you must first be sure you have adequate water flowing into evaporator, a clean condenser, unit is properly ventilated, and system is properly charged and free from any restrictions. Also be sure compressor is operating properly.

Second, take reservoir water temperature and air temperature from condenser inlet and determine at what pressure unit should be running. Machines are equipped with thermostatic valves, there is NO adjustment. If correct pressure cannot be obtained, first be sure system has time to stabilize 10-15 minutes. Second, be sure sensing bulb is located at 12:00 position on outlet side of evaporator about 3-4 inches away from evaporator and be sure to insulate well and clamp tightly to tubing. If system pressures are still not adequate, take a second water and air temperature reading and go over other parts of system for possible problems. If proper charge is questionable evacuate and recharge to nameplate and leak check. If valve still malfunctions replace valve.

When replacing valve be sure to bleed refrigerant gas from low side port so as not to lose refrigerant oil. Use general refrigerant system practices when replacing and recharging unit. After new valve is in place, go through previous monitored adjustments and troubleshooting to be sure valve is functioning properly.

NOTE: Units with thermostatic expansion valve— valve is located on bottom refrigerant line. Sensing bulb is located on top refrigerant line. On water cooled units adjust condenser modulating valve before troubleshooting expansion valve.



CAUTION: Very high discharge pressure is present in system. Quick disconnects on your gauges will minimize danger and loss of refrigerant. Comply with federal regulations for reclaiming refrigerant.

CONDENSER MODULATING VALVE

The reason for using a water modulating valve is to supply the correct amount of water to the condenser, and to maintain a proper operating pressure to refrigeration system high side.

The flow of water through the valve is increased as the high side pressure rises and is decreased as high side pressure lowers.

To calibrate the amount of water flow with the refrigeration system high side pressure, turn adjustment screw located on end of valve opposite of bellows. See Figure 14. Turn screw counterclockwise to raise opening point or clockwise to lower opening point. Opening point of valve should be set to maintain proper operating pressure in refrigeration system high side. Refer to Pressure Chart on page 16. Closing point of valve should be set low enough to close valve during compressor stand-by periods.

NOTE: Cold water will absorb heat faster than warm water. The water flow will therefore automatically increase as inlet temperature increases.

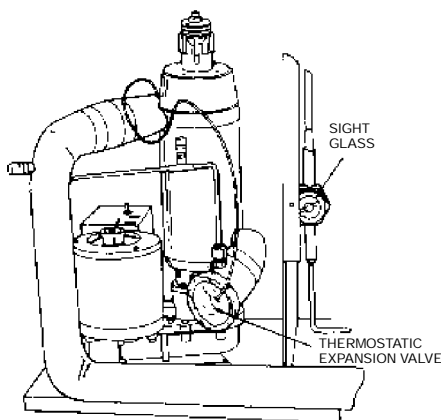
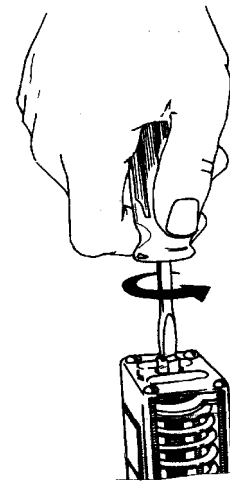

FIGURE 13. EXPANSION VALVE



F

SCREW

CONDENSER MODULATING VALVE REMOVAL

1. Disconnect power to unit, then shut off water supply to condenser and evacuate refrigerant from system.
2. Remove inlet water line from Condenser Modulating Valve. Also remove tube from high side refrigerant line.
3. Remove Condenser Modulating Valve and bracket from unit.
4. Remove valve from bracket.
5. Replace Condenser Modulating Valve by reversing Steps 2 thru 4. Then pull system into vacuum.
6. Charge unit with proper amount of refrigeration.
7. Turn power and water on to unit.
8. With unit running, adjust modulating valve to proper setting.
9. Go through a complete system check.

BIN CONTROL

The type of bin control used on all WCC Models is thermostatically controlled. The switch itself is inside the electrical box and can be serviced from the front of the unit. The cap tube bulb is located directly under the ice chute.

To test switch, disconnect power to unit and remove one wire from switch. Connect both leads of your ohmmeter to the Bin Control Switch terminals. With control bulb at room temperature ohmmeter should read "Closed Circuit". Refer to Figure 15

Now cover the control bulb with ice, within 1 minute switch should "click" and ohmmeter should read "Open Circuit."

The Bin control is in electrical series with coil on antifreeze relay along with the low water safety. If unit is water cooled, the condenser high pressure cut out is also in series.

The Control Switch is held in place inside electrical box by 2 screws. Control bulb is positioned under ice chute and can be replaced by removing screw that holds bracket to base of unit. With control and bracket removed, slip bulb off end of bracket.

The most important thing to remember when replacing probe is to be careful not to cut or kink probe and be sure sensor bulb is located in a position to shut unit down before ice reaches ice chute.

This icemaker is equipped with a safety ice level sensor. This sensor control is located on the dispense tray cover. This switch is also in electrical series with the anti-freeze relay and other safety circuitry.

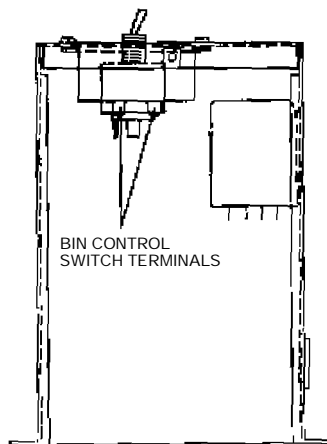

FIGURE 15. BIN CONTROL SWITCH

GEARMOTOR

The gearmotor is equipped with a start relay and a manual reset overload.

When current is applied, the relay energizes and completes the circuit to the start winding. The motor reaches a predetermined speed and the relay drops out, disconnecting the start winding. The run winding remains in the circuit as long as current is applied.

The purpose of the overload is to automatically shut off the motor in the event of a mechanical bind of the transmission, an overload condition within the evaporator or an electrical malfunction. It does this by sensing amperage draw. If the motor stalls the start relay would energize and stay energized. The amperage would surge 5 to 6 times greater than the normal draw. In this event the overload would shut off the transmission in 4 to 8 seconds.

If the motor is subjected to an abnormal load, but does not reach a stall condition, the overload will react, but over a greater period of time. The reaction time depends upon the amperage to which it is subjected.

The overload, through the safety circuit, also shuts off the compressor.

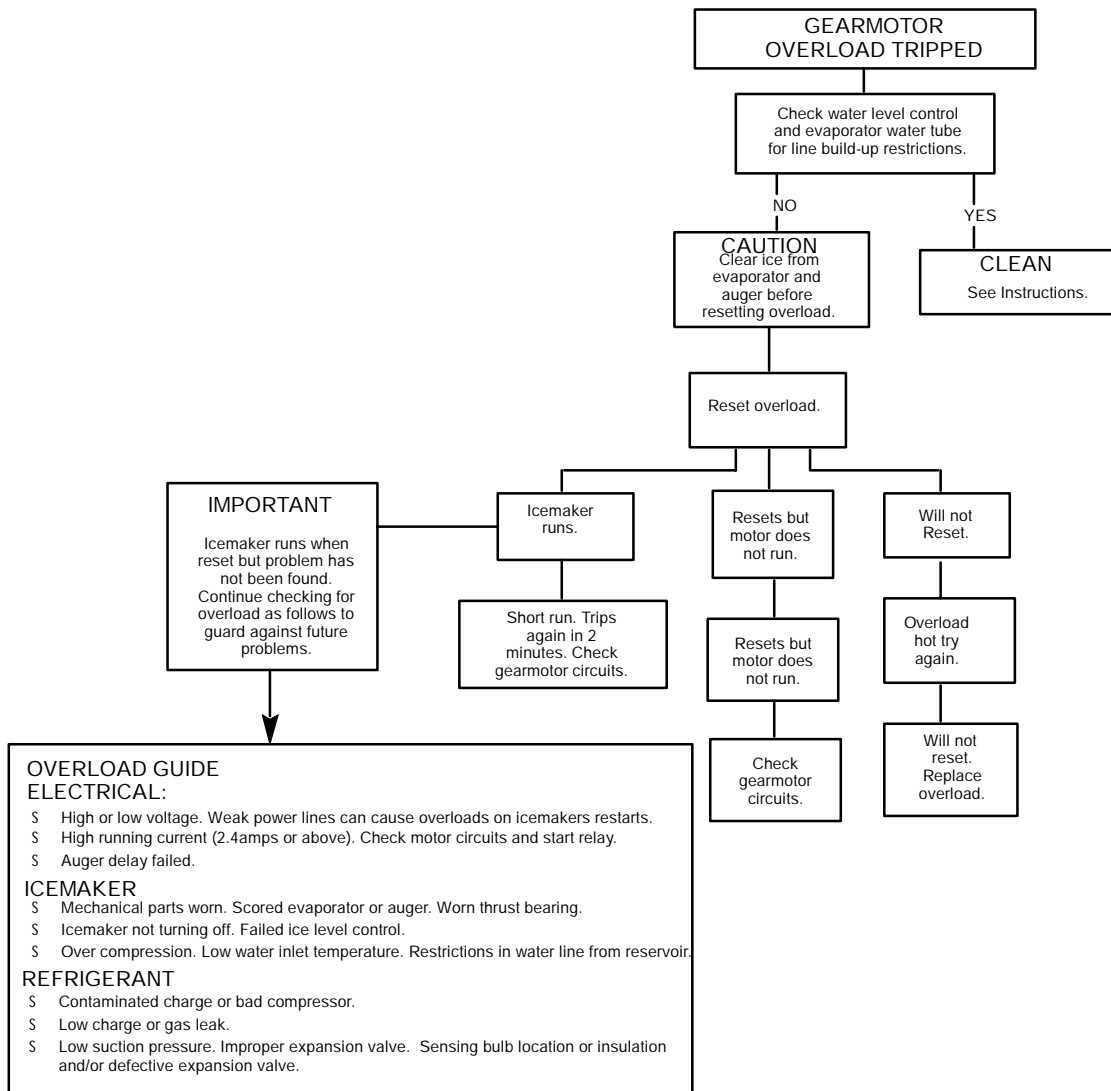

MOTOR CHECK

The resistance readings on the winding will be between 5 to 25 ohms. A meter capable of these low readings must be used. The start relay cover must be removed. (See Figure 16).

If no continuity on start or run winding test, replace gearmotor. If continuity on grounded motor test, replace gearmotor.

START RELAY

1. Check between "2" and "4" on relay (with relay unplugged). If there is continuity replace the relay, as the relay contacts should be open.
2. Check between "3" and "4" on relay, if no continuity replace the relay.

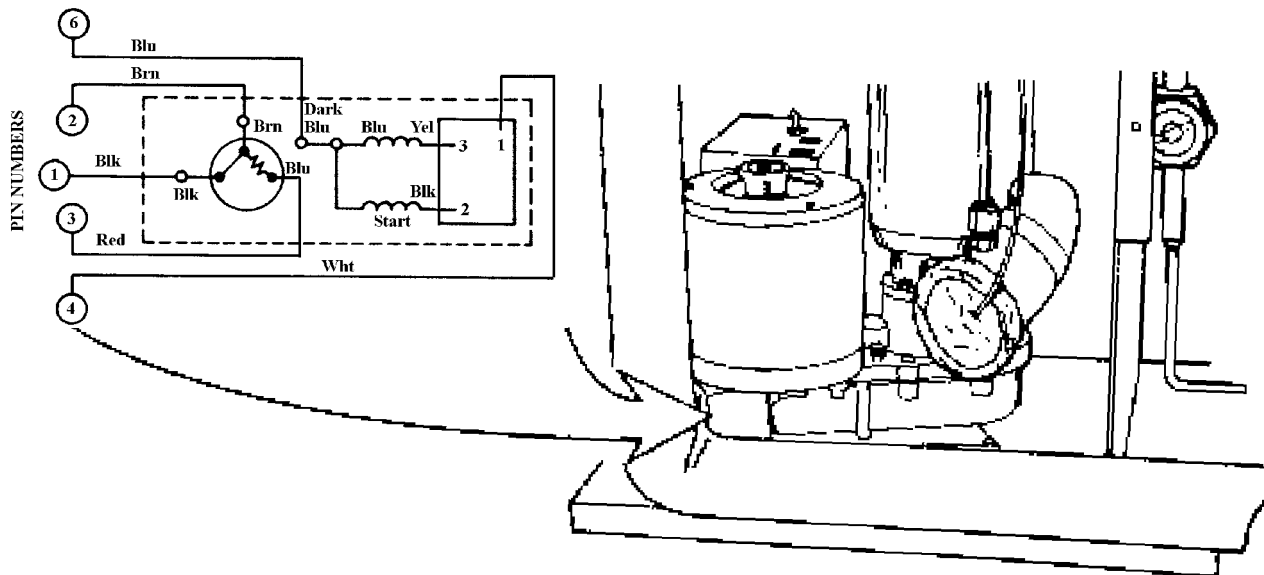

FIGURE 16. GEARMOTOR ASSEMBLY

TO REPLACE GEARMOTOR ASSEMBLY

1. Disconnect the icemaker from the electrical power source.
2. Disconnect the transmission cable from the electrical box.
3. Remove the 4 hex head bolts securing the evaporator to the top of the transmission.
4. Remove the 4 bolt's holding the transmission and bracket to frame base, while supporting the weight of the evaporator. Remove the transmission from the unit.
5. When replacing the transmission, it may be necessary to rotate the auger back and forth to align the motor shaft and auger.

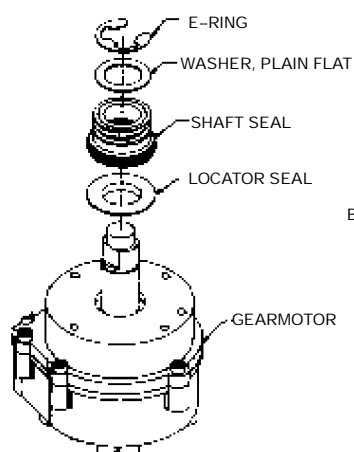

FIGURE 17. SHAFT SEAL 500

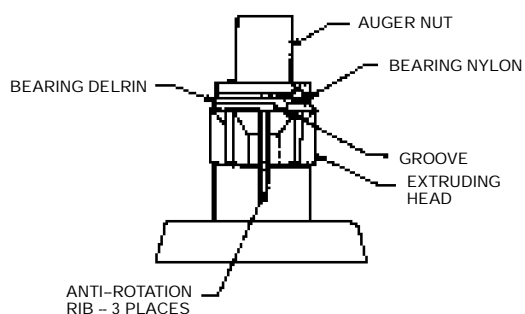
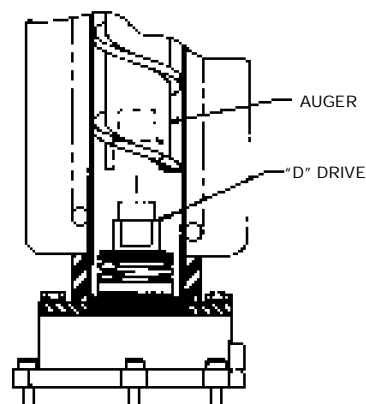

FIGURE 18. AUGER AND EXTRUDING HEAD REMOVAL



INSTALLATION AND SHAFT SEAL REPLACEMENT 500(See Figure 17)

1. Place shaft seal locator seat over gear motor output shaft, embossed side down, and push down until shaft seal seat rests flush on top of gear motor.

2. Place rubber coated ceramic seal (important: ceramic face up) over output shaft and push down until seal rests on top of the shaft seal seat. (Lubricate rubber on ceramic seal with rubber lubricant.)
3. Place shaft seal with carbon face down (spring up) over output shaft and push (gently) downward until seal rests on ceramic face of the output shaft seal.
4. Place flat washer over output shaft and let rest on the output shaft seal. Push down on the washer compressing the spring on the output shaft seal. While holding the seals (down) in place slide the E-ring into the groove on the output shaft.

AUGER AND EXTRUDING HEAD REMOVAL

1. Disconnect unit from power supply.
2. Remove storage container cover and put aside.
3. Turn off water supply to icemaker.
4. After ice has melted from head take hold of the auger nut and lift straight up to disengage from icemaker.
5. When replacing the auger assembly, make certain that both the auger engages the output shaft drive and the extruding head ribs engage the evaporator tube. (See Figures 18)

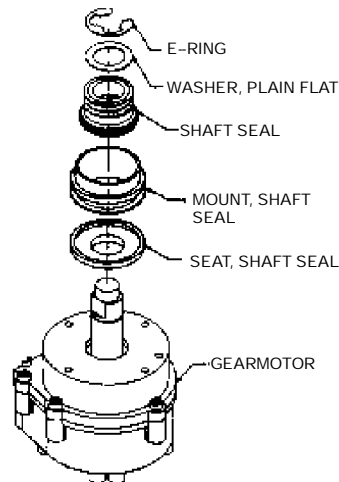

FIGURE 19. SHAFT SEAL 700 & 1000

INSTALLATION AND SHAFT SEAL REPLACEMENT 700 & 1000 (See Figure 19)

1. Place shaft seal locator seat and shaft seal mount over gearmotor output shaft and push down until shaft seal seat and shaft seal mount rest flush on top of gearmotor.
2. Place rubber coated ceramic seal (important: ceramic face up) over output shaft and push down until seal nest in recess of shaft seal mount. (lubricate rubber on ceramic seal with rubber lubricant).
3. Place shaft seal with carbon face down (spring up) over output shaft and push (gently) downward until seal rests on carbon face of the output shaft seal.
4. Place flat washer over output shaft and let rest on the output shaft seal. Push down on the washer compressing the spring on the output shaft seal. While holding the seals (down) in place slide the E-ring into the groove on the output shaft.

UPPER NUT AND BEARING ASSEMBLY

The upper white bearing located on top of the auger is used to absorb the force between the auger and extruding head.

NOTE: The bearings are 3/32" thick. When they wear below 1/16" they should be replaced. Bearings to be inspected for wear during quarterly maintenance. (See Figure 12)

To Replace Bearing

1. Disconnect unit from electric power.
2. Remove top panels.
3. Remove Dispense Tray Cover.
4. Use an open end wrench on auger nut connected to bearing and turn counterclockwise to remove assembly.
5. Remove worn bearings. Replace with new bearings and then reinstall assembly.

NOTE: If auger turns with nut, remove cover on top of gearmotor stator and hold motor while loosening nut.



FIGURE 20. OVERLOAD CHECK

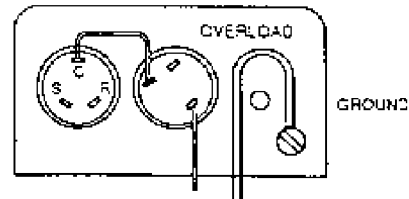

FIGURE 21. COMPRESSOR CHECK

ELECTRICAL CHECKOUT

1. Be sure the unit is disconnected from the power source. Remove the compressor electrical box cover. Check for obvious damage and loose wires.
2. Disconnect the fan motor leads. Since capacitors store energy, short the capacitor with a screwdriver. This will prevent shocks.
3. Disconnect the compressor terminal wires.

OVERLOAD CHECK (See Figure 20)

4. Using a volt-ohmmeter check the continuity across the overload, contact #1 and #3. If none, wait for unit to cool down and try again. If still no continuity, the overload protector is defective and should be replaced.

COMPRESSOR CHECK (See Figure 21)

The resistance readings on the windings will be between 0.25 to 10.00 ohms, a meter capable of these low readings must be used.

5. Check between "C" and "R." Replace the compressor if there is no continuity as the run windings are open.
6. Check between "C" and "S." Replace the compressor if there is no continuity as the start windings are open.
7. Check between "C" and "R" or "S" and the shell of the compressor. If there is continuity, replace the compressor as the motor is grounded.
8. Check between screw terminal on the overload and "C" on the compressor. Check and repair the lead or connections if there is no continuity.

CAPACITOR CHECK

9. Check or replace start capacitor, disconnect bleed resistor before checking for shorted capacitor.
10. Check or replace run capacitor (if supplied) check for shorted capacitor or either terminal grounded to case.

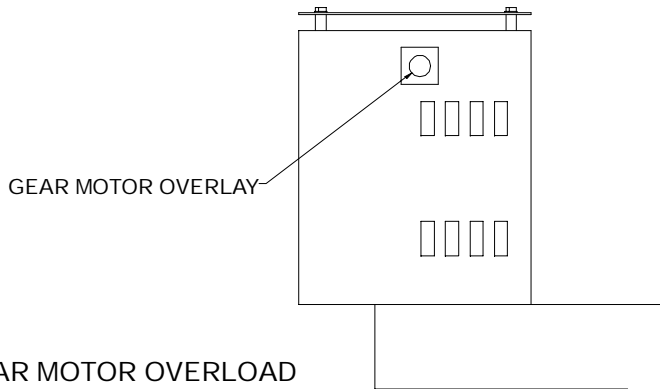

FIGURE 22. GEAR MOTOR OVERLOAD

SAFETY CONTROLS

Your icemaker unit has several safety and control devices incorporated into its design.



WARNING: None of the below described devices should ever be “bypassed” to allow the unit to function.

The safety and control system shut-off devices are:

1. Low water shut off reed switch located in icemaker float assembly. (Automatic reset type.)
See Figure 5
2. Gearmotor thermal overload, manual reset type (red button on motor). See Figure 22
3. Compressor thermal overload, automatic reset type. See Figure 20
4. Anti-freeze relay and associated circuit. See wiring diagrams, pages 10 and 11.
5. Main service switch located on top of the control box. See Figure 15
6. Bin Control. See Figure 15
7. High pressure cut out (water cooled only).

GUIDE TO GOOD ICE

CUSTOMER COMMENTS

CHECK ICEMAKER LOCATION CONDITIONS FIRST

CHECK ICE MAKER

"It runs but the ice is too soft."
 "The icemaker is not producing enough ice."
 "The ice is too wet."



- S Proper air flow for condensing system.
- S Location too close to high units such as coffee urns, deep fryers, grills, etc.
- S Supply water conditions
 - Water too warm (above 90_F).
 - Water artificially softened above 262 ppm sodium chloride.
 - Normal water supply too high in total dissolved solids (above 500 PPM).

- S Use gauges for checking suction and head pressures. See manual for correct reading and conditions. Check frost line and sight glass.
- S Check water level for proper adjustment and restrictions. See Manual.
- S Check evaporator assembly for worn parts, bearings, scored evaporator and auger, bad expansion valve, etc.

"It makes too much noise."
 (With this comment the ice is usually extremely hard and larger than normal.)



Over Compression

- S Check to see if noise objection is normal fan and air flow noise.
- S Supply water conditions.
 - Water too cold (below 50_F). (Possibly running from pre-cooler.)
- S Obstructions partially blocking ice exit from top of evaporator.
- S Check fan and fan shroud.

- S Check for loose parts and screws rattling.
- S Check evaporator assembly for worn parts, bearings, scored evaporator and auger, bad expansion valve, etc.

TROUBLESHOOTING CHART – ICEMAKER NOT OPERATING

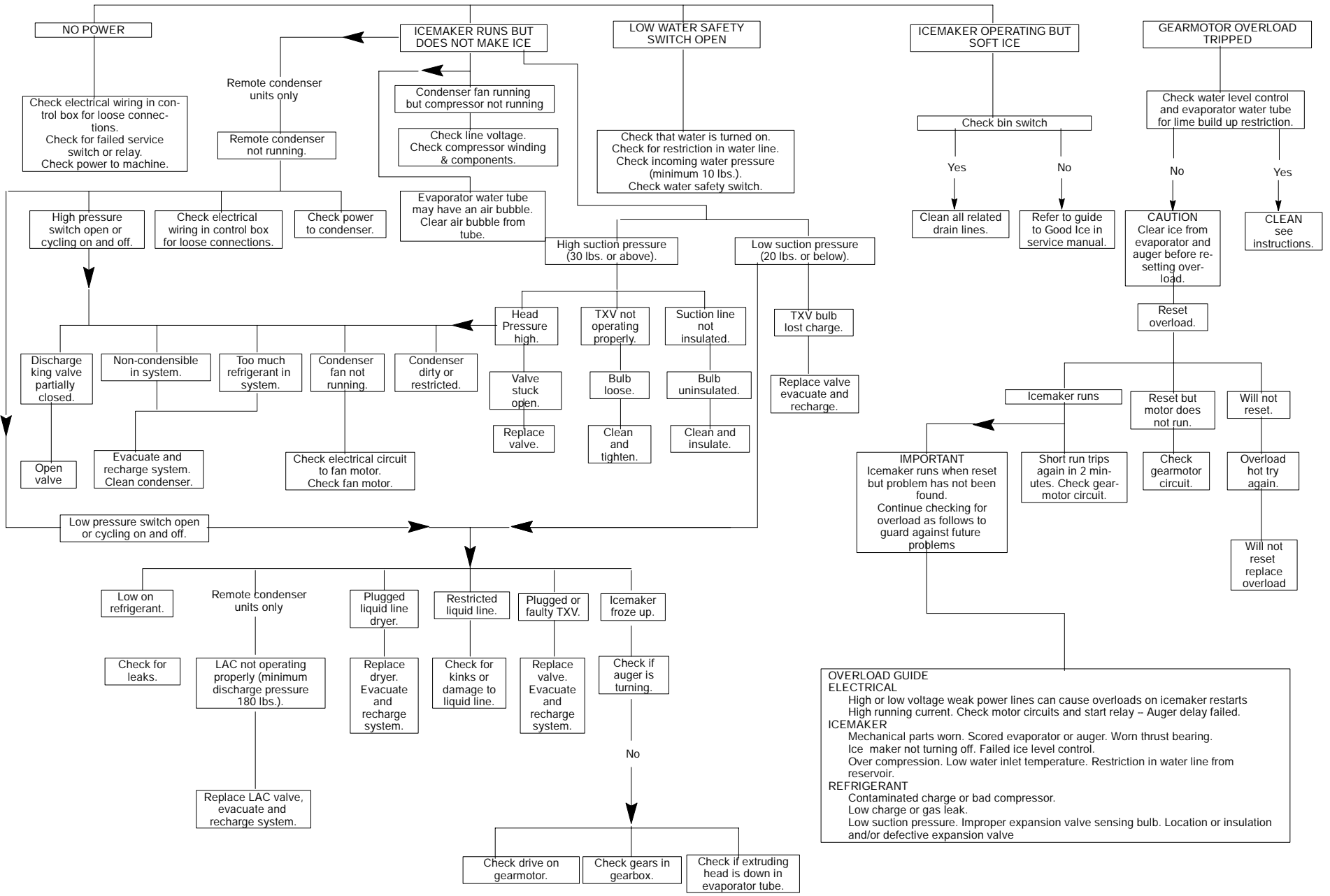

OVERLOAD GUIDE

ELECTRICAL
 High or low voltage weak power lines can cause overloads on icemaker restarts
 High running current. Check motor circuits and start relay – Auger delay failed.

ICEMAKER
 Mechanical parts worn. Scored evaporator or auger. Worn thrust bearing.
 Ice maker not turning off. Failed ice level control.
 Over compression. Low water inlet temperature. Restriction in water line from reservoir.

REFRIGERANT
 Contaminated charge or bad compressor.
 Low charge or gas leak.
 Low suction pressure. Improper expansion valve sensing bulb. Location or insulation and/or defective expansion valve

THIS PAGE LEFT BLANK INTENTIONALLY

TROUBLESHOOTING

IMPORTANT: Only qualified personnel should service internal components or electrical wiring.

TROUBLESHOOTING COMPRESSORS

Trouble	Probable Cause	Remedy
Basically the compressor problems can be narrowed down to three areas of checkout.		
THE COMPRESSOR WILL NOT RUN	A. No voltage to the compressor terminals.	A. Check circuit.
	B. Low voltage.	B. Below 90% of nameplate rated voltage.
	C. Problems in the compressor electrical circuit.	C. See electrical checkout instructions.
THE COMPRESSOR STARTS BUT TRIPS REPEATEDLY ON THE OVERLOAD PROTECTOR	A.	A. Check for proper fan operation and clean condenser.
	B.	B. Check the compressor suction and discharge pressures.
	C. Voltage.	C. Voltage should be within 10% of the rated nameplate voltage.
	D. High compressor amperage draw.	D. It should never exceed 120% of the rated nameplate amperage. See electrical checkout instructions.
THE COMPRESSOR RUNS BUT WILL NOT REFRIGERATE	A. Compressor not working.	A. Check the compressor suctions and discharge pressures. See chart on page 16.

THIS PAGE LEFT BLANK INTENTIONALLY

PARTS LIST

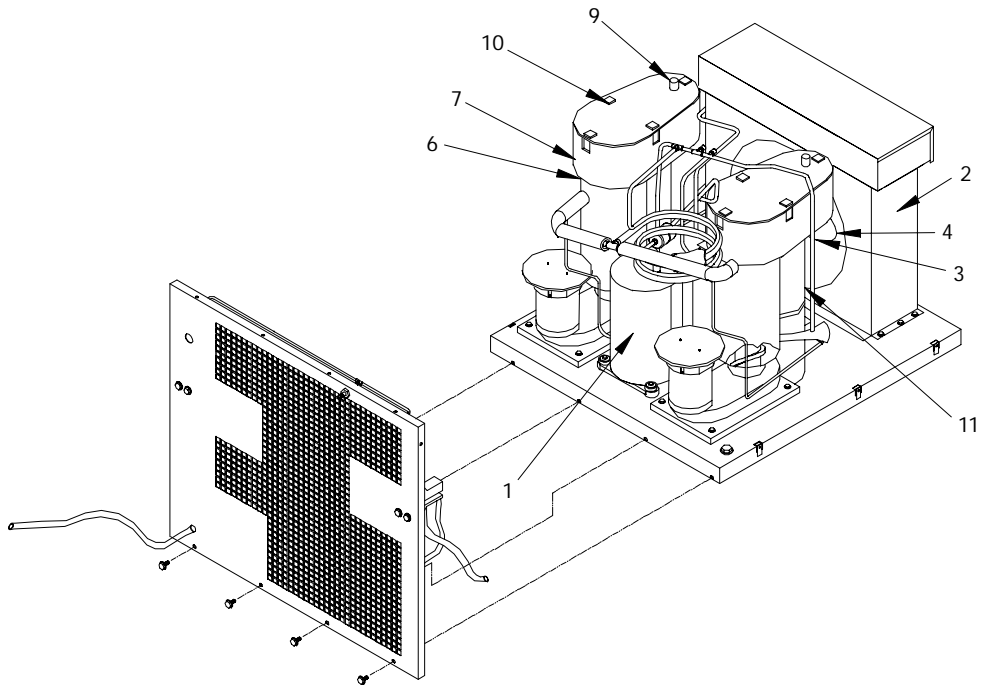

FIGURE 23. REFRIGERATION AND ICEMAKER ASSEMBLY MODEL 2000 SERIES
EXPLODED VIEW AND PARTS LIST

Item No	Part No	Description
1	162964027	Compressor (WCC2001 and WCF2201)
	162964046	Compressor (WCC2002 and WCF2202)
2	638036849	Condenser (WCC and WCF Air)
	27177	Condenser (WCC and WCF Water)
	161870007	Condenser (WCC and WCF Remote)
3	638090344001	Fan Motor (WCC and WCF Air 50 and 60 HZ)
	27185	Fan Motor (Remote 50 and 60 HZ)
4	63809034401	Fan Blade (Air)
	630900246	Fan Blade (WCC and WCF Remote)
5	638004391	Bracket Fan Motor
6	638036087	Clamp, Dispense Tray
7	638036872001	Dispense Tray Assembly
8	638036882	Cover Dispense Tray
9	638036884	Detector Assembly Ice leve
10	638036867001	Clip Cove
11	638036020001	Drop Tube Assembly
12	638092537	Cover, Electrical Box
13	164980002	Water Regulator Valve (Water) (Not Shown)
14	638009755	High Pressure Switch (Water) (Not Shown)
15	161773003	Pressure Switch (WCC and WCF Remote) (Not Shown)
16	166226000	Valve Head Pressure (WCC and WCF Remote) (Not Shown)
17	166225000	Receiver (WCC and WCF Remote) (Not Shown)

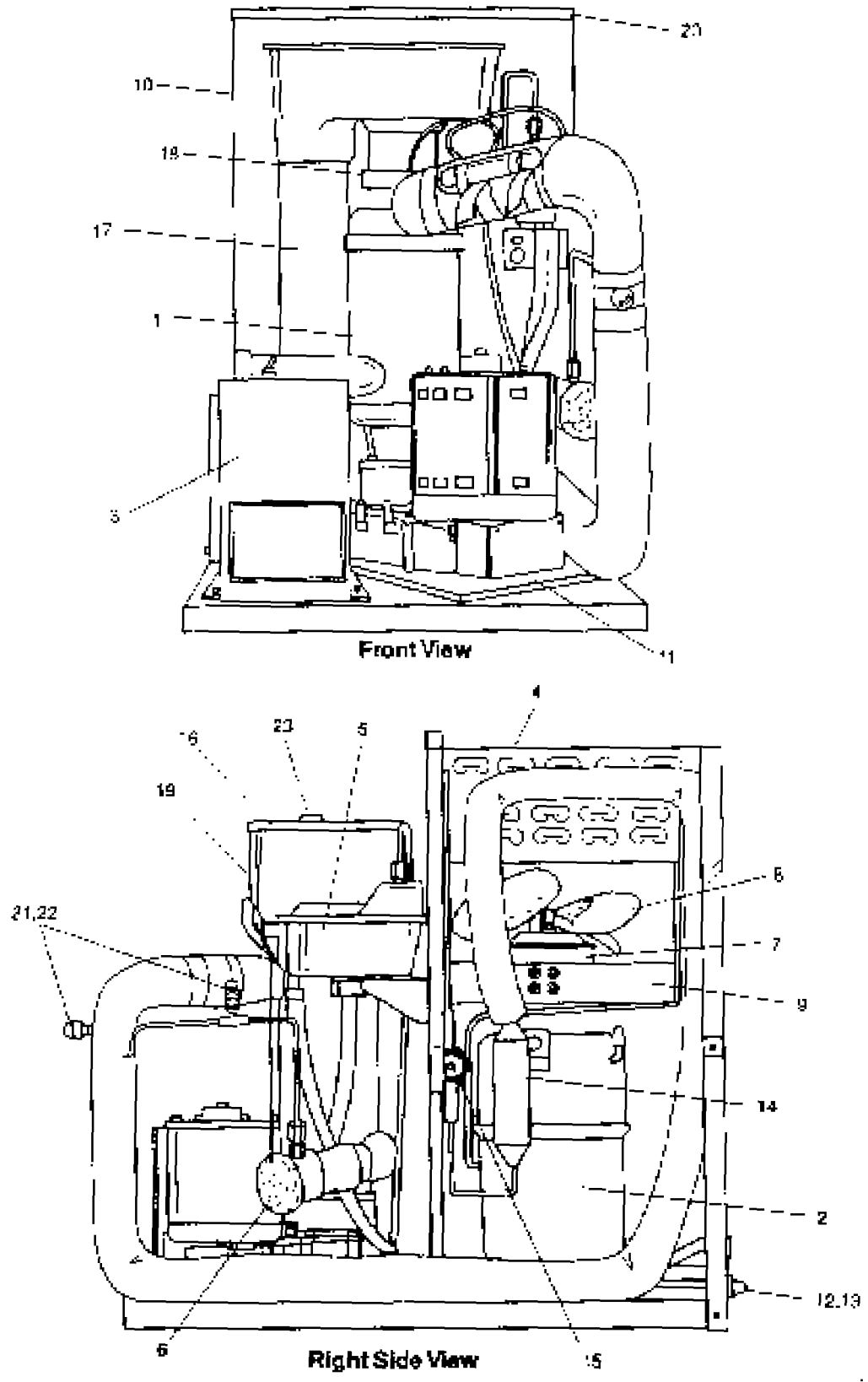

FIGURE 24. REFRIGERATION AND ICEMAKER ASSEMBLY MODEL 500 SERIES

REFRIGERATION AND ICEMAKER ASSEMBLY MODEL 500 SERIES

Item No.	Part No.	Description
18	638090130	Front End Assembly-WCC500
	638090130-002	Front End Assembly-WCC502
	638090143	Front End Assembly-WCC510
	638090143-002	Front End Assembly-WCC512
19	638090121	Compressor, 115V
	638090131	Compressor, 240V/50Hz.
20	638036295-01	Electrical Box Assembly-WCC500-A
	638036295-03	Electrical Box Assembly-WCC500-W
	638036295-05	Electrical Box Assembly-WCC502-A
	638036295-06	Electrical Box Assembly-WCF510-A
	638036295-08	Electrical Box Assembly-WCF510-W
	638036295-10	Electrical Box Assembly-WCF512-A
21	638008854	Condenser-Air Cool
	* 638036383	Condenser-Water Cool
22	638004643-05	Water Level Control Assembly
23	638090126	Expansion Valve
24	638036225-x	Fan Motor Assembly, 115V
	638010017	Fan Motor Assembly, 240V 50Hz
25	638008618	Fan Blade
26	638008814	Bracket, Fan Motor
27	638008812	Panel, Center
28	638036218	Bracket, Mounting Ice maker
29	638008409	Bulkhead Fitting
30	638007206-04	Nut, Jam 1/2-20
31	638004393	Dryer

Note: * = Not Shown

Item No.	Part No.	Description
32	638036865	Cover and Detector Assembly - Dispense Tray
	638036883	Cover, Dispense Tray
	638036867-001	Clip Cover
	33	638036366-x
34	638036269	Clamp, Dispense Tray
35	638036869-002	Dispense Tray Assembly
36	638031762	Gasket, Foam
37	638007383	Access Port
38	638007385	Replacement Cap
39	638036884	Detector Assembly-Ice Level
40*	638007208-03	Nut, Palnut, 3/4-16
41*	638007295	Bulkhead Fitting, Water Cool
42*	638009755	Pressure Switch
43*	638036386	Finger Guard, Fan
44*	638090021	Water Regulating Valve
45*	638036391	Exhaust Fan Assembly
46*	638090128	Compressor Electrical Box Assembly-WCC500, WCF510
	638090128-002	Compressor Electrical Box Assembly-WCC502, WCF512
47*	638090122	Relay Start 115V
48*	638090132	Relay Start 220V 50Hz
49*	638090124	Capacitor Start 115V
50*	638090134	Capacitor Start 220V 50Hz
51*	638090123	Capacitor Run 115V
37	638036267	Fan Shroud

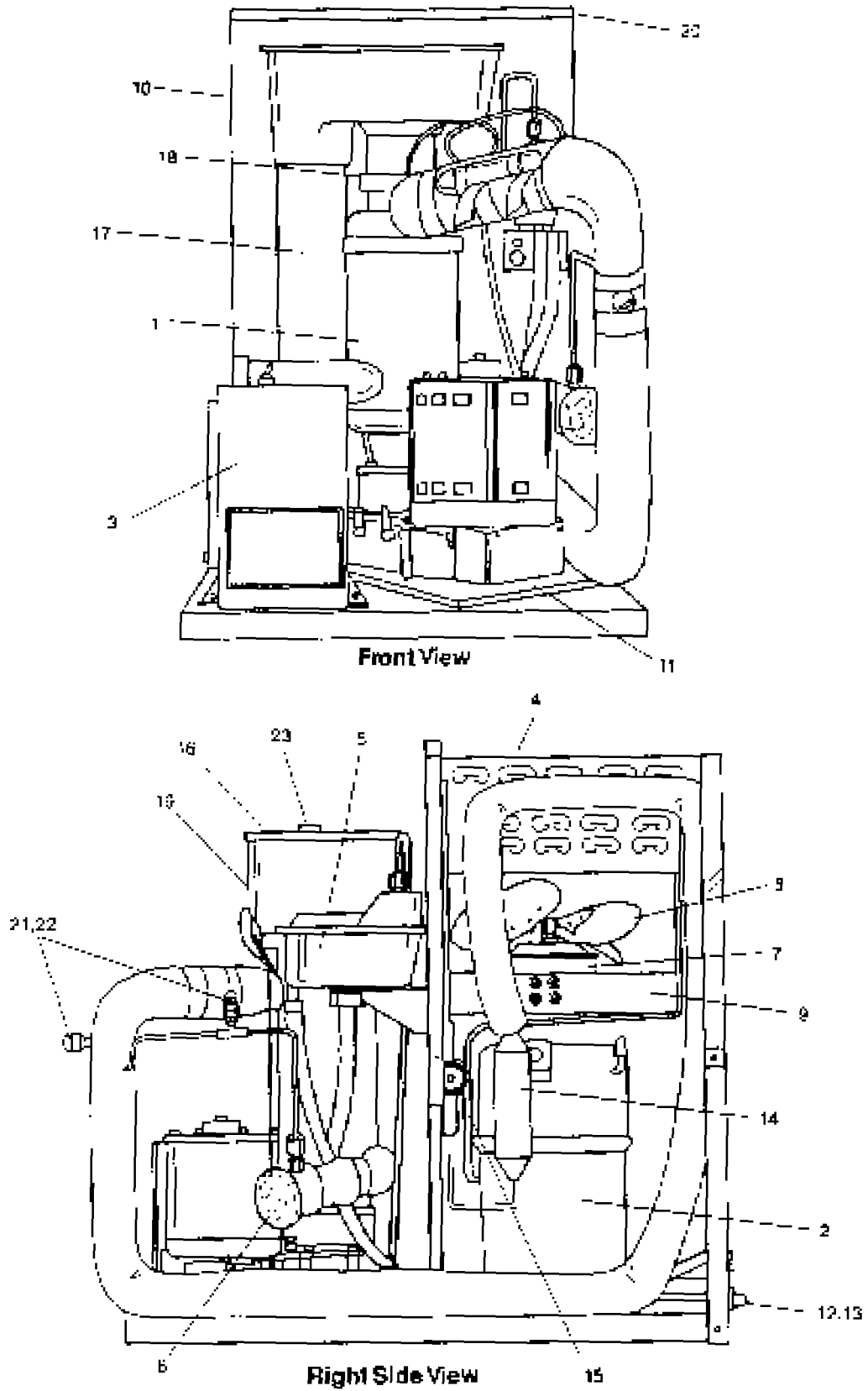

FIGURE 25. REFRIGERATION AND ICEMAKER ASSEMBLY MODEL 700 SERIES

REFRIGERATION AND ICEMAKER ASSEMBLY MODEL 700 SERIES

Item No.	Part No.	Description
1	638090230	Front End Assembly-115V
	638090230-001	Front End Assembly-208/230V
	638090230-002	Front End Assembly-220V 50Hz
	638090227	Front End Assembly-WCF710
	638090227-001	Front End Assembly-WCF711
	638090227-002	Front End Assembly-WCF712
2	638090221	Compressor, 115V
	638090241	Compressor 208/230V
	638090231	Compressor, 220V 50Hz.
3	638036295-01	Electrical Box Assembly-WCC700-A
	638036295-02	Electrical Box Assembly-WCC701-A, WCC702-A
	638036295-03	Electrical Box Assembly-WCC700-W
	638036295-04	Electrical Box Assembly-WCC701-W
	638036295-06	Electrical Box Assembly-WCF710-A
	638036295-07	Electrical Box Assembly-WCF711-A, WCF712-A
	638036295-08	Electrical Box Assembly-WCF710-W
	638036295-09	Electrical Box Assembly-WCF711-W
	4	638036273
638036272		Condenser-Water Cool
5	638004643-05	Water Level Control Assembly
6	638090226	Expansion Valve, Thermal
7	638090236	Fan Motor Assembly, 115V
	638090234	Fan Motor Assembly, 208/230V
	638090233	Fan Motor Assembly-220V 50 Hz
8	638096723	Fan Blade
9	638008814	Bracket, Fan Motor
10	638008812	Panel, Center
11	638036218	Bracket, Mounting Ice maker
12	638008409	Bulkhead Fitting
13	638007206-04	Nut, Jam 1/2-20
14	638004393	Dryer

Item No.	Part No.	Description
15	638036865	Cover and Detector Assembly - Dispense Tray
	638036883	Cover, Dispense Tray
	638036867-001	Clip Cover
16	638036213-x	Drop Tube Assembly
17	638036269	Clamp, Dispense Tray
18	638036869-001	Dispense Tray Assembly
19	638031762	Gasket, Foam 3/4 x 3/4 x 13 Lg.
20	638007383	Access Port
21	638007385	Replacement Cap
22	638036884	Detector Assembly-Ice Level
23*	638007208-03	Nut, Palnut, 3/4-16
24*	638008834	Bracket, Mounting Condenser
25*	638009755	Pressure Switch
26*	638090021	Water Regulating Valve
27*	638036188	Receiver, Upright
28*	638036194	Valve, Head Pressure
29*	638037110	Washer Seal
30	638037111	Valve, Rotolock
31*	638037128-01	Crankcase Heater Assembly
32	638090232	Electrical Box Assembly Comp. WCC700 115V, WCF710
	638090232-001	Electrical Box Assembly Comp. WCC701 208/230V 60 Hz, WCF711
	638090232-002	Electrical Box Assembly Comp. WCC702 220V 50 Hz, WCF712
33	638090235	Condenser Shroud
34*	638090222	Relay Start 115V
35	638090242	Relay Start 208/230V 60 Hz
36*	638090238	Relay Start 220V 50Hz
37*	638090223	Capacitor Run 115V
38*	638090243	Capacitor Run 208/230V 60 Hz
39*	638090224	Capacitor Start 115V
40*	638090244	Capacitor Start 208/230V 60Hz
		Capacitor Start 220V 50Hz

Note: * = Not Shown

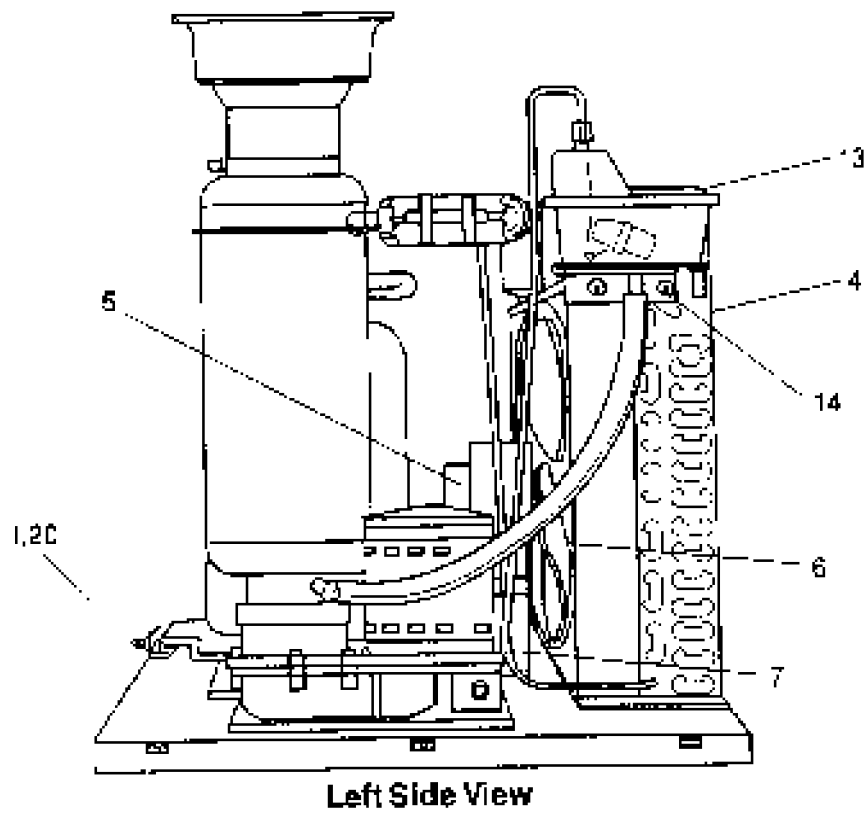
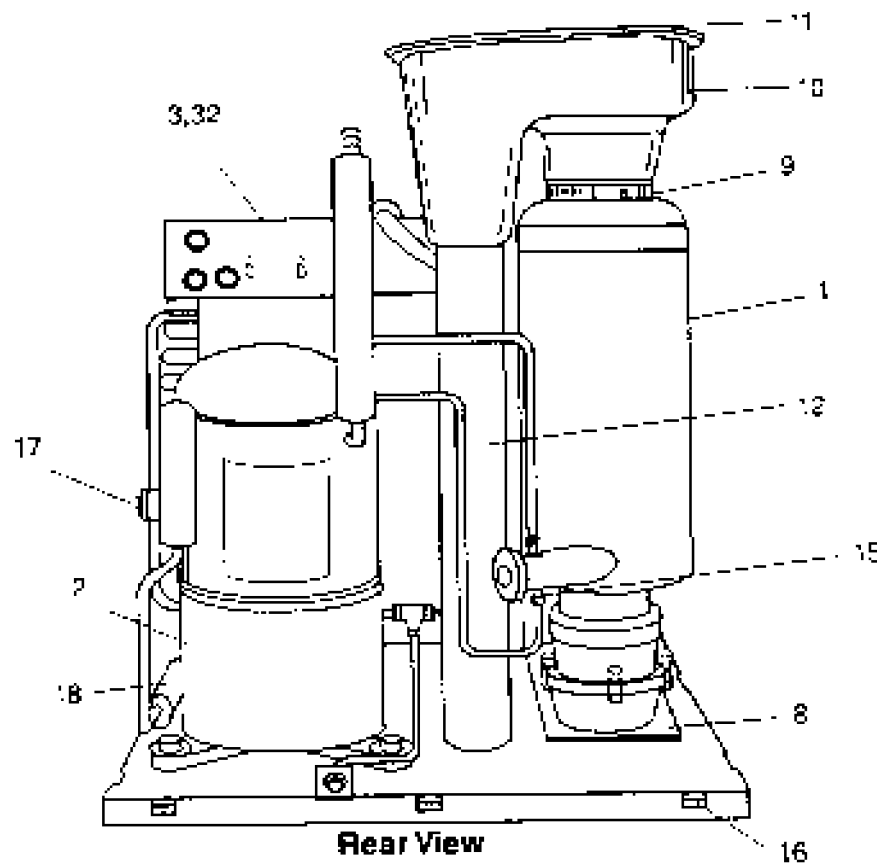

FIGURE 26. REFRIGERATION AND ICEMAKER ASSEMBLY MODEL 1000 SERIES

REFRIGERATION AND ICEMAKER ASSEMBLY MODEL 1000 SERIES

Item No.	Part No.	Description
1	638090330-001	Front End Assembly-208/230V WCC1000
	638090330-002	Front End Assembly-220V 50Hz WCC1002
	638090343-001	Front End Assembly-208/230V, WCF1101
	638090343-002	Front End Assembly-220V 50Hz WCF1102
2	638090321	Compressor, 208/230V
	638090331	Compressor, 220V 50Hz.
3	638090325-001	Electrical Box Assembly-WCC1001-A
	638090325-001	Electrical Box Assembly-WCC1001-W
	638090325-009	Electrical Box Assembly-WCC1001-R
	638090325-002	Electrical Box Assembly-WCC1002-A
	638090325-002	Electrical Box Assembly-WCC1002-W
	638090325-010	Electrical Box Assembly-WCC1002-R
	638090325-003	Electrical Box Assembly-WCF1101-A
	638090325-003	Electrical Box Assembly-WCF1101-W
	638090325-011	Electrical Box Assembly-WCF1101-R
	638090325-004	Electrical Box Assembly-WCF1102-A
	638090325-004	Electrical Box Assembly-WCF1102-W
	638090325-012	Electrical Box Assembly-WCF1102-R
4	638036121	Condenser-Air Cool
*	638009776	Condenser-Water Cool
5	638090344-001	Fan Motor Assembly, 208/230V
	638090344-002	Fan Motor Assembly, 220V 50Hz
6	638036011	Fan Blade
7	638004391	Bracket, Fan Motor

Item No.	Part No.	Description
8	638090349	Bracket, Mounting
9	638036087	Clamp, Dispense Tray
10	638036872-001	Dispense Tray Assembly
11	638036864	Cover and Detector Assembly - Dispense Tray
	638036884	Cover, Dispense Tray
	638036882	Cover, Dispense Tray w/o Detector
	638036867-001	Clip Cover
	638036884	Detector Assembly-Ice Level
12	638036020	Drop Tube Assembly
13	638090350	Water Level Control Assembly
14	638090347	Bracket, Water Level Control
15	638090326	Expansion Valve
16	638007262-01	Nut, Tinnerman
17	638090055	Dryer
18	638008409	Bulkhead Fitting
19	638007206-04	Nut, Bulkhead Fitting
20*	638007921	Connector, UL Ground
21*	638007295	Bulkhead Fitting, Water Cool
22*	638009711	Support, Condenser, Water Cooled
23*	638009712	Clip Condenser, Water Cooled
24*	638007208-03	Nut, Palnut, 3/4-16
25*	638090021	Valve, Water Regulating
26*	638036188	Receiver, Upright
27*	638036194	Valve, Head Pressure
28*	638037110	Washer, Seal
29*	638037111	Valve, Rotolock
30*	638036014	Cover, Electrical Box

Note: * = Not Shown

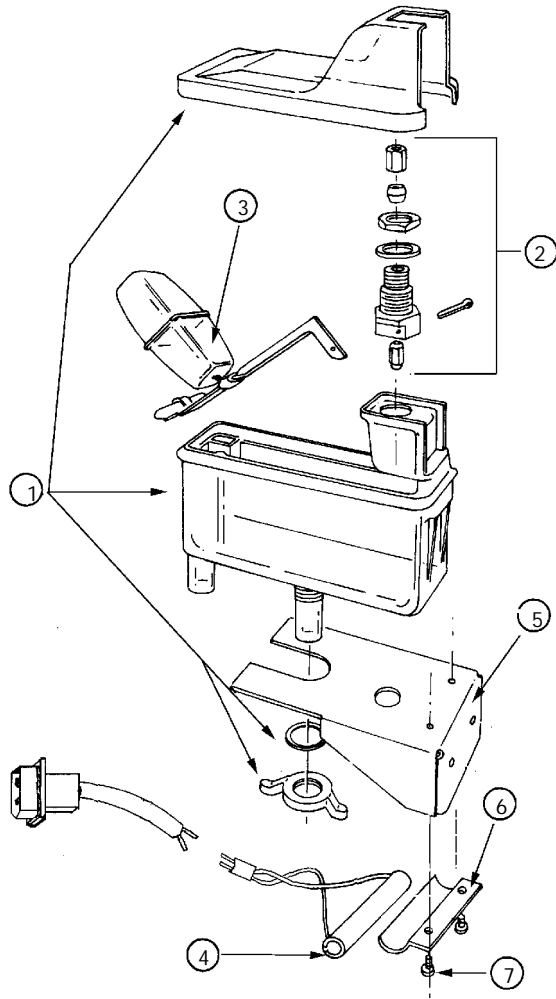

FIGURE 27. WATER LEVEL CONTROL ASSEMBLY MODEL WCC500/700/1000 SERIES
EXPLODED VIEW AND PARTS LIST

ITEM NO	PART NO	NAME
1	638030822	Reservoir Assembly WCC500/700
		Reservoir
		Cover
		O-Ring
		Wing Nut
1	638090348	Reservoir WCC1000/2000
	638090346	Reservoir Outlet WCC1000/2000
	638047005	Gasket WCC1000/2000
	638007217	Nut 1-14 WCC1000/2000
2	638030823	Hardware, Water Level Control
		Valve Body
		Cotter Pin
		Cap
		Spacer

ITEM NO	PART NO	NAME
		Plunger, Rubber
		Washer, Fiber
		Nut
		Sleeve
		Nut, Compression
3	63030819	Float and Stem Assembly
		Magnet & Bracket Assembly
		Float
4	638008483	Reed Switch Assembly WCC700/500
	638036069	Reed Switch Assembly WCC1000
	638092531	Reed Switch Assembly WCC2000
5	638004717	Bracket Water Level
	638090347	Bracket Water Level WCC1000
	638092529	Bracket Water Level WCC2000
6	638008097	Clamp, Reed Switch
7	638007002-01	Screw

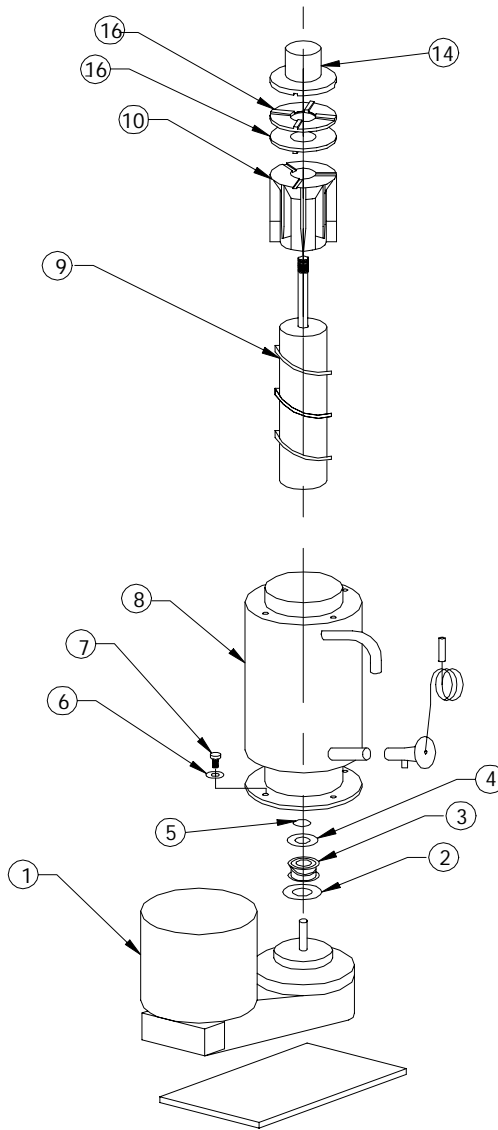

FIGURE 28. FRONT END ASSEMBLY MODEL 500 SERIES
EXPLODED VIEW AND PARTS LIST

Item No.	Part No.	Name
	638090130	Front End Assembly-WCC500
	638090130-002	Front End Assembly-WCC502
	638090143	Front End Assembly-WCF510
	638090143-002	Front End Assembly-WCF512
1	638090001-002	Gearmotor Less Cable, Seals O-ring seal-mount 220V 50 Hz
	638090050-002	Gearmotor-115V
	638090050-005	Gearmotor-220V 50Hz
2	638090116	Shaft Seal Seat
3	638090051	Shaft Seal
4	638007301-036	Washer, Lower
5	638090053	E-Ring

Item No.	Part No.	Name
6	638007302-06	Washer, Lock 1/4 Split
7	638007088-06	Screw, 1/4-20 x 3/4 Lg. HHMS
8	638036373-001	Evaporator Assembly
9	638090113	Auger
10	638090117	Extruding Head, WCC
11	638090118	Extruding Head, WCF
12	638090126	Expansion Valve
13	638036218	Bracket, Mounting Icemaker
14	638090111	Auger Nut
15	638090119	Bearing Nylon
16	638090120	Bearing Delrin

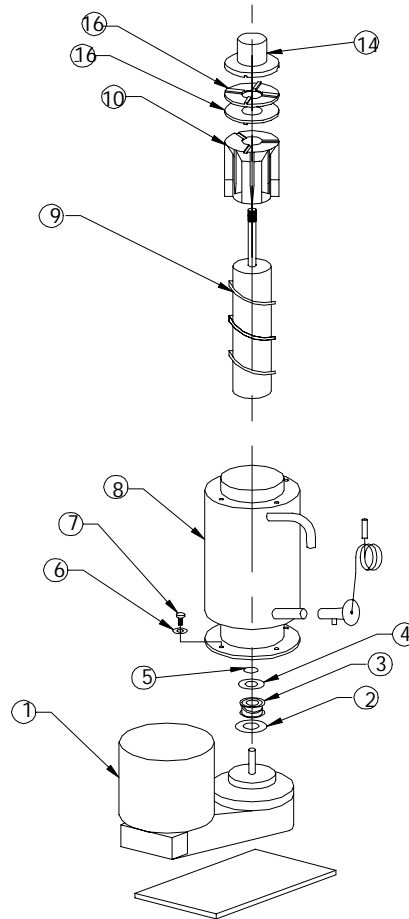

FIGURE 29. FRONT END ASSEMBLY MODEL 700 SERIES
EXPLODED VIEW AND PARTS LIST

Item No.	Part No.	Name
	638090230	Front End Assembly-WCC700
	638090230-001	Front End Assembly-WCC701
	638090230-002	Front End Assembly-WCC702
	638090227	Front End Assembly-WCF710
	638090227-001	Front End Assembly-WCF711
	638090227-002	Front End Assembly-WCF712
1	638090050	Gearmotor Assembly-700, 115V
	638090050-004	Gearmotor Assembly-208/230V 60Hz
	638090050-006	Gearmotor Assembly-220V 50Hz
	638090001	Gearmotor, 115V
	638090001-002	Gearmotor, 220V 50 Hz
	638090001-001	Gearmotor, 208/23-V 60Hz
2	638090215	Shaft Seal Mount
3	638090051	Shaft Seal

Item No.	Part No.	Name
4	638007301-030	Washer, Lower
5	638090053	E-Ring
6	638090216	Shaft Seal Seat
7	638007302-06	Washer, Lock 1/4 Split
8	638007088-06	Screw 1/4-20 x 3/4 Lg. HHMS
9	638036282-001	Evaporator Assembly
10	638090213	Auger
11	638090217	Extruding Head WCC
	638090218	Extruding Head WCF
12	638090226	Expansion Valve, Thermal
13	638036218	Bracket, Mounting
14	638090211	Auger Nut
15	638090219	Bearing Nylon
16	638090220	Bearing Delrin

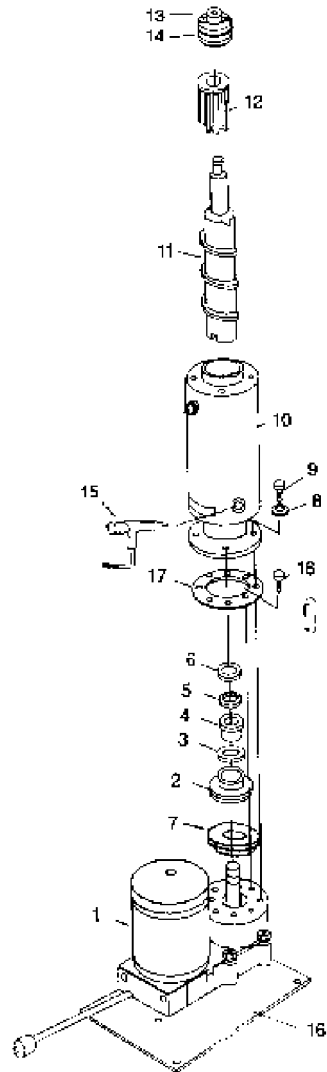

FIGURE 30. FRONT END ASSEMBLY MODEL 1000 & 2000 SERIES
EXPLODED VIEW AND PARTS LIST

Item No.	Part No.	Name
17	638090316	Shaft Seal Seat
	638090330-001	Front end Assy-WCC1001 & 2001
	638090330-002	Front end Assy-WCC1002 & 2002
	638090343-001	Front end Assy-WCF1101 & 2201
	638090343-002	Front end Assy-WCF1102 & 2202
1	638090000-001	Gearmotor-WCC1002 & 2002
	638090000-001	Gearmotor-WCC1001 & 2001
	638090050-001	Gearmotor Assy-WCC1001 & 2001
	638090050-001	Gearmotor Assy-WCC1002 & 2002
2	638090315	Shaft Seal Mount
3	638036042	O-Ring
4	638090051	Shaft Seal
5	638007301-030	Washer, Lower

Item No.	Part No.	Name
6	638090053	E-Ring
7	638007106-03	Screw 1/4 x 3/4 FHSC
8	638007302-06	Washer Lock 1/4 Split
9	638007088-01	Screw, 1/4-20 x 5/8 Lg. HHMS
10	638090335	Evaporator Assembly
11	638090313	Auger
12	638090317	Extruding Head Assembly Center
13	638090318	Extruding Head Flanker
14	638090311	Diverter Nut Assembly
15	638090319	Bearing Nylon
	638090320	Bearing Delrin
16	638090326	Expansion Valve, Thermal
17	638090349	Bracket, Mounting
18	638007106-03	Screw, 1/4 x 3/4 FHSC

Note: * = Not shown

638085278

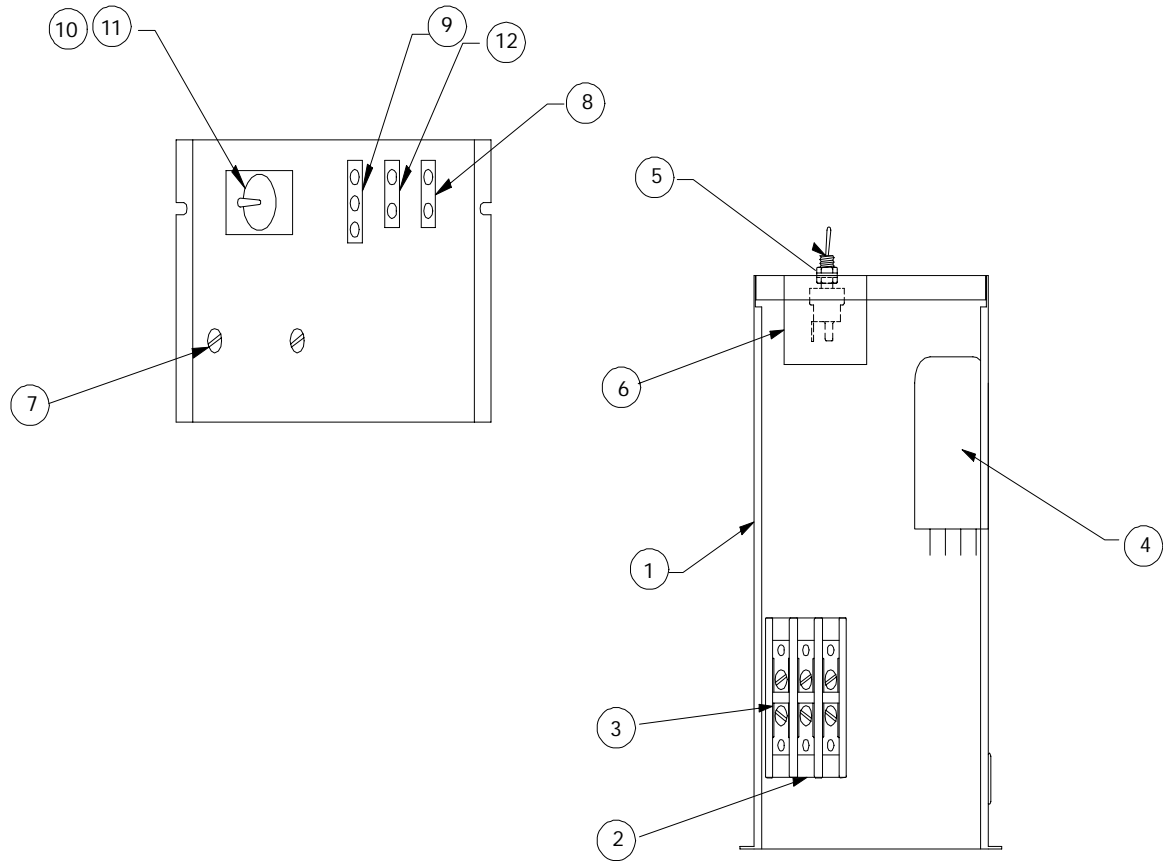

FIGURE 31. ELECTRICAL BOX ASSEMBLY MODEL 500 AND 700 SERIES

Item No.	Part No. 500/700 (115V)	Part No. 701 (208/230V)	Part No. 502/702 (220/240V)	Name	Qty.
1	638008816-01	638008816-01	638008816-01	Electrical box	1
2	638007026-03	638007026-03	638007026-03	Screw 8/32 x 5/8 RHMS	2
3	638090052	638090054	638090054	Contactora	1
4	638003898	638010002	638010002	Relay	1
5	638004791	638004791	638004791	Switch - Toggle	1
6	638036067	638036067	638036067	Bin Probe Assembly w/Holder, WCC	1
	638036085	638036085	638036085	Bin Probe Assembly w/Holder, WCF	1
7	638007026-01	638007026-01	638007026-01	Screw 8/32 x 3/8 RHMS	2
8	638007904-01	638007904-01	638007904-01	Housing 2 Pin Recept. Conn.	1
9	638007903-01	638007903-01	638007903-01	Housing 3 Pin Recept. Conn.	1
10	638004792	638004792	638004792	Indicator Plate	1
11	638007303-04	638007303-04	638007303-04	Lockwasher	1
12	638007904-01	638007904-01	638007904-01	Housing 2 Pin Recept. Conn. W/C	1
*	638036168	638036168	638036168	Bin Probe Holder, WCC	1
*	638036079	638036079	638036079	Bin Probe Holder, WCF	1
13*	638009387	638009387	638009387	Switch - Bin Control	1
*	638007341-03	638007341-03	638007341-03	Strain Relief	1
*	638007352-01	638007352-01	638007352-01	Bushing	1

NOTE: * = Not Shown

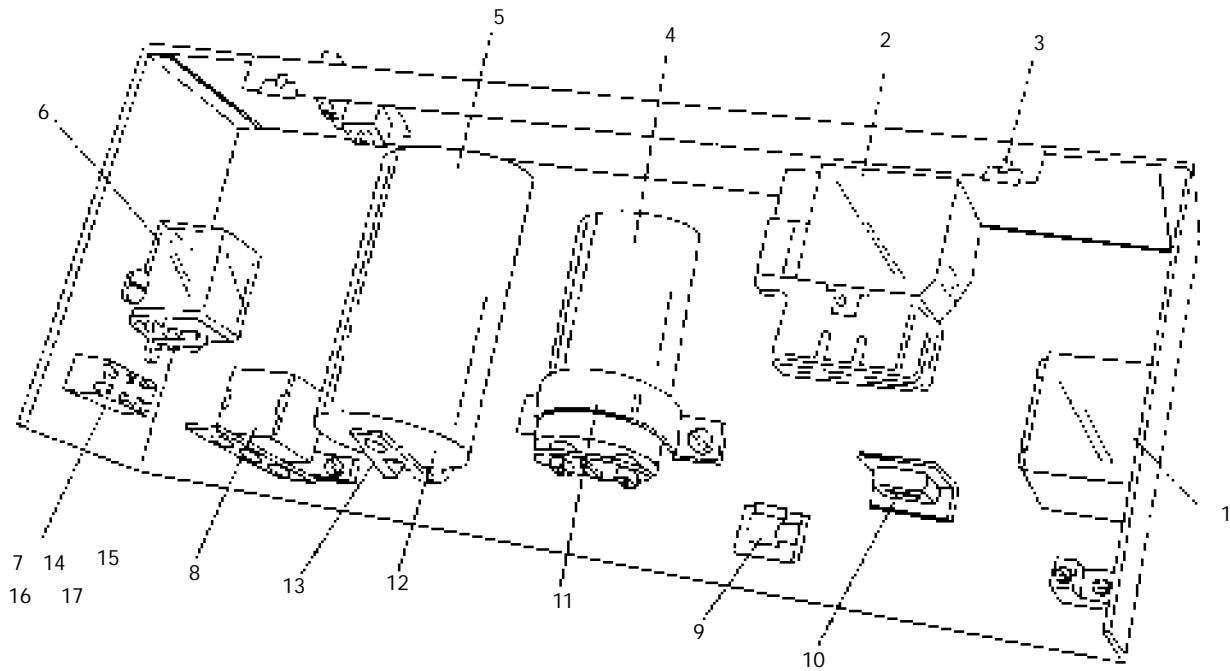

FIGURE 32. ELECTRICAL ASSEMBLY MODEL 1000 AND 2000 SERIES

Item No	Part No	Name
1	638090322	Start Relay, 208/230 60 Hz. WCC1001 and WCF1101
	638090242	Start Relay, 220V 50 Hz. WCC1002 and WCF1102
	40285	Start Relay, 208/230 60 Hz. WCC2001 and WCF2201
	161998013	Start Relay, 220 50 Hz. WCC2002 and WCF2202
2	638090054	Contactora, 208/230 50/60 Hz
3	63800726605	Nut, Tinnerman
4	638090323	Capacitor Run, 208/230 V 60 Hz. WCC1001 and WCF1101
	638090333	Capacitor Run, 220 V 50 Hz. WCC1002 and WCF1102
	161192005	Capacitor Run, 208/230 V 60 Hz. WCC2001 and WCF2201
	161192005	Capacitor Run, 220 V 50 Hz. WCC2002 and WCF2202
5	638090324	/Capacitor Start, 208/230 V 60 Hz. WCC1001 and WCF1101
	638090244	Capacitor Start, 220V 50 Hz WCC1002 and WCF1102
	41044	Capacitor Start, 208/230 V 60 Hz. WCC2001 and WCF2201
	161165013	Capacitor Start, 220 V 50 Hz. WCC2002 and WCF2202

Item No	Part No	Name
6	638010002	Relay
7	638004791	Switch Toggle/
8	638036067	Switch Assembly, Bin Control, WCC
		Switch Assembly, Bin Control, WCF
9	638004037	Cable Clip
10	63800734103	Strain Relief
11	638036038	Bracket, Run Capacitor WCC1000
12	638009757	Cap, Capacitor WCC1000
13	638009347	Bracket, Start Capacitor WCC1000
11 & 13	630200166	Capacitor Strap WCC2000
14	638004792	Indicator Plate, Toggle Switch
15	638007214	Nut-Hex 15/32
16	638007215	Nut-Face, 15/32
17	63800730304	Washer, Lock 15/32 Internal Tooth
18*	638009387	Switch - Bin Control

NOTE: * = Not Shown

IMI CORNELIUS WILSHIRE CERTIFICATE OF WARRANTY

TWO YEAR LIMITED ICE EQUIPMENT WARRANTY

IMI Cornelius Wilshire (formerly Wilshire Corp., Selmix Reynolds Products, Alco Dispensing Canada Ltd.) warranty to the original commercial purchaser/user, that any commercial product of its manufacture bearing the name Cornelius Wilshire will be free from defect in material and/or factory workmanship, and that if properly installed, maintained, and serviced in accordance with the *Service Manual* furnished with the product, it will perform adequately under normal use. This product warranty shall be effective for a period of two years from the date of original installation of 27 months from the date of original shipment by IMI Cornelius Wilshire, whichever period elapses first, provided the warranty registration card is completed and returned to IMI Cornelius Wilshire within 30 days from the date of installation.

IMI Cornelius Wilshire obligation under this warranty is limited to the repair or replacement, including reasonable labor charges, of any part of parts which the purchaser/user returns to IMI Cornelius Wilshire's factory, transportation costs prepaid, and which IMI Cornelius Wilshire finds to be defective in workmanship and/or material within the warranty period. To be reimbursable under this warranty, labor charges must be submitted to IMI Cornelius Wilshire within 30 days from the date of service, must be performed by a qualified company acceptable to IMI Cornelius Wilshire, and must be for reasonable and customary straight time labor charges only. No travel time, mileage, or other charges in excess of straight time charges will be accepted. Any replacement parts must be approved IMI Cornelius Wilshire parts. The serial and model numbers and date of original installation of the product must be given.

ADDITIONAL THREE YEAR LIMITED WARRANTY ON COMPRESSOR

The hermetically sealed refrigeration compressor is covered by the above two year limited warranty. In addition to that warranty, if the compressor fails because of a defect in materials or workmanship during the third through fifth year from the date of installation, IMI Cornelius Wilshire will repair or at its option, replace the compressor. Labor charges and the cost of relays, overloads and capacitors are not included.

This warranty does not include failure or other damage resulting from:

- S Electrical power failure to the ice machine for any reason
- S Water supply failure to the ice machine for any reason
- S Adverse operating conditions as set forth in your *Service Manual*
- S Drain line malfunctions as set forth in your *Service Manual*
- S Failure to clean and maintain the ice machine as set forth in your *Service Manual*
- S Use of non-authorized replacements parts
- S Unauthorized modification of the ice machine
- S Any product installed outside the U.S.A. or Canada

No part or assembly which has been subject to accident, alteration or misuse or which is not installed, maintained, or serviced in accordance with the *Service Manual* furnished with the product, or which is from a machine on which the serial number has been altered or removed, shall be covered by this warranty.

THIS WARRANTY DOES NOT COVER DAMAGE CAUSED BY LACK OF PREVENTATIVE MAINTENANCE, IMPROPER INSTALLATION, ACCIDENT, MISUSE, NEGLIGENCE, ALTERATION, FIRE, FLOOD, OR ACTS OF GOD. In those jurisdictions where liability for damages cannot be disclaimed, original purchaser's recovery shall not exceed the cost of the warranted product.

IMI CORNELIUS WILSHIRE ASSUMES NO LIABILITY FOR INCIDENTAL OR CONSEQUENTIAL DAMAGES OF ANY KIND, INCLUDING, BUT NOT LIMITED TO, SPOILED PRODUCT, LOST PROFITS, OR DAMAGE TO OTHER PROPERTY.

THIS WARRANTY IS EXCLUSIVE AND IN LIEU OF ALL OTHER WARRANTIES, WHETHER WRITTEN, ORAL, OR IMPLIED, INCLUDING ANY WARRANTY OF MERCHANTABILITY OR FITNESS FOR A PARTICULAR PURPOSE, AND SUPERSEDES AND EXCLUDES ANY ORAL WARRANTIES OR REPRESENTATIONS OR WRITTEN LANGUAGE IN ANY MANUAL, LITERATURE, ADVERTISING BROCHURE OR OTHER MATERIALS NOT EXPRESSLY DESIGNATED IN WRITING AS A "WARRANTY"

IMI CORNELIUS WILSHIRE

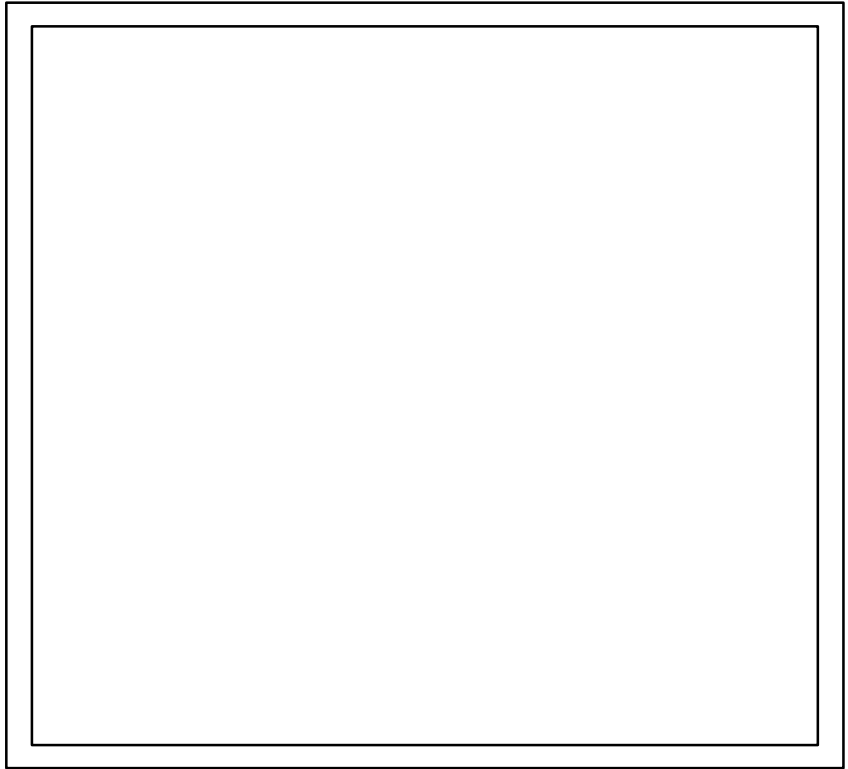

IMI CORNELIUS INC.

Corporate Headquarters:

One Cornelius Place
Anoka, Minnesota 55303-6234
Telephone (800) 238-3600
Facsimile (763) 422-3246