

DESA™

HEARTH PRODUCTS

VENTED DECORATIVE NATURAL GAS LOGS OWNER'S OPERATION AND INSTALLATION MANUAL

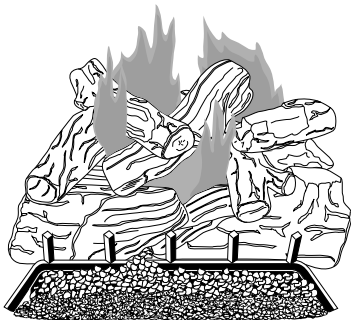

ANSI Z21.84
O-TL REPORT
114-L-31-4



COMFORT GLOW LOG SET AND BURNER MODELS CVSR18, CVSR24, CPVSR18, CPVSR24, CVDR18 CVDR24, CVDR30, BFLT18 AND BFLT24

⚠ WARNING: If the information in these instructions is not followed exactly, a fire or explosion may result causing property damage, personal injury or death.

FOR YOUR SAFETY

- Do not store or use gasoline or any other flammable vapors or liquids in the vicinity of this or any other appliance.
- **WHAT TO DO IF YOU SMELL GAS :**
 - Do not try to light any appliance.
 - Do not touch any electrical switch;
 - Do not use any phone in your building.
 - Immediately call your gas supplier from a neighbor's phone. Follow the gas supplier's instructions.
 - If you cannot reach your gas supplier, call the fire department.
- Installation and service must be performed by a qualified installer, service agency or the gas supplier.

INSTALLER: Leave this manual with the appliance.
CONSUMER: Retain this manual for future reference.

TABLE OF CONTENTS

Safety	2	Troubleshooting	16
Local Codes.....	4	Service Hints	19
Unpacking.....	4	Technical Service.....	19
Product Identification	5	Replacement Parts.....	19
Optional Product Features.....	5	Parts	20
Installation	5	Accessories	26
Operation.....	14	Warranty.....	Back Cover
Cleaning and Maintenance.....	15		

SAFETY

⚠ WARNING: Improper installation, adjustment, alteration, service or maintenance can cause injury or property damage. Refer to this manual for correct installation and operational procedures. For assistance or additional information consult a qualified installer, service agency or the gas supplier.

⚠ WARNING: This is a gas-fired appliance. It uses air (oxygen) from the room in which it is installed. Provisions for adequate combustion and ventilation air must be provided. Refer to the *National Fuel Gas Codes, ANSI Z233.1/NFPA 54, Air for Combustion and Ventilation.*

⚠ WARNING: This appliance is for installation only in a solid-fuel burning masonry or UL127 factory-built fireplace, constructed of noncombustible material, and connected to a working flue. (See page 6 for minimum flue opening.)

This appliance may be installed in an aftermarket*, permanently located, manufactured (mobile) home, where not prohibited by state or local codes.

State of Massachusetts: The installation must be made by a licensed plumber or gas fitter in the Commonwealth of Massachusetts.

⚠ WARNING: This product contains and/or generates chemicals known to the State of California to cause cancer or birth defects or other reproductive harm.

⚠ WARNING: Keep flue open when operating unit.

IMPORTANT: Read this owner's manual carefully and completely before trying to assemble, operate or service this log set. Improper use of this log set can cause serious injury or death from burns, fire, explosion, electrical shock and carbon monoxide poisoning.

⚠ DANGER: Carbon monoxide poisoning may lead to death!

Carbon Monoxide Poisoning: Early signs of carbon monoxide poisoning resemble the flu, with headaches, dizziness or nausea. If you have these signs, the log set may not be working properly. **Get fresh air at once!** Have log set serviced. Some people are more affected by carbon monoxide than others. These include pregnant women, people with heart or lung disease or anemia, those under the influence of alcohol and those at high altitudes.

*Aftermarket: Completion of sale, not for purpose of resale, from the manufacturer.

SAFETY

Continued

Natural Gas: Natural gas is odorless. An odor-making agent is added to the gas. The odor helps you detect a gas leak. However, the odor added to the gas can fade. Gas may be present even though no odor exists.

Make certain you read and understand all warnings. Keep this manual for reference. It is your guide to safe and proper operation of this log set.

 **WARNING:** Any change to this log set or its controls can be dangerous.

 **WARNING:** Do not use a blower insert, heat exchanger insert or other accessory not approved for use with this appliance.

 **WARNING:** This appliance is equipped for natural gas. An optional propane/LP conversion kit must be installed for use with propane/LP gas.

 **WARNING:** Do not allow fans to blow directly into the fireplace. Avoid any drafts that alter burner flame patterns.

 **WARNING:** Installed decorative glass door enclosures must be fully opened when operating this gas appliance.

Due to high temperatures, the appliance should be located out of traffic and away from furniture and draperies.

Do not place clothing or other flammable material on or near the appliance. Never place any objects on the appliance.

Appliance assembly becomes very hot when in use. Keep children and adults away from hot surface to avoid burns or clothing ignition. Appliance will remain hot for a time after shutdown. Allow surface to cool before touching.

Carefully supervise young children when they are in the room with appliance.

You must operate this appliance with a fireplace screen in place. Make sure fireplace screen is closed before running appliance.

Keep the appliance area clear and free from combustible materials, gasoline and other flammable vapors and liquids.

1. If you smell gas
 - shut off gas supply
 - do not try to light any appliance
 - do not touch any electrical switch; do not use any phone in your building
 - immediately call your gas supplier from a neighbor's phone. Follow the gas supplier's instructions
 - if you cannot reach your gas supplier, call the fire department
2. Never install the log set
 - in a recreational vehicle
 - where curtains, furniture, clothing, or other flammable objects are less than 42" from the front, top, or sides of the log set
 - in high traffic areas
 - in windy or drafty areas
3. Before installing in a solid fuel burning fireplace, the chimney flue and firebox must be cleaned of soot, creosote, ashes and loose paint by a qualified chimney cleaner. Creosote will ignite if highly heated. Inspect chimney flue for damage. If damaged, repair flue before operating appliance.

SAFETY

Continued

4. This log set is designed to be smokeless. If logs ever appear to smoke, turn off appliance and call a qualified service person.
Note: During initial operation, slight smoking could occur due to log curing and the burning of manufacturing residues. You may wish to add more ventilation by opening a window.
5. To reduce the creation of soot, follow the instructions in Cleaning and Maintenance, page 15.
6. The installation and provisions for combustion and ventilation air must conform with the *National Fuel Gas Code, ANSI Z223.1/NFPA 54, Air for Combustion and Ventilation*.
7. Do not run log set
 - where flammable liquids or vapors are used or stored
 - under dusty conditions
8. Do not burn solid fuel in the fireplace after installing the log set. Do not use this log set to cook food or burn paper or other objects.
9. Do not use appliance if any part has been exposed to or under water. Immediately call a qualified service technician to inspect the room appliance and to replace any part of the control system (if using GA9050A-1 or GA9150A) and any gas control which has been under water.
10. To help prevent breakage, new logs must be broken-in (see Curing Logs page 14).
11. Turn log set off and let cool before servicing, installing, or repairing. Only a qualified service person should install, service, or repair log set.
12. Provide adequate clearances around air openings.
13. This vented gas log set may not be installed in a bedroom or bathroom in the Commonwealth of Massachusetts.

LOCAL CODES

Install and use log set with care. Follow all local codes. In the absence of local codes, use the latest edition of *The National Fuel Gas Code ANSI Z223.1/NFPA 54**.

*Available from:

American National Standards Institute, Inc.
1430 Broadway
New York, NY 10018
National Fire Protection Association, Inc.
Batterymarch Park
Quincy, MA 02269

UNPACKING

 **CAUTION: Do not remove the data plates from the burner pan. The data plates contain important product information.**

1. Remove logs, hearth kit, pan materials, and hardware from carton.
2. Remove all protective packaging applied to logs and base for shipment.
3. Check heater for any shipping damage. If heater is damaged call DESA Heating, LLC at 1-866-672-6040 for replacement parts before returning to dealer.

PRODUCT IDENTIFICATION

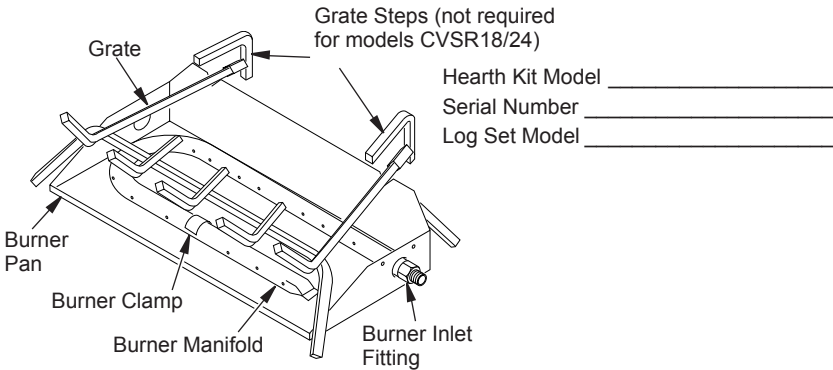

Figure 1 - Product Identification (Dual Burner Shown)

OPTIONAL PRODUCT FEATURES

ON/OFF SAFETY VALVE/PILOT KIT AND PROPANE/LP CONVERSION

An optional valve/safety pilot kit with a piezo ignitor is available for this appliance. This system requires no matches, batteries, or other sources to light. You must use this optional system for LP conversion. See [Accessories](#), page 26.

REMOTE CONTROL READY (MILLIVOLT) SAFETY VALVE/PILOT KIT

An optional millivolt valve/safety pilot kit with a piezo ignitor is available for this appliance. This system requires no matches, batteries,

or other sources to light. This system may be connected to a wall switch or hand-held wireless remote control. See [Accessories](#), page 26.

REMOTE CONTROL ACCESSORIES

There is an optional hand-held ON/OFF remote control that can be purchased separately for this log set. You must use the millivolt valve/safety pilot kit to use remote accessories with this appliance. See [Accessories](#), page 26.

A wall switch is also available for this appliance. You must use the millivolt valve/safety pilot kit to use the wall switch with this appliance. See [Accessories](#), page 26.

INSTALLATION

CAUTION: Do not remove the data plates attached to the burner pan. The data plates contain important warranty and safety information.

WARNING: Before installing in a solid fuel burning fireplace, the chimney flue and firebox must be cleaned of soot, creosote, ashes and loose paint by a qualified chimney cleaner. Creosote will ignite if highly heated. A dirty chimney flue may create and distribute soot within the house. Inspect chimney flue for damage. If damaged, repair flue before operating heater.

INSTALLATION

Continued

NOTICE: Installation, service, and repair of this appliance must be performed by a qualified installer, service agency, company or gas supplier experienced with this type of gas appliance. Only factory authorized components listed in these instructions may be used in accordance with the manufacturer's instructions and all codes and requirements of the authority having jurisdiction. Any modifications to this kit, or use of unauthorized components or accessory items will void the manufacturer's warranty, and may result in a hazardous condition.

FLUE OPENING SPECIFICATIONS

Note: This vented appliance must be installed only in a solid-fuel burning fireplace with a working flue and constructed of noncombustible material.

The charts in Figure 2, indicate technical information regarding the installation of your gas log set. Please make sure that all of the specifications shown are applicable before installation is attempted.

The fireplace must include a working flue and venting system with the minimum openings shown in the Figure 2.

Model	Burner Description	Btu/Hr Input Natural Gas	Btu/Hr Input Propane/LP Gas	Minimum Vent Opening
CPVSR18 CVSR18	18" Single	50,000	40,000	8" dia.
CPVSR24 CVSR24	24" Single	60,000	50,000	8" dia.
CVDR18	18" Dual	55,000	45,000	8" dia.
CVDR18 CVDR24	24" Dual	65,000	55,000	8" dia.
CVDR24	30" Dual	70,000	60,000	8" dia.
BFLT18	18" Triple	65,000	55,000	8" dia.
BFLT24	24" Triple	70,000	60,000	8" dia.

MINIMUM FIREBOX SIZES			
Models: CPVSR18, CVSR18, CVDR18			
Front Width*	Back Width**	Depth	Height
28"	16"	14"	18"
Models: CPVSR24, CVSR24, CVDR24			
Front Width*	Back Width**	Depth	Height
29 3/4"	17"	15 1/2"	18"
Model: CVDR30			
Front Width*	Back Width**	Depth	Height
36"	27"	18"	18"
Model: BFLT18			
Front Width*	Back Width**	Depth	Height
28"	16"	15 1/2"	18"
Model: BFLT24			
Front Width*	Back Width**	Depth	Height
30"	22"	15 1/2"	18"

*Add 6" if safety valve/pilot is used

**At depth indicated

FUEL INLET PRESSURE SPECIFICATIONS (W.C.)		
	Min.	Max.
NG	5.5"	10.5"
LP	11"	13"

BURNER ORIFICE				
LOG SIZE	NATURAL		PROPANE/LP	
	IN.	NUM.	IN.	NUM.
CVSR18, CPVSR18 CVDR18	0.120	31	0.073	49
CVSR24, CPVSR24 CVDR24, BFLT18	0.129	30	0.086	44
CVDR30, BFLT24	0.1405	28	0.089	43

Figure 2 - Technical Information Charts

INSTALLATION

Continued

CHECK GAS TYPE

Use only natural gas. If your gas supply is not natural gas, you must install ON/OFF Safety Valve/Pilot Kit (see *Accessories*, page 26). Call dealer where you bought log set.

If the fireplace does not have a gas supply shutoff valve, one must be installed.

VENTING SPECIFICATIONS FOR INSTALLATION

The fireplace chimney flue and vent must be drafting properly. To check the vent for proper drafting: Light a tightly rolled newspaper on one end and place it at the inside front edge of the fireplace. Observe the smoke and be sure the vent is properly drawing it up the chimney. If the smoke spills out into the room, extinguish the flame and remove any obstruction until proper venting is achieved.

The chimney flue must remain open a minimum of 3" at all times during the operation of this log set.

For Massachusetts Residents Only

Installation of this vented gas log set in the Commonwealth of Massachusetts requires the damper be permanently removed or welded in the fully open position.

INSTALLING DAMPER CLAMP

Secure the damper stop clamp provided to the leading edge of the damper as shown in Figure 3. If for any reason this clamp doesn't work on your fireplace, another suitable clamp or permanent stop must be installed, or the damper blade must be cut or removed.

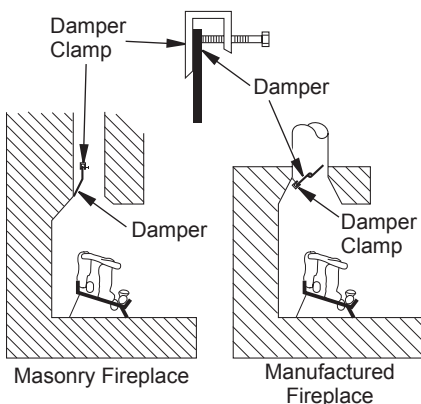

Figure 3 - Attaching Damper Clamp

CONNECTING TO GAS SUPPLY

⚠ WARNING: A qualified service person must connect log set to gas supply. Follow all local codes.

Installation Items Needed

Before installing log set, make sure you have the items listed below.

- piping (check local codes)
- sealant (resistant to Propane/LP gas)
- equipment shutoff valve
- test gauge connection
- adjustable (crescent) wrench or pliers
- sediment trap
- tee joint
- pipe wrench

⚠ CAUTION: Use only new, black iron or steel pipe. Internally-tinned copper tubing may be used in certain areas. Check your local codes. Use pipe of 1/2" diameter or greater to allow proper gas volume to log set. If pipe is too small, undue loss of volume will occur.

Installation must include a equipment shutoff valve, union, and plugged 1/8" NPT tap. Locate NPT tap within reach for test gauge hook up. NPT tap must be upstream from log set (see Figure 4, page 8).

IMPORTANT: Install equipment shutoff valve in an accessible location. The equipment shutoff valve is for turning on or shutting off the gas to the appliance.

Apply pipe joint sealant lightly to male NPT threads. This will prevent excess sealant from going into pipe. Excess sealant in pipe could result in a clogged burner injector.

⚠ WARNING: Use pipe joint sealant that is resistant to liquid petroleum (LP) gas.

INSTALLATION

Continued

We recommend that you install a sediment trap in supply line as shown in Figure 4. Locate sediment trap where it is within reach for cleaning. Install in piping system between fuel supply and heater. Locate sediment trap where trapped matter is not likely to freeze. A sediment trap traps moisture and contaminants. This keeps them from going into log set controls. If sediment trap is not installed or is installed wrong, log set may not run properly.

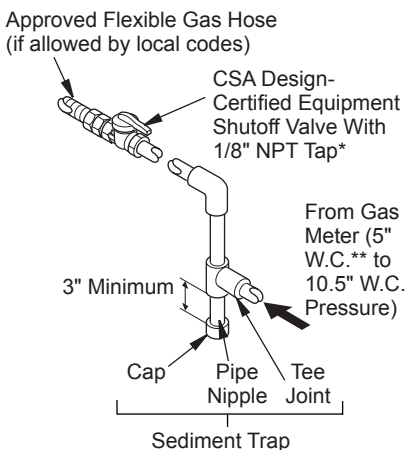

Figure 4 - Gas Connection

* Purchase the optional CSA design-certified equipment shutoff valve from your dealer.

** Minimum inlet pressure for purpose of input adjustment.

CHECKING GAS CONNECTIONS

WARNING: Test all gas piping and connections, internal and external to unit, for leaks after installing or servicing. Correct all leaks at once.

WARNING: Never use an open flame to check for a leak. Apply a noncorrosive leak detection fluid to all joints. Bubbles forming show a leak. Correct all leaks at once.

PRESSURE TESTING GAS SUPPLY PIPING SYSTEM

Test Pressures In Excess Of 1/2 PSIG (3.5 kPa)

1. Disconnect log set and its individual equipment shutoff valve from gas supply piping system.
2. Cap off open end of gas pipe where equipment shutoff valve was connected.
3. Pressurize supply piping system by either using compressed air or opening main gas valve located on or near gas meter.
4. Check all joints of gas supply piping system. Apply noncorrosive leak detection fluid to gas joints. Bubbles forming show a leak.
5. Correct all leaks at once.
6. Reconnect log set and equipment shutoff valve to gas supply. Check reconnected fittings for leaks.

Test Pressures Equal To or Less Than 1/2 PSIG (3.5 kPa)

1. Close equipment shutoff valve (see Figure 5).
2. Pressurize supply piping system by either using compressed air or opening main gas valve located on or near gas meter.
3. Check all joints from gas meter to equipment shutoff valve (see Figure 5). Apply noncorrosive leak detection fluid to gas joints. Bubbles forming show a leak.
4. Correct all leaks at once.

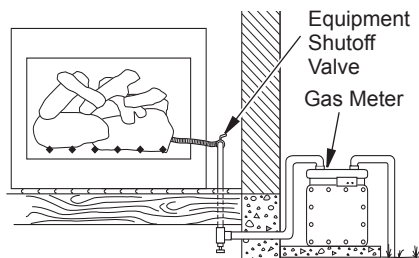

Figure 5 - Checking Gas Joints

INSTALLATION

Continued

HEARTH KIT ASSEMBLY AND INSTALLATION

Kit Assembly - Single and Dual-Flame Only

1. Determine which side gas line will be coming into fireplace.

NOTICE: Triple-burner models BFLT18 and BFLT24 come preassembled with gas inlet on right side of burner pan. DO NOT attempt to reposition burner on triple-burner models. If your fireplace supply is on the left side, a longer 3/8" flex line should be purchased and routed behind burner pan and away from flame area.

2. Using a hammer and screw driver, remove knockout plug from side of pan that corresponds to gas line (see Figure 6).
3. Unscrew burner inlet fitting from burner manifold.
4. Place burner manifold in pan with threaded opening facing open knockout plug.
5. Using thread sealant (resistant to the action of propane/LP gas) on larger end of fitting, screw burner inlet fitting through hole and into burner manifold (see Figure 6). Tighten using a wrench. If using propane/LP gas, see [Propane/LP Gas Conversion](#), page 11.
6. Using burner clamp, screw, and nut provided, assemble clamp to pan ("U" style and triple burners only). This will hold burner manifold in place.
7. If using optional GA9050A-1 kit, go to [Optional GA9050A-1 On/Off Safety Valve/Pilot Kit](#), page 10, for installation instructions. If using optional GA9150A kit, follow instructions included with kit for installation and operation.

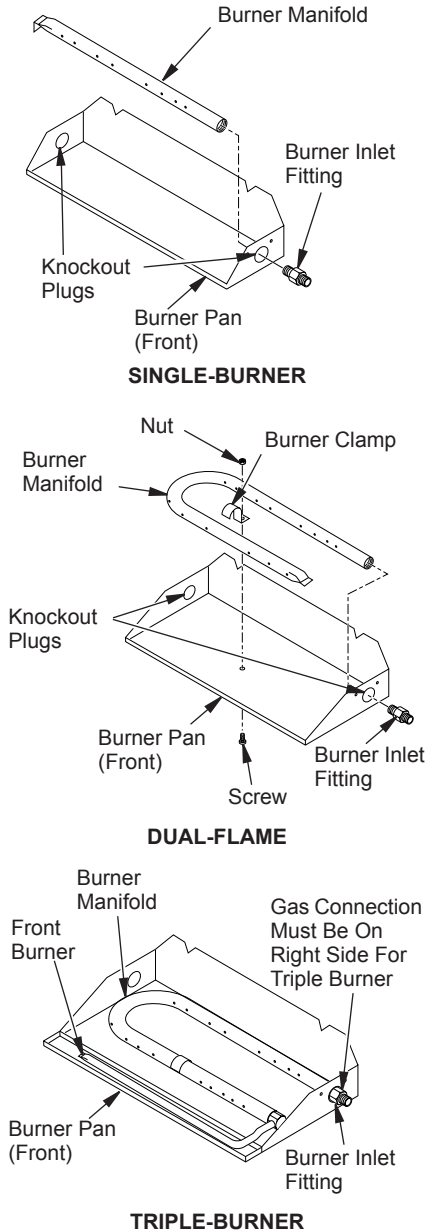

Figure 6 - Installing Burner

INSTALLATION

Continued

Installation and Gas Connection

1. Place burner pan assembly in center of fireplace floor. Make sure front of pan faces forward.
2. Thread gas supply fitting to fireplace gas supply pipe. Use thread sealant.
3. Install adapter fitting onto burner inlet fitting using thread sealant on male threads of burner inlet fitting (see Figure 7). Adjust to most convenient position.
4. Install gas connector tube to gas supply fitting. Carefully shape tube to attach to adapter fitting. Be careful not to cause kinks in tube.

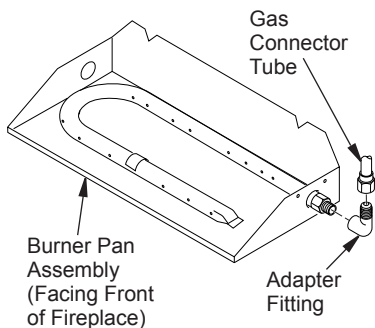

Figure 7 - Connecting Gas to Appliance

OPTIONAL GA9050A-1 ON/OFF SAFETY VALVE/PILOT KIT ASSEMBLY

For additional convenience and safety, or for propane/LP conversion, an optional ON/OFF safety valve/pilot kit is available. See [Accessories](#), page 26.

WARNING: You must use a ON/OFF safety valve/pilot kit for propane/LP conversion.

Natural Gas Installation

1. Thread gas control valve onto burner inlet fitting (see Figure 8). Use thread sealant on male threads of burner inlet fitting. Hold burner inlet fitting with a wrench to prevent overtightening connection to the burner. Make sure control rod is facing the front (see Figure 8).

2. Attach pilot gas line to pilot outlet of gas control valve and tighten. Connect thermocouple to rear of gas control valve. See Figure 9. Do not overtighten. If using propane/LP gas, see [Changing Pilot Orifice](#), page 12.
3. Install inlet fitting into inlet opening of gas control valve (see Figure 10). Use thread sealant on male pipe threads.
4. Place burner pan assembly in center of fireplace floor. Make sure front of pan faces forward.
5. Thread gas supply fitting to fireplace gas supply pipe. Adjust to most convenient position.

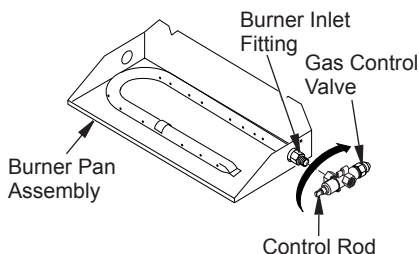

Figure 8 - Installing Gas Control Valve

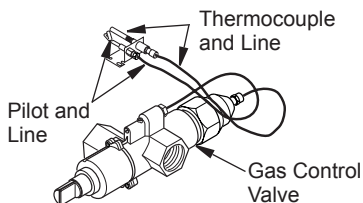

Figure 9 - Gas Control Valve with Thermocouple and Pilot

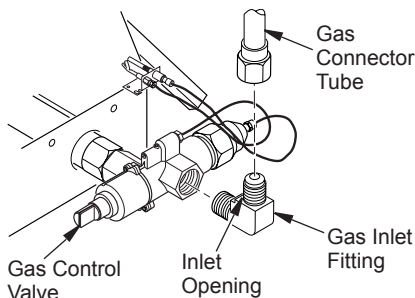

Figure 10 - Installing Inlet Fitting and Gas Connector Tube

INSTALLATION

Continued

6. Install gas connector tube to gas supply fitting. Carefully shape tube to attach to adapter fitting. Be careful not to cause kinks in tube.
7. Test for leaks following instructions under Testing Burner for Leaks, page 12.
8. Retighten and adjust location of gas control as necessary. Gas control should be level, with control rod to front.
9. Install cover to burner pan using screws provided.
10. Install thermocouple, pilot, and ignitor onto valve cover as shown in Figure 11. Use provided screws.
11. Push control rod extension onto "D" shaped control rod through center hole in cover.
12. Install position decal and control knob making sure to align marks with correct stop positions of gas control. Pilot position will allow knob to push in about 1/2". Align decals in pilot position.

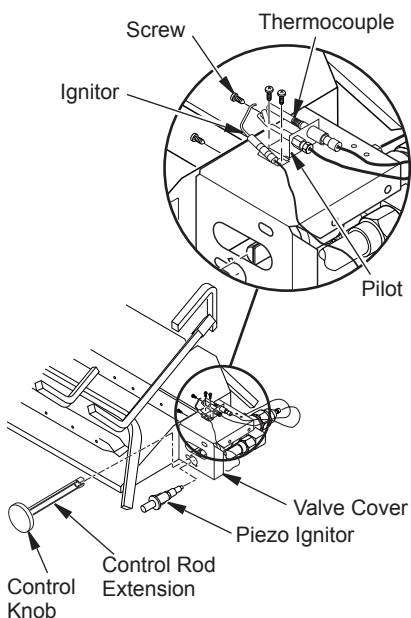

Figure 11 - Installing Cover, Control Knob, and Piezo Ignitor

PROPANE/LP GAS CONVERSION

To convert to propane/LP gas, burner inlet fitting and pilot orifice must be replaced. Propane/LP burner inlet fitting is supplied with orifice installed for a 24" log set. If you have an 18" or 30" set, you must change this orifice also. See Figure 1, page 5 for product identification.

Burner Inlet Fitting

1. Remove burner inlet fitting from burner pan assembly. DO NOT remove orifice from this fitting. Propane/LP burner inlet fitting is included in hardware kit (see Figure 12).
2. Be sure to use correct orifice for your appliance. The hardware kit included with this appliance contains two orifices with a cone-like shape. If you have an 18" set, orifice for burner inlet fitting is red; for a 30" set, it is black. If you have a 24" log set, orifice is already installed inside fitting.
3. For an 18" or 30" set, use a 10 mm socket or nut driver to remove orifice from propane/LP burner inlet fitting. Choose the correct orifice for your log set size and install in place of orifice you just removed.
4. Using thread sealant (resistant to the action of propane/LP gas) on larger end of fitting, screw burner inlet fitting through hole and into burner manifold (see Figure 13). Tighten using a wrench.
5. Follow steps 1 through 12 under Natural Gas Installation, page 10.

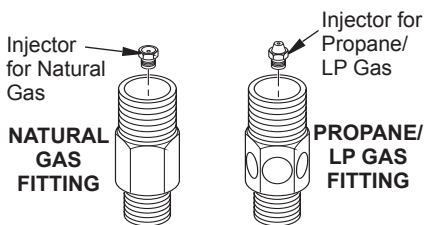

Figure 12 - Burner Inlet Fittings with Injectors

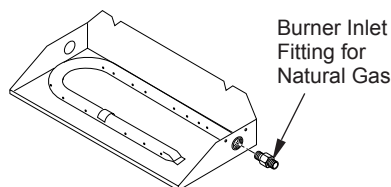

Figure 13 - Remove Burner Inlet Fitting

INSTALLATION

Continued

Changing Pilot Orifice

The pilot is provided with a natural gas orifice installed. For propane/LP gas you must remove it and replace it with an propane/LP orifice. The accessory hardware kit contains an propane/LP orifice with a red stripe for converting pilot.

1. Gently loosen and remove pilot line connection from bracket (see Figure 14).
2. Replace injector (see Figure 14) with propane/LP pilot injector with red stripe.
3. Replace and tighten pilot line to bracket.
4. Continue with step 3 under *Natural Gas Installation*, page 10.

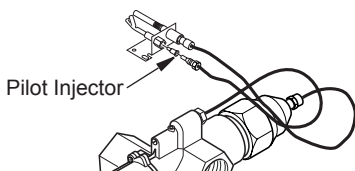

Figure 14 - Installing Propane/LP Pilot Orifice

TESTING BURNER FOR LEAKS

1. Generously apply noncorrosive leak detection fluid to all connections.

⚠ WARNING: Never check for gas leaks with open flame.

2. Light burner with shutoff valve no more than half open and holding a match slightly in front of pan (see *Lighting Instructions*, page 14).
3. Inspect all connections for bubbles, raw gas odor, or flame from any area other than burner (leaks). If leaks are detected, shut off gas valve immediately. Tighten, or reassemble loose connection(s) using pipe joint compound until burner system is leak free.
4. When burner is tested and leak free, observe individual tongues of flame on burner.

Note: Burner design includes more ports on the outside of the bar. Make sure that all ports are clear and producing flame evenly across burner. If any ports appear blocked, clear them by removing burner manifold and reaming ports with a modified paper clip or other suitable tool.

5. When finished testing, turn gas shutoff valve OFF to extinguish all flames.

ADDING PAN MATERIAL

1. Open bag of ash bed material (vermiculite) and spread it evenly across burner pan to top. You may overflow front and sides of pan to cover entire pan and connecting hardware. Do not cover GA9050A-1 or GA9150A valve.
2. Open glowing embers and evenly cover ash bed material (vermiculite) in burner pan.

INSTALLING GRATE AND LOGS

1. Place grate over burner pan where two outer horizontal supports on grate fit into two pan positioning notches in rear vertical edge of pan.
2. Slide two rear log grate steps over two outer horizontal supports on grate as shown in Figure 15. (Not required for models CVSR18/24.)
3. Place back log on grate onto grate steps (see Figure 16, page 13).
4. Place front log(s) on grate and slide forward against front bars on grate (see Figure 16, page 13).

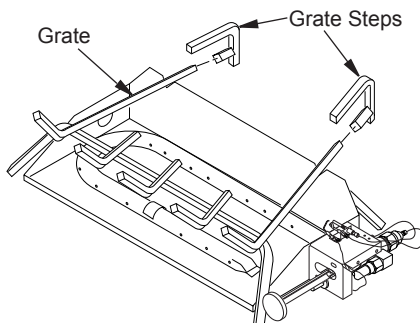

Figure 15 - Installing Grate (Pan Material Not Shown)

INSTALLATION

Continued

5. Place smaller top logs onto bottom logs (see Figure 17). Leave as much open space between logs as possible to minimize flame impingement and sooting.

Note: Logs may chip if they are handled roughly or if hit together while being placed.

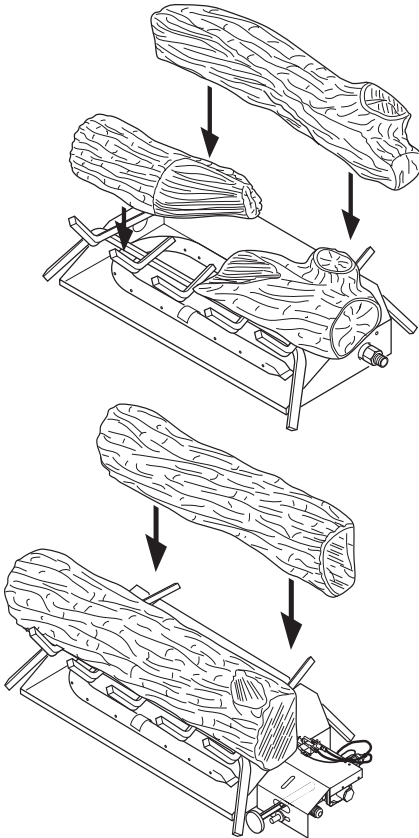

Figure 16 - Installing Front and Back Logs (Number and style may vary)

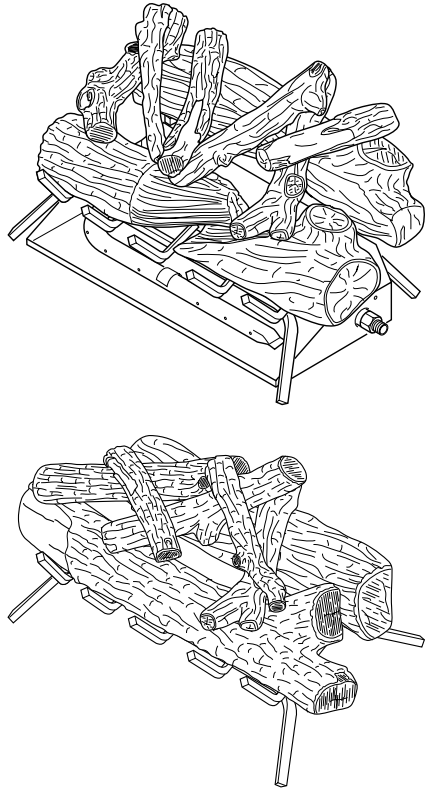

Figure 17 - Placement of Top Logs

OPERATION

FOR YOUR SAFETY READ BEFORE LIGHTING

WARNING: Keep flue open when operating unit.

WARNING: If you do not follow these instructions exactly, a fire or explosion may result causing property damage, personal injury or loss of life.

BEFORE LIGHTING smell all around the appliance area for gas. Be sure to smell next to the floor because some gas is heavier than air and will settle on the floor.

WHAT TO DO IF YOU SMELL GAS



- Do not try to light any appliance.
- Do not touch any electric switch; do not use any phone in your building.
- Immediately call your gas supplier from a neighbor's phone. Follow the gas supplier's instructions.
- If you cannot reach your gas supplier, call the fire department.

LIGHTING INSTRUCTIONS

1. STOP! Read the safety information, above.
2. Turn gas shutoff valve to OFF.
3. Wait five (5) minutes to clear out any gas. If you then smell gas STOP! Follow the safety information, above. If you don't smell gas, go on to the next step.
4. Light a match and lay it on top of pan material about 2" from end of supply side of pan
5. Slowly turn gas shutoff valve ON until burner ignites. If burner doesn't ignite within 10 seconds with match burning, turn shutoff valve OFF and repeat steps 1 through 4 again.

GAS SHUTOFF VALVE OPERATION

Flame Adjustment

Adjust the flame ON/OFF by turning gas shutoff valve counterclockwise  to open or clockwise  to close, as necessary.

Shutting Off Appliance

Turn gas shutoff valve clockwise  to OFF position.

CURING LOGS



During the 2-3 hour appliance break-in period, you may detect an odor from the appliance as various paints and compounds used in manufacturing of this log set cure. This is a normal and temporary situation that is not cause for alarm. However, you may want to provide extra ventilation to the room during this time.

To ensure proper curing of the logs:

- Ignite a 2" flame and maintain it for 1 hour.
- Burn logs in consecutive 1 hour periods raising the flame an additional 2" to full flame height for a total of three hours.

OPERATING INSTRUCTIONS FOR GA9050A-1

Note: Operation instructions for GA9050A-1 Remote Ready Valve/Pilot Kit will be included with the kit.

1. STOP! Read the safety information, column 1.
2. Make sure equipment shutoff valve is fully open.
3. Press in and turn control knob clockwise  to the OFF position.
4. Wait five (5) minutes to clear out any gas. Then smell for gas around log set and near floor. If you smell gas, STOP! Refer to the *National Fuel Gas Codes, ANSI Z233.1/NFPA 54, Air for Combustion and Ventilation*. If you don't smell gas, go to the next step.
5. Turn control knob counterclockwise  to the PILOT position and press in. Keep control knob pressed in for five (5) seconds.

OPERATION

Continued

Note: You may be running this log set for the first time after hooking up to gas supply. If so, the control knob may need to be pressed in for 30 seconds. This will allow air to bleed from the gas system.

- If control knob does not pop up when released, contact a qualified service person or gas supplier for repairs.

6. With control knob pressed in, push down and release ignitor button. This will light pilot. The pilot is attached to the rear of the front burner. If needed, keep pressing ignitor button until pilot lights.

Note: If pilot does not stay lit, contact a qualified service person or gas supplier for repairs. Until repairs are made, light pilot with match.

7. Keep control knob pressed in for 30 seconds after lighting pilot. After 30 seconds, release control knob.

Note: If pilot goes out, repeat steps 3 through 7, page 14.

8. Turn control knob counterclockwise ↺ to the ON position. Burner should light. If burner does not light, call a qualified service person.
9. To leave pilot lit and shut off burners only, turn control knob clockwise ↻ to the PILOT position.

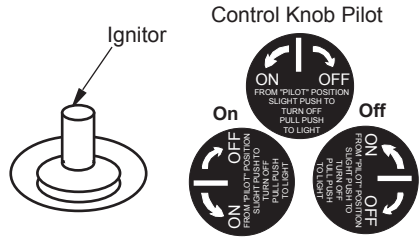

Figure 19 - Ignitor and Control Knob

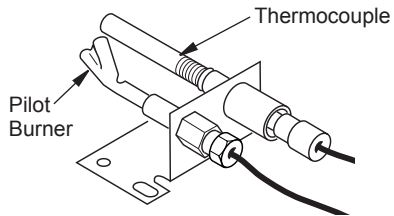

Figure 20 - Thermocouple and Pilot

TO TURN OFF GAS TO APPLIANCE

1. Turn control knob clockwise ↻ to the PILOT position.
2. Press in and turn control knob clockwise ↻ to the OFF position.
3. Close equipment shutoff valve.

CLEANING AND MAINTENANCE

- Keep the area around the log set clean and clear of debris.
- Occasionally, you may use a soft bristle brush to clean logs.
- Once every year a qualified agency or certified chimney sweep should examine and clean the venting system of the fireplace.

TROUBLESHOOTING



WARNING: Turn off log set and let cool before servicing. Only a qualified service person should service and repair log set.

Note: All troubleshooting items are listed in order of operation.

OBSERVED PROBLEM	POSSIBLE CAUSE	REMEDY
<p>Log set is smoking/sooting excessively <i>(Note: It is natural and unavoidable for vented gas log sets to produce moderate levels of carbon (soot) where flames contact the logs. This is especially true with propane/LP gas.)</i></p>	<ol style="list-style-type: none"> 1. Poor fuel quality 2. Fireplace venting system not drafting properly 3. Excessive flame impingement or blockage 4. Improper fuel/air mixture 5. Excessive gas supply/pressure 	<ol style="list-style-type: none"> 1. Contact local natural or propane/LP gas company 2. Adjust damper wide open and/or have fireplace and venting professionally cleaned and checked 3. Separate the logs to allow more flame passage 4. Remove any foreign items from the flame pattern and/or check for proper orifice sizing 5. Preheat flue in very cold weather
<p>Burner is excessively noisy <i>(Note: The movement and combustion of gas will create low, unavoidable levels of noise.)</i></p>	<ol style="list-style-type: none"> 1. Passage of air/gas across irregular surfaces 	<ol style="list-style-type: none"> 1. Relieve any tight bends or kinks in gas supply line
<p>Burner flame is too low or too high</p>	<ol style="list-style-type: none"> 1. Incorrect gas supply or pressure 2. Blocked burner orifice or burner manifold ports 3. Improper burner orifice size 	<ol style="list-style-type: none"> 1. Check for proper gas supply pressure 2. Free burner orifice and manifold ports of any burrs, paint, or other blockage 3. Verify proper burner orifice sizing (see Figure 2, page 6)
<p>When ignitor button is pressed, there is no spark at pilot (GA9050A-1 Only)</p>	<ol style="list-style-type: none"> 1. Ignitor electrode not connected to ignitor cable 2. Ignitor cable pinched or wet 3. Bad ground on piezo ignitor 4. Broken ignitor cable 5. Bad piezo ignitor 6. Ignitor electrode broken 7. Ignitor electrode positioned wrong 	<ol style="list-style-type: none"> 1. Reconnect ignitor cable 2. Free ignitor cable if pinched by any metal or tubing. Keep ignitor cable dry 3. Scrape away paint on bracket for better contact with ground on piezo ignitor 4. Replace ignitor cable 5. Replace piezo ignitor 6. Replace electrode 7. Reposition electrode

TROUBLESHOOTING

Continued

OBSERVED PROBLEM	POSSIBLE CAUSE	REMEDY
When ignitor button is pressed, there is spark at pilot but no ignition (GA9050A-1 Only)	<ol style="list-style-type: none"> 1. Gas supply turned off or equipment shutoff valve closed 2. Control knob not in PILOT position 3. Control knob not pressed in while in PILOT position 4. Air in gas lines when installed 5. Pilot adjustment screw closed 6. Pilot is clogged 7. Low gas pressure 	<ol style="list-style-type: none"> 1. Turn on gas supply or open equipment shutoff valve 2. Turn control knob to PILOT position 3. Press in control knob while in PILOT position 4. Continue holding down control knob. Repeat igniting operation until air is removed 5. Adjust pilot flame for approximately 2" blue flame 6. Clean pilot (see Cleaning and Maintenance, page 15) or replace pilot assembly 7. Replace gas control
Pilot lights but flame goes out when control knob is released (GA9050A-1 Only)	<ol style="list-style-type: none"> 1. Control knob not fully pressed in 2. Control knob not pressed in long enough 3. Equipment shutoff valve not fully open 4. Pilot flame not touching thermocouple, which allows thermocouple to cool, causing pilot flame to go out. This problem could be caused by one or both of the following: A) Low gas pressure B) Dirty or partially clogged pilot 5. Thermocouple connection loose at control valve 6. Thermocouple damaged 7. Control valve damaged 	<ol style="list-style-type: none"> 1. Press in control knob fully 2. After pilot lights, keep control knob pressed in 30 seconds 3. Fully open equipment shutoff valve 4. A) Contact local natural gas company B) Clean pilot (see Cleaning and Maintenance, page 15) or replace pilot assembly 5. Hand tighten until snug, then tighten 1/4 turn more 6. Replace thermocouple 7. Replace control valve
Burner does not light after pilot is lit (GA9050A-1 Only)	<ol style="list-style-type: none"> 1. Burner orifice clogged 2. Inlet gas pressure is too low 3. Thermocouple leads disconnected or improperly connected 	<ol style="list-style-type: none"> 1. Clean burner orifice 2. Contact local natural or propane/LP gas company 3. Reconnect leads
Delayed ignition burner (GA9050A-1 Only)	<ol style="list-style-type: none"> 1. Pilot flame needs adjusting 2. Wrong pilot orifice 	<ol style="list-style-type: none"> 1. Adjust pilot flame for approximately 2" blue flame 2. Replace pilot orifice set

TROUBLESHOOTING

Continued



WARNING: If you smell gas

- Shut off gas supply.
- Do not try to light any appliance.
- Do not touch any electrical switch; do not use any phone in your building.
- Immediately call your gas supplier from a neighbor's phone. Follow the gas supplier's instructions.
- If you cannot reach your gas supplier, call the fire department.

IMPORTANT: Operating log set where impurities in air exist may create odors. Cleaning supplies, paint, paint remover, cigarette smoke, cements and glues, new carpet or textiles, etc., create fumes. These fumes may mix with combustion air and create odors. These odors will disappear over time.

OBSERVED PROBLEM	POSSIBLE CAUSE	REMEDY
Log Set produces a clicking/ticking noise just after burner is lit or shut off	1. Metal expanding while heating or contracting while cooling	1. This is normal with most log sets. If noise is excessive, contact qualified service person
Log Set produces unwanted odors	1. Log Set burning vapors from paint, hair spray, glues, cleaners, chemicals, new carpet, etc. (See <i>IMPORTANT</i> statement above) 2. Gas leak. See Warning statement at top of page	1. Open flue to maximum. Stop using odor causing products while log set is running 2. Locate and correct all leaks (see <i>Checking Gas Connections</i> , page 8)
Gas odor even when control knob is in OFF position	1. Gas leak. See Warning statement at top of page 2. Control valve defective	1. Locate and correct all leaks (see <i>Checking Gas Connections</i> , page 8) 2. Replace control valve
Gas odor during combustion	1. Gas leak. See Warning statement at top of page	1. Locate and correct all leaks (see <i>Checking Gas Connections</i> , page 8)

SERVICE HINTS

When Gas Pressure is Too Low

- pilot will not stay lit
- burners will have delayed ignition
- heater will not produce specified heat
- propane/LP gas supply may be low

You may feel your gas pressure is too low. If so, contact your local propane/LP or natural gas supplier.

REPLACEMENT PARTS

Note: Use only original replacement parts. This will protect your warranty coverage for parts replaced under warranty.

PARTS UNDER WARRANTY

Contact authorized dealers of this product. If they can't supply original replacement part(s), call DESA Heating, LLC at 1-866-672-6040.

When calling DESA Heating, LLC, have ready:

- your name
- your address
- model and serial numbers of your heater
- how heater was malfunctioning
- purchase date

TECHNICAL SERVICE

You may have further questions about installation, operation, or troubleshooting. If so, contact DESA Heating, LLC at 1-866-672-6040. When calling please have your model and serial numbers of your heater ready.

You can also visit DESA Heating, LLC's web site at www.desatech.com.

Usually, we will ask you to return the part to the factory.

PARTS NOT UNDER WARRANTY

Contact authorized dealers of this product. If they can't supply original replacement part(s), call DESA Heating, LLC at 1-866-672-6040 for referral information. A list of authorized dealers can be found by visiting www.desatech.com.

When calling DESA Heating, LLC, have ready:

- model and serial numbers of your heater
- the replacement part number

PARTS

MODELS CVSR18, CVSR24, CPVSR18 AND CPVSR24

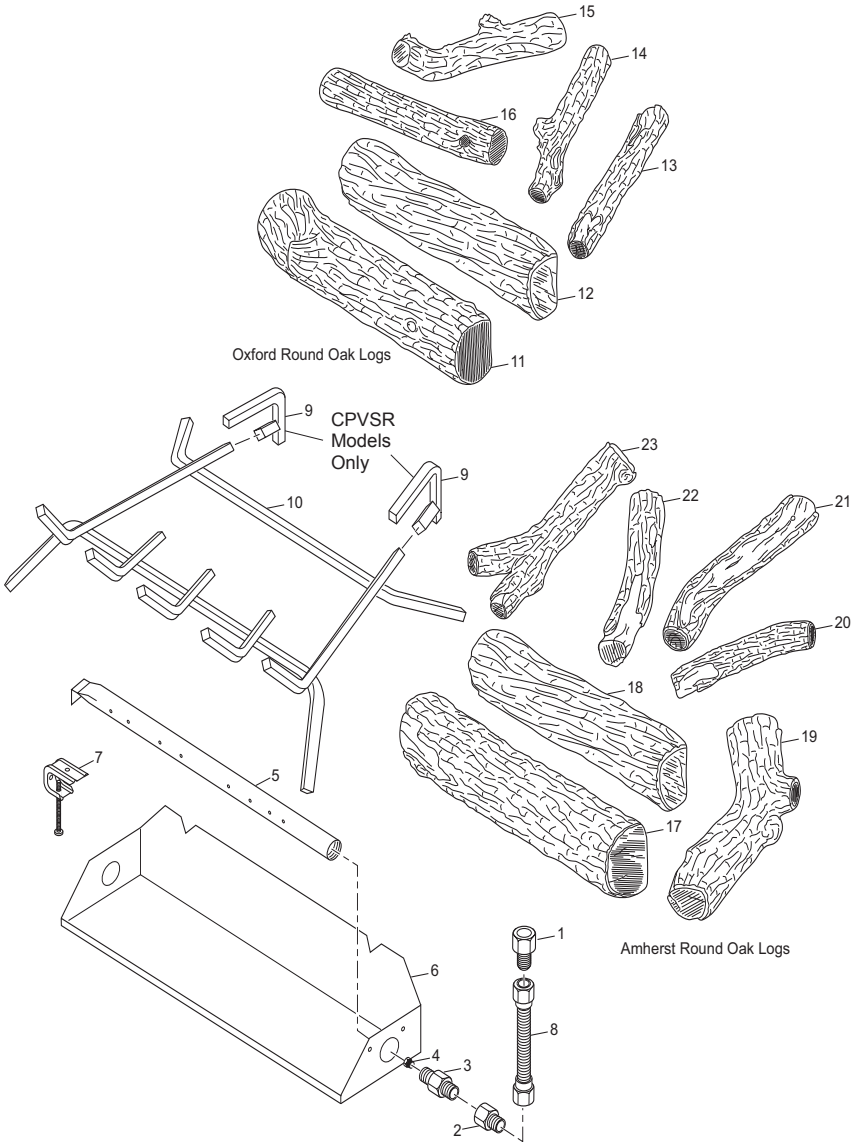

PARTS

This list contains replaceable parts used in your log set. When ordering parts, follow the instructions listed under Replacement Parts on page 19 of this manual.

KEY			CVSR18	CVSR24	CPVSR18	CPVSR24	QTY.
NO.	PART NO.	DESCRIPTION					
1	901056-01	Brass 3/8 FLR x 1/2 FPT Adapter	•	•	•	•	1
2	901059-01	Brass 3/8 FLR x 3/8 FPT Adapter	•	•	•	•	1
3	901066-01	Brass Air Mixer - Natural Gas	•	•	•	•	1
4	901064-02	Natural Gas Injector	•		•		1
	901064-03	Natural Gas Injector		•		•	1
5	901208-01	Burner Manifold	•		•		1
	901208-02	Burner Manifold		•		•	1
6	**	Burner Pan	•	•	•	•	1
7	901242-01	Damper Clamp - Std. Assembly	•	•	•	•	1
8	101628-01	Gas Line - 10" Flex	•	•	•	•	1
9	901431-01	Grate Steps			•	•	2
10	901243-01	Log Grate, 1/2"	•				1
	901243-02	Log Grate, 1/2"		•			1
	901246-01	Log Grate, 5/8"			•		1
	901246-02	Log Grate, 5/8"				•	1
11	901459-01	Bottom Front Log (CPR-18)	•				1
	901459-01	Bottom Front Log (CPR-24)		•			1
12	901458-01	Bottom Rear Log (CR-16)	•				1
	901458-01	Bottom Rear Log (CR-20)		•			1
13	901095-01	CPR12 Top Log	•	•			1
14	901096-01	CPR13Y Top Log		•			1
15	901094-01	CPR13 Top Log	•	•			1
16	901097-01	CPR14 Top Log	•	•			1
17	901640-01	Bottom Front Log (CHR-18)			•		1
	901640-02	Bottom Front Log (CHR-24)				•	1
18	901458-01	Bottom Rear Log (CR-16)			•		1
	901458-02	Bottom Rear Log (CR-20)				•	1
19	901104-01	Top Log (CHR-15)				•	1
20	901102-01	Top Log (CHR-10)			•	•	1
21	901100-01	Top Log (CHR-11)			•	•	1
22	901101-01	Top Log (CHR-13Y)			•	•	1
23	901103-01	Top Log (CHR-13Y)			•	•	1
PARTS AVAILABLE — NOT SHOWN							
	901156-01	0.4# Bag Embers	•	•	•	•	1
	901155-01	1.0# Bag Ash Bed Material (Vermiculite)	•	•	•	•	1

**Not a field replaceable part.

PARTS

MODELS CVDR18, CVDR24 AND CVDR30

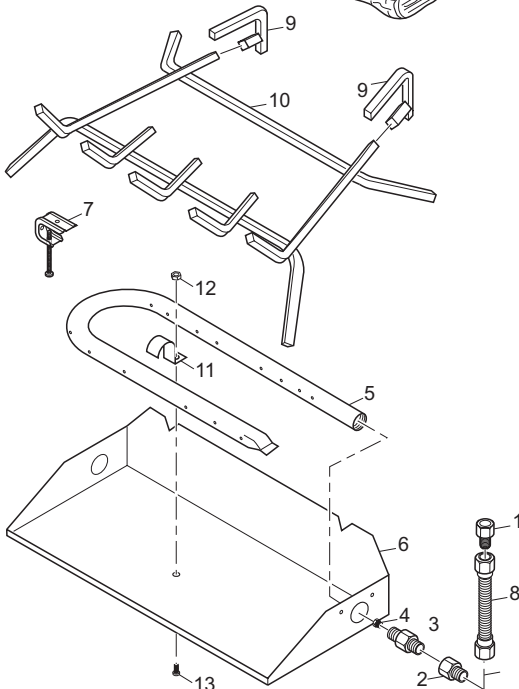
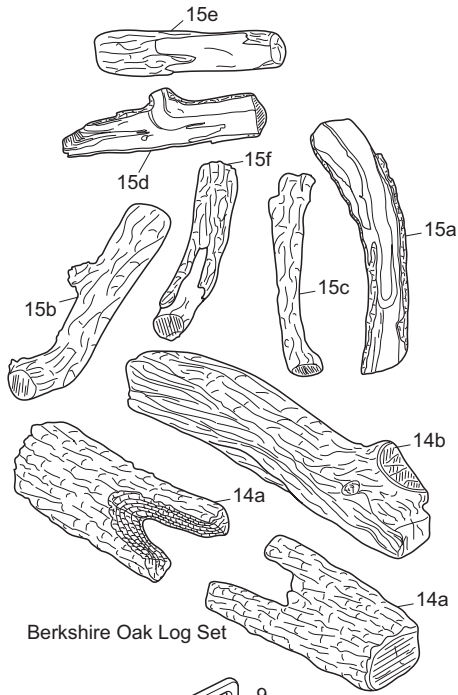

PARTS

This list contains replaceable parts used in your log set. When ordering parts, follow the instructions listed under Replacement Parts on page 19 of this manual.

KEY						
NO.	PART NO.	DESCRIPTION	CVDR18	CVDR24	CVDR30	QTY
1	901056-01	Brass 3/8 FLR x 1/2 FPT Adapter	•	•	•	1
2	901059-01	Brass 3/8 FLR x 3/8 FPT Adapter	•	•	•	1
3	901066-01	Brass Air Mixer - Natural Gas	•	•	•	1
4	901064-02	Natural Gas Injector	•			1
	901064-03	Natural Gas Injector		•		1
	901064-04	Natural Gas Injector			•	1
5	901207-01	Burner Manifold	•			1
	901207-02	Burner Manifold		•		1
	901207-03	Burner Manifold			•	1
6	**	Burner Pan	•	•	•	1
7	901242-01	Damper Clamp - Std. Assembly	•	•	•	1
8	101628-01	Gas Line - 10" Flex	•	•	•	1
9	901431-01	Grate Steps	•	•	•	2
10	901246-01	Log Grate	•			1
	901246-02	Log Grate		•		1
	901246-03	Log Grate			•	1
11	901681-01	Burner Strap	•	•	•	1
12	901078-01	Nut #8/32	•	•	•	1
13	901076-01	Screw #8/32 x 3/8	•	•	•	1
14a	901461-01	Bottom Front (CC-8)	•			2
	901461-02	Bottom Front (CS-12)		•		2
	901461-03	Bottom Front (CC-14)			•	2
14b	901111-01	Bottom Rear Log (CS-15)	•			1
	901111-02	Bottom Rear Log (CS-20)		•		1
	901111-03	Bottom Rear Log (CS-27)			•	1
15a	901090-01	Top Log (CS-16)			•	1
15b	901094-01	Top Log (CPR-13)	•	•	•	1
15c	901101-01	Top Log (CHR-13)		•	•	1
15d	901089-01	Top Log (CS-12)			•	1
15e	901118-01	Top Log (VCR-9)	•	•	•	1
	901107-01	Top Log (CCR-15)			•	1
15f	901120-01	Top Log (VCR-11)	•	•	•	1
PARTS AVAILABLE — NOT SHOWN						
	901156-01	0.4# Bag Embers	•	•	•	1
	901155-01	1.0# Bag Ash Bed Material (Vermiculite)	•	•	•	1

**Not a field replaceable part.

PARTS

MODELS BFLT18 AND BFLT24

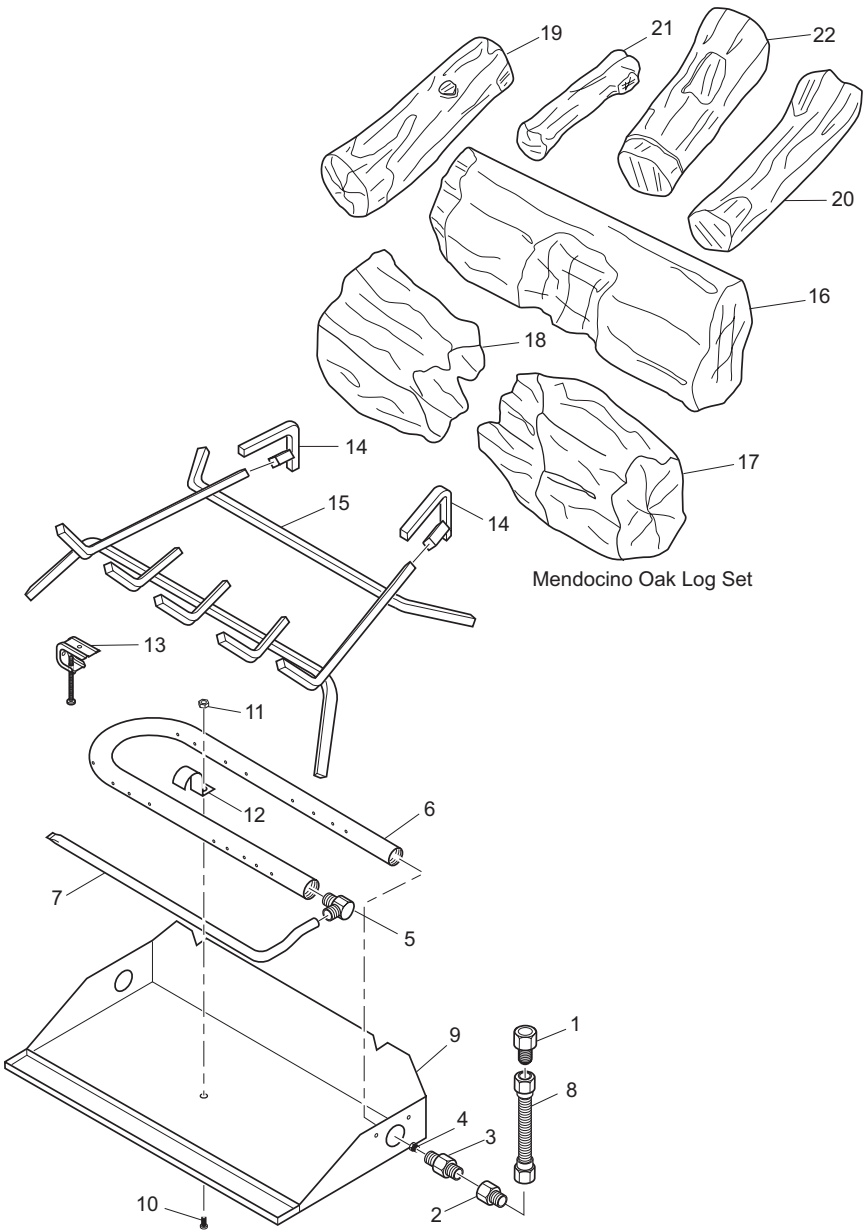

PARTS

This list contains replaceable parts used in your log set. When ordering parts, follow the instructions listed under Replacement Parts on page 19 of this manual.

KEY NO.	PART NO.	DESCRIPTION	BFLT18		BFLT24		QTY.
1	901056-01	3/8 FLR x 1/2 FPT Adapter	•	•	•	•	1
2	901059-01	3/8 FLR x 3/8 FPT Adapter	•	•	•	•	1
3	901066-01	Brass Air Mixer - Natural Gas	•	•	•	•	1
4	901064-03	Natural Gas Injector	•	•	•	•	1
	901064-04	Natural Gas Injector	•	•	•	•	1
5	110331-01	1/2 MPT x 3/8 Compression Fitting	•	•	•	•	1
6	110332-01	Burner Manifold	•	•	•	•	1
	110332-02	Burner Manifold	•	•	•	•	1
7	110325-01	Front Burner	•	•	•	•	1
	110325-02	Front Burner	•	•	•	•	1
8	101628-01	Gas Line - 12" Flex	•	•	•	•	1
9	**	Burner Pan	•	•	•	•	1
10	901076-01	Screw #8/32 x 3/8"	•	•	•	•	1
11	901078-01	Nut #8/32	•	•	•	•	1
12	901681-01	Burner Strap	•	•	•	•	1
13	901242-01	Damper Clamp - Std. Assembly	•	•	•	•	1
14	901431-01	Grate Steps	•	•	•	•	2
15	901246-01	Log Grate	•	•	•	•	1
	901246-02	Log Grate	•	•	•	•	1
16	110300-01	Rear Log - Mendocino Oak	•	•	•	•	1
	110303-01	Rear Log - Mendocino Oak	•	•	•	•	1
17	110299-01	Front Right Split Log - Mendocino Oak	•	•	•	•	1
	110302-01	Front Right Split Log - Mendocino Oak	•	•	•	•	1
18	110298-01	Front Left Split Log - Mendocino Oak	•	•	•	•	1
	110301-01	Front Left Split Log - Mendocino Oak	•	•	•	•	1
19	110292-01	Left Top Log - Mendocino Oak	•	•	•	•	1
20	110293-01	Right Top Log - Mendocino Oak	•	•	•	•	1
21	110295-01	Left Center Top Log - Mendocino Oak	•	•	•	•	1
22	110294-01	Right Center Top Log - Mendocino Oak	•	•	•	•	1
PARTS AVAILABLE — NOT SHOWN							
	901156-01	0.4# Bag Embers	•	•	•	•	1
	901155-01	1.0# Bag Ash Bed Material (Vermiculite)	•	•	•	•	1

**Not a field replaceable part.

ACCESSORIES

Purchase these accessories from your local dealer. If they can not supply these accessories call DESA Heating, LLC at 1-866-672-6040 for information. You can also write to the address listed on the back page of this manual.

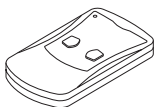

RECEIVER AND HAND-HELD ON/OFF REMOTE CONTROL KIT HRC100 SERIES

For all models. Allows the gas log set to be turned on and off by using the hand-held remote control. Valve/Pilot Kit GA9150A must be purchased to use this remote.

WALL-MOUNT ON/OFF SWITCH GWMS2

For all models. Allows the gas log set to be turned on and off with a wall switch. Valve/Pilot Kit GA9150A must be purchased to use this remote.

MANUAL CONTROL ON/OFF SAFETY VALVE/PILOT KIT - GA9050A-1

For all models. Contains components for propane/LP conversion.

REMOTE CONTROL READY ON/OFF SAFETY VALVE/PILOT KIT - GA9150A

For all models. Required for remote control operation. Contains components for propane/LP conversion.

INDIVIDUAL ROUND LOG - GA9450A

For decorative purposes only. Not to be used as additional logs on unit.

INDIVIDUAL SPLIT LOG - GA9550A

For decorative purposes only. Not to be used as additional logs on unit.

ASH BED MATERIAL (Vermiculite) GA9750A

For all models. Use for firebox decoration only.

GLOWING EMBERS - GA9950A

For all models. Use for firebox decoration only.

SILICA SAND - GA9850A

For all models. Use for firebox decoration only.

LAVA ROCK - GA6067A

For all models. Use for firebox decoration only.

DECORATIVE ASH BED CONTROL COVER - CDABKA

An attractive way to cover control knob and piezo ignitor.

WARRANTY

KEEP THIS WARRANTY

Model (located on product or identification tag) _____

Serial No. (located on product or identification tag) _____

Date Purchased _____

Keep receipt for warranty verification.

DESA HEATING, LLC LIMITED WARRANTIES

New Products

Standard Warranty: DESA Heating, LLC warrants this new product and any parts thereof to be free from defects in material and workmanship for a period of one (1) year from the date of first purchase from an authorized dealer provided the product has been installed, maintained and operated in accordance with DESA Heating, LLC's warnings and instructions.

For products purchased for commercial, industrial or rental usage, this warranty is limited to 90 days from the date of first purchase.

Factory Reconditioned Products

Limited Warranty: DESA Heating, LLC warrants factory reconditioned products and any parts thereof to be free from defects in material and workmanship for 30 days from the date of first purchase from an authorized dealer provided the product has been installed, maintained and operated in accordance with DESA Heating, LLC's warnings and instructions.

Terms Common to All Warranties

The following terms apply to all of the above warranties:

Always specify model number and serial number when contacting the manufacturer. To make a claim under this warranty the bill of sale or other proof of purchase must be presented.

This warranty is extended only to the original retail purchaser when purchased from an authorized dealer, and only when installed by a qualified installer in accordance with all local codes and instructions furnished with this product.

This warranty covers the cost of part(s) required to restore this product to proper operating condition and an allowance for labor when provided by a DESA Heating, LLC Authorized Service Center or a provider approved by DESA Heating, LLC. Warranty parts must be obtained through authorized dealers of this product and/or DESA Heating, LLC who will provide original factory replacement parts. Failure to use original factory replacement parts voids this warranty.

Travel, handling, transportation, diagnostic, material, labor and incidental costs associated with warranty repairs, unless expressly covered by this warranty, are not reimbursable under this warranty and are the responsibility of the owner.

Excluded from this warranty are products or parts that fail or become damaged due to misuse, accidents, improper installation, lack of proper maintenance, tampering, or alteration(s).

This is DESA Heating, LLC's exclusive warranty, and to the full extent allowed by law; this express warranty excludes any and all other warranties, express or implied, written or verbal and limits the duration of any and all implied warranties, including warranties of merchantability and fitness for a particular purpose to one (1) year on new products and 30 days on factory reconditioned products from the date of first purchase. DESA Heating, LLC makes no other warranties regarding this product.

DESA Heating, LLC's liability is limited to the purchase price of the product, and DESA Heating, LLC shall not be liable for any other damages whatsoever under any circumstances including indirect, incidental, or consequential damages.

Some states do not allow limitations on how long an implied warranty lasts or the exclusion or limitation of incidental or consequential damages, so the above limitation or exclusion may not apply to you.

This warranty gives you specific legal rights, and you may also have other rights which vary from state to state.

For information about this warranty contact:



DESA Heating, LLC
2701 Industrial Drive
Bowling Green, KY 42101
www.desatech.com
1-866-672-6040

901265-01
Rev. S
12/08



901265 01
NOT A UPC