

Instruction
booklet

Electric
hob

ZBE 603

Thank you for selecting our appliance

We wish you lots of enjoyment with your new appliance and we hope that you will consider our brand again when purchasing household appliances. Please read this user manual carefully and keep it throughout the product life cycle as a reference document. The user manual should be passed on to any future owner of the appliance.

Contents

For the User

Description of the Hob	3
Important Safety Information	4
Before the First Use of the Appliance	6
Operation	6
Maintenance and Cleaning	10
Something Not Working?	11
Service and original Spare Parts	20
Guarantee/Customer Service	21
European Guarantee	22

For the Installer

Electrical Connections	14
Wiring Diagram	17
Installation	18
Building In	19

Description of the Hob

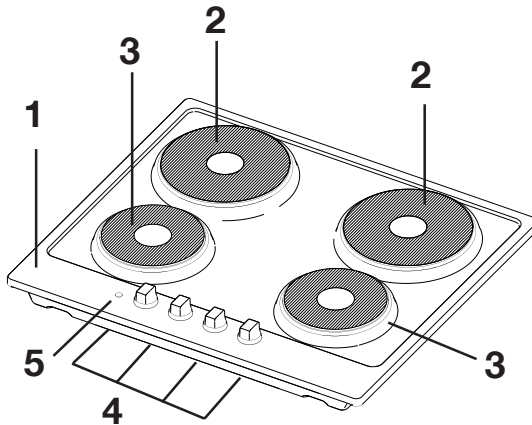

1. Hob top
2. Rapid hotplate - 2000 W - 180 mm dia.
3. Rapid hotplate - 1500 W - 145 mm dia.
4. Control knobs
5. Mains On indicator light



Important Safety Information

You MUST read these warnings carefully before installing or using the hob. If you need assistance, contact our Customer Care Department on 08705 727 727.

Installation

- This hob must be installed by qualified personnel, according to the manufacturer's instructions and to the relevant British Standards.
- Before carrying out any operation, make sure the appliance is DISCONNECTED from the power supply.
- Remove all packaging before using the hob.
- After unpacking the appliance, make sure it is not damaged and that the power cable is in perfect condition. Otherwise, contact the dealer before using the appliance.
- The Manufacturer declines any liability if the accident-prevention regulations are not respected.

People safety

- This appliance must only be used by adults. Make sure children do not play with the appliance or touch the controls.
- This appliance is not intended for use by children or other persons whose physical, sensory or mental capabilities or lack of experience and knowledge prevents them from using the appliance safely without supervision or instruction by a responsible person to ensure that they can use the appliance safely.

- The exposed parts of this appliance become hot during cooking and remain so for some time even after the appliance is turned off. Keep children away until the appliance has cooled.

During use

- This product is designed for non-professional home use, for cooking food. Do not use it for any other purpose.
- Modifying or attempting to change the characteristics of this product is hazardous.
- Keep the appliance clean. Food residuals can create the risk of fire.
- In case of faults, never try to repair the appliance on your own. Repairs carried out by unqualified persons can cause damage and accidents. Firstly, consult this handbook. If you do not find the necessary information, contact the nearest Service Centre. Assistance for this appliance must be carried out by an authorised Technical Service Centre. Always demand the use of original spare parts.
- After using the appliance, make sure all the controls are in the "CLOSED" or "OFF" position.
- Do not use steam or steam appliances to clean the equipment.
- When using a power outlet near this appliance, make sure the cords of any electrical appliances being used do not touch it and are far enough away from its hot parts.



Environmental information

- All the materials used are environmentally friendly and recyclable. Please make your contribution to safeguarding the environment by using the special differentiated waste collection channels.
- Appliances that are no longer used or unusable are not worthless waste. Through ecological disposal, various materials used in manufacturing your appliance can be recovered.
- Find out about the possibilities of disposal from your specialised dealer or local Council.
- When disposing of an old appliance, make it unusable, by cutting off the cable.



- The symbol  on the product or on its packaging indicates that this product may not be treated as household waste. Instead it shall be handed over to the applicable collection point for the recycling of electrical and electronic equipment. By ensuring this product is disposed of correctly, you will help prevent potential negative consequences for the environment and human health, which could otherwise be caused by inappropriate waste handling of this product. For more detailed information about recycling of this product, please contact your local city office, your household waste disposal service or the shop where you purchased the product.

Guide to Use the instructions

The following symbols will be found in the text to guide you throughout the Instructions:



Safety Instructions



Step by step instructions for an operation



Hints and Tips



Environmental information

These instructions are only valid for countries whose identification symbols appear on the handbook cover and on the appliance.

Keep this instruction book for future reference and ensure it is passed on to any new owner.



This appliance is manufactured according to the following EEC directives:

2006/95 EEC - 93/68 EEC - 89/336 EEC, current edition.

Before the First Use of the Appliance

⚠ Before using the appliance remove all packaging, including the advertising labels and any protective film.

☞ When using the hob for the first time:

- 1) place on all the plates a pan filled with some water;
- 2) switch the plates on for about 10 minutes at "maximum" position until water inside the pans boils;
- 3) then, turn the control knob to "minimum" and allow the plates to run for approximately 20 minutes;
- 4) open a window for ventilation.

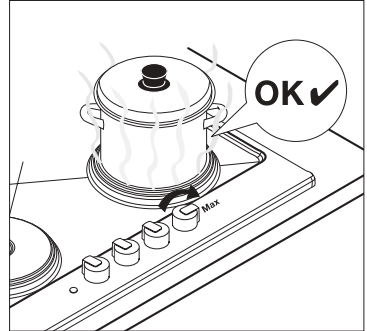

Fig. 1

i During this time, the plates may smoke a little and an unpleasant odour may be emitted. This is absolutely **normal** and it is caused by residues of manufacturing.

Once this operation is carried out, let the plates to cool down, then clean them with a soft cloth soaked in warm water.

Operation

Electric Hotplates

To switch on a hotplate, turn the relevant control knob anticlockwise to the required heat setting.

The control knob is numbered 1 - 6

- 0** - OFF
- 1** - Minimum
- 6** - Maximum

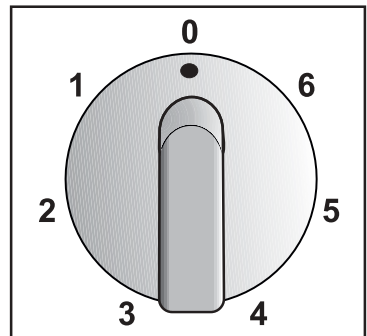

Fig. 2

Rapid Hotplates

The rapid hotplates are indicated by a red dot, and will heat up more quickly than a normal plate. As the red dots are painted on the plate, they may deteriorate during use and even disappear completely after a period of time. **This will not affect the performance of the hob.**



It is important to note that the plate may smoke and produce a slightly unpleasant odour when used for the first time. This is quite normal and will disappear after a short while.

Electric Hotplates Control Light

The Hotplates Control Light will come on each time a cooking zone is switched on.

Suggestions for the correct setting of the plates are given in the following table.

OFF	0	
Very Gentle	1	To keep food warm To melt butter and chocolate.
Gentle	2	To prepare cream-sauces, stews and milk puddings or to fry eggs.
Slow	3	Dried vegetables, frozen food, fruit, boiling water or milk.
Medium	4	Boiled potatoes, fresh vegetables, pâtés, soups, broths, pancakes or fish.
High	5	Larger stews, meat roll, fish, omelettes, steaks.
Fast	6	Steaks, escalopes and frying.

For the correct use of the hot-plates

For better efficiency of the electric hotplates and lower electricity consumption:

- switch on the hotplates only after placing the pots on them.
- For cooking on the electric hotplates it is advisable to use triple-bottom pots of the same width as the cooking zone, or slightly larger (Fig. 3).
- Do not use wet pots on the electric hot-plates, and do not place wet lids on the switched off hot-plates, because the moisture and condensate could damage them.
- If possible, place lids on the pots. Copper or aluminium pots and pans are not very suitable for cooking on the electric hotplates, because they can leave residues, stains and marks. Likewise, meat grills in cast iron or other alloys are not suitable for cooking on the electric hotplates, because they cause dangerous accumulation of heat.

Also, the rough bottom can scratch the cooktop and the material can stain it. Possibly choose a meat grill in stainless steel with triple bottom.

The use of glass containers is also inadvisable, because they usually have very uneven bottoms. Never use plastic containers.

- Do not place unstable or deformed pots on the hotplates because they could tip over or spill their contents and thus cause accidents.
- Pots must not enter the control zone.
- Make sure boiling liquids do not spill onto the hotplates.

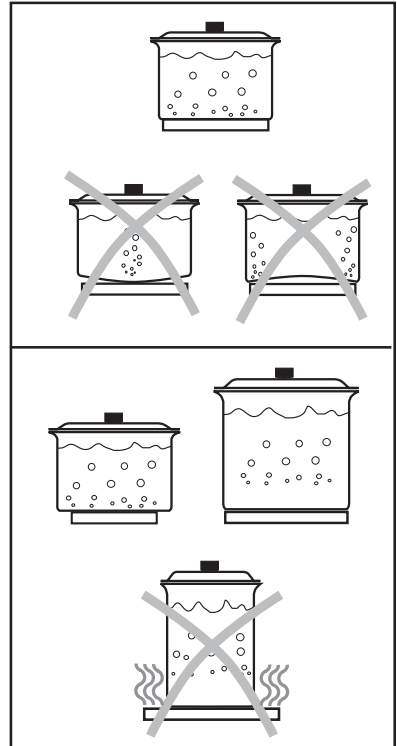

Fig. 3

- Do not leave a hotplate switched on without a pot or with an empty pot.
- Do not place a pot on a cold hotplate or leave it to cool on a switched-off hotplate. This could cause damaging condensation to form.
- For faster cooking and to avoid heat dispersion, it is advisable to use flat-bottomed pots, to ensure maximum contact of the bottoms with the cooking zone.
- Take care never to lean or reach over a hot electric plate. Always point pan handles inward or over the work surface next to the hob to avoid accidentally knocking over a pan as you pass by.
- Do not use the hotplate to warm the room.



Take care when frying food in hot oil or fat, as the overheated splashes could easily ignite.



The stainless steel can become tarnished if excessively heated. Therefore prolonged cooking with potstones, earthenware pans or cast-iron plates is inadvisable. Also, do not use aluminium foil to protect the top during use.

Maintenance and Cleaning

 **Before any maintenance or cleaning can be carried out, you must DISCONNECT the hob from the electricity supply.**

 **This appliance cannot be cleaned with steam or with a steam cleaning machine.**

The hob is best cleaned whilst it is still warm, as spillage can be removed more easily than if it is left to cool.

The Hob Top

Regularly wipe over the hob top using a soft cloth well wrung out in warm water to which a little washing up liquid has been added. Avoid the use of the following:

- household detergent and bleaches;
- impregnated pads unsuitable for non-stick saucepans;
- steel wool pads;
- bath/sink stain removers.

Should the hob top become heavily soiled, the following products are recommended:

- For stainless steel hobs use a proprietary stainless steel cleaner.
- For other hobs use Hob Brite or Bar Keepers Friend.

The control knobs may be removed by carefully pulling them upward for easier cleaning.

 **Do not leave acid or alkaline substances (e.g. vinegar, salt, lemon juice, etc.) on the cooktop.**

The Hotplates

Spills onto the actual plate should be removed using warm water and a soft brush, nylon or plastic scourer. To keep the plates looking as new, hotplate conditioner can be purchased from most hardware stores, e.g. "4 Hob" by HomeCare Products (follow the manufacturer's instruction for use).

Alternatively, wipe the plates with a drop of olive oil on a kitchen towel to avoid rust. It is important to note that the plate will smoke a little and produce a slightly unpleasant odour when next used.

Stainless steel parts: the stainless steel spill rings may become straw coloured with use. Use a proprietary stainless steel cleaner to remove this straw discolouration. This also applies to the area around the hotplates on stainless steel hobs.

 Failure to clean and condition hotplates may lead to rust and corrosion forming on the surface.

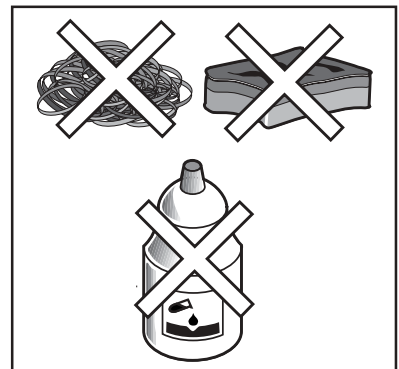

Fig. 4

Something Not Working?

If the hob is not working correctly, please carry out the following checks before contacting your local Service Force Centre.

IMPORTANT: If you call out an engineer to a fault listed below, or to repair a fault caused by incorrect use or installation, a charge will be made even if the appliance is under guarantee.

SYMPTOM	SOLUTION
<ul style="list-style-type: none"> ■ The plate does not heat up. 	<ul style="list-style-type: none"> ◆ Check that the unit is plugged in and the electrical supply is switched on. ◆ Check the mains fuse has not blown. ◆ Check the correct control knob has been turned.
<ul style="list-style-type: none"> ■ The plate is not giving satisfactory results. 	<ul style="list-style-type: none"> ◆ Check the plate is clean and dry ◆ Check the cooking pan is the correct size for the plate. ◆ Check the cooking pan has a flat bottom. ◆ Check the setting is correct for the type of cooking.

If after all these checks, your hob still does not operate correctly, contact your local Service Force Centre.

Please note that it will be necessary to provide proof of purchase for any in-guarantee service calls.

In-guarantee customers should ensure that the above checks have been made as the engineer will make a charge if the fault is not a mechanical or electrical breakdown.

Instructions for the Installer

Engineers technical data

Heating elements ratings

Rapid front left hotplate		
	Ø 145 mm	1500 W
Rapid back left hotplate		
	Ø 180 mm	2000 W
Rapid front right hotplate		
	Ø 145 mm	1500 W
Rapid back right hotplate		
	Ø 180 mm	2000 W
Total rating		7000 W
Voltage tension		230 V~ 50 Hz

Cut out dimensions

Width:	560 mm
Depth:	480 mm

Overall dimensions

Width:	594 mm
Depth:	510 mm

Important safety requirements

This hob must be installed in accordance with the IEE Wiring Regulations (Current Edition).

Detailed recommendations are contained in the following British Standards Codes Of Practice: B.S. 6172/ B.S. 5440, Par. 2 and B.S. 6891 Current Editions.

Location

This hob has been registered as a "Class X" appliance according to Fire Risk Regulations. Minimum distances detailed below must be observed. The hob may be located in a kitchen, a kitchen/diner or bed sitting room, but not in a bathroom or shower room.

Ensure that there is a minimum distance of 55 mm between the rear cut out edge and the wall.

A minimum distance of 100 mm must be left between the side edges of the cut out and any adjacent cabinets or walls.

The minimum distance combustible material can be fitted above the hob in line with the edges of the hob is 400 mm. If it is fitted below 400 mm a space of 50 mm must be allowed from the edges of the hob.

The minimum distance combustible material or a cooker hood can be fitted above the hob is 650 mm.

Dimensions are given in mm.

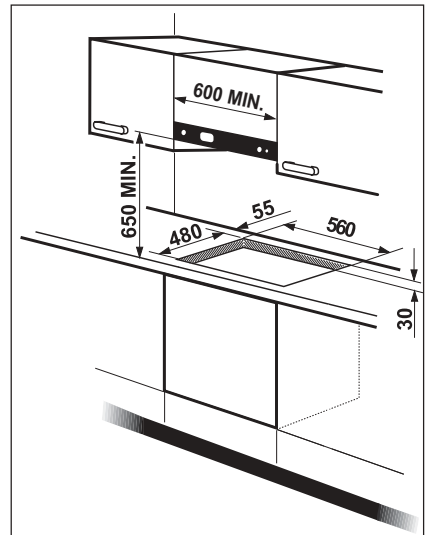

Fig. 5

Electrical Connections

⚠ Any electrical work required to install this hob should be carried out by a qualified electrician or competent person, in accordance with the current regulations.

⚠ THIS HOB MUST BE EARTHED.

The manufacturer declines any liability should these safety measures not be observed.

This hob is designed to be connected to a 230 V~ 50 Hz electrical supply.

Before switching on, make sure the electricity supply voltage is the same as that indicated on the hob rating plate. The rating plate is located on the bottom of the hob. A copy is attached on the back cover of this book.

Before carrying out the connection, make sure:

1) the limiter valve and the electrical system can take the appliance load (see the rating plate);

2) the supply system is equipped with an efficient earth connection in compliance with the current standards and regulations;

3) the outlet or omnipolar switch used for connection are easily accessible with the appliance installed.

The appliance is not equipped with a power cable.

A cable of section adequate for the load must be installed on the equipment. The type of cable must have at least T90 temperature characteristics. It is advisable to use the following types of cables or others with similar characteristics: H05 V2V2-F. The

cable has three wires. The earth wire is yellow/green and must be approx. 2 cm longer than the phase and neutral wires (Fig. 6). Fit the cable with a plug suitable for the load and connect it to a suitable safety socket.

To connect directly to the mains, a suitable omnipolar switch complying with current standards and with a contact gap of at least 3 mm must be installed between the appliance and the electrical system.

The yellow/green earth wire must not be interrupted by the switch. The brown phase wire (coming from terminal "L" on the terminal block) must always be connected to the power supply phase.

In any case the power cable must be positioned in such a way that no part of it reaches a temperature of 50°C higher than the ambient temperature.

The cable is guided by means of clamps fixed to the side of the cabinet, in order to avoid any contact with the equipment beneath the cooktop.

The Manufacturer declines any liability if the accident-prevention regulations are not respected.

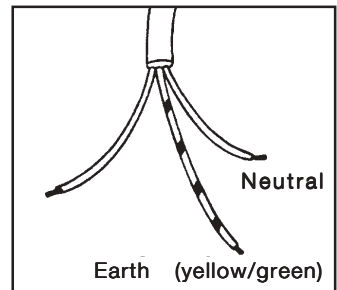

Fig. 6

Earth (yellow/green)



Ensure that the hob supply cord does not come into contact with surfaces with temperatures higher than 50 deg. C.



The replacement of electric cable must be carried out exclusively by the service force centre or by personnel with similar competencies, in accordance with the current regulations.

Supply Cable Specifications

For Uk use only

Connection via	Min. size Cable / flex	Cable / flex type	Fuse
• Appliance Control Circuit	6 mm ²	PVC/PVC twin and earth	30 A

For Europe use only

Min. size Cable / flex	Cable / flex type	Fuse
2.5 mm ²	H05 V2V2-F (T90)	20 A

Electrical connection to the terminal box

The appliance is fitted with a five pole terminal box whose cables are predisposed for a 230 V monophase function (Fig. 7).

In case of a different voltage, carry out the connection as shown in the table "CHOICE OF CONNECTION CABLE AND FUSE GUAGE" below.

The earth wire should be connected to the terminal marked by the sign .

After having connected the wire to the terminal secure it with a cable clip.

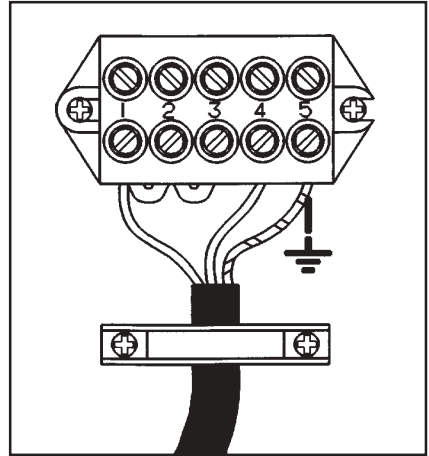
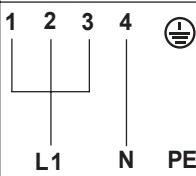
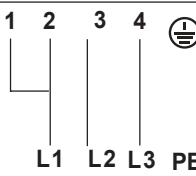
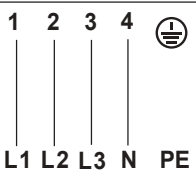
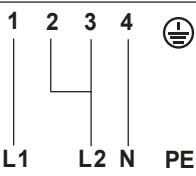
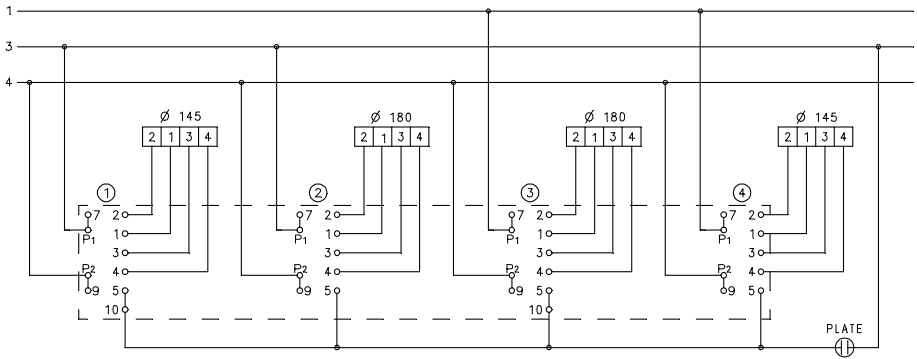

Fig. 7

CHOICE OF CONNECTION CABLE AND FUSE GUAGE (in Amps)

Type of connection	Monophase	Triphase	Triphase Y 3f. + neutre	Biphase Y 2f. + neutre
Connection cable with terminal box	 <p>L1 N PE</p>	 <p>L1 L2 L3 PE</p>	 <p>L1 L2 L3 N PE</p>	 <p>L1 L2 N PE</p>
Network tension	230 V ~	230 V 3 ~	400 V 3N ~	400 V 2N ~
Heating element tension	230 V	230 V	230 V	230 V
All-electric appliance	3 X 2,5 mm ²	4 X 1,5 mm ²	5 X 1,5 mm ²	4 X 1,5 mm ²
	24 A	13 A	13 A	13 A

Wiring Diagram



Installation

 The hob must be installed according to the instructions supplied.

The hob must be installed by **qualified personnel** to the relevant British Standards.

Please, ensure that, once the hob is installed, it is easily accessible for the engineer in the event of a breakdown.

When the hob is first installed

 Once the hob has been installed, it is important to remove any protective materials, which were put on in the factory.

The manufacturer will not accept liability, should the above instructions or any of the other safety instructions incorporated in this book be ignored.

These cooktops are designed for fitting on modular kitchen cabinets having a depth of between 550 and 600 mm and suitable characteristics.

Fitting the Hob into the worktop

Carry out the building in of the hob as follows:

- place the seals supplied with the hob on the front edge of the cut out. Then, place them at 11 mm from the side edges and at 10 mm from the rear edge, as shown in the diagram, taking care that the seals meet without overlapping.
- Place the hob in the cut out, taking care that it is centred.

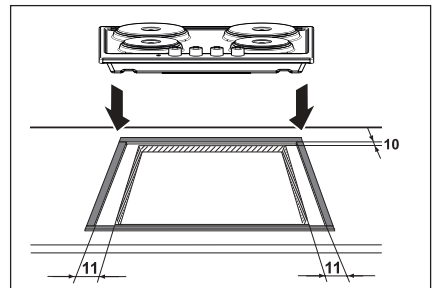

Fig. 8

- Fix the hob with the relevant fixing clamps, supplied with the kit (see diagram). When the screws have been tightened, the excess seal can be removed.

The edge of the hob forms a double seal which prevents the ingress of liquids.

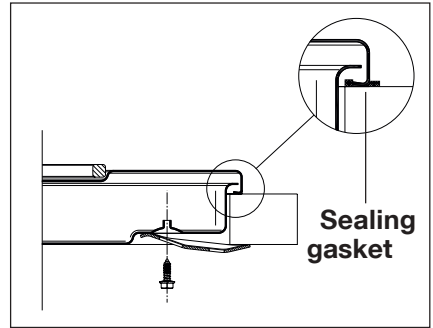

Fig. 9

Building In

On base cabinet with door

Adequate arrangements must be ensured in the construction of the cabinet, to prevent possible contact with the overheated housing of the top during operation. The recommended solution for avoiding this problem is illustrated in Fig. 10.

The panel under the top must be easily removed to allow securing and release of the top in case of technical service intervention.

On base cabinet with oven

The compartment must have the dimensions given in Fig. 5 and must be equipped with supports for allowing efficient ventilation.

Two possible solutions for preventing overheating are described in Fig. 11 and 12.

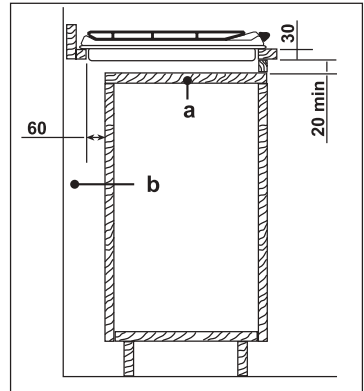

Fig. 10

- a) removable cabinet panel
- b) possible space useful for connections

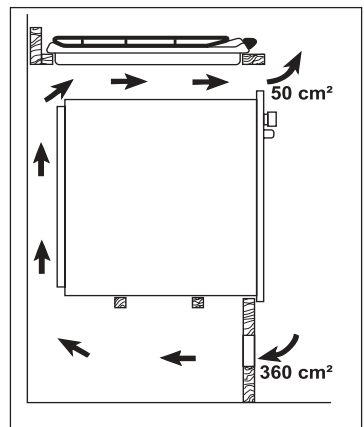

Fig. 11

The electrical connection of the top and that of the oven must be carried out separately, for electrical reasons and to facilitate frontal oven removal.

Wall units or extractor hoods must be at least 650 mm from the cooktop (Fig. 5).

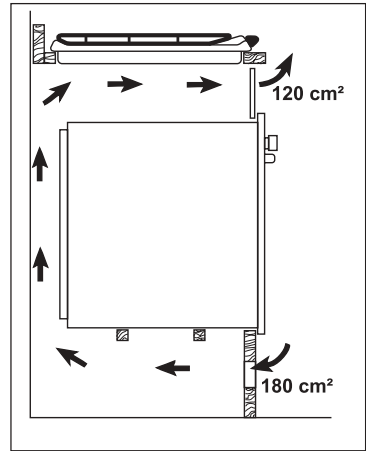

Fig. 12

Service and original spare parts

This machine, before leaving the factory, has been tested and studied by many experts and specialists, in order to give you the best results.

Any repair work which needs to be carried out should be done with the utmost care and attention.

For this reason we recommend that for any problem you contact the dealer who sold it to you, or our nearest authorized Service Centre, specifying the nature of the problem, the appliance model (Mod.), the product number (Prod. No.) and the serial number (Ser. No.) marked on the identification plate supplied in the injectors kit.

Original spareparts, certified by the product manufacturer and carrying this symbol are only available at our Service Centre and authorized spareparts shops.



Guarantee/ Customer Service

Standard guarantee conditions

We, Zanussi-Electrolux, undertake that if within 12 months of the date of the purchase this Zanussi-Electrolux appliance or any part thereof is proved to be defective by reason only of faulty workmanship or materials, we will, at our option repair or replace the same FREE OF CHARGE for labour, materials or carriage on condition that:

- The appliance has been correctly installed and used only on the electricity supply stated on the rating plate.
- The appliance has been used for normal domestic purposes only, and in accordance with the manufacturer's instructions.
- The appliance has not been serviced, maintained, repaired, taken apart or tampered with by any person not authorised by us.
- Electrolux Service Force Centre must undertake all service work under this guarantee.
- Any appliance or defective part replaced shall become the Company's property.
- This guarantee is in addition to your statutory and other legal rights.

Exclusions

- Damage or calls resulting from transportation, improper use or neglect, the replacement of any light bulbs or removable parts of glass or plastic.
- Costs incurred for calls to put right an appliance which is improperly installed or calls to appliances outside the United Kingdom.
- Appliances found to be in use within a commercial environment, plus those which are subject to rental agreements.
- Products of Electrolux manufacturer that are not marketed by Electrolux.

Service and Spare Parts

In the event of your appliance requiring service, or if you wish to purchase spare parts, please contact your local Service Force Centre by telephoning **0870 5 929 929**

Your telephone call will be automatically routed to the Service Force Centre covering your postcode area.

For the address of your local Service Force Centre and further information about Service Force, please visit the website at www.serviceforce.co.uk

Before calling out an engineer, please ensure you have read the details under the heading "Something not working?".

When you contact the Service Force Centre you will need to give the following details:

1. Your name, address and postcode.
2. Your telephone number.
3. Clear concise details of the fault.
4. The model and Serial number of the appliance (found on the rating plate).
5. The purchase date.

Please note a valid purchase receipt or guarantee documentation is required for in guarantee service calls.

Customer Care

For general enquiries concerning your Electrolux appliance, or for further information on Electrolux products please contact our Customer Care Department by letter or telephone at the address below or visit our website at www.electrolux.co.uk

Customer Care Department

Electrolux Major Appliances

Addington Way

Luton

Bedfordshire, LU4 9QQ

Tel: 08705 727 727 (*)

(*) Calls may be recorded for training purposes

European Guarantee

This appliance is guaranteed by Electrolux in each of the countries listed at the back of this user manual, for the period specified in the appliance guarantee or otherwise by law. If you move from one of these countries to another of the countries listed below the appliance guarantee will move with you subject to the following qualifications:

- The appliance guarantee starts from the date you first purchased the appliance which will be evidenced by production of a valid purchase document issued by the seller of the appliance.
- The appliance guarantee is for the same period and to the same extent for labour and parts as exists in your new country of residence for this particular model or range of appliances.
- The appliance guarantee is personal to the original purchaser of the appliance and cannot be transferred to another user.

- The appliance is installed and used in accordance with instructions issued by Electrolux and is only used within the home, i.e. is not used for commercial purposes.
- The appliance is installed in accordance with all relevant regulations in force within your new country of residence.

The provisions of this European Guarantee do not affect any of the rights granted to you by law.

www.electrolux.com

		
Albania	+35 5 4 261 450	Rr. Pjeter Bogdani Nr. 7 Tirane
Belgique/België/Belgien	+32 2 363 04 44	Bergensesteenweg 719, 1502 Lembeek
Česká republika	+420 2 61 12 61 12	Budějovická 3, Praha 4, 140 21
Danmark	+45 70 11 74 00	Sjællandsgade 2, 7000 Fredericia
Deutschland	+49 180 32 26 622	Muggenhofer Str. 135, 90429 Nürnberg
Eesti	+37 2 66 50 030	Pärnu mnt. 153, 11624 Tallinn
España	+34 902 11 63 88	Carretera M-300, Km. 29,900 Alcalá de Henares Madrid
France	www.electrolux.fr	
Great Britain	+44 8705 929 929	Addington Way, Luton, Bedfordshire LU4 9QQ
Hellas	+30 23 10 56 19 70	4, Limnou Str., 54627 Thessaloniki
Hrvatska	+385 1 63 23 338	Slavonska avenija 3, 10000 Zagreb
Ireland	+353 1 40 90 753	Long Mile Road Dublin 12
Italia	+39 (0) 434 558500	C.so Lino Zanussi, 26 - 33080 Porcia (PN)
Latvija	+37 17 84 59 34	Kr. Barona iela 130/2, LV-1012, Riga
Lietuva	+370 5 2780609	Ozo 10A, LT 08200 Vilnius
Luxembourg	+352 42 431 301	Rue de Bitbourg, 7, L-1273 Hamm
Magyarország	+36 1 252 1773	H-1142 Budapest XIV, Erzsébet királyné útja 87
Nederland	+31 17 24 68 300	Vennootsweg 1, 2404 CG - Alphen aan den Rijn
Norge	+47 81 5 30 222	Risløkkvn. 2 , 0508 Oslo
Österreich	+43 18 66 400	Herziggasse 9, 1230 Wien
Polska	+48 22 43 47 300	ul. Kolejowa 5/7, Warszawa
Portugal	+35 12 14 40 39 39	Quinta da Fonte - Edificio Gonçalves Zarco - Q 35 -2774-518 Paço de Arcos
Romania	+40 21 451 20 30	Str. Garii Progresului 2, S4, 040671 RO
Schweiz - Suisse - Svizzera	+41 62 88 99 111	Industriestrasse 10, CH-5506 Mägenwil
Slovenija	+38 61 24 25 731	Gerbičeva ulica 98, 1000 Ljubljana
Slovensko	+421 2 43 33 43 22	Electrolux Slovakia s.r.o., Electrolux Domáce spotrebiče SK, Seberínho 1, 821 03 Bratislava
Suomi	www.electrolux.fi	
Sverige	+46 (0)771 76 76 76	Electrolux Service, S:t Göransgatan 143, S-105 45 Stockholm
Türkiye	+90 21 22 93 10 25	Tarlabası caddesi no : 35 Taksim İstanbul
Россия	+7 495 937 7837	129090 Москва, Олимпийский проспект, 16, БЦ "Олимпик"

www.electrolux.com

www.zanussi-electrolux.co.uk