

OPERATING & MAINTENANCE MANUAL

EX-12 EX-22

From machine No. 91/6411- EX 12, 91/5875- EX 22

471 1562-60/01
95.38

WARNING: ALL OPERATING AND MAINTENANCE PROCEDURES SHOWN ON THE NEXT PAGE OF THIS MANUAL MUST BE FOLLOWED DAILY FOR PROPER OPERATION OF YOUR WASCOMAT MACHINE.

PLEASE ENTER THE FOLLOWING INFORMATION AS IT APPEARS ON THE MACHINE(S) DATA PLATE(S).

MACHINE TYPE OR MODEL	
MACHINE SERIAL NUMBER(S)	
ELECTRICAL CHARACTERISTICS: _____ VOLTS, _____ PHASE, _____ HZ.	

MAKE CERTAIN TO KEEP THIS MANUAL IN A SECURE PLACE FOR FUTURE REFERENCE.



NOTICE TO: OWNERS, OPERATORS AND DEALERS OF WASCOMAT MACHINES

IMPROPER INSTALLATION AND INADEQUATE MAINTENANCE, POOR HOUSEKEEPING AND WILLFUL NEGLECT OR BYPASSING OF SAFETY DEVICES MAY RESULT IN SERIOUS ACCIDENTS OR INJURY. TO ASSURE THE SAFETY OF CUSTOMERS AND/OR OPERATORS OF YOUR MACHINE, THE FOLLOWING MAINTENANCE CHECKS MUST BE PERFORMED ON A DAILY BASIS.

1. Prior to operation of the machine, check to make certain that all operating instructions and warning signs are affixed to the machine and legible. (See the following page of this manual for description and location of the signs.) Missing or illegible ones must be replaced immediately. Be sure you have spare signs and labels available at all times. These can be obtained from your dealer or Wascomat.

2. Check the door safety interlock, as follows:

- (a) OPEN THE DOOR of the machine and attempt to start in the normal manner:

For coin-operated models, insert the proper coins to start the machine.

For manually operated models, place the ON-OFF switch in the ON position and press the Start switch.

For FL and EX models, insert a program card, turn the starter knob to the Start position and place the ON-OFF switch in the ON position.

For HI-TEK microprocessor models, turn the key switch to the RUN position, choose a program and press the START button.

For SELECTA 28 models, select a wash program and press the Start button.

THE MACHINE(S) SHOULD NOT START !

- (b) CLOSE THE DOOR to start machine operation and, while it is operating, attempt to open the door without exerting extreme force on the door handle. The door should remain locked!

If the machine can start with the door open, or can continue to operate with the door unlocked, the door interlock is no longer operating properly. The machine must be placed out of order and the interlock immediately repaired or replaced. (See the door interlock section of the manual.)

3. DO NOT UNDER ANY CIRCUMSTANCES ATTEMPT TO BYPASS OR REWIRE ANY OF THE MACHINE SAFETY DEVICES AS THIS CAN RESULT IN SERIOUS ACCIDENTS.
4. **Be sure to keep the machine(s) in proper working order:** Follow **all** maintenance and safety procedures. Further information regarding machine safety, service and parts can be obtained from your dealer or from Wascomat through its Teletech Service Telephone - 516/371-0700.

All requests for assistance must include the model, serial number and electrical characteristics as they appear on the machine identification plate. Insert this information in the space provided on the previous page of this manual.

5. **WARNING:** DO NOT OPERATE MACHINE(S) WITH SAFETY DEVICES BYPASSED, REWIRED OR INOPERATIVE! DO NOT OPEN MACHINE DOOR UNTIL DRUM HAS STOPPED ROTATING!



SAFETY AND WARNINGS SIGNS

Replace If Missing Or Illegible

One or more of these signs must be affixed on each machine as indicated, when not included as part of the front instruction panel.

LOCATED ON THE OPERATING INSTRUCTION SIGN OF THE MACHINE:

CAUTION

1. Do not open washer door until cycle is completed, operating light is off, and wash cylinder has stopped rotating.
2. Do not tamper with the door safety switch or door lock.
3. Do not attempt to open door or place hands into washer to remove or add clothes during operation. This can cause serious injury.

PRECAUCION

1. No abra la puerta de la máquina lavadora sino hasta que la máquina haya terminado su ciclo, la luz operativa esté apagada y el cilindro de lavado haya completamente terminado de girar.
2. No interfiera o manipule el switch o la cerradura de la puerta.
3. No trate de abrir la puerta o meta las manos dentro de la máquina para meter o sacar ropa mientras la máquina está en operación, pues puede resultar seriamente herido.

MACHINE SHOULD NOT BE USED BY CHILDREN

LAS MÁQUINAS NO DEBEN SER USADAS POR NIÑOS

LOCATED AT THE REAR OF THE MACHINE:

INSTALLATION AND MAINTENANCE WARNINGS

1. When installed on a floor of combustible material, the floor area below this machine must be covered by a metal sheet extending to the outer edges of the machine.
2. This washing machine **MUST** be securely bolted to an uncovered concrete floor according to the installation instructions to reduce the risk of fire and to prevent serious injury, or damage to the machine.
3. This machine **MUST** be serviced and operated in compliance with manufacturer's instructions. **CHECK DOOR LOCKS EVERY DAY FOR PROPER OPERATION TO PREVENT INJURY OR DAMAGE.**
4. Disconnect power prior to servicing of machine.
5. This washing machine **MUST** be connected to a dedicated electrical circuit to which no other lighting unit or general purpose receptacle is connected.
6. **TO REMOVE TOP PANEL FOR SERVICE, remove two screws under soap supply box cover, holding panel to the supply box, before unlocking. Be certain to reinstall screws when remounting the top panel to prevent leaks from the supply box.**

MANUFACTURED BY ELECTROLUX-WASCATOR, LJUNGBY, SWEDEN
DISTRIBUTED BY WASCOMAT OF AMERICA, INWOOD, NEW YORK, USA
SOLD AND SERVICED BY INDEPENDENT WASCOMAT DEALERS

471 7446-01

LOCATED ON THE DOOR:

If you need to order more safety or warning signs, call Wascomat's parts department at 516-371-2000, or call your local dealer.

WARNING !

DO NOT ATTEMPT TO OPEN DOOR
UNTIL PROGRAM HAS FINISHED AND
DRUM HAS STOPPED ROTATING.

471 7651-17

Extract-O-Matic EX 12, EX 22

Contents

Introduction	1
Technical data	2
Installation	5
Electro-Lube Dispenser	12
Safety rules	15
Mechanical and electrical design	16
Card programming	33
Procedure	40
Maintenance	44
Trouble-shooting	45

The manufacturer reserves the right to make changes to design and material specifications.

Safety instructions

- **The machine is designed for water washing only.**
- **The machine must not be used by children.**
- **All installation operations are to be carried out by qualified personnel. Licensed personnel are necessary for all electric power wiring.**
- **The interlock of the door must be checked daily for proper operation and must not be bypassed.**
- **All seepage in the system, due to faulty gaskets etc., must be repaired immediately.**
- **All service personnel must be fully familiar with the operating manual before attempting any repair or maintenance of the machine.**
- **The machine must not be sprayed with water, otherwise short circuiting may occur.**
- **Fabric softeners with volatile or inflammable fluids are not to be used in the machine.**

Introduction

Fig. 1 The EX model washer/extractor has been developed to cover the heavy duty requirements of hotels, motels, nursing homes, hospitals, professional laundries, restaurants, airlines, steamships, schools, colleges and all on-premises laundries where flexibility and quick formula variation, coupled with high quality automatic washing, are required.

The washer extractor is controlled by a programmable card which allow complete programming of temperatures, water levels, wash periods etc.

The machines are free-swinging, i.e., the drum is moveable and spring suspended in relation to the frame. This minimizes vibrations transferred to the frame, thus simplifying installation, as no concrete base is required.

The high speed spin gives a G factor of approximately 300, providing very efficient water removal during the spin.

All parts of the machine which come into contact with the items being washed are made of heavy gauge surgical stainless steel, ensuring long life and lasting beauty, as well as full protection for no-iron fabrics. All electrical components are made accessible for servicing by simply removing the top panel.

This manual contains a technical description of the machine and instructions for its installation, operation and maintenance. Together with the wiring diagram which accompanies each individual machine it should be kept in a safe place for easy reference.

When ordering spare parts or contacting Wascomat for any purpose always give the machine serial number, model, voltage and other electrical characteristics appearing on the nameplate at the rear of the machine.

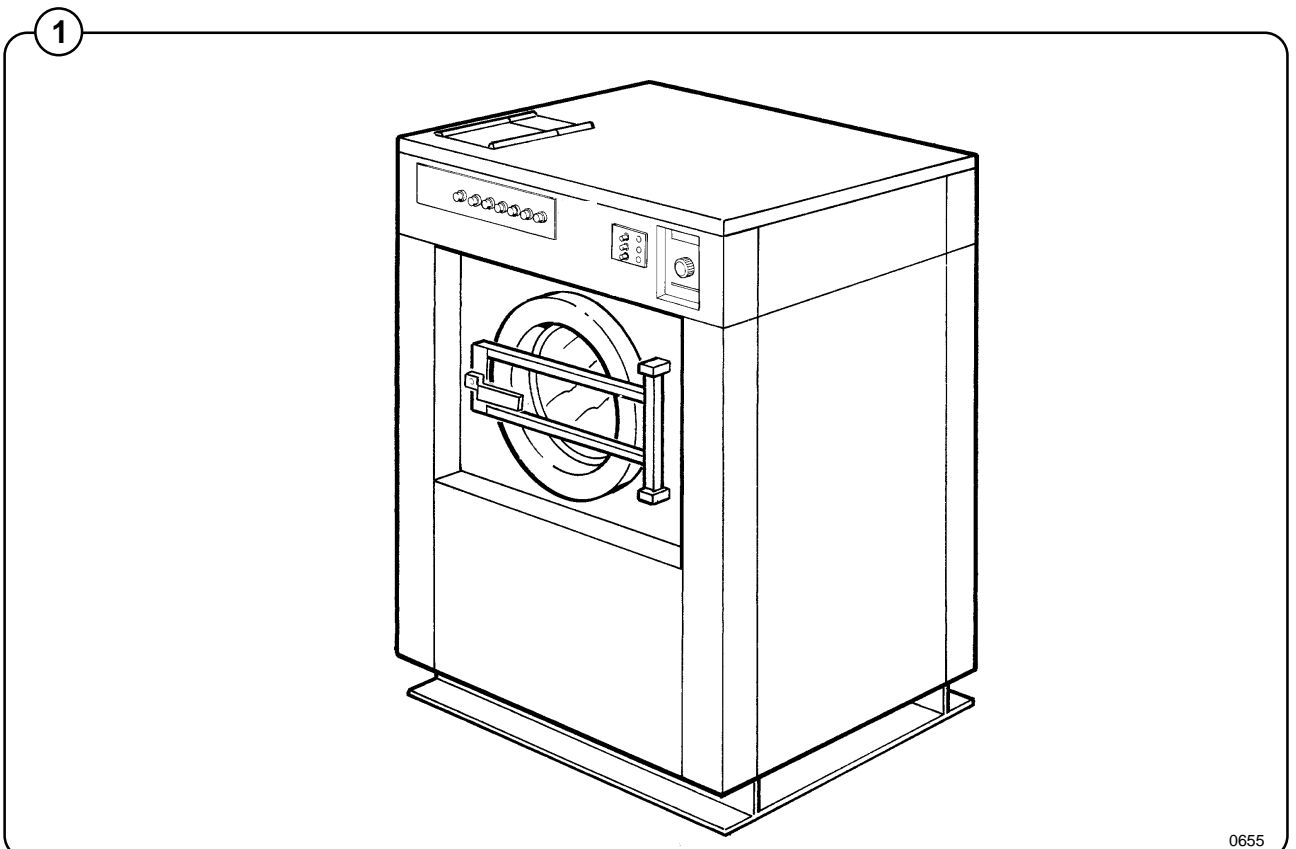

Technical data

EX 12

Dry load capacity	up to	13,5 kg	30 lbs
Overall dimensions	Width	870 mm	34 1/4"
	Depth	900 mm	35 15/16"
	Height	1302 mm	51 1/4"
	Net weight	290 kg	639 lbs
	Dyn.weight		120 lbs./sqft
Crated dimensions	Volume	1.25 m ³	44 cu.ft
	Weight	315 kg	695 lbs
Inner drum	Diameter	620 mm	24 7/16"
	Depth	412 mm	16 5/16"
	Volume	120 litre	4.4 cu.ft
Speed of rotation	Wash		48 r.p.m.
	Distribution		75 r.p.m
	Low extract		475 r.p.m.
	High extract		950 r.p.m.
G-factor	During wash		0.8
	During high extract		310
Motor speed	During wash		360 r.p.m.
	During high extract		3200 r.p.m.
Voltage requirements	Choice:		
		208-240 V 3-Phase 60 Hz	
		440 V 3-Phase 60 Hz	
Rated power	Motor, wash		250 W 0.35 HP
	Motor, extraction		1800 W 2.5 HP
Overcurrent protection	Three.-phase		15 A
Water connections			
Water pressure, max	10 kp/cm ²		142 psi
Recommended water pressure	2-6 kp/cm ²		25-85 psi
Hose connection, water	20 mm		3/4"
Hose connection, drain	75 mm		3"

EX 22

Dry load capacity	up to	22.5 kg	50 lbs
Overall dimensions	Width	1000 mm	39 3/8"
	Depth	1102 mm	43 3/8"
	Height	1412 mm	55 9/16"
	Net weight	553 kg	1218 lbs
	Dyn.weight		157 lbs./sqft
Crated Dimensions	Volume	2.05 m ³	72.3 cu.ft
	Weight	588 kg	1295 lbs
Inner drum	Diameter	750 mm	29 1/2"
	Depth	500 mm	19 11/16"
	Volume	220 litre	7.8 cu.ft
Speed of rotation	Wash		45 r.p.m.
	Distribution		67 r.p.m.
	Low Extract		425 r.p.m.
	High Extract		850 r.p.m.
G-factor	During wash		0.8
	During High Extract		300
Motor speed	During wash		540 r.p.m.
	During High Extract		3200 r.p.m.
Voltage requirements	Choice:		
		208-240 V 3-Phase 60 Hz	
		440 V 3-Phase 60 Hz	
Rated power	Motor, wash		410 W 0.55 HP
	Motor, extraction		2600 W 3.5 HP
Overcurrent protection	Three-phase		20 A
Water connections			
Water pressure, max	10 kp/cm ²		142 psi
Recommended water pressure	2-6 kp/cm ²		25-85 psi
Hose connection, water	20 mm		3/4"
Hose connection, drain	75 mm		3"

Outline and dimensions

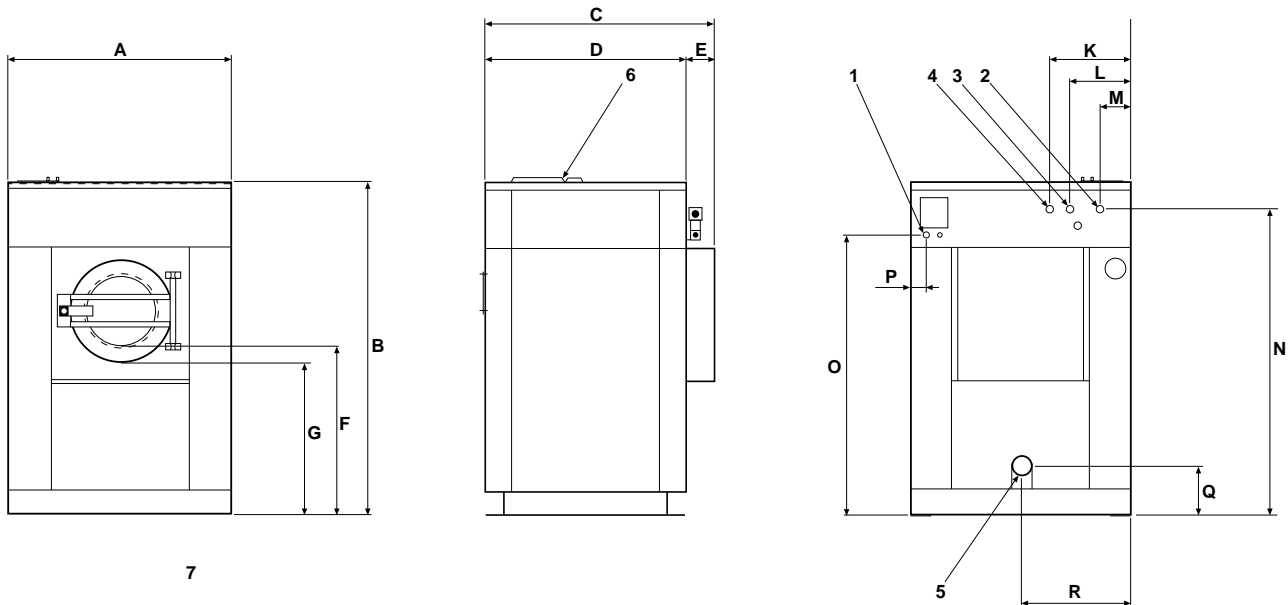

- 1 Opening for electrical cable connection
- 2 Steam connection (optional)
- 3 Cold water
- 4 Hot water
- 5 Hot water (only EX22)
- 6 Drain outlet
- 7 Soap box

2664

	EX12		EX 22	
	mm	inches	mm	inches
A	870	34 1/4	1000	39 3/8
B	1302	51 1/4	1412	55 9/16
C	913	36	1102	43 3/8
D	792	31 3/16	906	35 3/32
E	121	4 3/4	196	7 3/4
F	625	24 5/8	630	24 13/16
G	570	22 1/2	560	22
H	480	18 15/16	610	24
J	1100	43 5/16	1210	47 5/8
K	–	–	320	12 5/8
L	240	9 1/2	240	9 1/2
M	120	4 3/4	120	4 3/4
N	1200	47 1/4	1310	51 9/16
O	1110	43 11/16	1220	48
P	85	3 11/32	85	3 11/32
Q	203	8	203	8
R	433	17	498	19 5/8

Installation

The machine is delivered with expansion bolts and other items packed inside the drum.

Shipping securities

Fig. 2 The machine is shipped with four large metal bracket bolted to the four suspension legs as well as a support between the pulley and the back plate.

Prior to installation, follow these steps:

- Unpack the machine.
- Fig. 3 • Remove the lower front panel and the two rear panels.
- Remove the support from the pulley at the back of the machine.
- Remove both front brackets.
- Remove both rear brackets.

Placement

The machine should be installed close to a floor drain or open drain to make installation, use and service easier.

The following clearances are recommended for ease of installation and service:

- Fig. 4
- At least 20 inches between the machine and the wall behind it.
 - At least 2 inches on each side.

The floor must be able to support a static load of 790 lbs for the EX-12 and 1440 lbs for the EX-22.

The maximum impact load at extraction is 260 lbs force for the EX-12 and 480 lbs for the EX-22.

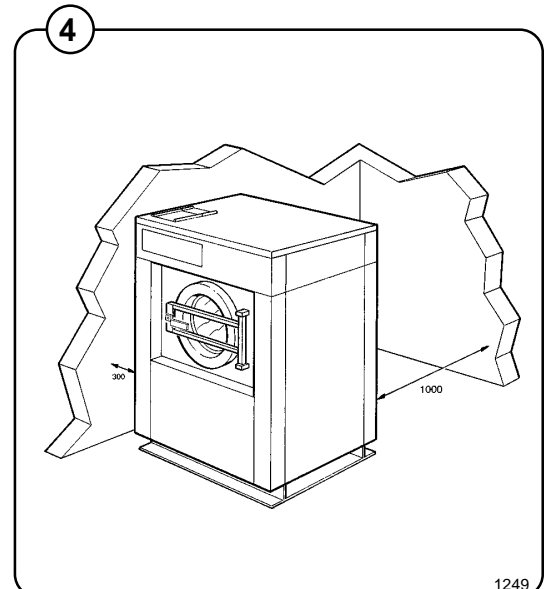
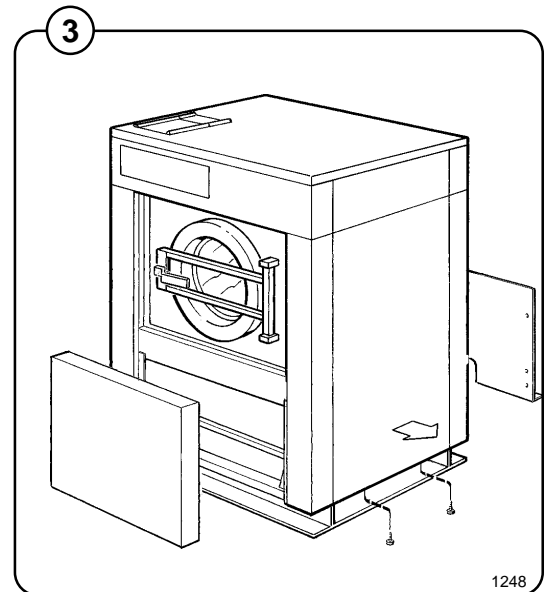
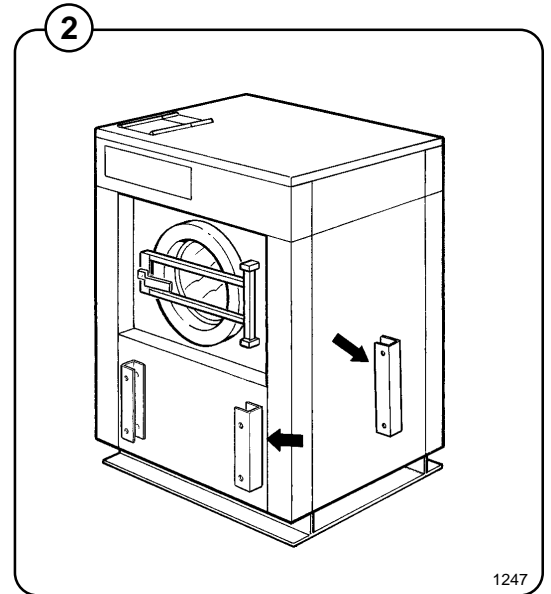

Mechanical installation

- Fig. 5
- Mark and drill two holes $\frac{3}{8}$ " in (8 mm) in diameter and approximately $3\frac{1}{2}$ " in. (90 mm) deep according to the dimensions in figure 5.
- Fig. 6
- Place the machine in position. Never lift the machine by the door or handle.
- Fig. 7
- Check that the machine is level and steady. Use stainless or galvanized washers between the machine and the floor.
 - Insert into the holes the expansion bolts supplied with the machine. Fit the washers and nuts.



It is of utmost importance that the machine is level, from side-to-side as well as front-to-rear. If the machine is not properly levelled, it may result in out-of-balance cutout without a real out-of-balance in the drum.



5

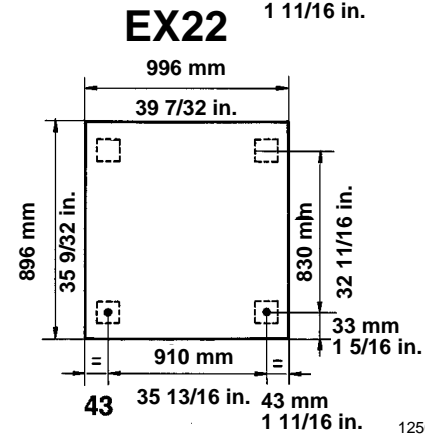
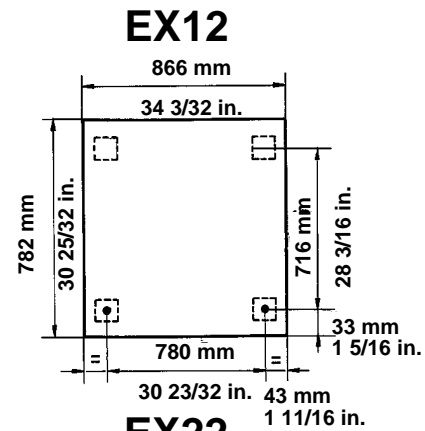

1250

6

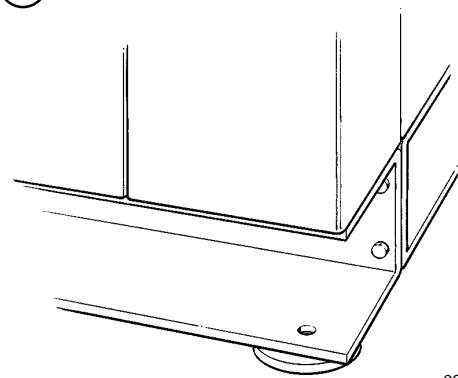

0620

7

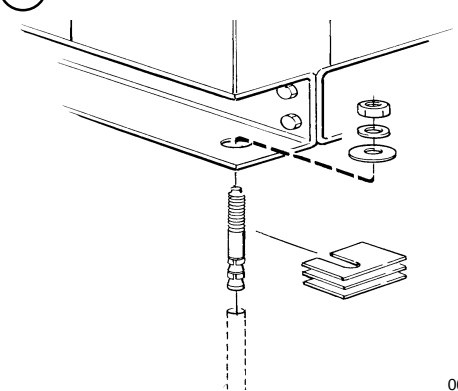

0621

Electrical installation

Fig. 8 Although the machines are fitted with thermal overload in the motor windings and separate fuse for the control circuit, a separate three-phase circuit breaker must be installed for all three-phase machines.

For proper overcurrent protection, check the data plate at the rear of the machine. Also consult local electrical code for special requirements.

Fig. 8 Connect L1, L2, L3 and ground wires according to the markings of the terminal block. The cable is to hang in a large loose loop, supported by the clip of the terminal block.

To ensure proper operation the drum must rotate counter-clockwise (seen from the front) during extraction. If the drum rotates in the wrong direction interchange line L1 and L3 at the power connection terminal.

Fig. 9 Check the incoming power for a high voltage leg. If present, connect that line to L2 on the terminal block.

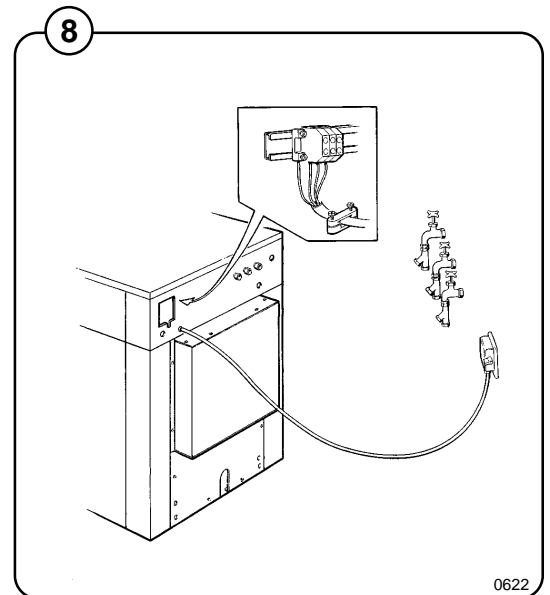

0622

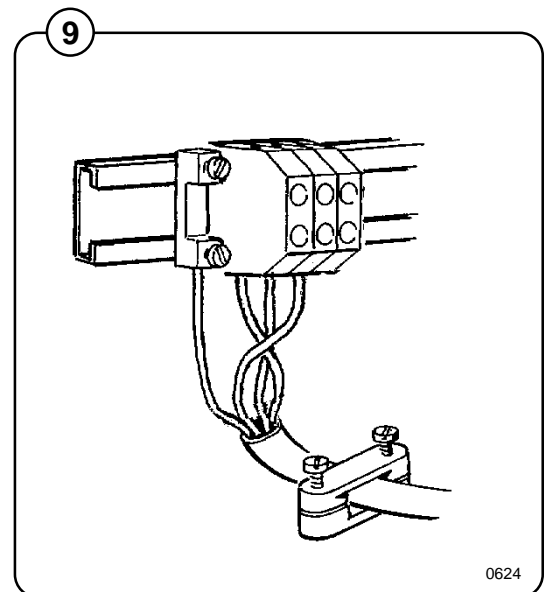

0624

Water connection

NOTE

All plumbing must conform to national and local plumbing codes.

Fig. 10 Incoming water lines do not require non-return valves, as the machine is already fitted with a siphon breaker. However, all incoming lines must be fitted with shut-off valves and strainers.

Fig. 11 • Water inlets are labelled for hot and cold water connection.
 • Flush the water system thoroughly and check that the strainer at the machine inlet is fitted correctly.

Fig. 12 • Connect the machine to the water mains with 3/4" reinforced rubber hosing not to exceed 6 ft in length. Hang the hosing in a large loop. Do not use rigid piping.

Drain connection

Fig. 13 Connect a 3" (75 mm) flexible hose to the drain outlet of the machine.

The drain house must not have any sharp bends and must slope from the machine to assure proper drainage. The outlet must open freely to the main drains.

Do not reduce the size of the drain connection from the machine to the waste line.

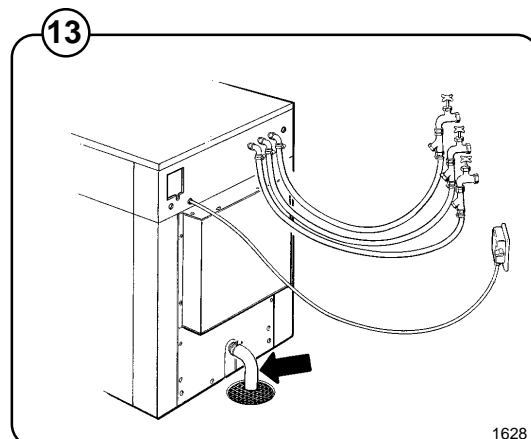
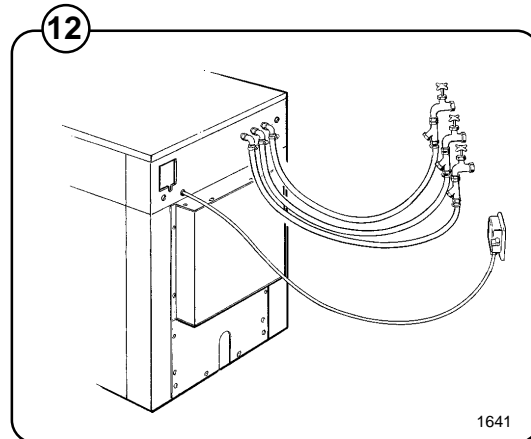
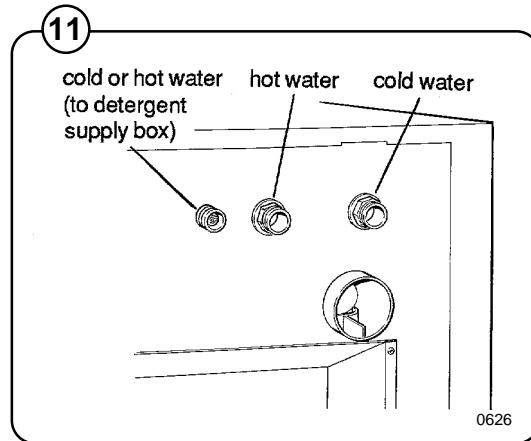
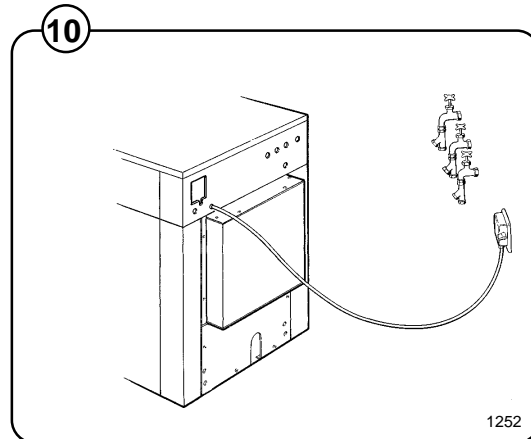

Connection of external liquid supply

Remove cover and cover support over the soap box.

Fig. 14 Bend all the way back the metal plate in compartment 3.

Fig. 15 Pull the knobs up and forward.

- Fig. 16
1. Loosen both knobs so that one side of the metal fingers underneath can slide under the top lid of the machine, within the supply box.
 2. Fit the supply injector into the supply box so that both sides are held securely in places by the metal fingers.

Note:
 If the supply injector does not fit turn it around. You have it in backwards.

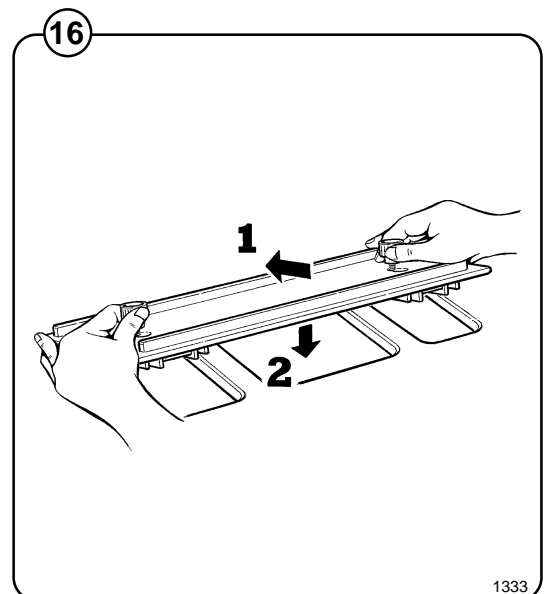
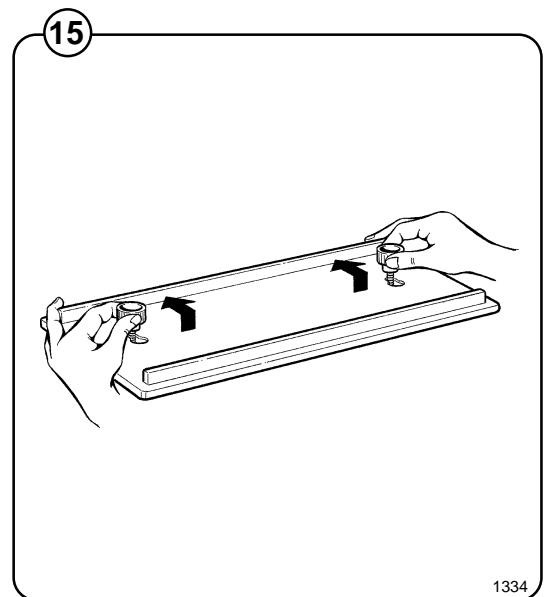
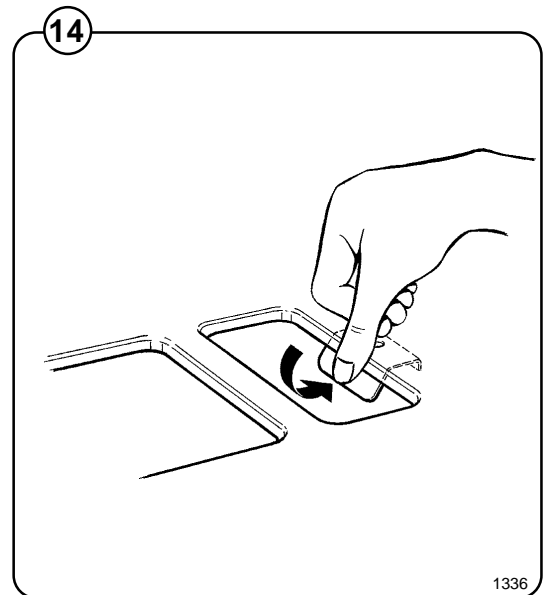

Installation

- Fig. 17**
1. Drop the knob into the larger opening in the supply injector lid.
 2. Tighten securely. Do not overtighten! Do not use pliers or other tools to tighten the knobs!

- Fig. 18**
1. Stretch the multi-rubber ring B and select the correct size ring which will fit snugly on the chemical tube you are using. Ring A is used for tubes with $\text{\O} 1/3''$ (8 mm).
 2. Use scissors or a razor to carefully cut out the proper size rubber ring. Wrap the rubber ring around each tube after threading each tube through the plastic nipple. Run the tube through the compression nut to the bottom of the compartment. Cut the end of the tube at an angle. Hand tighten the plastic nipple on to the compression nut.

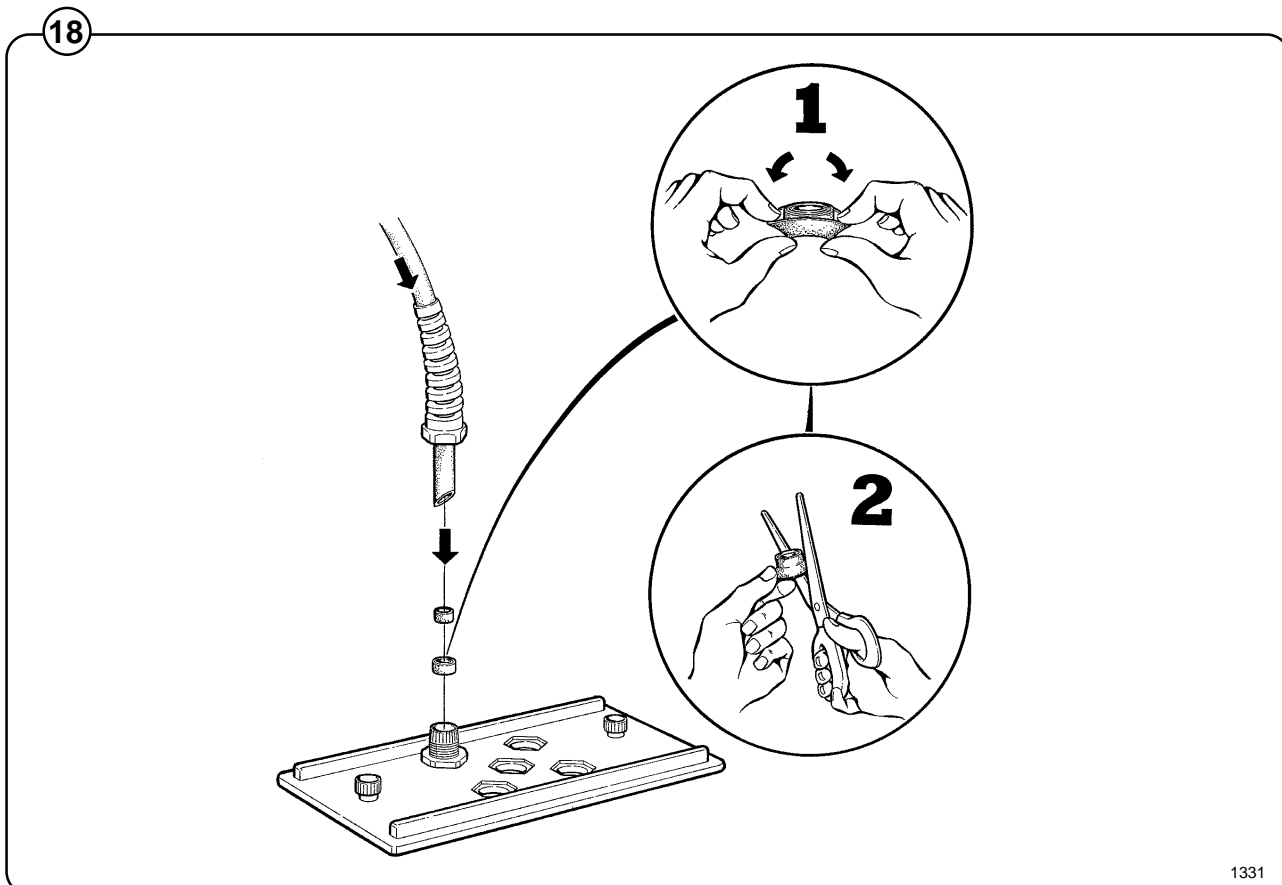
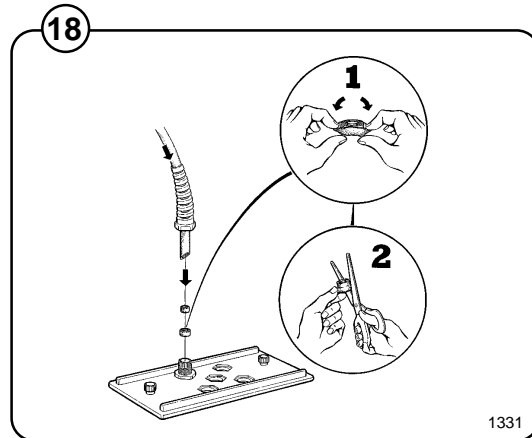
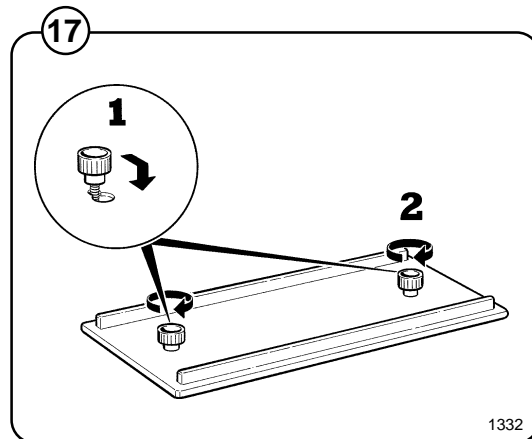

Electrical connection

Fig. 19 At the rear side of the control unit are two quick connectors. When the machine is delivered connector A is connected. When using powder supply, change to connector B.

Pump connection

Fig. 20 To the right of the incoming power terminal connection block is the connection for pumps. Depending on the number of pumps to be connected, they shall be connected from 1-5 and C (common) on resp. connection. The pumps obtain signals from the timer.

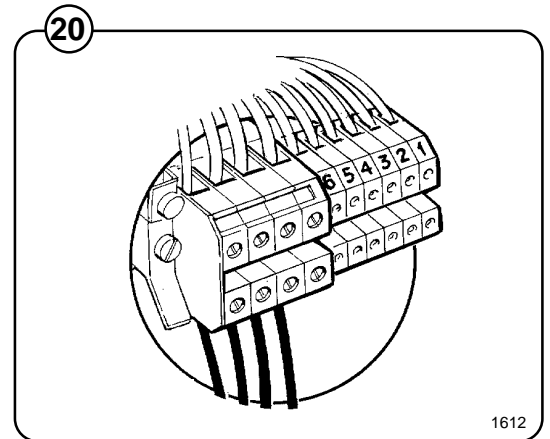
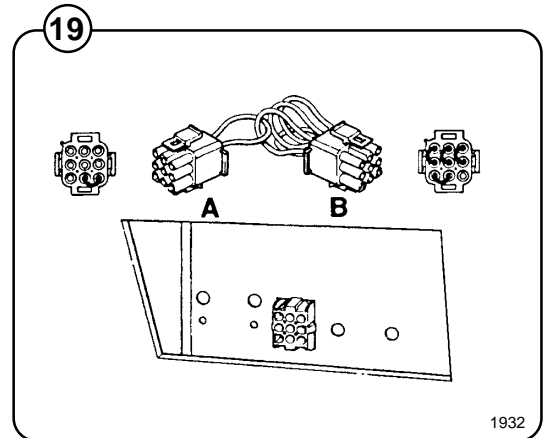

Instruction for setting timing on electro-lube oil dispensing

Fig. Pry off the switch panel cap with a screwdriver.

21 Fig. Under the cap are the switches for time setting.

22 Fig. Set the "Light" and "12M" dip switches to the "On" position. Make certain all other switches are in "Off" position.

23 Fig. The light will start flashing after a few minutes and will continue to flash every 15th to 20th seconds as long as the dispenser is in operation.

24 Fig. The decal shown below should be affixed at the front of the machine and updated as required.

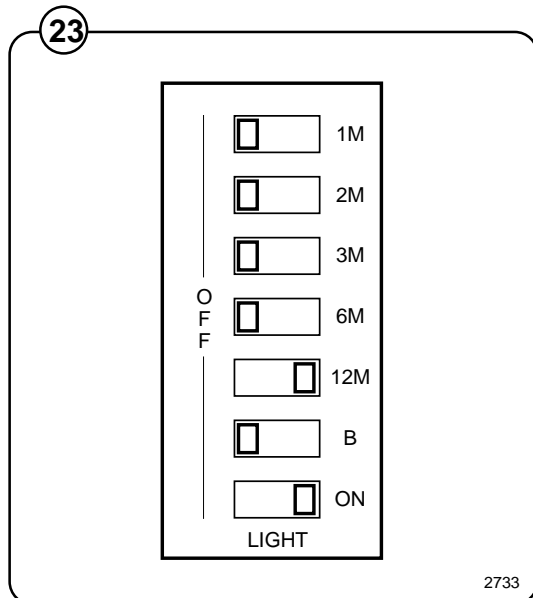
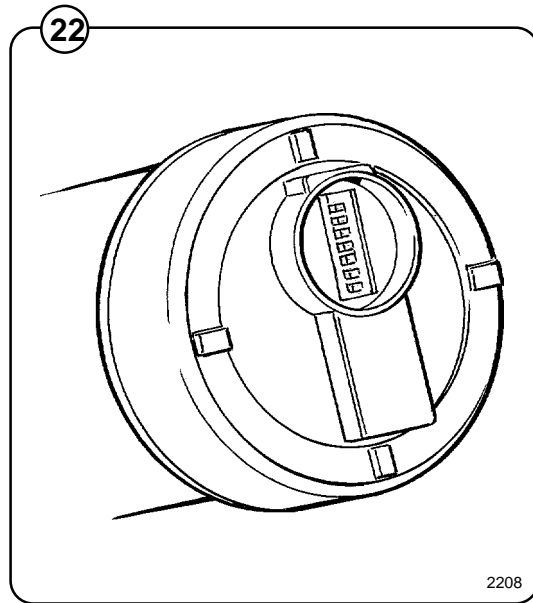
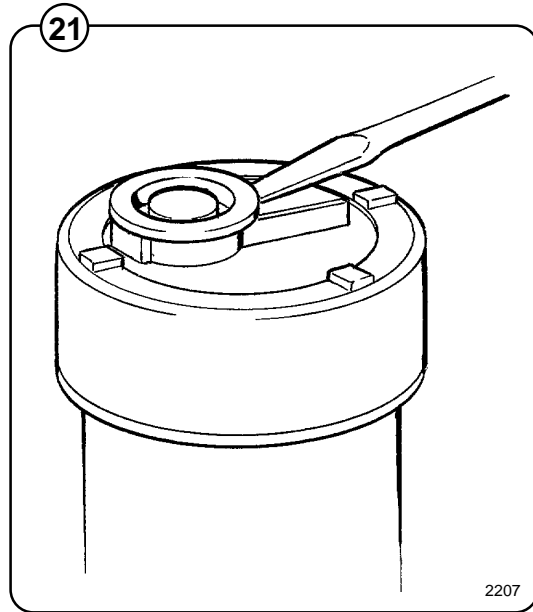

IMPORTANT NOTICE

This machine is equipped with an automatic oiler, located at the right rear of the machine, which keeps it lubricated for long bearing and seal life. The amount of oil in the container is sufficient for approximately one year's lubrication. It is of utmost importance that the oiler does not become empty. Therefore we recommend that the rear panel to be removed and a visual inspection to be made on a bimonthly basis. When the oil reaches a low level, the cannister must be replaced with a new one available from Wascomat as Part No. 827601.

Date Last Replaced	Date Last Replaced

Start-up and safety checklist

Before initial start-up of a Wascomat washer-extractor, the following safety checks must be performed:

- Fig. 25
- Make sure that all electrical and plumbing connections have been made in accordance with applicable local codes.
 - Use only flexible water fill and drain hoses of the proper length to avoid sags and kinks.
 - Make sure the machine is properly grounded electrically.

Before the machine is operated, the door safety interlock must be checked for proper operation as follows:

- Fig. 26
- When washer loading door is open, the machine must not start. Verify this by attempting to start washer with door open.
- Fig. 27
- When washer is in operation, the loading door is locked and cannot be opened. Verify this by attempting to open the loading door when the machine is operating. If necessary, consult this manual for proper operation of the door lock and door safety interlock or call a qualified serviceman.

IMPORTANT:
 Door safety interlock must be checked daily in accordance with above procedure.

WARNING:
 Before servicing Wascomat equipment, disconnect electrical power.

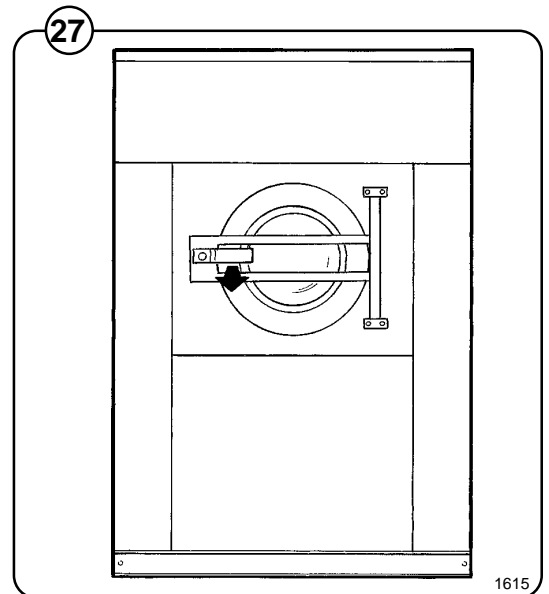
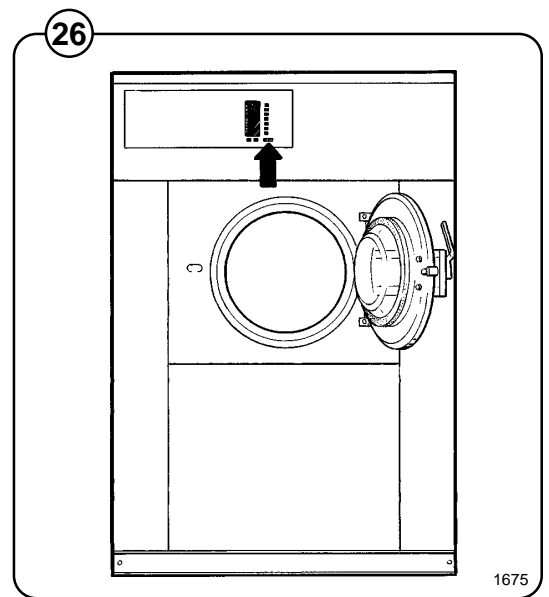
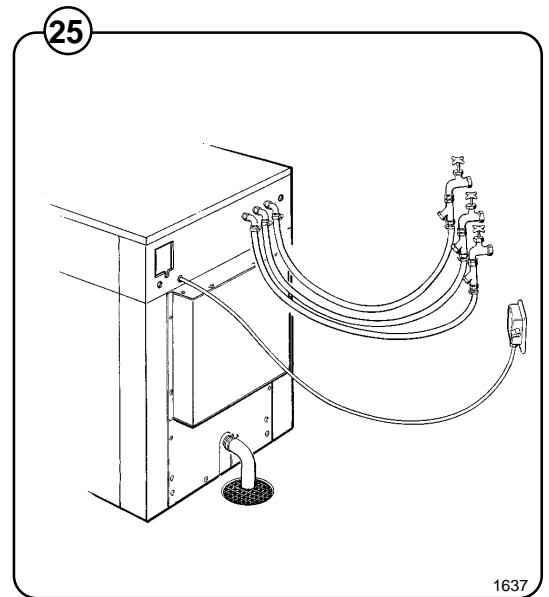

Function control check-out list

In the machine cylinder, you will find the warranty registration card, a copy of the warranty policy and other pertinent material.

The warranty card should be completed and sent to Wascomat. All other items should be placed in a safe place for future reference.

The machine should be cleaned when the installation is completed, and checked out as detailed below without loading the machine with fabrics:

1. Check the incoming power for proper voltage, phase and cycles.
2. Open manual shut-off valves to the machine.
3. Turn on electric power.
4. Check the door safety interlock as detailed on page 9 of this manual.
5. Run through a complete cycle, checking for water temperature, drain operation and the extract function. For operating instructions, see the section marked "Procedure".

Fig.

28

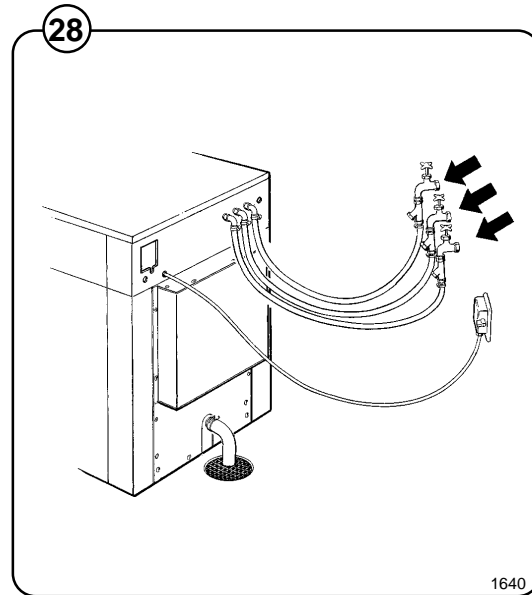

NOTE

All machines are factory tested prior to shipment. Occasionally, some residual water may be found when the machine is installed.

Safety rules

- **This machine is designed for water washing only.**
- **Machines must not be used by children.**
- **All installation operations are to be carried out by qualified personnel. Licensed personnel are necessary for all electric power wiring.**
- **The interlock of the door must be checked daily for proper operation and must not be bypassed.**
- **All seepage in the system, due to faulty gaskets etc., must be repaired immediately.**
- **All service personnel must be fully familiar with the operating manual before attempting any repair or maintenance of the machine.**
- **This machine must not be sprayed with water, otherwise short circuiting may occur.**
- **Fabric softeners with volatile or inflammable fluids are not to be used in this machine.**

General

Fig. 29 This machine is a free-swinging model i.e. the outer drum and motor bridge are suspended in the machine chassis via a spring suspension with a strong spring in each corner of the machine. Each spring has a shock absorber which dampens the movement of the machine.

The inner drum is driven by two motors via a V-belt: one motor for washing and distribution speed and one for extract speed. The inner drum is mounted in the outer drum with two heavy duty bearings at the back plate and is sealed with two V-rings.

The two motors are suspended underneath on a motor support with a belt tensioning device. The motors are mechanically coupled to each other with V-belts. During wash and distribution speed the spin motor transmits power to the drum, through a clutch arrangement.

The water inlet and drain are both situated under the outer drum. This improves the flow during filling and prevents water vapour from entering the detergent compartment.

The robust square door is locked with a handle which is interlocked by a safety device when the machine is running.

The manual push buttons and card programmed control are fitted at the front of the machine.

All control and indicating components i.e. relays, delay unit, etc. are assembled under the top cover, easily accessible from the top of the machine for simplified servicing.

The machine housing consists of hot-dip galvanised, painted steel plates and stainless steel sheets, painted on the front and sides. It has a stainless door (and front, on request).

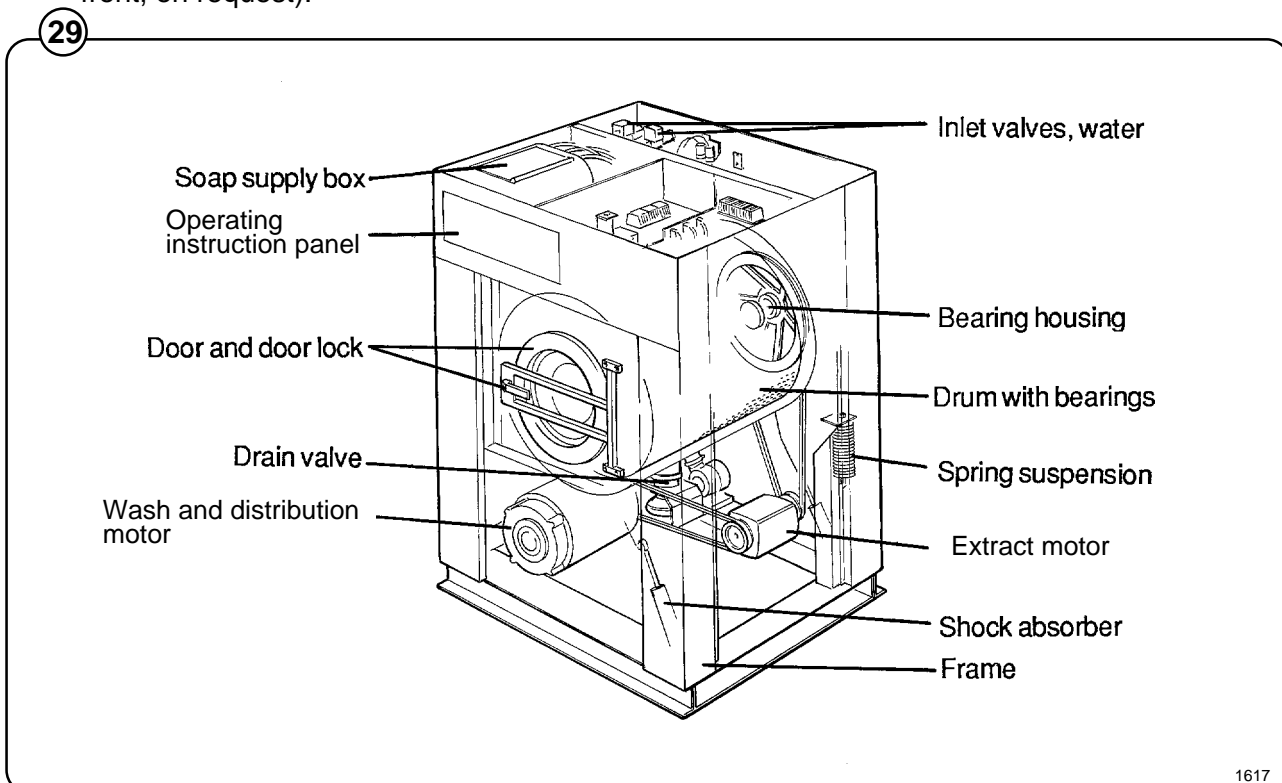

Frame

Description

Fig. 30 The frame is constructed on the free-swinging principle, i.e. the washing drum is freely and resiliently suspended in the fixed frame.

The entire frame is constructed of U-shaped iron beams forming a stable and torsionally rigid structure.

The suspension device for the drum unit and motors consists of four posts, one in each corner, each with a robust spring to which the washing drum supports are attached. In order to prevent excessively great vibrations which can be caused by imbalance in the drum, a shock absorber is fitted between the drum and frame by each spring. (The EX-12 model has twin shock absorbers at the front.)

Repair instructions

If the out-of-balance cutout is repeatedly triggered

- Check the shock absorbers, replace them if required. Note that the shock absorbers should be fitted with the plunger rod upwards.
- Check the attachment of the springs:
 - the spring is attached by a bolt from above: Check that it has been properly tightened down.

The entire spring unit should be replaced in spring replacement.

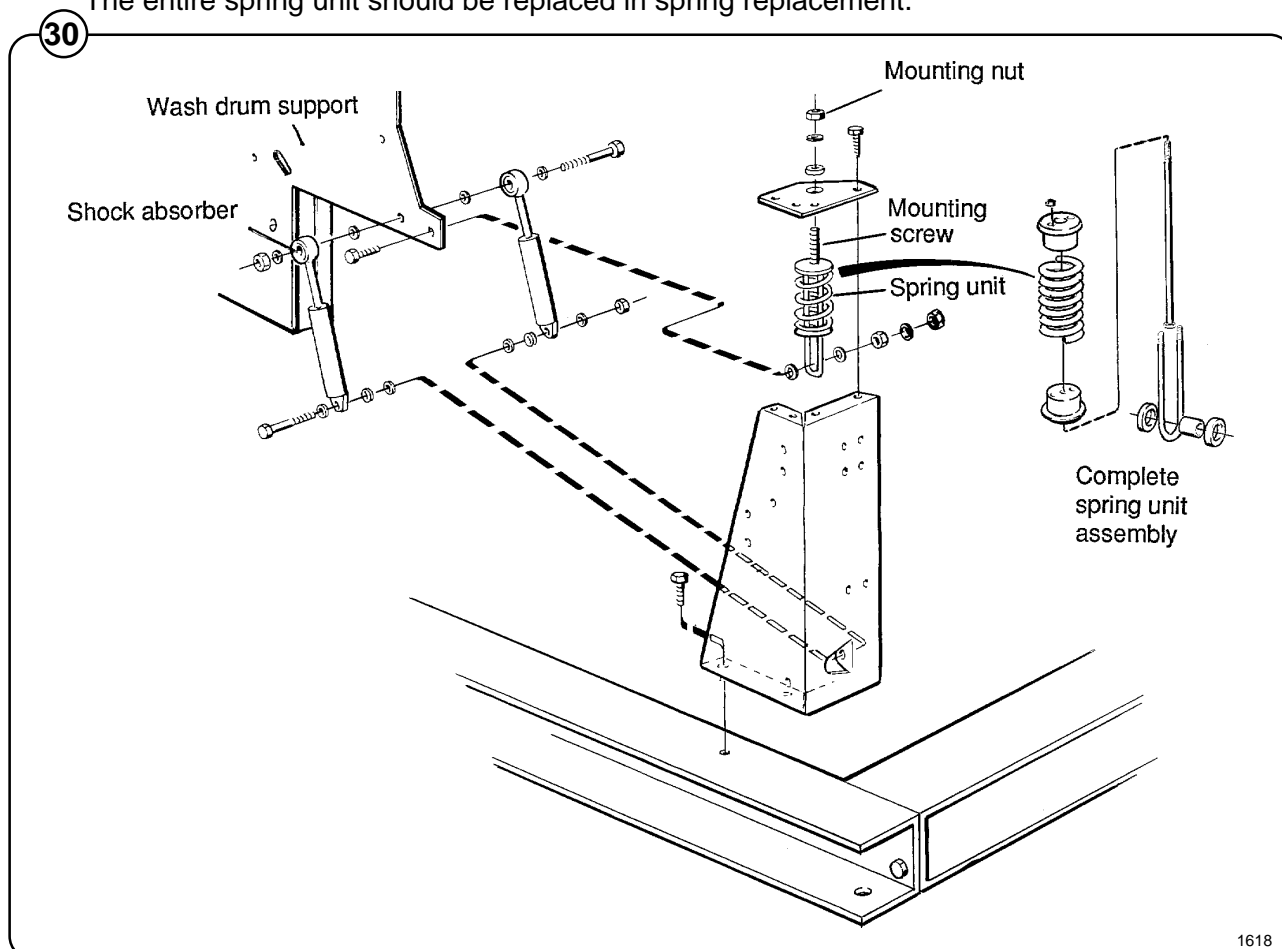

Drum with bearings

Description

Fig. 31 The inner drum is journaled to the outer drum by two robust bearings in a bearing housing which is bolted to the rear plate. The bearing unit supports the drum without any support being needed at the front. Shaft seals of the V-type, as well as O-rings, seal against leakage.

The space between the bearings is packed with grease during assembly. No additional grease is required.

The inner drum shaft is continuous, and the V-belt pulley is attached to the protruding journal by an adapter sleeve.

The outer drum end plate consists of two parts, the inner and outer end plates which are bolted to the bearing housing with through bolts. **NOTE:** The inner and outer end plates must not be taken apart when the bearings are replaced.

The outer drum and rear plate are held together by 3 straps.

The outer drum is connected to its resilient suspension by four supports, bolted to the end plates. It is important that these supports are not loosened from the rear plate during repairs.

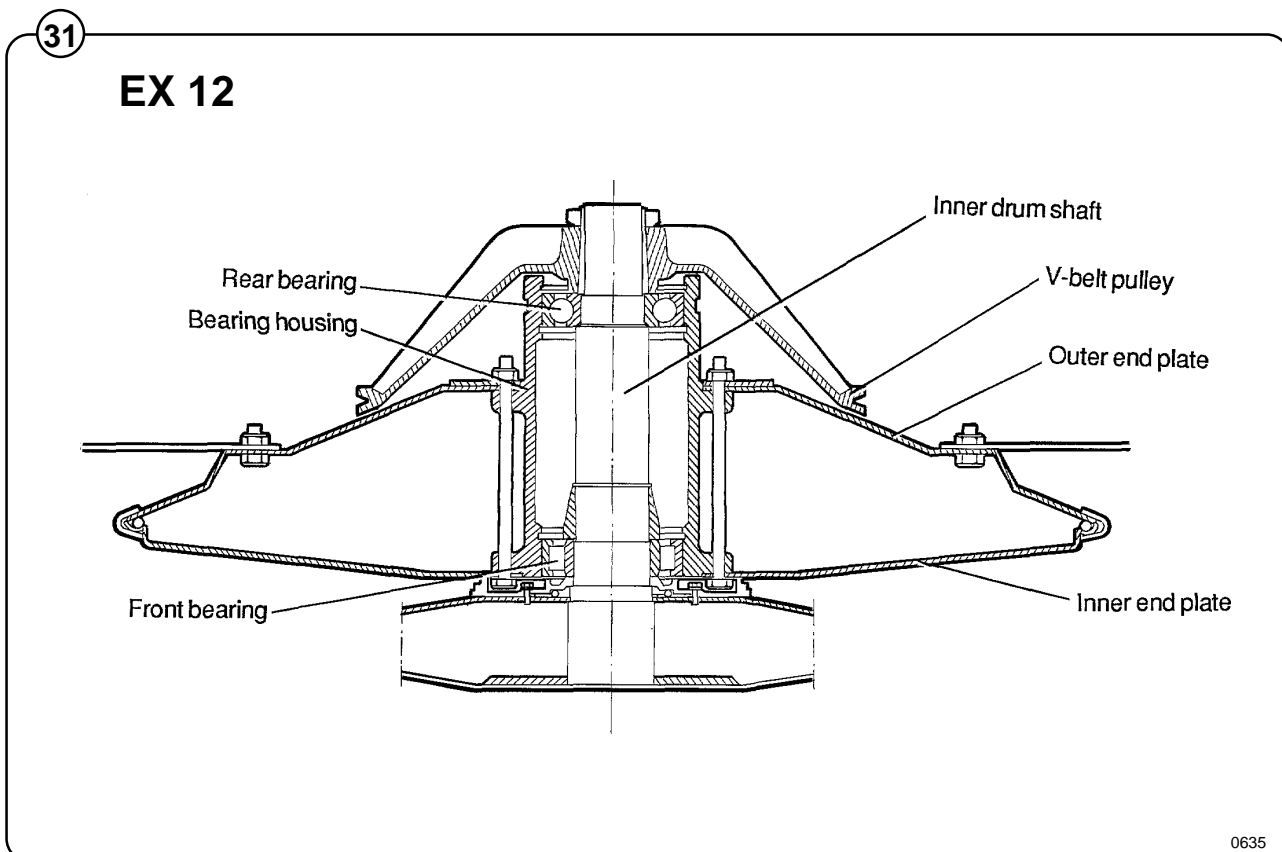

Safety locking device

Description

Fig. 32 The machine safety locking device includes a safety interlock system which prevents personal injury through the following precautions:

- The machine cannot be started until the door is shut.
- The door is automatically locked when the machine starts.
- It is not possible to open the door until 2-3 minutes have elapsed after the washing program has ended. This ensures that the drum is motionless when the door is opened.

Repair instructions

If the coil does not lock the door:

- Check that the coil is receiving 100-110 V DC. Measure the coil to determine if there is an interruption.
- Check that the armature of the coil is not stuck.
- If necessary, replace the entire coil.

Other possible faults:

- Faulty microswitch.
- Faulty delay circuit.
- Moving parts jammed.
- Handle not in locking position.

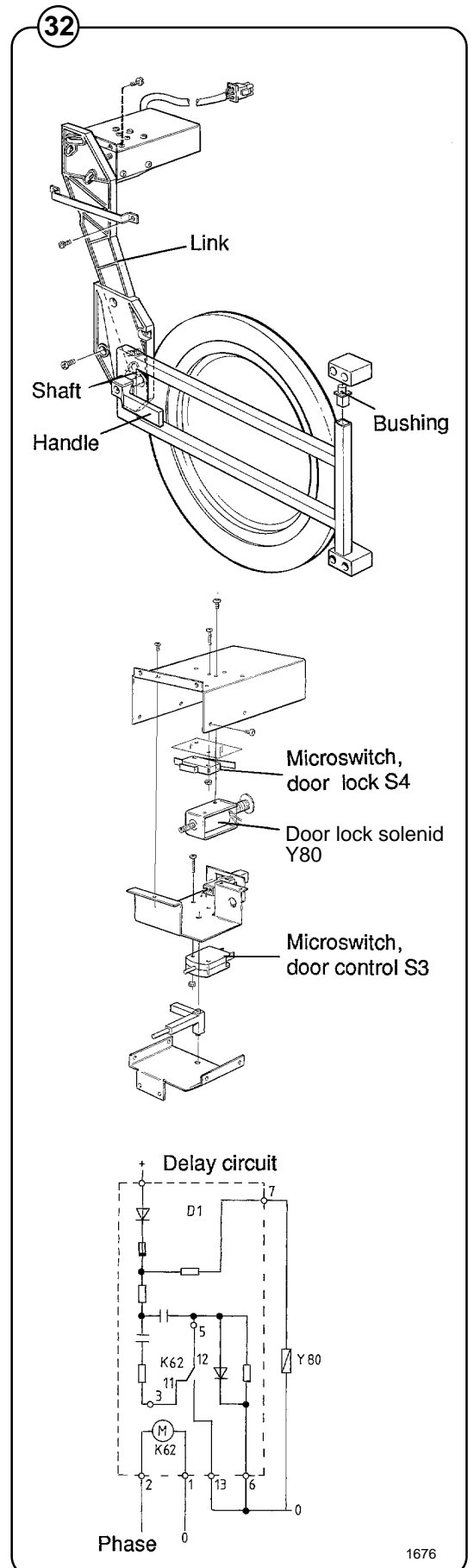

Function

If the machine has not been energised within the last three minutes, the door will remain unlocked. When the machine is energised the door will be locked if a program is activated or if the drum is rotating. Upon completion of a program the door will be unlocked automatically as soon as the drum has stopped rotating.

If the power supply is cut to a machine which was energised the door will remain locked for three minutes, after which time it will be unlocked automatically.

Fig. The diagram below shows how the delay unit works.

33 When the machine is energised the delay unit is fed phase and neutral on X194:5 and X194:4 respectively. The door lock coil Y80 is then fed phase (via a normally closed relay contact) and neutral from X194:3. The relay coil acts on two conditions – that the drum is at a standstill and an "open" signal from the programmer circuit board:

- One side of the relay coil receives a zero potential signal when the rotation guard short-circuits X193:1 and 2.
- The other side of the relay coil is supplied with phase from the programmer circuit board ("open" signal).

Both of these conditions must be fulfilled for the door to be unlocked.

In the event of a power cut the capacitor will discharge via the relay and the door lock solenoid. In this way the door lock solenoid continues to operate for three minutes, after which the door is unlocked automatically.

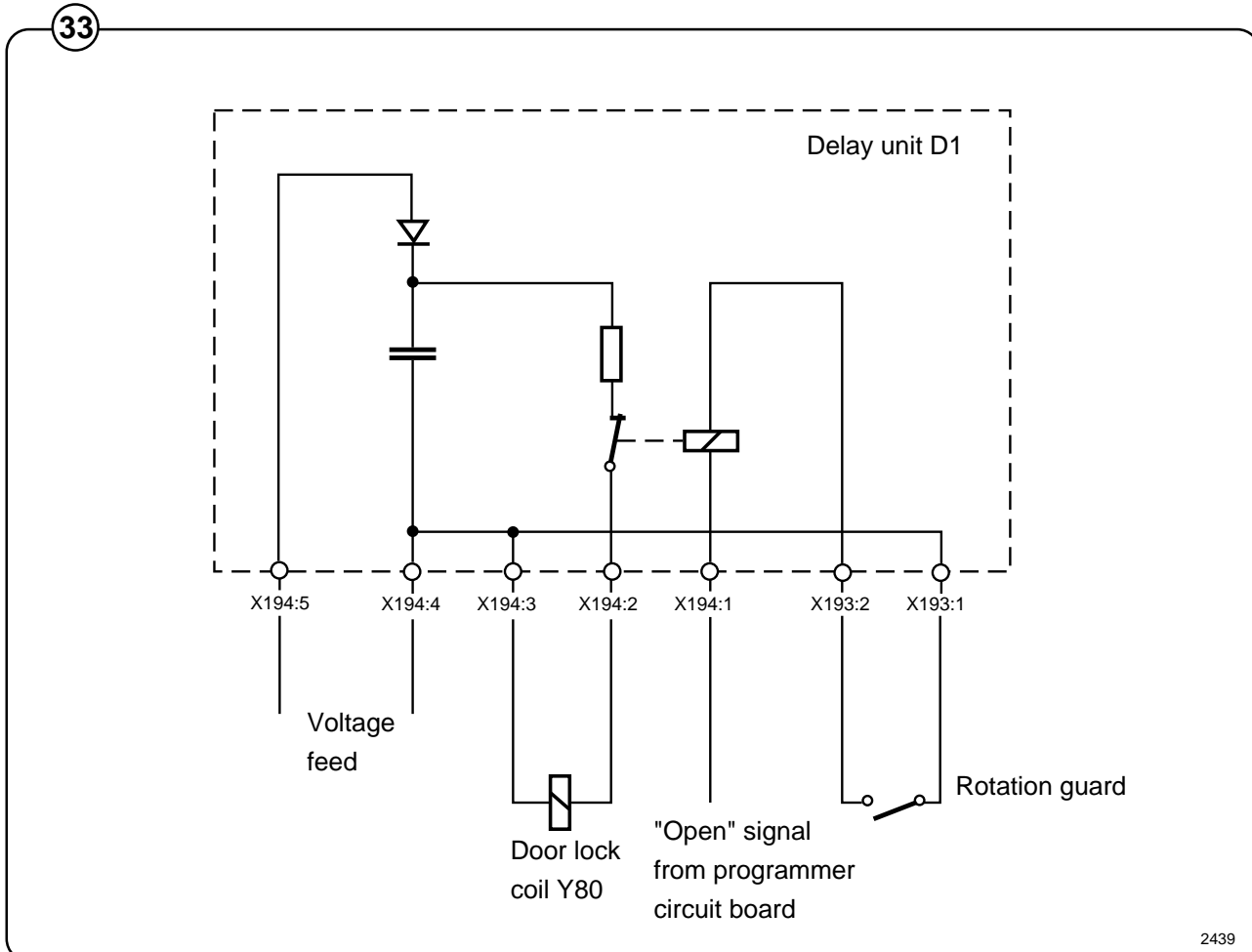

Fault location

Door does not unlock

Conditions: wash program ended and drum at a standstill.

Measure the voltage between the following points:

1. **X93:2 - X93:3** Should be 0 V DC. If the voltage is 220 V AC, check the rotation guard.
2. **X193:1 - X193:2** Should be 0 V DC. If the voltage is 220 V AC, check the rotation guard and the cables between rotation guard and delay unit.
3. **X194:1 - X194:4** Should be 220 V AC. If not, the "open" signal from the programmer circuit board is absent. Check pcb and cables between pcb and delay unit.

If the door is still locked, replace the delay unit.

Door does not lock

Conditions: door closed and wash program activated.

Measure the voltage between the following points.

1. **X194:1 - X194:4** Should be 0 V AC. If the voltage is 220 V AC, the programmer circuit board will constantly send the "open" signal. Check pcb and cables between pcb and delay unit.
2. **X194:2 - X194:3** Should be 200 V DC.
 - If there is no voltage, replace the delay unit.
 - If this voltage is present, check the door lock coil and its cables.

Rotation guard

Description

Fig. 34 The rotation guard checks that the machine is completely at a standstill before the door can be opened. When the drum has been at a standstill for approx. two seconds the solenoid in the door lock is deactivated and the lock can be opened (provided that the machine has been emptied of water and the programmer has reset). The rotation guard also checks that the drum is revolving when the wash or extraction relays are operating.

The rotation guard consists of a circuit board in the automatic control unit and a sensor in a holder on the machine rear. There is a magnet on two of the spokes of the pulley. Each time a magnet passes the sensor, a contact closes inside the sensor and it relays a pulse to the rotation guard.

When the machine is at a standstill the rotation guard relays K1 and K2 are closed, which means that the delay unit and the HI-TEK receive confirmation that the drum is not moving, i.e. the rotation guard and the HI-TEK allow door opening.

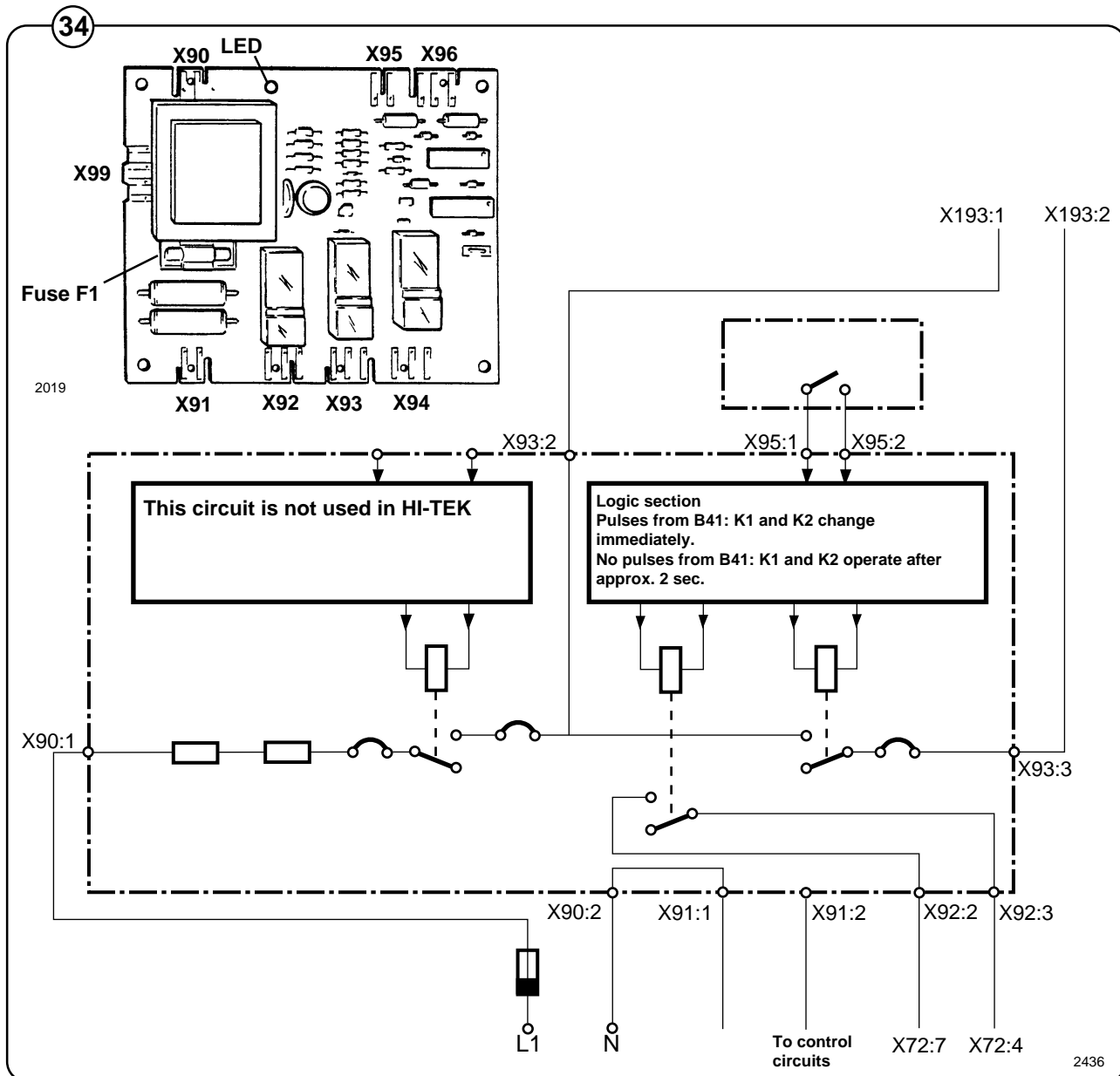

Control unit

Fig. 35 The control unit is mounted under the top panel in the machine.

In the unit are the following components:

- 2-8 Push buttons for manual control.
- 2 **ON/OFF** Push button, main supply switch for the machine.
- 3 Restart push-button switch. When stop is programmed the switch lights up and buzzer goes on. When the switch is depressed the program will continue from where it stopped.
- 4 Switch for selecting **GENTLE ACTION**.
- 5 Switch for opening **DRAIN**.
- 6 Switch for filling **HOT WATER**.
- 7 Switch for filling **COLD WATER**.
- 8 Switch for flushing **DETERGENT** from compartment 1.
- 9 Delay unit keeps the door locked appr. 2-3 min. after the program is finished.

35

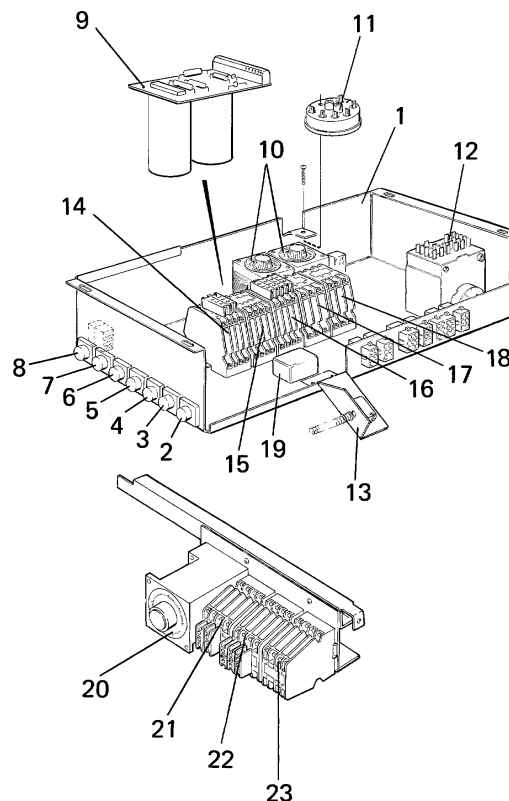

- 10 Time delay relay for drain.
- 11 Level switch for high and low level in the drum. For steam and electrical heated machines, the switch is also controlling that there is water in the drum before the heat comes on.
- 12 Reverser giving start impulses for functions such as reversing, gentle action, etc.
- 13 Out of balance switch which stops the machine if there is too much unbalance when the machine goes into extraction.
- 14 Relay for out-of-balance function.
- 15 Relay for restart.
- 16 Relay for drain.
- 17 Relay for wash speed.
- 18 Relay for distribution speed.
- 19 Buzzer
- 20 Time delay relay for extraction.
- 21 Extract relay low speed.
- 22 Extract relay high speed.
- 23 Extract relay high speed.

Relays

The EX 12 and 22 models employ eight relays.

Construction

Fig. 36 The body of the relay holding the stationary contacts is made of current-resistant plastic. A solenoid and a contact bank hold the moving contacts. The contacts are spring-loaded to assure the correct contact pressure.

The relay is constructed for continuous operation, whether mounted horizontally or vertically.

Screw-type terminals provide perfect connections even when one or two wires have different diameters.

Operation

When the solenoid is energized, the two halves of the magnet core are drawn together, pulling down the moving contacts, thus making or breaking the circuit. When the current cuts out, springs force the contact bank into its original position, thus closing or opening the circuits.

Trouble shooting

If the relay fails to operate despite power to the coil, turn off the power and check the solenoid by measuring the resistance across the terminals (1).

If the relay hums when power is applied, this indicates either a break in the insulator holding the moving contacts at the axle where it holds the top half of core (3) or a rusty core (4), which can be cleaned.

Make sure that the moving contact assembly (4) moves freely. Always replace burnt or pitted contacts (2)... do not reuse contacts.

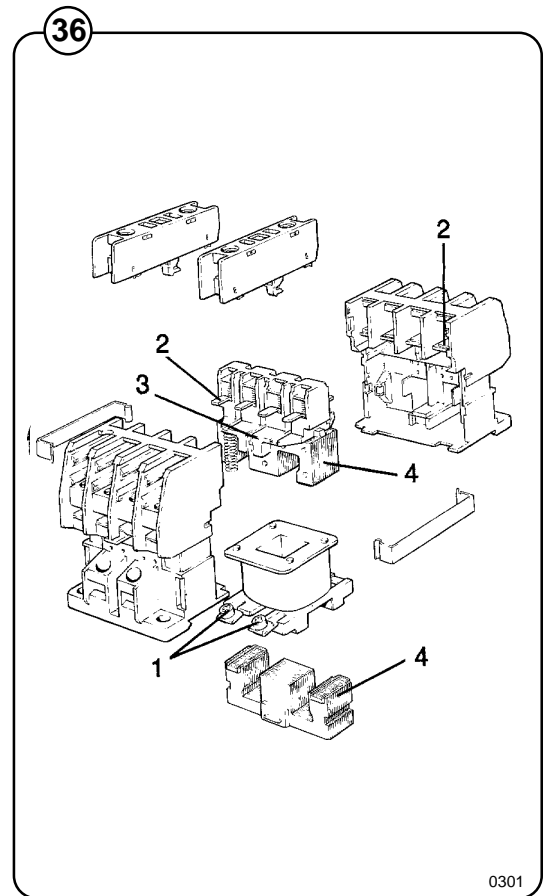

0301

Drive motors

Description

Fig. 37 Both motors, one for wash and distribution and one for extraction, are installed on the same motor bridge. The motors drive the drum and are mechanically connected to each other by V-belts. On the EX 22 there is also an electromechanical clutch. The motors rotate at each others' speed during the wash speed, distribution speed and low extraction speed.

During high extraction speed the speed control on the EX 22 gives a signal to the electromechanical clutch. This disconnects the motors from each other mechanically. The wash motor now rotates at distribution speed and the extract motor at high speed.

On the EX 12 the power supply to the wash motor is disconnected by the speed control.

On the motor bridge there are belt tensioning devices. The extract motor is screwed to a mobile plate which moves via oblong holes in the motor bridge. This is used to tension the belt drive between the motors. It is possible to tilt the entire motor bridge with the use of the oblong holes on the wash motor side. This is used to tension the V-belt up the wash drum.

Fig. 38 The motors are equipped with thermal protectors which are placed in the stator coil. In the case of overheating in the motors, i.e. if the temperature exceeds 130°, the protector contacts cut the power to the motor relays.

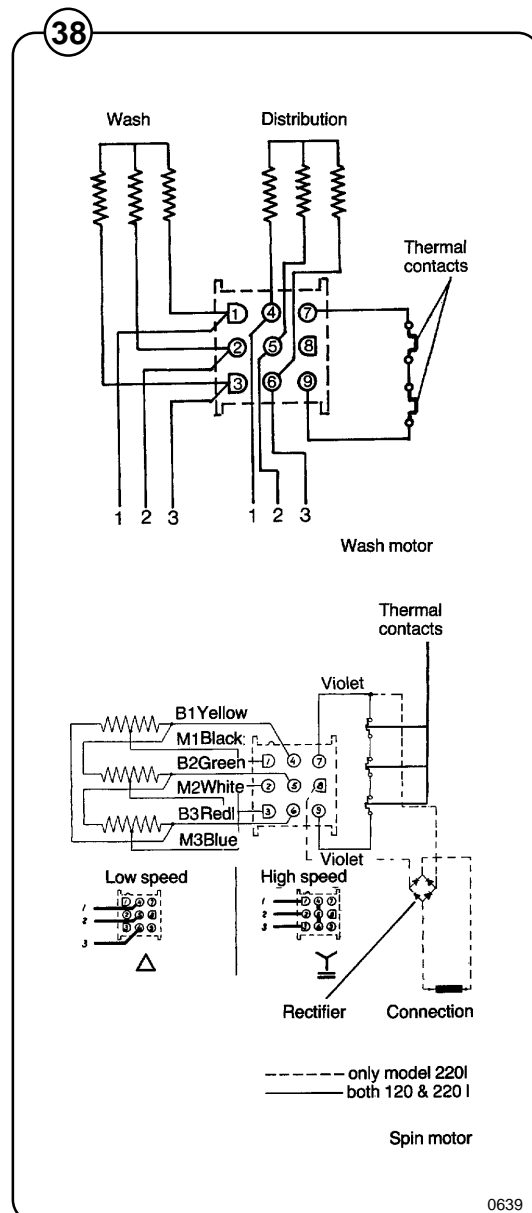
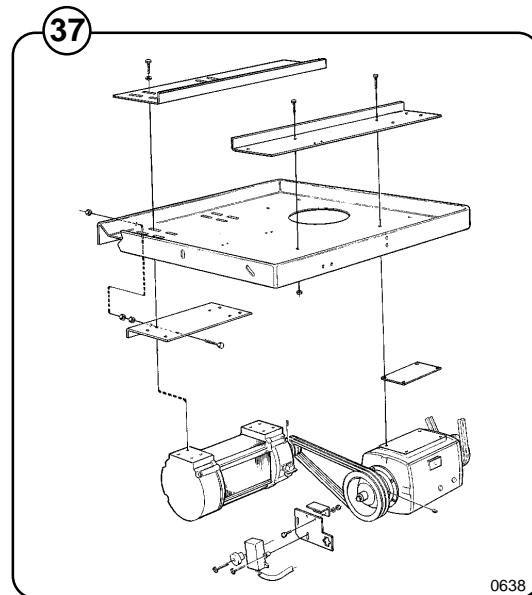

Repair instructions

Overheated motor, motor not running

- Wait till motor has cooled down. Motor thermal protectors are automatically reset after appr. 30 minutes. Restart.
- Possible cause of motor protector releasing repeatedly could be oversensitivity of thermal protector.

Very noisy motor

- Breakdown of bearings - replace bearings or motor.

Motor running slowly

- The motor is probably running on two phases - measure coils on terminal.

Wash motor only runs at one of the speeds

- Check that the quick connection is correctly connected.
- Measure coils at connector, as the fault can be caused by interruption in one of the coils.

Motor locks

- Breakdown of bearings - replace bearing or motor.

Motor does not turn

- Check belt tension.

Tensioning of the V-belt

- Fig. **39**
- Belt between the wash motor and extract motor
 - release and adjust backing plate to correct belt tension according to illustration. Fasten plate.
 - Belt between extract motor and drum
 - remove screws for the attachment of motor bridge at extract motor side, lower motor bridge to correct belt tension according to illustration and fasten bridge.

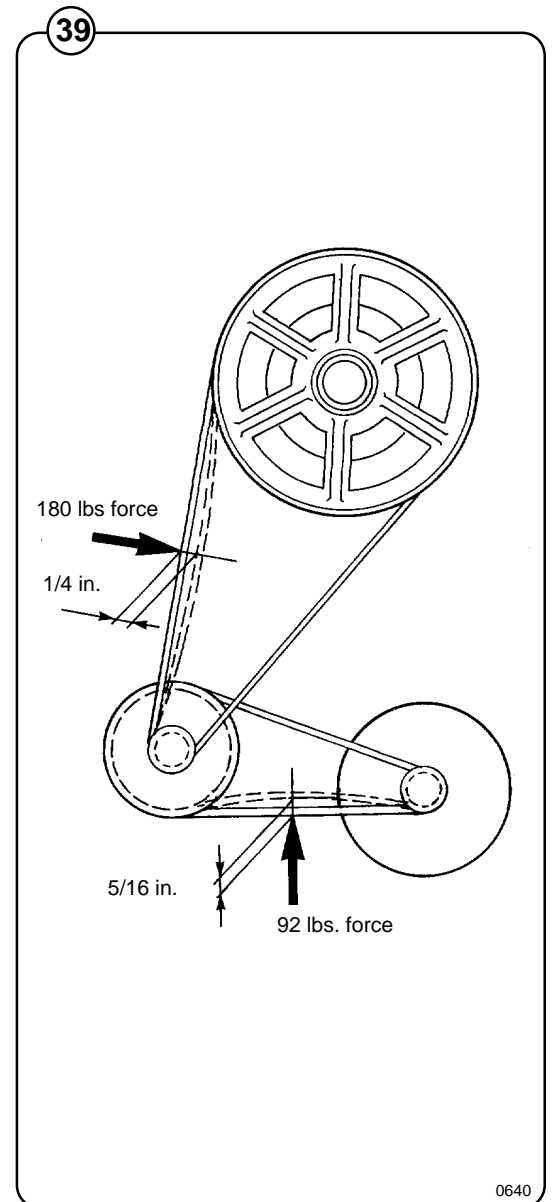

0640

Supply injection valve

Construction

Fig. 40 This valve has a single-inlet with three outlets, each with its own solenoid coil.

The body is made of heat-resistant polyamid plastic and the solenoids encased in water-tight plastic. The electrical connector terminals are spade lugs.

A filter screen on the inlet side prevents dirt from entering the valve. Flow restrictors can be placed at either the inlet or any of the outlets.

Operation

Fig. 41 When the solenoid is energized, the spring-loaded plunger is drawn up and the pilot valve in the center of the diaphragm opens. Because of the difference in diameter between the pilot valve opening and the ventilating hole in the diaphragm, the pressure above the diaphragm drops to a point where the admission pressure below the diaphragm can lift the diaphragm, thus opening the valve.

When the current to the solenoid is cut off, the plunger spring will press the plunger against the pilot opening of the diaphragm. The pressure above the diaphragm then rises to correspond to the water inlet pressure and the pressure of the spring will close the valve.

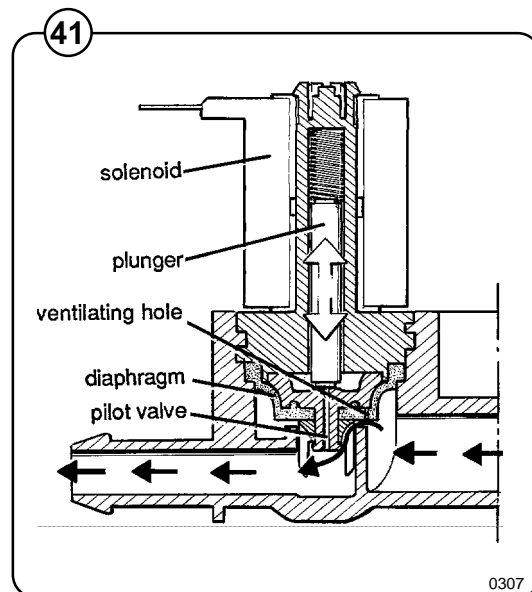
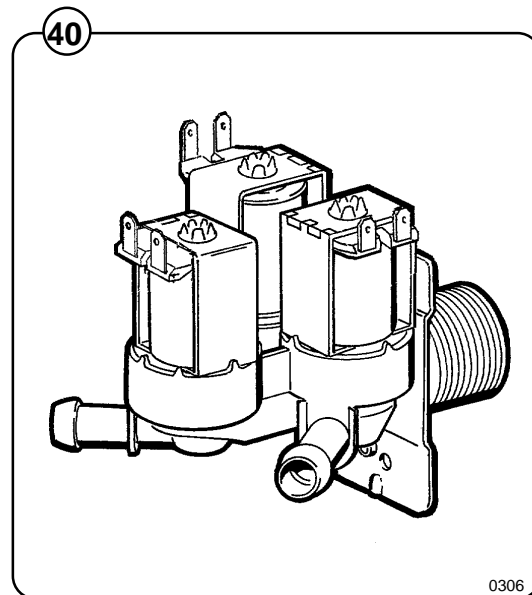

Repair instructions

Limescale can block the hole in the valve diaphragm and interfere with the function of the valve.

Fig. 42 It is therefore advisable to dismantle and clean the valve at certain regular intervals. The frequency depends on operating conditions and the level of contamination in the water.

If the valve does not open

- Check that power is supplied to the coil.
- Check the coil with an instrument to determine whether there is a break or a short circuit.
- Dismantle the valve (see below) and check the openings in the valve diaphragm.
- Check the inlet strainer and clean as required.
- Undo the coil and clean the surfaces of the magnetic core.

If the valve does not close

- Check that the coil is not live. The valve is normally closed when the magnet is not energised.
- Check the return spring.
- Check the diaphragm (pilot pressure opening).

Dismantling the valve.

Fig. 43 Pull the coil straight upwards. Use a screwdriver if necessary to carefully undo the coil.

Fig. 44 Use the tool supplied (attached to one of the hoses when the machine is delivered) to open the valve housing. Slide the tool over the protruding plastic sleeve to that the pegs on the tool engage the corresponding sockets in the valve housing.

Use a spanner or a pair of pliers and unscrew the upper part of the valve housing.

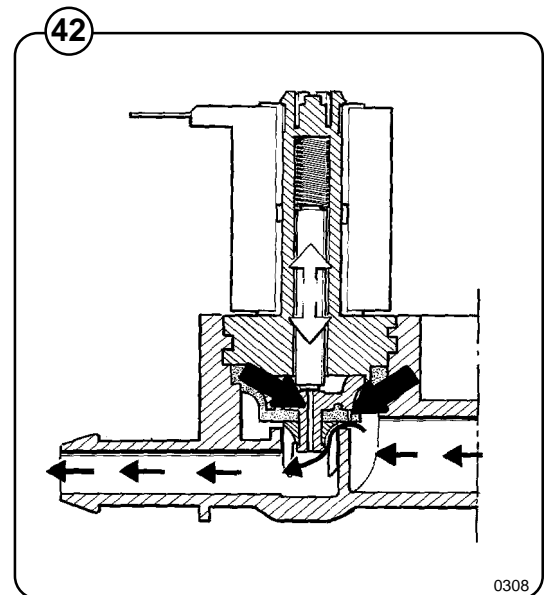

0308

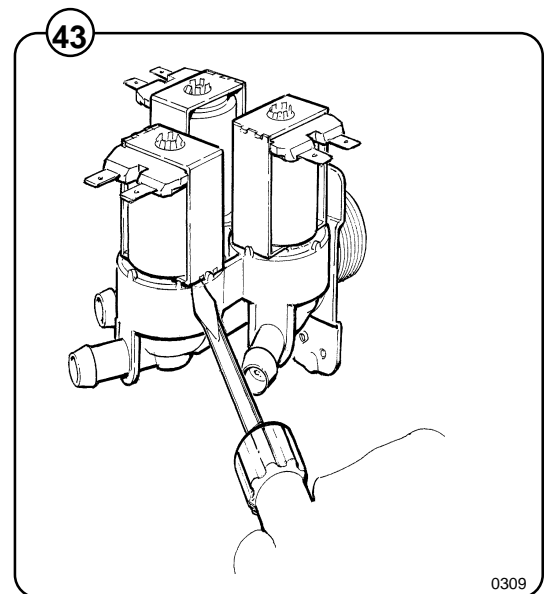

0309

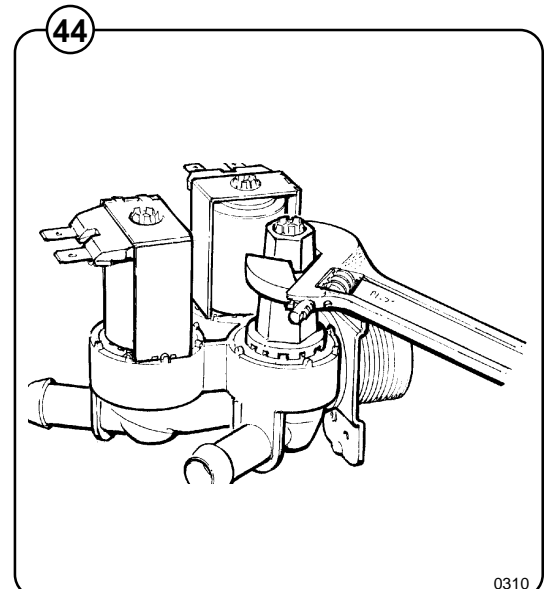

0310

Inlet valve EX 22

Fig. 45 The water inlets have brass bodies with a larger cross section of the outlet in order to achieve a shorter filling time for the machine.

Construction

The valve housing is made of pressed brass. The spring-loaded plunger is made of stainless steel and located at its lower end is a rubber gasket for the pilot valve.

Operation

The valve is automatically operated by means of a rubber diaphragm and a pilot valve in exactly the same way as the supply injector valve.

NOTE: To strip, clean, re-assemble and troubleshoot the inlet valve, follow the instructions outlined for the supply injector valve.

Clean out

At water temperatures of more than 60°C/140°F, the lime deposits are heavily increased. This can cause function problems due to blocking up the equalizing orifice of the valve.

Fig. 45 The fault can be eliminated by cleaning the equalizing orifice (marked A).

Fig. 46 If there are much deposits the orifice can be changed from 0.5 mm to 0.8 mm. The screwhead of the orifice is marked with 1 ring for the size of 0.5 mm and 2 rings for the size of 0.8 mm.

Clean the orifice as follows:

1. Shut off the main supply.
2. Unscrew the orifice

Fig. 47

3. Clean the hole in the orifice carefully with a pin or similar not thicker than 0.5 resp. 0.8 mm.
4. Mount the orifice, be careful with sealing and tighten.
5. Open the main supply.

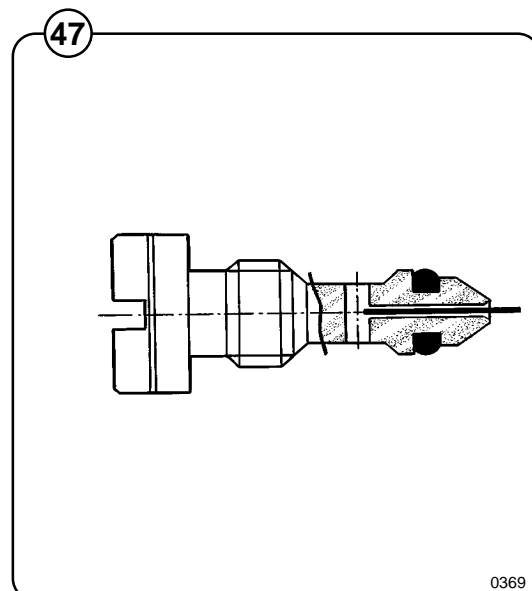
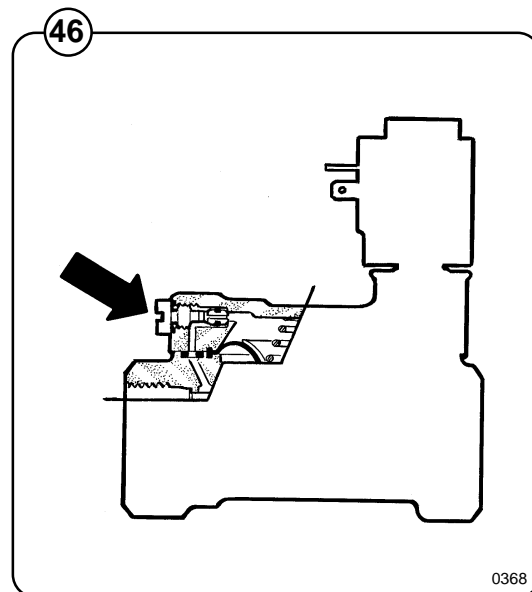
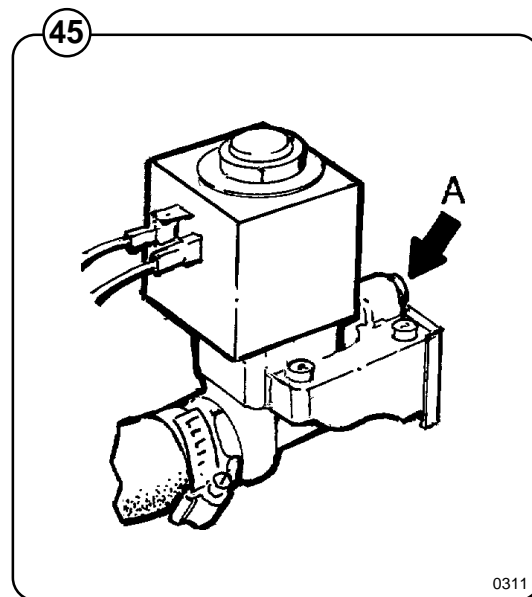

Soap supply box

Fig. 48 The three-compartment soap supply box is located at the top of the machine. Viewed from the front, the compartments are marked with figures 1, 2 and 3.

Compartment 1 and 2 are used for adding detergent directly to the wash. Compartment 3 is used for adding fabric softener. All three compartments can be programmed individually.

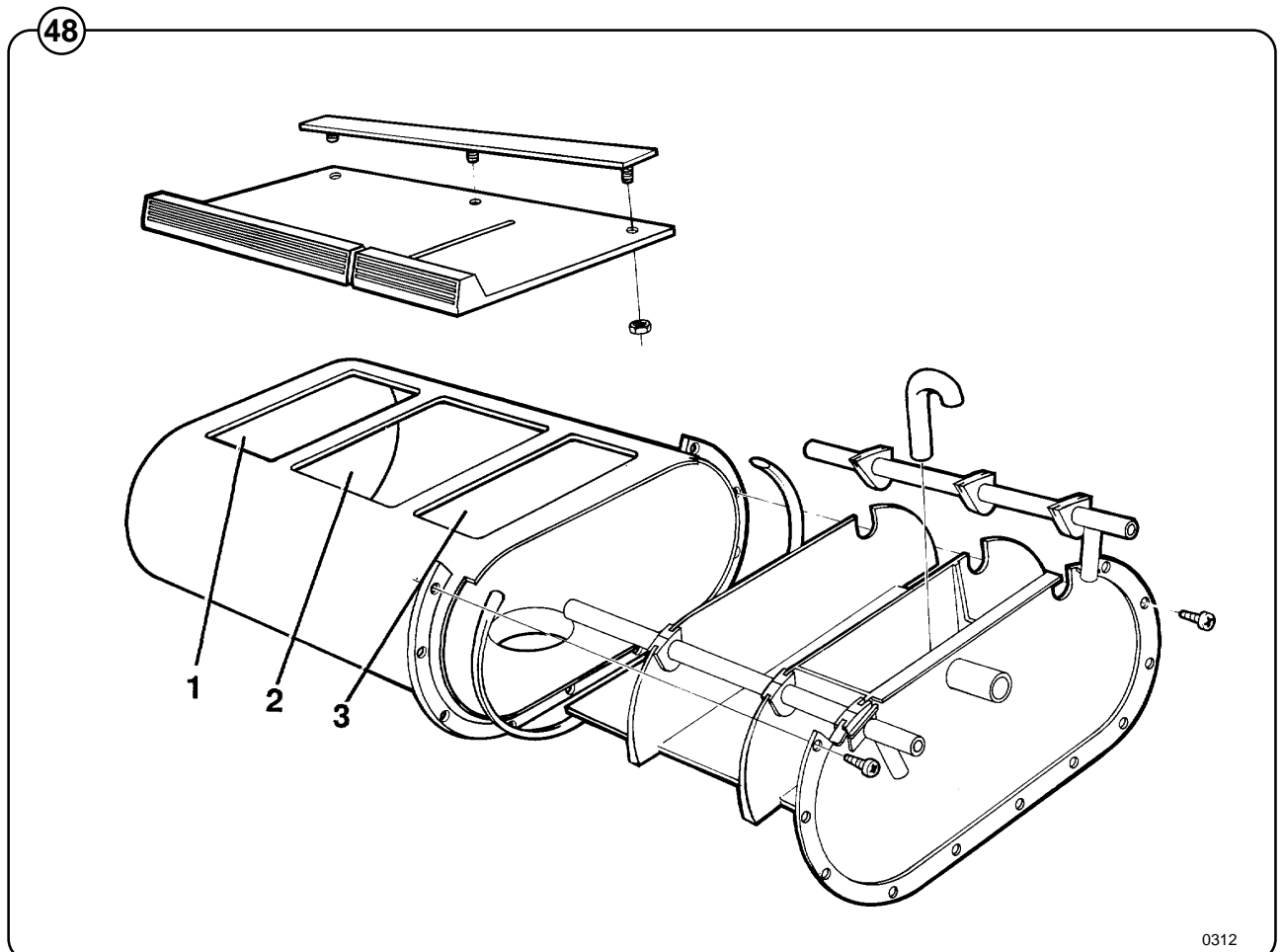

Drain valve

Description

Fig. 49 The drain valve consists of a bracket (1), on which are mounted the motor and gear (2) and diaphragm (3). The rubber diaphragm is resistant to a water temperature up to 100°C (212°F). The installation of a lint trap is not necessary. The machine is equipped with an overflow, which bypasses the drain valve. The drain can be cleaned by removing the drain connection (4) outside of the machine or by removing the rubber diaphragm (3). The motor and gear assembly is covered by a plate and provided with quick-disconnect electrical connections. The stator coil is constructed for continuous operation.

Operation

The drain valve is normally open, i.e. the motor does not close the valve until it receives current. As soon as the current is cut, the shaft turns and opens the diaphragm of the valve. This also permits the machine to drain, in the event of power failure. The overflow hose (5) leads excess water or suds directly to the waste line, in the event of failure in the inlet valves or level control.

Trouble-shooting

If the valve does not open or close properly:

1. Check that the shaft is moving freely.
2. Check that the diaphragm is not obstructed.
3. Check the coil for continuity.

Clean out

Periodic cleaning of the valve is recommended, depending upon how often the machines are used, as well as the type of wash handled most frequently.

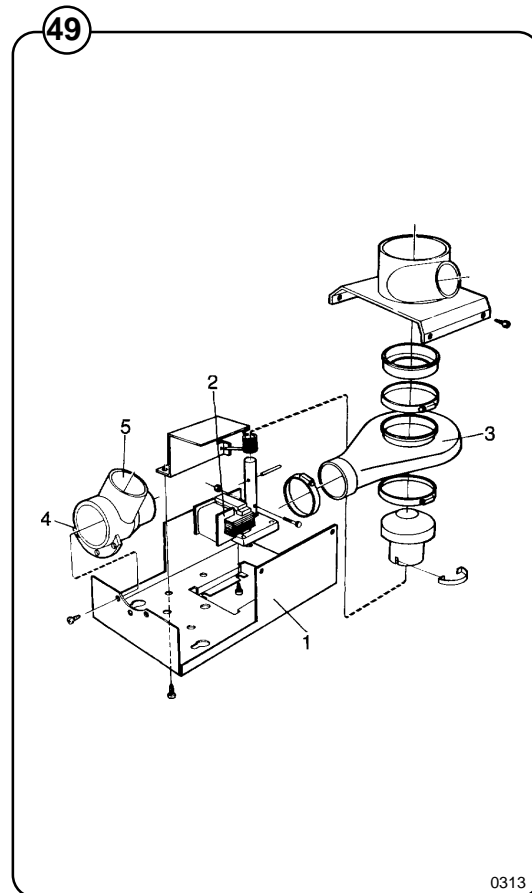

Card programming

General

Fig. 50 Programmable cards are used to regulate the different phases in a washing process. These are provided with a pattern of 16 ribs with pegs marked with the letters A-Q.

The cards are available in two sizes: 80 or 120 steps numbered from 0 upwards.

The program controls sense a step of 16 pegs across at one time. The card is fed forward by the program controls motor so that a new step is sensed. When the machine is filling with water or is heating the water, the program controls motor stops until the required level or temperature is reached.

If necessary, the program controls can be simply modified so that each step corresponds to one minute instead for 30 seconds.

Programming

Fig. 51 The principle applied to programming is to use a special pair of pliers to punch the pegs in the different stages. A peg that has been removed means that the corresponding function is activated when the program controls have fed that particular stage forward.

First mark the pegs you want to remove with a felt tip pen. Then make an additional check before you begin to punch the pegs.

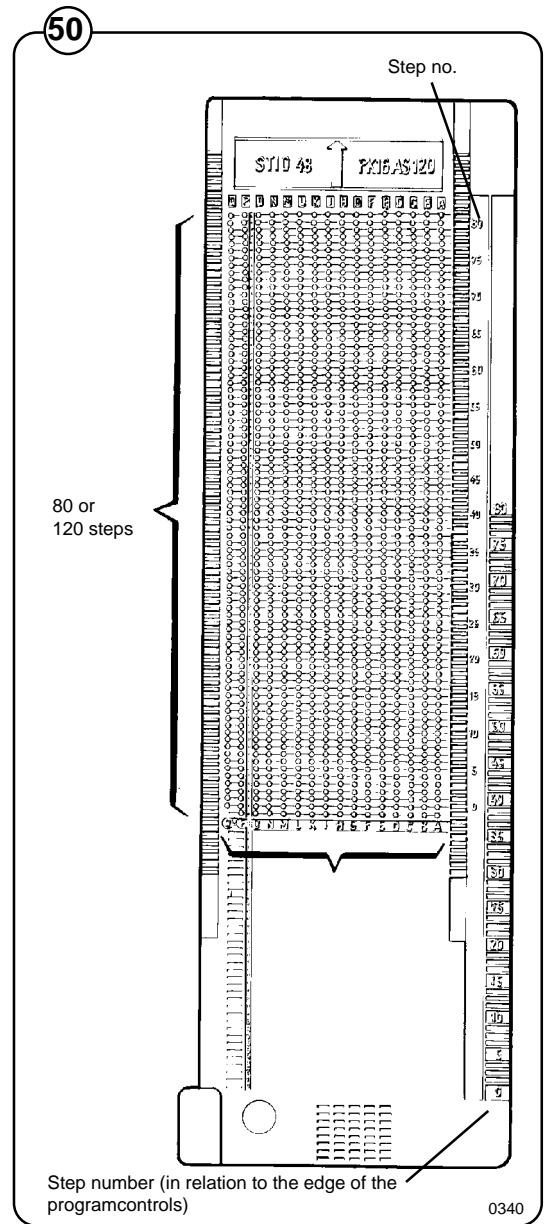

0340

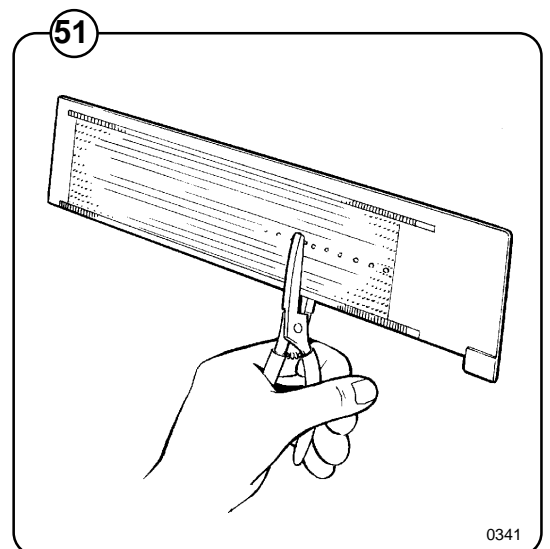

0341

Card programming

Fig. 52 The 16 ribs (A-Q) correspond to the following functions in the washing machine:

- A- Detergent compartment 1
- B- Heating, thermostat control B (red light)
- C- Detergent compartment 2
- D- Heating, thermostat control D (blue light)
- E- Liquid supply
- F- Heating, thermostat control F (yellow light)
- G- For liquid supply
- H- Low speed extraction
- I- Softener compartment 3
- K- Drain
- L- High speed extraction (with rib H also cut)
- M- Stop with signal
- N- High water level
- O- Filling with cold water
- P- Cool down (see explanation below)
- Q- Filling with hot water

Function M

Fig. 53 Stop with signal can be used as the last function in a program or in the event of a temporary stop in a washing process. A buzzer sounds when the machine stops and the yellow light in the **RESTART** button comes on. After a temporary stop the machine can be started again by pressing **RESTART**.

Function P

Cool down means that cold water is added gradually until the temperature of the wash water drops. This avoids the risk of creasing when changing from hot wash water to cold rinse water.

The cool down is appr. 3-4°C/min.

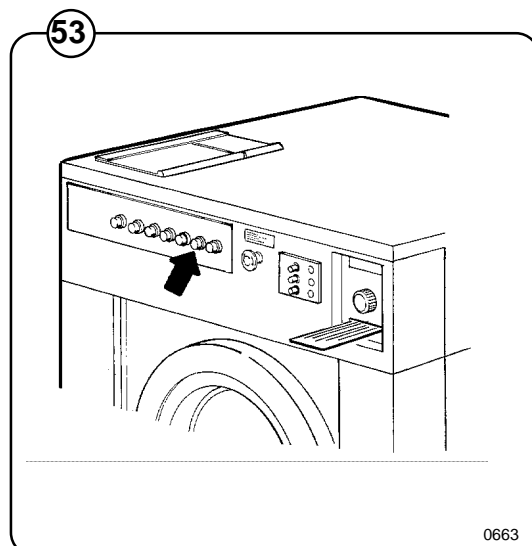
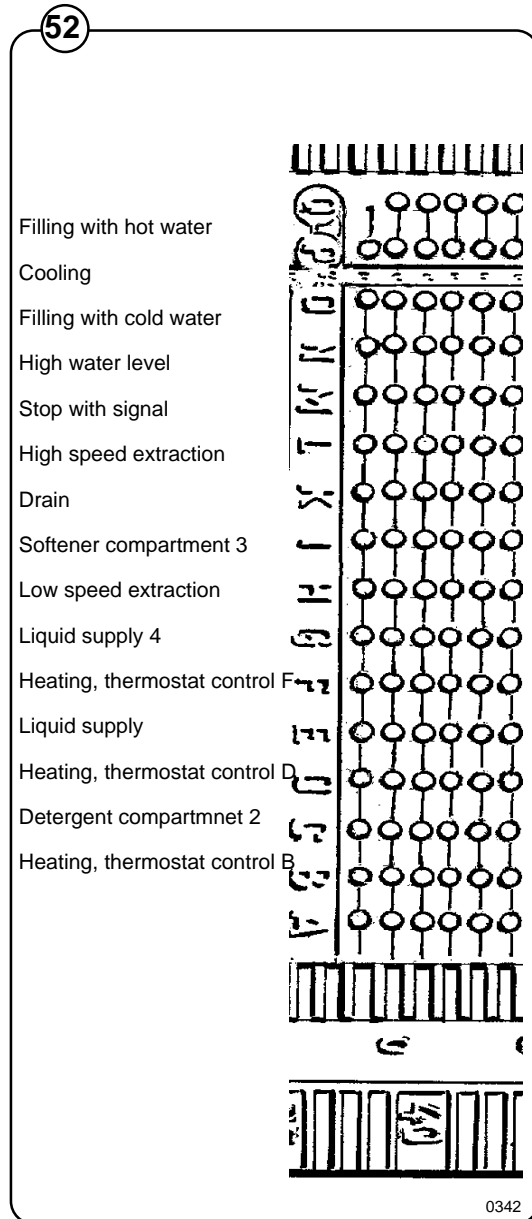

Instructions for programming

Fig. 54 • The program begins with step 0. Program the step before 0 in the same way as 0 to ensure a correct program start even though the card may be pushed too far into the controls.

• Program times

Fig. 55 - Each step in the program corresponds to 30 seconds.
 - The time for heating and filling with water shall not be included in the program time. This also applies when water is added for cool down (rib P). The program control motor is stationary during these phases.

• Extraction

- After the extraction has been in progress for about 70 seconds, the machine automatically changes to low speed extraction and then after 60 seconds go up to high speed extraction unless the **LOW SPEED EXTRACTION** switch is pressed in.

Fig. 56 - The drum should be filled with water to high level before draining and extraction starts. This is to ensure that the wash is effectively distributed around the drum.
 - Drain (rib D) must be programmed to last at least one minute (two program steps) before the extraction starts.
 - Drain shall be programmed during the entire extraction time and for at least 2,5 min afterward.

• Drain

- The machine always operates at distribution speed when drain is in operation (rib K).

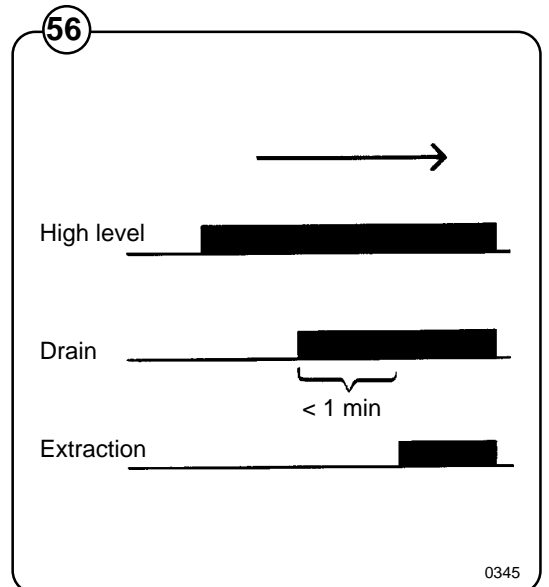
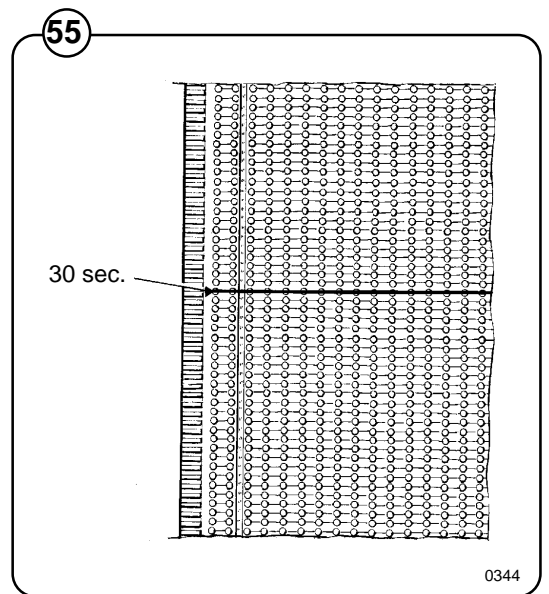
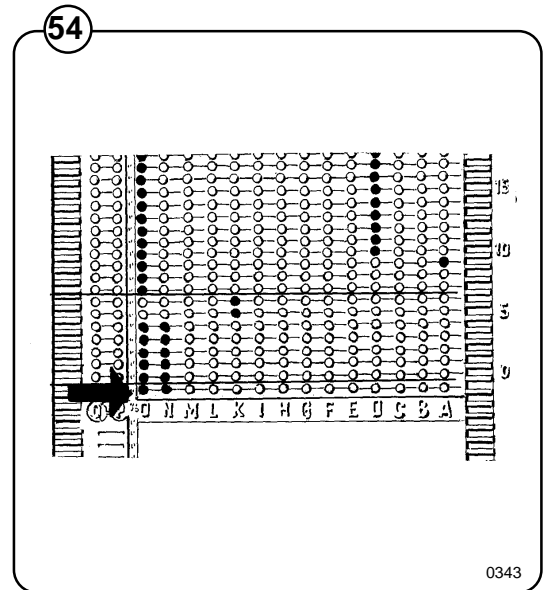

0343

0344

0345

Card programming

Programming example

Fig. 57 The following is a description of how the card for normal soiled goods would be programmed.

The time required for filling with water and heating must be added, where applicable, to the times stated.

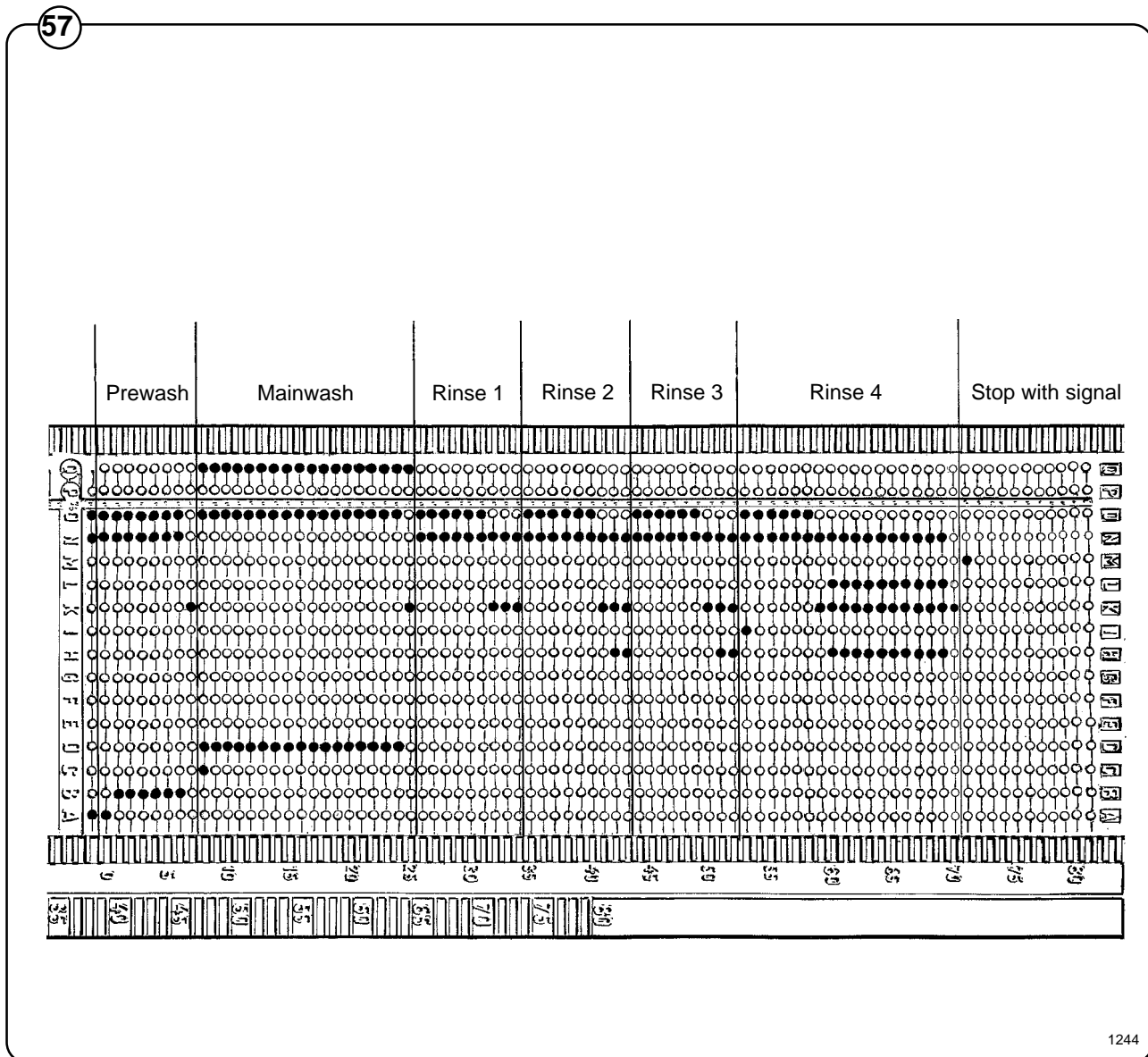

Pre-wash

Time: 4 minutes (steps 0-7)

The prewash comprises two phases:

1 Filling and prewash (steps 0-6)

Cold water is added (rib O) until high water level is reached (rib N) and is activated during the whole prewash cycle. This adjusts the level automatically while the program is in progress.

2 Draining (step 7)

The drain valve opens (rib K).

Main wash

Time 9 minutes (steps 8-25).

The main wash comprises three phases:

1 Filling with water and detergent (step 8).

Hot and cold water are added (ribs O and Q). The detergent is flushed down (rib C).

2 Washing (steps 9-24)

Heating to the temperature set by the thermostat marked D (rib D).

Filling with hot and cold water (ribs Q and O) and heating (rib D) are activated during the entire wash sequence. This controls the level and temperature automatically while the wash cycle is in progress.

3 Draining (step 25)

The drain valve opens (rib K).

Rinse cycle 1-3

These three rinse cycles are identical.

Time: 4 minutes and 30 seconds (steps 26-34, 35-43, 44-52).

Each rinse cycle comprises three phases:

- 1 Filling with water and rinsing (steps 26-31, 35-40, 44-49).

Filling with cold water (rib O) to high water level (rib N).

- 2 Draining (steps 32-34, 41-43, 50-52)

The drain valve opens (rib K).

- 3 Spin (steps 33-34, 42-43, 51-52).

Spin (rib H and rib L).

Note that the drain valve (rib K) and high level (rib N) are activated during the extraction.

Rinse cycle 4

Time: 9 minutes (steps 53-70).

This rinse cycle comprises four phases:

- 1 Filling with water and fabric conditioner (step 53).

Filling with cold water (rib O) to high water level (rib N). Fabric conditioner is flushed down (rib I).

- 2 Rinse (steps 54-58)

Filling with cold water (rib O) and high water level (rib N) are activated during the entire rinse sequence. This controls the level automatically while the rinse cycle is in progress.

- 3 Drain (steps 59-70)

The drain valve opens (rib K).

- 4 Extraction (steps 59-70).

Extraction (ribs H and L).

Note that the drain valve (rib K) and high level (rib N) are activated during the extraction.

Stop (step 71)

The machine stops and the buzzer sounds (rib M).

Fig. 58 The machine is supplied with a function test card which can be used for testing the different functions after installation.

All functions, which can be programmed on the card, are tested.

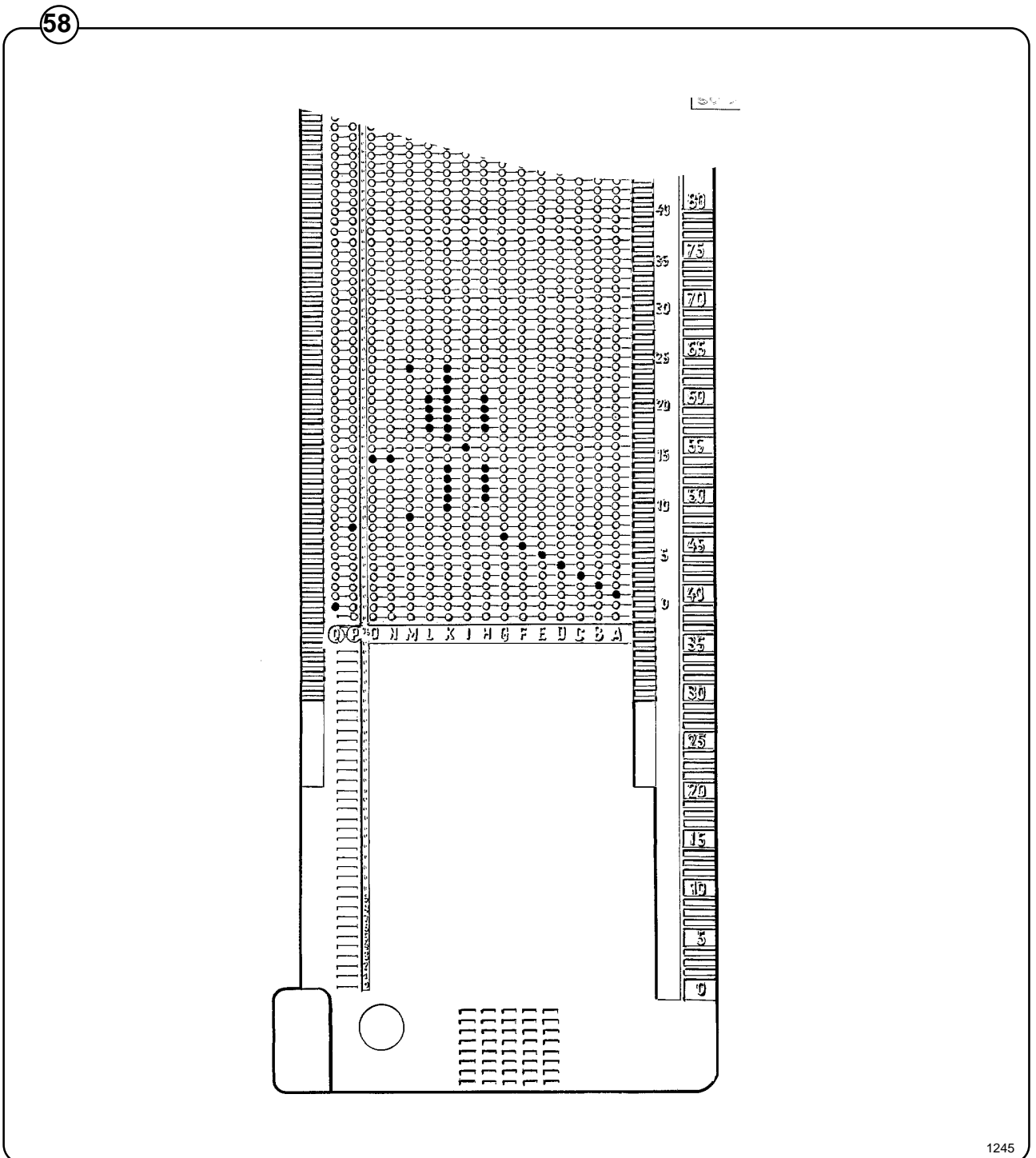

Procedure for use

Preparations

Sort the wash according to the washing instructions on labels.

Empty pockets and pull up zippers.

Open the machine door, insert the wash goods and close the door again.

Fig. 59 Measure the detergent and the fabric conditioner according to the instructions on the detergent packet and add to the soap box according to the program card you are using:

- pre-wash in compartment 1
- main wash in compartment 2
- fabric conditioner in compartment 3

The machine is also fitted with separate connections for liquid detergent.

Fig. 60 For auxiliary steam or electric heated machines, set the temperatures with the thermostat controls. Use the control marked **B** (red lamp) for manual washing.

Fig. 61 When washing delicate fabric, press **GENTLE ACTION**. This provides more gentle treatment of the wash goods.

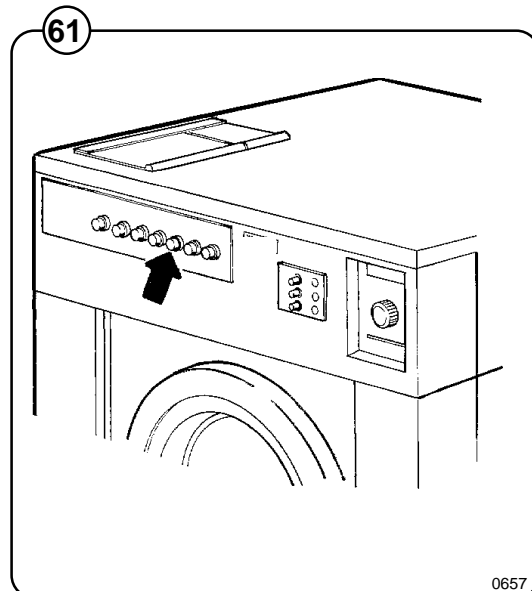
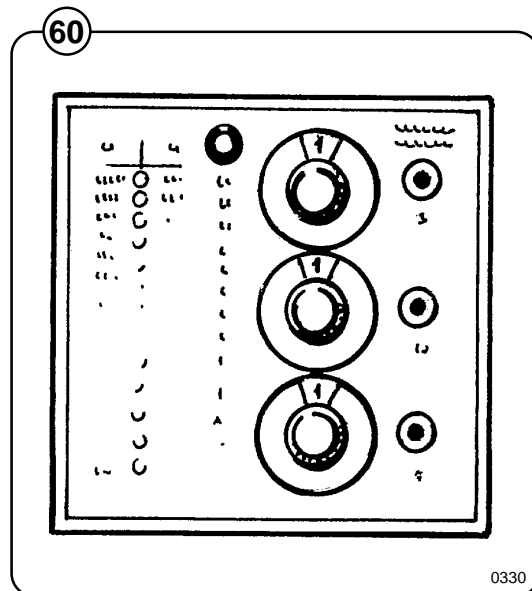
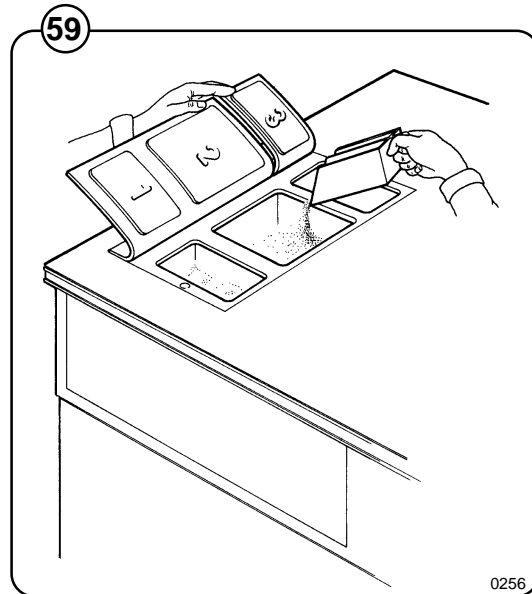

Washing

Fig. **62** Turn the dial on the card programmer control panel to the **0 (STOP)** position. Insert a programmed card, with the pegs upwards, into the opening below the control. Push the program card in as far as it will go.

Fig. **63** Press **1-0 (ON/OFF)**, push-button switch.

Fig. **64** Start the machine by turning the dial on the programmer control panel to the **I (START)** position.

Fig. **65** The water level can be raised while the program is in progress by using the push-buttons for water.

Additional detergent from compartment 1 can be flushed down by pressing the **FLUSHDOWN** push-button.

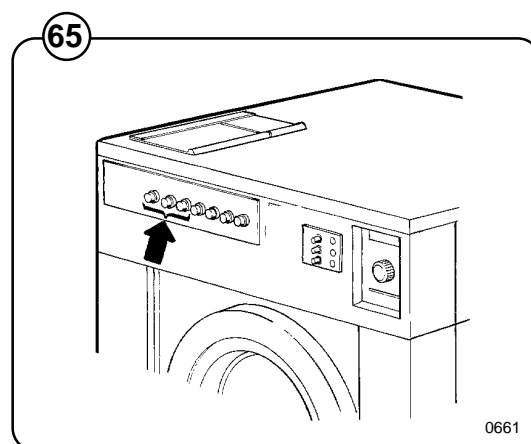
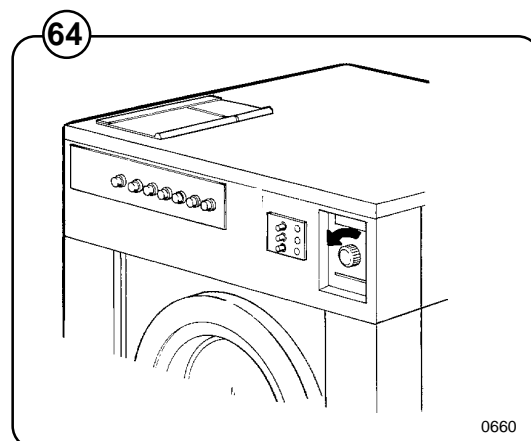
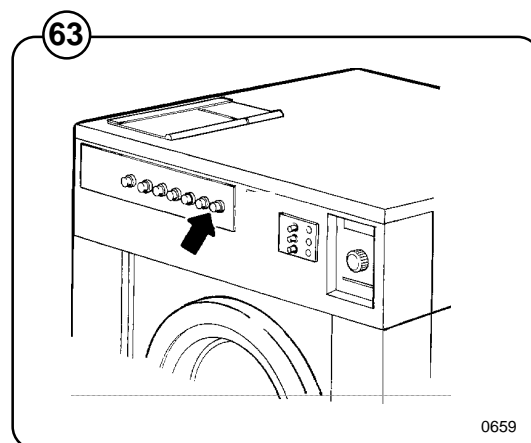
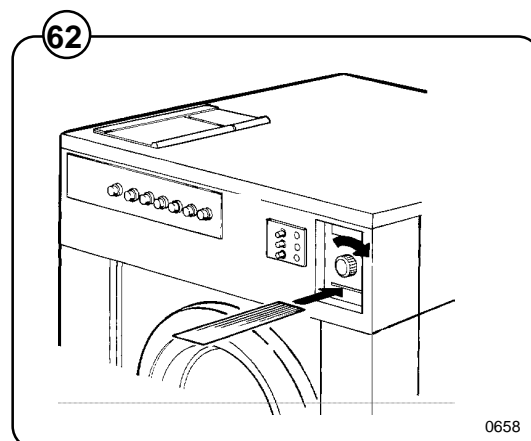

Programmed stop

If "Stop with signal" has been programmed, the machine will stop, a buzzer will sound and a yellow light on the **RESTART** button will come on.

Fig. 66 The machine is started again by pressing the **RESTART**, push-button.

After use

Fig. 67 Turn the dial on the programmer control panel to **O (STOP)** and switch off the machine with the **I-O (ON/OFF)** switch.

CAUTION

The door is locked while the wash program is in operation and cannot be opened until 2-3 min. after completion of the program.

Open the door and remove the wash goods.

Clean the detergent compartments and the door seal as necessary. Wipe down the machine with a damp cloth.

Fig. 68 Leave the door open if the machine is not going to be used.

Leave the machine in the condition in which you would wish to find it.

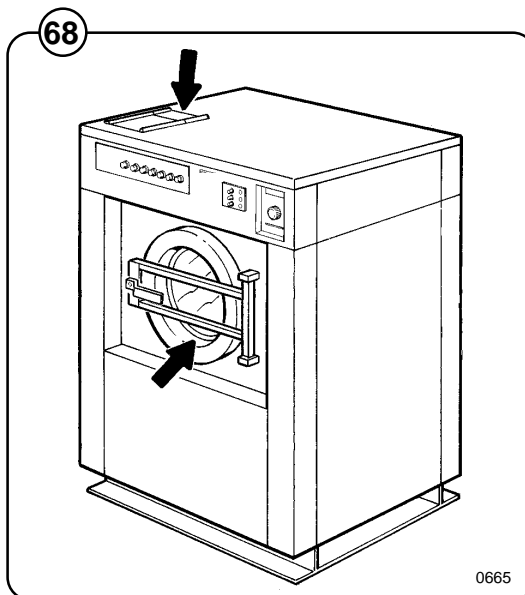
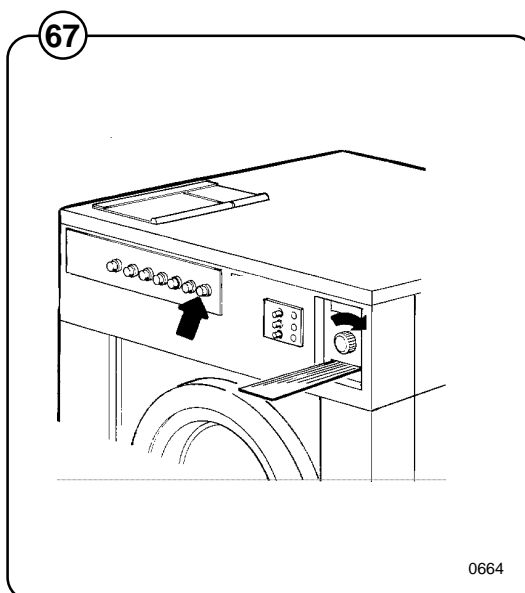
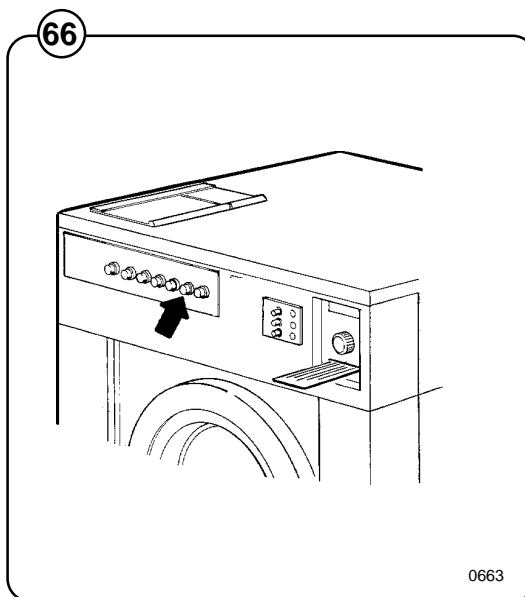

Manual washing

Fig. **Drum rotation**

69 To produce drum rotation during manual washing, an unprogrammed card must be inserted in the program controls and the programmer knob turned to I (START).

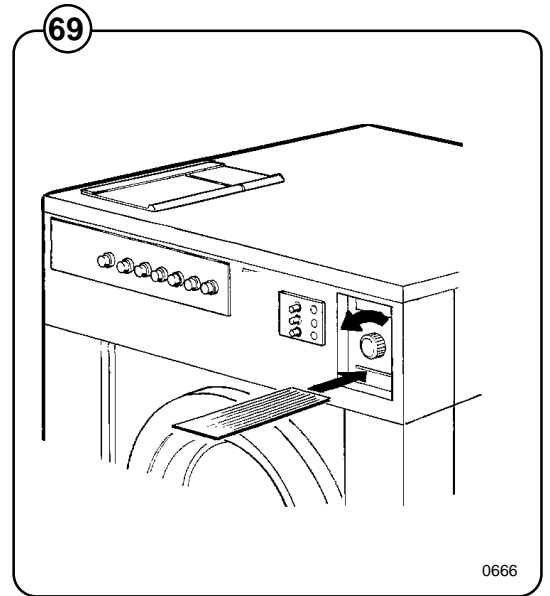

Water filling with detergent and drain

Fig. **Fill with water by pressing COLD WATER and/ or HOT WATER.**

70 Use **FLUSHING DOWN DETERGENT** to flush down the detergent from compartment 1 (prewash).

Water is drained from the machine with **DRAIN**.

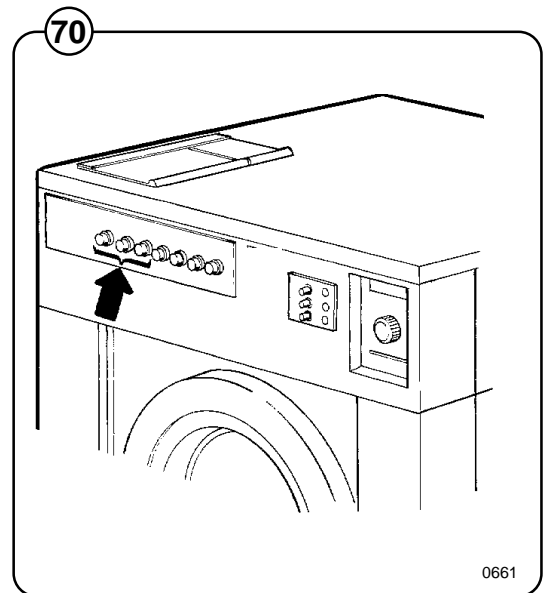

Heating and extraction

A card must be programmed to provide these functions. Refer to the section on card programming.

Caution

For extraction, the "drain" phase must be programmed for at least 30 seconds (one program step) before extraction takes place. In addition, "drain" must be programmed during the entire extracting time (and for 30 seconds after wards for final extraction).

Maintenance

The carefully considered machine design means that preventive maintenance to reduce faults has been reduced to a minimum. The following measures should however be carried out at regular intervals and to the extent determined by the amount of time the machine is used.

Daily

- Fig. 71
- Clean the door seal and remove detergent residue and check that there are no leaks.
 - Clean the detergent compartments and wipe down the machine with a damp cloth.
- Fig. 72
- Check that the drain valve does not leak.
 - Start the machine with the program card inserted and check that the door remains locked while the machine is operating. Let the machine run for 2 minutes. Stop the machine by turning the control on the control panel to 0. Check that the door cannot be opened until 2-3 min. after the program is completed.

Every three months

- Check that valves, hoses and connections do not leak.
 - Remove any textile lint from the drain opening.
- Fig. 73
- Remove the cover plates of the machine and check that the V-belt of the wash motor is undamaged and correctly tensioned.
 - Wipe and clean the inside of the machine, making sure that the control components are protected from moisture and dirt during the cleaning operation.
 - Check level of oil in electro-lube oil dispenser.

Troubleshooting

If the machine does not start, check that:

- the machine's circuit breaker is on,
- the **0-1 (ON/OFF)** switch is pressed on,
- the door is properly closed,
- the program card is inserted and the programmer control dial is turned to **I (START)**.
- both taps on the wall are turned on.

Contact your service engineer if any fault persists.

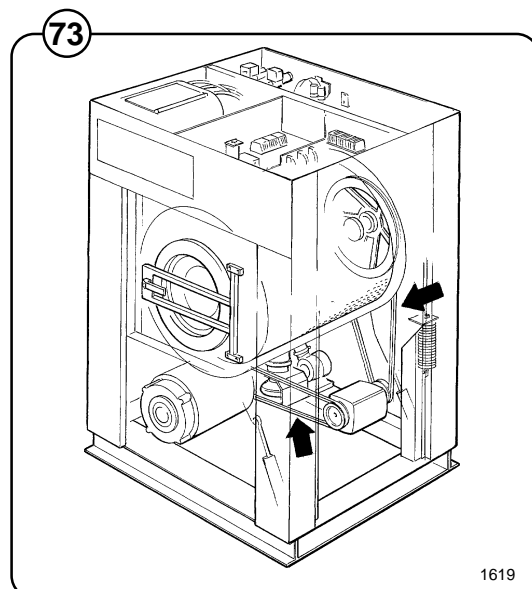
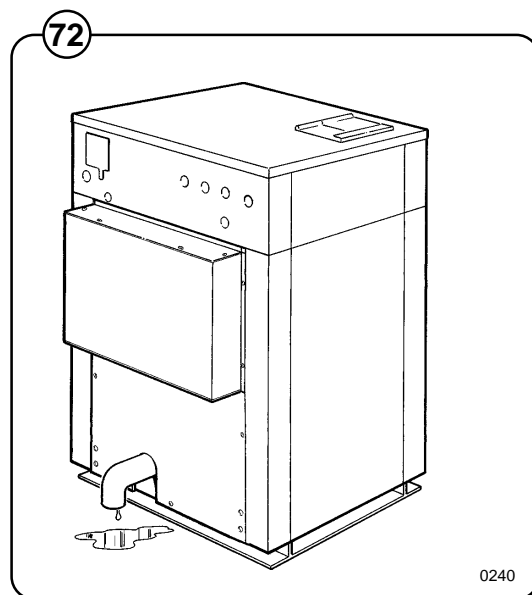
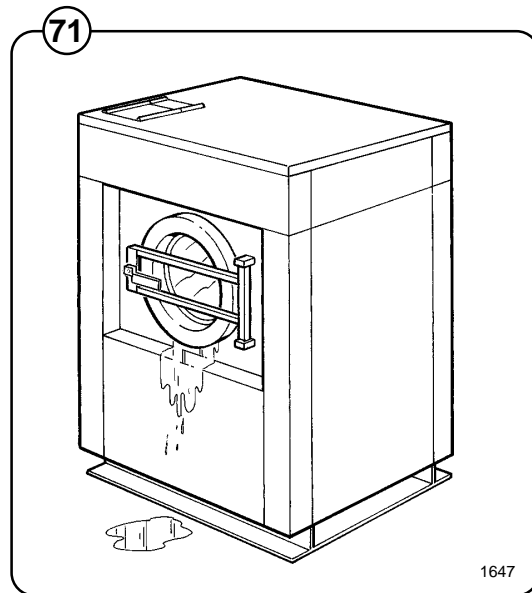

Trouble shooting

The purpose of the trouble shooting guide is to facilitate the location and correction of the most common machine problems.

Before the top panel is removed, power to the machine is to be switched off at the main source or at the separate circuit breaker.

At each trouble shooting attempt, the plug in connectors of the control panel should be moved in and out in order to eliminate improper contact due to faulty connection.

Please note that this guide does not include all possibilities, but only those most likely to cause the symptoms listed.

In trouble-shooting electrical problems, always make certain to have the proper electrical schematic or wiring diagram at hand. Test for power using a V-O-M or similar meter on the AC voltage scale. Test for continuity with all electrical power off.

If machine does not start

- A Check the circuit breaker in the power feed line to the machine.
- B Check the door safety switches.
- C Check the glass cartridge fuse.
- D Check the normally closed auxiliary contact on the extract relay.
- E Check reversing switch.
- F Check the V-belt and motor.
- G Check programmer switch M.
- H Check the start switch on the side of the programmer.

If water does not drain

- A Check the drain valve and motor and gearing for proper operation.
- B Disconnect drain hose connected to drain line. If full flow of water comes out, the problem is in the main waste line. If water flow is slow, the problem is the accumulation of foreign materials between the drain valve and drum outlet of machine.
- C Clean valve body for any foreign objects.
- D Check program switch K.
- E Check the drain relay.

If machine does not extract

- A Check extract relay and relay coil for proper operation.
- B Check programmer switches H and/or L
- C Check the extract safety level control.
- D Check the reversing switch.
- E Check the door lock.
- F Check all the drain items of "If water does not drain".

If motor does not operate at wash speed

- A Check wash relay.
- B Check motor and V-belt.
- C Check reversing mechanism.
- D Review procedures outlined under Section 1 above.

If machine runs slowly on wash speed or there is a slapping or thumping noise.

- A Replace V-belts

If a metallic noise can be heard at rear of machine

- A Tighten pulley on motor shaft

If the door is leaking

- A Check door gasket. If gasket is in good condition, check the tension, between door gasket and door frame and adjust.

If there is leaking around the glass

- A Re-cement glass in door gasket.
- B Replace door gasket if worn.

If water does not enter machine.

- A Check the valve coils on inlet valves.
- B Check wires leading to electric coils.
- C Be sure manual shut-off valves are in open position.
- D Check contacts on programmer.
- E Check water level switch and plastic tubing.
- F Check programmer switches K, N, O and Q.

If water continues to fill without stopping and programmer DOES NOT advance

- A Check water level control.
- B Check that rubber tube is not plugged and that plastic tube has no air leaks.

If water continues to flow without stopping and programmer DOES advance

- A Check inlet valves for dirt underneath the valve diaphragm. To localize, shut off power. If water continues to flow, inlet valves have foreign material in them and should be thoroughly cleaned.
- B Check level control.

If water continues to flow without filling machine

- A Check seating of drain valve.

If programmer does not advance

- A Check synchronous motor on programmer.
- B Check water level control and the rubber tube leading to same.
- C Check for leak in drain valve which would prevent machine from reaching its pre-set water level in order to energize the programmer.

If machine does not reverse

- A Check reversing mechanism.
- B Check auxiliary contact on extract relay.

If drum vibrates excessively

- A Check wash load. Do not underload the machine.
- B Check the adjustment of out of balance switch.
- C Check shock absorbers.
- D Check springs.

If safety fuse blows at the beginning of the cycle

- A Replace fuse.
- B Disconnect wires leading to the delay circuit of the door lock. Replace fuse and start. If the machine now works, replace delay circuit.