FCS1362:2010

UK CODE OF PRACTICE for the installation of mobile radio and related ancillary equipment in land based vehicles

(SUPERSEDES MPT1362)



FCS1362:2010
UK CODE OF PRACTICE
for the installation of mobile radio
and related ancillary equipment
in land based vehicles
(Supersedes MPT1362)

First published as MPT1362 1987 (with Crown Copyright)

First revision 1990

Reprinted 1991

Revised and Reprinted March 1997

Second revision 2001

Reprinted 2002

Third Revision 2005

Minor amendments 2007

FCS1362 Supersedes MPT1362 in subsequent editions

Fourth Revision 2008

Fifth Revision 2010, known as FCS1362:2010

Published by Federation of Communication Services

© Copyright 2010 – FCS

The Federation of Communication Services owns the copyright to this document, which is published on the FCS web site <http://www.fcs.org.uk>

Reproduction in whole, or in part, of any of this document is permitted but no changes may be made to the text or contents. Any reference to the document in part or entirety should have an acknowledgment of its source. Any other requests regarding this document and its contents must be made to the following address:

Federation of Communication Services
Burnhill Business Centre
Burrell Row
Beckenham, Kent
BR3 1AT

Tel: 020 8249 6363

Fax: 0844 870 5927

e-mail: fcs@fcs.org.uk

Web: <http://www.fcs.org.uk/>

Foreword

This code of practice document applies when installing all forms of mobile radio and telephony equipment, along with any ancillary or auxiliary products, in land based vehicles of various types.

The guidance within this document does not differentiate between the types of apparatus and end services provided, whether voice systems, data services or other applications, as each piece of equipment being fitted to a vehicle is to be treated as an entity requiring power, wiring, connectors, fixings and subsequent testing to prove the robustness and quality of the installation.

The ultimate aim of this code of practice is to help achieve:

A SATISFIED CUSTOMER WITH A SAFE AND EFFICIENT INSTALLATION

Attention is drawn to the beginning of section 2 which states the obligations and responsibility that an installer has. Reference to 'customer' in this document includes the end user, their agent or their appointed agent.

This code of practice is not a mandatory document and is published as guidance and best practice. Where specific equipment and/or vehicle manufacturers' procedures for installation exist, they take precedence over procedures stated in this document.

No liability whatsoever, in respect of damage to vehicles, equipment or personnel, can be accepted by either the publishers or any persons involved in the writing of this document.

The groups and organisations that have contributed to the code of practice are listed in section 7.

FCS1362:2010 is intended to be used in conjunction with a set of references that will be maintained on the FCS website:

<http://www.fcs.org.uk/MemberGroups/Installers/FCS1362Links.aspx>



Contents

Foreword	3
Scope	8
1. Definitions and Abbreviations	9
1.1. Definitions.....	9
1.2. Abbreviations.....	11
2. Guidelines for safe & legal installation of equipment	13
2.1. Insurance.....	13
2.2. Legal compliance requirements.....	13
2.2.1. Compliance markings.....	13
2.2.2. Compliance requirements, new equipment	13
2.2.2.1. New equipment for vehicles or motorcycles	13
2.2.2.2. New equipment for buses, trucks & agricultural vehicles	14
2.2.3. Compliance requirements, legacy equipment	14
2.2.4. Specialised vehicle compliance requirements.....	14
2.2.5. Compliance for vehicles carrying dangerous goods.....	15
2.2.6. Compliance for ambulances.....	15
2.2.7. Other specialised vehicles	15
2.2.8. Compliance for vehicles with less than four wheels	15
2.3. Legal requirements for installation work.....	16
2.3.1. Use of equipment & vehicle supplier's instructions.....	16
2.3.1.1. Transmitter power output & definition of higher power	16
2.3.1.2. Equipment & vehicle supplier's warranty	17
2.3.2. Disposal of electronic equipment and batteries.....	17
2.3.2.1. Disposal by the manufacturer	17
2.3.2.2. Disposal through membership of an approved compliance scheme.....	17
2.3.2.3. Disposal by a local authority	18
2.3.2.4. Secure disposal	18
2.4. General safety during installation	18
2.4.1. Safety of personnel	18
2.4.2. Working environment	18
2.4.2.1. Safety on specific installation sites.....	18
2.4.3. Clothing	18
2.5. Locating equipment.....	19
2.5.1. Locating equipment & cables in vehicles fitted with airbags & SRS.....	19
2.6. Fixings, connectors and tools.....	19
2.6.1. Fixings.....	19
2.6.1.1. Fixing types	20
2.6.1.2. Methods of fixing equipment	20
2.6.1.3. Cable retention & tidying.....	20
2.6.1.4. Connectors & joining cable	21
2.6.1.4.1. Joining two cables	21
2.6.1.4.2. Joining, or cutting into an existing loom or cable	22
2.7. Connecting to vehicle data bus	22
2.7.1. Single Vehicle Architecture	22
2.8. Antenna mounting safety.....	23
2.8.1. Antenna physical hazards	23
2.8.2. Antenna location safety.....	23
2.8.2.1. Electromagnetic and radio frequency interference.....	23
2.8.2.2. Radiating antenna location safety	23
2.8.2.3. Antenna height and length safety.....	23
2.8.2.4. Magnetic base antenna safety	24
2.8.2.5. On-glass antenna safety	24
2.8.2.6. Antenna safety on motorcycles	24

2.9.	Precautions when working on vehicles	24
2.9.1.	Electric powered and hybrid vehicles.....	24
2.9.2.	Vehicle battery disconnection.....	24
2.9.2.1.	Battery disconnection and existing electrical and electronic equipment.....	25
2.9.2.2.	Battery isolation and seat mounted airbag.....	25
2.9.3.	Master isolation switch	25
2.9.4.	Power to installed equipment	25
2.10.	Recommended tools & test equipment	25
2.11.	Drilling holes	26
2.11.1.	Preparation for drilling holes.....	26
2.11.2.	Hole drilling.....	26
2.11.3.	Hole sealing & protection	26
3.	Planning, preparation and pre-installation guidance	27
3.1.	Planning installation requirements and customer consultation	27
3.2.	Customer consultation	27
3.2.1.	Customer instructions for installations	27
3.2.2.	Work cessation when customer wishes conflict with safety	27
3.3.	Pre-check of mobile equipment	28
3.4.	Installation documentation.....	28
3.4.1.	Job sheet.....	28
3.4.2.	Installation report	28
3.4.3.	Pre-installation sign-off.....	28
3.5.	Protection of bodywork and interior	28
3.6.	Pre-Installation Procedure.....	28
3.6.1.	Vehicle inspection	29
3.6.1.1.	Fuel leaks.....	29
3.6.2.	General aftermarket equipment.....	29
3.6.2.1.	Child seats & booster seats	29
3.6.2.2.	Valuables	29
4.	Installation procedures.....	30
4.1.	Installation of antenna and coaxial cable	30
4.1.1.	Antenna types.....	30
	Table 1 - General table of antenna type to typical network performance	30
4.1.1.1.	Internal antennas.....	31
4.1.1.2.	Antenna bases and whips.....	31
4.2.	Antenna installation.....	31
4.2.1.	Avoiding interference	31
4.2.2.	Approximate frequency to wavelength conversion	32
	Table 2 - Approximate frequency to wavelength conversion	32
4.2.3.	Locating antennas on vehicles	32
4.2.3.1.	Antennas and sunroofs.....	33
4.2.3.2.	Fuel filler caps	33
4.2.4.	Fitting antennas	33
4.2.4.1.	Panel mount antenna.....	33
4.2.4.1.1.	Panel mount antenna on vehicle with electrically isolated chassis	33
4.2.4.2.	Antennas on non-metallic panels	34
4.2.4.3.	On-glass antennas	34
4.2.4.4.	Specialist antennas.....	34
4.2.4.5.	Covert radiating antennas	34
4.2.4.6.	GPS antenna.....	35
4.2.4.7.	Temporary antennas.....	35
4.2.5.	Coaxial cable to antenna.....	35
	Table 3 - Coaxial Cable – Typical Loss per Metre for Different Types	36
4.2.5.1.	Routing of the antenna cable	37
4.2.5.2.	Fitting of coaxial connectors.....	37

4.3.	Installation of cables	37
4.3.1.	Routing of power and control cables.....	37
4.3.1.1.	Grommets	37
4.3.1.2.	Routing cables.....	38
4.4.	Components of the installation	38
Table 4 -	Components of the installation	38
4.4.1.	Slave handset/fist Microphone	39
4.4.2.	Hands free microphone	39
4.4.3.	Loudspeaker	39
4.4.4.	Microphone and loudspeaker positions.....	39
4.4.5.	Distribution boxes and transceivers	40
4.4.6.	Remote controls.....	40
4.4.7.	External alert facility	40
4.4.8.	Installation of auxiliary mobile equipment	40
4.4.8.1.	Auxiliary equipment power requirements.....	40
4.5.	Audio muting and audio routing facilities.....	41
4.5.1.	Guidelines for removal, connecting & refitting of ICE	41
4.5.1.1.	ICE audio integration, mute lead, ISO2CAR & SOT leads	41
4.5.1.2.	Wiring harness checks.....	41
4.5.1.3.	Warning tones & ICE	42
4.5.1.4.	Reconnecting ICE.....	42
4.6.	Equipment power source.....	42
4.6.1.	Equipment with high current rating	42
4.6.2.	Provision of a dedicated/permanent power supply cable.....	42
4.6.2.1.	Installing power supply cable	43
4.6.3.	Fusing.....	43
4.6.4.	Negative Feed Connection	43
4.6.5.	Sourcing ignition sense	43
4.6.5.1.	Provision of ignition sense from an ignition feed	43
4.6.5.2.	Provision of an ignition feed	44
4.6.6.	Vehicle supply greater than 12 volt.....	44
4.6.6.1.	Voltage regulator/converter.....	44
4.6.7.	Isolated power supply	44
4.6.7.1.	24V or higher isolated supply	44
4.7.	Basic checks of an installation.....	44
4.7.1.	Equipment power supply checks	44
4.7.2.	Isolated supply system checks	45
4.7.2.1.	Isolated converter or regulator checks.....	45
4.8.	Testing Antennas	45
4.8.1.	Antenna DC tests.....	45
4.8.2.	VSWR measurements and analysis for transmitting antennas	46
4.8.2.1.	Undertaking VSWR test.....	46
4.8.3.	Testing GPS antennas	47
4.9.	Power up testing	47
4.9.1.	Transmitter output power	47
4.9.2.	Equipment using ignition sense	47
4.10.	Reassemble vehicle	48
4.11.	Uninstalling equipment.....	48
4.11.1.	Aims of equipment de-install	48
4.11.2.	Equipment de-install procedure.....	48
5.	Test and final Inspection	50
5.1.	Vehicle and site check	50
5.2.	Installation Checks.....	50
5.3.	Final Tests.....	50
5.3.1.	Static tests of vehicle and equipment functions.....	50
5.3.2.	Checks to be undertaken during final testing of installation	50

5.3.3.	Checks on emergency service vehicles	51
5.3.4.	Vehicle's engine and ignition during testing	51
5.3.5.	Dealing with problems found in final testing	51
5.3.6.	Road testing	51
5.3.6.1.	Requirements for undertaking a road test safely	52
5.3.7.	Recording findings of a road test	52
6.	Demonstration and Customer Training	53
6.1.	General	53
6.2.	Safety instructions	53
6.3.	Handing over	53
7.	Acknowledgments	54
	Review Chairman	54
	Contributors	54
	Appendix A: Installation Process Flow Chart	55
	Appendix B: Further information and documentation	56
	Appendix C: Contact information	58
	Appendix D: Example installation report forms and check lists	60
	Sample form 1	60
	Sample form 2	61
	Appendix E: Antenna radiation patterns	63
	Antenna mounted on centre of roof	64
	Antenna mounted towards rear of vehicle roof, saloon type vehicle	65
	Antenna mounted towards rear of vehicle, estate/van type vehicle	66
	Antenna mounted on rear off side wing	67
	GPS receiving antenna	68
	TETRA ¼ wave whip antenna	69
	TETRA co-linear whip	70
	Appendix F: Multiple antenna installation	71
	Appendix G: Covert antenna location and radiation patterns	72
	Appendix H: Swept area of the windscreen	73
	Appendix I: Example Declaration of Conformity	74

Scope

This code of practice provides guidance for the installation in land based vehicles of:

- mobile telephones and other communication devices such as PDA and data terminals
- business radio such as PBR equipment
- in-vehicle mounting kits for transportable and handheld equipment
- mobile equipment
- telematics
- ancillary and auxiliary equipment associated with the above

It does not cover the installation of equipment in aeronautical or marine environments.

This code of practice:

- details recommended methods for safe and efficient installation of equipment in the vehicle
- covers aspects of safety relating to installation of additional physical equipment in vehicles
- recommends the installation methods to minimise the possibility of electromagnetic interference between the installed equipment and the vehicle's electrical and electronic systems
- gives recommendations for instructing vehicle users in the efficient use of radio communications equipment along with reference to the statutory requirements associated with the operation of such equipment in moving vehicles

Appendix A illustrates the installation process in a flow chart.

A large, light gray watermark consisting of the letters 'FCS' in a bold, sans-serif font. To the right of the letters is a graphic of several concentric, curved lines that resemble a radio signal or a stylized wave.

1. Definitions and Abbreviations

1.1. Definitions

For the purposes of this Code of Practice, the following definitions apply:

Aerial base	A standard base mount that a whip antenna screws on to. The base incorporates a coaxial lead to connect the antenna to the radio.
Ancillary equipment	Any equipment required as part of the installation in addition to the radio (e.g. voltage converter).
Auxiliary equipment	Any equipment which forms additional communication functions.
Audio muting	It is a common requirement to facilitate for the in-car entertainment (ICE) audio to be turned down or switched off when speech from radio equipment needs to be heard. In addition audio from the radio equipment can be routed through the ICE audio.
Bee sting	Also known as Sportflex, a type of compact flexible roof mounted whip antenna set at an angle. These are widely used on vehicles for reception of domestic broadcasts on the in-car entertainment (ICE) system. Cellular and/or GPS antennas may also be incorporated in the base of the bee sting.
Bluetooth	A standard for short range wireless connectivity, often used for audio and control functions, but can also be used for low speed data transfer. (Also see SIM Access Profile)
Cellular Network	A radio network that provides coverage with a number of cells (individual coverage areas) linked together to allow frequent re-use of radio frequencies and provide greater traffic capacity. GSM, 3G and TETRA networks are examples of cellular networks □
Clear view area	A space left within treated glass to allow radio frequency to penetrate. This is typically for a road toll transponder that communicates with a reader as the vehicle passes through a toll booth.
Earth or ground bonding	To reduce EMC emissions levels and improve EMC immunity performance within a vehicle's electronic apparatus and systems these are electrically 'earth bonded' to a common earth platform, normally considered to be the vehicle chassis. The bond resistance can be tested with a milliohm meter to ensure the installation retains the bonding.
Equipment supplier	The supplier of the equipment to the installer, which may be a dealer, distributor or manufacturer.
Databus	Electrical systems and cabling within the vehicle used for control and communication between its various electronic modules. A typical type is the CAN bus.
Ground bond	See Earth bonding above.
Ground plane	A conducting plane of a minimum dimension proportional to the wavelength on which a panel mount antenna is fitted.
Ignition feed	A source of power that is switched on when the vehicle's engine is running. Equipment can use the ignition feed for power as it allows a reasonable current draw (check the vehicle specification before use). Compare to ignition sense below.
Ignition sense	Ignition sense can be used to determine whether the vehicle's engine is running and subsequently equipment can switch on or off as appropriate. This is different from an ignition feed, see above, as ignition sense is only a signal line and will not provide adequate

	current to power equipment.
In Car Entertainment or ICE	ICE is a generic term used to describe broadcast radio, CD tuners, navigation and computer screens and so on fitted to vehicles.
Installer	Radio equipment installation technician undertaking the work on the vehicle.
ISM Band	Unlicensed 'Industrial, Scientific and Medical' short-range radio frequency bands where the unlicensed operation requires devices to be tolerant of interference from other such devices. Typically used for 'wireless' applications such as hands free, WLAN etc.
Radiating element	Part of an antenna system that radiates (emits) the signal.
Radio system	The complete radio installation in a vehicle.
SIM access profile	This is a Bluetooth profile that allows SIM card details in a compatible device to be used (over a wireless connection) in another transceiver. Also known as rSAP
Telematics	A word typically used to describe the use of Global Positioning System (GPS) integrated with computers and mobile communications technology for automotive navigation and data systems.
Telemute	Mute system to quieten the vehicle's in-car entertainment (ICE) system when the radio or telephone system is in operation (e.g. receiving a call).
Vehicle Identification Number	A unique number typically found near or within the engine bay, also known as the chassis number.
Vehicle Supplier	May be a manufacturer, dealer or the importer of the vehicle who is responsible for placing it on the market.
Zigbee	A standard for a short range wireless mesh type network to provide connectivity and low speed data transfer between devices.

1.2. Abbreviations

For the purposes of this Code of Practice, the following abbreviations apply:

2G	2 nd Generation Mobile Network, typically GSM
3G	3 rd Generation Mobile Network, typically UMTS
ADR	European Agreement Concerning the International Carriage of Goods by Road
AVL	Automatic Vehicle Location
BABT	British Approvals Board for Telecommunications
CAN	Controller area network – a form of databus
CEN	Comité Européen de Normalisation – the European Committee for Standardization
COSHH	Control of substances hazardous to health
CNG	Compressed Natural Gas
DC	Direct Current
DoC	Declaration of Conformity
DVM	Digital volt meter
ECU	Electronic Control Unit
EEE	Electrical and Electronic Equipment
EMC	Electromagnetic Compatibility
EMI	Electromagnetic Interference
ERP	Effective Radiated Power
ESA	Electronic Sub Assembly
EsCAN	Emergency Services Control Area Network
ETSI	European Telecommunications Standards Institute
GPS	Global positioning system
GSM	Global System Mobile, Groupe Speciale Mobile or Global Specification for Mobile. ETSI European standard for digital cellular mobile telephony services, also known as 2G
GVW	Gross Vehicle Weight
HT	High Tension i.e. the high voltage circuits of the ignition system
Hz	Hertz, a unit of frequency equal to one cycle per second
ICE	In Car Entertainment
ICNIRP	International Commission on Non-Ionizing Radiation Protection
ISO	International Standards Organisation
ISO2CAR	See SOT
kHz	Kilohertz, 10 ³ Hz
LPG	Liquefied Petroleum Gas
MDT	Mobile Data Terminal
MDU	Mobile Data Unit
MHz	Megahertz, 10 ⁶ Hz
MOT	UK 'Ministry of Transport' test – a periodic check for vehicle roadworthiness required by law
NAPFM	National Association of Police Fleet Managers
OBD-II	On board diagnostic socket
PBR	Professional/Private Business Radio (also known as PMR)
PC	Personal Computer
PDA	Personal Digital Assistant

PMR	Professional/Private Mobile Radio (also known as PBR)
PPE	Personal protective equipment
PTT	Press to Talk
RF	Radio Frequency
RFI	Radio Frequency Interference
RSSI	Received signal strength indicator
RX	Receive
SAP	SIM access profile
SIM	Subscriber identity module
SOT	Also known as ISO2CAR the SOT lead is used to connect aftermarket equipment that utilises a standard ISO connection to vehicles that do not have a compatible ISO harness connection.
SRS	Supplementary Restraining System
SVA	Single Vehicle Architecture
TETRA	Terrestrial trunked radio – a digital typically cellular version of PBR mostly but not exclusively used by emergency services in the UK.
TX	Transmit
VHF	Very High Frequency 30 MHz to 300 MHz
VIN	Vehicle Identification Number
VSWR	Voltage Standing Wave Ratio
UHF	Ultra High Frequency 300 MHz and 3 GHz (3000 MHz).
UMTS	Universal Mobile Telecommunications System, 3G or third generation digital cellular mobile telephony
W	Watts
WEEE	Waste Electrical and Electronic Equipment
WLAN	Wireless Local Area Network

2. Guidelines for safe & legal installation of equipment

The installer has a responsibility to ensure the safety of the vehicle has been maintained once work to fit the equipment has been completed.

This responsibility remains with the installer for the work undertaken and may not be transferred. Having the customer sign off after the job completion does not transfer liability for safety.

Due consideration must be taken by the installer to ensure that safety is not compromised by any customer demands, see section 2.3.

See Appendix B for a list of reference documents with regards to the process of installation covered in FCS1362:2010.

See Appendix C for a list of organisations that may be able to supply further information relating to installation of mobile radio equipment.

Up to date information can be found at the supplementary FCS1362:2010 website

<http://www.fcs.org.uk/MemberGroups/Installers/FCS1362Links.aspx>

Section 6.2 lists the requirements of the Highway Code with regard to use of the radio equipment in the vehicle while driving.

2.1. Insurance

The installer must have adequate insurance to cover against any reasonable claim or liability with the level of insurance cover in line with current insurance recommendations. Evidence of the insurance cover must be provided on request.

2.2. Legal compliance requirements

Equipment installed into vehicles must be compliant with regulatory requirements.

2.2.1. Compliance markings

The 'e' approval mark can be lower or upper case (e or E), and consists of the following:

Lower case 'e' in a square or upper case 'E' in a circle with a number after denoting the country in which the approval mark was granted (in this example 4 for Holland). In the vicinity of the symbol are the 'sequence number' and 'base approval number' separated by a single space making up the type approval number for the equipment. Numbers shown here are just examples.



10	03 2439
33	00 1628



03 829

The CE mark or symbol is:



2.2.2. Compliance requirements, new equipment

This section deals with new equipment being installed into vehicles.

2.2.2.1. New equipment for vehicles or motorcycles

For installations of new – see below for legacy – electrical or electronic equipment or systems into vehicles or motorcycles, there are two scenarios:

- 1) For equipment which is connected only to the vehicle's primary (i.e. 12V or 24V) power supply, the equipment or system must be marked with either a "CE" mark or a type approval mark ('e' mark).

2) For equipment which has a connection to one or more of the vehicle's data buses (e.g. ECU, CAN bus), the equipment or system must carry a type approval mark ('e' mark).

Vehicle data buses, especially the CAN bus, also control certain safety functions. Connection to such a data bus must be done in a proper manner with suitable equipment in order to maintain the integrity of the bus in question.

It is recommended that the advice of the vehicle manufacturer is sought before making such electrical connections to data buses, see section 2.7.

For equipment which is CE marked as per 1) above, the requirement is that the Declaration of Conformity (DoC) must demonstrate that the equipment has fulfilled the EMC requirements from the relevant parts of the 2004/104/EC Automotive EMC directive. Therefore, when the equipment is CE marked, it should be verified by the installer that this condition has been met.

- Verification can be done by requesting copies of the equipment's declaration of conformity from the equipment's manufacturer, supplier or importer
 - Either
 - Look for a phrase in the declaration of conformity similar to "The product is in compliance with the essential requirements of Annex I, 3.2.9 of the 2004/104/EC Automotive Directive"
 - And/or
 - Check the scope of the standards listed in the declaration to which the equipment meets match the Automotive Directive requirements.

See Appendix I for an example Declaration of Conformity

2.2.2.2. New equipment for buses, trucks & agricultural vehicles

For installations of new radio equipment into buses, trucks and agricultural vehicles registered for road use the presence of an 'e' approval mark is not legally required but is recommended.

See section 2.2.4 below for more information on specialised vehicles.

2.2.3. Compliance requirements, legacy equipment

For legacy equipment, i.e. second hand or that which is being moved from one vehicle to another, provided the equipment was first taken into service before October 1st 2002, there is no legal requirement for any compliance marking.

2.2.4. Specialised vehicle compliance requirements

Vehicles which fall into the following categories:

- carrying dangerous goods (such as petrol, gas, fertiliser or sugar)
- subject to ADR
- emergency service vehicles
- agricultural equipment
- mobile machinery
- hybrid, electric and gas-propelled vehicles

may be subject to further safety regulations e.g. specific intrinsically safe and petrochemical specifications. In the case of the first two in the list, and in the interest of safety, the instructions and advice from the Energy Institute must be followed. See appendices B and C for sources of information in this respect, see section 2.2.5 for further requirements with vehicles carrying dangerous goods.

Motorcycles are also classed as special vehicles and appropriate advice should be taken as per section 2.2.8.

2.2.5. Compliance for vehicles carrying dangerous goods

Any installation in a vehicle intended for the transport of dangerous goods (such as petrol, gas, fertiliser or sugar) must comply with both the European ADR regulations and any relevant UK code of practice for that industry.

Petroleum-carrying vehicles should be installed in accordance with the documentation published by the Energy Institute entitled:

“Recommendations for Radio Communications Equipment and its Installation in Petroleum Road Tankers” (ISBN 9780852933916).”

Contact the Energy Institute for further information from the address in Appendix C.

The recommendations are intended to minimise the risk of radio frequency induced sparking in equipment that may be close to or mounted on the vehicle. It provides guidance for the installation of any radio communications equipment and any auxiliary/ancillary devices that are permanently mounted in the cab of a petroleum carrying vehicle. The requirements are also that under fault conditions, the radio equipment enclosures cannot raise to voltage potentials and/or temperatures that may be a source of ignition.

2.2.6. Compliance for ambulances

Equipment installed in ambulances must be type approved.

Ambulances, or vehicles modified or adapted to carry a stretcher, are subject to the Medical Devices Directive and have a specific harmonized standard BS EN 1789:2007. This directive defines additional health and safety requirements and to avoid a possible compromise of the vehicle's CEN compliance certification.

Advice should be taken before fitting equipment to these types of vehicle.

See also section 2.7.1 detailing 'SVA' requirements for emergency response vehicles.

2.2.7. Other specialised vehicles

Where equipment is installed into vehicles or tractors fitted with machinery it must be CE marked. Mobile machinery must comply with the 2006/42/EC Machinery Directive. This directive defines additional health and safety requirements and to avoid a possible compromise of the vehicle's CEN compliance certification advice should be taken before fitting equipment to these types of vehicle.

2.2.8. Compliance for vehicles with less than four wheels

Two or three wheeled vehicles and quad type vehicles, where the driver is exposed, are subject to similar legislation to motor cars. Due to their specialised nature it is recommended that expert advice be taken before fitting to these vehicle types, including:

The installer should check the equipment's declaration of conformity provided by the manufacturer, supplier or importer to satisfy that the equipment meets the requirements for two or three wheeled vehicles and quad type vehicles.

Two and three wheeled vehicles plus certain four wheeled non bodied types (quad bikes) are currently subject to their own EMC legislation covered by the 97/24/EC directive. The Automotive Directive 2004/104/EC, or “e” marking, therefore does not apply to these vehicles or aftermarket equipment fitted to them.

The 97/24/EC directive Chapter 8 deals with EMC requirements and has similar test limits to the Automotive Directive but different test methods. Aftermarket equipment specifically intended for use on these vehicles must be tested to the requirements of 97/24/EC but will not bear any compliance mark other than a trade description and manufacturer's name.

97/24/EC also states that aftermarket equipment not specifically intended for these vehicles, for example a general purpose device such as a flasher unit or other device normally fitted to car, can be used providing it meets the requirements of the generic EMC directive 89/336/EC, now superseded by 2004/108/EC, and is CE marked.

Note that 97/24/ EC does not call for aftermarket equipment which falls in to this category and is CE marked to use the emission limits from the Automotive Directive as in the case of CE marked equipment fitted to cars.

The EMC requirements for these vehicles are currently under review and it is understood that they will eventually be similar to the Automotive Directive 2004/104/EC.

2.3. Legal requirements for installation work

Installation of equipment must be in conformance with the Road Vehicles (Construction and Use) Regulations 1986 and in particular Regulation 100, which is a general provision that states "The vehicle shall be safe".

Any modification to the vehicle must be performed in such a way that it does not create a condition where danger is likely to be caused to the driver, passengers or other road users.

There should be no rough, sharp or protruding edges that could be impacted by the vehicle's occupants in an accident. The full details of the requirements placed on the vehicle manufacturer are defined in EC Directive 74/60/EC and UNECE Regulation 21 (see Appendix B).

The controls, displays and cabling including any microphone/handset lead of the installed equipment must never obscure nor obstruct instruments, vehicle controls or the swept area of the windscreen; neither should their operation distract or impede the driver. See Appendix H for information on the windscreen swept area.

If the driver is the prime user of the equipment all necessary controls should be positioned within reach of the driver but not in such a way that the driver's attention is distracted from the road or that the view of the road is obscured. The driver's view of the road scene should be unimpeded as in accordance with ISO 4513 and MOT guidance and any relevant legislation such as UNECE Regulation 125.

Any equipment and its position should also conform to the requirements of any relevant legislation such as 74/60/EC Directive on Interior fittings of motor vehicles (see Appendix B).

See section 2.5 for guidance on locating equipment.

2.3.1. Use of equipment & vehicle supplier's instructions

For new vehicles approved after July 2006, there will be an obligation on the vehicle manufacturer to make publicly available information about the correct installation of after-market mobile radio equipment whose frequency, power level and suitable antenna positions has been included in the vehicle type approval.

The installation procedure must include verifying whether such information is available for the vehicle by using all reasonable attempts to obtain it, possibly in conjunction with the customer.

The installation information may be in the vehicle handbook, on a website or in leaflets available from dealers or importers.

The information, once obtained, should be followed during the installation procedure.

For vehicles type approved prior to July 2006 it is not obligatory to provide installation information for radio equipment. Approved mobile radio equipment intended for vehicle installation, however, must be supplied complete with the instructions for installation.

Where the equipment installation instructions and vehicle installation instructions conflict, advice should be sought. If vehicle installation information is unavailable the equipment installation instructions should be followed, taking into consideration the guidance in this document where ambiguities or situations specific to the vehicle exist.

2.3.1.1. Transmitter power output & definition of higher power

For all installations the transmitter power output must not exceed the vehicle manufacturer's imposed power limits as per section 2.3.1. This is particularly important for higher power and PBR radio installations.

Higher power is defined as equipment utilising 10 W or greater RF output.

2.3.1.2. Equipment & vehicle supplier's warranty

Installation of mobile radio equipment to any part of the vehicle other than an authorised connection or mounting point may invalidate the vehicle warranty. If there is doubt the vehicle or equipment suppliers should be consulted. When provided, the vehicle manufacturer's radio equipment installation instructions should be used as the prime guide.

2.3.2. Disposal of electronic equipment and batteries

The responsible disposal of Waste Electrical and Electronic Equipment (WEEE) and batteries is set down by the following legislation:-

- Environmental Protection Act 1990 (Section 34: Duty of Care)
- The Waste Electrical and Electronic Equipment (WEEE) 2002/96/EC Directive
- 2006/66/EC Battery Directive

Other environmental and health and safety legislation works with the above examples to ensure that the requirements for all such waste disposal are managed correctly and safely.

Under the terms of the WEEE and Batteries directives, businesses (including installers) which sell Electrical and Electronic Equipment (EEE) and/or batteries are classed as retailers/distributors.

The WEEE directive places an obligation on retailers/distributors who sell to 'private householders' (residential customers) to ensure that their customers can return their WEEE free of charge. The Vehicle Certification Agency (VCA), see Appendix C, is responsible for ensuring that retailers/distributors meet their obligations.

The batteries directive places an obligation on any distributors of portable batteries or accumulators (who sell over 32kg per annum in an individual store, online or by mail order) to provide a battery 'take back' facility, free of charge to anyone with used batteries to dispose of. The VCA is again responsible for ensuring that these obligations are met.

Further guidance on these obligations and how to meet them can be found via the FCS website <http://www.fcs.org.uk/MemberGroups/Installers/FCS1362Links.aspx>

Installers who do not sell EEE and/or batteries are under no obligation to provide disposal facilities. Installers should however be aware that if they agree, as part of a contract, to dispose of WEEE and/or batteries they may incur charges associated with the disposal.

Installers should therefore assess the situation and if necessary include an allowance for equipment disposal when agreeing the terms of new business.

2.3.2.1. Disposal by the manufacturer

In the United Kingdom the WEEE directive has fully applied to manufacturers, importers, retailers, distributors, business users and consumers since July 2007.

For recently manufactured equipment; manufacturers, retailers, branders and importers are required to operate a free WEEE take back service when their products are being purchased to replace existing equipment on a like for like basis.

Further guidance can again be found via the FCS website <http://www.fcs.org.uk/MemberGroups/Installers/FCS1362Links.aspx>

2.3.2.2. Disposal through membership of an approved compliance scheme

Installers obligated to dispose of WEEE and batteries must do so through an approved compliance scheme in the UK. Further guidance can again be found via the FCS website

<http://www.fcs.org.uk/MemberGroups/Installers/FCS1362Links.aspx>

2.3.2.3. Disposal by a local authority

Local authorities may dispose of WEEE related waste to businesses by special arrangement.

2.3.2.4. Secure disposal

Items of secure (encrypted) equipment, such as PMR or Emergency Services radio, must be disposed of securely under the terms imposed by the Government regulatory authorities.

The United Kingdom Data Protection Act 1998 requires that procedures are followed for the secure disposal of any equipment and storage media that may contain personal data (e.g. CCTV images, stored location information and so on). It may be necessary for the installer to ensure correct protocol is adhered to for the handling of such data and the media on which it is stored (hard drive, memory cards etc).

2.4. General safety during installation

Care should be taken during all phases of the installation and, where applicable, de-installation process to prevent danger to people and damage to the vehicle, equipment and materials.

2.4.1. Safety of personnel

Any person installing mobile radio or any other equipment into motor vehicles must be mindful of personal safety and safety of others at all times.

To ensure suitable and safe conditions for the installer, allowing a good quality installation to be safely completed, work undertaken shall be done and take place in a suitable dry and well lit location and/or facility all in accordance with the Health and Safety at Work Act 1974 and its subsequent amendments. See Appendix B for information regarding Health and Safety at Work Act legislation.

Risk and safety assessments should be undertaken to conform to the relevant legislations to show that the working environment is safe. For example working on large vehicles could result in environments that fall under the 2001/45/EC Working at Heights Directive.

To meet the obligations of the Provision and Use of Work Equipment Regulations 1998 (PUWER) installers should have adequate information, instruction and training for the tools and equipment being used. Equipment should also:

- be suitable for the intended use,
- safe and maintained in a safe condition
 - inspected to ensure this remains the case;
- accompanied by suitable safety measures, e.g. protective devices, markings, warnings

2.4.2. Working environment

Where applicable specific on-site registration, risk assessment and site access times must be adhered to, along with any requirements for clothing. In addition, a 'Permit to Work' will be necessary when working on sites controlled by other organisations to control risk.

2.4.2.1. Safety on specific installation sites

Certain installation locations have restrictions on work that can be undertaken on site. Before commencing work it should be confirmed with the relevant Safety Officer or some other responsible person that installation work complies with applicable safety regulations. Where applicable a 'Permit to Work' should be in place to demonstrate risk assessment has been done.

2.4.3. Clothing

Appropriate clothing should be worn so as not to cause a hazard to the installer or damage to the vehicle. Suggestions are:

- clean overall/dust coat, free from unprotected sharp buttons and zip fasteners
- tools removed from pockets

- watches or other metallic items such as jewellery that could damage paintwork, or come in contact with the battery supply, are removed. If, for example, a ring cannot be removed it should be covered with suitable insulating material

Special clothing should be worn if required, i.e. high visibility jackets, safety shoes, etc. Personal protective equipment (PPE) should also be used if required (for example protective goggles worn if drilling a hole).

2.5. Locating equipment

UNDER NO CIRCUMSTANCES MUST INSTALLED EQUIPMENT BE LEFT LOOSE IN THE VEHICLE. IT MUST BE SECURELY MOUNTED IN POSITION see section 2.6.1

The equipment must be located in such a position as to be suitable for use by occupants of the vehicle without compromising safety. See section 2 regards installer obligations.

Equipment should be located in such a manner that:

- The equipment and associated cables are not susceptible to damage during use
- Ventilation for the equipment is not restricted
- Equipment cannot be exposed to water damage
- Access is not barred to vehicle items in the load storage area, such as wheel jack, fire extinguishers, spare wheel etc., by virtue of the equipment's location or mounting arrangement
- Connections to the equipment should be easily accessible so it can be removed for operation in transportable mode, or for repairs and servicing
- The installation complies with legal requirements in section 2.2

Use the 'windscreen swept area' diagram in Appendix G to ensure the driver's view is unimpeded.

All other items associated with the installation (for example Bluetooth devices, handsets and PDAs) should be secured.

Where a hand portable or transportable unit such as a laptop or PDA is to be installed in a vehicle the correct vehicle/car adapter kit must be used.

2.5.1. Locating equipment & cables in vehicles fitted with airbags & SRS

Most vehicles are fitted with driver and passenger airbags, seat belt pretensioners and other SRS. These safety items activate in the event of an accident and can be located in the steering wheel, under the dashboard fascia and are often also in other locations, for example sides of seats, front pillars and side ceiling.

Airbags will affect the install location of equipment and associated cabling as consideration must be given to what happens when an airbag deploys. The equipment and its cabling must not impede the airbag operation and inflation.

The vehicle instruction manual and, if necessary, vehicle manufacturer should be consulted in case of doubt over the location of airbags and their inflation in the event of an accident.

Care must be taken during install to avoid any possibility of inadvertently triggering the airbag or SRS equipment.

Also see section 2.9.2.2 regarding seat mounted airbags.

2.6. Fixings, connectors and tools

It is the responsibility of the installer to ensure that all equipment is safely installed and fixed securely.

2.6.1. Fixings

The fixings supplied with the device by the equipment manufacturer may not always be suitable.

All fixings must be left so that there are no sharp protrusions in order to avoid injury hazards, see section 2.3.

Consideration should also be given where the equipment is to be fitted into an area of the vehicle that may be occupied by passengers. Some specialist vehicles will require the equipment to withstand specified g-force to avoid equipment breaking loose and causing injury to passengers in the event the vehicle is involved in an accident.

2.6.1.1. Fixing types

The type of fixing to be used will depend on the size and weight of the equipment to be secured, the material being fixed to and any loading likely to be put on the equipment and fixings when the vehicle is in use.

In many cases simple self tapping screws will suffice but are not recommended as prime options when fitting items of relatively high mass, for example transceiver main units. In addition the use of self tapping screws will need to be reviewed if the fixings are subject to an additional load, i.e. equipment fitted to the underside of a shelf or to a vertical wall or bulkhead. With the use of self-tapping screws care must be taken because they can work loose.

Bolts, washers and nuts should be used in preference. Wherever possible bolts with locking nuts, plain nuts with shake-proof washers or hank bushes should be used, particularly where the fixing is for a heavy item or where it may be subject to rough handling.

Plastic fixings should meet the flammability requirements imposed by the type of vehicle the equipment is being fitted to.

2.6.1.2. Methods of fixing equipment

Methods of fixing equipment can include:

- Screw/ bolts with locking nuts or plain nuts with shake-proof washers are the preferred method to be used, particularly where the fixing is for a heavy item and/or where it may be subject to rough handling
 - This method may not always be practicable unless both sides of the holding surface are accessible
- Rivet nuts offer a stronger solution than self tapping screws. Rivet nuts come in various types and provide a blind nut or a threaded stud
 - These fixings often require special tools for fitting
- Self tapping screws are acceptable where a strong and secure surface is available to screw into, and the back of the screw does not protrude into an accessible area leaving a sharp point that may cause injury or damage.
 - Be aware that self-tapping screws can work loose
- Self tapping screws combined with flat nuts, or spring nuts may be used where fixing to softer or thinner materials and where the screw alone would not offer sufficient grip.
- Rivets provide a more permanent fixing and so consideration needs to be given with regards to the servicing needs of the equipment being installed.
 - Not generally suitable for use because of this reason

Precautions should be taken on all of the above to avoid the fixings working loose with vibration. The use of shake proof washers, locking nuts or flat nuts is recommended.

Corrosion resistant fastenings should always be used in areas exposed to the elements, for example: stainless steel nuts & bolts.

2.6.1.3. Cable retention & tidying

Consideration should always be given to ongoing maintenance of equipment, so methods of retaining or tidying cables should be chosen with this in mind.

- Where cables are in a protected environment then simple 'P clip' type cable clamp fixings can be used to hold the cables in place. Cable ties can be used to secure cables together between the cable fixings. This allows for maximum access to the cable loom.
 - Cable ties should be cut off flush to avoid sharp edges.

- Avoid running cables in parallel
 - Especially true for radio equipment antenna co-axial cables
- Where cabling is either open to the elements, or accessible within a vehicle, it will need protecting.
 - Solid trunking will offer maximum protection to the cables where the vehicle type allows its use
 - Spiral binding is flexible and easy to fit but probably least friendly for servicing equipment as it may need to be unwound just to replace one cable. Over time spiral binding may retain, or memorise, any bends in the loom thereby making it difficult to refit neatly once removed.
 - Split trunking allows better cable access than spiral binding but can be unsightly if not fixed properly.

It is best practice, where possible, for cables from equipment that carry low currents, i.e. signalling and /or control connections but not power cables, to follow the existing vehicle looming. . This keeps wiring intuitive and easy to find for servicing.

Taping up long lengths of cable looms with insulating tape is not acceptable on the basis of severely hampering the ability to service or replace cables within the loom.

2.6.1.4. Connectors & joining cable

The connection type used will depend on how cables are to be joined together, joining into an existing loom or cable, or joining two cables together end to end.

As a general rule plastic auto electrical snap lock splicing connectors that cut into the cable's insulation should not be used as a connection method.

2.6.1.4.1. Joining two cables

Suitable methods of joining cables include:

- Soldering
 - this method requires more skill than crimping and so it is open to more mistakes.
 - Soldering, particularly with gas powered irons, may not be allowed in certain environments. Caution must also be taken where a gas soldering iron has a hot air vent which could easily cause damage to the insulation of other cables or the environment around the area of use.
 - Soldered joints must always employ a mechanical aspect, twisting cables together for example, to give strength to the joint.
 - The join should have any sharp elements such as protruding wires cut off, and the join must always be covered to seal the whole joint using:
 - Heat shrink tubing. This is the preferred method of insulating as it provides excellent all round insulation and does not react badly to moisture or typical seasonal temperature changes. Non-adhesive heat shrink tubing can be used inside a vehicle but it is recommended to use an adhesive lined heat shrink tubing if the wire is exposed to the elements.
 - Self amalgamating tape. This can provide an excellent water tight seal and can withstand exposure to many elements including corrosion and UV.
 - Insulation tape which is then wrapped in a cloth tape. This will keep the insulation tape in place over time but still provide excellent insulation.

It is not acceptable to attempt to seal a soldered joint by using insulating tape or a cloth tape on its own. Insulation tape is prone to losing its adhesive properties over time and through exposure to moisture and varying temperatures. Cloth tape, used in most automotive vehicles, is used as a looming tape and is not an insulator. Cloth tape is designed mainly to create neat cable looms and reduce the noise of these looms if they are in contact with any surface in a vibrating environment.

- Crimped (butt) connectors
 - An acceptable method provided the correct size connector is chosen and the proper ratchet tool is used
 - These are only suitable for use inside a vehicle where the connector is not exposed to the elements

- Heat shrink splicing
 - These come in two types and have a heat shrink outer casing making them acceptable in areas where the connector may be exposed to the elements
 - They generally follow the same colour code for wire size as standard crimps, i.e. red, blue and yellow
 - Crimp versions require the correct crimp tool to be used before the outer casing is shrunk using a heat gun.
 - Solder versions are self contained with pre fluxed solder within a transparent heat shrinkable tube.
 - They just require a heat gun to fit
 - Combine a soldered, strain relieved, encapsulated termination for weather proofing and can be used on sensitive low temperature wires such as PVC.
- Specialist crimp connectors
 - Many specialist connectors incorporating crimped connections in a clamped housing are becoming available and some vehicle manufacturers specify these for any connections into the vehicle wiring loom.
 - These connectors can offer strain relief and protection against the elements.

2.6.1.4.2. Joining, or cutting into an existing loom or cable

This is typically the case when sourcing an ignition sense or ignition feed within the vehicle.

When joining into an existing cable the only acceptable method of joining is to solder. This method requires a reasonable amount of skill and so it is open to mistakes if care is not taken.

Soldered joints must always employ a mechanical aspect, twisting cables together for example, to give strength to the joint.

- Cut around 20mm of insulation from the cable being tapped into and tin the conductor.
- Twist the new tap wire around the exposed conductor and solder.
- Any sharp elements such as protruding wires should be cut off.
- Seal the joint with self amalgamating or insulation tape wrapped in a cloth tape as described in section 2.6.1.4.1 above.

2.7. Connecting to vehicle data bus

Many vehicles now incorporate an on board data network such as CAN bus and don't have a conventional ignition sense signal. Here the use of CAN bus interfaces or adapter modules, sometimes plugged into the OBD-II socket, may be the only means of acquiring an ignition sense signal. These modules provide a switched sense output by interpreting the CAN bus data.

The vehicle manufacturer should be referred to before connecting into the CAN bus and any interface devices should be compliant with the requirements in section 2.2, i.e. the interface module must carry 'e' mark certification, so as to retain the safety integrity of the data bus.

If it is necessary for an install to require joining into the existing CAN bus loom without the use of an adaptor it should be done using the method described in section 2.6.1.4.2.

2.7.1. Single Vehicle Architecture

A project known as the 'One Box' 'Single Vehicle Architecture Project' (SVA) is, at time of publication of FCS1362:2010, nearing completion.

This SVA Project, which is supported by the emergency services and manufacturers, is intended to create a standard vehicle infrastructure. A vehicle complying with the SVA Criteria will have, in essence, an intelligent distributed power supply and a control network using the Emergency Services Control Area Network (EsCAN).

SVA invokes some constraints on installation:

- SVA allows only a small range of industry standard connectors to be used

- Installers converting vehicles to the SVA Criteria must install to the SVA requirements using equipment that complies with the Criteria
- Installers adding equipment to a SVA compliant vehicle must ensure that the additional equipment is compliant with the SVA Criteria and take care that the changes to the vehicle undertaken when fitting do not invalidate the vehicle's SVA compliant status

Additional information on the Standard, the EsCAN, the SVA Criteria and the permitted range of connectors can be obtained from the NPIA Automotive and Equipment Section, see Appendix C.

2.8. Antenna mounting safety

In accordance with the requirements of the Automotive EMC Directive, the vehicle manufacturer's instructions with regard to antenna positioning must be used as the prime source of guidance.

It is the responsibility of the installer to reasonably determine whether the manufacturer's information is available as per section 2.3.1. Should this information be unavailable, then the antenna manufacturer's information must apply. If, however, neither source of installation guidance is available, then the antenna should be installed in accordance with this code of practice, see section 4.2.

2.8.1. Antenna physical hazards

To avoid any possibility of injury from RF burns, antennas should not be touched with the radio equipment switched on. It may be worth informing the end customer of this as per section 6.2.

A hazard exists with whip antennas in relation to eye and facial injury; consideration should be given to minimising this risk when choosing the antenna type, its mounting position and use.

2.8.2. Antenna location safety

The antenna must not be located where

- it could distract the driver when the vehicle is in motion
- the antenna whip can of its own accord hinge down and protrude from the vehicle thereby causing a hazard to other road users and pedestrians.
 - A whip antenna mounted on the boot lid will be horizontal when the boot is opened presenting a danger of injury to the eyes or face. The vehicle's end user(s) must be made aware of this potential hazard.

2.8.2.1. Electromagnetic and radio frequency interference

Full consideration should be given to the positioning of mobile radio equipment to minimise electromagnetic interference (EMI) and radio frequency interference (RFI) between the mobile radio equipment being installed and the vehicle electrical and electronic systems. This is particularly relevant to the positioning of the antenna and routing of its coaxial cable.

2.8.2.2. Radiating antenna location safety

Care should be taken when locating radiating antennas so that the radiated field does not pose a risk to the end user, occupants of the vehicle or those who may be in the vicinity of the antenna when the vehicle is stationary.

For guidance refer to the equipment and antenna manufacturers guidelines as well as Health Protection Agency's ICNIRP guidance, see Appendix C.

Also refer to section 4.2.3.2 regarding refuelling areas on the vehicle.

2.8.2.3. Antenna height and length safety

The length of the antenna should be considered with regard to how it affects the overall vehicle height, particularly where height restrictions may be encountered, for example car parks, overhead cables, trees etc.

If the antenna contacts any low height object damage to the vehicle can be reduced by fitment of a shock spring.

A low profile antenna type may be more suitable and is preferable to mounting the antenna on the side of vehicles; particularly high sided vans.

If a whip antenna is cut to length a protective cap must be securely fitted. Do not leave a sharp, uncovered point at the top of the rod.

2.8.2.4. Magnetic base antenna safety

The magnetic base must be of a suitable size for the antenna and vehicle operating speed. If necessary consult the antenna manufacturer for the application data to ensure suitability.

The base

- must be directly placed on a flat area of steel
- should not have any other material inserted between the magnetic base and vehicle body other than a protective pad or boot supplied by the antenna base manufacturer. This is to avoid reduction in the magnetic retention strength and any effect on the coupling to the ground plane

2.8.2.5. On-glass antenna safety

On-glass antennas must be:

- securely fitted and fixed as per manufacturer's instructions
- located such that driver visibility is not impaired
- mounted outside of the swept area of the front or rear windscreen, see Appendix H.

2.8.2.6. Antenna safety on motorcycles

When an antenna is to be installed on a motorcycle consideration should be given to the type and position of antenna to minimise any safety hazard to the rider, pillion passenger, other road users and pedestrians (e.g. use of a flexible whip type antenna).

2.9. Precautions when working on vehicles

If there is any doubt over safety seek expert advice.

2.9.1. Electric powered and hybrid vehicles

Caution should be exercised when working on this type of vehicle due to the presence of high energy potentials from a large bank of batteries.

The location of the isolation switch should be noted and in the interests of safety the supply should be isolated before work on the vehicle begins.

To ensure that any adverse effect on existing vehicle equipment is avoided advice on the correct isolation procedure should be obtained from the vehicle manufacturer.

Note that on some hybrid vehicles utilising both an internal combustion engine and a battery-powered motor for propulsion power cables carrying up to 500 Volts may exist. Before working on vehicles of this type ensure that the route of high voltage cables has been identified, and if possible isolate the battery supply. If in doubt, seek advice from the vehicle manufacturer.

2.9.2. Vehicle battery disconnection

Some electronic equipment fitted to vehicles may malfunction or require resetting when disconnected from the power source, see section 2.9.2.1. It is therefore recommended that where possible but without compromising safety the vehicle's battery is not disconnected.

If the battery remains connected while installation work is carried out then adequate safety precautions must be taken to prevent any damage to existing electrical circuits and to ensure the safety of the installer. Note that some vehicles carry more than one battery.

Always refer to the vehicle manufacturer for guidance regarding the vehicle battery and safely working on the vehicle.

2.9.2.1. Battery disconnection and existing electrical and electronic equipment

If a vehicle battery is disconnected problems may occur with existing electrical/electronic equipment in the vehicle such as:

- engine management systems and other in-vehicle ECUs
- vehicle alarm systems
- in-car entertainment units and any other after-market devices fitted with an anti-theft security code.
 - Disconnecting ICE from the battery supply and/or removal of the ICE may have some other consequences, see section 4.5.1.
- other electrical devices, such as airbag warning lights and isolation switches.

There may be loss of functionality and/or loss of configuration data with any of the above. Consult with the customer, vehicle's handbook and any equipment instructions to ensure the necessary information is available, for example the correct anti-theft security codes, to make any such affected equipment function correctly once the battery is reconnected.

2.9.2.2. Battery isolation and seat mounted airbag

If removing a seat which contains side impact airbags, seat belt pretensioners or other SRS the vehicle battery should be disconnected for safety. Before unplugging connectors associated with seat wiring time must be allowed after the battery disconnection to ensure that any capacitors in the airbag or SRS circuitry have fully discharged. Check with vehicle manufacturer's guidelines.

All disturbed wiring must be reconnected prior to restoring the vehicle battery or turning the ignition on.

2.9.3. Master isolation switch

For vehicles fitted with a master isolation switch the supply to the radio equipment should normally be connected to the switched isolated side.

If, due to some practicable reason, installation of a certain mobile radio application means the master isolation switch is to be bypassed the customer must specify such in writing and this fact recorded in the installation documentation.

In vehicles subject to ADR, see section 2.2.4, the isolation switch must not be bypassed.

2.9.4. Power to installed equipment

Power should only be switched on and applied to equipment on completion of the installation. Refer to section 4.3.1 for guidance regarding installing power cables to equipment.

2.10. Recommended tools & test equipment

All tools and equipment used should be functional, suitably maintained and, if required, calibrated.

- All measurement devices and meters should be regularly checked for accuracy.
 - If accurate electrical measurement is required, the relevant test equipment must be regularly checked and calibrated against a recognised national standard.

Suggested tool and equipment requirements include:

- A good quality general tool kit including screwdrivers, spanners, socket set, pliers, etc.
- Any specialist tools relative to the type of vehicle and products undergoing an installation
 - Some types of fixings may require specific tools
 - Correct equipment removal and trim tools should be used as appropriate
- VSWR meter, see section 4.8.2
- Antenna analyser, see section 4.8.2
- Multi-meter/DVM
 - For testing earth bonding and aerial DC checks a milliohm meter may be required as a standard multi-meter may not measure low ohms.
 - An alternative to a dedicated milliohm meter is a converter that uses the millivolt range on a standard DVM to display 1 millivolt for every milliohm measured.

- Refer to section 4.8.1 for the measurement test requirements
- Measuring tape
- Power drill kit
- Cone cutter
- RF connector ratchet crimp tool
- DC connector ratchet crimp tool
- Portable soldering iron
 - Battery operated irons are preferred. Gas powered soldering irons may not be suitable for some environments or vehicles particularly petrochemical or hazardous load vehicles.
 - Open flame torches of any kind are deemed to be dangerous and a fire risk and so should not be used
- Heat gun. This is required for heat shrink materials and connectors
 - A soldering iron is not suitable for use with heat shrink materials
- Vehicle trim removal tools
- Radio removal keys
- Specialised screw or security driver bits
- Seat and panel covers to protect the vehicle during installation procedures
- Storage for any parts, screws or fixings removed during installation for later reassembly

2.11. Drilling holes

All holes and cuts made in materials

- must be de-burred with an appropriate tool
- Have all sharp edges removed with an appropriate tool

2.11.1. Preparation for drilling holes

Very careful consideration needs to be taken in the case of double skinned panels and/or structural panels as to whether to proceed with creating a hole. Check it is safe to drill through both skins and that there is access to both sides to ensure correct sealing and protection.

Prior to drilling a hole a check must be carried out as to what is located behind the material to be drilled. Care must be taken to avoid items such as petrol tanks, fuel lines, braking components, battery cables, wiring looms, air bags, electronic modules, ventilation pipes, etc.

It is recommended that no holes should be made through the under body of the vehicle. Where this is unavoidable adequate anti-corrosion precautions must be taken and the customer advised this may affect vehicle corrosion warranty.

2.11.2. Hole drilling

A mark for the point to be drilled must be made prior to drilling.

The appropriate speed of cut and bit/cutter should be selected based on the hole size and material to be worked on.

Drill bits/cutters should be fitted with a 'stop bit' to avoid inadvertently drilling beyond the required measured depth.

Drilling through carpets should be avoided to prevent snagging or pulling.

When drilling is complete, any metal swarf should be removed carefully from the vehicle to prevent scratching the vehicle bodywork.

2.11.3. Hole sealing & protection

Holes drilled through metal panels must be treated with a suitable anti corrosion treatment such as zinc based touch up paint.

Any drilled hole that may allow dirt or water through must be sealed with a waterproof, flexible sealant. Holes through which cables pass must be fitted with a suitable cable protection such as a grommet.

3. Planning, preparation and pre-installation guidance

A copy of the current FCS1362:2010 code of practice should always be available to the installer for reference.

Appendix A illustrates the installation process in a flow chart.

3.1. Planning installation requirements and customer consultation

As early as possible prior to the installation, the details must be checked to ensure that:

- the installer has knowledge or access to information about the physical layout of the vehicle plus the required information to undertake the install as per section 2.3
- equipment, fixings and tools, as per section 2.6 are available
- special requirements of vehicle or equipment are identified and arrangements made to provide for them, see section 3
- Requirements for safe working conditions are met as per section 2.4

3.2. Customer consultation

Whenever possible the principal user of the equipment should agree the correct position of the equipment's controls and displays for use.

- Note that this principal user/vehicle driver may not be the customer commissioning the install.

The customer should be consulted on the following points:

- that the proposed installation complies with any regulations or manufacturer's instructions pertaining to that class of vehicle
 - As per section 2, the installer has a responsibility to ensure the safety of the vehicle has been maintained once work to fit the equipment has been completed.
- advised of the equipment and vehicle manufacturers' installation instructions
- advised on the most suitable antenna and its optimum position available on the vehicle. This based on the particular mobile radio application and the need to comply with the vehicle manufacturer's instructions, safety requirements and the need for efficient RF performance – see section 4.2
- made aware of the fixing locations and mounts available for the items to be fitted so when the equipment is installed it will comply with the safety requirements given in section 2
- made aware of any configuration options
- asked whether an ignition switched supply to the equipment is required
- advised that holes made in the vehicle body during installation may affect vehicle corrosion warranty

Refer to section 2 regarding the need to ensure any customer requirements do not conflict with the need to retain safety and legal compliance.

3.2.1. Customer instructions for installations

The positions of the antenna, radio unit, handset, control panel, loudspeaker unit (if separate from the handset), microphone and any other supplied components and operational features (e.g. ignition sense/audio mute) should be discussed and agreed with the customer. All requirements should be clearly stated on the report.

3.2.2. Work cessation when customer wishes conflict with safety

Where the customer's wishes create a conflict with the vehicle manufacturer's advice, the equipment manufacturer's advice, current legislation or the relevant standards the customer must be informed. If it is not possible to complete the installation safely and in accordance with legislation while observing the customer's wishes, it is recommended that the installation be halted while advice is sought and it either re-scheduled or cancelled as a result.

3.3. Pre-check of mobile equipment

The equipment to be installed should be examined to ensure it meets the criteria given in section 2. Should the equipment not satisfy the requirements then the customer must be informed and it must not be installed.

It is recommended that the equipment should be tested before it is installed in the vehicle. At this stage all the basic functions can be checked.

Only a suitably qualified person using calibrated test equipment should carry out any internal adjustments.

3.4. Installation documentation

It is good practice to document installation in order to prove due diligence.

3.4.1. Job sheet

A job sheet outlines the work to be carried out and includes the installation date/time, address, vehicle details, equipment types and any special instructions applicable. See Appendix D for examples of job sheets.

3.4.2. Installation report

This forms a record of the installation or de-installation and notes vehicle condition before and after the work is carried out. It also records the equipment fitted or removed as well as functional tests undertaken.

The report acts as a certificate of compliance that confirms the installation has been carried out to the required standard and/or the customer's requirements. Additional certification may be required for specialised vehicles, see section 2.2.4.

It is recommended a multi-part form, see examples in Appendix D, is used unless an alternative is provided by the equipment supplier where one copy given to the customer and at least one retained by the installer.

Where two vehicles are involved in a job, such as moving equipment from vehicle A and install it to vehicle B, an installation report should cover both vehicles.

3.4.3. Pre-installation sign-off

The customer should sign the pre-installation report as an indication that he agrees with the vehicle inspection report and the proposed installation so the work may be carried out. In the event of no authorised person being available a note must be made of this on the report.

If defects are found prior to commencing work due consideration needs to be given to whether or not to proceed.

3.5. Protection of bodywork and interior

Before work commences the vehicle should be protected from unnecessary damage during the installation.

The customer's property should be protected throughout the installation by using clean protective covers on the seats and other areas being worked on and also by removing items from the vehicle and storing them in a safe, clean, dry place.

If any damage is caused to the customer's property whilst under the care of the installer the customer must be informed as soon as possible and details noted on the installation report.

3.6. Pre-Installation Procedure

Typical points to be checked, which will provide a record of the vehicle condition before and after installation, are included in the sample installation report forms in Appendix D.

The make and model numbers of the items to be installed in the vehicle should be recorded, and also the make, model, Vehicle Identification Number (VIN) and registration number of the vehicle.

3.6.1. Vehicle inspection

Any problems identified during the pre-installation inspection should be noted and a course of action agreed with the customer before any work proceeds.

It is recommended that a checklist be used to ensure a consistent standard of vehicle inspection is undertaken. Details of items covered during the vehicle inspection should be recorded on the report. This should include

- the physical inspection of
 - the external bodywork
 - internal trim
 - seating
- and the functioning of
 - electrical and electronic fittings both external and internal

3.6.1.1. Fuel leaks

Before starting the installation, establish the position of fuel tanks, the routing of pipe work and check there are no fuel leaks, particularly in the boot and engine compartment.

If a fuel leak is suspected or identified, installation must not continue and the customer must be notified immediately.

Observe health and safety and COSHH advice should any fuel spillage occur.

3.6.2. General aftermarket equipment

Items such as satellite navigation, air fresheners and so on that are already fitted to the vehicle should be left alone during the installation unless it is impractical to do so.

If any such item it has to be removed during installation it must only be refitted by the customer.

If the customer is not available leave the items safe and secure in the vehicle in a way that makes it obvious that its fitment should be completed and checked prior to use.

It would be an idea to record this action on the installation job sheet.

3.6.2.1. Child seats & booster seats

If possible a child seat or booster seat fitted in the vehicle should be left alone during the installation.

If it has to be removed during installation

- it must only be refitted by the customer.
- it must be made obvious to the customer that the child seat or booster seat will not be re-fitted and that it should be done prior to use.

If the customer is not available leave the child or booster seat safe and secure in the vehicle in a way that makes it obvious that its fitment should be completed and checked prior to use.

3.6.2.2. Valuables

The customer must be advised of the need to remove any valuables present in the vehicle prior to the vehicle being left and the installation taking place.

Should any valuable items be found in the vehicle during installation a note should be made on the installation job sheet, the customer informed and the items left in a suitable safe and secure place out of sight from the exterior of the vehicle.

4. Installation procedures

Ensure all component parts of the equipment to be fitted are present and in serviceable condition to enable the completion of the job.

See section 4.11 regarding de-installation should the installation job involve moving equipment from one vehicle to another.

4.1. Installation of antenna and coaxial cable

The antenna system and its installation dictate the quality of performance of the mobile communications equipment.

The manufacturer's instructions, where supplied, should be read and the vehicle manufacturer guidelines for antenna location and type should be followed as per sections 3.8 and 5.2.

Not all installations will require the fitment of an antenna as it is integral in some mobile equipment (e.g. GSM phone in-car kit without external antenna connector, Bluetooth hands free, etc.)

4.1.1. Antenna types

It is important to select the correct antenna to best match both the customer requirements and mobile network coverage.

Also see section 2.8 regarding safety considerations for antenna installation.

Generally mobile radio installations and those of higher power, for example PBR, TETRA, require a more effective antenna installation.

Table 1 - General table of antenna type to typical network performance

Type		Cellular GSM/3G/ Tracking	Mobile Radio/PBR/TETRA
1	Body Mount	Optimum performance when roof mounted – recommended	Optimum RF performance when roof mounted – recommended
2	External glass mount	Almost as good as body mount for cellular GSM/3G	Usually gives acceptable RF performance: VHF - not as good as body mount UHF – close to body mount subject to mounting location
3	Internal T bar glass mount	Fair when positioned high on screen. Should be vertical	VHF not available due to size UHF – reduced performance - should be vertical.
4	Internal tax disc glass mount	Default position at base of screen may give reduced performance especially in poor signal areas	VHF not available due to size UHF – very poor performance due to size and position.
5	Bumper mount	Location causes antenna to be very directional - not suitable for use in poor signal areas	Location causes antenna to be very directional VHF very poor performance due to size and proximity of vehicle body UHF poor performance due to proximity of vehicle body. Very directional but can be acceptable with dual-antenna systems

Antennas for terrestrial radio systems (e.g. cellular GSM/3G and mobile radio) are usually vertically polarised and need to radiate towards the horizon as the network base station will usually be located on a mast/tower or building structure relatively close to ground level.

Antennas for GPS and satellite communication systems need to have an unimpeded view to the sky. The network signal levels from satellite systems are significantly lower than for terrestrial systems so antenna positioning and orientation is usually more critical to ensure effective operation.

Covert type antennas can be either a modification of an existing body mounted antenna (e.g. bee sting) or an internally fitted unit. Internal, discreet or covert types generally have a reduced performance compared to conventional antennas due to their design and/or mounting location. Consideration should be given to their suitability for the customer's application before fitting this type of antenna. See Appendix G for information regarding antenna performance of covert antennas.

Active type antennas incorporate a powered amplifier. These are considered as an electronic sub assembly (ESA) and should carry 'e' or CE mark as per section 2.2.1.

4.1.1.1. Internal antennas

If a vehicle manufacturer states that internally radiating antennas – i.e. an antenna fitted within the interior of the vehicle – cannot be fitted then this may affect the proposed antenna type for the installation.

4.1.1.2. Antenna bases and whips

It is not advisable to mix and match antenna bases and whips from different manufacturers as this could lead to poor performance or damage to equipment due to an impedance mismatch.

4.2. Antenna installation

The antenna must be:

- The correct type for the application and frequency used by the radio equipment
- Located in the recommended position and of a suitable type for the vehicle. Refer to the vehicle and antenna manufacturer's guidelines.
- Installed correctly and, if exposed to harsh environmental conditions, sealed to prevent ingress of dirt and water.

Following antenna installation:

- All connections should be electrically tested see section 4.8.1
- Where required ensure that a VSWR test shows a satisfactory match is obtained – see section 4.8.2

Before and after replacing any vehicle trim that may have been removed to install the antenna it is advisable to carry out the antenna checks to ensure the cabling and installation has not been compromised.

Additional information on testing antennas is contained in section 4.8 and example radiation patterns illustrated in Appendix E.

4.2.1. Avoiding interference

EMC issues may occur with an antenna install in two ways:

- a) Radiated EMI - Interference may occur to in-car entertainment equipment or other vehicle electrical equipment. If possible this should be checked before final fixing of the antenna on the vehicle, see section 5.3.1
- b) The antenna may pick up noise received from the vehicle or other fitted role equipment such as light bars, GPS processors and other digital (computing) equipment and present it to the radio equipment as interference.

Repositioning, or a different type of antenna, should be considered if either type of interference occurs. It is good practice to site the antenna at the greatest distance possible from the offending equipment, and any antennas or cables it has, to minimise these EMC problems.

Also see section 4.2.5.1 regarding the antenna co-axial cable.

4.2.2. Approximate frequency to wavelength conversion

A simple formula to calculate the wavelength in metres from a given frequency is:

$$\frac{300}{\text{Frequency (MHz)}}$$

e.g. For 150MHz, $300/150 = 2$ metres

and therefore a $\frac{1}{4}$ wave is 0.5m or 50cms, a $\frac{1}{2}$ wave 1m or 100cms.

Table 2 - Approximate frequency to wavelength conversion

Band Name	Frequency (MHz)	Wavelength (cm)	$\frac{1}{4}$ Wavelength (cm)
Citizens Band (CB)	27	1100	275
Band 1	50	600	150
Low Band	80	375	94
VHF Mid/High	150	200	50
Band 3	200	150	38
TETRA/Public Safety	400	75	19
UHF 1	420	71.5	18
UHF 2	460	65	16
800MHz Band	850	34.5	9
GSM 900	900	33	8
GPS	1545	19.5	5
GSM 1800	1800	16.5	4
UMTS	2100	14	3.5
W-LAN & Bluetooth devices	2400	12.5	3.2
2.6GHz Band	2600	11.5	2.90

4.2.3. Locating antennas on vehicles

Refer to section 2.3.1 regarding vehicle manufacturers supplying specific information on antenna type and location. When available this should be used as the prime guide.

The centre of the vehicle's roof is the ideal position to achieve a good 360 degree omni-directional radiation pattern from an antenna. Any other location will affect the antenna radiation pattern, see Appendix F and Appendix G.

On-glass and window clip type antennas will always suffer some distortion to the radiation pattern due to their mounting positions usually being at the edge of the vehicle ground plane.

The antenna should be located away from any vertical structure, windscreen pillar, or any structure on the roof etc. which could act as a screen or reflector to RF.

Care should be taken when positioning the new antenna close to an existing aerial. There should be a separation of at least half wavelength for transmit frequencies below 600 MHz and one wavelength for transmit frequencies above 600 MHz. With complex multiple antenna installations the presence of other antennas on the roof, especially if operating in the same frequency band, may:

- a) Alter the radiation patterns of each individual antenna.
- b) Cause mutual interference between the radio devices that the antennas are connected to.

Antenna positions should be planned to achieve best separation between antennas while maintaining a suitably sized ground plane for each one – see Appendix F.

There will be a point where multi-coupling (antenna combining) techniques may become cost effective in maintaining performance. This should be a part of the vehicle installation design process.

4.2.3.1. Antennas and sunroofs

If a sunroof is fitted, then the antenna should be mounted at least a quarter wavelength from the opening, see section 4.2.2 for wavelengths. Care should be taken to ensure the selected position does not foul the sunroof or its operating mechanism.

4.2.3.2. Fuel filler caps

The antenna location must be a minimum of 30 cm from the edge of the vehicle's refuelling system/fuel filler cap to account for the possible effect of the radiated electrical field as a source of ignition. Consideration should also be given to the potential danger from an antenna tip being positioned at or below eye level where, for example, it could cause injury to a person refuelling the vehicle.

4.2.4. Fitting antennas

Fitting the antenna depends on the antenna type and the vehicle it is being fitted to.

4.2.4.1. Panel mount antenna

This antenna type requires a hole to be drilled in the vehicle body in order to mount the assembly. See section 2.11 for guidance on drilling holes.

Before fitting the antenna in the desired location check for adequate clearance under the panel for the cable and ensure the installation will not interfere with the structure or operation of the vehicle.

A conventional panel mount antenna is mounted vertically on a horizontal ground plane. The ground plane is a component of the antenna system provided by the vehicle's body panel.

Ideally the antenna will be mounted in the centre of a ground plane with a radius of at least one quarter wavelength at the lowest frequency band being used. On lower frequencies (e.g. low band) this ground plane radius may be difficult to achieve due to larger wavelength. In this case the antenna may need adjustment of length, usually shortened, to compensate for the smaller ground plane, see section 4.8 testing antennas.

De-burr the hole and remove an area of paint/primer from the underside of the panel to ensure a good earth connection for the antenna mount. Petroleum jelly or a similar substance should be applied to the exposed metal to prevent subsequent corrosion occurring.

Care should be taken not to over-tighten the mount as this could cause distortion of the panel.

4.2.4.1.1. Panel mount antenna on vehicle with electrically isolated chassis

It is not common but it may be necessary to install a panel mount antenna to a vehicle with an electrically isolated chassis.

Using a standard panel mount antenna in this case will compromise the chassis isolation by providing a path for a negative potential to the chassis. This isolation break down can be overcome by fitting a suitable antenna which has no direct contact between vehicle chassis and coaxial connector or cable.

In exceptional cases a DC path blocking device, also known as a 'braid breaker', may be introduced in the coaxial cable feed as close to the antenna as possible. It should be noted that these devices are usually frequency dependent so care must be taken that the unit is suitable for use at the intended frequency.

4.2.4.2. Antennas on non-metallic panels

When the antenna installation is to be carried out on a non-metallic surface:

- a ground plane independent antenna can be fitted directly to any surface (glass fibre etc.) or onto a mounting bracket which may be supplied by the manufacturer
- a standard antenna can be used with a ground plane fitted to the underside of the panel e.g. a metal plate complying with dimensions in section 4.2.3.

4.2.4.3. On-glass antennas

On-glass antennas are usually not suitable for vehicles with double-glazed screens, reflective coatings, armoured or other special glass.

On-glass antennas are not suitable for double glazed vehicle glass, glass with a reflective coating or windows fitted with fine mesh heater wires unless there is a clear aperture e.g. road toll transponder window/clear view area.

As per section 2 consult the vehicle manufacturer's recommendations before selecting an on-glass antenna to ensure the suitability of such installation.

The antenna should be mounted clear of the window heater elements, decorative coating, washer/wiper and any integral-to-glass receiver aerial if fitted.

Follow antenna manufacturer and/or adhesive guidelines to ensure the performance of the mount. Refer to manufacturer's instructions and recommendations particularly with regard to specified temperature range when fitting in cold weather. It is good practice to ensure that both the glass and the antenna mounting components are warm before fitting.

Scrupulous cleanliness must be observed and care should be taken not to touch the adhesive surfaces or the glass after cleaning prior to fixing.

Most adhesive pad material uses a pressure activated adhesive and an even pressure should be applied to the component being fitted to ensure maximum glass contact and that all air bubbles are removed.

Curing time of the adhesive pad, especially in cold weather, can take up to 24 hours.

If the vehicle will be used at high speed while the adhesive is curing it may be best to not fit the antenna element to the mount and advise the customer to attach it after the curing time is reached. The radio equipment must not be used until the antenna mount is fully assembled and it must be ensured that the customer is informed of this.

4.2.4.4. Specialist antennas

These can include combined (dual or multi frequency), ground plane independent and low profile or disguised types.

If the antenna includes a broadcast receive function it may incorporate an active amplifier that requires a 12volt positive feed. Dependent on the type of antenna and/or broadcast receiver this can be provided by one of two different methods:

- Phantom feed - 12volt positive feed via coaxial cable from the broadcast receiver
- Separate feed - a separate 12volt positive feed usually derived from a switched source output

Reference to both the antenna installation instructions and vehicle/receiver handbook may be required to determine the correct connection method.

Combined antennas may be supplied with a separate diplexer (signal splitter) unit, which should be securely fixed in a dry location.

4.2.4.5. Covert radiating antennas

Special care should be taken when considering the location of covert radiating antennas:

- Vehicle manufacturer's advice must be taken into consideration, see section 2.3.1
- The antenna should radiate sufficiently to enable effective communication with the radio network

- The antenna should be mounted, wherever possible, so as to maintain vertical polarisation
- If mounted horizontally it could incur significant cross polarisation loss and produce large null areas in the radiation pattern
- Consideration given to the attenuation of signal and radiation pattern distortion caused by being fitted behind trim material (e.g. the 'A' pillar or dashboard covering)
- A radiating antenna should be installed as far away as possible from any ECU or an airbag/SRS deployment system to minimise the risk of radiated (EMI) susceptibility problems.

The upper limit for VSWR may have to be increased for this type of antenna due to its design and mounting position. A limit of 2.0:1 is acceptable for cellular GSM/3G, but may have to be higher for specialist mobile radio types, see section 4.8.2 for VSWR measurement.

See Appendix G for information regarding antenna performance of covert antennas.

4.2.4.6. GPS antenna

A GPS antenna function is to receive only. This means that in respect of radiated EMI issues its mounting position does not have the same constraints as that of a radiating antenna.

This type of antenna is typically active with a low noise amplifier (LNA) powered by a phantom feed up the antenna coaxial cable, supplied by the GPS receiver.

Some systems can use an alternative type of GPS antenna that combines the GPS receiver and antenna in one unit and this is often referred to as a GPS mouse. This device is self contained, so there is no connecting coaxial cable and can commonly be divided into two distinct types:

- Permanently fitted and usually externally mounted - this type has a multi-core cable to connect to the terminal equipment which supplies power to the GPS receiver and carries serial data position information to the terminal.
- Portable unit – this type is generally battery powered and provides serial data position information over a low power wireless link that typically operates in the unlicensed ISM band.

Antennas for GPS reception need to have a clear view towards the sky to enable acquisition of satellite signals. The location of the antenna will have a marked effect on effective GPS performance. See Appendix E for an example E-plane diagram for a GPS antenna.

It should be noted that vehicle glass can be metallised (tinted) or have fine mesh heating elements. This will have an adverse affect on the performance of a GPS antenna and may require it to be fitted in a specific place, for example in a clear view area aperture for a road toll transponder, or even externally. Consult the vehicle and/or glass manufacturer for guidance.

4.2.4.7. Temporary antennas

These can include boot mount, magnetic mount, gutter mount and window clip types.

Care should be taken when routing the coaxial cable through door or boot openings to minimise risk of damage to the cable.

Before a magnetic mount antenna is fitted both the underside of the base and the selected body panel surface should always be cleaned so as to avoid damage to the paint work.

See section 2.8.2.4 on safety when using temporary antennas with magnetic bases.

4.2.5. Coaxial cable to antenna

A suitable coaxial cable of the correct impedance, usually 50 ohms, correctly terminated with a suitable connector should be used to provide a continuous run between the antenna and the radio equipment.

Table 2 below shows the loss figures for the most common types of coaxial cable used in mobile installations.

It should be noted that, although they may have the same type designation, such as RG58, there can be a variation in quality of construction and performance of cable from different suppliers. It is important to

check the specification with the supplier. As a guide the cable should have a minimum of 90% braid coverage

In addition to attenuation, consideration should be given to the impedance – a tolerance of $\pm 2\Omega$ at 1GHz and $\pm 4\Omega$ at 2GHz is acceptable.

It should be noted that some cable types may not be suitable for use in the higher frequency bands (e.g. above 1800MHz) – if in doubt check the manufacturer or suppliers specification.

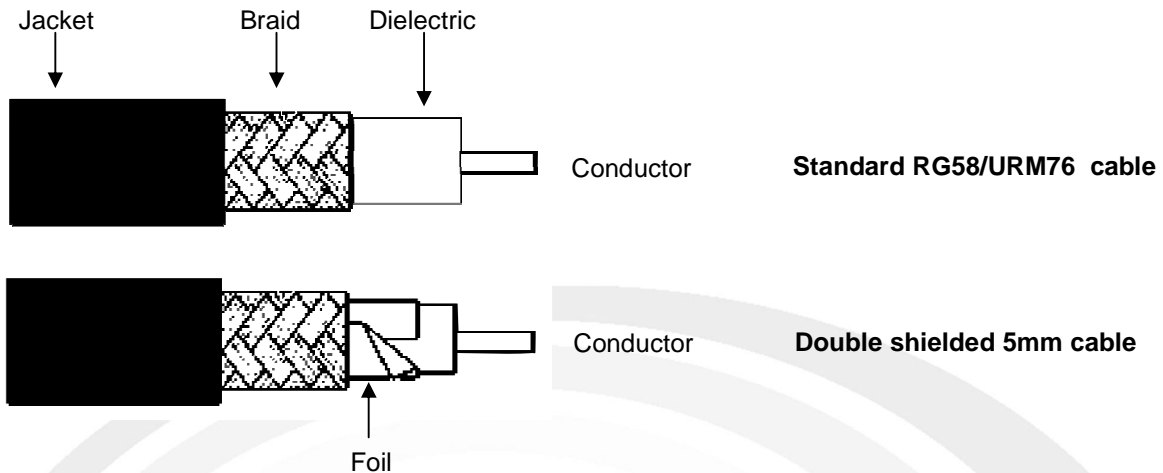

Double shielded coax cable has an additional foil shield around the dielectric which often combined with a different dielectric material, improves the attenuation performance of the cable especially at higher frequencies.

Table 3 - Coaxial Cable – Typical Loss per Metre for Different Types

Coaxial Cable – Typical Loss per Metre for Different Types							
Frequency ► ▼ Cable Type	80MHz (Low Band)	150MHz (High Band)	220MHz (Band 3)	400MHz (TETRA Airwave)	900MHz GSM900	1800MHz GSM/ PCN	2100MHz 3G UMTS
RG174 2.7mm diameter	0.2dB	0.3dB	0.5dB	0.7dB	1.0dB	1.2dB	1.4dB
3.5mm diameter Double Screen	0.15dB	0.2dB	0.3dB	0.5dB	0.7dB	0.9dB	1.1dB
RG58/URM76 5mm diameter	0.1dB	0.15dB	0.2dB	0.3dB	0.45dB	0.7dB	0.8dB
5mm diameter Double Screen	0.07dB	0.1dB	0.15dB	0.22dB	0.3dB	0.45dB	0.55dB

Excess coaxial cable should not be coiled up as this may affect the tuning of the antenna as well as producing electrical interference. It is best practice to cut the cable to the correct length and then terminate it accordingly. Some antenna kits are, however, supplied with pre-terminated connectors and it may be necessary to retain the full cable length that should be “laid out” over a larger area instead of being coiled.

If the provided cable is too short, where possible, a suitable cable of the correct length should be used to replace it. Where an extension cable is required the correct method of joining lengths of coaxial cable is the fitment of quality low loss connectors to each end of the cable maintaining the correct impedance and loss properties throughout the total length. The consequences of the additional loss should be considered

particularly at frequencies above 400MHz. It may be more effective to find a different location for the antenna to achieve a shorter cable run.

4.2.5.1. Routing of the antenna cable

Ensure that the cable is:

- properly secured but ensure that the cable is not strained or distorted, by excessive tightening of cable ties for example
- routed in such a way as to avoid sharp bends
- not run in parallel with vehicle wiring wherever possible
- routed as far away as possible from any electronic module

Ensure that any trim panels do not trap, crush or distort the cable when vehicle trim is replaced.

Additional care should be taken when installing a glass mount antenna to the rear screen of a hatchback type vehicle to allow the boot to open but to prevent damage to the cable over a period of time. This may be achieved by providing a loop of cable across the boot opening.

Special care should be taken when routing coaxial cable used with a high power radio system (see section 2.3.1.1) due to the much higher risk of causing RF interference to the vehicle's electronics.

4.2.5.2. Fitting of coaxial connectors

Fit the correct antenna connectors at each end of the coaxial cable. Crimp type connectors are preferred and should be fitted using the correct ratchet tool. Ensure that all joints are both electrically and mechanically sound and, if exposed to harsh environmental conditions, sealed to prevent ingress of dirt and water.

4.3. Installation of cables

Installation must follow the safety guidance in section 2.

See section 2.6.1.4 for joining cables etc.

Do not attach any wire or cable to the vehicle fuel system and pipes or use a common hole through a bulkhead.

4.3.1. Routing of power and control cables

For guidance on cable runs refer to vehicle manufacturers instructions where available, or, if not available, seek expert advice and specification from client or customer.

Where possible all cables should pass under carpets and through trim or mouldings in such a way as to ensure that any panels do not trap, crush or distort the cable when refitted. Use sleeving or cable protection and cable ties where required.

Cables should be securely affixed so as not to distract the driver when the vehicle is moving. Similarly adequate securing can avoid future failure due to fatigue from vibration.

Care should be taken to avoid strain on any cabling likely to cause broken connections.

Ensure that excess length of any cable tie used is cut flush with its locking mechanism to avoid leaving sharp and potentially dangerous projections.

See section 4.2.5 if dealing with antenna cable.

4.3.1.1. Grommets

Whenever the cables pass through a bulkhead, a grommet must be fitted. It is always better to use an existing hole rather than drilling another, provided it is in the right position, is large enough, and is fitted with a grommet. The quality of the original seal should not be impaired.

4.3.1.2. Routing cables

Select a route for the cables preferably away from and/avoiding the following

- vehicle wiring
- safety-related electronic components
 - e.g. ECU.
- the fuel pipe
- brake pipes
- control cables
- controls
- pedal box
- steering column
- hot components
 - Note these may be cold during installation, e.g. engine, exhaust, air conditioning etc.
- Moving parts should be avoided
 - Allow for the movement e.g. pedal travel etc.
- Under no circumstances should any cables be attached to any of these mechanical elements
 - drive shafts
 - control pedals
 - control cables
 - shock absorbers
 - brake pipes or cables
 - fuel lines

Cables should be routed and supported so that they avoid

- sharp edges
- continual bending
- stress or strain
- abrasion
- extreme temperature
- sharp bends
- creating a hazard or distraction to the occupants of the vehicle
- running parallel to power cables in electric/hybrid vehicles
- run parallel with equipment's antenna cables

4.4. Components of the installation

Typical components of a radio system may consist of the following items (see table 4 below)

Table 4 - Components of the installation

Component	Cellular GSM/3G	PBR	Tracking or telematics
Handset/Cradle	Yes	Yes	No
Slave Handset/Fist Microphone	Yes	Yes	No
Display	Yes	Yes	Yes
Hands free Microphone	Yes	Yes	Yes
Speaker	Yes	Yes	Yes
Transceiver/Junction Box	Yes	Yes	Yes
Remote Controls	Yes	Yes	Yes
Power Loom	Yes	Yes	Yes

All components should be installed in accordance with section 2 and with the principal user in mind as per section 3.2, with the following criteria met:

- driver's view of the road scene is not obstructed in accordance with Appendix H.
 - For further information see ISO 4513 and MOT legislation (Appendix B).
- is as close as practicable to the driver's field of vision
- has any required controls accessible without distraction
- allows for easy insertion and removal of handset
- does not impede vehicle controls, airbag etc as per section 2.5
- is securely mounted as per section 2.6

4.4.1. Slave handset/fist Microphone

Ensure the handset is mounted in a position such that it can be lifted to the driver's head height when in a normal seated position.

Any cabling must not interfere with vehicle controls either when in use or stowed.

Handsets incorporating displays and controls should be located as per the points in section 4.4

4.4.2. Hands free microphone

Microphones are usually directional and need to be pointed towards the user to pick up speech.

Mount the microphone on a non-resonating panel in a position ideally not more than 50cm from the user's mouth.

Ensure the microphone will work with the vehicle's sun visor in all positions and is clear of all normal driver movements.

Where possible the microphone should be installed near the front roof light cluster. Locating the microphone on the pillar near the window may result in interference when it is in use should the window be open.

Consideration must be given to avoid reflecting surface feedback to the microphone off pillars, windows and so on. This can affect the echo cancelling features of the microphone's audio pickup leading to interference and poor performance.

The microphone feed wire should be routed as per section 4.3.1.

If routing the cable past pillar mounted airbags the cable run must be arranged so that airbag deployment is not compromised.

4.4.3. Loudspeaker

The loudspeaker should be positioned to provide an unobstructed audio path to the user and in such a way to make certain that any vehicle occupant is not likely to suffer discomfort from excessive audio levels.

To avoid the possibility of acoustic feedback the loudspeaker should not point directly towards the microphone.

The distance between loudspeaker and microphone should comply with manufacturer's recommendation.

Securely fit the loudspeaker to a firm surface or panel as per section 2.6

Consider any equipment behind the panel, e.g. airbag actuator, fuel cut-off switch, and the possible adverse effect the speaker magnet's magnetic field may have on it.

4.4.4. Microphone and loudspeaker positions

Microphone and loudspeaker positions should be selected to avoid audio clipping or feedback problems that could be caused by

- the units being too close together
- the units directly facing each other
- mounting the microphone on a resonating panel

4.4.5. Distribution boxes and transceivers

Where a distribution box and or transceiver are provided as part of the radio equipment they should be securely fitted as per section 2.6

Allowance should be made for adequate ventilation for the equipment, especially with higher power transceivers.

Where the equipment requires it consideration should be given to SIM card access.

Transceivers should not be operated without a connection to a safely installed antenna as per section 4.2.

The various ancillary and auxiliary components should be connected to the distribution box or transceiver as detailed in the manufacturer's instructions and following guidance in section 4.3 on cabling.

4.4.6. Remote controls

Any remote controls, such as PTT, should be safely operable from a normal driving position as per section 2.5 and 3.2.

4.4.7. External alert facility

Where an external alert facility (an external sounder) is provided the alert must not sound like a bell, gong or siren. This is to comply with current Road Vehicle Construction and Use regulations.

4.4.8. Installation of auxiliary mobile equipment

This equipment is in addition to the normal radio communications equipment installed within the vehicle. In many cases it uses the existing voice transceiver to communicate information. Examples of auxiliary mobile equipment are given below:

- Interface
- Modem
- Data terminal equipment
 - Fax
 - PC or PDA
 - Printer
 - MDT / MDU
- Tracking and alarm systems
- Navigation systems
- Camera
- Switches and sensors
- Wireless audio connections

All auxiliary equipment installed should be suitable for use in a mobile environment, see section 2.1.

Care should be taken when interfacing with the radio equipment to ensure both systems operate correctly.

All auxiliary equipment should be securely and safely mounted as per section 2.6

It is recommended auxiliary equipment and wiring is kept away from the antenna cable of the mobile radio equipment.

4.4.8.1. Auxiliary equipment power requirements

In some cases auxiliary equipment can be powered from its own internal battery supply.

Where the equipment requires a power supply, then a separate fused supply should be installed as per section 4.6.

When ancillary equipment draws power directly from the main equipment

- consideration must be given to the rating of fuses and the existing wiring providing power to ensure each will handle the additional current demand.

- The equipment should be designed to handle the power requirements of the auxiliary equipment. See section 4.6.3 regarding fusing

4.5. Audio muting and audio routing facilities

When an ICE mute is available and asked for by the customer the compatibility of the equipment must be checked.

Care should be taken not to damage or compromise the existing wiring in the vehicle.

Depending on the equipment the muting and audio routing method may be one of the following:

- Manufacturer's built-in interface harness that will require an additional interface lead
- Vehicle specific tele-mute lead, possibly incorporating power supply lead, that connects directly into the vehicle radio wiring harness
- An interface unit on the ICE loudspeakers allowing the mobile radio equipment to use the ICE speakers
- A direct mute line allowing the mobile radio equipment to be used with its own hands free speaker
- A mobile radio equipment mute line operating a normally closed relay to switch off the ignition feed to the ICE

4.5.1. Guidelines for removal, connecting & refitting of ICE

If an ICE system is to be removed to fit a mounting bracket or to connect a mute then care should be exercised in utilising the correct and appropriate radio removal tools for that particular unit.

Always ensure that any CDs are ejected from the ICE unit before removing it, as they can become jammed if the unit is inverted with discs inside.

As per section 3.1 ensure details for reinstating the equipment, such as a security code, are available.

4.5.1.1. ICE audio integration, mute lead, ISO2CAR & SOT leads

When installing with the radio equipment a custom made unit, adapter or cable loom that mutes the ICE audio when a call is being made, which includes the constant power feed, ignition switched power feed or ignition sense and earth lead, the following checks should be made to ensure everything is compatible:

- vehicle make and model and build year
- the ICE system being connected to
- the equipment being fitting i.e. hands free car kit model
- the permanent and switched feeds should be checked
 - i.e. permanent is constant voltage and the switched feed off when the vehicle ignition is switched off
- all equipment earth connections remain earthed to the vehicle when the ignition is switched off
- correct fuses should be used in the power cables
- the fuse ratings are correct for the application
 - the cable/fuse rating of the muting device must be checked to ensure compatibility with the equipment being installed. Some high power communication equipment is not suitable to be used in conjunction with mute leads as the power rating required is higher than the ignition feed in the mute lead can provide.

No other additional accessories should be connected to any of the leads used in the audio integration installation.

The installation instructions of the lead being installed should be consulted and followed carefully at all times. Use of the lead may include specific configuration requirements so be particularly careful with this if needed.

4.5.1.2. Wiring harness checks

Once the ICE unit has been disconnected from the vehicle on the vehicle's wiring harness plug, using a multi-meter, ascertain and note the location, voltages and state of:

- the permanent live
- ground or earth
- ignition sense (if any)
- audio mute
- any other connections (for example CD changer, etc.)

In some cases when installing aftermarket equipment there may be wiring connectors which are not utilised. Ensure any unused connections are fully insulated and cannot short to other components, ground/earth or metal parts.

4.5.1.3. Warning tones & ICE

It should be noted that some vehicle models present warning tones, for example reversing sensor tones, seatbelt warning tones, etc., through the ICE system.

- The warning tones may not be presented when the ICE is muted or audio being routed through from the installed device
- The customer must be made aware of this prior to installation and it noted on the installation report form
- Correct operation of warning tones should be verified during the testing of the install see section 5.3.2

4.5.1.4. Reconnecting ICE

Once the lead is fitted, before connecting the ICE, checks should now be performed to ensure the signals and voltages shown by the tests carried out in section 4.5.1.2 (Permanent live, ignition sense, earth etc.) are replicated accurately on the correct pins.

Should the lead being fitting be pre-terminated for the equipment being installed, it should be verified that the pin-outs are correct before connecting.

Once these checks are carried out, the ICE unit may now be reconnected, refitted then tested for correct functionality.

4.6. Equipment power source

Vehicle manufacturer's instructions must take precedence where they give details on the provision of a power supply for communication and ancillary or auxiliary equipment.

Power connections should not be made to any ECU feeds under any circumstances

Vehicles are being produced with CAN bus/multiplex/fibreoptic wiring systems and caution should be taken when sourcing a suitable power supply. Also see section 2.7.1 regarding SVA.

See section 2.2.4 for specific advice on specialist vehicles.

See section 4.4.8.1 for additional power requirements should auxiliary equipment also need to be installed.

4.6.1. Equipment with high current rating

Where the equipment or multiple pieces of equipment combined have high power consumption then this may compromise the operation of the vehicle and original vehicle battery.

The vehicle should be specially adapted and the capacity of the battery and charging circuit increased to meet the current requirement of any additional equipment, for example fitting a higher capacity battery and/or the installation of a split charger and second auxiliary battery.

See section 4.6.3 regarding fusing.

4.6.2. Provision of a dedicated/permanent power supply cable

Unless otherwise indicated by the vehicle manufacturer a dedicated supply cable should be used for the mobile installation.

If the power source is from a power distribution point other than the battery it must be adequately rated so that the collective current drawn does not exceed the rating of the distribution point.

The supply cable from the radio equipment should approach the battery in such a way that when terminated the two wires cannot be inadvertently reversed e.g. one wire is shorter than the other. It is recommended that unless a moulded twin supply cable is used then the two supply lines be run together along their length in order to reduce induced noise.

4.6.2.1. Installing power supply cable

When fitting a supply cable, the following should be considered:

- heavy duty cable should be used on long cable runs to minimise voltage drop
- the cable should be of a higher current capacity than the protection fuse and the correct fuse fitted
- the cable should be as short as possible
- routing and mounting of the cable should follow advice in section 4.3.1
- the supply cable run should, where possible, be separate from that of the ICE equipment control cables, although they may pass through the same holes in the chassis and body for ease of fitting.
 - Suitable grommets must be fitted if additional holes are drilled see section 2.11
- the power cable should be sited away from ignition coil, HT circuits and ECUs, antenna coaxial cables and, where possible, other vehicle wiring.

4.6.3. Fusing

The power supply cable should only be fused in the positive power line with the fuse located as close as possible to the battery or power source.

Fuses must not be used in parallel as a means of obtaining a higher rated supply.

For external connections use water-resistant fuse holders and ensure fuses comply with the equipment manufacturers recommended rating and type.

Fuse ratings must not be increased to accommodate higher power equipment to such a point that the wiring of the vehicle and/or the equipment is no longer protected.

4.6.4. Negative Feed Connection

In the case of negative earth return vehicles, the negative power line should not be fused. It should be connected to the vehicle body as close as practical to the point at which the battery-to-body connection is made. Do not connect the negative power line directly to the battery.

For heavy commercial vehicles (>7.5Tonne GVW) only, and those vehicles with tilting cabs where the cab may be isolated from the chassis by rubber mountings, a ground point is provided by the vehicle manufacturer within the cab to provide battery to cab grounding. Generally this is located within the main fuse box. It is recommended that this point be used for installations in this instance.

With certain equipment it may be necessary to connect the negative supply line to a local earth point. **In this case an existing vehicle earth point must be used.**

4.6.5. Sourcing ignition sense

Many types of equipment have provision for ignition sense.

The ignition sense facility can enable the equipment to be powered on and off with the ignition. It should be noted that some equipment can be programmed to have a "delay off" function to allow it to remain on for a set period, after the ignition is switched off. See section 2.7 for information regarding using the CAN bus to provide an ignition sense.

4.6.5.1. Provision of ignition sense from an ignition feed

There may be no ignition sense present on the vehicle's original wiring harness plug to which the equipment is connected. When this facility is required the equipment's ignition sense should be connected to a positive feed controlled by the vehicle's ignition switch, where such a suitable feed is available.

Consult with the vehicle manufacturer to determine a suitable source feed for ignition sense.

If the ignition sense facility is not required it still may need to be connected to a permanent positive supply to ensure the equipment functions. Follow equipment manufacturer's instructions and recommendations at all times.

In either event the ignition feed to the equipment must be via an in-line fuse of the correct current rating.

4.6.5.2. Provision of an ignition feed

If equipment is solely powered from a positive feed controlled by the vehicle's ignition switch the feed must be checked to ensure it can supply adequate current for both the equipment being installed and other vehicle or supplementary equipment connected to it.

Consult with the vehicle manufacturer to determine a suitable ignition feed.

The ignition feed to the equipment must be via an in-line fuse of the correct current rating.

4.6.6. Vehicle supply greater than 12 volt

A 12 volt tap must not be taken from the batteries of a vehicle that has a supply greater than 12 volts.

Where a vehicle has a supply greater than 12 volts then it is essential that either the equipment is rated for the higher voltage or a suitable regulator or converter is used that will provide the nominal supply voltage and current for which the equipment is designed.

4.6.6.1. Voltage regulator/converter

Any regulator used must be compliant with requirements in section 2.2. Also, if applicable, see section 4.6.7.1

A means of switching off the regulator or converter must also be provided. This can be via the ignition feed acting as a sense, direct switching from the mobile radio, a master switch or some other means agreed with the customer.

The supply cable to the regulator or converter must be as short as practicable and suitable fuses should be fitted to the input and output leads as close as possible to the supply.

The converter unit must be securely mounted in accordance with the manufacturer's instructions.

Unless the converter unit is suitably environmentally protected it must be located in a dry and well-ventilated position.

4.6.7. Isolated power supply

The installation of the mobile radio equipment should be carried out to maintain the integrity of the vehicle isolated power supply.

4.6.7.1. 24V or higher isolated supply

When a 24 volt, or higher, supply is used on an isolated return vehicle system, a suitable DC converter, providing DC isolation, i.e. no DC continuity between battery and output, must be used. After fitting the converter, it must be verified that isolation has been maintained, see section 4.7.2.1.

4.7. Basic checks of an installation

Once physical installation of equipment has taken place it should be checked. The installation must be safe prior to applying power for further checks.

4.7.1. Equipment power supply checks

The equipment power supply checks should be undertaken prior to power being applied to the newly installed equipment.

The power source should be checked for reversed polarity prior to connection to the installed equipment. Fuses should be verified to ensure that they are the correct rating for the installation.

4.7.2. Isolated supply system checks

Where there is an isolated supply system, it must be ensured that the installed equipment has not degraded the insulation between each terminal of the battery and chassis, i.e. positive to chassis and negative to chassis.

Continuity checks, carried out with a suitable multimeter, between the positive and negative supplies and the vehicle chassis must be carried out before and after installation to ensure isolation of the power supply is maintained.

The checks should be carried out with the isolation switch in the on position.

4.7.2.1. Isolated converter or regulator checks

Where a converter or regulator is used, ensure the fused supply to the converter is capable of being switched off. This can be achieved using the isolating switch or via the ignition switch.

4.8. Testing Antennas

It is important to test the antenna installation when complete to ensure that it is operating effectively. This may also involve tuning the antenna for a mobile radio or specialist installation.

Table 5 - Antenna Test Requirement

Installation type	Continuity check	VSWR test
Cellular GSM/3G Asset Tracking and AVL Simple antenna* with pre-terminated connector	YES	Recommended test An antenna analyser (see section 4.8.1)
Cellular GSM/3G Asset Tracking and AVL Panel mount or other antenna with installer fitted connector.	YES	Recommended test An antenna analyser (see section 4.8.1)
Mobile Radio, PBR & TETRA	YES	It is compulsory to test VSWR. This may involve tuning the antenna to match frequency.

**Simple antenna defined as a one piece unit with integral coaxial cable and pre-fitted connector.*

Ensure the antenna radiating element is of the type and length specified by the manufacturer for the relevant frequency in use. It should be noted that most antennas for cellular GSM/3G radio operation are pre-tuned and not adjustable.

4.8.1. Antenna DC tests

Before connection to the equipment the antenna system should be DC tested at the equipment end of the coaxial cable for continuity and to ensure there is no short circuit.

A DC continuity check is not possible with a fully encapsulated antenna as the protective cover must not be broken in order to undertake the test.

The resistance will depend on the length of the co-axial cable running between the connector and the aerial base. Typically for a motor car it should be less than 0.2 Ohms for the connector body to aerial base, or ground plane, measurement and 0.3 Ohms for the centre-pin to radiating element, where it is possible to take this measurement.

For reference resistance measurements of RG58, the typical 50 Ohm co-axial cable used and supplied as an integral part of aerial bases, indicate a resistance per metre length of approximately 15 milliohms for the cable's screen and 50 milliohms per metre length for the inner conductor.

The tests are as follows:

- Centre conductor continuity check
 - low resistance between the centre pin of the coaxial connector and the antenna radiating element (less than 0.3 ohm)
- Earth continuity check
 - low resistance between the body of the co-axial connector and vehicle earth/ground plane (less than 0.2 ohm). This test is applicable to standard body mounted antennas.
- Short circuit check
 - In the case of a simple panel-mount quarter-wavelength aerial there should be no connection between the centre pin and body of the co-axial connector.

Note that some types of antennas present a DC short across the coaxial cable, for example some glass mount, centre tapped, end-fed half wave etc. In this case and where possible the cable should be disconnected from the antenna and checks for continuity and no short circuit carried out before reconnection to the antenna.

Active GPS antennas can, dependent on make of unit, present a resistance (usually 300 to 400 ohm) between centre conductor and connector body. Check with manufacturer for specification. For 'GPS Mouse' (combined receiver/antenna unit) type only a functional test needs to be carried out, see section 4.8.3.

For an antenna with 'phantom' power feed, do not connect it to the equipment if there appears to be a short circuit fault as this may cause damage to the equipment concerned.

Consult the manufacturer's installation instructions for guidance where applicable.

4.8.2. VSWR measurements and analysis for transmitting antennas

A VSWR test is either recommended or mandatory depending on type of installation (see matrix table in section 4.8). This is due to the variation on measurement and adjustment that can be undertaken for different equipment using different radio frequency bands. For example a GSM mobile phone antenna usually does not provide any scope for measurement or adjustment being already tuned by the antenna manufacturer.

In the case of a more complex installation whereby a tuneable antenna or a multiple antenna system is employed, VSWR must be carried out.

The VSWR measurement should be taken using a calibrated tester suitable for the frequency band and RF technology and power of the radio installation.

A suitable antenna tester may be either:

- a VSWR meter capable of producing a VSWR result at expected RF power level of the installation
- a through-line wattmeter capable of measuring both the forward and reverse RF power levels of the installation and a chart to determine VSWR from the obtained results

For digital radio systems which use a pulsed RF carrier, for example GSM, 3G and TETRA, it may be more beneficial to use an antenna analyser that works independently of the installed transceiver. This device is self contained so does not require the radio equipment to transmit, as would be the case with a more traditional power meter. The analyser connects directly to the antenna under test and generates a low level RF carrier at the required frequency in order to measure the VSWR.

Analysers are suitable for analogue and digital systems whereas the traditional power meter is only suitable for analogue systems.

4.8.2.1. Undertaking VSWR test

With all vehicle doors, bonnet, boot, etc closed check the match of the antenna using the tester.

The VSWR should be 1.5 to 1 or better (i.e. less than 1.5:1) when measured in the mobile transmit (uplink) band.

For an internal window mounting or covert type antenna for cellular GSM/3G this limit may be increased to 2.0:1.

For mobile radio covert antennas the limit may be higher – if necessary consult the antenna manufacturer for guidance.

If the result obtained is outside of these limits then the antenna and its installation should be inspected to find the cause of the high VSWR, rectified and then re-tested to ensure it meets the relevant limit.

Note that when reviewing the results of a VSWR test consideration should be given to the calibration accuracy of the meter and the test location. For example sometimes it is possible to obtain erroneous readings when testing a cellular GSM/3G antenna installation in close proximity to a base station. If the initial reading is not consistent with expectations it may be worth moving the vehicle to a different location and carrying out another test.

The final value obtained should be recorded on the installation report.

4.8.3. Testing GPS antennas

As a GPS antenna is an active receive type it must not be connected to any type of transmitter including an antenna analyser. It is therefore not possible to carry out a VSWR check.

GPS reception requires that the antenna has a clear view of the sky in order to function. This may require the vehicle to be moved out of the workshop but see section 5.3.6 regarding road testing and adequate insurance.

The recommended method of checking the GPS antenna is having completed the DC continuity tests connect it to the GPS receiver and check for satellite acquisition or examine receiver system diagnostics.

Note that it may be necessary to ask the customer to assist with this process as it could require user authorisation to log on to the network or system to obtain the relevant diagnostic information.

As a further measure the installed GPS antenna could be checked for satellite acquisition against a reference magnetic mount GPS antenna placed adjacent to the installed antenna. This is then temporarily connected to the GPS receiver and results compared.

For a GPS Mouse (combined GPS receiver/antenna unit) type a functional check should be carried out. With the GPS Mouse connected to the terminal equipment check for satellite acquisition or examine system diagnostics.

4.9. Power up testing

These tests should only be done when the installation and checks in section 4.7 are complete.

Additional checking of transportable equipment may be necessary due to the internal battery supply that may be fitted. In these cases the power supply lines and fuses should be checked independent of the portable equipment.

4.9.1. Transmitter output power

This section refers particularly to higher power, as per section 2.3.1.1, and PBR equipment installation.

The power output from the transmitter should be measured using an RF wattmeter connected temporarily to the transmitter output coaxial socket. The measured power should be checked with the licence conditions and vehicle manufacturer's stated power limit.

If the imposed limit stipulates ERP this should be calculated from the transmitter output power and the known antenna gain and feeder loss.

For example the radio licence conditions may grant 25W, but the vehicle's manual only stipulates 10W max for a transmitting device. In this case checking against the licence conditions might actually be invalid, therefore the vehicle manufacturer's power limit must take precedence and the installation should not be commissioned if the power limit is exceeded.

4.9.2. Equipment using ignition sense

Where an ignition sense is used, ensure the mobile equipment turns off when the ignition is switched off. This test should be carried out with the in-car entertainment unit switched on and repeated again with the unit switched off.

4.10. Reassemble vehicle

Care should be taken not to damage trim, the vehicle interior and other panels during refitting.

When re-fitting panels and trim, ensure all cables are not trapped or damaged.

Check that cables will not run below panel screw fixing positions where the screw could snag the cable.

Ensure that all items and vehicle fittings removed or disturbed during installation of the equipment function correctly when refitted. This may include items such as the following

- the glove box opening/closing
- sun visors
- storage compartments
- cup holders

See section 2.9.2 if the vehicle battery has been removed during the installation.

4.11. Uninstalling equipment

This section covers the removal of equipment from a vehicle, when no further equipment will be installed in that vehicle. The equipment may be reused in another vehicle or not depending on the circumstances.

4.11.1. Aims of equipment de-install

It is essential that once the equipment is removed, the vehicle is left in a safe and serviceable condition.

Very often, the customer will want the minimum amount of work carried out in order to reduce the cost to de-install the equipment, which may only be disposed of anyway.

The work required should be discussed with the customer at an early stage to determine if the equipment is to be re-used and if so, whether the wiring loom and other fittings are required to be retained.

The installer should always be aware that he has ultimate responsibility to leave the vehicle in a safe condition and any work required to achieve this should be included in the customer discussion and the job contract.

4.11.2. Equipment de-install procedure

If the equipment is to be re-used at a later date or re-fitted as part of a de-install/re-install job then, if practical, a functional test should be carried out to ensure that it is working correctly prior to it being removed. Any problems should be recorded on the installation report for future reference.

An installation report must be completed for the vehicle, pre-checks should be made and any defects, whether with the equipment or the vehicle, noted on the report prior to work being started, refer to installation pre-checks section 3.3 and 3.6.

After the equipment has been removed and work on the vehicle completed, a further functional check of the vehicle systems should be made and noted on the installation report.

The installer should:

- Ensure that any power cables left in the vehicle have the fuses removed and the open ends insulated
- Ensure that any connections made to a CAN bus that were part of the installation have been removed and that the bus wiring is properly insulated to retain its integrity
- Before removing a glass mount antenna, check the screen for any chips or cracks in the immediate and near vicinity of the mounted components
 - Any attempt to remove these parts from a damaged screen could result in a major failure of the glass
- Where a body mount antenna is fitted consider whether, if removed, the remaining hole can be effectively sealed.
 - Unless the vehicle is to be refurbished, it is usually advisable to leave the antenna base on the vehicle.
- Remove any mounting brackets or hardware that if left in the vehicle could cause injury to the vehicle users or create a hazard to any load being carried
- Determine correct disposal of any unwanted equipment, see section 2.3.2

- Units may contain a data log stored on in-built hardware or on removable flash memory – the customer should be consulted to determine a satisfactory disposal policy
- Any radio equipment to be disposed of should have any frequency or other user specific parameters erased before disposal
 - In the case of GSM or 3G equipment, this would usually involve removal of the SIM card and erasing memories and call data information
 - Some equipment has a factory reset option that reverts the item back to a 'factory shipped' condition by erasing all memories and settings.

Any equipment or components to be scrapped should be disposed of in accordance with the WEEE Directive, see section 2.3.2 for further information.



5. Test and final Inspection

Before the vehicle is handed back to the customer the installation should be verified.

5.1. Vehicle and site check

A visual check must be made to ensure that tools, items excess to requirement, waste and other debris not required by the customer are cleared from both the vehicle and the site and subsequently disposed of in the correct manner, see section 2.3.2 regarding WEEE obligations.

5.2. Installation Checks

For vehicle inspection it is recommended a check list system is used to ensure a consistent standard. It also must be taken into consideration that several checks, which are not necessarily on the checklist, such as door, boot, bonnet and seat belt operation should be performed at this time.

Check that the installation is in accordance with the customer's requirements and complies with all the recommendations given in FCS1362:2010.

The make, model, serial, mobile user number of the equipment and the type of antenna should be recorded.

The antenna VSWR should also be recorded and where appropriate the output power from the mobile transmitter.

All functions of the equipment should be checked, see section 5.3.

A separate test report on the functions may be needed for the different types of equipment i.e. PBR, cellular GSM/3G, TETRA.

The installer should sign the post-installation report to confirm that the work has been carried out and the installation tested. The vehicle may be released as per section 6 and the customer should then sign to state that the work has been carried out to their satisfaction.

The post-installation form may include the following statement:

"This equipment has been installed in accordance with the customer's instructions and complies with UK Code of Practice FCS1362:2010 unless detailed below."

The pre- and post-installation report may be combined on one form. Examples of such forms can be found in Appendix D.

5.3. Final Tests

Once the installation has been checked, the vehicle can be tested to ensure nothing untoward has occurred due to the work undertaken.

5.3.1. Static tests of vehicle and equipment functions

After the installation has been completed tests of both vehicle and equipment functions must be carried out.

These tests must be done to ensure that there are no interactions between different items of installed equipment and that no item of equipment interferes with any of the vehicle's electrical or mechanical functions.

The results of all tests should be recorded.

5.3.2. Checks to be undertaken during final testing of installation

Checks should be made for interference to and from electrical and electronic equipment in the vehicle when the radio equipment is in standby, receive and transmit modes.

Test calls should be made in both transmit and receive modes to check all functions of the mobile radio equipment wherever possible.

It is particularly important to check for the correct operation of vehicle electronic systems while operating installed transceiver units. EMC problems might be indicated either by warning lights on the vehicle's instrument cluster or by changes in direction indicator speed or engine RPM, both indicated and actual. Although this applies especially to high-powered radio equipment the effects of cellular GSM, 3G and TETRA transceivers must also be included.

Include the vehicle's ICE system in the testing. If the installation has included fitting an audio mute system ensure that any of the vehicle's warning tones presented through the vehicle's ICE are still functioning when the radio equipment is in use. Inform the customer if this is not the case and take expert advice if this problem needs to be resolved.

5.3.3. Checks on emergency service vehicles

The National Association of Police Fleet Managers (NAPFM) Design Guide for Vehicle Installations should be consulted whenever tests are carried out on emergency service vehicles.

Prior to starting such work, a copy of this document should be obtained from the National Policing Improvements Agency (NPIA) Automotive and Equipment Section (AES) – see Appendix C.

5.3.4. Vehicle's engine and ignition during testing

All tests should be carried out for the correct operation of all installed equipment with the engine running at fast idle (approximately 1500 RPM) and with the vehicle stationary.

Suitable exhaust extraction must be used if the tests with the engine running are carried out inside a building.

See section 5.3.6 for information on undertaking road testing.

5.3.5. Dealing with problems found in final testing

If the installed system causes interference to the normal operation of the vehicle the system shall be deactivated until the system manufacturer advises suitable corrective action.

Although aftermarket equipment may have been tested against the relevant EMC specifications prior to coming to the market it may still generate narrow and broadband emissions of sufficient amplitude to cause interference to radio reception.

With analogue voice radios this interference may be heard as distortion, noise or whistling superimposed on the incoming signal.

For digital voice or data services the effects of the interference are more difficult to ascertain and may result in intermittent denial of service depending whether the vehicle is located within a good or poor service coverage area.

Interference may be visible on the signal strength (RSSI) indicator on some radio terminals whilst the service is being blocked. Such interference may be perceived as a loss in service or coverage by the customer.

If any interference occurs then every effort should be made to locate and rectify any installation problem that may be the cause. Section 4.2.1 may be beneficial in this respect.

If a problem is found and cannot be rectified, and it is suspected that the equipment or vehicle is out of specification, then the appropriate manufacturer, agent or supplier should be consulted.

If after following the advice of the manufacturer, agent or supplier the problem with the vehicle still exists, it should be noted and the customer must be advised.

Under no circumstances should an attempt be made to modify any device or system that is being affected by EMI.

5.3.6. Road testing

Provided that the static post-installation tests have shown both equipment and vehicle to be operating correctly then on-road testing of communications and other installed equipment is generally considered

unnecessary. Post installation road testing should, however, always be considered to ensure that there are no adverse EMC effects between the installed equipment and the vehicle systems.

The decision to road test is influenced by the following parameters:

- the type, complexity and end use of the vehicle
- knowledge and experience of the installer
- vehicle manufacturer's recommendations
- the type of installed equipment
- equipment manufacturer recommendations
- frequency band
- RF power
- antenna type and location
- customer requirements

5.3.6.1. Requirements for undertaking a road test safely

Should on-road testing be required it must

- Only be carried out with the vehicle owner's permission
- Only be undertaken if a suitably qualified and insured driver is available

Safety dictates that road testing should be a two-person operation where applicable. Ideally the person carrying out the tests should not drive the vehicle at the same time.

Wherever possible the usual driver of the vehicle should take part in the road test. This will provide an additional degree of quality assurance in that the driver is familiar with the vehicle and can better check if there is any degradation of vehicle performance.

5.3.7. Recording findings of a road test

The results of all road testing should be recorded.

Where on-road testing has not been carried out, and in particular where it has been recommended to the customer, a statement to that effect should be included in the installation report and signed off by the customer.

6. Demonstration and Customer Training

Correct operation of the equipment and all the facilities of the installation should be demonstrated to the customer, user or nominated representative and relevant documentation handed over.

6.1. General

In the case of a PBR installation the customer may be instructed on the correct procedures to be used over the air, i.e. use of call signs, messages to be kept brief and to the point and, where appropriate, to monitor the channel before passing a message.

6.2. Safety instructions

The user should be made aware of the provisions of the Highway Code and in particular the legal requirements of Road Traffic Construction and Use Regulation 110 that prohibits the use of mobile phones and other hand-held microphones by a driver while driving except in the case of a 'two-way radio', which is defined more precisely in Regulation 110.

The customer should be instructed to operate the equipment with caution until satisfied with its operation in the vehicle and that there are no issues with the installation.

The end user should be encouraged to only use the equipment when it is safe to do so.

Where antennas, especially those connected to high power equipment, have been fitted to a vehicle the customer and end users should be informed not to touch the antenna when the equipment is switched on.

6.3. Handing over

Along with the vehicle and keys all documents associated with the installation and conformity of the equipment should be handed over to the customer together with any special instructions to do with the installation. The customer should sign to state that the installation is satisfactory.



7. Acknowledgments

Many representatives from all areas of the radio communications industry, vehicle manufacturers and government bodies have been instrumental in pooling their knowledge in order to update this document. The Federation of Communication Services wishes to acknowledge the valuable work undertaken by all those involved the production and revision of this Code of Practice.

Signed

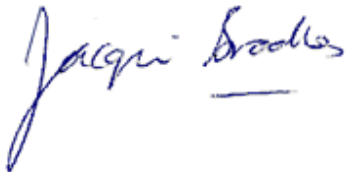

Position: CHIEF EXECUTIVE OFFICER
Federation of Communication Services

Review Chairman

Tim Cull, Telecom Policy Services Ltd

Contributors

Airwave Solutions Ltd	Motorola Ltd
Alexander Dennis Ltd	Nationwide Service Care Ltd
Arqiva	Network Rail
Avian Mobile Limited	National Policing Improvement Agency (NPIA)
AWE	Oakmead Consulting Ltd
Chameleon Codewing Ltd	Ofcom
Comptons	Orange - Israel
Confederation of Passenger Transport	Panorama Antennas Ltd
David Partridge - Consultant	Premier Communication Electronics Ltd
Diareyes	Radio Consultants
Everything Everywhere Limited	Radio Telecom Services Ltd
Executive Installations Ltd	Rail Safety & Standards Board (RSSB)
GB Electronics (UK) Ltd	Signature Industries Ltd
ITS United Kingdom	Society of Motor Manufacturers and Traders (SMMT)
Joint Radio Company Ltd	Stream Communications Ltd
Microbus Ltd	SunGard Public Sector
MIRA Ltd	Telefonica O2 UK Ltd
Mix Telematics UK Ltd	VIDG Ltd
Mobile Data Association (MDA)	

Appendix A: Installation Process Flow Chart

Installer Equipment Vehicle

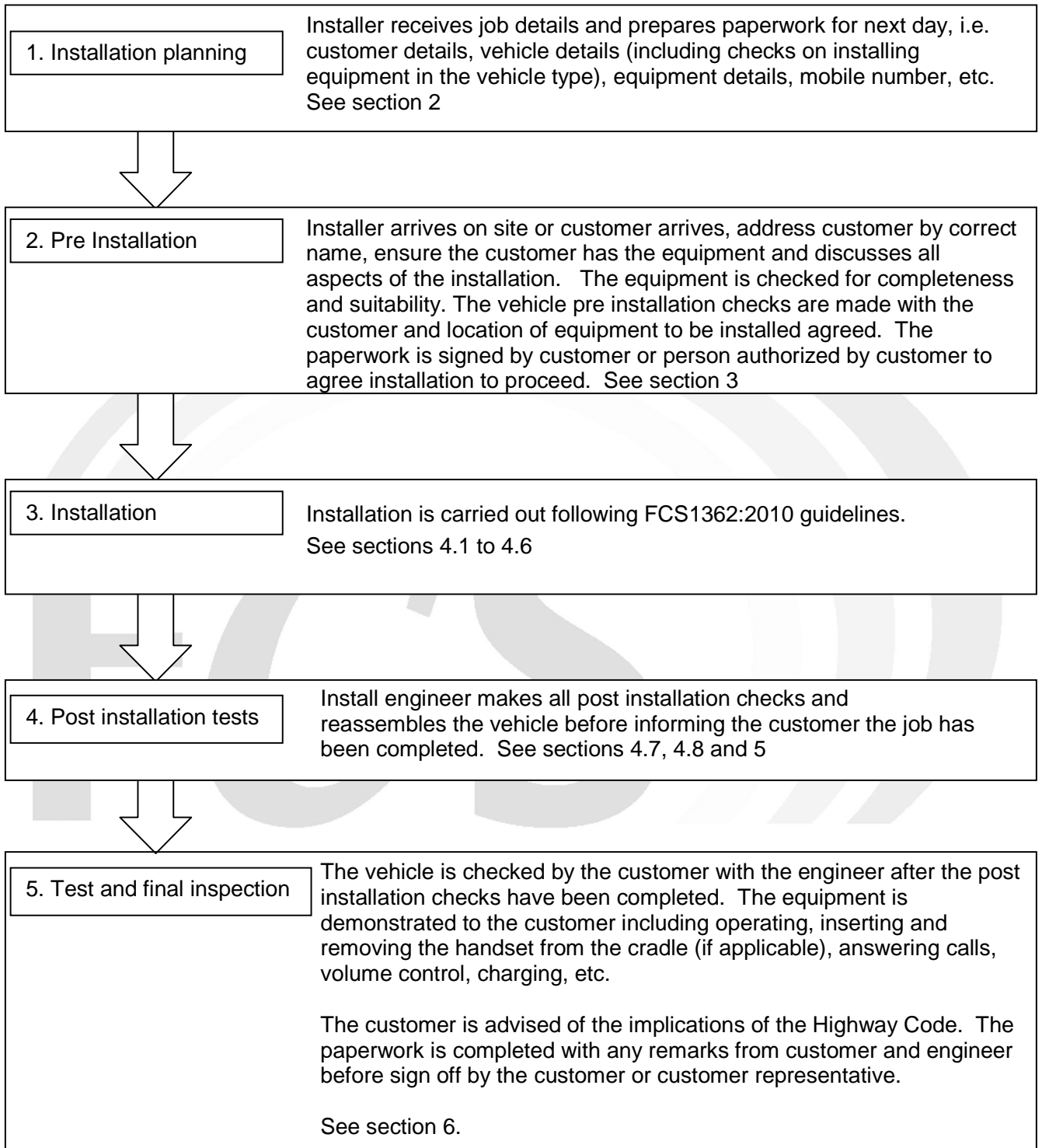

Appendix B: Further information and documentation

The following reference documents are listed for consultation in respect of installing equipment into vehicles. The FCS webpage (link below) contains an updated list of links to information regarding these documents. <http://www.fcs.org.uk/MemberGroups/Installers/FCS1362Links.aspx>

Document	Notes
Automotive EMC Directive 2004/104/EC (as amended by 2005/2009/19/EC and 2005/83/EC) and UNECE 10.03	Covers type approval of vehicles and of electrical equipment: electrical and electronic sub assemblies (ESAs) for fitment to vehicles.
74/60/EC and UNECE 21	Directive for interior fittings within a vehicle
BS EN 1789:20007	A standard that applies to ambulances and vehicles adapted or modified to carry a stretcher.
COSHH http://www.hse.gov.uk/coshh/	Control of substances hazardous to health
Council Recommendation 1999/519/EC	Regarding the limitation of exposure of the general public to electromagnetic fields (0 Hz to 300 GHz).
Data Protection Act 1988	Controlled by the Information Commissioner's Office legislation concerning the control of stored personal data
Directive 97/24/EC Chapter 8	Covers the EMC of motorcycles and their parts and equipment.
Environmental Protection Act 1990 (Section 34: Duty of Care) The Waste Electrical and Electronic Equipment (WEEE) 2002/96/EC Directive 2006/66/EC Battery Directive	Covers the disposal of Waste Electrical and Electronic Equipment (WEEE) and Batteries
Generic Electromagnetic Compatibility (EMC) Directive 2004/108/EC	This directive supersedes 89/336/EEC and covers the agreed levels of EMC, disturbance and immunity for all electrical/electronic appliances and components manufactured for the European market.
Health and Safety at Work etc Act 1974 and subsequent amendments	Provides a wealth of information for securing the health and safety of persons at work. For further information visit the Health and Safety web site http://www.hse.gov.uk
Highway Code	Essential reading for all road users and pedestrians,
ISO 4513	ISO 4513 specifies a method for establishing a model for the purpose of measuring a driver's field of view.
ISO 9000	A standard intended to help organizations achieve high and consistent levels of quality.
ISBN 9780852933916	'Recommendations for Radio Communications Equipment and its Installation in Petroleum Road Tankers'. A document published by the Energy Institute and available from Portland Press. (See Appendix C).
Road Vehicle (Construction and Use) Regulations 1986 (as amended).	These regulate the modifications which can be made to a vehicle in service.

RTTE Directive 1999/5/EC	Ensures that telecommunications products meet essential requirements in terms of health and safety, electromagnetic interference and use of the radio spectrum.
Wireless Telegraphy Act	Covers the licensing of radio communications equipment. Further information can be found on the Ofcom web site www.ofcom.org.uk
Work at Height Regulations 2005	The UK implementation of EU Directive 2001/45/EC applies to all work at height where there is a risk of a fall liable to cause personal injury.
Additional codes of practice and link to sources	Documents that may be applicable to a specific task, for example 'the DCLG Code of Practice for Fire Service Vehicles' or the National Association of Police Fleet Managers "Police Vehicles Installation Code of Practice" can be obtained from the sources listed in Appendix C.



Appendix C: Contact information

Further information relating to installation of mobile radio equipment may be available from the following. The FCS webpage at <http://www.fcs.org.uk/MemberGroups/Installers/FCS1362Links.aspx> contains an updated list of links to information regarding these organisations and government departments.

Department for Business, Innovations & Skills (BIS)

(was Department for Business, Enterprise and Regulatory Reform - BERR, formally the Department of Trade and Industry - DTI)

<http://www.bis.gov.uk/>

WEEE Directive information:

<http://www.bis.gov.uk/weee>

Department for Communities and Local Government (DCLG)

<http://www.communities.gov.uk/corporate/>

Department for Transport (DfT)

Transport Technology and Standards 63, Zone 2/064

Great Minster House

76 Marsham Street, London

SW1P 4DR

Tel: 020 7944 2078 - Vehicle Standards & Engineering Division (VSE)

<http://www.dft.gov.uk/contact>

Contact for general advice on the automotive EMC Directive e.g. whether or not e-marking is required for certain components.

The Environment Agency

General Enquiries: Telephone 08708 506 506 (Mon-Fri 8-6)

<http://www.environment-agency.gov.uk/>

WEEE Directive information:

<http://www.environment-agency.gov.uk/business/regulation/31975.aspx>

Batteries Directive Information:

<http://www.environment-agency.gov.uk/business/regulation/101529.aspx>

Energy Institute

61, New Cavendish Street,

London, W1M 8AR

Tel: 020 8467 7100

<http://www.energyinst.org/>

Contact regarding the document mentioned in section 2.2.4

Also see Portland Press details below.

European legislation

The EUR-Lex Internet web site provides direct, free access to European Law and includes access to inter-alia treaties, legislation, case law and legislative proposals.

<http://eur-lex.europa.eu/en/index.htm>

Federation of Communication Services (FCS)

Representing the Communications Services Industry

Provident House

Burrell Row

Beckenham, Kent

BR3 1AT

Tel: 020 8249 6363

Fax: 0844 870 5927

e-mail: fcs@fcs.org.uk

<http://www.fcs.org.uk/>

Firelink

Part of the Department for Communities and Local Government (DCLG), Fire & Resilience programme.

<http://www.communities.gov.uk/fire/resilience/>

Information Commissioner's Office

Wycliffe House
Water Lane
Wilmslow
Cheshire SK9 5AF
Tel: 0303 123 1113
Fax: 01625 524510

MIRA Ltd

Watling Street
Nuneaton, Warwickshire
CV10 0TU
Tel: 02476 35549522
Fax: 01203 35032202476358422
<http://www.mira.co.uk/>

**National Policing Improvement Agency
(NPIA)**

Head of Automotive & Equipment Section,
Information, Communications, Technology, &
Science Directorate,
8th Floor West,
New King's Beam House,
22 Upper Ground,
LONDON SE1 9QY.

<http://www.npia.police.uk/>

Refer to the above for copies of the NAPFM
code of practice, see section 2, and information
on the SVA, section 2.7.1

Portland Press

Portland Customer Services
Commerce Way
Whitehall Industrial Estate
Colchester
Essex,
CO2 8HP
Tel: 01206 796351
Fax: 01206 799331
E-mail: sales@portland-services.com
Energy Institute publications may also be
ordered online at:
<http://www.portlandpress.com/pcs/books/default.htm>

Radio Society of Great Britain (RSGB)

3 Abbey Court,
Priory Business Park,
Bedford,
MK44 3WH
Tel: 0870 904 7373
Fax: 0870 904 7374
<http://www.rsgb.org.uk>

**UNECE United Nations Economic
Commission for Europe**

Palais des Nations
CH – 1211 Geneva 10
Switzerland
Phone: +41 (0) 22 917 44 44
Fax: +41 (0) 22 917 05 05
e-mail: info.ece@unece.org

Vehicle Certification Agency (VCA)

1 The Eastgate Office Centre,
Eastgate Road,
BRISTOL,
BS5 6XX
Tel: 0117 9515151
<http://www.vca.gov.uk/>
VCA for the issuing of type approvals and
specific questions on how to obtain EMC e-
marking/type approval, including test
requirements)

Appendix D: Example installation report forms and check lists

Sample form 1

Installation report

Sales order number	Job number	Installation date	Time/date	Engineer	Job Type
--------------------	------------	-------------------	-----------	----------	----------

Installation address	Equipment details		Equipment supplied			
	Mobile no.		Kit	<input type="checkbox"/>	Audio lead	<input type="checkbox"/>
	SIM number		No holes bracket	<input type="checkbox"/>	Antenna	
	EMEI		24V converter	<input type="checkbox"/>	Isolated	<input type="checkbox"/>
	Model type		Other		Glass mount	<input type="checkbox"/>
Lock no.				Body Mount	<input type="checkbox"/>	
Special instructions				Tax disc	<input type="checkbox"/>	
				Strip	<input type="checkbox"/>	

Vehicle details					
Vehicle A			Vehicle B		
Make		Model		Make	
Reg No:		Mileage		Reg No:	
				Mileage	

Vehicle condition											
	Pre	Post		Pre	Post		Pre	Post		Pre	Post
1 Lights side front	<input type="checkbox"/>	<input type="checkbox"/>	12 Wipers front	<input type="checkbox"/>	<input type="checkbox"/>	23 Audio system	<input type="checkbox"/>	<input type="checkbox"/>	34 Security alarm	<input type="checkbox"/>	<input type="checkbox"/>
2 Lights tail rear	<input type="checkbox"/>	<input type="checkbox"/>	13 Wipers rear	<input type="checkbox"/>	<input type="checkbox"/>	24 Audio system code	<input type="checkbox"/>	<input type="checkbox"/>	35 Heated front screen	<input type="checkbox"/>	<input type="checkbox"/>
3 Headlights dip	<input type="checkbox"/>	<input type="checkbox"/>	14 Screenwash front	<input type="checkbox"/>	<input type="checkbox"/>	25 Electric radio aerial	<input type="checkbox"/>	<input type="checkbox"/>	36 Headlamp wash/wipe	<input type="checkbox"/>	<input type="checkbox"/>
4 Headlamps main	<input type="checkbox"/>	<input type="checkbox"/>	15 Screenwash rear	<input type="checkbox"/>	<input type="checkbox"/>	26 Clock (reset)	<input type="checkbox"/>	<input type="checkbox"/>	37 Air conditioning	<input type="checkbox"/>	<input type="checkbox"/>
5 Stop lights	<input type="checkbox"/>	<input type="checkbox"/>	16 Heated rear window	<input type="checkbox"/>	<input type="checkbox"/>	27 Dashboard lighting	<input type="checkbox"/>	<input type="checkbox"/>	38 Engine management	<input type="checkbox"/>	<input type="checkbox"/>
6 Aux lights front	<input type="checkbox"/>	<input type="checkbox"/>	17 Electric windows front	<input type="checkbox"/>	<input type="checkbox"/>	28 Dash warning light	<input type="checkbox"/>	<input type="checkbox"/>	39 ABS	<input type="checkbox"/>	<input type="checkbox"/>
7 Fog lights rear	<input type="checkbox"/>	<input type="checkbox"/>	18 Electric windows rear	<input type="checkbox"/>	<input type="checkbox"/>	29 Indicator warning light	<input type="checkbox"/>	<input type="checkbox"/>	40 Instruments & displays	<input type="checkbox"/>	<input type="checkbox"/>
8 Reversing lights	<input type="checkbox"/>	<input type="checkbox"/>	19 Electric mirrors	<input type="checkbox"/>	<input type="checkbox"/>	30 Main beam indicator	<input type="checkbox"/>	<input type="checkbox"/>	41 Seat belt operation	<input type="checkbox"/>	<input type="checkbox"/>
9 Indicators RH	<input type="checkbox"/>	<input type="checkbox"/>	20 Sunroof	<input type="checkbox"/>	<input type="checkbox"/>	31 Trip computer reset	<input type="checkbox"/>	<input type="checkbox"/>	42 Exterior bodywork	<input type="checkbox"/>	<input type="checkbox"/>
10 Indicators LH	<input type="checkbox"/>	<input type="checkbox"/>	21 Electric seats	<input type="checkbox"/>	<input type="checkbox"/>	32 Interior lighting	<input type="checkbox"/>	<input type="checkbox"/>	43 Interior trim & fixings	<input type="checkbox"/>	<input type="checkbox"/>
11 Hazard warning	<input type="checkbox"/>	<input type="checkbox"/>	22 Central locking	<input type="checkbox"/>	<input type="checkbox"/>	33 Bootload space light	<input type="checkbox"/>	<input type="checkbox"/>	44 Roof lining	<input type="checkbox"/>	<input type="checkbox"/>

Location of					
Antenna		Type		Speaker	
TCVR/Booster				Handset secondary	
Handset				Volt Dropper	
Loom				H/F mic	
Ignition sense	Yes <input type="checkbox"/>	No <input type="checkbox"/>		Muted	Yes <input type="checkbox"/>
					No <input type="checkbox"/>

Tests					
Equipment live	Yes <input type="checkbox"/>	No <input type="checkbox"/>	VSWR	DC	Function, lock

I have read and agree with the above details and give permission for the installation to proceed.
I confirm that where applicable I hold a license to operate the equipment listed above.

Print Name		Signed	
Company name		Date	

Engineer/Customer comments:	Equipment supplied by engineer			
	Kit	<input type="checkbox"/>	Audio lead	<input type="checkbox"/>
	No holes bracket	<input type="checkbox"/>		
	24V converter	<input type="checkbox"/>	Isolated	<input type="checkbox"/>
	Antenna			
	Glass mount	<input type="checkbox"/>	Tax disc	<input type="checkbox"/>
	Body Mount	<input type="checkbox"/>	Strip	<input type="checkbox"/>
Kit to be replaced				

The installation has been carried out in accordance with the customer's instructions and complies with the UK code of practice FCS1362 unless indicated below
Details:

Engineer Name		Engineer Signature	
Customer name (print)		Customer's signature	

Sample form 2

Mobile Installation Check List – Page 1 of 2

Job Number: Date start: Sheet of

Installation location: Customer & Ref. No:

Vehicle Type and Model:

Reg. Number: VIN Number:

Instruction / Type of equipment:

Table 1. Mark the table: N (Not applicable), ✓(Pass - OK), X (Fail). Column A = Pre-fit, B = Post fit, E: EMC tests. See below

Checked Item	A	B	E 1	E 2	Checked Item	A	B	E 1	E 2	Checked Item	A	B	E 1	E 2
Side Lights					Clock					Electric windows				
Headlights dip/main					Dashboard lights					Electrical aerial				
Spot/fog lights					Dash warning lights					External bodywork				
Stop lights					Entertainment unit					Head lining				
Reversing lights					Wipers front/rear					Internal trim & seats				
Boot/tailgate lights					Screen wash					Engine Speed				
Indicators left/right					Headlamp wash/wipe					Rev' & speed meters				
Courtesy lights					Horn					Blue Lights & Siren				
Hazard indicators					Central lock & alarm									

Notes:

Engineer's Signature: Customer's Signature..... (For vehicle arrival)

Table 2. Complete the following table, listing all equipment installed or removed. Also describe the installed equipment location.

Equipment	Manufacturer – Model number – Serial number – E-Compliance number – RF Output power (Watts)	
Transceiver 1	RF O/P:	
	Location:	
Transceiver 2	RF O/P:	
	Location:	
Control Unit(s)		
	Location:	
Aerial & Base 1	Type & Location	VSWR 1:
Aerial & Base 2	Type & Location	VSWR 1:
Aerial & Base 3	Type & Location	VSWR 1:
Loudspeaker	Type & Location	
	Location:	
	Location:	

Mobile Installation Check List – Page 2 of 2

Record and report any effects noticed during the following post-installation tests:

EMC Test 1. (Radiated Immunity) With the engine at 1500 RPM, transmit on low, middle and high frequencies of the used band, operate and observe both the operational equipment (E.G. The light bar and headlight flashers if fitted) and the unshaded items in column “E1” of table 1. Pay particular attention to the engine speed, the rev. counter and the ABS warning indicator.

EMC Test 2. (Radiated Emissions) Note any significant radio interference caused by either operational equipment or “continuous use” vehicle systems (e.g. engine, heater motor or wipers). Record results in the unshaded boxes of column E2 of table 1.

The installer cannot be held responsible for changes to the installation after hand-over to the user. This vehicle has been installed and checked under the guidance of FCS1362:2010.

Owner's Name (Print): Signature: Date:

Engineer's Name (Print): Signature: Date:

Appendix E: Antenna radiation patterns

Typical H plane radiation patterns for various antenna positions on a typical saloon car are shown in the following figures. These illustrate the typical trade off between good omni-directional performance and location of the antenna.

For all the diagrams:

- Plot A on the left is typical for a low band PBR (66-88MHz) wavelength whip.
- Plot B on the right illustrates a typical 900 MHz band cellular GSM/3G mobile phone antenna with gain.

See sections 2.8 and 4.2 for guidance on mounting the antenna on the vehicle.



Antenna mounted on centre of roof

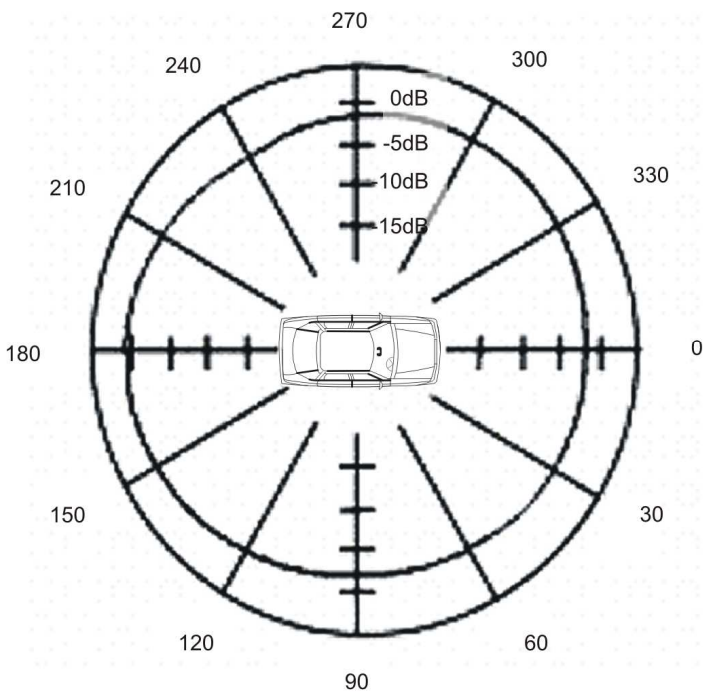
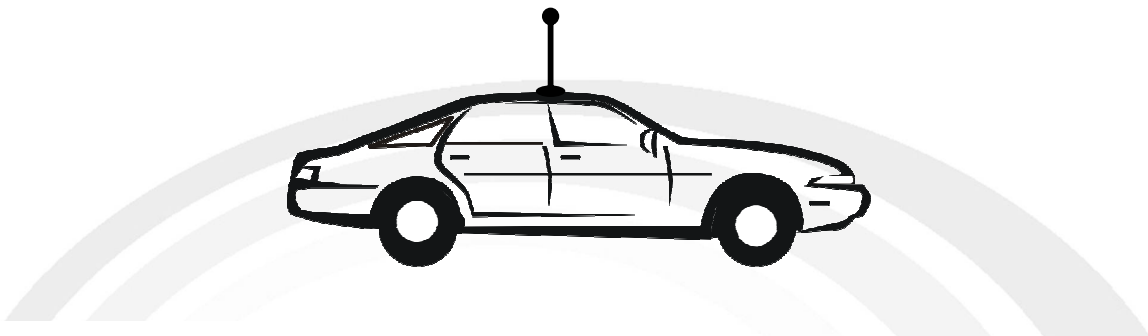
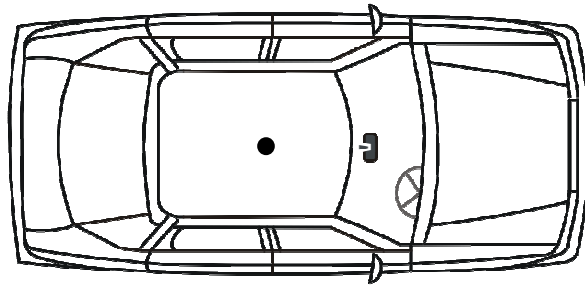

Plot A

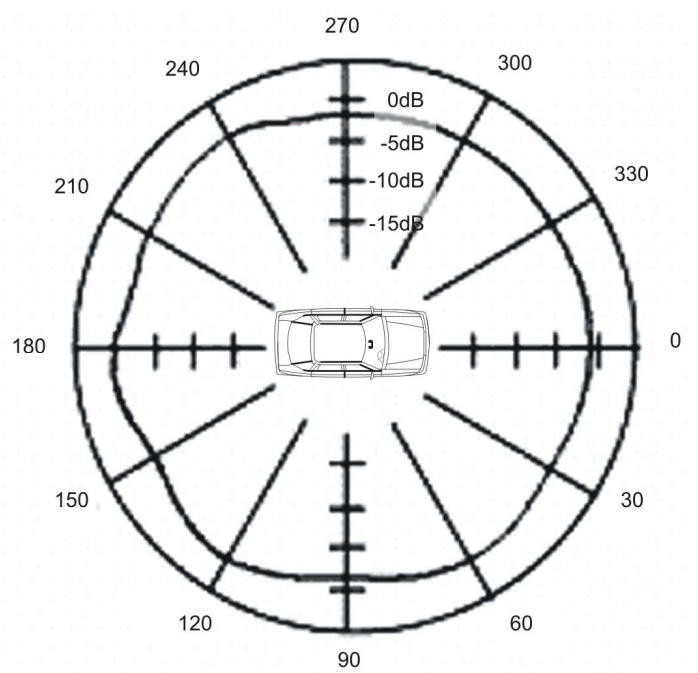

Plot B

Antenna mounted towards rear of vehicle roof, saloon type vehicle

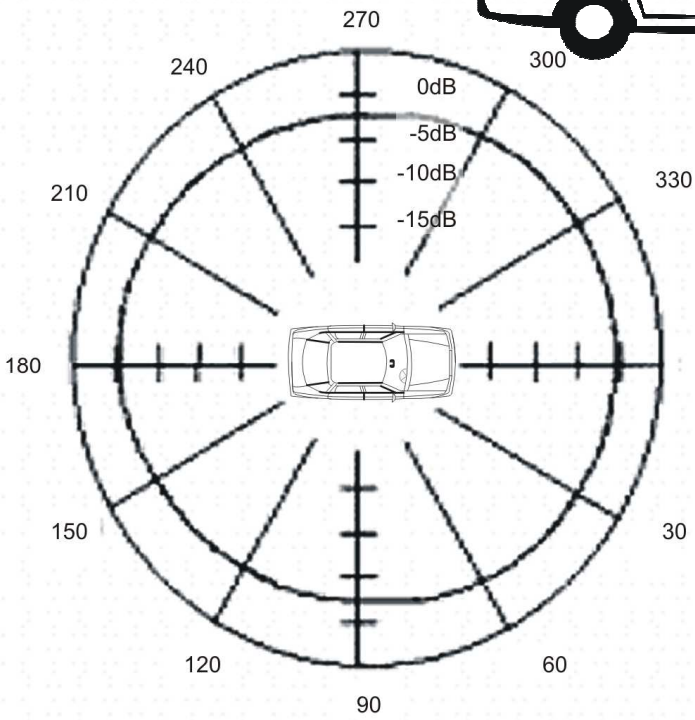
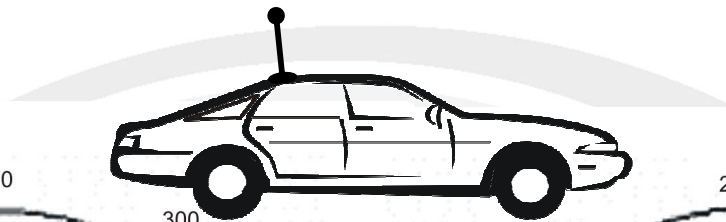
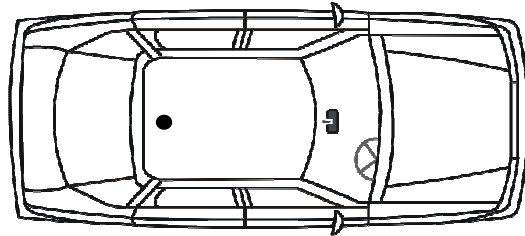

Plot A

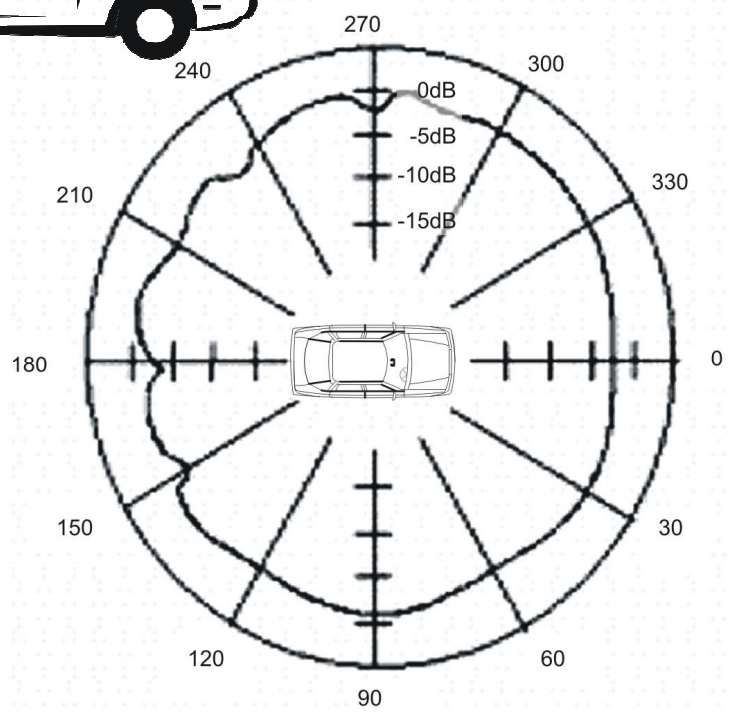

Plot B

Antenna mounted towards rear of vehicle, estate/van type vehicle

Figure below shows a typical radiation pattern of the cellular GSM/3G 900Mhz antenna for a vehicle where the rear slopes away sharply, e.g. a 'hatch-back', estate or van. Compare the plot for the saloon type vehicle on the previous page.

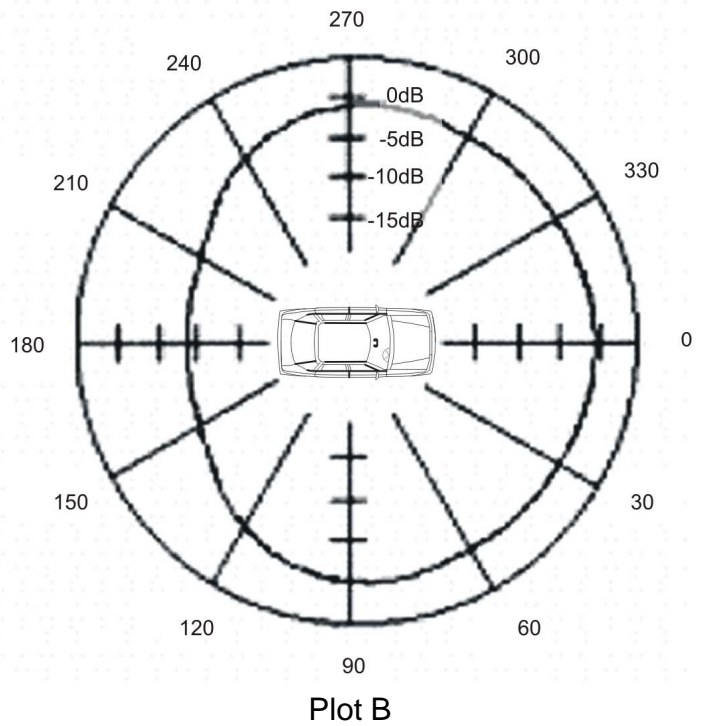
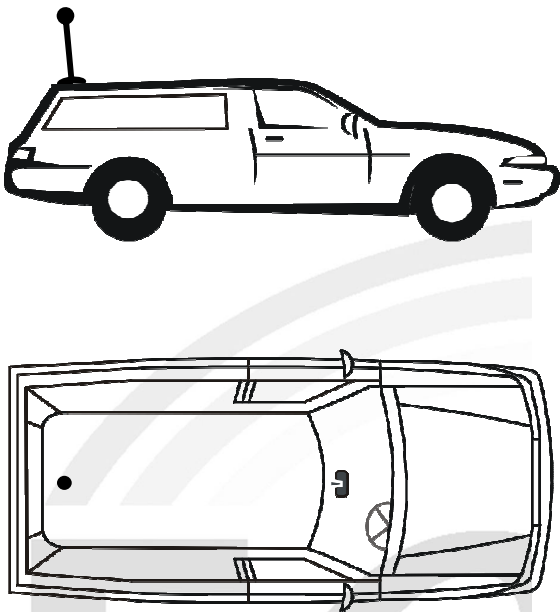

Antenna mounted on rear off side wing

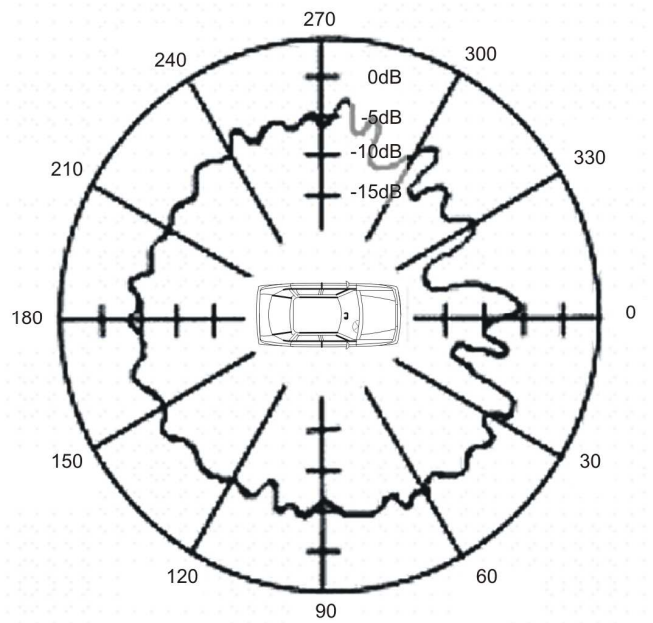
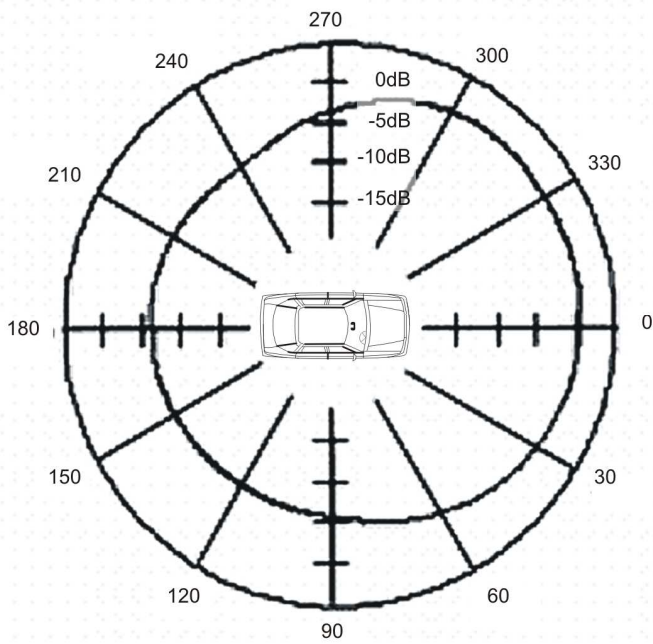
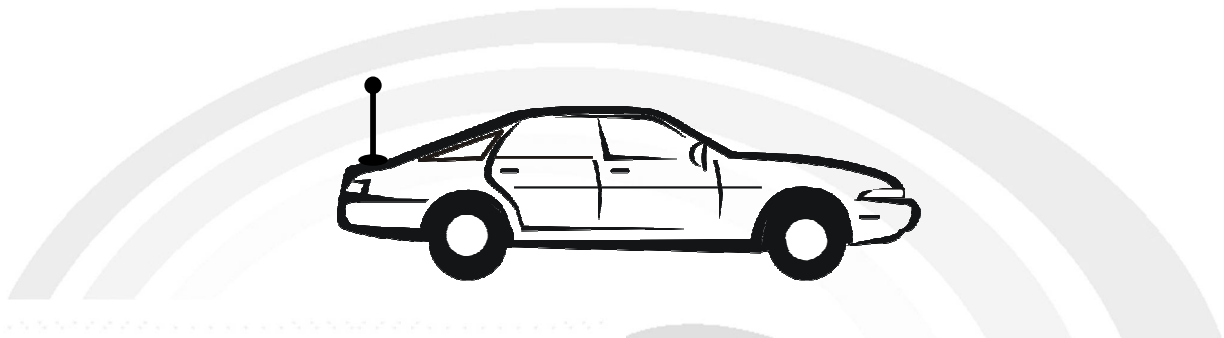
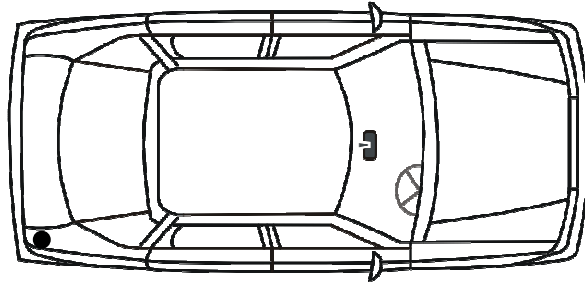

GPS receiving antenna

The following diagram shows the E plane plot for a GPS antenna. This shows the requirement to provide coverage above the antenna location to capture signals from satellites in the sky.

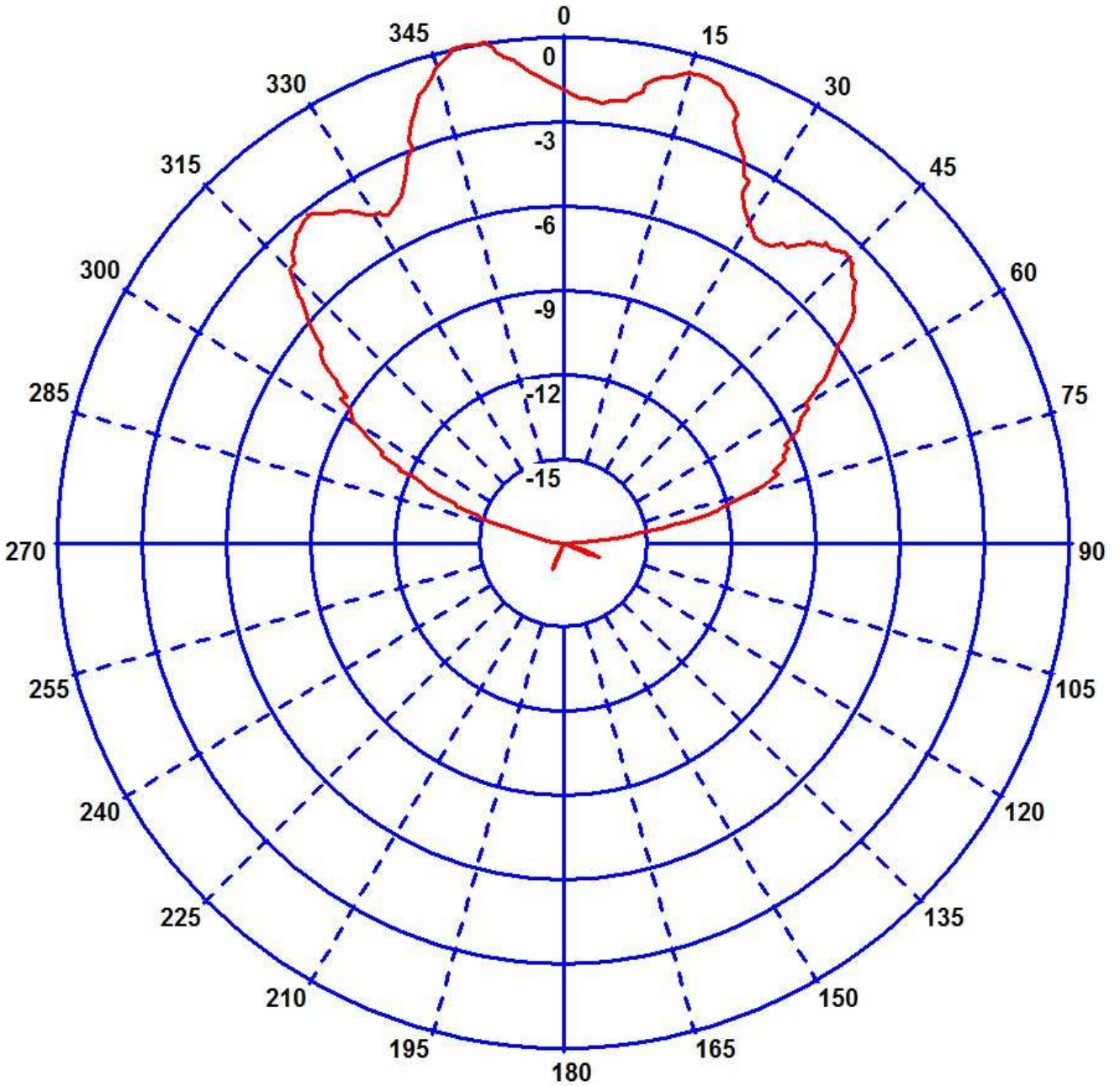

TETRA ¼ wave whip antenna

This is E plane pattern of a TETRA ¼ wave whip and shows null at top and wide aperture, high angle of radiation.

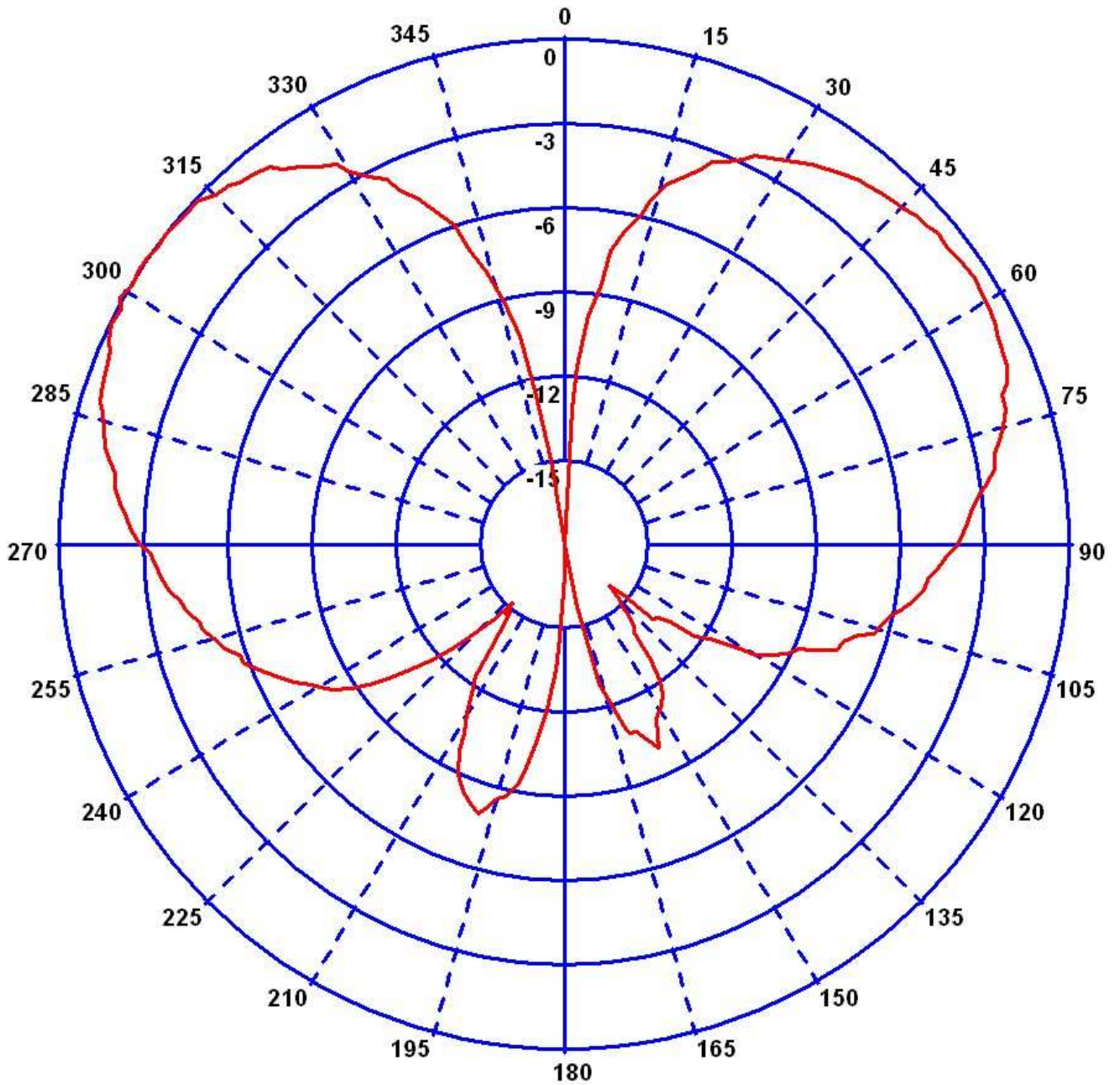

TETRA co-linear whip

This is E plane pattern of a TETRA co-linear whip and shows null at top and lowered angle of radiation to push more signal towards the horizon

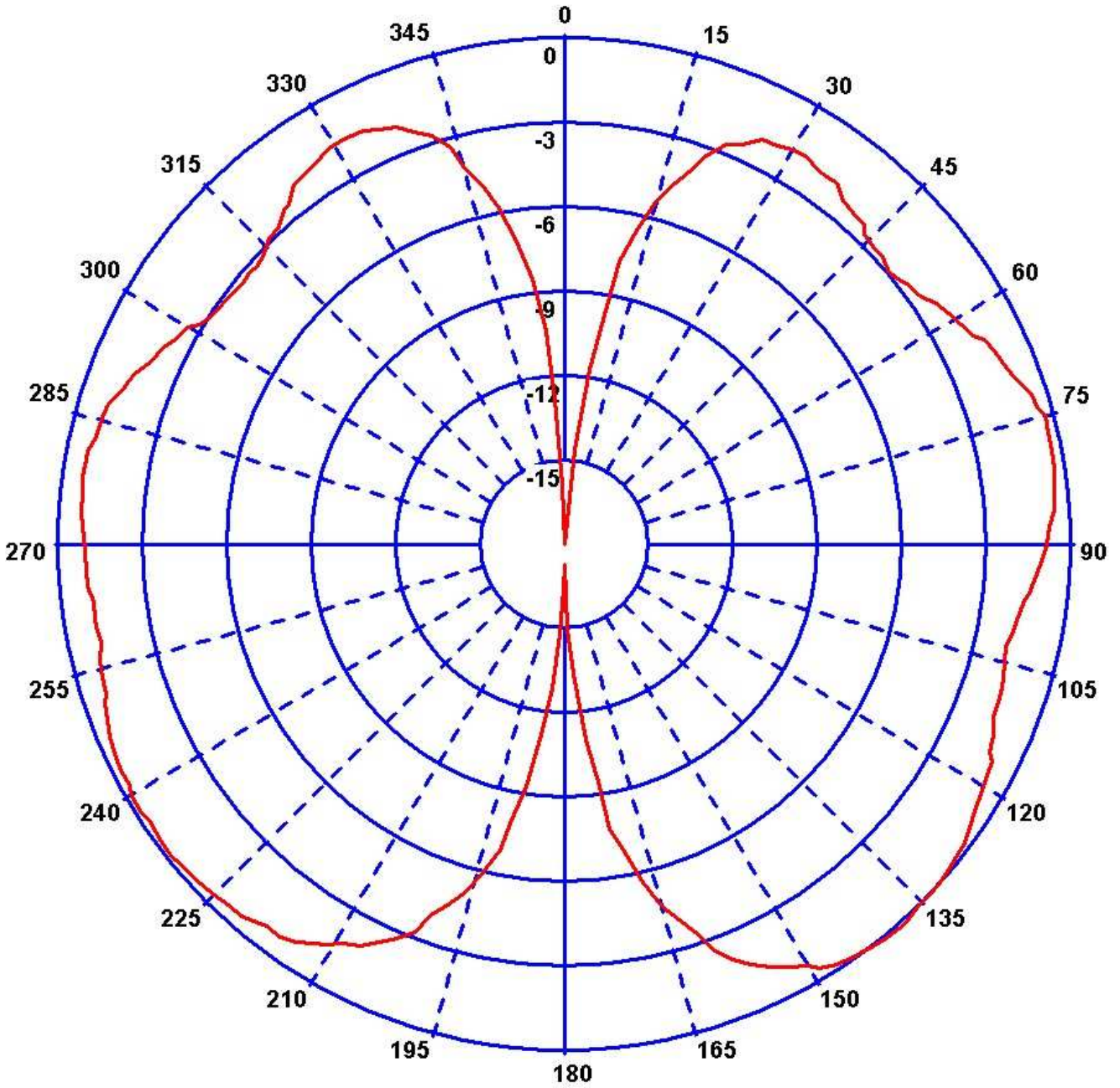

Appendix F: Multiple antenna installation

Image and data supplied by NPIA

The diagram below illustrates an installation with multiple antennas. Although the example is of a typical hatchback police vehicle the principle applies to any vehicle with additional antennas and items installed on the roof.

The antenna positions shown on vehicle roof below have been selected to achieve an effective ground plane and best separation between the antennas and roof clutter.

Diagram and information supplied courtesy of the National Policing Improvement Agency (NPIA).

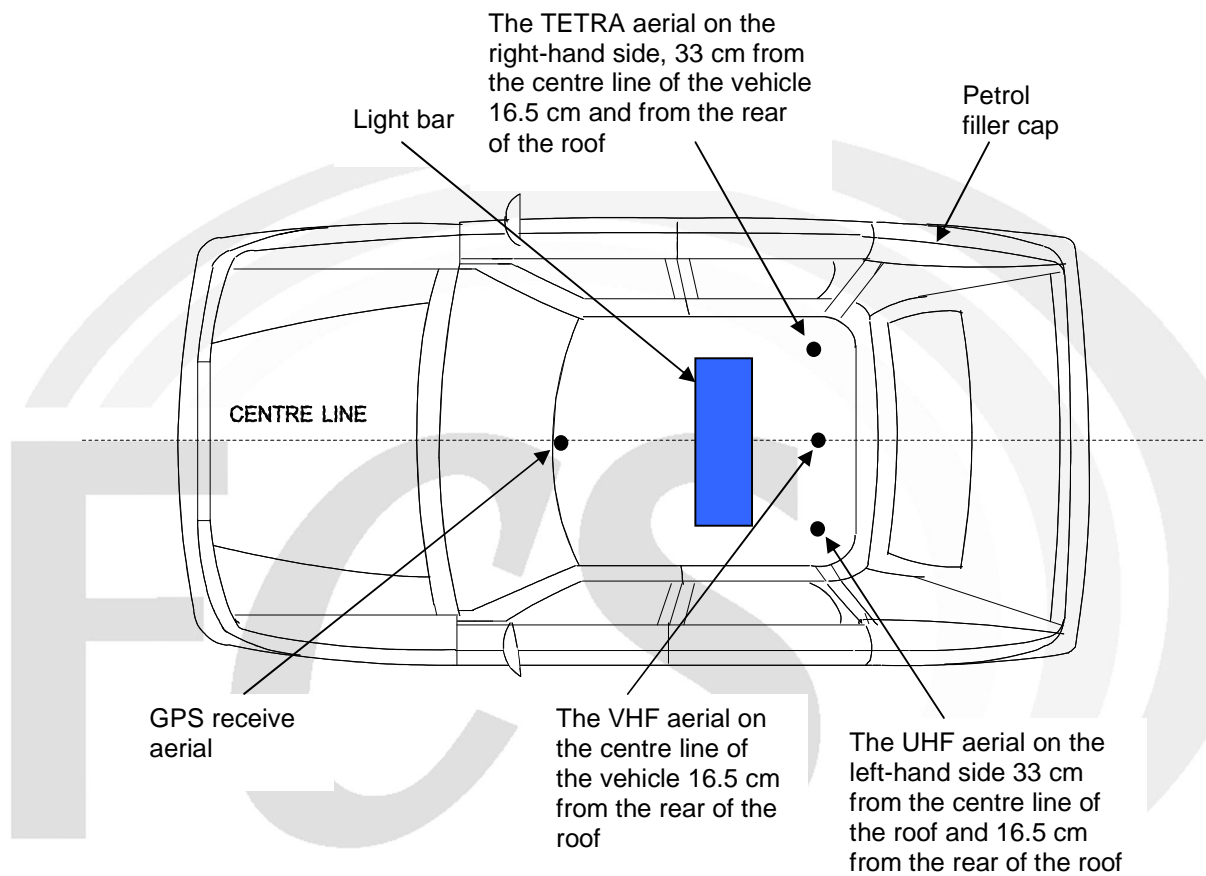

Appendix G: Covert antenna location and radiation patterns

Image and data supplied by NPIA

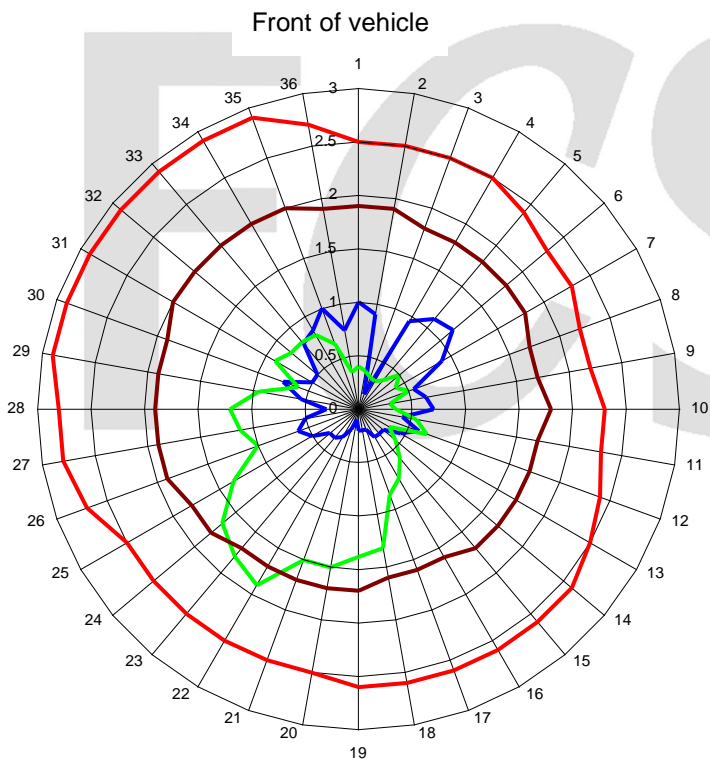
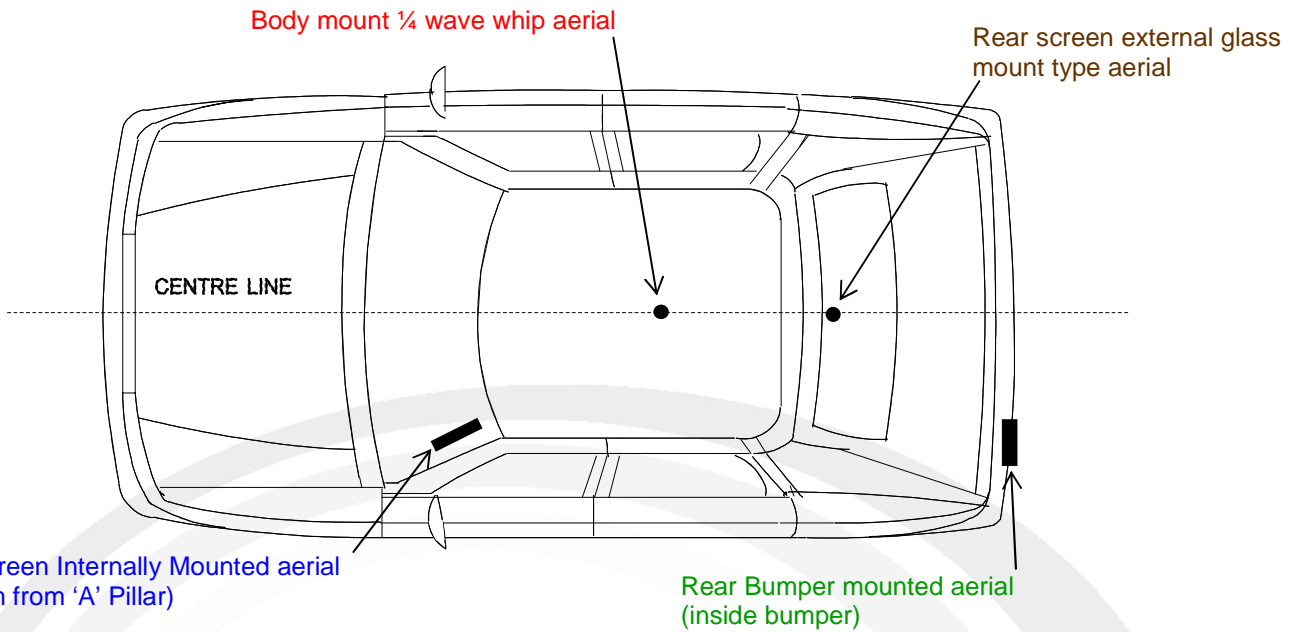

H plane polar pattern for covert antennas as shown on above vehicle, measured at 400MHz
 Blue trace Windscreen internal mount
 Green trace Rear bumper mount
 Brown trace Rear screen external glass mount
 Red trace Rear roof panel mount 1/4 wave

Appendix H: Swept area of the windscreen

This illustrates the area of the vehicle's windscreen in which no part of the installed equipment must reside in order to meet the legal requirements in section 2.3.

Conventional windscreens are divided into two areas:

1. Zone A, shown as a shaded area on the diagram below, is 290mm wide centred on the steering wheel for the depth of the area swept by the vehicle's rain wipers.
 2. The remainder of the swept area which usually includes parts of the screen each side of zone A.
- Advice from the Department for Transport stated the following two points. Note that satellite navigation and data systems are used as examples of typical devices that utilise a screen for interaction but the principle applies to any part of an installed system.
- In zone A, a satellite navigation/data system encroaching more than 10mm, and for the rest of the swept area, a satellite navigation/data system encroaching more than 40mm would be illegal.

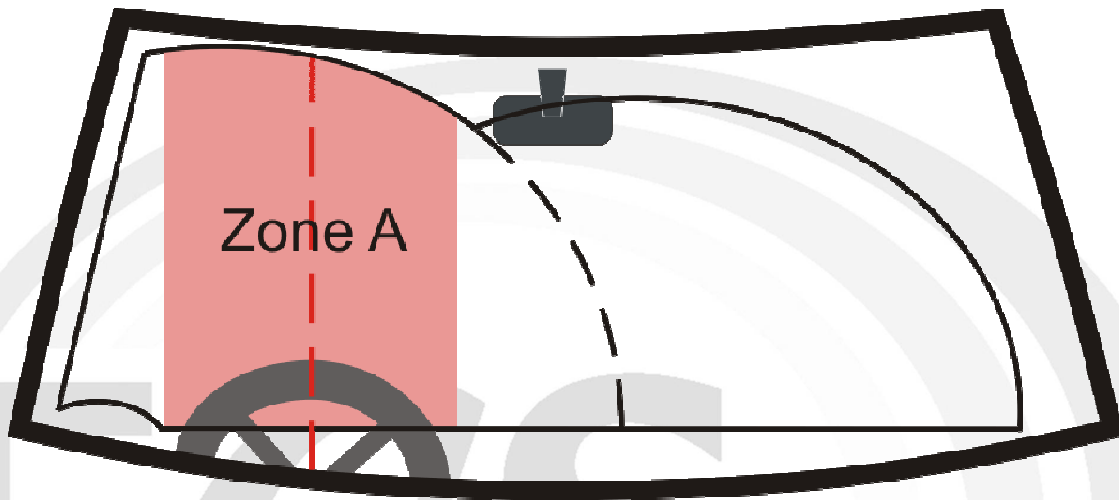

- Vehicles with satellite navigation/data systems fitted to their windscreens which are not readily removable would only fail the MOT if the satellite navigation/data system seriously restricted the driver's view.

Appendix I: Example Declaration of Conformity

ABC Electronics Ltd, Any House, Some Close,
On the Way, Town-by-Sea, West County, AB12 4NM
Tel: 01234 654321 Fax: 01234 765432

EU DECLARATION OF CONFORMITY (In accordance with ISO/IEC 17050-1:2004) Document number – 0603-CKA0009 v0.2

The Products Covered by this Declaration
ABC 1000

The EU Directives covered by this Declaration
2004/108/EC Electromagnetic Compatibility Directive (EMC)

The Basis on which Conformity is being Declared

The product identified above complies with the requirements of the above EU Directive by meeting the following standards:

Ref number	Title	Edition/Date
EN 55022	Information technology equipment. Radio disturbance characteristics. Limits and methods of measurement – class B	2006+A1:2007
EN 55024	Information technology equipment. Immunity characteristics. Limits and methods of measurement – class B	1996+A2:2003

The product is also in compliance with the essential requirements of Annex I 3.2.9 of the 2004/104/EC Automotive Directive by meeting the following standards and requirements of that directive:

Ref number	Title	Edition/Date
2004/104/EC Section 6.5 & Annex VII	Specification concerning broadband electromagnetic interference generated by ESAs Method of measurement of radiated narrowband electromagnetic emissions from electrical / electronic subassemblies	CISPR 25:2002
2004/104/EC Section 6.6 & Annex VIII	Specification concerning narrowband electromagnetic interference generated by ESAs Method of measurement of radiated broadband electromagnetic emissions from electrical / electronic subassemblies	CISPR 25:2002
2004/104/EC Section 6.8 & Annex X	Specifications concerning the immunity to transient disturbances conducted along supply lines Method(s) of testing for immunity to and emission of transients of electrical / electronic subassemblies	ISO 7637-2:2002
2004/104/EC Section 6.9 & Annex X	Specifications concerning the emission of conducted disturbances Method(s) of testing for immunity to and emission of transients of electrical / electronic subassemblies	ISO 7637-2:2002

The technical documentation required to demonstrate that the product meets the requirements of the listed directives has been compiled by the signatory below and is available for inspection by the relevant enforcement authorities. The CE mark was first applied in 2010.

The products described above comply with the essential requirements of the directives specified.

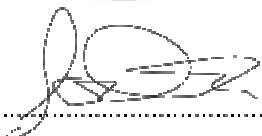
Signed: 

Name: Joe Bloggs

Authority: Managing Director

Date: 31 October 2010

ATTENTION!

The attention of the specifier, purchaser, installer, or user is drawn to special measures and limitations to use which must be observed when the product is taken into service to maintain compliance with the above directives. Details of these special measures and limitations to use are available on request, and are also contained in the product instruction manuals.

