

Experience the Legend...

ASTRO PHYSICS

State-of-the-Art Astronomical Instruments

for Discriminating Astronomers

MACH1GTO GERMAN EQUATORIAL WITH GTOCP3 SERVO MOTOR DRIVE

FOR MOUNTS SHIPPED
STARTING IN APRIL, 2009
AND ALL PREVIOUS MOUNTS.



ASTRO-PHYSICS, INC.

11250 Forest Hills Road
Machesney Park, IL 61115
Telephone: (815) 282-1513
Fax: (815) 282-9847
support@astro-physics.com
www.astro-physics.com

May 5, 2009

ASTRO-PHYSICS

***Mach1GTO* GERMAN EQUATORIAL WITH GTOCP3 SERVO MOTOR DRIVE**

ABOUT THIS MANUAL	3
<i>MACH1GTO</i> PARTS LIST	3
FEATURES AND SPECIFICATIONS	4
INTRODUCTION	5
Why Polar Alignment is Important	5
ASSEMBLY INSTRUCTIONS	6
Before You Leave Home	7
Assembling and Disassembling the Two Axes	7
Gross Latitude Adjustment	7
Assemble Pier or Tripod (purchased separately)	7
Portable Pier	7
Adjustable Wood Tripod (AWT000)	8
Adjustable Aluminum Tripod (SDS400)	8
6" <i>Eagle</i> Adjustable Folding Pier	8
Tripod Adapter	8
Attach the Mount to the Pier Post or Tripod	8
Altitude and Azimuth Adjustments - Rough polar alignment	9
Running Cables Through Your Mount	11
Attach Mounting Plate	12
Assemble Counterweight Shaft	14
Optional 10.7" x 1.875" Counterweight Shaft	14
Attach Mounting Rings (purchased separately)	15
Fine Polar Alignment	15
Methods for fine polar alignment	15
Altitude and Azimuth Adjustments	17
CLUTCH KNOBS AND BALANCING	18
R.A. and Dec. Clutch Knobs	18
Balancing Your Telescope	19
First, Balance the Declination Axis.	19
Second, Balance the Polar Axis	19
CABLE MANAGEMENT	20
Introduction to one of the Mach1GTO's most Innovative Features	20
Preparation	20
Cable Installation – the First Time	21
Disassembly and Subsequent Setups and Polar Alignments	21
A Note on the Mount's Servo "Y" Cable	22
A Few More Hints and Tricks	22
SERVO MOTOR DRIVE	23
GTO Control Box – GTOCP3	23

Lead-Free Electronics	23
R.A. and Dec. Cable Connections	23
12V Connector	23
POWER Indicator Light	24
KEYPAD Connector	24
RS-232 Connectors	24
FOCUS Connector	24
RETICLE Connector	25
AUTOGUIDER Connector	25
+6V Connector	25
N and S Switch	25
Drainage Holes	25
Pre-loaded PEMPro Curve	25
GTO KEYPAD CONTROLLER OPERATION	26
SLEWING YOUR MOUNT IN BELOW FREEZING TEMPERATURES	26
MOUNT CARE, CLEANING AND MAINTENANCE	26
Care	26
Cleaning and Touch-up	27
Mount Maintenance	27
ADDITIONAL TIPS AND SUPPORT	27
TROUBLESHOOTING	27
CHARACTERIZING THE DEC AXIS MOTIONS	30
REMESHING THE WORM GEAR AND WHEEL	31
ASTRO-PHYSICS MOUNTING PLATE FASTENER CHART	32

PLEASE RECORD THE FOLLOWING INFORMATION FOR FUTURE REFERENCE

MOUNT SERIAL NUMBER: _____

KEYPAD SERIAL NUMBER: _____

GTOCP3 SERIAL NUMBER: _____

PURCHASE DATE: _____

ASTRO-PHYSICS

Mach1GTO GERMAN EQUATORIAL WITH GTOCP3 SERVO MOTOR DRIVE

ABOUT THIS MANUAL

This version of the Mach1GTO Manual was prepared for the production run of mounts that began shipping in April of 2009. Most of the information in this manual is applicable to all Mach1GTO's that have been produced. Some of the information in this manual was simply not available when the first Mach1GTO's left our factory back in 2006. This includes information on newer accessories for the Mach1GTO that weren't available for the first production runs. We have also learned a few things through experience and the suggestions of our customers that have improved the information that is available in this manual.

We would suggest that all Mach1GTO owners adopt this manual for regular guidance with their mounts. The benefits of the improved information should easily outweigh the minor differences between mounts from earlier production runs and the current one. There will be a few things like the included serial cable and the improved AZIMUTH LOCK KNOBS that owners of older mounts will not have. In a similar fashion, owners of brand new mounts should be aware that some of the photos that were used in this manual are of mounts from earlier production runs. You may therefore see some slight differences whether you have a brand new mount, or a "first run" mount, but none of these were deemed to be of significance, and hopefully, most have been noted in the text or captions.

As always, we highly recommend the Technical Support Section of our website for the latest information and for future updated versions of this manual.

MACH1GTO PARTS LIST

- 1 Mach1GTO German Equatorial Head with Servo Drive Motors
- 1 Stainless counterweight shaft with washer stop and black plastic knob (knob has 1/4" thread)
- 1 GTO Control Box (Model GTOCP3) with pouch and control box-to-pier adapter (CBAPT)
- 1 Y cable – R.A. portion is 24.5" long and Dec portion is 40.5" long
- 1 D.C. power cord (cigarette lighter adapter on one end) - 8' long
- 1 GTO Keypad controller with 15' coiled cable and Instruction Manual
- 1 15 foot straight-through serial cable for computer connection (CABSER15)
- 1 *PulseGuide™* by Sirius Imaging – remote control utility for Windows™ PC's (CD-ROM)
- 1 Hex key set

In order to assemble your mount fully, you will need the following items sold separately:

- **Telescope mounting plate:** Many choices to fit your telescope and observing needs. See detailed section later in this manual.
- **Pier or Tripod:**
 - 6" *Eagle* Adjustable Folding Pier (EAGLE6)
 - Astro-Physics 6" Portable Pier – 6 sizes from 24" to 62" tall (6X##PP)
 - Adjustable Wood Tripod (AWT000)
 - Adjustable Aluminum Tripod (SDS400) This tripod can be used, but is not recommended for heavier loads.
 - Adapt to your own custom pier or tripod with our Tripod Adapter (ADATRI)
- **Counterweights:** 6 lb. (6SLCWT) and 9 lb. (9SLCWT) are available. (5 lb., 10 lb. and 18 lb. with optional counterweight shaft – see below.)
- **DC Power Source:** Portable rechargeable 12 volt battery pack or a power converter to convert your household AC current to DC current of 12 – 16 volts at a minimum of 5 amps. We offer a 13.8 volt 5 amp converter (PS138V5A) and a 15 volt 10 amp converter (PS15V10A).

Many of these items will be discussed throughout these instructions. Several additional options are available:

- **Optional Counterweight Shaft:** 10.7" total length x 1.875" diameter Counterweight Shaft (M1053) and Safety Stop (M12676) for use with 5 lb. (5SCWT), 10 lb. (10SCWT) and 18 lb. (18SCWT) counterweights. Handy for travel or if you already own a 900 or 1200 series mount.
- **Polar Alignment Scope:** with Illuminator (PASILL4) – for quick and easy polar alignment

- **Pier accessory trays:** A flat accessory tray with raised sides, a tray with eyepiece holes, and two support bar options are now available to fit the 6" *Eagle* Adjustable Folding Pier, some sizes of the 6" Portable Pier and both tripods. They are handy and attractive places to keep your eyepieces and other astro-gadgets close at hand!
- **Autoguiding Accessories:** Various imaging and CCD based guiding configurations can take advantage of the Mach1GTO's autoguider port. The autoguider port receptacle (RJ-11-6) uses the industry standard SBIG ST-4 wiring setup.
- **PEMPro™:** (Periodic Error Management Professional) is a Windows software application that makes it easy to characterize and reduce periodic error. PEMPro™ will analyze the performance of any mount that is equipped with a CCD camera and compatible camera control software. PEMPro™ gives you powerful tools to program your mount's periodic error correction firmware to achieve the best possible performance for your mount. PEMPro™ dramatically improves guided and unguided imaging resulting in better images and fewer lost exposures. For more information on PEMPro, see the Servo Motor Drive section later in the manual.

Note on Encoders: Mounted encoders can not be used with the *Mach1GTO*. They are not needed since the go-to functions of the mount are so much more accurate. The encoder that is built into the servo motor itself has a resolution of 0.05 arc seconds vs. 324 arc seconds for mounted encoders.

For a complete listing of our *Mach1GTO* accessories, visit our website – www.astro-physics.com

FEATURES AND SPECIFICATIONS

R.A. worm wheel:	5.9" (150 mm) 225 tooth aluminum
Dec. worm wheel:	5.9" (150 mm) 225 tooth aluminum
Worm gear:	Brass, 0.709" (18 mm) diameter
R.A. shaft:	2.36" (60 mm) diameter
R.A. Bearings	3.1" (78 mm) diameter
R.A. thrust surface:	4.1" (104 mm) diameter
Dec. shaft:	2.36" (60 mm) diameter
Dec. Bearings	3.1" (78 mm) diameter
Dec. thrust surface:	4.1" (104 mm) diameter
Periodic Error	7 arc seconds, peak-to-peak (+/- 3.5 arc sec) or less guaranteed
Counterweight shaft:	14.5" (368 mm) overall length, 13.6" (345 mm) useable length, 1.125" (29 mm) diameter, stainless steel, removable with knob and safety washer
Optional Counterweight Shaft	10.7" (272 mm) overall length, 9.625" (244 mm) useable length, 1.875" (48 mm) diameter, stainless steel, removable – requires One-piece Washerless Safety Stop (M12676). Stores inside declination axis for travel and uses same weights as 900 and 1200 series mounts.
Latitude range:	0 to 70 degrees with or without polar scope attached
Azimuth adjustment:	Approximately 25 degrees (+/- 12.5 deg. from center)
Motors:	Zero-cogging servo motors
Power Consumption:	0.4 amps at the sidereal rate 2 amps both motors slewing
Power requirements:	12 VDC, range 11.5 to 16
Weight of mount:	Total of Equatorial Head -28.5 lbs. (13.0 kg) Dec axis - 11.5 lbs. (5.2 kg) R.A axis - 17.0 lbs. (7.8 kg) (includes integral pier adapter) Counterweight shaft with washer and knob - 4.1 lbs. (1.9 kg) Optional 10.7" x 1.875" Counterweight Shaft with Safety Stop – 7.7 lbs. (3.5 kg)
Capacity of Mount:	Approximately 45 lbs. (20kg) - telescope and accessories (not including counterweights), depending on length. Will accommodate Astro-Physics and similar refractors up to 160mm f7.5, 8" - 11" SCT or 6" – 8" Mak Cas. These are only guidelines. Some telescopes are long for their weight or very heavy for their size and will require a larger mount. Note: As weight of scope and accessories increases, proper balancing becomes more critical. See section on balancing for more information.

INTRODUCTION

The Astro-Physics *Mach1GTO* - Observatory Performance in a Small Package! This is the first, compact, light-weight mounting that was designed for utmost portability while maintaining extreme rigidity and excellent tracking accuracy. No shortcuts were taken to achieve these goals. From the highly accurate fine-pitch gearbox to the precision machine tool bearings, to the innovative worm wheel and clutch design, this mount represents a new approach to this vital part of the overall imaging train.

The advent of modern CCD cameras and telescopes with high-resolution optics has placed greater demands on the ability of mountings to do their part to achieve precision tracking and guiding. At the same time, the mounting should be easy to use with adjustments and setups that are straight-forward and accurate. We have done everything possible to eliminate the frustrations and limitations inherent in a lesser mounting and so put the fun back into the hobby of amateur astronomy.

The DC servo motor drive with GTO computer system, the keypad with its digital display screen, and the included PulseGuide™ software all combine to offer extraordinary sophistication for today's observer. Whether you enjoy visual astronomy exclusively or plan an aggressive astrophotography or CCD imaging program, this mount will allow you to maximize your night out under the stars.

The advanced keypad features allow you to slew automatically to objects in a wide range of databases, as well as any R.A./Dec coordinate. A large selection of common names for stars and other objects makes your selection a snap. The rapid slew rate of 5 degrees per second (1200x) allows you to locate objects very quickly and accurately. You will be very pleased with the intuitive operation of this keypad. There are no complicated sequences of keystrokes to remember. It is so easy to use that even if you don't use it for a few months, you will feel at home with the keypad very quickly.

PulseGuide™ is a stand-alone Windows (98, ME, 2000, NT4, XP & Vista) utility that provides complete remote control of all Astro-Physics GTO mounts. It derives its name from its most distinctive feature, pulse guiding, which can improve unguided tracking. Specifically, it can help correct tracking errors caused by polar misalignment and atmospheric refraction. You can also train PulseGuide™ to track objects moving relative to the stars, such as asteroids, comets, and the moon. In addition to pulse guiding, PulseGuide™ also has many useful utility features. PulseGuide™ was written by Ray Gralak of Sirius-Imaging. Please refer to his website <http://www.pulseguide.com> for further developments and enhancements.

The *Mach1GTO* has the strength, rigidity and sophistication to tempt you to permanently place it in a state-of-the-art observatory. However, its portability and ease of setup make it the finest mount of its size for remote use in your favorite dark sky location and even for travel to exotic observing locations around the world. This is the perfect mount for a small to mid-size refractor, Newtonian, Cassegrain or astrograph.

In order to maximize your pleasure on your first night out, we recommend that you familiarize yourself with the assembly and basic operation of the mount indoors. The temperature will be comfortable, the mosquitoes at bay, and you'll have enough light to see the illustrations and read the manual. Please take particular note of counter-balancing, use of the clutches and operation of the keypad controller.

Why Polar Alignment is Important

Polar alignment compensates for the Earth's rotation. If you were to take a long exposure photograph with Polaris (often called the North Star) in the center of the field, you would discover that all stars seem to revolve around Polaris. This effect is due to the rotation of the earth on its axis. Motor driven equatorial mounts were designed to compensate for the earth's rotation by moving the telescope at the same rate and opposite to the earth's rotation. When the polar axis of the telescope is pointed at the celestial pole (polar aligned) as shown in the diagram, the mount will follow (track) the motions of the sun, moon, planets and stars. As a result, the object that you are observing will appear motionless as you observe through the eyepiece or take astrophotos.

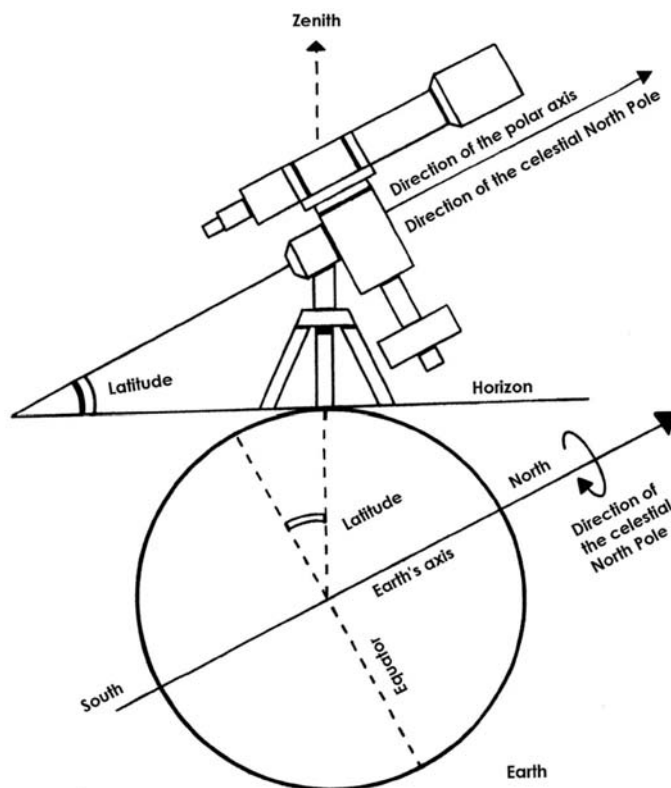

ASSEMBLY INSTRUCTIONS

Please read all instructions before attempting to set up your *Mach1GTO* mount. The *Mach1GTO* is very rugged, however like any precision instrument, it can be damaged by improper use and handling. Please refer to the following illustrations. The parts are labeled so that we can establish common terminology. Throughout the text, **SMALLCAPS** are used to refer to parts that are illustrated on this diagram.

NOTE: The following terms and abbreviations are used interchangeably in these instructions:
 polar axis = right ascension axis = R.A. axis = R.A. housing
 declination axis = dec. axis = dec. housing

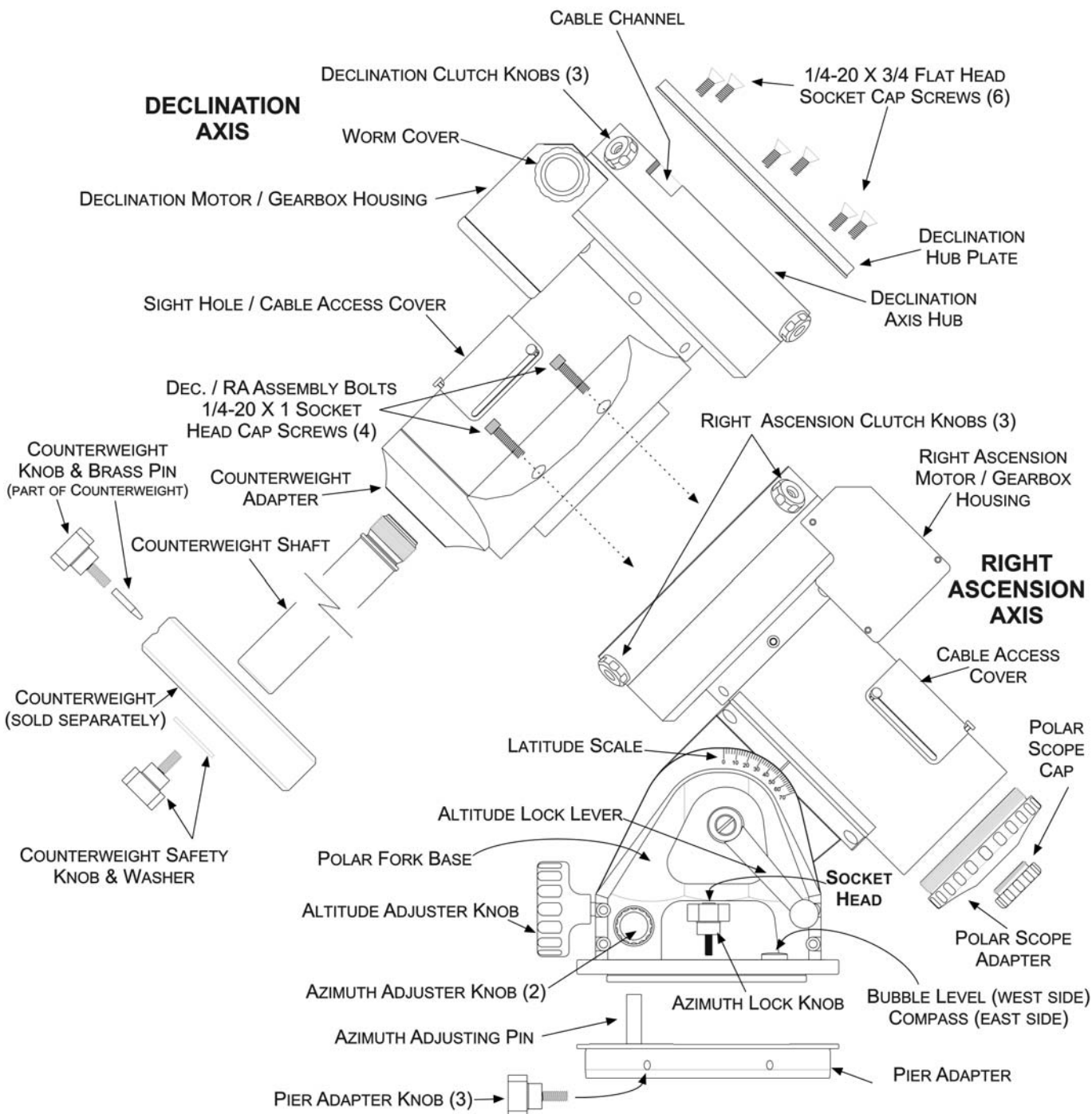

Before You Leave Home

Since most of us must set up our instruments in the dark, in the cold or while battling mosquitoes, a bit of preplanning and organization is important. There are few simple things that can be accomplished in the comfort of your home before heading outside. We would advise anyone to do a complete practice run from start to finish before venturing out into the field. This is especially important for those of you who may be new to German Equatorial Mounts.

Assembling and Disassembling the Two Axes

Because of its compact size and light weight, the *Mach1GTO* does not need to be disassembled for normal transport to and from an observing site. There will rarely be a need to disassemble the two axes. However, those of you who do disassemble your *Mach1GTO* for transport will need to be familiar with how the two axes are assembled and disassembled. When re-assembling your mount, we recommend that you fasten the RA axis onto your pier or tripod first. That way, you have a solid platform firmly holding on to your RA axis while you bolt the declination axis in place. The pier becomes your "extra set of hands."

The two axes assemble quite easily with the four 1/4-20 X 1" SOCKET HEAD CAP SCREWS shown in the Assembly Diagram on page 6. To properly line up the two axes, the RA axis must be positioned with the two pairs of screw holes on the east (2) and west (2) rather than on the north and south. In addition, the CLUTCH KNOBS of the RA axis should be at 10 o'clock, 2 o'clock and 6 o'clock as shown in the photo. The four bolt holes will not line up in any other position. To turn the RA axis to this position, loosen the three CLUTCH KNOBS and turn the axis. When in the proper position, retighten the CLUTCH KNOBS for safety.

The declination axis is placed into its position in the RA axis with the COUNTERWEIGHT ADAPTER down, and the DECLINATION HUB PLATE up as in the Assembly Diagram. Unlike the bigger 900GTO and 1200GTO mounts, the dec axis of the *Mach1GTO* must be straight and square to the RA mating surface when mounted. Don't try to tilt it into place as you would with the larger dovetailed mounts. Keep a hand on the declination axis to keep it from falling off until you have at least one of the screws loosely fastened. With the declination axis in place, insert and tighten the four 1/4-20 X 1" SOCKET HEAD CAP SCREWS.



Gross Latitude Adjustment

Unlike its bigger brothers, the 900GTO and 1200GTO, the *Mach1GTO* does not have latitude ranges that should be preset before venturing out into the field. However, you may still wish to give yourself a head start before heading out into the dark. Each side of the *Mach1GTO*'s POLAR FORK BASE is clearly marked with a LATITUDE SCALE. You can preset the mount to your latitude before leaving the house, if you wish.

Assemble Pier or Tripod (purchased separately)

Please note: Starting in 2008, the *Mach1GTO* has six attachment holes in its base to better facilitate the different pier tops. Older mounts having three attachment holes may be limited in terms of the tripod or pier leg orientations that can be chosen. Only three of the holes get used.

Portable Pier

Begin by assembling the portable pier at the desired observing location. With six attachment holes in the *Mach1GTO*'s base, you can now orient the pier with a leg to the north or south as you prefer.

1. Slide the three legs onto the nubs of the base and rotate the assembly so that one of the legs points toward the north or south. You can use either orientation in either hemisphere. Most people prefer to have one leg point toward the pole.
2. Place the pier post on the base orienting the three eyebolts directly above the legs.
3. Attach the tension rods. The turnbuckles should be drawn tight until the whole assembly is stiff enough to support your weight without movement.

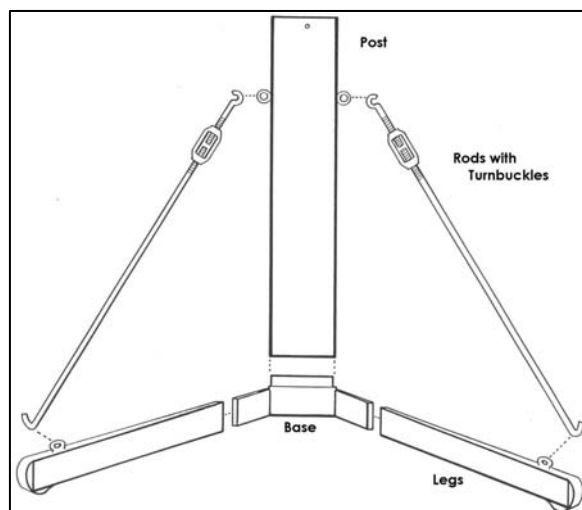

Adjustable Wood Tripod (AWT000)

Open the legs of the tripod at the desired observing location. Note which direction is north (south if you are below the equator).

1. Position the tripod with one of the legs pointing roughly toward or away from your pole.
2. Attach the shelf to each of the three legs with the knobs provided.
3. Adjust legs to the desired height and spread them fully.
4. Lock in position with the hand knobs and make sure that leg clamps are tight.

Note: Your tripod must be equipped with the Tripod Adapter (ADATRI) to mount the *Mach1GTO*. If you purchased your tripod from Astro-Physics, it came with this adapter already installed.

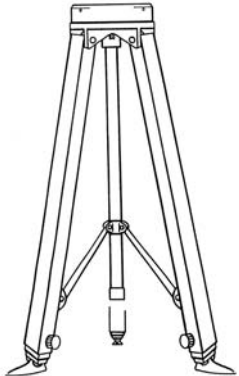
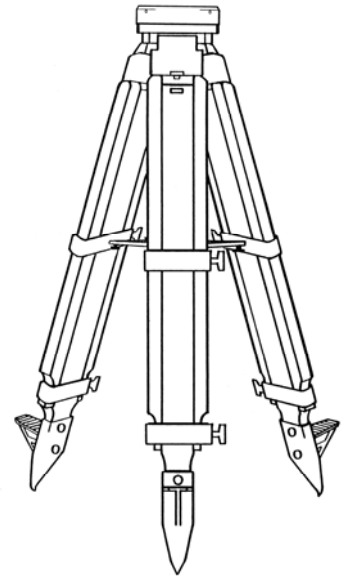

Adjustable Aluminum Tripod (SDS400)

Loosen the clamp on the support and spread the legs to the desired position. Extend the legs to the desired height and clamp everything tightly. Point one of the legs toward the north (or south) pole.

Note: The Adjustable Aluminum Tripod is not suitable for the heavier loads that the *Mach1GTO* can carry. It is usable for setups with total instrument weight of less than 20 lbs. or if portability is of critical importance. Also, see the note above regarding the Tripod Adapter (ADATRI).

6" Eagle Adjustable Folding Pier

Assembly instructions for the 6" *Eagle* Adjustable Folding Pier are included with the pier. Please refer to those instructions for assembly, adjustment and leveling procedures. Your *Mach1GTO* will fit into the 6" *Eagle* Adjustable Folding Pier without any additional adapters. Simply set the mount into the open top of the pier and attach with the three PIER ADAPTER KNOBS included with the mount.



ADATRI Tripod Adapter
for 400, 600 & Mach1GTO

Bolt Circle Diameter = 5.110"
Drilled at 120°

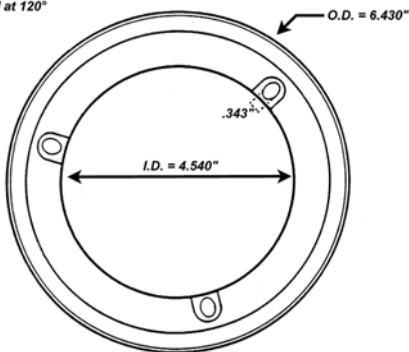

See the website for details.

Tripod Adapter

If you have your own custom pier or tripod with a flat surface on top, you can use our Tripod Adapter (ADATRI) for mounting the *Mach1GTO*. We also offer a separate adapter that can be used in conjunction with this Tripod Adapter to attach to a Losmandy Heavy Duty Tripod or a Losmandy Meade Tripod Adapter (LT2APM).

Attach the Mount to the Pier Post or Tripod

The PIER ADAPTER is already attached to your *Mach1GTO*. Starting in 2008, there are six attachment holes in the PIER ADAPTER base for positioning flexibility. You, of course, only use three of them (every 120°) with the three provided PIER ADAPTER KNOBS. Remove the three PIER ADAPTER KNOBS from the PIER ADAPTER. Simply set the mount into the pier post on

your 6" *Eagle* Adjustable Folding Pier, your Astro-Physics Portable Pier, or the adapter of your Adjustable Wood Tripod. Fasten with the three PIER ADAPTER KNOBS. If you are attaching the Control Box Adapter or a Tray Support Bar at the top of your pier or tripod, do that now. (Note: photo on next page is of an earlier vintage with three pier attachment holes.)

Altitude and Azimuth Adjustments - Rough polar alignment

For rough polar alignment, your goal is to sight the celestial pole when looking through the polar alignment sight hole in the center of the polar axis. You will need to make altitude (up/down) and azimuth (side-to-side) adjustments to the position of the mount. Before beginning, make sure that the mount is pointing roughly north using the built-in compass and that your pier or tripod is level using the mount's built-in bubble level. (Refer to note below.)

Remember that magnetic north is not the same as true north and varies both with time and with your

location. In the fall of 2006, on the northeast tip of Maine, for example, magnetic north is west of true north by a whopping 18 1/2 degrees! On Mauna Kea in Hawaii, by contrast, magnetic north is about 9 1/2 degrees east of true north. Observers along the Mississippi River are lucky and are nearly dead on.

These values change by several minutes every year. With experience at a particular site, however, you will soon learn to use the compass to find true north. (You will know just how far off magnetic north is for your location.) In addition, there is a website funded by our U.S. tax dollars that will compute the declination of magnetic north relative to true north for any location that you input. The link is as follows:

<http://www.ngdc.noaa.gov/seg/geomag/jsp/Declination.jsp>

Note on Bubble Levels: It is possible to achieve perfect polar alignment without having the pier level, but it is slightly more difficult. With a pier that is not level, each adjustment in azimuth also causes a minor shift in altitude and vice versa. This is why we have included the bubble level on the *Mach1GTO*. Keep in mind that unless you are a serious astrophotographer or imager, "perfect" polar alignment is not critical.

We recommend that you do your rough polar alignment with the mount only since you will be making major adjustments to the position of the mount at this time. The remainder of the equipment: telescope, finder, camera or eyepiece and counterweights will add considerable weight and require more hand effort to make the adjustments. Later, you will do your final polar alignment with the telescope and counterweights attached, but the adjustments will be small.

Note: The illustrations below show only the RA axis. This was done for clarity since the declination axis blocks the view into the POLAR FORK BASE. You will, of course, be doing your rough alignment with the mount assembled.

1. If the Polar Scope (PASILL4 or earlier model) is installed, you may remove it to complete these steps.
2. Remove the POLAR SCOPE CAP (unless a polar scope was installed). If you examine the polar axis assembly, you will see that the center of the R.A. shaft is hollow. Additionally, if you look at the dec axis, you will see that it has a sliding cover (the SIGHT HOLE / CABLE ACCESS COVER). By sliding this cover to the "open" position, you open a sight line through the RA axis and out into the sky. For your rough alignment, you will peer through this sight tube and attempt to center Polaris.



3. **Azimuth adjustments:** To begin, move or turn the entire pier or tripod east or west until the mount is oriented approximately towards the pole (an imaginary line drawn through the hollow shaft). If you are using the 6" Eagle Adjustable Folding Pier, you can take advantage of the Azimuth Adjustment Slots for your rough polar alignment. The compass on the east side of the POLAR FORK BASE will help you. Also, if you want the mount to be level, check the bubble level again after moving everything. (Remember, mount leveling is not critical for most observers.)

Mach1GTO Azimuth Adjustment Range 25 degrees (+/- 12.5 deg. from center)



Azimuth adjusted to the east.



Mount centered in azimuth.



Azimuth adjusted to the west.

Loosen the two AZIMUTH LOCK KNOBS (one on each side of the POLAR FORK BASE). Note that starting with the 2009 production run we began supplying an improved knob with an integral socket cap screw. This allows you to more securely lock down the mount to its pier adapter using a 3/16" hex key from the supplied set. The photos above show the older style AZIMUTH LOCK KNOBS. Use the two fine AZIMUTH ADJUSTER KNOBS, one on each side of the mount, to make adjustments. You must back off the opposing azimuth knob in order to move the other knob in that direction. Please refer to the photos above. These photos also illustrate the 25 degrees of azimuth adjustment possible with this mount. If you are finished, i.e. for casual observing, tighten the AZIMUTH LOCK KNOBS and make sure that the AZIMUTH ADJUSTER KNOB you were backing off in the above adjustment is snugged against the AZIMUTH ADJUSTING PIN. If you will be further refining your alignment, just snug down the AZIMUTH LOCK KNOBS.

One full turn of the AZIMUTH ADJUSTER KNOB is approximately 1.37 degrees (82 arc minutes)

4. **Altitude (latitude) adjustments:** The altitude adjustment mechanism on the Mach1GTO has two components. There is a large ALTITUDE ADJUSTMENT KNOB on the front (north) side of the mount for making the adjustments. The second part is the innovative tool-free ALTITUDE LOCKING LEVER on the west side of the POLAR FORK BASE. This lever has a spring-loaded, ratchet-type action that allowed us to use a longer handle for leverage than would otherwise have been possible. Pulling the handle out away from the base (pull it to the west) will disengage the handle so that it will turn freely in either direction. Using this feature, you simply ratchet it tight when your altitude is set, or ratchet it loose if you need to make an adjustment. To start your altitude adjustment, loosen the ALTITUDE LOCKING LEVER. Move the polar axis up or down with the large ALTITUDE ADJUSTMENT KNOB located in the front of the polar axis assembly. When your altitude is set, lock it with the locking lever. In addition, if you are using an Astro-Physics Portable Pier, we have found that using the turnbuckle on the north leg of the pier also can make fine altitude adjustments, if used.

One turn of the ALTITUDE ADJUSTMENT KNOB is approximately 1.04 degrees (62 arc minutes).



ALTITUDE LOCK LEVER
Operation

Mach1GTO Latitude Adjustment Range 0 degrees to 70degrees



0 Degrees Latitude



35 Degrees Latitude



70 Degrees Latitude

Please note: photos are from first production run. Later production runs incorporated a Polar Scope Adapter with a knurled grip.

5. Continue your azimuth and altitude adjustments until you can sight Polaris in the polar alignment sight hole. Try to center it roughly in the sight hole. A very dim red light may help you see enough of the hollow shaft to help you with centering without obscuring Polaris. At this point, you have achieved a rough polar alignment, which may be sufficient for casual visual observations, if you are not planning to slew to target objects with the keypad. When the R.A. motor is engaged (the power is plugged in), it will compensate for the rotation of the earth and keep the target object within the eyepiece field-of-view. Your target object will slowly drift since polar alignment at this stage is only approximate. However, you can make corrections with the N-S-E-W buttons of your keypad controller.
6. Tighten the ALTITUDE LOCKING LEVER and AZIMUTH LOCK KNOBS by hand.

Running Cables Through Your Mount

If you plan to route cables through your mount, this is the point in your work flow where you will want to do so. Please refer to the later section of this manual entitled "Cable Management" for a full discussion of your options. We mention it here because cables that will be routed through the CABLE CHANNELS on the DECLINATION AXIS HUB will need to be installed before the mounting plate is attached. The servo "Y" cable can be installed with the mounting plate attached.

Attach Mounting Plate

(purchased separately)

Several mounting plates (also called cradle plates) are available for the *Mach1GTO* mount. If you own more than one instrument, you may need more than one plate, or you may wish to use one of the dovetail mounting plate options with more than one male dovetail sliding bar. Attach your mounting plate with the screws provided with the plate. It is important to use the proper screws, please refer to the instruction sheet entitled "*Mounting Plate Fastener Chart*." This chart is available at the end of this manual and in the technical support section of our website.

15" FLAT MOUNTING PLATE (FP1500)

This plate is 15" long by 4.6" wide by 0.5" thick. Two pairs of keyhole slots that measure 3.2" between centers are provided. The pairs are 13.75" apart. You can drill additional holes to suit your needs. This plate also fits the 400, 600E, 900 and 1200 German Equatorial mounts.

This plate has a hole spacing of 13.75". This allows the use of the 15" dovetail plate (DOVE15) on top of your instrument as an accessory plate.

Attach this plate with four 1/4-20 x 5/8" socket head cap screws

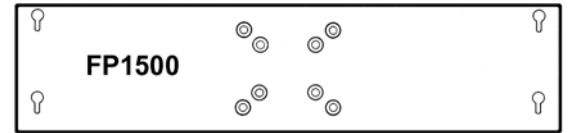

18" FLAT MOUNTING PLATE (FP1800)

This plate is 18" long and 7.5" at its widest point in the center. The width of the plate tapers to 5.5" at each end. Four pairs of keyhole slots that measure 3.2" between centers are provided. The two inner pairs are 13.75" apart and the outer two pairs are 17" apart. You can drill additional holes to suit your needs. This plate also fits the 900 and 1200 German Equatorials.

Attach this plate with four 1/4-20 x 1 1/4" flat head socket cap screws. Leave two screws in the dec hub's top plate. (see note at end of this section)

This plate has a hole spacing of 13.75". This allows the use of the 15" dovetail plate (DOVE15) on top of your instrument as an accessory plate.

Note: This is a very large plate for the *Mach1GTO*. If your instrument requires such a large plate, it may be too large for this mount.

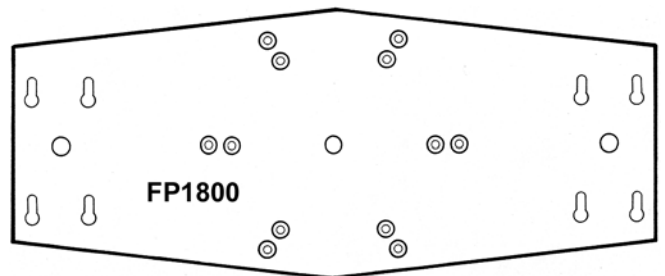

15" RIBBED MOUNTING PLATE (900RP)

The finished plate is 0.75" thick, 15" long and 6.5" at its widest point. The width of the plate tapers to 4.75". A pair of keyhole slots that measure 3.2" between centers are provided at each end. The distance between these pairs of holes is 13.75". Due to the ribbed structure, you may not be able to drill additional holes to suit your mounting rings. The plate weighs 2.3 lbs.

Attach this plate with four 1/4-20 x 1 1/4" flat head socket cap screws. Leave two screws in the dec hub's top plate. (see below) Note that the plate is asymmetrical. In most cases, orient the plate so that the long end points toward the sky. You can also turn the plate in the other direction to balance your scope.

This plate has a hole spacing of 13.75". This allows the use of the 15" dovetail plate (DOVE15) on top of your instrument as an accessory plate.

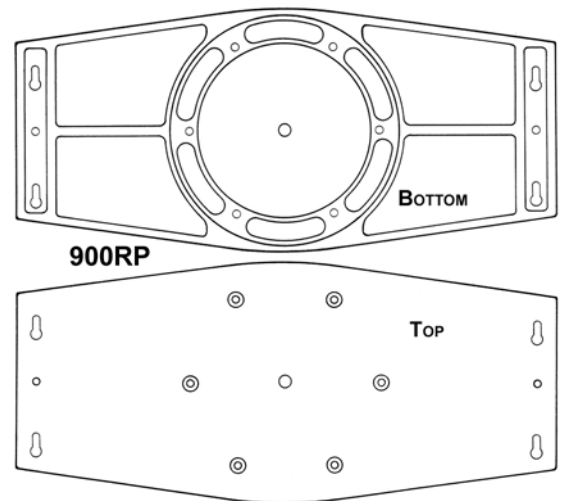

8" ASTRO-PHYSICS DOVETAIL MOUNTING PLATE (DOVE08) with Q4047 ADAPTER

This versatile plate is suited for the 105 f6 Traveler and 130 refractors (we prefer the 15" Dovetail Plate for most applications of the 130 f8 StarFire EDT) and other short instruments. The knob assembly features a brass pin with a tapered end to hold your sliding bar firmly without marring the aluminum. Use with the 7" or 10" sliding bars (SB0800 or SB1000), which are sold separately. Repositioning the sliding bar will aid in adjusting the balance of your instrument.

Note: This plate requires the use of the Q4047 adapter with the *Mach1GTO* mount to provide clearance for the knobs.

As an accessory plate - Attach to the top of our Astro-Physics mounting rings (tube diameters 5"-8") or rings from Parallax Instruments that have the Astro-Physics hole pattern (you can request it). You must also use a sliding bar on the bottom of the rings with the same distance (6.3" from center to center), i.e. the SB0800 or SB1000.

Attach the Q4047 to the mount using four of the six outside holes and four 1/4-20 x 1" flat head socket cap screws. Attach the DOVE08 to the Q4047 with four 1/4-20 x 5/8 socket head cap screws.

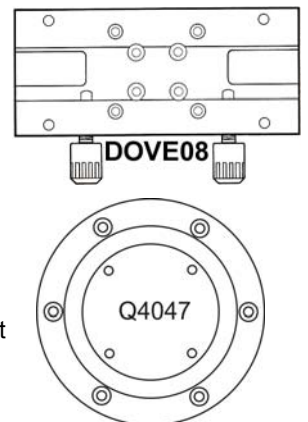

15" ASTRO-PHYSICS DOVETAIL (DOVE15) FOR 15" SLIDING BAR (SB1500)

The 15" version of our dovetail plate is suited for the 130 f8 StarFire EDT, 155 f7 StarFire EDFs, Takahashi scopes and other instruments of similar size. The two knob assemblies each feature a brass pin with a tapered end to hold your sliding bar firmly without marring the aluminum. Use with the 15" Sliding Bar (SB1500), which is sold separately (**NOT** for use with Losmandy "D" plates). Also makes a great accessory plate when used with either the 900RP, the FP1500, the FP1800 (with rings mounted to inside holes) or another DOVE15.

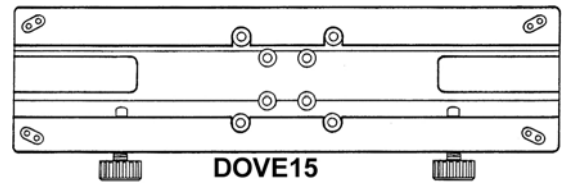

Attach with four 1/4-20 x 1/2" flat head socket cap screws.

8.5" DOVETAIL FOR LOSMANDY D SERIES PLATE (DOVELM2)

This Astro-Physics plate attaches to the 400, 600E, 900, 1200 and Mach1GTO mounts. If you already own one of the Losmandy DAP series (fits Astro-Physics refractors), DC series (for Celestron 8" 9.25" or 11" SCTs) or DM series (for Meade 8" and 10" SCTs) plates, you should consider this plate or the longer DOVELM16S or DOVELM162. For larger size SCTs we recommend the *Easy-Balance* DOVELM162 – see below.

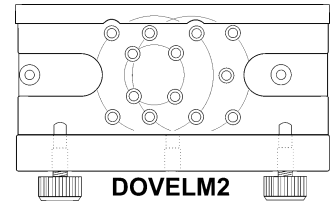

Note that the two larger bolt-hole patterns are offset from the center. This allows you to position the plate either forward or backward depending on the balance point of your telescope. Attach this plate with four 1/4-20 x 5/8" socket head cap screws.

16" EASY-BALANCE DOVETAIL FOR MACH1GTO, 900 AND 1200 MOUNTS AND LOSMANDY D SERIES PLATES (DOVELM162)

This Astro-Physics plate was introduced in February, 2009. The DOVELM162 provides a multitude of mount attachment options, and was specifically designed to meet the balancing demands of "back-end-heavy" instruments like SCTs and Richey-Chrétiens, especially those with heavy imaging gear hanging off the back! This plate has small knobs to avoid interference with the declination hub, but the knobs have cap screws in the ends that accept a 3/16 hex wrench for extremely secure clamping of your instrument. Additional features include ribbed structure underneath to reduce weight and tapped 10-32 holes in the side for cable attachment.

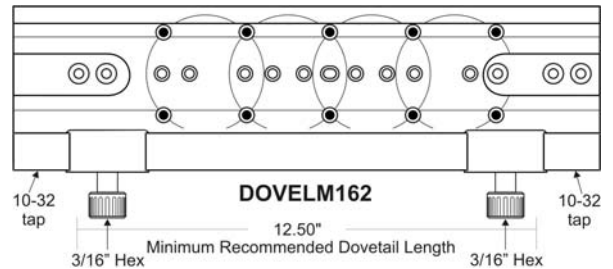

Note that the bolt-hole patterns are marked with scribe cuts. Attach this plate with four 1/4-20 x 1" socket head cap screws.

16" DOVETAIL FOR LOSMANDY D SERIES PLATES (DOVELM16S)

This Astro-Physics plate attaches to the 900 and Mach1GTO mounts. If you already own one of the longer Losmandy DAP series (fits larger Astro-Physics refractors), DC series (for Celestron 8" or 9.25" SCTs) or DM series (for Meade 8", and 10" SCTs) plates, this is the mounting plate for you.

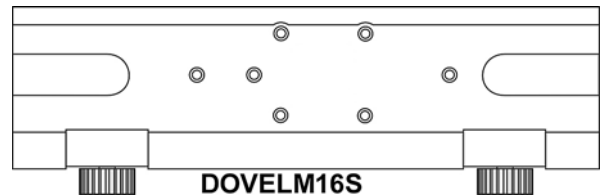

Note that the bolt-hole pattern is offset from the center. This allows you to position the plate either slightly forward or backward depending on the balance point of your telescope. Attach this plate with four 1/4-20 x 7/8" socket head cap screws. NOTE: As of this writing, this plate will be available as long as quantities last. It is being phased out in favor of the DOVELM162 (above).

NOTES ON ATTACHING THE ABOVE MOUNTING PLATES:

Three of the components listed above have six mounting holes that match the six screw holes that hold the DECLINATION HUB PLATE onto the hub of the Mach1GTO's Dec axis. (FP1800, 900RP and Q4047) We recommend that you use only four of these holes to mount your plate. Remove four of the screws that hold the DECLINATION HUB PLATE in place. They will be replaced by the four screws that hold the mounting plate down. The remaining two can then still hold the DECLINATION HUB PLATE in place on the DECLINATION AXIS HUB while the mounting plate is being attached. The four remaining holes are more than adequate to hold the plate securely on the mount. It really doesn't matter which four you choose, but the two screws left to hold the DECLINATION HUB PLATE in place should probably be opposite each other. You may also remove the DECLINATION HUB PLATE if you wish.

You will also notice that in addition to the four holes that make up the inside pattern on the DECLINATION HUB PLATE, there is an extra hole that matches an extra hole found in two of the Losmandy style plates (DOVELM2 and DOVELM16S). This fifth hole is not used if the four regular holes are in use. However, if you lose a mounting screw, it can be used in place of the two normal holes on that end of the plate to make a very solid 3 point attachment.

Mounting Plate Orientation

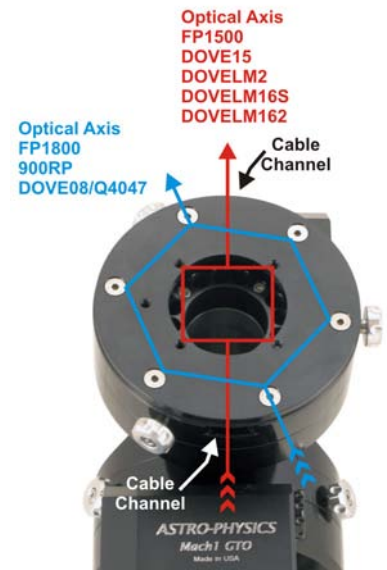

While there is no required orientation of the mounting plate, we have found the two orientations in the photo on the previous page to work very well. The advantage to the pictured orientations is primarily in the ease of working the clutch knobs, and in providing the easiest routing for cables. Note that your DECLINATION HUB PLATE may not be oriented properly for this arrangement. If not, simply remove and rotate it into this position with respect to the clutch knobs and cable channels. As pictured on the previous page, the two Cable Channels are at 12 o'clock and 6 o'clock. The clutch knobs are at 3, 7 and 11 o'clock. The optical axis for a plate with the four-hole pattern is directly over the cable channels. Plates with the six-hole pattern are rotated a bit to allow the attachment bolts to clear the Cable Channels

Assemble Counterweight Shaft

IMPORTANT: Always attach the counterweights before mounting the telescope to the cradle plate to prevent sudden movement of an unbalanced tube assembly, which may cause damage or injury. Remember counterweights are heavy and will hurt if they fall on your foot.

1. Thread the COUNTERWEIGHT SHAFT onto the Dec. axis. Be careful to NOT cross-thread the shaft in the adapter!
2. Remove the COUNTERWEIGHT SAFETY KNOB AND WASHER (or the one-piece Safety Stop if you are using the 1.875" diameter shaft) from the base of the COUNTERWEIGHT SHAFT. Add sufficient COUNTERWEIGHTS (purchased separately) to the COUNTERWEIGHT SHAFT to balance the telescope you intend to use. Loosen the counterweight knob and hold the counterweight with the knob pointing downward so that the brass pin will move from the center opening allowing the counterweight to slide into position. Always use two hands to attach or move the counterweights on the shaft. It is advisable to have the counterweight knob pointing down toward the pier. This will minimize the chance of accidentally loosening the counterweight during the observing session.
3. **Reattach the COUNTERWEIGHT SAFETY KNOB AND WASHER to the end of the COUNTERWEIGHT SHAFT.** This will help to prevent injury if someone accidentally loosens the COUNTERWEIGHT KNOB.

NOTE: A firm tightening of the COUNTERWEIGHT KNOB will not damage the surface of the COUNTERWEIGHT SHAFT. The pin that tightens against the stainless counterweight shaft is constructed of brass. Likewise, the bronze sleeve that has been press fitted into the center of the COUNTERWEIGHT will prevent marring of the shaft as you move the COUNTERWEIGHTS up and down.

Optional 10.7" x 1.875" Counterweight Shaft



The optional 10.7" total length x 1.875" diameter Counterweight Shaft offers some additional capabilities and considerations. The shaft installs in the same way as the standard shaft, but instead of a SAFETY KNOB AND WASHER, this shaft uses the One Piece Washerless Safety Stop (M12676) at the end of the shaft. For safety, you **MUST** use this Safety Stop! There are two main reasons why a person might choose the Optional Counterweight Shaft over the standard 14.5" x 1.125" shaft:

1. Owners of 900 or 1200 series mounts might prefer to purchase the optional shaft because it uses the same 10 lb. (10SCWT) and 18 lb. (18SCWT) counterweights that those bigger mounts use. These counterweights have larger 1.875" diameter center holes. Please note that this shaft weighs in at a hefty 7.7 lbs. including the safety stop. To facilitate lighter instruments, we have added a 5 lb. counterweight (5SCWT) to the product line to join the other two weights with the larger center holes.
2. Owners who plan to use their Mach1GTO for long-distance travel may wish to purchase this shaft for a more compact fit in a travel case. The 10.7" shaft was specifically designed to fit inside the hollow declination shaft and screw into the COUNTERWEIGHT ADAPTER from the back side. When fully screwed into the adapter, and with the Safety Stop in place, the whole thing only protrudes about 3/4" from the face of the DECLINATION HUB PLATE. To prevent you from



accidentally getting the shaft stuck inside the dec axis, we added a socket head screw to the end of the shaft. Simply use your 1/4" hex key to break it loose if needed.

Keep in mind that the combined weight of the equatorial head and shaft will be 36.2 lbs. not counting the GTOCP3 control box, keypad, cables or the travel case itself. With the mount's two axes separated, and the shaft thus stored, it will all fit neatly into a case that should fit

into an overhead luggage compartment, but you still have to be able to lift it up that high! You must also be aware of all rules and regulations regarding weight limits and allowable case sizes, not to mention potential security problems. Please do your homework before trying to take a trip with your valuable astronomical equipment. We have designed the mount to be portable, but we cannot guarantee that you will be allowed to carry it with you.

One final caution: This is a “really cool” feature, but remember, you will need to remove the mounting plate to take advantage of this capability. It will be great for long-distance travel, but you may not want to store the shaft inside the dec axis for trips to and from your favorite local dark site.



Attach Mounting Rings (purchased separately)

Flat and ribbed plates: constructed with keyhole slots at the location where your mounting rings attach. This feature enables you to partially loosen the screws on your rings just enough to insert them into the larger part of the keyhole, then slide the rings to the narrow part and tighten them with a hex key. You can even accomplish this with the rings on the scope, although this maneuver may be difficult to accomplish with a large, heavy instrument.

We prefer this keyhole method to the standard way of completely removing the screws and possibly dropping them in the grass.

Astro-Physics or Losmandy Dovetail Plates: Attach the mounting rings to the male dovetail plate (sliding bar).

Fine Polar Alignment

For casual observation, you may skip most of this section and simply start observing. Don't forget to tighten your ALTITUDE LOCKING LEVER and AZIMUTH LOCK KNOBS and make sure both of your AZIMUTH ADJUSTER KNOBS are snugged against the AZIMUTH ADJUSTING PIN. Move the telescope manually or by using the N-S-E-W buttons of the keypad. The keypad and GTO Servo Control Box will function as soon as they are plugged in. That means that the R.A. axis will be tracking up to the limits of your polar alignment. However, if you plan to use any of the go-to functions of the *Mach1GTO* or do astrophotography, you must perform a more accurate polar alignment.

Methods for fine polar alignment

- Polar Alignment Scope – Use our optional polar scope [PASILL4 or PASILL3 (prior version)] models – earlier polar alignment scopes cannot be used as effectively with the Mach1GTO as explained later in this section). This will allow you to quickly align your mount on the pole stars. The reticle was designed for use in both the Northern and Southern hemispheres. Even users of the GTO computerized mounts will find these polar scopes useful, particularly if your telescope is not orthogonal to the mount (please refer to the keypad manual for a discussion of orthogonality). If you have a PASILL4 or PASILL3, please read the instructions sheets that came with it with the following modification:

The reason that the Mach1GTO requires either the PASILL4 or PASILL3, is that these polar scopes have reticle housings that turn freely in their collars. Unlike all the other mounts that we have produced since the early 1990's, the Mach1GTO's polar axis shaft does not reach all the way to the bottom of the polar axis housing. With these other mounts, the polar scope was actually screwed into the end of the polar axis shaft. If you turned the polar (RA) axis, the polar scope turned as well. With the Mach1GTO, the polar scope attaches to the Polar Scope Adapter, which is, in turn, attached to the polar axis housing, not the polar shaft. Turning the polar axis does NOT also turn the polar scope. To use the polar scope with your Mach1GTO, simply turn the polar scope's reticle housing instead of the RA axis as instructed during the final stages of polar alignment. If you started with the reticle properly oriented these will be small movements.



It is possible to use an older model polar scope (PASILL or PASILL2), but they may be a bit less accurate. To use one of these earlier polar scopes, screw the unit into the adapter, and then back it off to align Polaris' relative position to the pole. Proceed normally turning the polar scope wherever the instructions say to turn the RA axis. Since the scope won't be screwed in tight, you may have a bit of sag that will slightly reduce your accuracy.

- GTO Keypad – Please refer to the instruction manual for the GTO Keypad and read the sections from “Getting Started” through “Alternate Polar Calibration Routines & Tips.” Also, be sure to read the Keypad Version 4.17 Addendum. Here are summary descriptions of several techniques for polar alignment from the Keypad Manual and Addendum.
 - The Keypad startup routine provides two methods: The North Polar Calibrate and the Two Star Calibration. These two polar alignment methods were really designed for quick coarse alignment in the field with portable setups. They are most appropriate for visual observers. The Two Star Method is generally the better of the two as it is less affected by orthogonality issues.
 - The Daytime Routine (See “Polar Aligning in the Daytime”), is a great trick for daytime setup. In addition, it is the recommended first step in alignment for anyone in the southern hemisphere, and for owners of the 3600GTO. Even those in the south who own our polar scope will find it helpful, since it will generally put the rather difficult-to-spot southern stars into the polar scope's field of view.
 - The original GTO Quick Star Drift Method of Polar Alignment that takes advantage of the Meridian Delay feature of the Astro-Physics Servo System is also included in considerable detail in the Keypad Manual. A table of suggested stars is found in Appendix I of the manual.
 - Saving the best for last, we have also included a second Revised GTO Quick Star Drift Method that was conceived for use with a finder scope. This method is detailed in the Keypad Version 4.17 Addendum and includes a one-page Quick Reference Sheet to use once you are familiar with the method. By using a finder scope, you are able to remove orthogonality issues from the process, making subsequent alignments much easier.

For our testing purposes here at Astro-Physics, using one of the first production 3600GTO's, we obtained accurate enough polar alignment for extensive imaging (with a focal length of 3810 mm!) using the Daytime Routine, followed by the Revised GTO Quick Star Drift Method, and did so in less than one half hour! The combination of Daytime Routine followed by the Revised GTO Quick Star Drift Method is our recommended procedure for anyone in the southern hemisphere, or anyone who finds their view of the pole obstructed.
- Computer Software Solutions – There are many software packages that include aids to polar alignment. Some work better than others. Most of them have shortcomings, especially if there is any orthogonality error or flexure in your system. We have seen customers practically tear their hair out trying to get good alignment using software. Do not be fooled into thinking that your alignment is perfect simply because a piece of software told you so. Polar Alignment is, after all, entirely a mechanical issue. With the creation of the Revised GTO Quick Star Drift Method, Roland and other staff members here at Astro-Physics no longer even bother with software for polar alignment. Having said that, here are some of the software options that are available:
 - We suggest that you refer to detailed instructions in the GTO Keypad manual for a method that utilizes CCDOPS from Santa Barbara Instrument Group (SBIG) for precise polar alignment. This method is basically traditional drift alignment with CCDOPS and your camera precisely measuring the drift for you.
 - There is a Polar Alignment Wizard in the Full Version of PEMPro 2.x. Owners of the Mach1GTO can purchase PEMPro from our website or from the the CCDWare website: www.ccdware.com This wizard is quick and easy and gives excellent results! Details are in the PEMPro documentation.
 - There are also other similar alignment procedures, including one in MAXIM DL from Diffraction Limited. Numerous other software solutions are also available.
- Star Drift method – Traditionally, this very time-consuming procedure has been regarded as the most accurate method of polar alignment. However, if you are using the old method of drift alignment (star near eastern horizon, etc), you are doomed to failure. To obtain more accurate results, choose stars somewhere near the celestial equator due south or slightly east and west, but not below 45 degrees elevation. If you attempt to drift align below that, you will encounter atmospheric refraction, which skews your alignment.

For portable setups, we believe that our two GTO Quick Star Drift Methods are much more practical approaches in terms of providing highly accurate alignment and still leaving enough time to actually get some imaging done. A permanent observatory setup where long unguided exposures are taken may still benefit from a final tweaking using the traditional star drift method.
- Helpful Advice – Members of the ap-gto Yahoo group occasionally discuss alternative methods of polar alignment that they have found helpful. We suggest that you participate in this Internet discussion group. Follow the links from the sidebar of our website to find the group.

Altitude and Azimuth Adjustments

1. For fine alignment, slightly loosen the ALTITUDE LOCKING LEVER and barely loosen the two AZIMUTH LOCK KNOBS. You should feel considerable resistance from these locking devices when making final precise adjustments. If the locking devices are loose, the alignment may shift when you finally do lock them down undoing all your efforts to obtain a precise alignment. When adjusting azimuth, remember that you must back off with one AZIMUTH ADJUSTER KNOB to move the other.
2. Follow one of the methods of fine polar alignment mentioned above.
3. When polar alignment has been achieved, tighten the ALTITUDE LOCK LEVER. Make sure that the AZIMUTH ADJUSTER KNOB that you have been backing off is turned back in until it is against the AZIMUTH ADJUSTING PIN so that the mount is held firmly in azimuth. Tighten the AZIMUTH LOCK KNOBS.
4. For a portable installation, the ALTITUDE LOCKING LEVER and the AZIMUTH ADJUSTER KNOBS do not need excessive tightening. You can tighten with more force for a permanent installation.

AZIMUTH HINT: When you are at the fine stages of azimuth adjustment, it is helpful to change your approach slightly. Instead of 1. backing the one knob way off, 2. adjusting with the other knob, and then 3. tightening the first knob back against the adjuster, try the following: 1. Back the first knob off ONLY by the amount that you wish to tweak the adjustment – 1/4 turn or 1/8 turn or whatever. 2. Adjust with the other knob until it gets tight.

ALTITUDE HINT: Try to make your final tweaks in altitude so that you are raising the mount from below the pole rather than descending onto your precise altitude. This ensures that the mount is held in place by the adjusting mechanism as well as the locking lever.

CLUTCH KNOBS AND BALANCING

R.A. and Dec. Clutch Knobs

1. What do they do?
The three R.A. and three Dec. CLUTCH KNOBS have the function of connecting the R.A. and Dec. axes to their respective drive worm wheel gears. Their function is progressive, from no tension (axes free to move - as required during correct balancing of the telescope) to a completely "locked up" state.
2. How can you find out what they really do?
As shipped, all *Mach1GTO* mounts have all three R.A. and Dec. CLUTCH KNOBS firmly hand tightened. This will give you a good idea of the maximum tightness (clutch action) that can be achieved by hand effort alone. At this point, you must bear in mind that for optimum performance all three CLUTCH KNOBS on each axis (R.A. or Dec.) should be tightened evenly with the same tension (i.e. all three half tight, all three fully tight, etc.).

In order to feel the effect of the CLUTCH KNOBS, you may wish to assemble your mount with the mounting plate and COUNTERWEIGHT SHAFT. Do not put scope and COUNTERWEIGHTS on at this stage. With the above assembly (with the CLUTCH KNOBS firmly hand tightened - "as shipped"), you can feel the amount of force needed to move each axis by hand. Grab each end of the telescope mounting plate and move it with a backward and forward movement of the Dec. axis. You will feel considerable resistance to this motion. Perform the same operation on the R.A. axis by moving the counterweight shaft backward and forward. With a well-balanced telescope, the above tightness of the clutch knobs will be sufficient for all normal conditions of use.

Now, mount up and balance your telescope so you can "feel" what this resistance in R.A. and Dec. (movement backwards and forwards) is like when you make these motions from the eyepiece end of your telescope as you would during normal use when slewing (pushing) by hand to acquire an astronomical object within the field of view of your finder or scope.

3. How tight can the clutch be and can you do any damage by over-tightening them?
These clutches can be tightened as much as needed. There is no danger of over-tightening. You will see that each clutch knob has a 3/16 hex socket for tightening with an Allen key. Using the provided hex key you can lock up the clutches so that only the worm drives are able to move each axis. You should **NOT** attempt to push your scope by hand against this "locked up" resistance, or undue stress will be placed on the worm wheel, worm gear and bearings. Also note that locked up clutches provide no safety factor for your equipment should you hit the pier!

Most users will never need to use a hex key on their *Mach1GTO*'s clutches, but if you are heavily loaded, if your system is out of balance, or if you are doing critical long exposure astro-photography, you may wish to have the extra clutch tightness. As a general rule, if you have a big scope (6" refractor or 10" SCT) with all the accessories, you will need more clutch tension than a 4" or 5" scope.

4. My clutches don't seem to loosen up the axes as much as my 900 or 1200 mount's clutches when I loosen the knobs. Is this correct?
The *Mach1GTO* uses a different clutch system, and it also uses a different bearing system for the free rotation of the axes. It will feel stiffer than the 900 or 1200 series mounts.
You should also be aware that the clutch knobs on the *Mach1GTO* have spring loaded tips that may still be applying pressure to the clutches, even though the clutch knobs feel loose. Back the clutch knobs off by at least two or three full turns to fully disengage the clutches.

Balancing Your Telescope

For proper operation, the telescope must be adequately balanced along both axes. Note that we say: “adequately balanced.” The mount is quite robust. You do not need to obsess with getting things “precisely balanced!” Start by balancing the tube assembly.

First, Balance the Declination Axis.

1. Position the mount for balancing. Move the R.A. axis so that the COUNTERWEIGHT SHAFT is pointing down. The declination axis assembly will be in the meridian (this is the classic photographic pose for a German Equatorial). Position the Dec. axis so the telescope tube is horizontal and pointing east.
2. Tighten the 3 R.A. axis CLUTCH KNOBS.
3. Loosen the 3 Dec. axis CLUTCH KNOBS (about 2 to 3 full turns) so that the telescope moves freely about the declination axis. NOTE: because of a spring mechanism, you must loosen the knobs past where they begin to feel loose. Be careful because if your telescope is significantly out of balance, it may swing rapidly in the out-of-balance direction!
4. Loosen the tube mounting rings and slide the tube back and forth for balancing. This is best done with the tube in the horizontal position. If you are using a dovetail mounting plate, slightly loosen the hand knobs on the female dovetail receiver plate and slide the male sliding plate (and thus the telescope) to the desired position.
5. The scope is balanced when it stays put (does not move) with the clutches loose and movement back and forth about the declination axis has the same feel in both directions. Be mindful of eyepieces, cameras and other accessories that are yet to be added and compensate accordingly.
6. Re-tighten the telescope mounting rings or mounting plate dovetail clamps!

Second, Balance the Polar Axis

1. Now, tighten the DECLINATION CLUTCH KNOBS and position the mount with the telescope horizontal and the declination axis horizontal. The COUNTERWEIGHT SHAFT is now horizontal with the center of the COUNTERWEIGHTS the same height as the middle of the tube.
2. Loosen the R.A. CLUTCH KNOBS (also about 2 to 3 turns). Again, be careful because if your scope is significantly unbalanced, it may swing rapidly in the out-of-balance direction.
3. Move the COUNTERWEIGHT(S) up or down to achieve the correct balance in R.A. Again, movement back and forth about the R.A. axis should have the same feel in both directions.
4. Re-set the tightness of all 6 CLUTCH KNOBS to the resistance you want making sure that each axis' 3 clutches are evenly tightened. (See section on CLUTCH KNOBS above.)

Try to anticipate any balance problems due to the extra weight of diagonals, heavy eyepieces, finders, solar filters, etc. If the scope moves by itself, when the clutches are loose, then the scope is not balanced adequately. You may want to “tweak” by carefully repeating steps 1 – 5 after everything has been attached to the telescope. Be especially careful loosening the Dec. clutch knobs.

Note: A small amount of imbalance on the East side of the mount is permissible and even desirable for astrophotography and imaging. This allows gravity to keep the drive train fully engaged while tracking throughout the exposure. If you intentionally create this small imbalance, you must remember to re-adjust the balance whenever you flip from one side of the mount to the other. Forgetting to re-adjust can result in a slight see-saw action in tracking that could spoil your next image.

CABLE MANAGEMENT

Introduction to one of the Mach1GTO's most Innovative Features

In years past, there was no such problem as cable management on astronomical equipment. The only wires or cables would have been for the clock drive motor of the RA axis, and maybe one for a drive motor attached to the dec's tangent arm. Today, we have added the cables that accompany film cameras, CCD cameras, autoguiders, multiple dew heaters, motorized focusers, and numerous other electronic accessories. Many modern imaging setups have wires going everywhere, and these wires could be a never ending source of problems and frustrations for the operator. Wires hanging off of cameras can lead to image ruining flexure. Wires can catch and snag as the mount slews, and were especially vulnerable when a German Equatorial Mount was "swapping sides" to point at the other side of the meridian. The problem was that all these wires going to all these different locations had to deal with a mechanical system that was designed to be in motion.

Roland Christen and the design team at Astro-Physics came up with an elegant solution to the "cable nightmare." If cables all around the mount are a problem, then run them through the mount! The idea seems absurdly simple, but it introduced some significant engineering and design challenges, particularly since this mount is portable and the two axes come apart. Those challenges were met with the *Mach1GTO*. There are four places on the *Mach1GTO* where cables can enter or exit the inside of the mount.

1. The first of these is the hub end of the dec axis. Underneath the DECLINATION HUB PLATE on the end of the declination axis are two CABLE CHANNELS. Cables passing through the hub get routed through one of these channels and on to their accessory. This is where imaging cables, dew heater cables and motorized focuser cables are most likely to be routed.
2. The second point of egress is the SIGHT HOLE / CABLE ACCESS COVER on the dec axis. You can run the dec leg of your servo drive's Y-cable out through this opening. It is also a very convenient place from which to feed cables.
3. The third place to run cables in and out is the CABLE ACCESS COVER on the RA axis. This is an especially useful place if you need to do a rough polar alignment each time you set up. It still allows the easy use of the polar scope.
4. Finally, for permanent installations or regular observing spots with marked pier / tripod positions (in other words, observing sites where you don't need the polar scope) the cables can be run out the bottom of the RA axis.

Which of these openings you use will depend on your particular situation. All of the openings and internal cable passages have a two inch diameter clearance that will accommodate a DB15 serial plug with relative ease. It is certainly not required that you run any cables through the mount, but many of you will find this feature useful.

Preparation

Your approach to cable routing will depend on two main factors: the particular cables you need to run and the degree of portability of your system. These factors lead to a couple of questions: Will the telescope's mounting plate remain attached to the mount between observing sessions? Is the mount often removed from the pier / tripod between sessions? Do you need to rough polar align each time you set up or can you set up and always be close enough to not need a polar scope? Or are you permanently mounted? Since everyone's situation will be a bit different, these instructions are more guidelines rather than specific "follow these to the letter or else" instructions.

If it is practical, you may find it most convenient to first set up your mount following the above instructions and get it pretty well polar aligned. The two axes must be assembled to run your cables. You won't do a final drift alignment yet, but you will want to get close. This is especially the case for those of you who are using a polar alignment scope like our PASILL4. You do not want to have the polar scope installed when the cables are being run through the inside of the mount or you might scratch the polar scope's objective. However, as you will see, there is a way to use your polar scope with the cables already in place, though this may not be possible in all cases. Do not have your telescope or mounting plate attached yet.

Remove the DECLINATION HUB PLATE off of the DECLINATION AXIS HUB by removing the six 1/4-20 x 3/4 FLAT HEAD SOCKET CAP SCREWS around its perimeter. Remove the polar scope from the RA axis if you are using one. Finally, remove the POLAR SCOPE ADAPTER (with POLAR SCOPE CAP) and raise the two CABLE ACCESS COVERS (one on each axis) to the open position. You are now ready to put in your cables. Note: starting with mounts that began shipping in April, 2007, the POLAR SCOPE ADAPTER is a bit larger and has a knurled grip for easier removal.

Cable Installation – the First Time

Cables can be inserted either from the top (through the DECLINATION AXIS HUB) or bottom (through the polar scope end of the RA axis), but the simplest way will usually be to insert the cables through the SIGHT HOLE / CABLE ACCESS COVER on the declination axis. The easiest trick for inserting the cables, if you will be routing cables out through the DECLINATION AXIS HUB (as is likely), is to turn the RA axis so the COUNTERWEIGHT SHAFT ADAPTER is pointing up and south and let gravity do the work. Always start by running the cables with the largest connectors first. Insert the telescope end of the cable into the SIGHT HOLE / CABLE ACCESS COVER on the dec axis and guide it “down” and out the DECLINATION AXIS HUB. Insert the opposite end in the same opening and guide it either out the RA’s CABLE ACCESS COVER or out the bottom of the RA axis. If you are routing out the bottom of the RA axis to help you guide the cable end out the access hole.

When all the necessary cables have been run through the mount, turn the RA axis so that the mount is in its normal position with the COUNTERWEIGHT SHAFT ADAPTER pointing down and north. Adjust the amount



of each cable that you will need sticking out through the DECLINATION AXIS HUB to adequately reach its electronic device. When determining the length, be sure to run the cable through the CABLE CHANNEL and allow enough slack so that there will be no tension on the cable’s plug. Make sure you allow for focuser travel. Don’t allow too much slack, however, or you will defeat the whole purpose of hiding the cables inside the mount. Be sure that you route each cable through the appropriate CABLE CHANNEL side for the side of the telescope where it will plug in. Also, keep in mind any other places where you may wish to tie your cables like on the end of a mounting plate. Cables for CCD cameras should be tied off to the focuser or the very back of the mounting plate.

Once the cables are routed through the mount, and you have the proper amount sticking out the top of the DECLINATION AXIS HUB, you are ready to replace the DECLINATION HUB PLATE. Be sure that the cables are seated well in the two CABLE CHANNELS and that they are not being pinched by the plate. Put in two screws, one each on opposite sides of the plate and snug them down. Re-check that none of the cables have been pinched and then tighten the two screws firmly. If you are using the FP1800, the RP900 or the Q4047 (with DOVE08) as your telescope mounting plate, install it now using the four provided screws in the remaining four holes. If you will be using one of the other telescope mounting plates (FP1500, DOVE15, DOVELM2 or DOVELM162), first install the remaining four screws from the DECLINATION HUB PLATE, and then install the mounting plate with the correct fasteners that were provided.

Where the cables emerge (RA CABLE ACCESS HOLE or bottom of RA axis), make sure that nothing will be hanging or pulling on any of the cables. You may wish to bundle the cables together and tie them off to a tripod leg or pier strut to eliminate potential tripping hazards. Run them carefully to wherever they will be plugged in (laptop, heater controller etc.) and try to avoid creating tripping hazards. If you have run the cables out the RA’s CABLE ACCESS HOLE, replace the POLAR SCOPE ADAPTER and POLAR SCOPE CAP. Do NOT over-tighten the POLAR SCOPE ADAPTER. You can also partially close the SIGHT HOLE / CABLE ACCESS COVER on the dec axis and the CABLE ACCESS COVER on the RA axis at this time. They can’t be closed all the way with cables routed through them but they can be closed enough to keep most dirt and dust out.

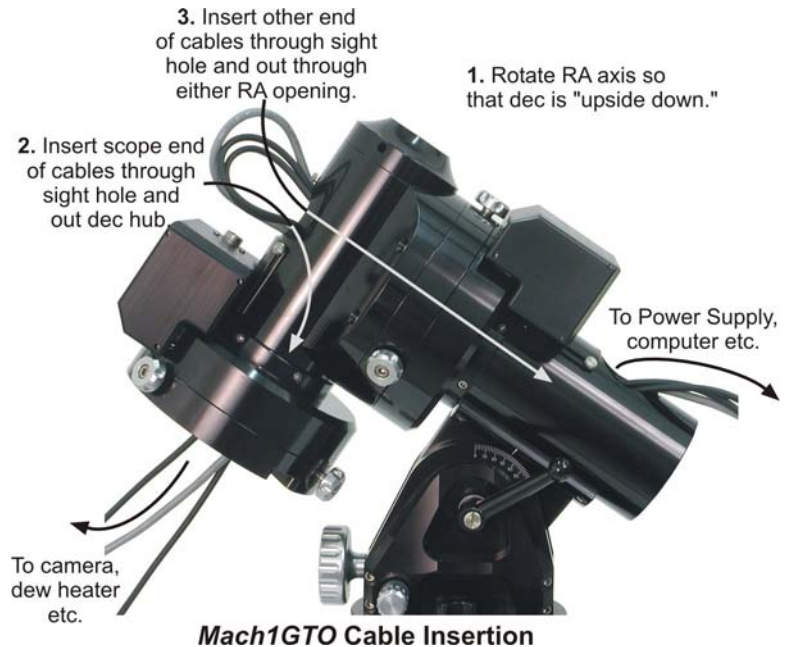

of each cable that you will need sticking out through the DECLINATION AXIS HUB to adequately reach its electronic device. When determining the length, be sure to run the cable through the CABLE CHANNEL and allow enough slack so that there will be no tension on the cable’s plug. Make sure you allow for focuser travel. Don’t allow too much slack, however, or you will defeat the whole purpose of hiding the cables inside the mount. Be sure that you route each cable through the appropriate CABLE CHANNEL side for the side of the telescope where it will plug in. Also, keep in mind any other places where you may wish to tie your cables like on the end of a mounting plate. Cables for CCD cameras should be tied off to the focuser or the very back of the mounting plate.

Once the cables are routed through the mount, and you have the proper amount sticking out the top of the DECLINATION AXIS HUB, you are ready to replace the DECLINATION HUB PLATE. Be sure that the cables are seated well in the two CABLE CHANNELS and that they are not being pinched by the plate. Put in two screws, one each on opposite sides of the plate and snug them down. Re-check

that none of the cables have been pinched and then tighten the two screws firmly. If you are using the FP1800, the RP900 or the Q4047 (with DOVE08) as your telescope mounting plate, install it now using the four provided screws in the remaining four holes. If you will be using one of the other telescope mounting plates (FP1500, DOVE15, DOVELM2 or DOVELM162), first install the remaining four screws from the DECLINATION HUB PLATE, and then install the mounting plate with the correct fasteners that were provided.

Where the cables emerge (RA CABLE ACCESS HOLE or bottom of RA axis), make sure that nothing will be hanging or pulling on any of the cables. You may wish to bundle the cables together and tie them off to a tripod leg or pier strut to eliminate potential tripping hazards. Run them carefully to wherever they will be plugged in (laptop, heater controller etc.) and try to avoid creating tripping hazards. If you have run the cables out the RA’s CABLE ACCESS HOLE, replace the POLAR SCOPE ADAPTER and POLAR SCOPE CAP. Do NOT over-tighten the POLAR SCOPE ADAPTER. You can also partially close the SIGHT HOLE / CABLE ACCESS COVER on the dec axis and the CABLE ACCESS COVER on the RA axis at this time. They can’t be closed all the way with cables routed through them but they can be closed enough to keep most dirt and dust out.

Disassembly and Subsequent Setups and Polar Alignments

Once you have gone to all this effort, you won’t want to undo everything for relatively simple tear-down and set-up situations. And you won’t have to! The degree to which you must disassemble the cabling depends on the degree to which you must break down the mount. If you need to disassemble the mount for airline travel, you will unfortunately need to undo everything. If you simply move your entire assembly in and out of the garage on its pier or tripod, you will hardly need to take anything apart. Most of us are somewhere in between. Disassembly steps are basically the reverse of the installation steps above and really don’t

need further elaboration. The main point is that you will want to avoid complete removal of the cables that involves taking off the DECLINATION HUB PLATE if that is possible for your situation.

The real question is: how can subsequent setups be done easily, and how can a person polar align with all those cables in there? Fortunately there are two easy solutions. First, if you regularly need to use your polar scope and you are only running a couple of cables through the mount, just make sure that your cables were run out the RA's CABLE ACCESS HOLE. If you use this feature, you can insert and use the polar scope without any problem. (You may need to tug lightly at a cable to get it out of the line of sight when aligning.) The cables can simply be left in place and wrapped around the mount for most transport and storage situations. You simply need to take care not to pinch the cables anywhere or to strike a connector on the exterior surfaces of the mount, which could cause a scratch. Then, just set up the mount with the cables already in place.

But what about polar alignment if the cables have been run out the bottom of the RA axis or if there are very many cables? Simple! Set your mount up on its tripod or pier, but don't tie off or hook up any of the cables from the bottom of the RA axis yet. Now, open the SIGHT HOLE / CABLE ACCESS COVER on the declination axis. Push the cables up from the bottom of the RA axis with one hand and hook them with a finger through the sight hole. Now pull the bottom part of the cabling out through the hole and hang the cables out of the way. Insert your POLAR SCOPE ADAPTER to rough polar align (don't over-tighten), and then put in a polar scope to get a good polar alignment. When you are as close as you can get, pull off the polar scope and adapter, and reinsert your cables through the SIGHT HOLE / CABLE ACCESS COVER. You are now ready to tie them off, plug them in and go!

A Note on the Mount's Servo "Y" Cable

The "Y" cable that connects your GTOCP3 control box to the servo motor gearboxes can be run either inside or outside the mount. The *Mach1GTO* doesn't really have anything that will catch the cables, but you still may want to run them inside. This is one cable that will not be run out through the DECLINATION AXIS HUB. To insert the "Y" cable, put the control box end into the SIGHT HOLE / CABLE ACCESS COVER on the declination axis. Run it out through the RA's CABLE ACCESS COVER, and pull the shorter RA leg of the cable all the way through. (Again, if the POLAR SCOPE ADAPTER is removed, you can easily guide the control box plug out the CABLE ACCESS COVER of the RA axis.) Only the declination portion will be left inside the mount. Connect all three plugs. When you remove this cable, don't reverse the procedure; simply pull the declination leg on out through the RA's CABLE ACCESS COVER.

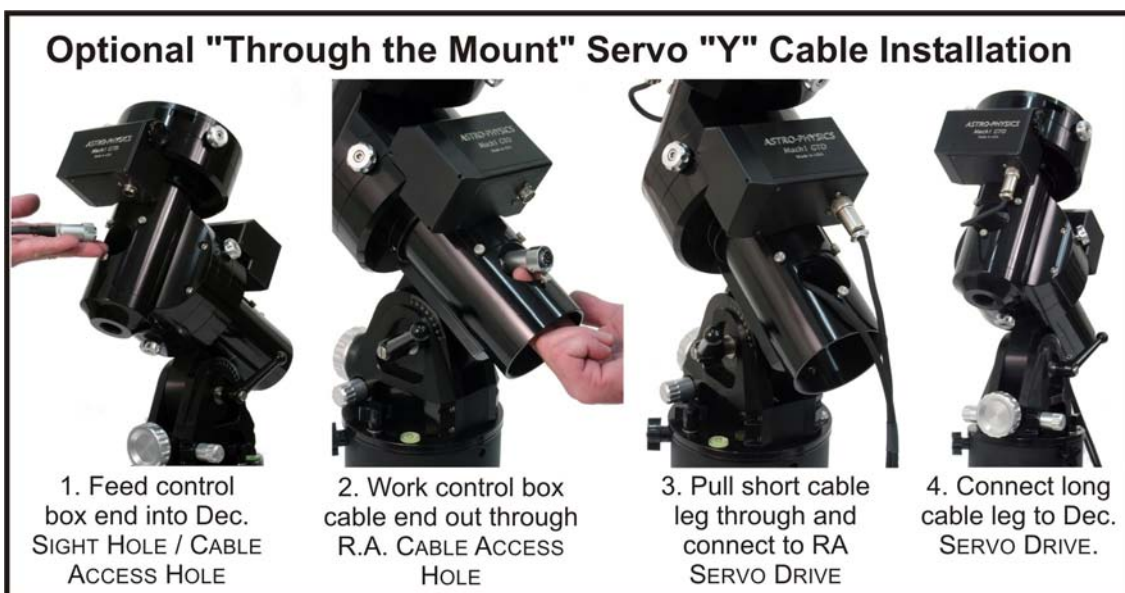

A Few More Hints and Tricks

- If you need to remove a cable completely from the mount, mark the point where it emerges from the CABLE CHANNEL in the DECLINATION ACCESS HUB. Wrapping the cable at that point with a small piece of colored electrical tape works well. That way you won't need to re-measure to position the cable properly.
- It is often helpful to bundle some of your cables.
- Always tie off cables for CCD cameras to the focuser so that the weight of the cables doesn't cause movement (flexure) in the imaging system over a long exposure.

Please feel free to contribute hints and tricks of your own for future editions of this manual. At Astro-Physics, we know that our customers can be downright brilliant! E-mail your suggestions to support@astro-physics.com.

SERVO MOTOR DRIVE

The Servo Motor Drive system on the *Mach1GTO* uses the same motors, the same GTOCP3 control box and the same keypad as its bigger siblings, the 900GTO and 1200GTO. The gear train is just as heavy-duty, and the worm gears are massive and incredibly precise. This is an extremely robust system for a mount of this size, but since the focus of the *Mach1GTO*'s design was on the serious observer and imager, we felt that it was well worth it.

GTO Control Box – GTOCP3

The GTO control box contains all of the circuitry to drive the two servo motors and the logic required to navigate the sky. It will be operational and track at the sidereal rate when connected to both motors of the mount and a power source. In order to control the movement of the mount, you will need to connect at least one of these:

- GTO Keypad.
- Computer with PulseGuide by Sirius Imaging. The CD for this program is included with the mount. For the most updated version of the software, check out the website www.pulseguide.com.
- Computer with a planetarium program such as Software Bisque's *TheSky™*, Imaginova's *Starry Night™*, Nova Astronomics' *The Earth-Centered Universe (ECU)* version 3.1 or later, and Chris Marriot's *Sky Map Pro 6* or any ASCOM compatible telescope software (all purchased separately).

The *Mach1GTO*'s GTO Servo Control Box comes with a Control Box Adapter for direct mounting on your pier or tripod as well as handy pouch for hanging from a knob on the base of your *Mach1GTO* mount. Please remember that this box contains advanced electronics and must be treated with the same care given to other fine equipment. You can see that the unit is built to be rugged, however it is not indestructible.



Lead-Free Electronics

Starting in 2006, we began phasing in lead-free electronics for all of our mounts. In the first phase, all *GTO* mounts (and other electronics) shipped to customers in the European Union were built with lead-free electronic components due to RoHS regulations that went into effect on July 1, 2006. As of mid 2007, all of our electronics adhere to this safer and more environmentally responsible standard. All functions and capabilities of the Servo System were maintained with the lead-free components.

R.A. and Dec. Cable Connections

A “Y” cable with 10-pin connectors is included with your mount. Attach the connector from which the two cables emerge to the GTO Control Panel. Attach the short part of the “Y” cable to the R.A. motor housing and the long part of the cable to the Dec motor housing. Lock all connectors. Refer to the section above for further information about positioning the cables.

12V Connector

Place the DC power cord (included with your mount) into the DC power plug outlet marked 12V on the GTO Control Panel and lock in place. Plug the cigarette lighter plug end of the cord into your power source. The acceptable voltage range is 11.5

to 16. Suggested power sources include: portable rechargeable battery pack, auto or marine battery, or power supply (filtered and regulated) for 110 volts AC input with a minimum output of 5 amps at 12V DC. We highly recommend our 13.8 volt, 5 amp power supply (PS138V5A) for the Mach1GTO.

There is no on-off switch on the servo. We recommend that you plug the power cable into the servo box after the keypad controller. To turn the unit off, simply disconnect the power cable.

Considerations for observatory installations: We suggest that you disconnect your GTO Control Box from 110V and any other device (CCD camera, computer, etc) when you are not using your mount so that if your observatory experiences a power surge or lightning strike, your mount electronics will not be damaged. If you operate your mount remotely, you will have to leave your power cable connected just as you do for the rest of your electronic equipment. You may want to consider surge protectors or other protective measures to protect from voltage spikes. A disconnect relay to remove power from both the 12-volt and ground wire is highly recommended in this situation.

POWER Indicator Light

This LED will remain illuminated when your power source has sufficient output to drive the motors. If the voltage falls below 10.5 volts, the power light will go out and the motors will stop. The keypad controller will not function properly.

If the LED turns yellow, this means that your motors are overloaded, probably due to an unbalanced load on your mount. Refer to the troubleshooting section of the manual for the solution.

KEYPAD Connector

Attach the 5-pin male connector of the keypad controller and lock in place (push in the knurled ring then turn).

RS-232 Connectors

These serial port connections are used to connect your mount to your PC computer. Beginning in December 2008, we began providing a 15' straight-through (non-crossing) serial cable with a 9-pin (DB9) male connector to interface with the GTO Control Panel. The panel is equipped with the locking posts to secure the cable firmly onto the control box. If you purchase a serial cable that does not have a 9-pin connector, you can use a gender changer or adapter to convert it. **Please note:** *the use of "crossing," "reversing," "null," or "null modem" cables is a frequent source of failure and frustration. Make sure that your serial cable is wired straight-through!*

When you are controlling the position of the mount with a computer program such as *PulseGuide™*, Software Bisque's *TheSky™*, or Imaginova's *Starry Night™*, the microprocessor chip located in the servo drive box will send continual RA and Dec. coordinate data via the cable connections to your computer. When you use the software to give instruction to slew to a new object, the commands (RA and Dec. coordinates) are sent to the mount.

We provide two serial port connections on the mount so that you can use two software programs simultaneously (in addition to any auto-guider software that may be sending signals to the mount through the Auto-guider Connector). For instance, you can use *PulseGuide* for advanced mount control, while using *TheSky* as a planetarium program. The telescope control functions of *TheSky* are more limited so using both in a remote application is advantageous. Since the mount will update the RA and Dec coordinates simultaneously, both programs are continually updated with the data from the mount. You can watch the screen display of *TheSky* to see where your telescope is pointing as it slews. This is most effective if you have a reasonably fast computer with plenty of RAM. If you try this with a 100MHz processor and only 32 MB of RAM, the response time will be slow since both programs must be continuously updated with position data.

You must have two serial ports available on your computer to take advantage of this feature. If you use a laptop or a newer desktop computer, you may need to purchase a USB to Serial Adapter. Starting in the spring of 2008, Astro-Physics began offering single port and four port units made by Keyspan™ that we have found to work quite well on our own equipment. The serial ports on the GTOCP3 control box will even allow remote operation of your mount, a handy feature for catching those winter pretties from the warmth of the house. We have tested setups using an Ethernet based USB Server (also from Keyspan) coupled to the four port Keyspan USB to Serial Converter. The USB Server provided four USB ports, one of which was used by the four port USB to Serial Adapter, leaving 3 available USB and four available Serial ports at the mount. The computer was connected to everything via a single RJ45 Ethernet cable. For a more detailed discussion, go to our website: www.astro-physics.com. We also recommend that you go to the Yahoo ap-gto user's group (access it through our website) and type "pcmcia" "serial" or "usb" into the search box. Also, be sure to keep an eye on the "What's New?" pages of the website for further developments in this area.

FOCUS Connector

Attach the 3.5mm phono plug connector of your JMI Motofocus or other electric focuser (optional accessories) here. Refer to the section regarding focus adjustment in the GTO Keypad Manual for instructions on using the keypad controller to adjust focus.

RETICLE Connector

If you wish to use the illuminator cable for our polar alignment scope or plug-in-type guiding eyepiece with an illuminated reticle (available from several manufacturers), insert the 3.5mm phono plug into this connector for power. Reticle brightness can be adjusted with the hand control. Refer to the section pertaining to reticle illuminator adjustment in the GTO Keypad manual for further information.

AUTOGUIDER Connector

This connector interfaces with the RJ-11-6 modular jack of an autoguider cable, purchased separately or as part of a CCD Imaging Camera or Autoguider. The autoguider will be functional and ready to go as soon as you plug it in. Please refer to the appropriate manual from the manufacturer for operation of the autoguider.

+6V Connector

This 6-volt output accepts 3.5mm phone plugs. It's original purpose was to power the Pentax 6x7 camera directly from the mount. Its most common usage today is to power the StarGPS. It has also been used to power BlueTooth units for wireless connection to the mount's COM ports. Center is positive. It will supply up to 200mA of current. Be sure of your device's power requirements and polarity before attaching!

N and S Switch

Select northern (N) or southern (S) hemisphere as needed. When you slide the switch to the opposite position, the tracking direction of the drive will reverse. The power cord must be removed and re-attached to make this work.

Drainage Holes

Two holes are drilled into the lower portion of the bottom of the control box. These holes allow excess moisture to drain from your control box, particularly useful on dewy nights. Please do not plug these holes.

Pre-loaded PEMPro Curve

Your mount was tested at our production facility with a special version of PEMPro Periodic Error Management Software. After ensuring that the mount's unccorrected periodic error is within our specifications of 7 arc-seconds peak-to-peak, we generate a unique optimized PE curve for your specific mount, and then save the corresponding PE correction curve to the GTOCP3 control box for you to use. By turning PE on from the keypad, you can take advantage of this PE curve the very first time you use your mount. This PE curve should remain valid for several months as your gears "run in" and will probably suffice for many mount owners. Instructions for turning the PEM on in the keypad's "Tools" menu are found in the keypad manual.

If you decide to purchase PEMPro in the future, it is suggested that you save the existing curve to your computer before overwriting it in the control box with a new curve, just in case you do something wrong in your first attempt at a PEMPro run. That way, you can re-load the old data back to your control box if needed.

GTO KEYPAD CONTROLLER OPERATION

Please refer to the separate manual for the GTO Keypad for complete instructions.

SLEWING YOUR MOUNT IN BELOW FREEZING TEMPERATURES

Notes from Roland during a very cold spell in January 2005:

“There are several potential problems when slewing your mount in below freezing temperatures. The symptoms are a wavering or chattering sound from the motors, a slowing down of the slewing with a sudden jolting stop at the end of the slew, and in the worst case, a continuous running of the motors and loss of control. I have seen similar things on my own mounts when the temperature dips below zero F. There are three things that you can look at to alleviate the problem.

First, in cold weather it takes a very much larger amount of power to slew the motors than it does in the summer (see tests I ran below). This extra current drain can cause a voltage drop in the power cord running from the supply to the servo. If you have a long distance between the supply and servo, use a heavy wire to minimize the voltage drop. If the power drops below about 11 volts at the servo terminal, the internal computer chips may reset with subsequent loss of control of the motors. If your supply is marginal, it may also not produce the voltage necessary for proper operation during slews. It is a good idea to limit the slew speed to 600x during real cold weather to reduce the power demand from the supply.

Second, it is very important to have the worm mesh not set overly tight. One symptom of overly tight worm is a chattering sound as the motors try to slew at 1200x or even as low as 600x. You can check to see if the worm turns easily with your finger by removing the motor covers and removing the large spur gear to get access to the worm end. Try turning it by hand. If it does not easily turn, then the motor will also have a difficult time turning it. Check in our technical section of the AP web site on how to set the worm mesh. In real cold weather, well below zero F, it might also be a good idea to lubricate each of the spur gears and their sleeve bearings with a light machine oil. When warmer weather returns, this can be replaced with a light grease, Lubriplate 105, which will reduce the wear factor in warm temperatures.

Third, under very extreme temperature conditions below -20F, it may be necessary to replace the grease on the worm wheel teeth with a lighter material. The mounts use a special formulation of Lubriplate 105 with a damping grease added. This combination is ideal for low wear since the damping grease portion allows the grease to stay on the teeth and not get wiped off by the motion of the worm. Although this combination works well even at temperatures below zero, it does get more viscous in really cold conditions. We have tried straight low temperature greases that work to -80F, and in each case, the worm gears get abraded very quickly. Using no grease at all is also not recommended for a GoTo system that slews at high speeds. The wear on the worm and wheel teeth is extremely high and can develop very high periodic error after a short time due to scratches and high spots that develop on the gear teeth. At this time we have no solution to ultra-low temperatures.

Last night it was -8 F here, and I tested several of our mounts in the observatory. Two are very old, from the original batch, and one is brand new. All worked well at 600x but showed signs of laboring at 1200x slewing. I use a 12-volt marine battery to power them. I replaced the marine battery with a variable power supply that I varied from 12 volts to 18 volts. At 12 volts when both motors were slewing at 1200x, the power draw was in excess of 8 amps (in summer this is around 2.5 amps). The motors were laboring and not running smoothly at full speed. I turned up the voltage to 15 volts, and the current draw dropped to around 5-6 amps. The motors worked smoothly at 1200x with no hesitation at that voltage level. I would recommend for cold weather work to get a supply that can deliver 15 - 16 volts at a rated current capacity of 10 amps. Higher than that is not necessary. Above 18 volts is not recommended.”

It is possible that these recommendations may change over time due to new lubricating products or upgrades to the keypad program that will allow slewing at 300x (under development as of this writing). Please refer to the Technical Support section of our website for the latest recommendations.

MOUNT CARE, CLEANING AND MAINTENANCE

Like any fine piece of equipment, your mount's longevity and performance are directly correlated with the quality of the care that you give it. Handle it with respect, keep it as clean and dry as is practical, and perform a few minor maintenance tasks, and your *Mach1GTO* will give you many years of trouble-free service.

Care

Although we build it to be rugged enough for field use, your *Mach1GTO* is a precision instrument with very accurate worm and wheel adjustments. Please be careful if you place the mount on a flat surface, i.e. the ground or trunk of your car. The gear alignment may be affected if the R.A. and Dec. motor/gear box assemblies sustain undue lateral force. This is true of

any fine instrument. We suggest that you transport and store the mount in a case or in a well-padded box. ALWAYS remove the mount from your pier or tripod before moving it or transporting it. More damage can be done in a few careless seconds in transit than in many hours of normal operation.

Try to keep your mount protected from dust and moisture when not in use. In warm, humid weather, be aware of the dew that may have formed on the mount while in the field and allow the mount to dry out before packing it away for storage once you get home. On the other hand, if it is cold and dry outside, keep the mount packed up when you bring it into the house until it reaches room temperature to avoid “fogging it up.” (The same advice applies to telescopes, eyepieces and other equipment in your Astro-arsenal.)

Cleaning and Touch-up

Wipe your mount clean with a soft dry cloth. If needed, you can use a damp cloth or a cloth that has been sprayed with a mild, non-abrasive cleaner (window or all purpose cleaner – no bleach). Do not spray cleaners directly onto your mount. If you use a cleaning product, follow with a damp cloth to remove the chemicals from the mount.

The anodized surface of your mount is relatively maintenance free and should not require frequent touch up like some painted surfaces.

Mount Maintenance

Under normal operating conditions, minimal maintenance is required. If the R.A. and Dec. axes are attached together for a long time in outside conditions (i.e. in a permanent observatory) then the mating surfaces should be lightly oiled or greased - if you expect to get them apart again after 10 years.

Jostling and vibrations associated with transport to and from observing sites have had the effect of causing screws and fasteners to work their way loose over time. We have worked very hard in both the design and assembly of our mounts to alleviate this problem, but it is still a good idea to periodically (once or twice a year) inspect and if necessary re-tighten any easily accessible fasteners. Additional maintenance information can be found below in the troubleshooting section and in the Technical Support Section of our website.

ADDITIONAL TIPS AND SUPPORT

For additional information regarding the *Mach1GTO*, refer to the Technical Support Section of our website. We also encourage you to participate in the ap-gto user group. The members of this group are very knowledgeable about the operation of their mounts, CCD imaging and other related issues. The staff of Astro-Physics also participates and you will find a wealth of information in the archives. To find the group, link from User Groups in our website’s sidebar.

We encourage you to submit your technical support questions directly to Astro-Physics by phone or e-mail: support@astro-physics.com.

TROUBLESHOOTING

Additional troubleshooting questions are in the GTO Keypad manual. Some of the issues discussed in the keypad manual relate to mount communication issues whether you use the keypad or control the mount with a planetarium program or PulseGuide. Please refer to them.

The LED on the GTO Control Box changes from red to yellow and the motors stop or go out completely

1. The motors are overloaded, probably due to a grossly unbalanced load on your mount. See the sections on clutches and balancing earlier, and the additional entry on balancing toward the end of this “Troubleshooting” section.

Rebalance your telescope, and then press one of the N-S-E-W buttons to reset the keypad. Re-enter the last object on your keypad and the scope will slew to the correct position. Even though your motors had stopped, the logic in the control box retained the scope position in memory. As long as you didn’t change the pointing position of the scope, you are still calibrated.

If the scope was moved during re-balancing, simply enter a nearby bright star on the hand controller, press GOTO and allow the mount to finish slewing. You can then move the scope manually or with the N-S-E-W buttons to center the star in the eyepiece, and press the #9 RECAL button. This will recalibrate the mount.

Additional explanation: The GTO drive circuit includes logic for overload protection to prevent burning out the expensive servomotors in case of severe overload on the two axes. The primary cause is a severely unbalanced load in R.A. If the extra load opposes the motor rotation, the motor must work harder to track at the sidereal rate and the current will rise to high levels. If the current exceeds the trip point for more than a minute, the logic will shut the motor off and tracking stops. It typically takes about 4 lb. of unbalance to trip the overload, but a very heavy load of scopes, accessories and counterweights on the mount can decrease this unbalance threshold.

2. The voltage of your battery has probably gone below 10.5 volts.
3. The current rating of your AC-DC power supply is too low.

Additional explanation: During slewing, the two motors draw up to 3 amps from a 12 volt source. This may increase when the temperature approaches freezing or below. It is recommended that your supply be rated at 5 amps, 12 volts DC minimum (18 volts max.). If you also power other equipment (CCD cameras, dew heaters, etc.) from the same source, you will need a supply capable of up to 10 amps. The more equipment you have, the more current capability you will need. For portable applications, we recommend a heavy-duty marine battery designed for deep discharge applications. The most common problems are due to inadequate power supply.

The keypad reset (or locked up) when I plugged my CCD camera, PC (or other equipment) into the same battery as the GTO mount was using. The battery has a meter, which shows 12V.

The meter is reading an average and will not show dips. Gel cells have internal resistance, which will cause voltage drop when the load changes. When you connect an additional CCD camera and PC the load will drop below 9 volts and the keypad will reset or it may affect the GTO circuit itself and cause the keypad to lock up.

We recommend that you use a large marine battery that is not a gel cell and hook everything up to it before calibrating the GTO. Or, better yet, put the other equipment on a separate battery.

What is the maximum voltage that I can use to power the servo drive?

The servo drive of the *Mach1GTO*, 900GTO and 1200GTO will withstand up to 24 volts without any sort of damage to the internal electronics, according to our engineer. However, above about 17 volts, the motors may become a bit jittery because of the higher gain with this much voltage. The system works very well with 15 - 16 volts. The *Mach1GTO* should work very smoothly at 12 volts.

For polar alignment, I am using declination drift technique with stars on east & south. Now, I do not see any drifts in declination on both sites (E & S), so the mount should be properly aligned. However, I have still small drift in RA which looks like the RA motor is a bit faster than earth rotation. This drift is something like 1.5 arcsec during 1 minute or so and is accumulated over time, so it doesn't look like periodic error.

The sidereal tracking rate is exact in the mount (it is crystal controlled and checked here for accuracy). However, the stars do not move at exactly the sidereal rate everywhere in the sky. The only place they move at that rate is straight overhead. As soon as you depart from that point in the sky, the stars will be moving more slowly, especially as you approach the horizons. Thus, it looks like the mount is moving slightly faster than the sidereal rate. Just because you have done a classic drift alignment, does not mean that the stars will now be moving at the sidereal rate everywhere in the sky.

In order to increase the area of sky from the zenith that will give you fairly good tracking, you will need to offset the polar axis by a small amount. The amount will depend on what your latitude is. The other approach is to vary the tracking rate for different parts of the sky. Ray Gralak's Pulse Guide will allow you to dial in an exact tracking rate for any part of the sky.

Initially, the mount was working fine. Then, suddenly the mount stopped tracking altogether !

Chances are that the motor was turning properly and driving the worm gear, but that your clutches might have been loose and therefore the scope was not following the motion of the worm gear. The fact that the high slew rate did move the scope does not change this, because Roland has seen this himself where the tracking rate did not overcome the slipping clutches but the slew rate did.

If you are unsure of the motion of the motor, just remove the motor cover plate and look inside. You will see the motor turning. Sometimes when you have the clutches loosely engaged and the counterweights are somewhat out of balance, being heavy in the east, then the clutches might slip at the slow sidereal rate.

In any case, just to set your mind at ease, simply remove the motor cover next time something like this happens and look at the motor shaft. If the motor is not turning, you will have some kind of electrical problem. If it is turning, then it is mechanical.

The motors sound louder and more labored in cold weather.

As the temperature drops, we recommend that you reduce your slewing speed to the slowest slew rate. The cold causes the lubricants to get stiff in the gearboxes. This can make the high-speed gears resonate and sound screechy. Lowering the slew speed in winter will eliminate this. You might also want to add a drop or two of light machine oil to the center posts of the individual gears. Just remove the cover on the gearbox and add the oil drops. The noise is nothing to worry about. Refer to the section of this manual entitled: Slewing Your Mount in Below Freezing Temperatures.

My RA motor has failed, and I need to restore tracking immediately!

Another innovative feature of the Mach1GTO is that the declination and right ascension servo motor/gearboxes are interchangeable. In the extremely rare chance that your RA drive would fail in the field (at a star party in the middle of nowhere under perfect skies according to Murphy's Law), you can simply swap the two motor/gearboxes and still have the mount's tracking ability. Please note that while the declination motor/gearbox box is on the RA axis, you may have a little more periodic error than you are used to, since the fine tuning was done on the RA's original motor/gearbox. Also, since you will be using a different worm gear, your PEM will be different. For imaging, you may need to retrain your PEM. For visual observing, simply turn PEM off while using the declination motor/gearbox on the RA axis.

To remove a motor/gearbox, first separate the two axes, and then remove the four small screws on the box that hold the cover with the servo cable connector, and pull the cover off to the side. Its wires will remain attached to the motor. Next, carefully unscrew the two shoulder bolts that hold the motor/gearbox to the axis. Note that there is a spring exerting pressure against these two shoulder bolts, and take note of the spring's position against the shoulder bolts. When they come loose, the spring will push them over. That is fine; don't try to completely remove the bolts. The motor/gearbox will now separate from the axis. To re-install a motor/gearbox, carefully set the box into position making sure that the worm gear settles into the teeth of the worm wheel. Put the two shoulder bolts in place, but only snug down at this point. Make sure that the spring is properly positioned below the ridge in each shoulder bolt. Gently rock the motor/gearbox back and forth, and then center the box in its range of motion. Now fully tighten the shoulder bolts, starting with the bolt on the left. Finally, replace the cover with the four screws and you're ready to go.

There is a detailed instruction sheet entitled "Remeshing the Worm Gear and Wheel" at the end of this manual that will help you get your gear mesh just right. As more detailed information from real life experience becomes available, it will be posted in the Technical Support Section of our website.

My GTOCP3 Control Box does not appear to be working properly. Can I use the control box from my other Astro-Physics mount with my Mach1GTO?

The answer depends on which model your other Astro-Physics mount is. The GTOCP3 from your Mach1GTO can be interchanged with the GTOCP2 or GTOCP3 from a 900GTO or a 1200GTO mount. The interchange works in either direction: the Mach1GTO can use the 900GTO or 1200GTO's control box, and the 900GTO or 1200GTO can use the GTOCP3 from the Mach1GTO.

A GTOCP1 cannot be used as it does not have the correct servo cable connection. **DO NOT** use the control box from a 400GTO, a 600EGTO, a 3600GTO or from a mount purchased from an OEM partner that uses our GTO system.

As a final note, if you "borrow" another control box for your mount, you must disable the PEM since the PE curve in the borrowed box will be for a different mount. You can always record a new PEM data set if you wish, and there is no reason to preserve the PEM data set in the borrowed box since it will no longer be valid. Any time that you use a different control box on a mount, the PEM data becomes out of phase and will need to be redone. This applies to both the borrowing mount and the lending mount. It is something to consider before trading control boxes, especially if you have achieved a particularly good PEM result with the mount that is to be the "lender."

I am concerned about achieving good balance in the system. My clutches don't seem to loosen up the axes as much as my 900 or 1200 mount's clutches when I loosen the knobs. Is this correct?

The Mach1GTO uses a different clutch system, and it also uses a different bearing system for the free rotation of the axes. It will feel stiffer than the 900 or 1200 series mounts, even with the clutches fully disengaged.

You should also be aware that the clutch knobs on the Mach1GTO have spring loaded tips that may still be applying pressure to the clutches, even though the clutch knobs feel loose. Back the clutch knobs off by at least three full turns to fully disengage the clutches. Then swing the axis back and forth a time or two before trying to actually measure and adjust the balance.

There is really no need to balance the Mach1GTO to any high degree. The motors are quite strong and can handle well over a pound of imbalance in the load. When moving either axis back and forth by hand, even with the clutches not fully loosened, it is quite easy to feel as little as a few ounces of difference.

If you really need to balance for some reason, you can use a small fisherman's scale to pull the axis in one direction, and then the other. When the pull is equal, the axis is basically balanced. Another method is to use an ammeter to measure the current draw. Use the opposing direction buttons at 64x and observe the current being drawn. A balanced load will result in equal current draw in either direction for each axis.

The declination axis does not appear to be moving properly. How can I check it?

Please refer to the appendix for the instruction sheet: "Characterizing the Dec Axis Motions," which explains how to use Maxim DL software to characterize your mount's performance.

If any problems occur, please don't hesitate to contact Astro-Physics for assistance.

CHARACTERIZING THE DEC AXIS MOTIONS

These instructions explain how to use Maxim DL software as a tool for characterizing any problems with the Declination axis movements of your mount. However, Ray Gralak's PulseGuide software offers an easier and more extensive evaluation procedure. PulseGuide is available as a free download through our website.

Step 1

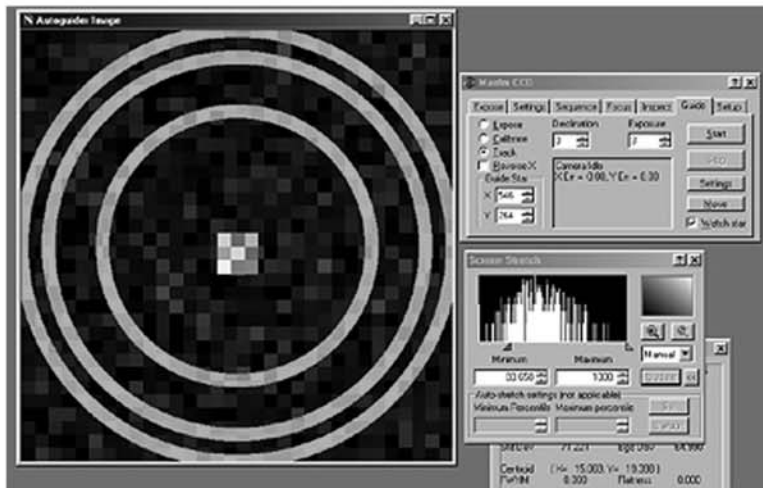

Acquire a reasonably bright guide star and begin guiding in RA only - turn off Dec guiding (note X and Y are switched on the Maxim parameter page, as of v3.07). Use a 1 second or faster refresh rate so you can see the motion of the guide star as you begin to move it around. Magnify the screen to 1600x and place the cursor in the middle as shown. Check to make sure that the mount is guiding adequately in RA, and that the guide star is not bouncing around due to poor seeing. Best results will be achieved when the RA guiding is 0.5 pixels average in RA.

Step 2

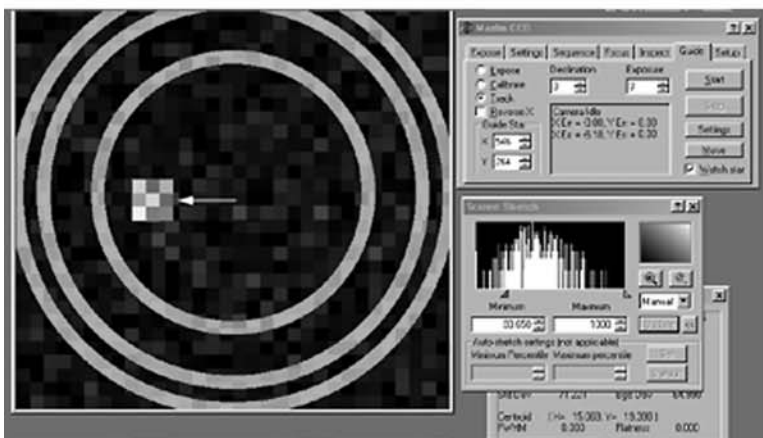

Put the keypad button rate at 0.5x. Press the keypad North button until the guide star has moved approximately 6 pixels from the center. Now press the South button in very short pulses and note which direction the star moves. It should move back toward the middle after a few button presses. It might move slightly up or down, or it might continue to move further away from the middle, or any combination. Please note exactly how far, and in which direction, the guide star moves (pixel position is displayed in the guide box at right in Maxim). Please allow a moment for the star to settle down after each button press.

Step 3

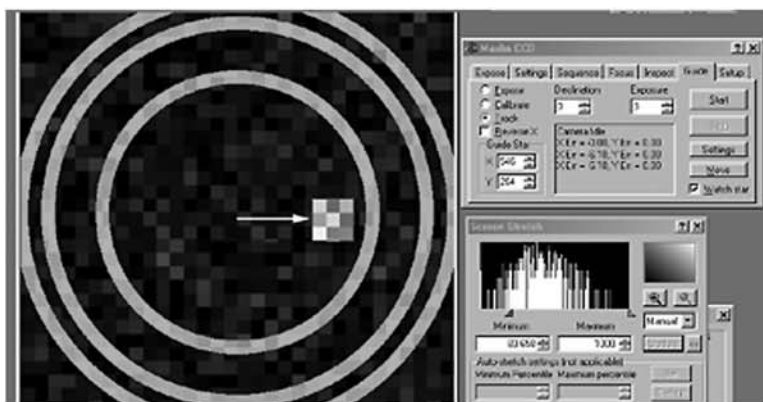

Press the South keypad button until the star has moved 6 pixels off the center in the opposite direction. Repeat Step 2 and note exactly the motion of the guide star as you move it with the pulsed motion at 0.5x.

You may wish to enable Track Log to record the numbers for further study. Please note on the log what you did at what time so the results will be useful later.

You have now characterized the Dec axis.

09-15-03

Astro-Physics Mach1GTO Re-Meshing the Worm Gear and Wheel

The revolutionary design of the Mach1GTO motor / gearbox makes re-meshing the worm gear into the worm wheel a simple process. The instructions apply equally to either axis.

1. On the face of the motor / gearbox that has the cable connection are two 1/4-20x5/16 Button Head Cap Screws. These are by far the two largest screw heads on that surface, and will be located on either side at the bottom of the box. (See the photo at right.) These screws are merely place holders to fill the holes that give access to the mounting bolts underneath. They do not hold anything. Simply remove them using a 5/32" Allen (hex) wrench and set them aside.

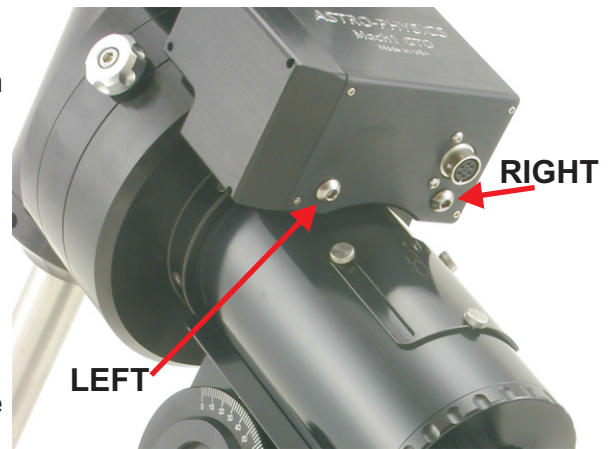

**1/4-20x5/16" Button Head
Use 5/32" Allen Wrench**

2. Insert the long end of the same 5/32" Allen wrench into the RIGHT hole (under the cable connection) and engage the socket of the attachment shoulder bolt that is inside. The bolt and the hole are lined up, so only minimal "fishing around" should be required. Loosen this bolt between 1/4 and 1/2 turn. DO NOT loosen any further or remove the bolt!

3. Repeat step 2 with the LEFT hole. As you loosen the second bolt you will feel the motor / gearbox come loose on the axis.

4. Gently rock the motor / gearbox from side to side and from front to back to be sure that the worm is fully seated in the wheel.

5. Tighten the LEFT shoulder bolt first. *It is critical for proper worm mesh to tighten the LEFT bolt first.* Tighten the bolt in small increments. As you tighten, wiggle the box slightly so that it finds its center as the bolt is gradually tightened. Once the bolt has made full contact, tighten about another 1/8 turn.

6. When the LEFT bolt is tight, tighten up the RIGHT bolt, also about 1/8 turn past the point of full contact. When you have the RIGHT bolt properly tightened, check the LEFT bolt to be sure that it still feels tight.

7. Once the attachment bolts are both tight, replace the two button head screws to close the access holes back up, and the re-meshing is complete.

NOTE: These are not lug nuts that hold the wheel onto your car. If you are unsure how tight to make the attachment bolts, I would suggest that you err on the side of caution and don't risk over tightening. It is easier to do this whole process over making everything a bit tighter the second time around than it is to undue the damage from too heavy a hand on the wrench. We have found that a good practice is to have the long end of the wrench in the hole, so that you only have the short end for leverage. Make it as tight as you can with this short lever, and then reverse the wrench and tweak the tightness by no more than 10 additional degrees.

Astro-Physics Mounting Plate Fastener Chart

A-P Part #	Description	Ships with:
FP1500	15" Flat Plate	(4) 1/4-20x5/8" SHCS [for mounting to 400, 900 or Mach1GTO] (4) M6-1.0x20mm SHCS [for mounting to 600E] (4) 1/4-20x3/4" SHCS [for mounting to 1200]
FP1800	18" Flat Plate	(6) 1/4-20x1" FHSCS [for mounting to 900 or 1200] (4) 1/4-20x1-1/4" FHSCS [Mach1GTO]
DOVE08	8" Dovetail Plate	(4) 1/4-20x1/2" SHCS [for mounting to 400] (4) M6-1.0x16mm FHSCS [for mounting to 600E] (4) 1/4-20x5/8" SHCS [for mounting to 900 or Mach1GTO, requires Q4047] (4) 10/32x3/4" SHCS [for mounting as Accessory Plate onto A-P rings]
DOVE 15	15" Dovetail Plate	(4) 1/4-20x1/2" FHSCS [for mounting to 400 or Mach1GTO] (4) M6-1.0x16mm FHSCS [for mounting to 600E] (4) 1/4-20x5/8" FHSCS [for mounting to 900 or 1200] (4) 10/32x3/4" SHCS [for mounting as Accessory Plate onto A-P rings]
DOVELM2	8.5" Dovetail Plate for Losmandy D Series Plate	(4) 1/4-20x5/8" SHCS [for mounting to 400 or Mach1GTO] (4) M6-1.0x20mm SHCS [for mounting 600E] (2) 1/4-20x5/8" FHSCS [for mounting to 1200] ** (4) 1/4-20x3/4" SHCS [for mounting to 900 or 1200] **
DOVELM16/S	16" Dovetail Plate for Losmandy D Series Plate for 1200GTO - "S" version for 900 or Mach1GTO	(6) 1/4-20x1" SHCS [for mounting to 900 or 1200] (4) 1/4-20x7/8" SHCS [for Mach1GTO]
DOVELM162	16" Dovetail Plate for Losmandy D Series Plate for 900, 1200, Mach1GTO. Also for 3600GTO w/ SB3622	(6) 1/4-20x1" SHCS [for mounting to 900, 1200 or Mach1GTO (uses 4)] (1) 1/4-20x3/4" FHSCS [opt. 900 or 1200 for end positions] (4) 1/4-20x3/4" SHCS [for SB3622 in side-by-side configuration]
900RP	15" Ribbed Plate for 900 or Mach1GTO	(6) 1/4-20x1" FHSCS [for mounting to 900] (4) 1/4-20x1-1/4" FHSCS [for mounting Mach1GTO]
1200RP15	15" Ribbed Plate for 1200	(6) 1/4-20x3/4" SHCS [for mounting to 1200]
1200RP	24" Ribbed Plate for 1200	(6) 1/4-20x1" SHCS [for mounting to 1200]
Q4047	900/Mach1GTO Adapter for use with DOVE08	(6) 1/4-20x5/8" FHSCS [for mounting to 900] (4) 1/4-20x1" FHSCS [for mounting to Mach1GTO]
SB0800 OR SB1000 OR SB1500	Sliding Bar	(2) 1/4-20X1/2" SHCS (2) Acorn Nuts (2) 1/4-20 Nuts (2) 1/4-20x3/8" SHCS (1) 10-32x5/8" FHSCS (1) 10-32 Nut
SBD12	12" Sliding Bar for the Losmandy D-Series Plates	(4) 1/4-20x1" low profile SHCS [for attaching the LMAPBLOCKS] (4) 1/4-20x1-1/4" FHCS [for attaching directly to 47RING] (4) 1/4-20x1/2" low profile SHCS (3) 1/4-20x3/8" SHCS (2) 1/4-20x7/8" SHCS
LT2APM	Losmandy Tripod to Astro-Physics Mount Adapter Plate	(3) 5/16-18x5/8" SHCS (4) 1/4-20x5/8" SHCS (4) 1/4-20x1" SHCS (3) 3/8-16x3/4 SHCS
CBAPT, TRAYSB & TRAYSB1	Control Box Adapter, Bi-Level Support Bar & Single Level Support Bar	(1) 1/4-20X3/4" FHSCS (1) 1/4-20X1" FHSCS (1) 5/16-18X1" BHSCS (2) 5/16-18X3/4" BHSCS
DOVE3622	22" Dovetail Saddle Plate for 3600GTO	(6) 3/8-16x1" SHCS (4) 3/8-16x1-1/2" SHCS
SB3622	Dovetail Sliding Bar for DOVE3622	(2) 3/8-16x1/2" low profile SHCS (4) 1/4-20x1" SHCS



** DOVELM2 may also be attached to 900 mount with (1) 1/4-20x5/8" FHSCS and (1) 1/4-20x3/4 SHCS